

MOTORPARTS

YOUR QUALITY SUPPLIER



MOTORPARTS

CATALOGO
GENERALE
2021

TOP[®]
- performances -

TPR
FACTORY





EDIZIONE GENNAIO 2021

Immagini, dati e indicazioni tecniche contenute in questo catalogo non sono impegnative.
Motorparts si riserva di apportare, per aggiornamenti o migliorie, qualsiasi tipo di variazione anche senza preavviso.

Motorparts consiglia di consultare il sito motorparts.it per avere informazioni sempre aggiornate e complete.

Your Performance & Quality Supplier!



MOTORPARTS

YOUR QUALITY SUPPLIER

ANNIVERSARIO
25
 WORLD RECORD
 1 Mile / 159,382 km/h

Motociclismo, novembre 1996

Sport / Record di velocità
 di Alessandro Perelli

236 Utilizzando un motore da scooter, il "Lulu Dragster" realizzato dalla Top Performances ha battuto due record di velocità sulla distanza del miglio per la classe 80 cc. Cronaca di una giornata storica sulla pista di Nardò vedendo sbriciolare a oltre 160 km/h un microbolide da 24 cv, pesante solamente 49 kg

● Battere un record, cercare di oltrepassare i limiti acquisiti, è da sempre un'esperienza ricca di fascino e carica di aspettative anche per il mondo dei motori. Una sfida affascinante che ha spinto anche la Top Performances, conosciuta anche in Italia, a intraprendere una avventura allentata nella produzione di kit di trasformazione per scooter, nata grazie alla par-

Missione

TECNOLOGIA DA RECORD

Il 30 ottobre Davide Govoni, giovane laureato del reparto Ricerca e Sviluppo della Top Performances, ha battuto, sulla pista di Nardò due record mondiali di velocità nella classe 80cc, toccando la velocità media di 139,511 km/h in 42"745, e un 159,382 km/h in 36"352. Il mezzo utilizzato è un prototipo progettato e realizzato dalla Top Performances con la collaborazione di Engine Engineering per le carinzioni di Vertice per il telaio. Il motore è un due tempi 80cc di derivazione scooter, raffreddato a liquido con frizione a motore. Interessante il fatto che buona parte delle componenti utilizzate per la realizzazione del propulsore siano parti specifiche normalmente commercializzate dalla Top Performances per gli scooter da competizione.

Aggiudicarsi due record mondiali di velocità è un grosso risultato per un'azienda impegnata nella progettazione e realizzazione di parti speciali destinate a scooter e ciclomotori da competizione. I record battuti dalla Top Performances sulla pista di Nardò ricoprono inoltre un particolare interesse, legato alla tipologia del motore adottato. Nei tentativi di record precedenti erano sempre stati utilizzati dei motori con trasmissione meccaniche, cambio a frizione comandata. La Top Performances ha invece utilizzato un motore da scooter 80cc, dotato cioè di trasmissione a cinghia, variatore di rapporto e frizione completamente automatiche. Un tipo di trasmissione che, rispetto ai motori con cambio a frizione comandata, comporta una penalizzazione delle prestazioni. Una sfida ulteriore che i tecnici della Top Performances sono riusciti a vincere realizzando comunque un motore capace di velocità e affidabilità superiori ai precedenti plurimarca. Due record quindi del tutto particolari. L'utilizzo di un motore da scooter ha consentito inoltre alla Top Performances l'utilizzo di molte delle componenti normalmente commercializzate. Questo dimostra che in campo agonistico l'azienda bolognese rapida nella progettazione e nella tecnica costruttiva. Pneumatici, propulsore, variatore, kit di aspirazione, molle dei ceppi frizione, questi alcuni esempi di prodotti utilizzati sul prototipo di Nardò e facilmente reperibili in commercio da chi si vuole cimentare sui campi di gara con il proprio scooter. Battere record mondiali è quindi un test severissimo, e la migliore dimostrazione di affidabilità e sicurezza dei prodotti Top Performances.

Tutti i prodotti Top Performances sono costruiti per uso esclusivamente agonistico. Ne è quindi vietato l'uso su strada pubblica.

Per ulteriori informazioni: Motorparts - Via F.lli Rosselli, 9 - 40012 Lippo di Calderara di Reno - Bologna

TOP®

- performances -

da 25 anni Imbattuti

Il 6 ottobre 1996, sulla pista per alte velocità di Nardò (LE), uno scooter realizzato dalla Top Performances e motorizzato Minarelli stabilì **2 nuovi primati mondiali** di velocità per la classe 80cc.

Pilota: Davide Govoni, all'epoca tecnico del reparto esperienze, e oggi responsabile R&D della Top Performances.

Mezzo: LOLU DRAGSTER, con telaio in lega di alluminio e motore scooter equipaggiato con parti speciali Top Performances.

1 miglio con partenza da fermo percorso in 42"754 alla media di 135,511 km/h

1 miglio con partenza lanciata percorso in 36"352 alla media di 159,382 km/h

Motociclismo, n. 44 1996

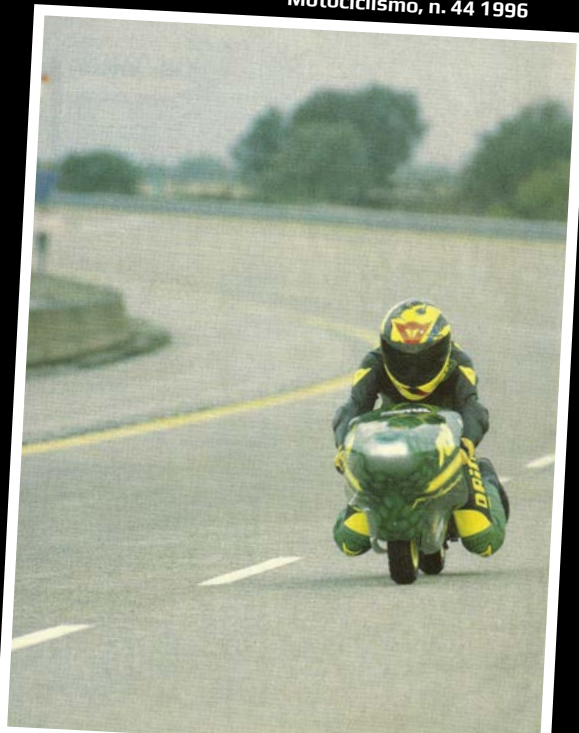

ScooterMagazine, novembre 1996

Ultra-Speed

Due record di velocità frantumati dal Lolu Dragster, autentico missile equipaggiato con un motore da scooter da 80 cc, messo a punto dai tecnici Top Performances.

Testo e foto di Andrea Leggieri



Conoscere un record mondiale è un'impresa. Invidio, anche nell'era della competizione globale. Al sole piovano, l'immaginazione della nuova religione tecnologica, le debite manovre di Atene, una vita dedicata a svezze motori, con una particolare applicazione per quelli monocilindrici a due tempi, e il polino di realizzazione con una di queste parti

meccaniche qualcosa di veramente memorabile. È lui il padre del "Lolu Dragster", il nome, poiché il nome Lolu nasconde le iniziali di Lorenzo e Luca, i nipoti di Atene. Ma il più "debut" di tutto lo comincia la vita emiliana al record. La via emiliana al record passa comunque dal via all'ago e numerose tavolate a fare gli onori di casa a Atene, una vita dedicata a svezze motori, con una particolare applicazione per quelli monocilindrici a due tempi, e il polino di realizzazione con una di queste parti

di buon augurio dopo l'altro. Davide domini non riesce neppure a entrare nella sua tuta speciale. Due il sogno, gente allegria, del "Lolu".

I Record

I record di cui si va di troppi sono i due sulla distanza di un miglio, con partenza da fermo e con partenza lanciata: per motociclisti con cilindrate fino a 80 cc. Sono dettati dal 1982 da un inglese, tal Garwood, con i tempi rispettivamente di 49"019 alla media di

SCOOTER MAGAZINE 81

**MERCHANDISING** pag 14**MPH HELMETS** pag 16**APPLICABILITÀ**

MOTO 50 cc	pag	26
SCOOTER 50 cc	pag	56
SCOOTER 50 cc RACING	pag	128
MAXI SCOOTER	pag	182
MOTO 125 cc	pag	290
ATV QUAD	pag	298
DR CLASSIC	pag	302
ELECTRIC PARTS	pag	312
MICROCAR	pag	372
GUARNIZIONI ATHENA ATV-UTV	pag	390
BATTERIE MOTO / ATV / UTV / MARINE	pag	400
FILTRI HIFLO ATV / UTV	pag	466
FILTRI HIFLO MARINE	pag	484
ELECTRIC PARTS ATV / UTV	pag	490
ELECTRIC PARTS PERSONAL WATERCRAFT	pag	582
ELECTRIC PARTS SNOWMOBILE	pag	592
DISCHI FRENO TRW / ATV / UTV	pag	614
PASTIGLIE FRENO TRW / ATV / UTV	pag	618

TPR FACTORY

CARTER RACING	pag	634
COPERCHIO FRIZIONE RACING	pag	640
FILTRI ARIA RACING	pag	642
GRUPPO TERMICO RACING	pag	644
ALBERO MOTORE RACING	pag	645
KIT FRIZIONE RACING	pag	646
PINZA FRENO RADIALE RACING	pag	647

TOP PERFORMANCES

ACCENSIONI	pag	650
ALBERI A CAMME	pag	653
ALBERI MOTORE	pag	654
CAMBIO COMPLETO	pag	653
CAMPANE FRIZIONI	pag	656
CARICA BATTERIE	pag	657
CARICATORI USB	pag	657
CINGHIE DI TRASMISSIONE TOP	pag	658
CONTAGIRI	pag	657



CONVERTITORI DI COPPIA	pag	661
COPERCHI	pag	375
CUSCINETTI	pag	662
DESMODROMICO CAMBIO	pag	653
FRIZIONI	pag	663
GRUPPI TERMICI STANDARD	pag	670
GRUPPI TERMICI MAGGIORATI	pag	673
GRUPPI TERMICI MAXI SCOOTER	pag	679
GRUPPI TERMICI RACING	pag	683
KIT ASPIRAZIONE	pag	689
KIT DI PROGRAMMAZIONE	pag	657
MASSE VARIATORE	pag	696
MOLLE CONTRASTO VARIATORE	pag	700
MOLLE FRIZIONE	pag	704
PIGNONI	pag	705
INGRANAGGI	pag	705
RASAMENTI	pag	706
RAPPORTI	pag	707
REGOLATORE DI PRESSIONE	pag	707
SCARICHI COMPLETI	pag	708
SCARICHI GP	pag	708
SCARICHI NARDÒ 2	pag	709
VALVOLE LAMELLARI	pag	710
VARIATORI	pag	713

SPARE PARTS

ACCENSIONI	pag	724
ALBERI MOTORE	pag	726
ALTERNATORI	pag	736
AM6 RICAMBI MOTORE	pag	737
BATTERIE	pag	744
BIELLE	pag	745
BLOCCHI ACCENSIONE	pag	746
BOBINE	pag	747
CAMPANE FRIZIONE	pag	755
CARBURATORI	pag	760
CENTRALINE	pag	762
CINGHIE DI TRASMISSIONE	pag	763
COLLETTORI	pag	781
CONVOGLIATORI	pag	785
CUSCINETTI	pag	785
CUSCINETTI NTN	pag	792
CUSCINETTI SKF	pag	788

SPARE PARTS

INDICE GENERALE

**SPARE
PARTS**

FILTRI ARIA	pag	799
FILTRI OLIO	pag	806
FRIZIONI	pag	813
GUARNIZIONI SMERIGLIO	pag	820
GUARNIZIONI MOTORE	pag	824
KIT REVISIONE POMPA ACQUA	pag	828
KIT TAGLIANDO	pag	836
KIT TRASMISSIONE	pag	840
LAMPADE OSRAM	pag	844
LAMPADE TOPLIGHT	pag	845
MEMBRANE CARBURATORE	pag	852
MOLLE A GAS - SELLA	pag	855
MOTORINI AVVIAMENTO	pag	856
PARAOLI	pag	909
POMPE BENZINA	pag	910
PULEGGE VARIATORI	pag	912
REGOLATORI	pag	918
RUOTE LIBERE	pag	956
SCOOTER 50 RICAMBI MOTORE	pag	966
ALBERI ENTRATA MOTO	pag	967
ALBERI MESSA IN MOTO	pag	966
ALBERI USCITA MOTO	pag	966
GABBIA	pag	968
GRUPPI INGRANAGGI SECONDARI	pag	969
INGRANAGGI AVVIAMENTO	pag	968
INTERMITTENZE	pag	969
MOLLE	pag	968
SCODELLINO	pag	968
SEGMENTI MAXI SCOOTER	pag	970
SERIE PARAOLI	pag	906
STATORI	pag	971
TUBI BENZINA	pag	977
VALVOLE LAMELLARI	pag	978

DR CLASSIC

CILINDRETTI FRENO	pag	982
FRIZIONI	pag	983
GANASCE FRENO	pag	984
GRUPPI TERMICI	pag	987
GRUPPI TERMICI HIGH PERFORMANCE	pag	986
GUARNIZIONI ASPIRAZIONE	pag	1002
GUARNIZIONI BASE CILINDRO	pag	1002
GUARNIZIONI SCARICO	pag	1002
SCARICHI PROMA	pag	1003





SEGMENTI	pag	1005
SERIE GUARNIZIONI	pag	1000

SACHS

COPERCHI SCATOLA FRIZIONE	pag	1008
DISCHI FRIZIONE	pag	1010
KIT FRIZIONE	pag	1012
MOLLE A DIAFRAMMA	pag	1013
SPINGIDISCHI	pag	1014



RECKLESS

CONTRAPPESI MANUBRIO	pag	1018
COVER FORO SPECCHI	pag	1018
LEVA FRENO A MANO	pag	1019
PEDALINE PASSEGGERO	pag	1019
PROTEZIONE LEVA FRENO	pag	1020
TAPPO FLUIDO FRENI	pag	1020
TAPPO OLIO MOTORE	pag	1021



XFORTE

LINEA BICI	pag	1028
LINEA CUSTOM	pag	1027
LINEA MOTO	pag	1024



MICROCAR

AMMORTIZZATORI	pag	1032
CANDELETTE	pag	1044
CILINDRETTI FRENO	pag	1045
CINGHIE	pag	1045
CUSCINETTI	pag	1045
DISCHI FRENO	pag	1046
DISTRIBUZIONE	pag	1048
FILTRI ARIA	pag	1050
FILTRI CARBURANTE	pag	1052
FILTRI GASOLIO	pag	1052
FILTRI OLIO	pag	1054
KIT GIUNTI	pag	1056
PASTIGLIE FRENO	pag	1057
PINZE FRENO	pag	1060
POMPE ACQUA	pag	1062
POMPE GASOLIO	pag	1064
SENSORI / ELETTROSTOP	pag	1065
SEMIASSI	pag	1066
TESTE DI STERZO	pag	1068

MOTORPARTS

YOUR QUALITY SUPPLIER



Motorparts in pista!

TPR Factory, nasce nel 2019 e ad Elcma dello stesso anno
presenta il Carter Racing da competizione

Il Carter più evoluto del mercato

Oggi TPR Factory conferma il "Progetto Racing" con una gamma
esclusiva di prodotti ad altissime prestazioni

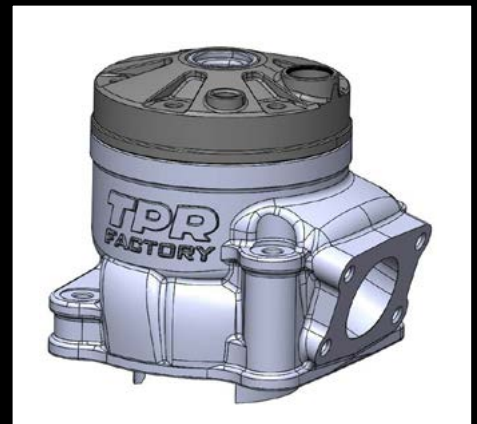

MOTORPARTS

YOUR QUALITY SUPPLIER



MOTO

ATV / UTV

PERSONAL WATERCRAFT

DISTRIBUTORE UFFICIALE



SCOOTER

SNOWMOBILE

VESPA

MICROCAR



MOTORPARTS

YOUR QUALITY SUPPLIER

TPR FACTORY



CAPELLINO

Colore: NERO

CODICE

99ME003



Cartella 18 Adesivi Assortiti

Dimensioni 21x29,7 cm

CODICE

99AD001



LANYARD

CODICE

99ME004



SUPPORTO USB

CODICE

99ME005

Merchandising



▲ POLO BICOLORE Tpr Factory

75% COTONE - 25% ELASTAN
180 GR.

Colore: GRIGIO / NERO / ROSSO

COD. TAGLIE

S	99ME007S
M	99ME007M
L	99ME007L
XL	99ME007XL
XXL	99ME007XXL
XXXL	99ME007XXXL

▲
92% POLIESTERE - 8% ELASTAN
180 GR.

Colore: NERO / GRIGIO / ROSSO

COD. TAGLIE

S	99ME008S
M	99ME008M
L	99ME008L
XL	99ME008XL
XXL	99ME008XXL
XXXL	99ME008XXXL



▲ CAMICIA Stretch M/Lunga

75% COTONE - 25% ELASTAN
130 GR.

Colore: BIANCO - NERO

COD. TAGLIE

	NERO	BIANCO
S	99ME002S	99ME102S
M	99ME002M	99ME102M
L	99ME002L	99ME102L
XL	99ME002XL	99ME102XL

▲ GIACCA

92% POLIESTERE - 8% ELASTAN
340 GR.

Colore: NERO

COD. TAGLIE

S	99ME001S
M	99ME001M
L	99ME001L
XL	99ME001XL

▲ T-SHIRT Tpr Factory

Colore: NERO

COD. TAGLIE

S	99ME006S
M	99ME006M
L	99ME006L
XL	99ME006XL
XXL	99ME006XXL
XXXL	99ME006XXXL

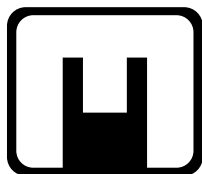

MOTORPARTS è da sempre garanzia di affidabilità e innovazione nella progettazione di parti speciali, ricambi e accessori per le due ruote.

Oggi la **MOTORPARTS** compie un ulteriore passo in avanti nella propria evoluzione creando il **Marchio MPH "MotorPartsHelmets"** con un contenuto di tecnologia ed **innovazione** di alto livello, realizzato dal **Team R&D** e da **Professionisti del Settore**, conservando lo stile e l'immagine dell'Azienda.

Una gamma di Caschi focalizzata sulla **Sicurezza e Praticità** di utilizzo quotidiana, coniugati ad alta **tecnologia e funzionalità**.

Uno sguardo verso il **Futuro** con le basi solide nella Storia del Brand.

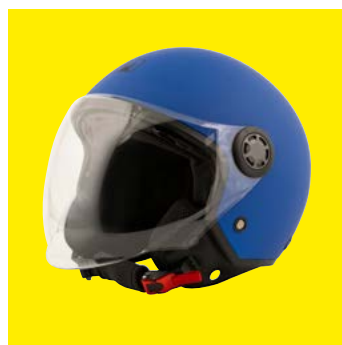





RAPTOR MODULARE CON 2 VISIERE - P/J

MODULARE in Calotta esterna e mentoniera stampate con materiale Termoplastico in taglie uniche.

Peso Casco: 1580 gr. +/-50 gr.

Taglie: dalla XS alla XXL.

Omologato P/J - ECE 22.05

Calotta interna EPS (polistirolo) in due misure, stampata a doppia densità, ad alto assorbimento d'urto.

EPS M copre tg. XS/S/M

EPS L copre tg. L/XL/XXL

Visiera esterna trasparente con grande campo visivo, stampata in policarbonato, omologata classe "A", e con trattamento antigraffio, con sgancio rapido per la rimozione, predisposta per Lente Pinlock '70.

Visiera interna parasole a scomparsa, movimento indipendente, stampata in policarbonato, trattata antigraffio, fumè al 60%, con sgancio rapido per la rimozione.

Interno in tessuto microfibra, ipoallergenico, completamente removibile e lavabile.

Predisposizione Bluetooth con sede per gli auricolari. Cinturino con chiusura micrometrica.

Anello in metallo per aggancio al veicolo.

Ventilazione Clima System: due frontali regolabili per l'ingresso aria, un estrattore posteriore regolabile per il mantenimento della temperatura interna grazie alla canalizzazione interna

EPS ed una ventilazione frontale mentoniera per il sistema anti-appannamento visiera.



COLORE	TAGLIA	CODICE
MATT BLACK	XS	HLMD101XS
	S	HLMD101S
	M	HLMD101M
	L	HLMD101L
	XL	HLMD101XL
GLOSS WHITE	XXL	HLMD101XXL
	XS	HLMD104XS
	S	HLMD104S
	M	HLMD104M
	L	HLMD104L
GLOSS GREY	XL	HLMD104XL
	XXL	HLMD104XXL
	XS	HLMD107XS
	S	HLMD107S
	M	HLMD107M
MATT BLACK YELLOW HV	L	HLMD107L
	XL	HLMD107XL
	XXL	HLMD107XXL
	XS	HLMD110XS
	S	HLMD110S
BLACK TITANIUM YELLOW	M	HLMD110M
	L	HLMD110L
	XL	HLMD110XL
	XXL	HLMD110XXL
	XS	HLMD115XS
	S	HLMD115S
	M	HLMD115M
	L	HLMD115L
	XL	HLMD115XL
	XXL	HLMD115XXL

ONE LITE JET VISIERA SINGOLA

JET in Calotta esterna stampata con materiale Termoplastico in taglia unica.

Peso Casco: 1200 gr. +/-50 gr.

Taglie: dalla XS alla XXL.

Omologato ECE 22.05.

Calotta interna EPS (polistirolo) in due misure, stampata a doppia densità, ad alto assorbimento d'urto.

EPS M copre tg. XS/S/M

EPS L copre tg. L/XL/XXL

Visiera esterna trasparente ad occhiale, stampata in policarbonato, omologata classe "A", e con trattamento antigraffio, removibile con chiave in dotazione.

Interno in tessuto microfibra, ipoallergenico, completamente removibile e lavabile.

Cinturino con chiusura micrometrica e passante in microfibra sul cinturino per aumentare il comfort con cinturino allacciato.

Anello in metallo per aggancio al veicolo.



COLORE	TAGLIA	CODICE
MATT BLACK	XS	HLDJ201XS
	S	HLDJ201S
	M	HLDJ201M
	L	HLDJ201L
	XL	HLDJ201XL
MATT GREY BELFAST	XXL	HLDJ201XXL
	XS	HLDJ203XS
	S	HLDJ203S
	M	HLDJ203M
	L	HLDJ203L
GLOSS WHITE	XL	HLDJ203XL
	XXL	HLDJ203XXL
	XS	HLDJ204XS
	S	HLDJ204S
	M	HLDJ204M
MATT FLUO YELLOW	L	HLDJ204L
	XL	HLDJ204XL
	XXL	HLDJ204XXL
	XS	HLDJ206XS
	S	HLDJ206S
MATT FUCSIA	M	HLDJ206M
	L	HLDJ206L
	XL	HLDJ206XL
	XXL	HLDJ206XXL
	XS	HLDJ209XS
MATT BLUE	S	HLDJ209S
	M	HLDJ209M
	L	HLDJ209L
	XL	HLDJ209XL
	XXL	HLDJ209XXL
MATT FLUO ORANGE	XS	HLDJ205XS
	S	HLDJ205S
	M	HLDJ205M
	L	HLDJ205L
	XL	HLDJ205XL
	XXL	HLDJ205XXL
	XS	HLDJ208XS
	S	HLDJ208S
	M	HLDJ208M
	L	HLDJ208L
	XL	HLDJ208XL
	XXL	HLDJ208XXL



ONE

JET CON 2 VISIERE FRONTINO INCLUSO

JET in Calotta esterna stampata con materiale Termoplastico in taglia unica.

Peso: 1250 gr. +/-50 gr. Taglie: dalla XS alla XXL.

Omologato ECE 22.05.

Calotta interna EPS (polistirolo) in due misure, stampata a doppia densità, ad alto assorbimento d'urto.

EPS M copre tg. XS/S/M

EPS L copre tg. L/XL/XXL

Visiera esterna trasparente, lunga e con grande campo visivo, stampata in policarbonato, omologata classe "A", e con trattamento antigraffio, removibile con chiave in dotazione.

Visiera interna parasole a scomparsa, movimento indipendente, stampata in policarbonato, trattata antigraffio, fumè al 60%, con sgancio rapido per la rimozione.

Interno in tessuto microfibra, ipoallergenico, completamente removibile e lavabile.

Cinturino con chiusura micrometrica e passante in microfibra sul cinturino per aumentare il comfort con cinturino allacciato.

Anello in metallo per aggancio al veicolo.

Frontino in plastica Nero opaco incluso, da sostituire alla visiera esterna. Abbinato alla visiera parasole a scomparsa crea una seconda versione del casco.



COLORE	TAGLIA	CODICE
MATT BLACK	XS	HLDJ101XS
	S	HLDJ101S
	M	HLDJ101M
	L	HLDJ101L
	XL	HLDJ101XL
	XXL	HLDJ101XXL
MATT GREEN	XS	HLDJ102XS
	S	HLDJ102S
	M	HLDJ102M
	L	HLDJ102L
	XL	HLDJ102XL
	XXL	HLDJ102XXL
MATT GREY BELFAST	XS	HLDJ103XS
	S	HLDJ103S
	M	HLDJ103M
	L	HLDJ103L
	XL	HLDJ103XL
	XXL	HLDJ103XXL
GLOSS WHITE	XS	HLDJ104XS
	S	HLDJ104S
	M	HLDJ104M
	L	HLDJ104L
	XL	HLDJ104XL
	XXL	HLDJ104XXL
MATT FLUO YELLOW	XS	HLDJ106XS
	S	HLDJ106S
	M	HLDJ106M
	L	HLDJ106L
	XL	HLDJ106XL
	XXL	HLDJ106XXL
MATT FUCSIA	XS	HLDJ109XS
	S	HLDJ109S
	M	HLDJ109M
	L	HLDJ109L
	XL	HLDJ109XL
	XXL	HLDJ109XXL
MATT BLUE	XS	HLDJ105XS
	S	HLDJ105S
	M	HLDJ105M
	L	HLDJ105L
	XL	HLDJ105XL
	XXL	HLDJ105XXL



ONE AIR JET VISIERA SINGOLA CON SISTEMA VENTILAZIONE CLYMA SYSTEM

JET in Calotta esterna stampata con materiale Termoplastico in taglia unica.

Peso Casco: 1120 gr. +/-50 gr.

Taglie: dalla XS alla XXL.

Omologato ECE 22.05.

Calotta interna EPS (polistirolo) in due misure, stampata a doppia densità, ad alto assorbimento d'urto.

EPS M copre tg. XS/S/M

EPS L copre tg. L/XL/XXL

Visiera esterna trasparente, lunga e con grande campo visivo, stampata in policarbonato, omologata classe "A", e con trattamento antigraffio.

Interno in tessuto microfibra, ipoallergenico, completamente removibile e lavabile.

Cinturino con chiusura micrometrica e passante in microfibra sul cinturino per aumentare il comfort con cinturino allacciato.

Anello in metallo per aggancio al veicolo.

Ventilazione Clima System a 3 prese d'aria: due frontali regolabili per l'ingresso aria e un estrattore posteriore per il mantenimento della temperatura interna grazie alla canalizzazione interna EPS.



COLORE	TAGLIA	CODICE
MATT BLACK	XS	HLDJ301XS
	S	HLDJ301S
	M	HLDJ301M
	L	HLDJ301L
	XL	HLDJ301XL
	XXL	HLDJ301XXL
GLOSS WHITE	XS	HLDJ304XS
	S	HLDJ304S
	M	HLDJ304M
	L	HLDJ304L
	XL	HLDJ304XL
	XXL	HLDJ304XXL
MATT BLUE	XS	HLDJ305XS
	S	HLDJ305S
	M	HLDJ305M
	L	HLDJ305L
	XL	HLDJ305XL
	XXL	HLDJ305XXL
GLOSS GREY	XS	HLDJ307XS
	S	HLDJ307S
	M	HLDJ307M
	L	HLDJ307L
	XL	HLDJ307XL
	XXL	HLDJ307XXL





DJ JET CON 2 VISIERE CON SISTEMA VENTILAZIONE CLIMA SYSTEM

JET in Calotta esterna stampata con materiale Termoplastico in taglia unica.

Peso Casco: 1250 gr. +/-50 gr.

Taglie: dalla XS alla XXL.

Omologato ECE 22.05.

Calotta interna EPS (polistirolo) in due misure, stampata a doppia densità, ad alto assorbimento d'urto.

EPS M copre tg. XS/S/M

EPS L copre tg. L/XL/XXL

Visiera esterna trasparente, lunga e con grande campo visivo, stampata in policarbonato, omologata classe "A", e con trattamento antigraffio.

Visiera interna parasole a scomparsa, movimento indipendente, stampata in policarbonato, trattata antigraffio, fumè al 60%, con sgancio rapido per la rimozione.

Interno in tessuto microfibra, ipoallergenico, completamente removibile e lavabile.

Ventilazione Clima System a 2 prese d'aria: una frontale regolabile per l'ingresso aria e un estrattore posteriore per il mantenimento della temperatura interna grazie alla canalizzazione interna EPS.

Cinturino con chiusura micrometrica e passante in microfibra sul cinturino per aumentare il comfort con cinturino allacciato.

Anello in metallo per aggancio al veicolo.



COLORE	TAGLIA	CODICE
MATT BLACK	XS	HLJT101XS
	S	HLJT101S
	M	HLJT101M
	L	HLJT101L
	XL	HLJT101XL
GLOSS WHITE	XXL	HLJT101XXL
	XS	HLJT104XS
	S	HLJT104S
	M	HLJT104M
	L	HLJT104L
MATT GREY BELFAST	XL	HLJT104XL
	XXL	HLJT104XXL
	XS	HLJT103XS
	S	HLJT103S
	M	HLJT103M
MATT BLUE	L	HLJT103L
	XL	HLJT103XL
	XXL	HLJT103XXL
	XS	HLJT105XS
	S	HLJT105S
WHITE RED/BLUE	M	HLJT105M
	L	HLJT105L
	XL	HLJT105XL
	XXL	HLJT105XXL
	XS	HLJT113XS
BLACK YELLOW GREY	S	HLJT113S
	M	HLJT113M
	L	HLJT113L
	XL	HLJT113XL
	XXL	HLJT113XXL
	XS	HLJT114XS
	S	HLJT114S
	M	HLJT114M
	L	HLJT114L
	XL	HLJT114XL
	XXL	HLJT114XXL

PLAY JET BAMBINO

JET in Calotta esterna stampata con materiale Termoplastico in taglia unica.

Peso Casco: 810 gr. +/-50 gr.

Taglie: SJ - MJ - LJ - XLJ

Omologato ECE 22.05.

Calotta interna EPS (polistirolo) in unica misura, stampata a doppia densità, ad alto assorbimento d'urto. EPS tg. Unica copre tg. SJ/MJ/LJ/XLJ

Visiera esterna trasparente, lunga e con grande campo visivo, stampata in policarbonato, omologata classe "A", e con trattamento antigraffio, removibile con chiave in dotazione.

Interno in tessuto microfibra, ipoallergenico, completamente removibile e lavabile.

Cinturino con chiusura micrometrica e passante in microfibra sul cinturino per aumentare il comfort con cinturino allacciato.

Anello in metallo per aggancio al veicolo.

Ventilazione Clima System con 2 prese d'aria frontali regolabili per l'ingresso aria per il mantenimento della temperatura interna grazie alla canalizzazione interna EPS.



COLORE	TAGLIA	CODICE
MATT FLUO YELLOW	SJ	HLCL106SJ
	MJ	HLCL106MJ
	LJ	HLCL106LJ
	XLJ	HLCL106XLJ
MATT FUCSIA	SJ	HLCL109SJ
	MJ	HLCL109MJ
	LJ	HLCL109LJ
	XLJ	HLCL109XLJ
MATT BLUE	SJ	HLCL105SJ
	MJ	HLCL105MJ
	LJ	HLCL105LJ
	XLJ	HLCL105XLJ
MATT FLUO ORANGE	SJ	HLCL108SJ
	MJ	HLCL108MJ
	LJ	HLCL108LJ
	XLJ	HLCL108XLJ
GLOSS WHITE	SJ	HLCL104SJ
	MJ	HLCL104MJ
	LJ	HLCL104LJ
MATT BLACK	XLJ	HLCL104XLJ
	SJ	HLCL101SJ
	MJ	HLCL101MJ
	LJ	HLCL101LJ
WHITE BULLDOG	XLJ	HLCL101XLJ
	SJ	HLCL112SJ
	MJ	HLCL112MJ
	LJ	HLCL112LJ
XLJ	HLCL112XLJ	



H-EASY JET CLASSIC FIBERGLASS

JET in Calotta esterna stampata in Fiberglass di ultima generazione, in 5 misure di calotta.

Peso Casco: 950 gr. +/-50 gr.

Taglie: dalla XS alla XXL.

Omologato ECE 22.05.

Calotta interna EPS (polistirolo) realizzata in 5 misure di calotta dedicate a ciascuna taglia, stampate a doppia densità, ad alto assorbimento d'urto.

Interno in tessuto microfibra scamosciato, abbinato ad una similpelle morbida, ipoallergenico, guance removibili.

Predisposizione Bluetooth con sede per gli auricolari. Cinturino con chiusura micrometrica.

Anello in metallo per aggancio al veicolo.

Frontino in plastica 3 Bottoni Nero opaco incluso.



COLORE	TAGLIA	CODICE
MATT BLACK	X5	HLFB101X5
	S	HLFB101S
	M	HLFB101M
	L	HLFB101L
	XL	HLFB101XL
	XXL	HLFB101XXL
GLOSS WHITE	X5	HLFB104X5
	S	HLFB104S
	M	HLFB104M
	L	HLFB104L
	XL	HLFB104XL
	XXL	HLFB104XXL
GRAPHIC CLASSIC	X5	HLFB111X5
	S	HLFB111S
	M	HLFB111M
	L	HLFB111L
	XL	HLFB111XL
	XXL	HLFB111XXL



RICAMBI

MODELLO	CODICE	RICAMBIO
---------	--------	----------

ONE	HLDJ1RV01	Visierino Interno Parasole
	HLDJ1RV02	Visiera Trasparente Antigraffio Occhiale
	HLDJ1RV03	Visiera Trasparente Antigraffio Lunga
	HLDJ1RV04	Frontino
	HLDJ1RKV01	Kit Meccanismo Visiera + Viti
	HLDJ1RTLXS	Kit Interno Removibile + Guance XS
	HLDJ1RTLS	Kit Interno Removibile + Guance S
	HLDJ1RTLTM	Kit Interno Removibile + Guance M
	HLDJ1RTLXL	Kit Interno Removibile + Guance L
	HLDJ1RTLXL	Kit Interno Removibile + Guance XL
	HLDJ1RTLXXL	Kit Interno Removibile + Guance XXL
HLBTH001	Kit Bluetooth City Connect con Guance	

ONE LITE	HLDJ1RV02	Visiera Trasparente Antigraffio Occhiale
	HLDJ1RV03	Visiera Trasparente Antigraffio Lunga
	HLDJ1RV04	Frontino
	HLDJ1RKV01	Kit Meccanismo Visiera + Viti
	HLDJ2RTLXS	Kit Interno Removibile + Guance XS
	HLDJ2RTLS	Kit Interno Removibile + Guance S
	HLDJ2RTLTM	Kit Interno Removibile + Guance M
	HLDJ2RTLXL	Kit Interno Removibile + Guance L
	HLDJ2RTLXL	Kit Interno Removibile + Guance XL
	HLDJ2RTLXXL	Kit Interno Removibile + Guance XXL
	HLBTH001	Kit Bluetooth City Connect con Guance

ONE	HLDJ1RV01	Visierino Interno Parasole
	HLDJ1RV02	Visiera Trasparente Antigraffio Occhiale
	HLDJ1RV03	Visiera Trasparente Antigraffio Lunga
	HLDJ1RV04	Frontino
	HLDJ1RKV01	Kit Meccanismo Visiera + Viti
	HLDJ1RTLXS	Kit Interno Removibile + Guance XS
	HLDJ1RTLS	Kit Interno Removibile + Guance S
	HLDJ1RTLTM	Kit Interno Removibile + Guance M
	HLDJ1RTLXL	Kit Interno Removibile + Guance L
	HLDJ1RTLXL	Kit Interno Removibile + Guance XL
	HLDJ1RTLXXL	Kit Interno Removibile + Guance XXL
HLBTH001	Kit Bluetooth City Connect con Guance	

ONE LITE	HLDJ1RV02	Visiera Trasparente Antigraffio Occhiale
	HLDJ1RV03	Visiera Trasparente Antigraffio Lunga
	HLDJ1RV04	Frontino
	HLDJ1RKV01	Kit Meccanismo Visiera + Viti
	HLDJ2RTLXS	Kit Interno Removibile + Guance XS
	HLDJ2RTLS	Kit Interno Removibile + Guance S
	HLDJ2RTLTM	Kit Interno Removibile + Guance M
	HLDJ2RTLXL	Kit Interno Removibile + Guance L
	HLDJ2RTLXL	Kit Interno Removibile + Guance XL
	HLDJ2RTLXXL	Kit Interno Removibile + Guance XXL
	HLBTH001	Kit Bluetooth City Connect con Guance

MODELLO	CODICE	RICAMBIO
---------	--------	----------

ONE AIR	HLDJ3RV03	Visiera Trasparente Antigraffio
	HLDJ3RKV01	Kit Meccanismo Visiera + Viti
	HLDJ3RVF01	Kit ventilazioni front.
	HLDJ3REAP1	Kit estrattore aria post.
	HLDJ3RTLXS	Kit Interno Removibile + Guance XS
	HLDJ3RTLS	Kit Interno Removibile + Guance S
	HLDJ3RTLTM	Kit Interno Removibile + Guance M
	HLDJ3RTLXL	Kit Interno Removibile + Guance L
	HLDJ3RTLXL	Kit Interno Removibile + Guance XL
	HLDJ3RTLXXL	Kit Interno Removibile + Guance XXL
	HLBTH001	Kit Bluetooth City Connect con Guance

PLAY	HLCL1RV03	Visiera Trasparente Antigraffio
	HLCL1RKV01	Kit Meccanismo Visiera + Viti
	HLCL1RTLSJ	Kit Interno Removibile + Guance SJ
	HLCL1RTLTMJ	Kit Interno Removibile + Guance MJ
	HLCL1RTLXL	Kit Interno Removibile + Guance LJ
	HLCL1RVF01	Kit ventilazioni front.

DJ	HLJT1RV03	Visiera Trasparente Antigraffio
	HLJT1RV01	Visierino Interno Parasole
	HLJT1RTLXS	Kit Interno Removibile + Guance XS
	HLJT1RTLS	Kit Interno Removibile + Guance S
	HLJT1RTLTM	Kit Interno Removibile + Guance M
	HLJT1RTLXL	Kit Interno Removibile + Guance L
	HLJT1RTLXL	Kit Interno Removibile + Guance XL
	HLJT1RTLXXL	Kit Interno Removibile + Guance XXL
	HLJT1RVF01	Kit ventilazioni front.
	HLJT1REAP1	Kit estrattore aria post.
	HLBTH001	Kit Bluetooth City Connect con Guance













RAPTOR	HLMD1RV03	Visiera Trasparente Antigraffio (predisposta Pinlock)
	HLMD1RV01	Visierino Interno Parasole
	HLMD1RKV01	Kit Meccanismo Visiera + Viti
	HLMD1RPV01	Kit Paravento
	HLMD1RTLXS	Kit Interno Removibile + Guance XS
	HLMD1RTLS	Kit Interno Removibile + Guance S
	HLMD1RTLTM	Kit Interno Removibile + Guance M
	HLMD1RTLXL	Kit Interno Removibile + Guance L
	HLMD1RTLXL	Kit Interno Removibile + Guance XL
	HLMD1RTLXXL	Kit Interno Removibile + Guance XXL
	HLMD1RVP1	Lente Pinlock Antifog '70
	HLMD1RVM01	Kit ventilazione mentoniera
	HLMD1RVF01	Kit ventilazioni front.
	HLMD1REAP1	Kit estrattore aria post.

H-EASY	HLFB1RV04	Frontino plastica nera 3 Bottoni
--------	-----------	----------------------------------



gamma prodotti

APRILIA	APRILIA	APRILIA	APRILIA
CLASSIC	EUROPA	EUROPA	MX
92-99	90-90	91-92	04-04
50cc 2T LC	50cc 2T LC	50cc 2T LC	50cc 2T LC
AM 6	RV4	AM 3-4-5	AM 6

IT	EN	FR				
ALBERO MOTORE standard	Standard Crankshaft	VILEBREQUIN standard		IM07017		IM07017
ALBERO MOTORE corsa 39 mm a piattelli pieni	Racing Crankshaft Stroke 39mm	VILEBREQUIN course 39 mm à contre-poids pleins		9921720		9921720
BIELLA Axe 16	CONROD Axle 16	BIELLE Axe 16		IM07033		IM07033
BIELLA Axe 18	CONROD Axle 18	BIELLE Axe 18		IM07036		IM07036
CAMBIO COMPLETO RACING	COMPLETE GEAR BOX RACING	BOÎTE DE VITESSES COMPLÈTE RACING		9935000		9935000
DESMODROMICO CAMBIO	SHIFT DRUM GEAR	BOÎTE DE VITESSES		9920020		9920020
CENTRALINA AD ANTICIPO FISSO	CDI UNIT WITH VARIABLE ADVANCE (Ducati 6 coils)	BOÎTE ÉLECTRONIQUE numérique à avance variable volant Ducati 6 pôles		9910150		9910150
CENTRALINE RACING	RACING EU4 CONTROL UNIT	BOÎTIER ÉLECTRONIQUE RACING EU4		9921690		9921690
COPERCHIO FRIZIONE RACING TRASPARENTE	TRANSPARENT CRANKCASE COVER	TRANSPARENT COVER EMBRAYAGE		99CFAMT10		99CFAMT10
COPERCHIO FRIZIONE RACING ALLUMINIO	ALUMINIUM CRANKCASE COVER	ALUMINIUM COVER EMBRAYAGE		99CFAMA10		99CFAMA10
COLLETTORE ASPIRAZIONE STANDARD	STANDARD INLET MANIFOLD	COLLECTEUR D'ADMISSION STANDARD		CT00746		CT00746
CUSCINETTI DI BANCO TPR Carbonitrurati Serie	BEARINGS TPR Carbonitrided	PALIERI DE VILEBREQUIN TPR Carbonitrurés Jeu		9929180		9929180
FRIZIONE a denti dritti	STRAIGHT TEETH CLUTCH	EMBRAYAGE À DENTS DROITES		9918550		9918550
GRUPPO TERMICO Ø STD Ghisa	CYLINDER KIT Ø Standard (CAST IRON)	CYLINDRE COMPLET Ø STD Fonte		9916770 KT00098		9916770 KT00098
GRUPPO TERMICO Ø Maggioreto Ghisa	CYLINDER KIT BIG BORE (CAST IRON)	CYLINDRE COMPLET Ø Majoré Fonte		9919250 KT00114		9919250 KT00114
GRUPPO TERMICO RACING Ø 49,5 Ghisa	CYLINDER KIT RACING Ø 49,5 (CAST IRON)	CYLINDRE COMPLET RACING Ø 49,5 Fonte		9919240		9919240
GRUPPO TERMICO RACING Ø 49,5 Ghisa testa scomposta	CYLINDER KIT RACING Ø 49,5 (CAST IRON) Decomposable head	CYLINDRE COMPLET RACING Ø 49,5 Fonte culasse décomposée		9921150		9921150
GRUPPO TERMICO RACING Ø 50 alluminio	CYLINDER KIT RACING Ø 50 (ALUMINIUM)	CYLINDRE COMPLET RACING Ø 50 aluminium		9924130		9924130
GRUPPO TERMICO RACING Ø Standard Alluminio	CYLINDER KIT RACING Ø Standard (ALUMINIUM)	CYLINDRE COMPLET RACING Ø Standard Aluminium		9934500		9934500
INGRANAGGIO 6 VELOCITA' 1ª serie	GEAR 6° SPEED AM6 1ª SERIES	ENGRENAGE 6 VITESSES 1ª SERIE		9919080		9919080
INGRANAGGIO 6 VELOCITA' 2ª serie	GEAR 6° SPEED AM6 2ª SERIES	ENGRENAGE 6 VITESSES 2ª SERIE		9931910		9931910
KIT ASPIRAZIONE COMPLETO TM 24	COMPLETE MIKUNI INLET KIT TM 24 TPR 360	KIT ASPIRATION COMPLET MIKUNI TM 24 TPR 360		9930910		9930910
KIT ASPIRAZIONE COMPLETO OKO 28	COMPLETE INLET KIT OKO 28 TPR 360	KIT ASPIRATION COMPLET OKO 28 TPR 360		9931750		9931750
KIT FRIZIONE RACING TPR FACTORY	TPR FACTORY RACING CLUTCH	KIT EMBRAYAGE RACING TPR FACTORY		99F5MAM10		99F5MAM10
KIT FRIZIONE + TAMBURO	HOUSING CLUTCH KIT+ BOSS	KIT EMBRAYAGE + TAMBOUR		9931900		9931900
MAXI KIT RACING 85 cc ghisa Ø 49,5 corsa 44	MAXI KIT RACING 85cc CAST IRON Ø 49,5 stroke 44	MAXI KIT RACING 85 cc fonte Ø 49,5 course 44		9921450		9921450
MAXI KIT RACING 86 cc alluminio Ø 50 corsa 44	MAXI KIT RACING 86cc ALLUMINIUM Ø 49,5 stroke 44	MAXI KIT RACING 86 cc aluminium Ø 50 course 44		9924240		9924240
MOLLE FRIZIONE	CLUTCH SPRINGS	RESSORTS EMBRAYAGE		9920580		9920580
MOTORINO AVVIAMENTO	STARTER ENGINE	DÉMARREUR ÉLECTRIQUE		MA00018		MA00018
SCARICO RACING omologato	RACING EXHAUST Approved	ÉCHAPPEMENT RACING homologué				
SERIE DISCHI frizione racing cellulosa/kevlar	CLUTCH PLATES RACING Cellulose/kevlar	JEU DISQUES embrayage racing cellulose/kevlar		9921180		9921180
SERIE DISCHI standard	CLUTCH PLATES Standard	JEU DISQUES standard		9920250		9920250
STATORE	STATOR	STATOR				
VALVOLA LAMELLARE	REED VALVE	CLAPET À LAMELLES		AM00045		AM00045
VALVOLA LAMELLARE TPR	REED VALVE TPR	CLAPET À LAMELLES TPR		9937820	9937820	9937820

APRILIA	APRILIA	APRILIA	APRILIA	APRILIA	APRILIA	APRILIA	APRILIA	APRILIA	APRILIA	APRILIA	APRILIA
MX MOTARD	PEGASO	RS	RS	RS	RS	RS	RS4	RS4 REPLICA	RX	RX	RX
95-03	92-94	91-92	93-95	96-98	99-05	06-10	11-13	14-16	89-90	03-04	06-10
50cc 2T LC	50cc 2T LC	50cc 2T LC	50cc 2T LC	50cc 2T LC	50cc 2T LC	50cc 2T LC	50cc 2T LC	50cc 2T LC	50cc 2T LC	50cc 2T LC	50cc 2T LC
AM 6	AM 3-4-5	AM 3-4-5	AM 3-4-5-6	AM 6	AM 6	D50B1	D50B1	D50B1	RV4	AM 6	D50B1
IM07017	IM07017	IM07017	IM07017	IM07017	IM07017	IM07066	IM07066	IM07066		IM07017	IM07066
9921720	9921720	9921720	9921720	9921720	9921720	9930150	9930150	9930150		9921720	9930150
IM07033	IM07033	IM07033	IM07033	IM07033	IM07033					IM07033	
IM07036	IM07036	IM07036	IM07036	IM07036	IM07036					IM07036	
9935000			9935000	9935000	9935000					9935000	
			9920020	9920020	9920020					9920020	
9910150	9910150	9910150	9910150	9910150	9910150					9910150	
9921690	9921690	9921690	9921690	9921690	9921690					9921690	
99CFAMT10	99CFAMT10	99CFAMT10	99CFAMT10	99CFAMT10	99CFAMT10					99CFAMT10	
99CFAMA10	99CFAMA10	99CFAMA10	99CFAMA10	99CFAMA10	99CFAMA10					99CFAMA10	
CT00746				CT00746	CT00746					CT00746	
9929180	9929180	9929180	9929180	9929180	9929180	9929190	9929190	9929190		9929180	9929190
9918550	9918550	9918550	9918550	9918550	9918550					9918550	
9916770 KT00098	9916770 KT00098	9916770 KT00098	9916770 KT00098	9916770 KT00098	9916770 KT00098	9927100	9927100	9927100		9916770 KT00098	9927100
9919250 KT00114	9919250 KT00114	9919250 KT00114	9919250 KT00114	9919250 KT00114	9919250 KT00114	9927020	9927020	9927020		9919250 KT00114	9927020
9919240	9919240	9919240	9919240	9919240	9919240					9919240	
9921150	9921150	9921150	9921150	9921150	9921150					9921150	
9924130	9924130	9924130	9924130	9924130	9924130					9924130	
9934500	9934500	9934500	9934500	9934500	9934500					9934500	
9919080			9919080	9919080	9919080					9919080	
9931910			9931910	9931910	9931910					9931910	
9930910	9930910	9930910	9930910	9930910	9930910	9930910	9930910	9930910		9930910	9930910
9931750	9931750	9931750	9931750	9931750	9931750	9931750	9931750	9931750		9931750	9931750
99F5MAM10	99F5MAM10	99F5MAM10	99F5MAM10	99F5MAM10	99F5MAM10					99F5MAM10	
9931900	9931900	9931900	9931900	9931900	9931900					9931900	
9921450	9921450	9921450	9921450	9921450	9921450					9921450	
9924240	9924240	9924240	9924240	9924240	9924240	9934270	9934270	9934270		9924240	9934270
9920580	9920580	9920580	9920580	9920580	9920580	9923180	9923180	9923180		9920580	9923180
	MA00018	MA00018	MA00018	MA00018	MA00018	MA00015	MA00015				
9921180	9921180	9921180	9921180	9921180	9921180	9923190	9923190	9923190		9921180	9923190
9920250	9920250	9920250	9920250	9920250	9920250					9920250	
AM00045	AM00045	AM00045	AM00045	AM00045	AM00045					AM00045	
9937820	9937820	9937820	9937820	9937820	9937820	9937820	9937820	9937820	9937820	9937820	9937820













APRILIA	APRILIA	APRILIA	APRILIA
RX	RX	RX 3-5 MARCE	RX ENDURO
06-13	14-16	91-94	95-03
50cc 2T LC	50cc 2T LC	50cc 2T LC	50cc 2T LC
D50B1	D50B1	AM 3-4-5	AM 6

IT	EN	FR					
ALBERO MOTORE standard	Standard Crankshaft	VILEBREQUIN standard		IM07066	IM07066	IM07017	IM07017
ALBERO MOTORE corsa 39 mm a piattelli pieni	Racing Crankshaft Stroke 39mm	VILEBREQUIN course 39 mm à contre-poids pleins		9930150	9930150	9921720	9921720
BIELLA Axe 16	CONROD Axle 16	BIELLE Axe 16				IM07033	IM07033
BIELLA Axe 18	CONROD Axle 18	BIELLE Axe 18				IM07036	IM07036
CAMBIO COMPLETO RACING	COMPLETE GEAR BOX RACING	BOÎTE DE VITESSES COMPLÈTE RACING					9935000
DESMODROMICO CAMBIO	SHIFT DRUM GEAR	BOÎTE DE VITESSES					
CENTRALINA AD ANTICIPO FISSO	CDI UNIT WITH VARIABLE ADVANCE (Ducati 6 coils)	BOÎTE ÉLECTRONIQUE numérique à avance variable volant Ducati 6 pôles				9910150	9910150
CENTRALINE RACING	RACING EU4 CONTROL UNIT	BOÎTIER ÉLECTRONIQUE RACING EU4				9921690	9921690
COPERCHIO FRIZIONE RACING TRASPARENTE	TRANSPARENT CRANKCASE COVER	TRANSPARENT COVER EMBRAYAGE				99CFAMT10	99CFAMT10
COPERCHIO FRIZIONE RACING ALLUMINIO	ALUMINIUM CRANKCASE COVER	ALUMINIUM COVER EMBRAYAGE				99CFAMA10	99CFAMA10
COLLETTORE ASPIRAZIONE STANDARD	STANDARD INLET MANIFOLD	COLLECTEUR D'ADMISSION STANDARD					CT00746
CUSCINETTI DI BANCO TPR Carbonitrurati Serie	BEARINGS TPR Carbonitrided	PALIERI DE VILEBREQUIN TPR Carbonitrurés Jeu		9929190	9929190	9929180	9929180
FRIZIONE a denti dritti	STRAIGHT TEETH CLUTCH	EMBRAYAGE À DENTS DROITES				9918550	9918550
GRUPPO TERMICO Ø STD Ghisa	CYLINDER KIT Ø Standard (CAST IRON)	CYLINDRE COMPLET Ø STD Fonte		9927100	9927100	9916770 KT00098	9916770 KT00098
GRUPPO TERMICO Ø Maggioreto Ghisa	CYLINDER KIT BIG BORE (CAST IRON)	CYLINDRE COMPLET Ø Majoré Fonte		9927020	9927020	9919250 KT00114	9919250 KT00114
GRUPPO TERMICO RACING Ø 49,5 Ghisa	CYLINDER KIT RACING Ø 49,5 (CAST IRON)	CYLINDRE COMPLET RACING Ø 49,5 Fonte				9919240	9919240
GRUPPO TERMICO RACING Ø 49,5 Ghisa testa scomposta	CYLINDER KIT RACING Ø 49,5 (CAST IRON) Decomposable head	CYLINDRE COMPLET RACING Ø 49,5 Fonte culasse décomposée				9921150	9921150
GRUPPO TERMICO RACING Ø 50 alluminio	CYLINDER KIT RACING Ø 50 (ALUMINIUM)	CYLINDRE COMPLET RACING Ø 50 aluminium				9924130	9924130
GRUPPO TERMICO RACING Ø Standard Alluminio	CYLINDER KIT RACING Ø Standard (ALUMINIUM)	CYLINDRE COMPLET RACING Ø Standard Aluminium				9934500	9934500
INGRANAGGIO 6 VELOCITA' 1ª serie	GEAR 6° SPEED AM6 1ª SERIES	ENGRENAGE 6 VITESSES 1ª SERIE					9919080
INGRANAGGIO 6 VELOCITA' 2ª serie	GEAR 6° SPEED AM6 2ª SERIES	ENGRENAGE 6 VITESSES 2ª SERIE					9931910
KIT ASPIRAZIONE COMPLETO TM 24	COMPLETE MIKUNI INLET KIT TM 24 TPR 360	KIT ASPIRATION COMPLET MIKUNI TM 24 TPR 360		9930910	9930910	9930910	9930910
KIT ASPIRAZIONE COMPLETO OKO 28	COMPLETE INLET KIT OKO 28 TPR 360	KIT ASPIRATION COMPLET OKO 28 TPR 360		9931750	9931750	9931750	9931750
KIT FRIZIONE RACING TPR FACTORY	TPR FACTORY RACING CLUTCH	KIT EMBRAYAGE RACING TPR FACTORY				99F5MAM10	99F5MAM10
KIT FRIZIONE + TAMBURO	HOUSING CLUTCH KIT+ BOSS	KIT EMBRAYAGE + TAMBOUR				9931900	9931900
MAXI KIT RACING 85 cc ghisa Ø 49,5 corsa 44	MAXI KIT RACING 85cc CAST IRON Ø 49,5 stroke 44	MAXI KIT RACING 85 cc fonte Ø 49,5 course 44				9921450	9921450
MAXI KIT RACING 86 cc alluminio Ø 50 corsa 44	MAXI KIT RACING 86cc ALLUMINIUM Ø 49,5 stroke 44	MAXI KIT RACING 86 cc aluminium Ø 50 course 44		9934270	9934270	9924240	9924240
MOLLE FRIZIONE	CLUTCH SPRINGS	RESSORTS EMBRAYAGE		9923180	9923180	9920580	9920580
MOTORINO AVVIAMENTO	STARTER ENGINE	DÉMARREUR ÉLECTRIQUE					
SCARICO RACING omologato	RACING EXHAUST Approved	ÉCHAPPEMENT RACING homologué					
SERIE DISCHI frizione racing cellulosa/kevlar	CLUTCH PLATES RACING Cellulose/kevlar	JEU DISQUES embrayage racing cellulose/kevlar		9923190	9923190	9921180	9921180
SERIE DISCHI standard	CLUTCH PLATES Standard	JEU DISQUES standard				9920250	9920250
STATORE	STATOR	STATOR					
VALVOLA LAMELLARE	REED VALVE	CLAPET À LAMELLES				AM00045	AM00045
VALVOLA LAMELLARE TPR	REED VALVE TPR	CLAPET À LAMELLES TPR		9937820	9937820	9937820	9937820

APRILIA	APRILIA	APRILIA	APRILIA	APRILIA	APRILIA	BETA	BETA	BETA	BETA	BETA	CH HUSQUARNA
RX RACING	SX	SX	SX	SX LIMITED EDITION	TUONO	RR 2T 50 EU4	RR 50 RACING EU4	RR ALU	RR ENDURO	RR MOTARD	SM
03-06	06-10	06-13	14-16	14-16	03-04	18-20	18-20	08-12	06-17	06-17	00-10
50cc 2T LC	50cc 2T LC	50cc 2T LC	50cc 2T LC	50cc 2T LC	50cc 2T LC	50cc 2T LC	50cc 2T LC	50cc 2T LC	50cc 2T LC	50cc 2T LC	50cc 2T LC
AM 6	D50B1	D50B1	D50B1	D50B1	AM 6	AM 6	AM 6	AM 6	AM 6	AM 6	AM 6
IM07017	IM07066	IM07066	IM07066	IM07066	IM07017	IM07017	IM07017	IM07017	IM07017	IM07017	IM07017
9921720	9930150	9930150	9930150	9930150	9921720	9921720	9921720	9921720	9921720	9921720	9921720
IM07033					IM07033	IM07033	IM07033	IM07033	IM07033	IM07033	IM07033
IM07036					IM07036	IM07036	IM07036	IM07036	IM07036	IM07036	IM07036
					9935000	9935000	9935000	9935000	9935000	9935000	9935000
					9920020	9920020	9920020	9920020	9920020	9920020	9920020
9910150					9910150						9910150
9921690					9921690	9934440	9934440				9921690
99CFAMT10					99CFAMT10	99CFAMT10	99CFAMT10	99CFAMT10	99CFAMT10	99CFAMT10	99CFAMT10
99CFAMA10					99CFAMA10	99CFAMA10	99CFAMA10	99CFAMA10	99CFAMA10	99CFAMA10	99CFAMA10
CT00746					CT00746	CT00746	CT00746				CT00746
9929180	9929190	9929190	9929190	9929190	9929180	9929180	9929180	9929180	9929180	9929180	9929180
9918550					9918550	9918550	9918550	9918550	9918550	9918550	9918550
9916770 KT00098	9927100	9927100	9927100	9927100	9916770 KT00098	9916770 KT00098	9916770 KT00098	9916770 KT00098	9916770 KT00098	9916770 KT00098	9916770 KT00098
9919250 KT00114	9927020	9927020	9927020	9927020	9919250 KT00114	9919250 KT00114	9919250 KT00114	9919250 KT00114	9919250 KT00114	9919250 KT00114	9919250 KT00114
9919240					9919240	9919240	9919240	9919240	9919240	9919240	9919240
9921150					9921150	9921150	9921150	9921150	9921150	9921150	9921150
9924130					9924130	9924130	9924130	9924130	9924130	9924130	9924130
9934500					9934500	9934500	9934500	9934500	9934500	9934500	9934500
					9919080	9919080	9919080	9919080	9919080	9919080	9919080
					9931910	9931910	9931910	9931910	9931910	9931910	9931910
9930910	9930910	9930910	9930910	9930910	9930910	9930910	9930910	9930910	9930910	9930910	9930910
9931750	9931750	9931750	9931750	9931750	9931750	9931750	9931750	9931750	9931750	9931750	9931750
99F5MAM10					99F5MAM10	99F5MAM10	99F5MAM10	99F5MAM10	99F5MAM10	99F5MAM10	99F5MAM10
9931900					9931900	9931900	9931900	9931900	9931900	9931900	9931900
9921450					9921450	9921450	9921450	9921450	9921450	9921450	9921450
9924240	9934270	9934270	9934270	9934270	9924240	9924240	9924240	9924240	9924240	9924240	9924240
9920580	9923180	9923180	9923180	9923180	9920580	9920580	9920580	9920580	9920580	9920580	9920580
					MA00018						
9921180	9923190	9923190	9923190	9923190	9921180	9921180	9921180	9921180	9921180	9921180	9921180
9920250					9920250	9920250	9920250	9920250	9920250	9920250	9920250
					ST00032	ST00032					
AM00045					AM00045	AM00045	AM00045	AM00045	AM00045	AM00045	AM00045
9937820	9937820	9937820	9937820	9937820	9937820	9937820	9937820	9937820	9937820	9937820	9937820

MOTO 50cc

CH HUSQUARNA	CH HUSQUARNA	CMC	CMC
WR	WSM	ENDURO	MOTARD
00-10	00-10	11-11	11-11
50cc 2T LC	50cc 2T LC	50cc 2T LC	50cc 2T LC
AM 6	AM 6	AM 6	AM 6

IT	EN	FR					
ALBERO MOTORE standard	Standard Crankshaft	VILEBREQUIN standard		IM07017	IM07017	IM07017	IM07017
ALBERO MOTORE corsa 39 mm a piattelli pieni	Racing Crankshaft Stroke 39mm	VILEBREQUIN course 39 mm à contre-poids pleins		9921720	9921720	9921720	9921720
BIELLA Axe 16	CONROD Axle 16	BIELLE Axe 16		IM07033	IM07033	IM07033	IM07033
BIELLA Axe 18	CONROD Axle 18	BIELLE Axe 18		IM07036	IM07036	IM07036	IM07036
CAMBIO COMPLETO RACING	COMPLETE GEAR BOX RACING	BOÎTE DE VITESSES COMPLÈTE RACING		9935000	9935000	9935000	9935000
DESMODROMICO CAMBIO	SHIFT DRUM GEAR	BOÎTE DE VITESSES		9920020	9920020	9920020	9920020
CENTRALINA AD ANTICIPO FISSO	CDI UNIT WITH VARIABLE ADVANCE (Ducati 6 coils)	BOÎTE ÉLECTRONIQUE numérique à avance variable volant Ducati 6 pôles		9910150	9910150		
CENTRALINE RACING	RACING EU4 CONTROL UNIT	BOÎTIER ÉLECTRONIQUE RACING EU4		9921690	9921690		
COPERCHIO FRIZIONE RACING TRASPARENTE	TRANSPARENT CRANKCASE COVER	TRANSPARENT COVER EMBRAYAGE		99CFAMT10	99CFAMT10	99CFAMT10	99CFAMT10
COPERCHIO FRIZIONE RACING ALLUMINIO	ALUMINIUM CRANKCASE COVER	ALUMINIUM COVER EMBRAYAGE		99CFAMA10	99CFAMA10	99CFAMA10	99CFAMA10
COLLETTORE ASPIRAZIONE STANDARD	STANDARD INLET MANIFOLD	COLLECTEUR D'ADMISSION STANDARD		CT00746	CT00746	CT00746	CT00746
CUSCINETTI DI BANCO TPR Carbonitrurati Serie	BEARINGS TPR Carbonitrided	PALIERI DE VILEBREQUIN TPR Carbonitrurés Jeu		9929180	9929180	9929180	9929180
FRIZIONE a denti dritti	STRAIGHT TEETH CLUTCH	EMBRAYAGE À DENTS DROITES		9918550	9918550	9918550	9918550
GRUPPO TERMICO Ø STD Ghisa	CYLINDER KIT Ø Standard (CAST IRON)	CYLINDRE COMPLET Ø STD Fonte		9916770 KT00098	9916770 KT00098	9916770 KT00098	9916770 KT00098
GRUPPO TERMICO Ø Maggioreto Ghisa	CYLINDER KIT BIG BORE (CAST IRON)	CYLINDRE COMPLET Ø Majoré Fonte		9919250 KT00114	9919250 KT00114	9919250 KT00114	9919250 KT00114
GRUPPO TERMICO RACING Ø 49,5 Ghisa	CYLINDER KIT RACING Ø 49,5 (CAST IRON)	CYLINDRE COMPLET RACING Ø 49,5 Fonte		9919240	9919240	9919240	9919240
GRUPPO TERMICO RACING Ø 49,5 Ghisa testa scomposta	CYLINDER KIT RACING Ø 49,5 (CAST IRON) Decomposable head	CYLINDRE COMPLET RACING Ø 49,5 Fonte culasse décomposée		9921150	9921150	9921150	9921150
GRUPPO TERMICO RACING Ø 50 alluminio	CYLINDER KIT RACING Ø 50 (ALUMINIUM)	CYLINDRE COMPLET RACING Ø 50 aluminium		9924130	9924130	9924130	9924130
GRUPPO TERMICO RACING Ø Standard Alluminio	CYLINDER KIT RACING Ø Standard (ALUMINIUM)	CYLINDRE COMPLET RACING Ø Standard Aluminium		9934500	9934500	9934500	9934500
INGRANAGGO 6 VELOCITA' 1ª serie	GEAR 6° SPEED AM6 1ª SERIES	ENGRENAGE 6 VITESSES 1ª SERIE		9919080	9919080	9919080	9919080
INGRANAGGO 6 VELOCITA' 2ª serie	GEAR 6° SPEED AM6 2ª SERIES	ENGRENAGE 6 VITESSES 2ª SERIE		9931910	9931910	9931910	9931910
KIT ASPIRAZIONE COMPLETO TM 24	COMPLETE MIKUNI INLET KIT TM 24 TPR 360	KIT ASPIRATION COMPLET MIKUNI TM 24 TPR 360		9930910	9930910	9930910	9930910
KIT ASPIRAZIONE COMPLETO OKO 28	COMPLETE INLET KIT OKO 28 TPR 360	KIT ASPIRATION COMPLET OKO 28 TPR 360		9931750	9931750	9931750	9931750
KIT FRIZIONE RACING TPR FACTORY	TPR FACTORY RACING CLUTCH	KIT EMBRAYAGE RACING TPR FACTORY		99F5MAM10	99F5MAM10	99F5MAM10	99F5MAM10
KIT FRIZIONE + TAMBURO	HOUSING CLUTCH KIT+ BOSS	KIT EMBRAYAGE + TAMBOUR		9931900	9931900	9931900	9931900
MAXI KIT RACING 85 cc ghisa Ø 49,5 corsa 44	MAXI KIT RACING 85cc CAST IRON Ø 49,5 stroke 44	MAXI KIT RACING 85 cc fonte Ø 49,5 course 44		9921450	9921450	9921450	9921450
MAXI KIT RACING 86 cc alluminio Ø 50 corsa 44	MAXI KIT RACING 86cc ALLUMINIUM Ø 49,5 stroke 44	MAXI KIT RACING 86 cc aluminium Ø 50 course 44		9924240	9924240	9924240	9924240
MOLLE FRIZIONE	CLUTCH SPRINGS	RESSORTS EMBRAYAGE		9920580	9920580	9920580	9920580
MOTORINO AVVIAMENTO	STARTER ENGINE	DÉMARREUR ÉLECTRIQUE					
SCARICO RACING omologato	RACING EXHAUST Approved	ÉCHAPPEMENT RACING homologué					
SERIE DISCHI frizione racing cellulosa/kevlar	CLUTCH PLATES RACING Cellulose/kevlar	JEU DISQUES embrayage racing cellulose/kevlar		9921180	9921180	9921180	9921180
SERIE DISCHI standard	CLUTCH PLATES Standard	JEU DISQUES standard		9920250	9920250	9920250	9920250
STATORE	STATOR	STATOR				ST00032	ST00032
VALVOLA LAMELLARE	REED VALVE	CLAPET À LAMELLES		AM00045	AM00045	AM00045	AM00045
VALVOLA LAMELLARE TPR	REED VALVE TPR	CLAPET À LAMELLES TPR		9937820	9937820	9937820	9937820

DERBI	DERBI	DERBI	DERBI	DERBI	DERBI	DERBI	DERBI	DERBI	DERBI	DERBI	DERBI
BULTACO LOBITO	GPR 2T	GPR 2T EU2	GPR NUDE	GPR NUDE & GPR NUDE TUNING	GPR NUDE SPORT	GPR R	GPR R EU2 - GPR REPLICA EU2	GPR RACING	GPR RACING EU2	GPR REPLICA	GPR REPLICA & GPR R EU2
98-01	13-13	09-10	04-05	06-08	06-06	97-00	08-08	04-05	06-06	99-01	06-06
50cc 2T LC	50cc 2T LC	50cc 2T LC	50cc 2T LC	50cc 2T LC	50cc 2T LC	50cc 2T LC	50cc 2T LC	50cc 2T LC	50cc 2T LC	50cc 2T LC	50cc 2T LC
	D50B0	D50B0	EBE050	D50B0	D50B0	EBE050	D50B0	EBE050	D50B0	EBE050	D50B0
	IM07066	IM07066		IM07066	IM07066		IM07066		IM07066		IM07066
	9930150	9930150		9930150	9930150		9930150		9930150		9930150
9929190	9929190	9929190	9929190	9929190	9929190	9929190	9929190	9929190	9929190	9929190	9929190
9927980 KT00115	9927100	9927100	9927980 KT00115	9927100	9927100	9927980 KT00115	9927100	9927980 KT00115	9927100	9927980 KT00115	9927100
	9927020	9927020	9928030	9927020	9927020	9928030	9927020	9928030	9927020	9928030	9927020
9930910	9930910	9930910	9930910	9930910	9930910	9930910	9930910	9930910	9930910	9930910	9930910
9931750	9931750	9931750	9931750	9931750	9931750	9931750	9931750	9931750	9931750	9931750	9931750
	9934270	9934270		9934270	9934270		9934270		9934270		9934270
9923180	9923180	9923180	9923180	9923180	9923180	9923180	9923180	9923180	9923180	9923180	9923180
							MA00015		MA00015		MA00015
9923190	9923190	9923190	9923190	9923190	9923190	9923190	9923190	9923190	9923190	9923190	9923190
9937820	9937820	9937820	9937820	9937820	9937820	9937820	9937820	9937820	9937820	9937820	9937820

DERBI	DERBI	DERBI	DERBI
GPR REPLICA 2T MALOSSÌ	GPR REPLICA PESEK EU2	GPR REPLICA RACING	GPR REPLICA RACING
07-07	07-07	02-02	03-03
50cc 2T LC	50cc 2T LC	50cc 2T LC	50cc 2T LC
D50B0	D50B0	EBE050	EBE050

IT	EN	FR				
ALBERO MOTORE standard	Standard Crankshaft	VILEBREQUIN standard		IM07066	IM07066	
ALBERO MOTORE corsa 39 mm a piattelli pieni	Racing Crankshaft Stroke 39mm	VILEBREQUIN course 39 mm à contre-poids pleins		9930150	9930150	
BIELLA Axe 16	CONROD Axle 16	BIELLE Axe 16				
BIELLA Axe 18	CONROD Axle 18	BIELLE Axe 18				
CAMBIO COMPLETO RACING	COMPLETE GEAR BOX RACING	BOÎTE DE VITESSES COMPLÈTE RACING				
DESMODROMICO CAMBIO	SHIFT DRUM GEAR	BOÎTE DE VITESSES				
CENTRALINA AD ANTICIPO FISSO	CDI UNIT WITH VARIABLE ADVANCE (Ducati 6 coils)	BOÎTE ÉLECTRONIQUE numérique à avance variable volant Ducati 6 pôles				
CENTRALINE RACING	RACING EU4 CONTROL UNIT	BOÎTIER ÉLECTRONIQUE RACING EU4				
COPERCHIO FRIZIONE RACING TRASPARENTE	TRANSPARENT CRANKCASE COVER	TRANSPARENT COVER EMBRAYAGE				
COPERCHIO FRIZIONE RACING ALLUMINIO	ALUMINIUM CRANKCASE COVER	ALUMINIUM COVER EMBRAYAGE				
COLLETTORE ASPIRAZIONE STANDARD	STANDARD INLET MANIFOLD	COLLECTEUR D'ADMISSION STANDARD				
CUSCINETTI DI BANCO TPR Carbonitrurati Serie	BEARINGS TPR Carbonitrided	PALIERI DE VILEBREQUIN TPR Carbonitrurés Jeu		9929190	9929190	9929190 9929190
FRIZIONE a denti dritti	STRAIGHT TEETH CLUTCH	EMBAYAGE À DENTS DROITES				
GRUPPO TERMICO Ø STD Ghisa	CYLINDER KIT Ø Standard (CAST IRON)	CYLINDRE COMPLET Ø STD Fonte		9927100	9927100	9927980 KT00115 9927980 KT00115
GRUPPO TERMICO Ø Maggioreto Ghisa	CYLINDER KIT BIG BORE (CAST IRON)	CYLINDRE COMPLET Ø Majoré Fonte		9927020	9927020	9928030 9928030
GRUPPO TERMICO RACING Ø 49,5 Ghisa	CYLINDER KIT RACING Ø 49,5 (CAST IRON)	CYLINDRE COMPLET RACING Ø 49,5 Fonte				
GRUPPO TERMICO RACING Ø 49,5 Ghisa testa scomposta	CYLINDER KIT RACING Ø 49,5 (CAST IRON) Decomposable head	CYLINDRE COMPLET RACING Ø 49,5 Fonte culasse décomposée				
GRUPPO TERMICO RACING Ø 50 alluminio	CYLINDER KIT RACING Ø 50 (ALUMINIUM)	CYLINDRE COMPLET RACING Ø 50 aluminium				
GRUPPO TERMICO RACING Ø Standard Alluminio	CYLINDER KIT RACING Ø Standard (ALUMINIUM)	CYLINDRE COMPLET RACING Ø Standard Aluminium				
INGRANAGGO 6 VELOCITA' 1ª serie	GEAR 6° SPEED AM6 1ª SERIES	ENGRENAGE 6 VITESSES 1ª SERIE				
INGRANAGGO 6 VELOCITA' 2ª serie	GEAR 6° SPEED AM6 2ª SERIES	ENGRENAGE 6 VITESSES 2ª SERIE				
KIT ASPIRAZIONE COMPLETO TM 24	COMPLETE MIKUNI INLET KIT TM 24 TPR 360	KIT ASPIRATION COMPLET MIKUNI TM 24 TPR 360		9930910	9930910	9930910 9930910
KIT ASPIRAZIONE COMPLETO OKO 28	COMPLETE INLET KIT OKO 28 TPR 360	KIT ASPIRATION COMPLET OKO 28 TPR 360		9931750	9931750	9931750 9931750
KIT FRIZIONE RACING TPR FACTORY	TPR FACTORY RACING CLUTCH	KIT EMBRAYAGE RACING TPR FACTORY				
KIT FRIZIONE + TAMBURO	HOUSING CLUTCH KIT+ BOSS	KIT EMBRAYAGE + TAMBOUR				
MAXI KIT RACING 85 cc ghisa Ø 49,5 corsa 44	MAXI KIT RACING 85cc CAST IRON Ø 49,5 stroke 44	MAXI KIT RACING 85 cc fonte Ø 49,5 course 44				
MAXI KIT RACING 86 cc alluminio Ø 50 corsa 44	MAXI KIT RACING 86cc ALLUMINIUM Ø 49,5 stroke 44	MAXI KIT RACING 86 cc aluminium Ø 50 course 44		9934270	9934270	
MOLLE FRIZIONE	CLUTCH SPRINGS	RESSORTS EMBRAYAGE		9923180	9923180	9923180 9923180
MOTORINO AVVIAMENTO	STARTER ENGINE	DÉMARREUR ÉLECTRIQUE			MA00015	
SCARICO RACING omologato	RACING EXHAUST Approved	ÉCHAPPEMENT RACING homologué				
SERIE DISCHI frizione racing cellulosa/kevlar	CLUTCH PLATES RACING Cellulose/kevlar	JEU DISQUES embrayage racing cellulose/kevlar		9923190	9923190	9923190 9923190
SERIE DISCHI standard	CLUTCH PLATES Standard	JEU DISQUES standard				
STATORE	STATOR	STATOR				
VALVOLA LAMELLARE	REED VALVE	CLAPET À LAMELLES				
VALVOLA LAMELLARE TPR	REED VALVE TPR	CLAPET À LAMELLES TPR		9937820	9937820	9937820 9937820

DERBI	DERBI	DERBI	DERBI
SENDA R DRD X-TREME 2T EU2	SENDA R DRD X-TREME 2T EURO2	SENDA R RACER	SENDA R X-RACE
14-15	10-12	03-03	04-04
50cc 2T LC	50cc 2T LC	50cc 2T LC	50cc 2T LC
D50B0	D50B0	EBS050	EBS050

IT	EN	FR				
ALBERO MOTORE standard	Standard Crankshaft	VILEBREQUIN standard		IM07066	IM07066	IM07040
ALBERO MOTORE corsa 39 mm a piattelli pieni	Racing Crankshaft Stroke 39mm	VILEBREQUIN course 39 mm à contre-poids pleins		9930150	9930150	
BIELLA Axe 16	CONROD Axle 16	BIELLE Axe 16				
BIELLA Axe 18	CONROD Axle 18	BIELLE Axe 18				
CAMBIO COMPLETO RACING	COMPLETE GEAR BOX RACING	BOÎTE DE VITESSES COMPLÈTE RACING				
DESMODROMICO CAMBIO	SHIFT DRUM GEAR	BOÎTE DE VITESSES				
CENTRALINA AD ANTICIPO FISSO	CDI UNIT WITH VARIABLE ADVANCE (Ducati 6 coils)	BOÎTE ÉLECTRONIQUE numérique à avance variable volant Ducati 6 pôles				
CENTRALINE RACING	RACING EU4 CONTROL UNIT	BOÎTIER ÉLECTRONIQUE RACING EU4				
COPERCHIO FRIZIONE RACING TRASPARENTE	TRANSPARENT CRANKCASE COVER	TRANSPARENT COVER EMBRAYAGE				
COPERCHIO FRIZIONE RACING ALLUMINIO	ALUMINIUM CRANKCASE COVER	ALUMINIUM COVER EMBRAYAGE				
COLLETTORE ASPIRAZIONE STANDARD	STANDARD INLET MANIFOLD	COLLECTEUR D'ADMISSION STANDARD				
CUSCINETTI DI BANCO TPR Carbonitrurati Serie	BEARINGS TPR Carbonitrided	PALIERI DE VILEBREQUIN TPR Carbonitrurés Jeu		9929190	9929190	9929190
FRIZIONE a denti dritti	STRAIGHT TEETH CLUTCH	EMBRAYAGE À DENTS DROITES				
GRUPPO TERMICO Ø STD Ghisa	CYLINDER KIT Ø Standard (CAST IRON)	CYLINDRE COMPLET Ø STD Fonte		9927100	9927100	9927980 KT00115
GRUPPO TERMICO Ø Maggioreto Ghisa	CYLINDER KIT BIG BORE (CAST IRON)	CYLINDRE COMPLET Ø Majoré Fonte		9927020	9927020	9928030
GRUPPO TERMICO RACING Ø 49,5 Ghisa	CYLINDER KIT RACING Ø 49,5 (CAST IRON)	CYLINDRE COMPLET RACING Ø 49,5 Fonte				
GRUPPO TERMICO RACING Ø 49,5 Ghisa testa scomposta	CYLINDER KIT RACING Ø 49,5 (CAST IRON) Decomposable head	CYLINDRE COMPLET RACING Ø 49,5 Fonte culasse décomposée				
GRUPPO TERMICO RACING Ø 50 alluminio	CYLINDER KIT RACING Ø 50 (ALUMINIUM)	CYLINDRE COMPLET RACING Ø 50 aluminium				
GRUPPO TERMICO RACING Ø Standard Alluminio	CYLINDER KIT RACING Ø Standard (ALUMINIUM)	CYLINDRE COMPLET RACING Ø Standard Aluminium				
INGRANAGGIO 6 VELOCITA' 1ª serie	GEAR 6° SPEED AM6 1ª SERIES	ENGRENAGE 6 VITESSES 1ª SERIE				
INGRANAGGIO 6 VELOCITA' 2ª serie	GEAR 6° SPEED AM6 2ª SERIES	ENGRENAGE 6 VITESSES 2ª SERIE				
KIT ASPIRAZIONE COMPLETO TM 24	COMPLETE MIKUNI INLET KIT TM 24 TPR 360	KIT ASPIRATION COMPLET MIKUNI TM 24 TPR 360		9930910	9930910	9930910
KIT ASPIRAZIONE COMPLETO OKO 28	COMPLETE INLET KIT OKO 28 TPR 360	KIT ASPIRATION COMPLET OKO 28 TPR 360		9931750	9931750	9931750
KIT FRIZIONE RACING TPR FACTORY	TPR FACTORY RACING CLUTCH	KIT EMBRAYAGE RACING TPR FACTORY				
KIT FRIZIONE + TAMBURO	HOUSING CLUTCH KIT+ BOSS	KIT EMBRAYAGE + TAMBOUR				
MAXI KIT RACING 85 cc ghisa Ø 49,5 corsa 44	MAXI KIT RACING 85cc CAST IRON Ø 49,5 stroke 44	MAXI KIT RACING 85 cc fonte Ø 49,5 course 44				
MAXI KIT RACING 86 cc alluminio Ø 50 corsa 44	MAXI KIT RACING 86cc ALLUMINIUM Ø 49,5 stroke 44	MAXI KIT RACING 86 cc aluminium Ø 50 course 44		9934270	9934270	
MOLLE FRIZIONE	CLUTCH SPRINGS	RESSORTS EMBRAYAGE		9923180	9923180	9923180
MOTORINO AVVIAMENTO	STARTER ENGINE	DÉMARREUR ÉLECTRIQUE				
SCARICO RACING omologato	RACING EXHAUST Approved	ÉCHAPPEMENT RACING homologué				
SERIE DISCHI frizione racing cellulosa/kevlar	CLUTCH PLATES RACING Cellulose/kevlar	JEU DISQUES embrayage racing cellulose/kevlar		9923190	9923190	9923190
SERIE DISCHI standard	CLUTCH PLATES Standard	JEU DISQUES standard				
STATORE	STATOR	STATOR				
VALVOLA LAMELLARE	REED VALVE	CLAPET À LAMELLES				
VALVOLA LAMELLARE TPR	REED VALVE TPR	CLAPET À LAMELLES TPR		9937820	9937820	9937820

DERBI	DERBI	DERBI	DERBI	DERBI	DERBI	DERBI	DERBI	DERBI	DERBI	DERBI	DERBI
SENDA R X-RACE	SENDA R X-RACE 2T EU2	SENDA R X-RACE EU2	SENDA R X-RACE EU2	SENDA R X-TREME	SENDA R X-TREME	SENDA R X-TREME 2T EU2	SENDA R X-TREME EU2	SENDA R X-TREME EU2	SENDA R X-TREME EU2	SENDA R X-TREME EU2	SENDA SM
05-05	10-10	06-06	07-09	03-03	05-05	10-10	04-04	05-06	07-07	08-08	00-01
50cc 2T LC	50cc 2T LC	50cc 2T LC	50cc 2T LC	50cc 2T LC	50cc 2T LC	50cc 2T LC	50cc 2T LC	50cc 2T LC	50cc 2T LC	50cc 2T LC	50cc 2T LC
EBS050	D50B0	D50B0	D50B0	EBS050	EBS050	D50B0	EBS050	D50B0	D50B0	D50B0	EBS050
IM07040	IM07066	IM07066	IM07066	IM07040	IM07040	IM07066	IM07040	IM07066	IM07066	IM07066	IM07040
	9930150	9930150	9930150			9930150		9930150	9930150	9930150	
9929190	9929190	9929190	9929190	9929190	9929190	9929190	9929190	9929190	9929190	9929190	9929190
9927980 KT00115	9927100	9927100	9927100	9927980 KT00115	9927980 KT00115	9927100	9927980 KT00115	9927100	9927100	9927100	9927980 KT00115
9928030	9927020	9927020	9927020	9928030	9928030	9927020	9928030	9927020	9927020	9927020	9928030
9930910	9930910	9930910	9930910	9930910	9930910	9930910	9930910	9930910	9930910	9930910	9930910
9931750	9931750	9931750	9931750	9931750	9931750	9931750	9931750	9931750	9931750	9931750	9931750
	9934270	9934270	9934270			9934270		9934270	9934270	9934270	
9923180	9923180	9923180	9923180	9923180	9923180	9923180	9923180	9923180	9923180	9923180	9923180
9923190	9923190	9923190	9923190	9923190	9923190	9923190	9923190	9923190	9923190	9923190	9923190
9937820	9937820	9937820	9937820	9937820	9937820	9937820	9937820	9937820	9937820	9937820	9937820

DERBI	DERBI	DERBI	DERBI
SENDA SM DRD EDITION BLACK	SENDA SM DRD EU1 EU1R	SENDA SM DRD PRO EU2	SENDA SM DRD PRO EU2 2VER
05-05	02-03	05-11	05-08
50cc 2T LC	50cc 2T LC	50cc 2T LC	50cc 2T LC
EBS050	EBS050	D50B0	D50B0









IT	EN	FR					
ALBERO MOTORE standard	Standard Crankshaft	VILEBREQUIN standard		IM07040	IM07040	IM07066	IM07066
ALBERO MOTORE corsa 39 mm a piatti pieni	Racing Crankshaft Stroke 39mm	VILEBREQUIN course 39 mm à contre-poids pleins				9930150	9930150
BIELLA Axe 16	CONROD Axle 16	BIELLE Axe 16					
BIELLA Axe 18	CONROD Axle 18	BIELLE Axe 18					
CAMBIO COMPLETO RACING	COMPLETE GEAR BOX RACING	BOÎTE DE VITESSES COMPLÈTE RACING					
DESMODROMICO CAMBIO	SHIFT DRUM GEAR	BOÎTE DE VITESSES					
CENTRALINA AD ANTICIPO FISSO	CDI UNIT WITH VARIABLE ADVANCE (Ducati 6 coils)	BOÎTE ÉLECTRONIQUE numérique à avance variable volant Ducati 6 pôles					
CENTRALINE RACING	RACING EU4 CONTROL UNIT	BOÎTIER ÉLECTRONIQUE RACING EU4					
COPERCHIO FRIZIONE RACING TRASPARENTE	TRANSPARENT CRANKCASE COVER	TRANSPARENT COVER EMBRAYAGE					
COPERCHIO FRIZIONE RACING ALLUMINIO	ALUMINIUM CRANKCASE COVER	ALUMINIUM COVER EMBRAYAGE					
COLLETTORE ASPIRAZIONE STANDARD	STANDARD INLET MANIFOLD	COLLECTEUR D'ADMISSION STANDARD					
CUSCINETTI DI BANCO TPR Carbonitrurati Serie	BEARINGS TPR Carbonitrided	PALIERI DE VILEBREQUIN TPR Carbonitrurés Jeu		9929190	9929190	9929190	9929190
FRIZIONE a denti dritti	STRAIGHT TEETH CLUTCH	EMBRAYAGE À DENTS DROITES					
GRUPPO TERMICO Ø STD Ghisa	CYLINDER KIT Ø Standard (CAST IRON)	CYLINDRE COMPLET Ø STD Fonte		9927980 KT00115	9927980 KT00115	9927100	9927100
GRUPPO TERMICO Ø Maggioreto Ghisa	CYLINDER KIT BIG BORE (CAST IRON)	CYLINDRE COMPLET Ø Majoré Fonte		9928030	9928030	9927020	9927020
GRUPPO TERMICO RACING Ø 49,5 Ghisa	CYLINDER KIT RACING Ø 49,5 (CAST IRON)	CYLINDRE COMPLET RACING Ø 49,5 Fonte					
GRUPPO TERMICO RACING Ø 49,5 Ghisa testa scomposta	CYLINDER KIT RACING Ø 49,5 (CAST IRON) Decomposable head	CYLINDRE COMPLET RACING Ø 49,5 Fonte culasse décomposée					
GRUPPO TERMICO RACING Ø 50 alluminio	CYLINDER KIT RACING Ø 50 (ALUMINIUM)	CYLINDRE COMPLET RACING Ø 50 aluminium					
GRUPPO TERMICO RACING Ø Standard Alluminio	CYLINDER KIT RACING Ø Standard (ALUMINIUM)	CYLINDRE COMPLET RACING Ø Standard Aluminium					
INGRANAGGIO 6 VELOCITA' 1ª serie	GEAR 6° SPEED AM6 1ª SERIES	ENGRENAGE 6 VITESSES 1ª SERIE					
INGRANAGGIO 6 VELOCITA' 2ª serie	GEAR 6° SPEED AM6 2ª SERIES	ENGRENAGE 6 VITESSES 2ª SERIE					
KIT ASPIRAZIONE COMPLETO TM 24	COMPLETE MIKUNI INLET KIT TM 24 TPR 360	KIT ASPIRATION COMPLET MIKUNI TM 24 TPR 360		9930910	9930910	9930910	9930910
KIT ASPIRAZIONE COMPLETO OKO 28	COMPLETE INLET KIT OKO 28 TPR 360	KIT ASPIRATION COMPLET OKO 28 TPR 360		9931750	9931750	9931750	9931750
KIT FRIZIONE RACING TPR FACTORY	TPR FACTORY RACING CLUTCH	KIT EMBRAYAGE RACING TPR FACTORY					
KIT FRIZIONE + TAMBURO	HOUSING CLUTCH KIT+ BOSS	KIT EMBRAYAGE + TAMBOUR					
MAXI KIT RACING 85 cc ghisa Ø 49,5 corsa 44	MAXI KIT RACING 85cc CAST IRON Ø 49,5 stroke 44	MAXI KIT RACING 85 cc fonte Ø 49,5 course 44					
MAXI KIT RACING 86 cc alluminio Ø 50 corsa 44	MAXI KIT RACING 86cc ALLUMINIUM Ø 49,5 stroke 44	MAXI KIT RACING 86 cc aluminium Ø 50 course 44				9934270	9934270
MOLLE FRIZIONE	CLUTCH SPRINGS	RESSORTS EMBRAYAGE		9923180	9923180	9923180	9923180
MOTORINO AVVIAMENTO	STARTER ENGINE	DÉMARREUR ÉLECTRIQUE				MA00015	
SCARICO RACING omologato	RACING EXHAUST Approved	ÉCHAPPEMENT RACING homologué					
SERIE DISCHI frizione racing cellulosa/kevlar	CLUTCH PLATES RACING Cellulose/kevlar	JEU DISQUES embrayage racing cellulose/kevlar		9923190	9923190	9923190	9923190
SERIE DISCHI standard	CLUTCH PLATES Standard	JEU DISQUES standard					
STATORE	STATOR	STATOR					
VALVOLA LAMELLARE	REED VALVE	CLAPET À LAMELLES					
VALVOLA LAMELLARE TPR	REED VALVE TPR	CLAPET À LAMELLES TPR		9937820	9937820	9937820	9937820

DERBI	DERBI	DERBI	DERBI
SENDA SM X-RACE EU2 2VER	SENDA SM X-TREME	SENDA SM X-TREME	SENDA SM X-TREME 2T EU2
07-09	02-02	03-03	10-10
50cc 2T LC	50cc 2T LC	50cc 2T LC	50cc 2T LC
D50B0	EBS050	EBS050	D50B0

IT	EN	FR					
ALBERO MOTORE standard	Standard Crankshaft	VILEBREQUIN standard		IM07066	IM07040	IM07040	IM07066
ALBERO MOTORE corsa 39 mm a piattelli pieni	Racing Crankshaft Stroke 39mm	VILEBREQUIN course 39 mm à contre-poids pleins		9930150			9930150
BIELLA Axe 16	CONROD Axle 16	BIELLE Axe 16					
BIELLA Axe 18	CONROD Axle 18	BIELLE Axe 18					
CAMBIO COMPLETO RACING	COMPLETE GEAR BOX RACING	BOÎTE DE VITESSES COMPLÈTE RACING					
DESMODROMICO CAMBIO	SHIFT DRUM GEAR	BOÎTE DE VITESSES					
CENTRALINA AD ANTICIPO FISSO	CDI UNIT WITH VARIABLE ADVANCE (Ducati 6 coils)	BOÎTE ÉLECTRONIQUE numérique à avance variable volant Ducati 6 pôles					
CENTRALINE RACING	RACING EU4 CONTROL UNIT	BOÎTIER ÉLECTRONIQUE RACING EU4					
COPERCHIO FRIZIONE RACING TRASPARENTE	TRANSPARENT CRANKCASE COVER	TRANSPARENT COVER EMBRAYAGE					
COPERCHIO FRIZIONE RACING ALLUMINIO	ALUMINIUM CRANKCASE COVER	ALUMINIUM COVER EMBRAYAGE					
COLLETTORE ASPIRAZIONE STANDARD	STANDARD INLET MANIFOLD	COLLECTEUR D'ADMISSION STANDARD					
CUSCINETTI DI BANCO TPR Carbonitrurati Serie	BEARINGS TPR Carbonitrided	PALIERI DE VILEBREQUIN TPR Carbonitrurés Jeu		9929190	9929190	9929190	9929190
FRIZIONE a denti dritti	STRAIGHT TEETH CLUTCH	EMBRAYAGE À DENTS DROITES					
GRUPPO TERMICO Ø STD Ghisa	CYLINDER KIT Ø Standard (CAST IRON)	CYLINDRE COMPLET Ø STD Fonte		9927100	9927980 KT00115	9927980 KT00115	9927100
GRUPPO TERMICO Ø Maggioreto Ghisa	CYLINDER KIT BIG BORE (CAST IRON)	CYLINDRE COMPLET Ø Majoré Fonte		9927020	9928030	9928030	9927020
GRUPPO TERMICO RACING Ø 49,5 Ghisa	CYLINDER KIT RACING Ø 49,5 (CAST IRON)	CYLINDRE COMPLET RACING Ø 49,5 Fonte					
GRUPPO TERMICO RACING Ø 49,5 Ghisa testa scomposta	CYLINDER KIT RACING Ø 49,5 (CAST IRON) Decomposable head	CYLINDRE COMPLET RACING Ø 49,5 Fonte culasse décomposée					
GRUPPO TERMICO RACING Ø 50 alluminio	CYLINDER KIT RACING Ø 50 (ALUMINIUM)	CYLINDRE COMPLET RACING Ø 50 aluminium					
GRUPPO TERMICO RACING Ø Standard Alluminio	CYLINDER KIT RACING Ø Standard (ALUMINIUM)	CYLINDRE COMPLET RACING Ø Standard Aluminium					
INGRANAGGIO 6 VELOCITA' 1ª serie	GEAR 6° SPEED AM6 1ª SERIES	ENGRENAGE 6 VITESSES 1ª SERIE					
INGRANAGGIO 6 VELOCITA' 2ª serie	GEAR 6° SPEED AM6 2ª SERIES	ENGRENAGE 6 VITESSES 2ª SERIE					
KIT ASPIRAZIONE COMPLETO TM 24	COMPLETE MIKUNI INLET KIT TM 24 TPR 360	KIT ASPIRATION COMPLET MIKUNI TM 24 TPR 360		9930910	9930910	9930910	9930910
KIT ASPIRAZIONE COMPLETO OKO 28	COMPLETE INLET KIT OKO 28 TPR 360	KIT ASPIRATION COMPLET OKO 28 TPR 360		9931750	9931750	9931750	9931750
KIT FRIZIONE RACING TPR FACTORY	TPR FACTORY RACING CLUTCH	KIT EMBRAYAGE RACING TPR FACTORY					
KIT FRIZIONE + TAMBURO	HOUSING CLUTCH KIT+ BOSS	KIT EMBRAYAGE + TAMBOUR					
MAXI KIT RACING 85 cc ghisa Ø 49,5 corsa 44	MAXI KIT RACING 85cc CAST IRON Ø 49,5 stroke 44	MAXI KIT RACING 85 cc fonte Ø 49,5 course 44					
MAXI KIT RACING 86 cc alluminio Ø 50 corsa 44	MAXI KIT RACING 86cc ALLUMINIUM Ø 49,5 stroke 44	MAXI KIT RACING 86 cc aluminium Ø 50 course 44		9934270			9934270
MOLLE FRIZIONE	CLUTCH SPRINGS	RESSORTS EMBRAYAGE		9923180	9923180	9923180	9923180
MOTORINO AVVIAMENTO	STARTER ENGINE	DÉMARREUR ÉLECTRIQUE					
SCARICO RACING omologato	RACING EXHAUST Approved	ÉCHAPPEMENT RACING homologué					
SERIE DISCHI frizione racing cellulosa/kevlar	CLUTCH PLATES RACING Cellulose/kevlar	JEU DISQUES embrayage racing cellulose/kevlar		9923190	9923190	9923190	9923190
SERIE DISCHI standard	CLUTCH PLATES Standard	JEU DISQUES standard					
STATORE	STATOR	STATOR					
VALVOLA LAMELLARE	REED VALVE	CLAPET À LAMELLES					
VALVOLA LAMELLARE TPR	REED VALVE TPR	CLAPET À LAMELLES TPR		9937820	9937820	9937820	9937820



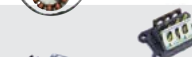































DERBI	DERBI	DERBI	DERBI	DERBI	FANTIC	FANTIC	FANTIC	FANTIC	FANTIC	FANTIC	FANTIC
SENDA SM X-TREME EU2	SENDA SM X-TREME EU2	SENDA SM X-TREME EU2	SENDA SM X-TREME EU2	SENDA SM X-TREME EU2 2A EDIZIONE	CABALLERO MOTARD	CABALLERO MOTARD	CABALLERO MOTARD COMPETITION	CABALLERO MOTARD COMPETITION	CABALLERO REGOLARITÀ	CABALLERO REGOLARITÀ	CABALLERO REGOLARITÀ COMPETITION
04-04	05-06	07-07	08-08	05-05	06-09	10-10	06-09	10-10	06-09	10-10	06-09
50cc 2T LC	50cc 2T LC	50cc 2T LC	50cc 2T LC	50cc 2T LC	50cc 2T LC	50cc 2T LC	50cc 2T LC	50cc 2T LC	50cc 2T LC	50cc 2T LC	50cc 2T LC
EBS050	D50B0	D50B0	D50B0	EBS050	AM 6	AM 6	AM 6	AM 6	AM 6	AM 6	AM 6
IM07040	IM07066	IM07066	IM07066	IM07040	IM07017	IM07017	IM07017	IM07017	IM07017	IM07017	IM07017
	9930150	9930150	9930150		9921720	9921720	9921720	9921720	9921720	9921720	9921720
					IM07033	IM07033	IM07033	IM07033	IM07033	IM07033	IM07033
					IM07036	IM07036	IM07036	IM07036	IM07036	IM07036	IM07036
					9935000	9935000	9935000	9935000	9935000	9935000	9935000
					9920020	9920020	9920020	9920020	9920020	9920020	9920020
					9921690	9921690	9921690	9921690	9921690	9921690	9921690
					99CFAMT10	99CFAMT10	99CFAMT10	99CFAMT10	99CFAMT10	99CFAMT10	99CFAMT10
					99CFAMA10	99CFAMA10	99CFAMA10	99CFAMA10	99CFAMA10	99CFAMA10	99CFAMA10
					CT00746	CT00746	CT00746	CT00746	CT00746	CT00746	CT00746
9929190	9929190	9929190	9929190	9929190	9929180	9929180	9929180	9929180	9929180	9929180	9929180
					9918550	9918550	9918550	9918550	9918550	9918550	9918550
9927980 KT00115	9927100	9927100	9927100	9927980 KT00115	9916770 KT00098	9916770 KT00098	9916770 KT00098	9916770 KT00098	9916770 KT00098	9916770 KT00098	9916770 KT00098
9928030	9927020	9927020	9927020	9928030	9919250 KT00114	9919250 KT00114	9919250 KT00114	9919250 KT00114	9919250 KT00114	9919250 KT00114	9919250 KT00114
					9919240	9919240	9919240	9919240	9919240	9919240	9919240
					9921150	9921150	9921150	9921150	9921150	9921150	9921150
					9924130	9924130	9924130	9924130	9924130	9924130	9924130
					9934500	9934500	9934500	9934500	9934500	9934500	9934500
					9919080	9919080	9919080	9919080	9919080	9919080	9919080
					9931910	9931910	9931910	9931910	9931910	9931910	9931910
9930910	9930910	9930910	9930910	9930910	9930910	9930910	9930910	9930910	9930910	9930910	9930910
9931750	9931750	9931750	9931750	9931750	9931750	9931750	9931750	9931750	9931750	9931750	9931750
					99F5MAM10	99F5MAM10	99F5MAM10	99F5MAM10	99F5MAM10	99F5MAM10	99F5MAM10
					9931900	9931900	9931900	9931900	9931900	9931900	9931900
					9921450	9921450	9921450	9921450	9921450	9921450	9921450
	9934270	9934270	9934270		9924240	9924240	9924240	9924240	9924240	9924240	9924240
9923180	9923180	9923180	9923180	9923180	9920580	9920580	9920580	9920580	9920580	9920580	9920580
9923190	9923190	9923190	9923190	9923190	9921180	9921180	9921180	9921180	9921180	9921180	9921180
					9920250	9920250	9920250	9920250	9920250	9920250	9920250
					ST00032		ST00032		ST00032		ST00032
					AM00045	AM00045	AM00045	AM00045	AM00045	AM00045	AM00045
9937820	9937820	9937820	9937820	9937820	9937820	9937820	9937820	9937820	9937820	9937820	9937820

FANTIC	FANTIC	FANTIC	FANTIC
CABALLERO REGULARITÀ COMPETITION	ENDURO COMPETITION EU4	ENDURO PERFORMANCE EU4	MOTARD COMPETITION EU4
10-10	18-20	18-20	18-20
50cc 2T LC	50cc 2T LC	50cc 2T LC	50cc 2T LC
AM 6	AM 6	AM 6	AM 6



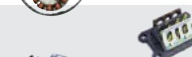







IT	EN	FR				
ALBERO MOTORE standard	Standard Crankshaft	VILEBREQUIN standard		IM07017	IM07017	IM07017
ALBERO MOTORE corsa 39 mm a piattelli pieni	Racing Crankshaft Stroke 39mm	VILEBREQUIN course 39 mm à contre-poids pleins		9921720	9921720	9921720
BIELLA Axe 16	CONROD Axle 16	BIELLE Axe 16		IM07033	IM07033	IM07033
BIELLA Axe 18	CONROD Axle 18	BIELLE Axe 18		IM07036	IM07036	IM07036
CAMBIO COMPLETO RACING	COMPLETE GEAR BOX RACING	BOÎTE DE VITESSES COMPLÈTE RACING		9935000	9935000	9935000
DESMODROMICO CAMBIO	SHIFT DRUM GEAR	BOÎTE DE VITESSES		9920020	9920020	9920020
CENTRALINA AD ANTICIPO FISSO	CDI UNIT WITH VARIABLE ADVANCE (Ducati 6 coils)	BOÎTE ÉLECTRONIQUE numérique à avance variable volant Ducati 6 pôles		9921690	9934440	9934440
CENTRALINE RACING	RACING EU4 CONTROL UNIT	BOÎTIER ÉLECTRONIQUE RACING EU4		9921690	9934440	9934440
COPERCHIO FRIZIONE RACING TRASPARENTE	TRANSPARENT CRANKCASE COVER	TRANSPARENT COVER EMBRAYAGE		99CFAMT10	99CFAMT10	99CFAMT10
COPERCHIO FRIZIONE RACING ALLUMINIO	ALUMINIUM CRANKCASE COVER	ALUMINIUM COVER EMBRAYAGE		99CFAMA10	99CFAMA10	99CFAMA10
COLLETTORE ASPIRAZIONE STANDARD	STANDARD INLET MANIFOLD	COLLECTEUR D'ADMISSION STANDARD		CT00746	CT00746	CT00746
CUSCINETTI DI BANCO TPR Carbonitrurati Serie	BEARINGS TPR Carbonitrided	PALIERI DE VILEBREQUIN TPR Carbonitrurés Jeu		9929180	9929180	9929180
FRIZIONE a denti dritti	STRAIGHT TEETH CLUTCH	EMBRAYAGE À DENTS DROITES		9918550	9918550	9918550
GRUPPO TERMICO Ø STD Ghisa	CYLINDER KIT Ø Standard (CAST IRON)	CYLINDRE COMPLET Ø STD Fonte		9916770 KT00098	9916770 KT00098	9916770 KT00098
GRUPPO TERMICO Ø Maggioreto Ghisa	CYLINDER KIT BIG BORE (CAST IRON)	CYLINDRE COMPLET Ø Majoré Fonte		9919250 KT00114	9919250 KT00114	9919250 KT00114
GRUPPO TERMICO RACING Ø 49,5 Ghisa	CYLINDER KIT RACING Ø 49,5 (CAST IRON)	CYLINDRE COMPLET RACING Ø 49,5 Fonte		9919240	9919240	9919240
GRUPPO TERMICO RACING Ø 49,5 Ghisa testa scomposta	CYLINDER KIT RACING Ø 49,5 (CAST IRON) Decomposable head	CYLINDRE COMPLET RACING Ø 49,5 Fonte culasse décomposée		9921150	9921150	9921150
GRUPPO TERMICO RACING Ø 50 alluminio	CYLINDER KIT RACING Ø 50 (ALUMINIUM)	CYLINDRE COMPLET RACING Ø 50 aluminium		9924130	9924130	9924130
GRUPPO TERMICO RACING Ø Standard Alluminio	CYLINDER KIT RACING Ø Standard (ALUMINIUM)	CYLINDRE COMPLET RACING Ø Standard Aluminium		9934500	9934500	9934500
INGRANAGGIO 6 VELOCITA' 1ª serie	GEAR 6° SPEED AM6 1ª SERIES	ENGRENAGE 6 VITESSES 1ª SERIE		9919080	9919080	9919080
INGRANAGGIO 6 VELOCITA' 2ª serie	GEAR 6° SPEED AM6 2ª SERIES	ENGRENAGE 6 VITESSES 2ª SERIE		9931910	9931910	9931910
KIT ASPIRAZIONE COMPLETO TM 24	COMPLETE MIKUNI INLET KIT TM 24 TPR 360	KIT ASPIRATION COMPLET MIKUNI TM 24 TPR 360		9930910	9930910	9930910
KIT ASPIRAZIONE COMPLETO OKO 28	COMPLETE INLET KIT OKO 28 TPR 360	KIT ASPIRATION COMPLET OKO 28 TPR 360		9931750	9931750	9931750
KIT FRIZIONE RACING TPR FACTORY	TPR FACTORY RACING CLUTCH	KIT EMBRAYAGE RACING TPR FACTORY		99F5MAM10	99F5MAM10	99F5MAM10
KIT FRIZIONE + TAMBURO	HOUSING CLUTCH KIT+ BOSS	KIT EMBRAYAGE + TAMBOUR		9931900	9931900	9931900
MAXI KIT RACING 85 cc ghisa Ø 49,5 corsa 44	MAXI KIT RACING 85cc CAST IRON Ø 49,5 stroke 44	MAXI KIT RACING 85 cc fonte Ø 49,5 course 44		9921450	9921450	9921450
MAXI KIT RACING 86 cc alluminio Ø 50 corsa 44	MAXI KIT RACING 86cc ALLUMINIUM Ø 49,5 stroke 44	MAXI KIT RACING 86 cc aluminium Ø 50 course 44		9924240	9924240	9924240
MOLLE FRIZIONE	CLUTCH SPRINGS	RESSORTS EMBRAYAGE		9920580	9920580	9920580
MOTORINO AVVIAMENTO	STARTER ENGINE	DÉMARREUR ÉLECTRIQUE				
SCARICO RACING omologato	RACING EXHAUST Approved	ÉCHAPPEMENT RACING homologué				
SERIE DISCHI frizione racing cellulosa/kevlar	CLUTCH PLATES RACING Cellulose/kevlar	JEU DISQUES embrayage racing cellulose/kevlar		9921180	9921180	9921180
SERIE DISCHI standard	CLUTCH PLATES Standard	JEU DISQUES standard		9920250	9920250	9920250
STATORE	STATOR	STATOR		ST00032	ST00032	ST00032
VALVOLA LAMELLARE	REED VALVE	CLAPET À LAMELLES		AM00045	AM00045	AM00045
VALVOLA LAMELLARE TPR	REED VALVE TPR	CLAPET À LAMELLES TPR		9937820	9937820	9937820

FANTIC	GILERA	GILERA	GILERA	GILERA	GILERA	GILERA	GILERA	GILERA	GILERA	HM	HM
MOTARD PERFORMANCE EU4	GSM	RCR	RCR	RCR	RCR (CHE-SYC)	SMT	SMT	SMT	SMT RACING	BAJA, DERA-PAGE BASIC	CMC
18-20	01-01	03-03	06-07	11-12	13-15	03-05	06-12	13-17	11-12	10-11	10-11
50cc 2T LC	50cc 2T LC	50cc 2T LC	50cc 2T LC	50cc 2T LC	50cc 2T LC	50cc 2T LC	50cc 2T LC	50cc 2T LC	50cc 2T LC	50cc 2T LC	50cc 2T LC
AM 6	EBE050	EBS050	D50B0	D50B0	D50B0	EBS050	D50B0	D50B0	D50B0	AM 6	AM 6
IM07017	IM07040	IM07040	IM07066	IM07066	IM07066	IM07040	IM07066	IM07066	IM07066	IM07017	IM07017
9921720			9930150	9930150	9930150		9930150	9930150	9930150	9921720	9921720
IM07033										IM07033	IM07033
IM07036										IM07036	IM07036
9935000										9935000	9935000
9920020										9920020	9920020
9934440											
99CFAMT10										99CFAMT10	99CFAMT10
99CFAMA10										99CFAMA10	99CFAMA10
CT00746										CT00746	CT00746
9929180	9929190	9929190	9929190	9929190	9929190	9929190	9929190	9929190	9929190	9929180	9929180
9918550										9918550	9918550
9916770 KT00098	9927980 KT00115	9927980 KT00115	9927100	9927100	9927100	9927980 KT00115	9927100	9927100	9927100	9916770 KT00098	9916770 KT00098
9919250 KT00114	9928030	9928030	9927020	9927020	9927020	9928030	9927020	9927020	9927020	9919250 KT00114	9919250 KT00114
9919240										9919240	9919240
9921150										9921150	9921150
9924130										9924130	9924130
9934500										9934500	9934500
9919080										9919080	9919080
9931910										9931910	9931910
9930910	9930910	9930910	9930910	9930910	9930910	9930910	9930910	9930910	9930910	9930910	9930910
9931750	9931750	9931750	9931750	9931750	9931750	9931750	9931750	9931750	9931750	9931750	9931750
99F5MAM10										99F5MAM10	99F5MAM10
9931900										9931900	9931900
9921450										9921450	9921450
9924240			9934270	9934270	9934270		9934270	9934270	9934270	9924240	9924240
9920580	9923180	9923180	9923180	9923180	9923180	9923180	9923180	9923180	9923180	9920580	9920580
										MA00018	
										9924340	9924340
9921180	9923190	9923190	9923190	9923190	9923190	9923190	9923190	9923190	9923190	9921180	9921180
9920250										9920250	9920250
ST00032										ST00032	ST00032
AM00045										AM00045	AM00045
9937820	9937820	9937820	9937820	9937820	9937820	9937820	9937820	9937820	9937820	9937820	9937820

HM	HM	HM	HM
CRE BAJA RR, DERAPAGE RR	CRE BAJA RR, DERAPAGE RR	CRE BAJA, DERAPAGE	CRE BAJA, DERAPAGE
07-09	10-11	07-09	10-11
50cc 2T LC	50cc 2T LC	50cc 2T LC	50cc 2T LC
AM 6	AM 6	AM 6	AM 6



IT	EN	FR				
ALBERO MOTORE standard	Standard Crankshaft	VILEBREQUIN standard		IM07017	IM07017	IM07017
ALBERO MOTORE corsa 39 mm a piattelli pieni	Racing Crankshaft Stroke 39mm	VILEBREQUIN course 39 mm à contre-poids pleins		9921720	9921720	9921720
BIELLA Axe 16	CONROD Axle 16	BIELLE Axe 16		IM07033	IM07033	IM07033
BIELLA Axe 18	CONROD Axle 18	BIELLE Axe 18		IM07036	IM07036	IM07036
CAMBIO COMPLETO RACING	COMPLETE GEAR BOX RACING	BOÎTE DE VITESSES COMPLÈTE RACING		9935000	9935000	9935000
DESMODROMICO CAMBIO	SHIFT DRUM GEAR	BOÎTE DE VITESSES		9920020	9920020	9920020
CENTRALINA AD ANTICIPO FISSO	CDI UNIT WITH VARIABLE ADVANCE (Ducati 6 coils)	BOÎTE ÉLECTRONIQUE numérique à avance variable volant Ducati 6 pôles				
CENTRALINE RACING	RACING EU4 CONTROL UNIT	BOÎTIER ÉLECTRONIQUE RACING EU4				
COPERCHIO FRIZIONE RACING TRASPARENTE	TRANSPARENT CRANKCASE COVER	TRANSPARENT COVER EMBRAYAGE		99CFAMT10	99CFAMT10	99CFAMT10
COPERCHIO FRIZIONE RACING ALLUMINIO	ALUMINIUM CRANKCASE COVER	ALUMINIUM COVER EMBRAYAGE		99CFAMA10	99CFAMA10	99CFAMA10
COLLETTORE ASPIRAZIONE STANDARD	STANDARD INLET MANIFOLD	COLLECTEUR D'ADMISSION STANDARD		CT00746	CT00746	CT00746
CUSCINETTI DI BANCO TPR Carbonitrurati Serie	BEARINGS TPR Carbonitrided	PALIERI DE VILEBREQUIN TPR Carbonitrurés Jeu		9929180	9929180	9929180
FRIZIONE a denti dritti	STRAIGHT TEETH CLUTCH	EMBRAYAGE À DENTS DROITES		9918550	9918550	9918550
GRUPPO TERMICO Ø STD Ghisa	CYLINDER KIT Ø Standard (CAST IRON)	CYLINDRE COMPLET Ø STD Fonte		9916770 KT00098	9916770 KT00098	9916770 KT00098
GRUPPO TERMICO Ø Maggiorato Ghisa	CYLINDER KIT BIG BORE (CAST IRON)	CYLINDRE COMPLET Ø Majoré Fonte		9919250 KT00114	9919250 KT00114	9919250 KT00114
GRUPPO TERMICO RACING Ø 49,5 Ghisa	CYLINDER KIT RACING Ø 49,5 (CAST IRON)	CYLINDRE COMPLET RACING Ø 49,5 Fonte		9919240	9919240	9919240
GRUPPO TERMICO RACING Ø 49,5 Ghisa testa scomposta	CYLINDER KIT RACING Ø 49,5 (CAST IRON) Decomposable head	CYLINDRE COMPLET RACING Ø 49,5 Fonte culasse décomposée		9921150	9921150	9921150
GRUPPO TERMICO RACING Ø 50 alluminio	CYLINDER KIT RACING Ø 50 (ALUMINIUM)	CYLINDRE COMPLET RACING Ø 50 aluminium		9924130	9924130	9924130
GRUPPO TERMICO RACING Ø Standard Alluminio	CYLINDER KIT RACING Ø Standard (ALUMINIUM)	CYLINDRE COMPLET RACING Ø Standard Aluminium		9934500	9934500	9934500
INGRANAGGIO 6 VELOCITA' 1ª serie	GEAR 6° SPEED AM6 1ª SERIES	ENGRENAGE 6 VITESSES 1ª SERIE		9919080	9919080	9919080
INGRANAGGIO 6 VELOCITA' 2ª serie	GEAR 6° SPEED AM6 2ª SERIES	ENGRENAGE 6 VITESSES 2ª SERIE		9931910	9931910	9931910
KIT ASPIRAZIONE COMPLETO TM 24	COMPLETE MIKUNI INLET KIT TM 24 TPR 360	KIT ASPIRATION COMPLET MIKUNI TM 24 TPR 360		9930910	9930910	9930910
KIT ASPIRAZIONE COMPLETO OKO 28	COMPLETE INLET KIT OKO 28 TPR 360	KIT ASPIRATION COMPLET OKO 28 TPR 360		9931750	9931750	9931750
KIT FRIZIONE RACING TPR FACTORY	TPR FACTORY RACING CLUTCH	KIT EMBRAYAGE RACING TPR FACTORY		99F5MAM10	99F5MAM10	99F5MAM10
KIT FRIZIONE + TAMBURO	HOUSING CLUTCH KIT+ BOSS	KIT EMBRAYAGE + TAMBOUR		9931900	9931900	9931900
MAXI KIT RACING 85 cc ghisa Ø 49,5 corsa 44	MAXI KIT RACING 85cc CAST IRON Ø 49,5 stroke 44	MAXI KIT RACING 85 cc fonte Ø 49,5 course 44		9921450	9921450	9921450
MAXI KIT RACING 86 cc alluminio Ø 50 corsa 44	MAXI KIT RACING 86cc ALLUMINIUM Ø 49,5 stroke 44	MAXI KIT RACING 86 cc aluminium Ø 50 course 44		9924240	9924240	9924240
MOLLE FRIZIONE	CLUTCH SPRINGS	RESSORTS EMBRAYAGE		9920580	9920580	9920580
MOTORINO AVVIAMENTO	STARTER ENGINE	DÉMARRÉUR ÉLECTRIQUE		MA00018	MA00018	MA00018
SCARICO RACING omologato	RACING EXHAUST Approved	ÉCHAPPEMENT RACING homologué		9924340	9924340	9924340
SERIE DISCHI frizione racing cellulosa/kevlar	CLUTCH PLATES RACING Cellulose/kevlar	JEU DISQUES embrayage racing cellulose/kevlar		9921180	9921180	9921180
SERIE DISCHI standard	CLUTCH PLATES Standard	JEU DISQUES standard		9920250	9920250	9920250
STATORE	STATOR	STATOR			ST00032	ST00032
VALVOLA LAMELLARE	REED VALVE	CLAPET À LAMELLES		AM00045	AM00045	AM00045
VALVOLA LAMELLARE TPR	REED VALVE TPR	CLAPET À LAMELLES TPR		9937820	9937820	9937820

MALAGUTI	MALAGUTI	MALAGUTI	MALAGUTI
XSM POWER-UP	XSM POWER-UP	XSM POWER-UP	XTM
07-07	08-08	09-10	03-03
50cc 2T LC	50cc 2T LC	50cc 2T LC	50cc 2T LC
AM 6	AM 6	AM 6	AM 6











IT	EN	FR				
ALBERO MOTORE standard	Standard Crankshaft	VILEBREQUIN standard		IM07017	IM07017	IM07017
ALBERO MOTORE corsa 39 mm a piattelli pieni	Racing Crankshaft Stroke 39mm	VILEBREQUIN course 39 mm à contre-poids pleins		9921720	9921720	9921720
BIELLA Axe 16	CONROD Axle 16	BIELLE Axe 16		IM07033	IM07033	IM07033
BIELLA Axe 18	CONROD Axle 18	BIELLE Axe 18		IM07036	IM07036	IM07036
CAMBIO COMPLETO RACING	COMPLETE GEAR BOX RACING	BOÎTE DE VITESSES COMPLÈTE RACING		9935000	9935000	9935000
DESMODROMICO CAMBIO	SHIFT DRUM GEAR	BOÎTE DE VITESSES		9920020	9920020	9920020
CENTRALINA AD ANTICIPO FISSO	CDI UNIT WITH VARIABLE ADVANCE (Ducati 6 coils)	BOÎTE ÉLECTRONIQUE numérique à avance variable volant Ducati 6 pôles				9910150
CENTRALINE RACING	RACING EU4 CONTROL UNIT	BOÎTIER ÉLECTRONIQUE RACING EU4				9921690
COPERCHIO FRIZIONE RACING TRASPARENTE	TRANSPARENT CRANKCASE COVER	TRANSPARENT COVER EMBRAYAGE		99CFAMT10	99CFAMT10	99CFAMT10
COPERCHIO FRIZIONE RACING ALLUMINIO	ALUMINIUM CRANKCASE COVER	ALUMINIUM COVER EMBRAYAGE		99CFAMA10	99CFAMA10	99CFAMA10
COLLETTORE ASPIRAZIONE STANDARD	STANDARD INLET MANIFOLD	COLLECTEUR D'ADMISSION STANDARD		CT00746	CT00746	CT00746
CUSCINETTI DI BANCO TPR Carbonitrurati Serie	BEARINGS TPR Carbonitrided	PALIERI DE VILEBREQUIN TPR Carbonitrurés Jeu		9929180	9929180	9929180
FRIZIONE a denti dritti	STRAIGHT TEETH CLUTCH	EMBRAYAGE À DENTS DROITES		9918550	9918550	9918550
GRUPPO TERMICO Ø STD Ghisa	CYLINDER KIT Ø Standard (CAST IRON)	CYLINDRE COMPLET Ø STD Fonte		9916770 KT00098	9916770 KT00098	9916770 KT00098
GRUPPO TERMICO Ø Maggiorato Ghisa	CYLINDER KIT BIG BORE (CAST IRON)	CYLINDRE COMPLET Ø Majoré Fonte		9919250 KT00114	9919250 KT00114	9919250 KT00114
GRUPPO TERMICO RACING Ø 49,5 Ghisa	CYLINDER KIT RACING Ø 49,5 (CAST IRON)	CYLINDRE COMPLET RACING Ø 49,5 Fonte		9919240	9919240	9919240
GRUPPO TERMICO RACING Ø 49,5 Ghisa testa scomposta	CYLINDER KIT RACING Ø 49,5 (CAST IRON) Decomposable head	CYLINDRE COMPLET RACING Ø 49,5 Fonte culasse décomposée		9921150	9921150	9921150
GRUPPO TERMICO RACING Ø 50 alluminio	CYLINDER KIT RACING Ø 50 (ALUMINIUM)	CYLINDRE COMPLET RACING Ø 50 aluminium		9924130	9924130	9924130
GRUPPO TERMICO RACING Ø Standard Alluminio	CYLINDER KIT RACING Ø Standard (ALUMINIUM)	CYLINDRE COMPLET RACING Ø Standard Aluminium		9934500	9934500	9934500
INGRANAGGIO 6 VELOCITA' 1ª serie	GEAR 6° SPEED AM6 1ª SERIES	ENGRENAGE 6 VITESSES 1ª SERIE		9919080	9919080	9919080
INGRANAGGIO 6 VELOCITA' 2ª serie	GEAR 6° SPEED AM6 2ª SERIES	ENGRENAGE 6 VITESSES 2ª SERIE		9931910	9931910	9931910
KIT ASPIRAZIONE COMPLETO TM 24	COMPLETE MIKUNI INLET KIT TM 24 TPR 360	KIT ASPIRATION COMPLET MIKUNI TM 24 TPR 360		9930910	9930910	9930910
KIT ASPIRAZIONE COMPLETO OKO 28	COMPLETE INLET KIT OKO 28 TPR 360	KIT ASPIRATION COMPLET OKO 28 TPR 360		9931750	9931750	9931750
KIT FRIZIONE RACING TPR FACTORY	TPR FACTORY RACING CLUTCH	KIT EMBRAYAGE RACING TPR FACTORY		99F5MAM10	99F5MAM10	99F5MAM10
KIT FRIZIONE + TAMBURO	HOUSING CLUTCH KIT+ BOSS	KIT EMBRAYAGE + TAMBOUR		9931900	9931900	9931900
MAXI KIT RACING 85 cc ghisa Ø 49,5 corsa 44	MAXI KIT RACING 85cc CAST IRON Ø 49,5 stroke 44	MAXI KIT RACING 85 cc fonte Ø 49,5 course 44		9921450	9921450	9921450
MAXI KIT RACING 86 cc alluminio Ø 50 corsa 44	MAXI KIT RACING 86cc ALLUMINIUM Ø 49,5 stroke 44	MAXI KIT RACING 86 cc aluminium Ø 50 course 44		9924240	9924240	9924240
MOLLE FRIZIONE	CLUTCH SPRINGS	RESSORTS EMBRAYAGE		9920580	9920580	9920580
MOTORINO AVVIAMENTO	STARTER ENGINE	DÉMARREUR ÉLECTRIQUE				
SCARICO RACING omologato	RACING EXHAUST Approved	ÉCHAPPEMENT RACING homologué				
SERIE DISCHI frizione racing cellulosa/kevlar	CLUTCH PLATES RACING Cellulose/kevlar	JEU DISQUES embrayage racing cellulose/kevlar		9921180	9921180	9921180
SERIE DISCHI standard	CLUTCH PLATES Standard	JEU DISQUES standard		9920250	9920250	9920250
STATORE	STATOR	STATOR				
VALVOLA LAMELLARE	REED VALVE	CLAPET À LAMELLES		AM00045	AM00045	AM00045
VALVOLA LAMELLARE TPR	REED VALVE TPR	CLAPET À LAMELLES TPR		9937820	9937820	9937820

MALAGUTI	MALAGUTI	MALAGUTI	MALAGUTI	MALAGUTI	MBK	MBK	MINARELLI	MINARELLI	MINARELLI	MOTORHISPANIA	MOTORHISPANIA
XTM	XTM	XTM POWER-UP	XTM POWER-UP	XTM POWER-UP	X LIMIT	X POWER	MOTORE AM 3-4-5	MOTORE AM 6 1° SERIE	MOTORE AM 6 2° SERIE	FURIA	FURIA MAX
06-06	06-06	07-07	08-08	09-10	03-04	03-04	91-95	96-11	12-18	97-00	10-12
50cc 2T LC	50cc 2T LC	50cc 2T LC	50cc 2T LC	50cc 2T LC	50cc 2T LC	50cc 2T LC	50cc 2T LC	50cc 2T LC	50cc 2T LC	50cc 2T LC	50cc 2T LC
AM 6	AM 6	AM 6	AM 6	AM 6	AM 6	AM 6	AM 3-4-5	AM 6	AM 6	AM 6	AM 6
IM07017	IM07017	IM07017	IM07017	IM07017	IM07017	IM07017	IM07017	IM07017	IM07017	IM07017	IM07017
9921720	9921720	9921720	9921720	9921720	9921720	9921720	9921720	9921720	9921720	9921720	9921720
IM07033	IM07033	IM07033	IM07033	IM07033	IM07033	IM07033	IM07033	IM07033		IM07033	IM07033
IM07036	IM07036	IM07036	IM07036	IM07036	IM07036	IM07036		IM07036	IM07036	IM07036	IM07036
9935000	9935000	9935000	9935000	9935000	9935000	9935000		9935000	9935000	9935000	9935000
9920020	9920020	9920020	9920020	9920020	9920020	9920020		9920020	9920020	9920020	9920020
9910150	9910150				9910150	9910150				9910150	9910150
9921690	9921690				9921690	9921690				9921690	9921690
99CFAMT10	99CFAMT10	99CFAMT10	99CFAMT10	99CFAMT10	99CFAMT10	99CFAMT10	99CFAMT10			99CFAMT10	99CFAMT10
99CFAMA10	99CFAMA10	99CFAMA10	99CFAMA10	99CFAMA10	99CFAMA10	99CFAMA10	99CFAMA10			99CFAMA10	99CFAMA10
CT00746	CT00746	CT00746	CT00746	CT00746	CT00746	CT00746				CT00746	CT00746
9929180	9929180	9929180	9929180	9929180	9929180	9929180	9929180	9929180	9929180	9929180	9929180
9918550	9918550	9918550	9918550	9918550	9918550	9918550	9918550	9918550	9918550	9918550	9918550
9916770 KT00098	9916770 KT00098	9916770 KT00098	9916770 KT00098	9916770 KT00098	9916770 KT00098	9916770 KT00098	9916770 KT00098	9916770 KT00098	9916770 KT00098	9916770 KT00098	9916770 KT00098
9919250 KT00114	9919250 KT00114	9919250 KT00114	9919250 KT00114	9919250 KT00114	9919250 KT00114	9919250 KT00114	9919250 KT00114	9919250 KT00114	9919250 KT00114	9919250 KT00114	9919250 KT00114
9919240	9919240	9919240	9919240	9919240	9919240	9919240	9919240	9919240	9919240	9919240	9919240
9921150	9921150	9921150	9921150	9921150	9921150	9921150	9921150	9921150	9921150	9921150	9921150
9924130	9924130	9924130	9924130	9924130	9924130	9924130	9924130	9924130	9924130	9924130	9924130
9934500	9934500	9934500	9934500	9934500	9934500	9934500	9934500	9934500	9934500	9934500	9934500
9919080	9919080	9919080	9919080	9919080	9919080	9919080		9919080		9919080	9919080
9931910	9931910	9931910	9931910	9931910	9931910	9931910			9931910	9931910	9931910
9930910	9930910	9930910	9930910	9930910	9930910	9930910	9930910	9930910	9930910	9930910	9930910
9931750	9931750	9931750	9931750	9931750	9931750	9931750	9931750	9931750	9931750	9931750	9931750
99F5MAM10	99F5MAM10	99F5MAM10	99F5MAM10	99F5MAM10	99F5MAM10	99F5MAM10	99F5MAM10			99F5MAM10	99F5MAM10
9931900	9931900	9931900	9931900	9931900	9931900	9931900	9931900	9931900	9931900	9931900	9931900
9921450	9921450	9921450	9921450	9921450	9921450	9921450	9921450	9921450	9921450	9921450	9921450
9924240	9924240	9924240	9924240	9924240	9924240	9924240	9924240	9924240	9924240	9924240	9924240
9920580	9920580	9920580	9920580	9920580	9920580	9920580	9920580	9920580	9920580	9920580	9920580
								MA00018	MA00018		
9921180	9921180	9921180	9921180	9921180	9921180	9921180	9921180	9921180	9921180	9921180	9921180
9920250	9920250	9920250	9920250	9920250	9920250	9920250	9920250	9920250	9920250	9920250	9920250
SD00010	SD00010							SD00010	ST00032		ST00032
AM00045	AM00045	AM00045	AM00045	AM00045	AM00045	AM00045	AM00045	AM00045	AM00045	AM00045	AM00045
9937820	9937820	9937820	9937820	9937820	9937820	9937820	9937820	9937820	9937820	9937820	9937820

MOTORHISPANIA	MOTORHISPANIA	PEUGEOT	PEUGEOT
RX	RX R	SUPERMOTARD	XP6 TRAIL S/ AVV. ELET- TRICO
09-12	09-12	90-02	90-02
50cc 2T LC	50cc 2T LC	50cc 2T LC	50cc 2T LC
AM 6	AM 6	AM 6	AM 6







IT	EN	FR					
ALBERO MOTORE standard	Standard Crankshaft	VILEBREQUIN standard		IM07017	IM07017	IM07017	IM07017
ALBERO MOTORE corsa 39 mm a piattelli pieni	Racing Crankshaft Stroke 39mm	VILEBREQUIN course 39 mm à contre-poids pleins		9921720	9921720	9921720	9921720
BIELLA Axe 16	CONROD Axle 16	BIELLE Axe 16		IM07033	IM07033	IM07033	IM07033
BIELLA Axe 18	CONROD Axle 18	BIELLE Axe 18		IM07036	IM07036	IM07036	IM07036
CAMBIO COMPLETO RACING	COMPLETE GEAR BOX RACING	BOÎTE DE VITESSES COMPLÈTE RACING		9935000	9935000	9935000	9935000
DESMODROMICO CAMBIO	SHIFT DRUM GEAR	BOÎTE DE VITESSES		9920020	9920020	9920020	9920020
CENTRALINA AD ANTICIPO FISSO	CDI UNIT WITH VARIABLE ADVANCE (Ducati 6 coils)	BOÎTE ÉLECTRONIQUE numérique à avance variable volant Ducati 6 pôles		9910150	9910150	9910150	9910150
CENTRALINE RACING	RACING EU4 CONTROL UNIT	BOÎTIER ÉLECTRONIQUE RACING EU4		9921690	9921690	9921690	9921690
COPERCHIO FRIZIONE RACING TRASPARENTE	TRANSPARENT CRANKCASE COVER	TRANSPARENT COVER EMBRAYAGE		99CFAMT10	99CFAMT10	99CFAMT10	99CFAMT10
COPERCHIO FRIZIONE RACING ALLUMINIO	ALUMINIUM CRANKCASE COVER	ALUMINIUM COVER EMBRAYAGE		99CFAMA10	99CFAMA10	99CFAMA10	99CFAMA10
COLLETTORE ASPIRAZIONE STANDARD	STANDARD INLET MANIFOLD	COLLECTEUR D'ADMISSION STANDARD		CT00746	CT00746	CT00746	CT00746
CUSCINETTI DI BANCO TPR Carbonitrurati Serie	BEARINGS TPR Carbonitrided	PALIERI DE VILEBREQUIN TPR Carbonitrurés Jeu		9929180	9929180	9929180	9929180
FRIZIONE a denti dritti	STRAIGHT TEETH CLUTCH	EMBRAYAGE À DENTS DROITES		9918550	9918550	9918550	9918550
GRUPPO TERMICO Ø STD Ghisa	CYLINDER KIT Ø Standard (CAST IRON)	CYLINDRE COMPLET Ø STD Fonte		9916770 KT00098	9916770 KT00098	9916770 KT00098	9916770 KT00098
GRUPPO TERMICO Ø Maggiorato Ghisa	CYLINDER KIT BIG BORE (CAST IRON)	CYLINDRE COMPLET Ø Majoré Fonte		9919250 KT00114	9919250 KT00114	9919250 KT00114	9919250 KT00114
GRUPPO TERMICO RACING Ø 49,5 Ghisa	CYLINDER KIT RACING Ø 49,5 (CAST IRON)	CYLINDRE COMPLET RACING Ø 49,5 Fonte		9919240	9919240	9919240	9919240
GRUPPO TERMICO RACING Ø 49,5 Ghisa testa scomposta	CYLINDER KIT RACING Ø 49,5 (CAST IRON) Decomposable head	CYLINDRE COMPLET RACING Ø 49,5 Fonte culasse décomposée		9921150	9921150	9921150	9921150
GRUPPO TERMICO RACING Ø 50 alluminio	CYLINDER KIT RACING Ø 50 (ALUMINIUM)	CYLINDRE COMPLET RACING Ø 50 aluminium		9924130	9924130	9924130	9924130
GRUPPO TERMICO RACING Ø Standard Alluminio	CYLINDER KIT RACING Ø Standard (ALUMINIUM)	CYLINDRE COMPLET RACING Ø Standard Aluminium		9934500	9934500	9934500	9934500
INGRANAGGIO 6 VELOCITA' 1ª serie	GEAR 6° SPEED AM6 1ª SERIES	ENGRENAGE 6 VITESSES 1ª SERIE		9919080	9919080	9919080	9919080
INGRANAGGIO 6 VELOCITA' 2ª serie	GEAR 6° SPEED AM6 2ª SERIES	ENGRENAGE 6 VITESSES 2ª SERIE		9931910	9931910	9931910	9931910
KIT ASPIRAZIONE COMPLETO TM 24	COMPLETE MIKUNI INLET KIT TM 24 TPR 360	KIT ASPIRATION COMPLET MIKUNI TM 24 TPR 360		9930910	9930910	9930910	9930910
KIT ASPIRAZIONE COMPLETO OKO 28	COMPLETE INLET KIT OKO 28 TPR 360	KIT ASPIRATION COMPLET OKO 28 TPR 360		9931750	9931750	9931750	9931750
KIT FRIZIONE RACING TPR FACTORY	TPR FACTORY RACING CLUTCH	KIT EMBRAYAGE RACING TPR FACTORY		99F5MAM10	99F5MAM10	99F5MAM10	99F5MAM10
KIT FRIZIONE + TAMBURO	HOUSING CLUTCH KIT+ BOSS	KIT EMBRAYAGE + TAMBOUR		9931900	9931900	9931900	9931900
MAXI KIT RACING 85 cc ghisa Ø 49,5 corsa 44	MAXI KIT RACING 85cc CAST IRON Ø 49,5 stroke 44	MAXI KIT RACING 85 cc fonte Ø 49,5 course 44		9921450	9921450	9921450	9921450
MAXI KIT RACING 86 cc alluminio Ø 50 corsa 44	MAXI KIT RACING 86cc ALLUMINIUM Ø 49,5 stroke 44	MAXI KIT RACING 86 cc aluminium Ø 50 course 44		9924240	9924240	9924240	9924240
MOLLE FRIZIONE	CLUTCH SPRINGS	RESSORTS EMBRAYAGE		9920580	9920580	9920580	9920580
MOTORINO AVVIAMENTO	STARTER ENGINE	DÉMARREUR ÉLECTRIQUE					
SCARICO RACING omologato	RACING EXHAUST Approved	ÉCHAPPEMENT RACING homologué					
SERIE DISCHI frizione racing cellulosa/kevlar	CLUTCH PLATES RACING Cellulose/kevlar	JEU DISQUES embrayage racing cellulose/kevlar		9921180	9921180	9921180	9921180
SERIE DISCHI standard	CLUTCH PLATES Standard	JEU DISQUES standard		9920250	9920250	9920250	9920250
STATORE	STATOR	STATOR					
VALVOLA LAMELLARE	REED VALVE	CLAPET À LAMELLES		AM00045	AM00045	AM00045	AM00045
VALVOLA LAMELLARE TPR	REED VALVE TPR	CLAPET À LAMELLES TPR		9937820	9937820	9937820	9937820

RIEJU	RIEJU	RIEJU	RIEJU
MRX	MRX PRO	RR	RS1
01-04	01-04	05-06	98-01
50cc 2T LC	50cc 2T LC	50cc 2T LC	50cc 2T LC
AM 6	AM 6	AM 6	AM 6

IT	EN	FR				
ALBERO MOTORE standard	Standard Crankshaft	VILEBREQUIN standard		IM07017	IM07017	IM07017
ALBERO MOTORE corsa 39 mm a piattelli pieni	Racing Crankshaft Stroke 39mm	VILEBREQUIN course 39 mm à contre-poids pleins		9921720	9921720	9921720
BIELLA Axe 16	CONROD Axe 16	BIELLE Axe 16		IM07033	IM07033	IM07033
BIELLA Axe 18	CONROD Axe 18	BIELLE Axe 18		IM07036	IM07036	IM07036
CAMBIO COMPLETO RACING	COMPLETE GEAR BOX RACING	BOÎTE DE VITESSES COMPLÈTE RACING		9935000	9935000	9935000
DESMODROMICO CAMBIO	SHIFT DRUM GEAR	BOÎTE DE VITESSES		9920020	9920020	9920020
CENTRALINA AD ANTICIPO FISSO	CDI UNIT WITH VARIABLE ADVANCE (Ducati 6 coils)	BOÎTE ÉLECTRONIQUE numérique à avance variable volant Ducati 6 pôles		9910150	9910150	9910150
CENTRALINE RACING	RACING EU4 CONTROL UNIT	BOÎTIER ÉLECTRONIQUE RACING EU4		9921690	9921690	9921690
COPERCHIO FRIZIONE RACING TRASPARENTE	TRANSPARENT CRANKCASE COVER	TRANSPARENT COVER EMBRAYAGE		99CFAMT10	99CFAMT10	99CFAMT10
COPERCHIO FRIZIONE RACING ALLUMINIO	ALUMINIUM CRANKCASE COVER	ALUMINIUM COVER EMBRAYAGE		99CFAMA10	99CFAMA10	99CFAMA10
COLLETTORE ASPIRAZIONE STANDARD	STANDARD INLET MANIFOLD	COLLECTEUR D'ADMISSION STANDARD		CT00746	CT00746	CT00746
CUSCINETTI DI BANCO TPR Carbonitrurati Serie	BEARINGS TPR Carbonitrided	PALIERI DE VILEBREQUIN TPR Carbonitrurés Jeu		9929180	9929180	9929180
FRIZIONE a denti dritti	STRAIGHT TEETH CLUTCH	EMBRAYAGE À DENTS DROITES		9918550	9918550	9918550
GRUPPO TERMICO Ø STD Ghisa	CYLINDER KIT Ø Standard (CAST IRON)	CYLINDRE COMPLET Ø STD Fonte		9916770 KT00098	9916770 KT00098	9916770 KT00098
GRUPPO TERMICO Ø Maggioreto Ghisa	CYLINDER KIT BIG BORE (CAST IRON)	CYLINDRE COMPLET Ø Majoré Fonte		9919250 KT00114	9919250 KT00114	9919250 KT00114
GRUPPO TERMICO RACING Ø 49,5 Ghisa	CYLINDER KIT RACING Ø 49,5 (CAST IRON)	CYLINDRE COMPLET RACING Ø 49,5 Fonte		9919240	9919240	9919240
GRUPPO TERMICO RACING Ø 49,5 Ghisa testa scomposta	CYLINDER KIT RACING Ø 49,5 (CAST IRON) Decomposable head	CYLINDRE COMPLET RACING Ø 49,5 Fonte culasse décomposée		9921150	9921150	9921150
GRUPPO TERMICO RACING Ø 50 alluminio	CYLINDER KIT RACING Ø 50 (ALUMINIUM)	CYLINDRE COMPLET RACING Ø 50 aluminium		9924130	9924130	9924130
GRUPPO TERMICO RACING Ø Standard Alluminio	CYLINDER KIT RACING Ø Standard (ALUMINIUM)	CYLINDRE COMPLET RACING Ø Standard Aluminium		9934500	9934500	9934500
INGRANAGGO 6 VELOCITA' 1ª serie	GEAR 6° SPEED AM6 1ª SERIES	ENGRENAGE 6 VITESSES 1ª SERIE		9919080	9919080	9919080
INGRANAGGO 6 VELOCITA' 2ª serie	GEAR 6° SPEED AM6 2ª SERIES	ENGRENAGE 6 VITESSES 2ª SERIE		9931910	9931910	9931910
KIT ASPIRAZIONE COMPLETO TM 24	COMPLETE MIKUNI INLET KIT TM 24 TPR 360	KIT ASPIRATION COMPLET MIKUNI TM 24 TPR 360		9930910	9930910	9930910
KIT ASPIRAZIONE COMPLETO OKO 28	COMPLETE INLET KIT OKO 28 TPR 360	KIT ASPIRATION COMPLET OKO 28 TPR 360		9931750	9931750	9931750
KIT FRIZIONE RACING TPR FACTORY	TPR FACTORY RACING CLUTCH	KIT EMBRAYAGE RACING TPR FACTORY		99F5MAM10	99F5MAM10	99F5MAM10
KIT FRIZIONE + TAMBURO	HOUSING CLUTCH KIT+ BOSS	KIT EMBRAYAGE + TAMBOUR		9931900	9931900	9931900
MAXI KIT RACING 85 cc ghisa Ø 49,5 corsa 44	MAXI KIT RACING 85cc CAST IRON Ø 49,5 stroke 44	MAXI KIT RACING 85 cc fonte Ø 49,5 course 44		9921450	9921450	9921450
MAXI KIT RACING 86 cc alluminio Ø 50 corsa 44	MAXI KIT RACING 86cc ALLUMINIUM Ø 49,5 stroke 44	MAXI KIT RACING 86 cc aluminium Ø 50 course 44		9924240	9924240	9924240
MOLLE FRIZIONE	CLUTCH SPRINGS	RESSORTS EMBRAYAGE		9920580	9920580	9920580
MOTORINO AVVIAMENTO	STARTER ENGINE	DÉMARREUR ÉLECTRIQUE				
SCARICO RACING omologato	RACING EXHAUST Approved	ÉCHAPPEMENT RACING homologué				
SERIE DISCHI frizione racing cellulosa/kevlar	CLUTCH PLATES RACING Cellulose/kevlar	JEU DISQUES embrayage racing cellulose/kevlar		9921180	9921180	9921180
SERIE DISCHI standard	CLUTCH PLATES Standard	JEU DISQUES standard		9920250	9920250	9920250
STATORE	STATOR	STATOR				
VALVOLA LAMELLARE	REED VALVE	CLAPET À LAMELLES		AM00045	AM00045	AM00045
VALVOLA LAMELLARE TPR	REED VALVE TPR	CLAPET À LAMELLES TPR		9937820	9937820	9937820











RIEJU	RIEJU	RIEJU	RIEJU	RIEJU	RIEJU	RIEJU	RIEJU	RIEJU	SHERCO	SHERCO	SHERCO
RS2 MATRIX	RS2 MATRIX PRO	RS2 NAKED	RS3	RS3 EU4	RS3 NKD EU4	SMX E.S./K.S.	SMX PRO E.S./K.S.	SPIKE	FACTORY SE-R EU4	FACTORY SE-RS EU4	FACTORY SILVER SM-R EU4
05-06	05-06	04-05	11-11	18-20	18-20	01-01	03-03	98-01	18-20	18-20	18-20
50cc 2T LC	50cc 2T LC	50cc 2T LC	50cc 2T LC	50cc 2T LC	50cc 2T LC	50cc 2T LC	50cc 2T LC	50cc 2T LC	50cc 2T LC	50cc 2T LC	50cc 2T LC
AM 6	AM 6	AM 6	AM 6	AM 6	AM 6	AM 6	AM 6	AM 6	AM 6	AM 6	AM 6
IM07017	IM07017	IM07017		IM07017	IM07017	IM07017	IM07017	IM07017	IM07017	IM07017	IM07017
9921720	9921720	9921720		9921720	9921720	9921720	9921720	9921720	9921720	9921720	9921720
IM07033	IM07033	IM07033		IM07033	IM07033	IM07033	IM07033	IM07033	IM07033	IM07033	IM07033
IM07036	IM07036	IM07036		IM07036	IM07036	IM07036	IM07036	IM07036	IM07036	IM07036	IM07036
9935000	9935000	9935000		9935000	9935000	9935000	9935000	9935000	9935000	9935000	9935000
9920020	9920020	9920020		9920020	9920020	9920020	9920020	9920020	9920020	9920020	9920020
9910150	9910150	9910150				9910150	9910150	9910150			
9921690	9921690	9921690		9934440	9934440	9921690	9921690	9921690	9934440	9934440	9934440
99CFAMT10	99CFAMT10	99CFAMT10		99CFAMT10	99CFAMT10	99CFAMT10	99CFAMT10	99CFAMT10	99CFAMT10	99CFAMT10	99CFAMT10
99CFAMA10	99CFAMA10	99CFAMA10		99CFAMA10	99CFAMA10	99CFAMA10	99CFAMA10	99CFAMA10	99CFAMA10	99CFAMA10	99CFAMA10
CT00746	CT00746	CT00746		CT00746	CT00746	CT00746	CT00746	CT00746	CT00746	CT00746	CT00746
9929180	9929180	9929180		9929180	9929180	9929180	9929180	9929180	9929180	9929180	9929180
9918550	9918550	9918550		9918550	9918550	9918550	9918550	9918550	9918550	9918550	9918550
9916770 KT00098	9916770 KT00098	9916770 KT00098		9916770 KT00098	9916770 KT00098	9916770 KT00098	9916770 KT00098	9916770 KT00098	9916770 KT00098	9916770 KT00098	9916770 KT00098
9919250 KT00114	9919250 KT00114	9919250 KT00114		9919250 KT00114	9919250 KT00114	9919250 KT00114	9919250 KT00114	9919250 KT00114	9919250 KT00114	9919250 KT00114	9919250 KT00114
9919240	9919240	9919240		9919240	9919240	9919240	9919240	9919240	9919240	9919240	9919240
9921150	9921150	9921150		9921150	9921150	9921150	9921150	9921150	9921150	9921150	9921150
9924130	9924130	9924130		9924130	9924130	9924130	9924130	9924130	9924130	9924130	9924130
9934500	9934500	9934500		9934500	9934500	9934500	9934500	9934500	9934500	9934500	9934500
9919080	9919080	9919080		9919080	9919080	9919080	9919080	9919080	9919080	9919080	9919080
9931910	9931910	9931910		9931910	9931910	9931910	9931910	9931910	9931910	9931910	9931910
9930910	9930910	9930910		9930910	9930910	9930910	9930910	9930910	9930910	9930910	9930910
9931750	9931750	9931750		9931750	9931750	9931750	9931750	9931750	9931750	9931750	9931750
99F5MAM10	99F5MAM10	99F5MAM10		99F5MAM10	99F5MAM10	99F5MAM10	99F5MAM10	99F5MAM10	99F5MAM10	99F5MAM10	99F5MAM10
9931900	9931900	9931900		9931900	9931900	9931900	9931900	9931900	9931900	9931900	9931900
9921450	9921450	9921450		9921450	9921450	9921450	9921450	9921450	9921450	9921450	9921450
9924240	9924240	9924240		9924240	9924240	9924240	9924240	9924240	9924240	9924240	9924240
9920580	9920580	9920580		9920580	9920580	9920580	9920580	9920580	9920580	9920580	9920580
9921180	9921180	9921180		9921180	9921180	9921180	9921180	9921180	9921180	9921180	9921180
9920250	9920250	9920250		9920250	9920250	9920250	9920250	9920250	9920250	9920250	9920250
			ST00032	ST00032	ST00032				ST00032	ST00032	ST00032
AM00045	AM00045	AM00045		AM00045	AM00045	AM00045	AM00045	AM00045	AM00045	AM00045	AM00045
9937820	9937820	9937820		9937820	9937820	9937820	9937820	9937820	9937820	9937820	9937820

SHERCO	SHERCO	SHERCO	SHERCO
FACTORY SILVER SM-RS EU4	FACTORY SM-R EU4	FACTORY SM-RS EU4	HRD ENDURO
18-20	18-20	18-20	09-13
50cc 2T LC	50cc 2T LC	50cc 2T LC	50cc 2T LC
AM 6	AM 6	AM 6	AM 6

IT	EN	FR				
ALBERO MOTORE standard	Standard Crankshaft	VILEBREQUIN standard		IM07017	IM07017	IM07017
ALBERO MOTORE corsa 39 mm a piattelli pieni	Racing Crankshaft Stroke 39mm	VILEBREQUIN course 39 mm à contre-poids pleins		9921720	9921720	9921720
BIELLA Axe 16	CONROD Axle 16	BIELLE Axe 16		IM07033	IM07033	IM07033
BIELLA Axe 18	CONROD Axle 18	BIELLE Axe 18		IM07036	IM07036	IM07036
CAMBIO COMPLETO RACING	COMPLETE GEAR BOX RACING	BOÎTE DE VITESSES COMPLÈTE RACING		9935000	9935000	9935000
DESMODROMICO CAMBIO	SHIFT DRUM GEAR	BOÎTE DE VITESSES		9920020	9920020	9920020
CENTRALINA AD ANTICIPO FISSO	CDI UNIT WITH VARIABLE ADVANCE (Ducati 6 coils)	BOÎTE ÉLECTRONIQUE numérique à avance variable volant Ducati 6 pôles				9910150
CENTRALINE RACING	RACING EU4 CONTROL UNIT	BOÎTIER ÉLECTRONIQUE RACING EU4		9934440	9934440	9934440
COPERCHIO FRIZIONE RACING TRASPARENTE	TRANSPARENT CRANKCASE COVER	TRANSPARENT COVER EMBRAYAGE		99CFAMT10	99CFAMT10	99CFAMT10
COPERCHIO FRIZIONE RACING ALLUMINIO	ALUMINIUM CRANKCASE COVER	ALUMINIUM COVER EMBRAYAGE		99CFAMA10	99CFAMA10	99CFAMA10
COLLETTORE ASPIRAZIONE STANDARD	STANDARD INLET MANIFOLD	COLLECTEUR D'ADMISSION STANDARD		CT00746	CT00746	CT00746
CUSCINETTI DI BANCO TPR Carbonitrurati Serie	BEARINGS TPR Carbonitrided	PALIERI DE VILEBREQUIN TPR Carbonitrurés Jeu		9929180	9929180	9929180
FRIZIONE a denti dritti	STRAIGHT TEETH CLUTCH	EMBRAYAGE À DENTS DROITES		9918550	9918550	9918550
GRUPPO TERMICO Ø STD Ghisa	CYLINDER KIT Ø Standard (CAST IRON)	CYLINDRE COMPLET Ø STD Fonte		9916770 KT00098	9916770 KT00098	9916770 KT00098
GRUPPO TERMICO Ø Maggiorato Ghisa	CYLINDER KIT BIG BORE (CAST IRON)	CYLINDRE COMPLET Ø Majoré Fonte		9919250 KT00114	9919250 KT00114	9919250 KT00114
GRUPPO TERMICO RACING Ø 49,5 Ghisa	CYLINDER KIT RACING Ø 49,5 (CAST IRON)	CYLINDRE COMPLET RACING Ø 49,5 Fonte		9919240	9919240	9919240
GRUPPO TERMICO RACING Ø 49,5 Ghisa testa scomposta	CYLINDER KIT RACING Ø 49,5 (CAST IRON) Decomposable head	CYLINDRE COMPLET RACING Ø 49,5 Fonte culasse décomposée		9921150	9921150	9921150
GRUPPO TERMICO RACING Ø 50 alluminio	CYLINDER KIT RACING Ø 50 (ALUMINIUM)	CYLINDRE COMPLET RACING Ø 50 aluminium		9924130	9924130	9924130
GRUPPO TERMICO RACING Ø Standard Alluminio	CYLINDER KIT RACING Ø Standard (ALUMINIUM)	CYLINDRE COMPLET RACING Ø Standard Aluminium		9934500	9934500	9934500
INGRANAGGIO 6 VELOCITA' 1ª serie	GEAR 6° SPEED AM6 1ª SERIES	ENGRENAGE 6 VITESSES 1ª SERIE		9919080	9919080	9919080
INGRANAGGIO 6 VELOCITA' 2ª serie	GEAR 6° SPEED AM6 2ª SERIES	ENGRENAGE 6 VITESSES 2ª SERIE		9931910	9931910	9931910
KIT ASPIRAZIONE COMPLETO TM 24	COMPLETE MIKUNI INLET KIT TM 24 TPR 360	KIT ASPIRATION COMPLET MIKUNI TM 24 TPR 360		9930910	9930910	9930910
KIT ASPIRAZIONE COMPLETO OKO 28	COMPLETE INLET KIT OKO 28 TPR 360	KIT ASPIRATION COMPLET OKO 28 TPR 360		9931750	9931750	9931750
KIT FRIZIONE RACING TPR FACTORY	TPR FACTORY RACING CLUTCH	KIT EMBRAYAGE RACING TPR FACTORY		99F5MAM10	99F5MAM10	99F5MAM10
KIT FRIZIONE + TAMBURO	HOUSING CLUTCH KIT+ BOSS	KIT EMBRAYAGE + TAMBOUR		9931900	9931900	9931900
MAXI KIT RACING 85 cc ghisa Ø 49,5 corsa 44	MAXI KIT RACING 85cc CAST IRON Ø 49,5 stroke 44	MAXI KIT RACING 85 cc fonte Ø 49,5 course 44		9921450	9921450	9921450
MAXI KIT RACING 86 cc alluminio Ø 50 corsa 44	MAXI KIT RACING 86cc ALLUMINIUM Ø 49,5 stroke 44	MAXI KIT RACING 86 cc aluminium Ø 50 course 44		9924240	9924240	9924240
MOLLE FRIZIONE	CLUTCH SPRINGS	RESSORTS EMBRAYAGE		9920580	9920580	9920580
MOTORINO AVVIAMENTO	STARTER ENGINE	DÉMARREUR ÉLECTRIQUE				
SCARICO RACING omologato	RACING EXHAUST Approved	ÉCHAPPEMENT RACING homologué				
SERIE DISCHI frizione racing cellulosa/kevlar	CLUTCH PLATES RACING Cellulose/kevlar	JEU DISQUES embrayage racing cellulose/kevlar		9921180	9921180	9921180
SERIE DISCHI standard	CLUTCH PLATES Standard	JEU DISQUES standard		9920250	9920250	9920250
STATORE	STATOR	STATOR		ST00032	ST00032	ST00032
VALVOLA LAMELLARE	REED VALVE	CLAPET À LAMELLES		AM00045	AM00045	AM00045
VALVOLA LAMELLARE TPR	REED VALVE TPR	CLAPET À LAMELLES TPR		9937820	9937820	9937820

SHERCO	VALENTI RACING	VALENTI RACING	VENT	VENT	VENT	VENT	YAMAHA	YAMAHA	YAMAHA	YAMAHA	YAMAHA
HRD MOTARD	RME	SM	BAJA	BAJA RR	DERAPAGE	DERAPAGE RR	DT R	DT R	DT R	DT R	DT RSM
09-13	15-17	15-17	18-20	18-20	18-20	18-20	03-05	06-06	07-07	08-11	03-05
50cc 2T LC	50cc 2T LC	50cc 2T LC	50cc 2T LC	50cc 2T LC	50cc 2T LC	50cc 2T LC	50cc 2T LC	50cc 2T LC	50cc 2T LC	50cc 2T LC	50cc 2T LC
AM 6	D50B0	D50B0	AM 6	AM 6	AM 6	AM 6	AM 6	AM 6	AM 6	AM 6	AM 6
IM07017	IM07066	IM07066	IM07017	IM07017	IM07017	IM07017	IM07017	IM07017	IM07017	IM07017	IM07017
9921720	9930150	9930150	9921720	9921720	9921720	9921720	9921720	9921720	9921720	9921720	9921720
IM07033							IM07033	IM07033	IM07033	IM07033	IM07033
IM07036			IM07036	IM07036	IM07036	IM07036	IM07036	IM07036	IM07036	IM07036	IM07036
9935000			9935000	9935000	9935000	9935000	9935000	9935000	9935000	9935000	9935000
9920020			9920020	9920020	9920020	9920020	9920020	9920020	9920020	9920020	9920020
9910150							9910150	9910150			9910150
9921690			9934440	9934440	9934440	9934440	9921690	9921690			9921690
99CFAMT10							99CFAMT10	99CFAMT10	99CFAMT10	99CFAMT10	99CFAMT10
99CFAMA10							99CFAMA10	99CFAMA10	99CFAMA10	99CFAMA10	99CFAMA10
CT00746			CT00746	CT00746	CT00746	CT00746	CT00746	CT00746	CT00746	CT00746	CT00746
9929180	9929190	9929190	9929180	9929180	9929180	9929180	9929180	9929180	9929180	9929180	9929180
9918550			9918550	9918550	9918550	9918550	9918550	9918550	9918550	9918550	9918550
9916770 KT00098	9927100	9927100	9916770 KT00098	9916770 KT00098	9916770 KT00098	9916770 KT00098	9916770 KT00098	9916770 KT00098	9916770 KT00098	9916770 KT00098	9916770 KT00098
9919250 KT00114	9927020	9927020	9919250 KT00114	9919250 KT00114	9919250 KT00114	9919250 KT00114	9919250 KT00114	9919250 KT00114	9919250 KT00114	9919250 KT00114	9919250 KT00114
9919240			9919240	9919240	9919240	9919240	9919240	9919240	9919240	9919240	9919240
9921150			9921150	9921150	9921150	9921150	9921150	9921150	9921150	9921150	9921150
9924130			9924130	9924130	9924130	9924130	9924130	9924130	9924130	9924130	9924130
9934500			9934500	9934500	9934500	9934500	9934500	9934500	9934500	9934500	9934500
9919080							9919080	9919080	9919080	9919080	9919080
9931910			9931910	9931910	9931910	9931910	9931910	9931910	9931910	9931910	9931910
9930910	9930910	9930910	9930910	9930910	9930910	9930910	9930910	9930910	9930910	9930910	9930910
9931750	9931750	9931750	9931750	9931750	9931750	9931750	9931750	9931750	9931750	9931750	9931750
99F5MAM10							99F5MAM10	99F5MAM10	99F5MAM10	99F5MAM10	99F5MAM10
9931900			9931900	9931900	9931900	9931900	9931900	9931900	9931900	9931900	9931900
9921450			9921450	9921450	9921450	9921450	9921450	9921450	9921450	9921450	9921450
9924240	9934270	9934270	9924240	9924240	9924240	9924240	9924240	9924240	9924240	9924240	9924240
9920580	9923180	9923180	9920580	9920580	9920580	9920580	9920580	9920580	9920580	9920580	9920580
			MA00018	MA00018	MA00018	MA00018					
			9924340	9924340	9924340	9924340					
9921180	9923190	9923190	9921180	9921180	9921180	9921180	9921180	9921180	9921180	9921180	9921180
9920250			9920250	9920250	9920250	9920250	9920250	9920250	9920250	9920250	9920250
			ST00032	ST00032	ST00032	ST00032					
AM00045							AM00045	AM00045	AM00045	AM00045	AM00045
9937820	9937820	9937820	9937820	9937820	9937820	9937820	9937820	9937820	9937820	9937820	9937820

YAMAHA	YAMAHA	YAMAHA	YAMAHA
DT X	DT X	DT X	TZR
06-06	07-07	08-11	03-05
50cc 2T LC	50cc 2T LC	50cc 2T LC	50cc 2T LC
AM 6	AM 6	AM 6	AM 6

IT	EN	FR					
ALBERO MOTORE standard	Standard Crankshaft	VILEBREQUIN standard		IM07017	IM07017	IM07017	IM07017
ALBERO MOTORE corsa 39 mm a piatti pieni	Racing Crankshaft Stroke 39mm	VILEBREQUIN course 39 mm à contre-poids pleins		9921720	9921720	9921720	9921720
BIELLA Axe 16	CONROD Axle 16	BIELLE Axe 16		IM07033	IM07033	IM07033	IM07033
BIELLA Axe 18	CONROD Axle 18	BIELLE Axe 18		IM07036	IM07036	IM07036	IM07036
CAMBIO COMPLETO RACING	COMPLETE GEAR BOX RACING	BOÎTE DE VITESSES COMPLÈTE RACING		9935000	9935000	9935000	9935000
DESMODROMICO CAMBIO	SHIFT DRUM GEAR	BOÎTE DE VITESSES		9920020	9920020	9920020	9920020
CENTRALINA AD ANTICIPO FISSO	CDI UNIT WITH VARIABLE ADVANCE (Ducati 6 coils)	BOÎTE ÉLECTRONIQUE numérique à avance variable volant Ducati 6 pôles		9910150			
CENTRALINE RACING	RACING EU4 CONTROL UNIT	BOÎTIER ÉLECTRONIQUE RACING EU4		9921690			
COPERCHIO FRIZIONE RACING TRASPARENTE	TRANSPARENT CRANKCASE COVER	TRANSPARENT COVER EMBRAYAGE		99CFAMT10	99CFAMT10	99CFAMT10	99CFAMT10
COPERCHIO FRIZIONE RACING ALLUMINIO	ALUMINIUM CRANKCASE COVER	ALUMINIUM COVER EMBRAYAGE		99CFAMA10	99CFAMA10	99CFAMA10	99CFAMA10
COLLETTORE ASPIRAZIONE STANDARD	STANDARD INLET MANIFOLD	COLLECTEUR D'ADMISSION STANDARD		CT00746	CT00746	CT00746	CT00746
CUSCINETTI DI BANCO TPR Carbonitrurati Serie	BEARINGS TPR Carbonitrided	PALIERI DE VILEBREQUIN TPR Carbonitrurés Jeu		9929180	9929180	9929180	9929180
FRIZIONE a denti dritti	STRAIGHT TEETH CLUTCH	EMBRAYAGE À DENTS DROITES		9918550	9918550	9918550	9918550
GRUPPO TERMICO Ø STD Ghisa	CYLINDER KIT Ø Standard (CAST IRON)	CYLINDRE COMPLET Ø STD Fonte		9916770 KT00098	9916770 KT00098	9916770 KT00098	9916770 KT00098
GRUPPO TERMICO Ø Maggioreto Ghisa	CYLINDER KIT BIG BORE (CAST IRON)	CYLINDRE COMPLET Ø Majoré Fonte		9919250 KT00114	9919250 KT00114	9919250 KT00114	9919250 KT00114
GRUPPO TERMICO RACING Ø 49,5 Ghisa	CYLINDER KIT RACING Ø 49,5 (CAST IRON)	CYLINDRE COMPLET RACING Ø 49,5 Fonte		9919240	9919240	9919240	9919240
GRUPPO TERMICO RACING Ø 49,5 Ghisa testa scomposta	CYLINDER KIT RACING Ø 49,5 (CAST IRON) Decomposable head	CYLINDRE COMPLET RACING Ø 49,5 Fonte culasse décomposée		9921150	9921150	9921150	9921150
GRUPPO TERMICO RACING Ø 50 alluminio	CYLINDER KIT RACING Ø 50 (ALUMINIUM)	CYLINDRE COMPLET RACING Ø 50 aluminium		9924130	9924130	9924130	9924130
GRUPPO TERMICO RACING Ø Standard Alluminio	CYLINDER KIT RACING Ø Standard (ALUMINIUM)	CYLINDRE COMPLET RACING Ø Standard Aluminium		9934500	9934500	9934500	9934500
INGRANAGGO 6 VELOCITA' 1ª serie	GEAR 6° SPEED AM6 1ª SERIES	ENGRENAGE 6 VITESSES 1ª SERIE		9919080	9919080	9919080	9919080
INGRANAGGO 6 VELOCITA' 2ª serie	GEAR 6° SPEED AM6 2ª SERIES	ENGRENAGE 6 VITESSES 2ª SERIE		9931910	9931910	9931910	9931910
KIT ASPIRAZIONE COMPLETO TM 24	COMPLETE MIKUNI INLET KIT TM 24 TPR 360	KIT ASPIRATION COMPLET MIKUNI TM 24 TPR 360		9930910	9930910	9930910	9930910
KIT ASPIRAZIONE COMPLETO OKO 28	COMPLETE INLET KIT OKO 28 TPR 360	KIT ASPIRATION COMPLET OKO 28 TPR 360		9931750	9931750	9931750	9931750
KIT FRIZIONE RACING TPR FACTORY	TPR FACTORY RACING CLUTCH	KIT EMBRAYAGE RACING TPR FACTORY		99F5MAM10	99F5MAM10	99F5MAM10	99F5MAM10
KIT FRIZIONE + TAMBURO	HOUSING CLUTCH KIT+ BOSS	KIT EMBRAYAGE + TAMBOUR		9931900	9931900	9931900	9931900
MAXI KIT RACING 85 cc ghisa Ø 49,5 corsa 44	MAXI KIT RACING 85cc CAST IRON Ø 49,5 stroke 44	MAXI KIT RACING 85 cc fonte Ø 49,5 course 44		9921450	9921450	9921450	9921450
MAXI KIT RACING 86 cc alluminio Ø 50 corsa 44	MAXI KIT RACING 86cc ALLUMINIUM Ø 49,5 stroke 44	MAXI KIT RACING 86 cc aluminium Ø 50 course 44		9924240	9924240	9924240	9924240
MOLLE FRIZIONE	CLUTCH SPRINGS	RESSORTS EMBRAYAGE		9920580	9920580	9920580	9920580
MOTORINO AVVIAMENTO	STARTER ENGINE	DÉMARREUR ÉLECTRIQUE					MA00018
SCARICO RACING omologato	RACING EXHAUST Approved	ÉCHAPPEMENT RACING homologué					
SERIE DISCHI frizione racing cellulosa/kevlar	CLUTCH PLATES RACING Cellulose/kevlar	JEU DISQUES embrayage racing cellulose/kevlar		9921180	9921180	9921180	9921180
SERIE DISCHI standard	CLUTCH PLATES Standard	JEU DISQUES standard		9920250	9920250	9920250	9920250
STATORE	STATOR	STATOR					
VALVOLA LAMELLARE	REED VALVE	CLAPET À LAMELLES		AM00045	AM00045	AM00045	AM00045
VALVOLA LAMELLARE TPR	REED VALVE TPR	CLAPET À LAMELLES TPR		9937820	9937820	9937820	9937820

YAMAHA	YAMAHA	YAMAHA	YAMAHA	YAMAHA	YAMAHA
TZR	TZR	TZR	TZR	TZR	TZR RR
06-06	07-07	08-08	10-10	11-11	05-05
50cc 2T LC	50cc 2T LC	50cc 2T LC	50cc 2T LC	50cc 2T LC	50cc 2T LC
AM 6	AM 6	AM 6	AM 6	AM 6	AM 6
IM07017	IM07017	IM07017	IM07017	IM07017	IM07017
9921720	9921720	9921720	9921720	9921720	9921720
IM07033	IM07033	IM07033	IM07033	IM07033	IM07033
IM07036	IM07036	IM07036	IM07036	IM07036	IM07036
9935000	9935000	9935000	9935000		9935000
9920020	9920020	9920020	9920020	9920020	9920020
99CFAMT10	99CFAMT10	99CFAMT10	99CFAMT10	99CFAMT10	99CFAMT10
99CFAMA10	99CFAMA10	99CFAMA10	99CFAMA10	99CFAMA10	99CFAMA10
CT00746	CT00746	CT00746	CT00746	CT00746	CT00746
9929180	9929180	9929180	9929180	9929180	9929180
9918550	9918550	9918550	9918550	9918550	9918550
9916770 KT00098	9916770 KT00098	9916770 KT00098	9916770 KT00098	9916770 KT00098	9916770 KT00098
9919250 KT00114	9919250 KT00114	9919250 KT00114	9919250 KT00114	9919250 KT00114	9919250 KT00114
9919240	9919240	9919240	9919240	9919240	9919240
9921150	9921150	9921150	9921150	9921150	9921150
9924130	9924130	9924130	9924130	9924130	9924130
9934500	9934500	9934500	9934500	9934500	9934500
9919080	9919080	9919080	9919080		9919080
9931910	9931910	9931910	9931910		9931910
9930910	9930910	9930910	9930910	9930910	9930910
9931750	9931750	9931750	9931750	9931750	9931750
99F5MAM10	99F5MAM10	99F5MAM10	99F5MAM10	99F5MAM10	99F5MAM10
9931900	9931900	9931900	9931900	9931900	9931900
9921450	9921450	9921450	9921450	9921450	9921450
9924240	9924240	9924240	9924240	9924240	9924240
9920580	9920580	9920580	9920580	9920580	9920580
MA00018	MA00018	MA00018	MA00018	MA00018	MA00018
9921180	9921180	9921180	9921180	9921180	9921180
9920250	9920250	9920250	9920250	9920250	9920250
AM00045	AM00045	AM00045	AM00045	AM00045	AM00045
9937820	9937820	9937820	9937820	9937820	9937820



MOTO 50cc

SCOOTER 50cc

TOP
- performances -



APRILIA APRILIA APRILIA APRILIA

AMICO AMICO AMICO GL/GLE AMICO LX/SPORT/CAT

94-94 96-98 93-95 92-93

50cc 2T AC 50cc 2T AC 50cc 2T AC 50cc 2T

CW CW CW CW

IT	EN	FR					
ALBERO MESSA IN MOTO	KICK SHAFT	ARBRE DE DEMARREUR		CI07487	CI07487	CI07487	
ALBERO MOTORE Con Cuscinetti e Paraoli	CRANKSHAFT with bearings and oil seals	VILEBREQUIN doté de Paliers et Joints d'huile		IM07058	IM07058	IM07058	
ALBERO MOTORE Senza Cuscinetti e Paraoli	CRANKSHAFT without bearings and oil seals	VILEBREQUIN sans Paliers et Joints d'huile		IM07013	IM07013	IM07013	
BIELLA	CONROD	BIELLE		IM07032	IM07032	IM07032	
CAMPANA FRIZIONE	CLUTCH HOUSING	CLOCHE EMBRAYAGE					
CENTRALINA AD ANTICIPO FISSO	DIGITAL IGNITION UNIT	ALLUMAGE Fixe					
CENTRALINA AD ANTICIPO VARIABILE 4T	IGNITION UNIT Variable	ALLUMAGE Numérique					
CINGHIA DI TRASMISSIONE TOP	TRANSMISSION BELT TOP PERFORMANCES	COURROIE DE TRANSMISSION TOP PERFORMANCES		9907770	9907770	9907770	
CINGHIA DI TRASMISSIONE Mitsubishi	TRANSMISSION BELT Mitsubishi	COURROIE DE TRANSMISSION Mitsubishi		9935270	9935270	9935270	
COLLETTORE ASPIRAZIONE	INLET MANIFOLD	COLLECTEUR ASPIRATION		CT00726	CT00726	CT00726	
FRIZIONE CENTRIFUGA Interno Ø 105	CENTRIFUGAL CLUTCH Ø 105	EMBAYAGE CENTRIFUGE Ø 105		9911060	9911060	9911060	
FRIZIONE CENTRIFUGA Interno Ø 107	CENTRIFUGAL CLUTCH Ø 107	EMBAYAGE CENTRIFUGE Ø 107		9910020 9925130	9910020 9925130	9910020 9925130	
GANASCE FRENO	BRAKE SHOES	MÂCHOIRES FREIN					CP00219
GRUPPO TERMICO Ø Standard c/testa	CYLINDER KIT Ø standard with head	CYLINDRE COMPLET Ø Standard avec culasse		9931170	9931170	9931170	
GRUPPO TERMICO Ø Standard s/testa	CYLINDER KIT Ø standard without head	CYLINDRE COMPLET Ø Standard sans culasse		KT00096	KT00096	KT00096	
GRUPPO TERMICO Ø Magg. c/testa	CYLINDER KIT BIG BORE with head	CYLINDRE COMPLET Ø Majoré avec culasse		9931370 KT00088	9931370 KT00088	9931370 KT00088	
GRUPPO TERMICO Ø Magg. s/testa	CYLINDER KIT BIG BORE without head	CYLINDRE COMPLET Ø Majoré sans culasse					
GRUPPO TERMICO Modifica da AC a LC	CYLINDER KIT Conversion AC to LC	CYLINDRE COMPLET Modification de AC à LC					
KIT CUSCINETTI DA BANCO	BEARINGS KIT	KIT PALIERS DE VILEBREQUIN		KK01000 KK01002	KK01000 KK01002	KK01000 KK01002	
KIT REVISIONE POMPA ACQUA	WATER PUMP REPAIR KIT	KIT RÉVISION POMPE À EAU					
MEMBRANA CARBURATORE	CARBURETOR DIAPHRAGM	MEMBRANE CARBURATEUR					
MOTORINO D'AVVIAMENTO	STARTER ENGINE	DÉMARREUR ÉLECTRIQUE		MA00001	MA00001	MA00001	
PULEGGIA FISSA	VARIATOR SHEAVE FIXED	POULIE FIXE					
RAPPORTI ALLUNGATI Primari	GÉARS KIT Primary	RAPPORTS ALLONGÉS Primaires		9913300	9913300	9913300	
RAPPORTI ALLUNGATI Secondari	GÉARS KIT Secondary	RAPPORTS ALLONGÉS Secondaires					
REGOLATORE DI TENSIONE	RECTIFIER	RÉGULATEUR DE TENSION		RE00014	RE00014	RE00014	
RUOTA LIBERA	STARTER CLUTCH	ROUE LIBRE		AA00767 RL00001	AA00767 RL00001	AA00767 RL00001	
STATORE	STATOR	STATOR					
VALVOLE LAMELLARI	REED VALVE	CLAPET À LAMELLES		9906520	9906520	9906520	

APRILIA	APRILIA	APRILIA	APRILIA	APRILIA	APRILIA	APRILIA	APRILIA	APRILIA	APRILIA	APRILIA	APRILIA
AMICO LX/ SPORT/CAT	AREA 51	GULLIVER	GULLIVER LC	GULLIVER LC	HABANA- MOJITO CUSTOM	HABANA- MOJITO RETRO'	MOJITO CUSTOM 2T MOTORE PIAGGIO	RALLY	RALLY LIQUID COOLED	SCARABEO	SCARABEO
92-93	98-00	95-98	96-98	96-98	99-03	99-03	04-10	95-03	96-99	93-97	98-98
50cc 2T AC	50cc 2T LC	50cc 2T AC	50cc 2T	50cc 2T LC	50cc 2T AC	50cc 2T AC	50cc 2T AC	50cc 2T AC	50cc 2T LC	50cc 2T AC	50cc 2T AC
CW	MA	MY	MA	MA	Motore Aprilia	Motore Aprilia	Motore Piaggio	MY	MA	MY	MY
CI07487	CI07487	CI07487		CI07487			CI07494	CI07487	CI07487	CI07487	CI07487
IM07058	IM07059	IM07059		IM07059			IM07060	IM07059	IM07059	IM07059	IM07059
IM07013	IM07014	IM07014		IM07014			IM07015	IM07014	IM07014	IM07014	IM07014
IM07032	IM07032	IM07032		IM07032			IM07031	IM07032	IM07032	IM07032	IM07032
	9924940	9924940		9924940			9924950	9924940	9924940	9924940	9924940
	9910100	9910100		9910100				9910100	9910100	9910100	9910100
9907770	9907770	9907770		9907770	9920440	9920440	9922030	9907770	9907770	9907770	9907770
9935270	9935270	9935270		9935270	9935820	9935820	9935830	9935270	9935270	9935270	9935270
CT00726	CT00725	CT00725		CT00725			CT00727	CT00725	CT00725	CT00725	CT00725
9911060	9911060	9911060		9911060				9911060	9911060	9911060	9911060
9910020 9925130	9910020 9925130	9910020 9925130		9910020 9925130			9910020	9910020 9925130	9910020 9925130	9910020 9925130	9910020 9925130
			CP00219								
9931170	9931110	9931140		9931110			9914500	9931140	9931110	9931140	9931140
KT00096	KT00094	KT00095		KT00094			KT00080	KT00095	KT00094	KT00095	KT00095
9931370 KT00088	9931310 KT00109	9931340 KT00087		9931310 KT00109			9931250 KT00086	9931340 KT00087	9931310 KT00109	9931340 KT00087	9931340 KT00087
					KT00057	KT00057					
		9911090						9911090		9911090	9911090
KK01000 KK01002	KK01000 KK01002	KK01000 KK01002		KK01000 KK01002			KK01003 KK01009	KK01000 KK01002	KK01000 KK01002	KK01000 KK01002	KK01000 KK01002
	AA00788			AA00788					AA00788		
MA00001	MA00001	MA00001		MA00001			MA00002	MA00001	MA00001	MA00001	MA00001
	PL04055 PL04056	PL04055 PL04056		PL04055 PL04056			PL04058	PL04055 PL04056	PL04055 PL04056	PL04055 PL04056	PL04055 PL04056
9913300	9913300	9913300		9913300				9913300	9913300	9913300	9913300
	9909520			9909520					9909520		
RE00014		RE00014		RE00014				RE00014	RE00014	RE00014	RE00014
AA00767 RL00001	AA00767 RL00001	AA00767 RL00001		AA00767 RL00001				AA00767 RL00001	AA00767 RL00001	AA00767 RL00001	AA00767 RL00001
9906520	9908370	9908370		9908370			9910930	9908370	9908370	9908370	9908370

SCOOTER 50cc

SCOOTER 50cc

TOP
- performances -



APRILIA	APRILIA	APRILIA	APRILIA
SCARABEO	SCARABEO	SCARABEO 2T	SCARABEO 2T EU2 MOTORE PIAGGIO
99-99	00-05	14-14	10-12
50cc 2T AC	50cc 2T AC	50cc 2T LC	50cc 2T AC
MY	MY	Motore Piaggio	Motore Piaggio
C107487	C107487		C107494
IM07059	IM07059		IM07060
IM07014	IM07014		IM07015
IM07032	IM07032		IM07031
9924940	9924940		9924950
9910100	9910100		
9907770	9907770		
9935270	9935270	9935420	9935420
CT00725	CT00725		CT00727
9911060	9911060		
9910020 9925130	9910020 9925130		9910020
9931140	9931140		9914500
KT00095	KT00095		KT00080
9931340 KT00087	9931340 KT00087		9931250 KT00086
9911090	9911090		
KK01000 KK01002	KK01000 KK01002		KK01003 KK01009
MA00001	MA00001		MA00002
PL04055 PL04056	PL04055 PL04056	PL04058	PL04058
9913300	9913300		
RE00014	RE00014		RE00012
AA00767 RL00001	AA00767 RL00001		RL00040
9908370	9908370		9910930

IT	EN	FR
ALBERO MESSA IN MOTO	KICK SHAFT	ARBRE DE DEMARREUR
ALBERO MOTORE Con Cuscinetti e Paraoli	CRANKSHAFT with bearings and oil seals	VILEBREQUIN doté de Paliers et Joints d'huile
ALBERO MOTORE Senza Cuscinetti e Paraoli	CRANKSHAFT without bearings and oil seals	VILEBREQUIN sans Paliers et Joints d'huile
BIELLA	CONROD	BIELLE
CAMPANA FRIZIONE	CLUTCH HOUSING	CLOCHE EMBRAYAGE
CENTRALINA AD ANTICIPO FISSO	DIGITAL IGNITION UNIT	ALLUMAGE Fixe
CENTRALINA AD ANTICIPO VARIABILE 4T	IGNITION UNIT Variable	ALLUMAGE Numérique
CINGHIA DI TRASMISSIONE TOP	TRANSMISSION BELT TOP PERFORMANCES	COURROIE DE TRANSMISSION TOP PERFORMANCES
CINGHIA DI TRASMISSIONE Mitsubishi	TRANSMISSION BELT Mitsubishi	COURROIE DE TRANSMISSION Mitsubishi
COLLETTORE ASPIRAZIONE	INLET MANIFOLD	COLLECTEUR ASPIRATION
FRIZIONE CENTRIFUGA Interno Ø 105	CENTRIFUGAL CLUTCH Ø 105	EMBAYAGE CENTRIFUGE Ø 105
FRIZIONE CENTRIFUGA Interno Ø 107	CENTRIFUGAL CLUTCH Ø 107	EMBAYAGE CENTRIFUGE Ø 107
GANASCE FRENO	BRAKE SHOES	MÂCHOIRES FREIN
GRUPPO TERMICO Ø Standard c/testa	CYLINDER KIT Ø standard with head	CYLINDRE COMPLET Ø Standard avec culasse
GRUPPO TERMICO Ø Standard s/testa	CYLINDER KIT Ø standard without head	CYLINDRE COMPLET Ø Standard sans culasse
GRUPPO TERMICO Ø Magg. c/testa	CYLINDER KIT BIG BORE with head	CYLINDRE COMPLET Ø Majoré avec culasse
GRUPPO TERMICO Ø Magg. s/testa	CYLINDER KIT BIG BORE without head	CYLINDRE COMPLET Ø Majoré sans culasse
GRUPPO TERMICO Modifica da AC a LC	CYLINDER KIT Conversion AC to LC	CYLINDRE COMPLET Modification de AC à LC
KIT CUSCINETTI DA BANCO	BEARINGS KIT	KIT PALIERS DE VILEBREQUIN
KIT REVISIONE POMPA ACQUA	WATER PUMP REPAIR KIT	KIT RÉVISION POMPE À EAU
MEMBRANA CARBURATORE	CARBURETOR DIAPHRAGM	MEMBRANE CARBURATEUR
MOTORINO D'AVVIAMENTO	STARTER ENGINE	DÉMARREUR ÉLECTRIQUE
PULEGGIA FISSA	VARIATOR SHEAVE FIXED	POULIE FIXE
RAPPORTI ALLUNGATI Primari	GÉARS KIT Primary	RAPPORTS ALLONGÉS Primaires
RAPPORTI ALLUNGATI Secondari	GÉARS KIT Secondary	RAPPORTS ALLONGÉS Secondaires
REGOLATORE DI TENSIONE	RECTIFIER	RÉGULATEUR DE TENSION
RUOTA LIBERA	STARTER CLUTCH	ROUE LIBRE
STATORE	STATOR	STATOR
VALVOLE LAMELLARI	REED VALVE	CLAPET À LAMELLES

APRILIA	APRILIA	APRILIA	APRILIA	APRILIA	APRILIA	APRILIA	APRILIA	APRILIA	APRILIA	APRILIA	APRILIA
SCARABEO 2T NET	SCARABEO 2T NET	SCARABEO 4T	SCARABEO 4T 4V	SCARABEO 4T 4V	SCARABEO 4T 4V NET	SCARABEO 4T 4V NET	SCARABEO 4T RESTYLING EU3	SCARABEO DITECH	SCARABEO QUATTRO	SCARABEO STREET	SCARABEO STREET 2T RESTYLING
09-09	10-10	02-06	10-12	14-17	09-09	10-10	06-09	01-04	09-09	05-06	06-09
50cc 2T AC	50cc 2T AC	50cc 4T AC	50cc 4T-4V AC	50cc 4T-4V AC	50cc 4T-4V AC	50cc 4T-4V AC	50cc 4T AC	50cc 2T-IE AC	50cc 4T-4V AC	50cc 2T AC	50cc 2T AC
Motore Piaggio	Motore Piaggio	Motore Piaggio	Motore Piaggio	Motore Piaggio	Motore Piaggio	Motore Piaggio	Motore Piaggio	Motore Aprilia	Motore Piaggio	Motore Piaggio	Motore Piaggio
CI07494	CI07494	CI07494	CI07494		CI07494	CI07494	CI07494		CI07494	CI07494	CI07494
IM07060	IM07060									IM07060	IM07060
IM07015	IM07015	IM07073	IM07073	IM07073	IM07073	IM07073	IM07073	IM07044	IM07073	IM07015	IM07015
IM07031	IM07031									IM07031	IM07031
9924950	9924950	9924950	9924950		9924950	9924950	9924950		9924950	9924950	9924950
								9920440			
9935420	9935420	9935420	9935420	9935420	9935420	9935420	9935420	9935820	9935420	9935420	9935420
CT00727	CT00727	CT00738					CT00737			CT00727	CT00727
9910020	9910020	9910020	9910020		9910020	9910020	9910020		9910020	9910020	9910020
9914500	9914500									9914500	9914500
KT00080	KT00080									KT00080	KT00080
9931250 KT00086	9931250 KT00086									9931250 KT00086	9931250 KT00086
		9925150 KT00133	9928300	9928300	9928300	9928300	9925150 KT00133		9928300		
KK01003 KK01009	KK01003 KK01009									KK01003 KK01009	KK01003 KK01009
MA00002	MA00002	MA00015	MA00015		MA00015	MA00015	MA00015		MA00015	MA00002	MA00002
PL04058	PL04058	PL04058	PL04058	PL04058	PL04058	PL04058	PL04058		PL04058	PL04058	PL04058
RE00012	RE00012 RE00014	RE00018					RE00018			RE00012	RE00012
RL00040	RL00040	RL00039	RL00039		RL00039	RL00039	RL00039		RL00039	RL00040	RL00040
		ST00004					ST00004				
9910930	9910930									9910930	9910930

SCOOTER 50cc

SCOOTER 50cc

TOP
- performances -



APRILIA	APRILIA	APRILIA	APRILIA
SONIC	SONIC GP	SPORT CITY ONE 2T	SPORT CITY ONE 4T
98-07	98-08	08-11	08-10
50cc 2T AC	50cc 2T LC	50cc 2T AC	50cc 4T AC
CY	CA	Motore Piaggio	Motore Piaggio

IT	EN	FR					
ALBERO MESSA IN MOTO	KICK SHAFT	ARBRE DE DEMARREUR					
ALBERO MOTORE Con Cuscinetti e Paraoli	CRANKSHAFT with bearings and oil seals	VILEBREQUIN doté de Paliers et Joints d'huile		IM07059	IM07059	IM07060	
ALBERO MOTORE Senza Cuscinetti e Paraoli	CRANKSHAFT without bearings and oil seals	VILEBREQUIN sans Paliers et Joints d'huile		IM07014	IM07014	IM07015	IM07073
BIELLA	CONROD	BIELLE		IM07032	IM07032	IM07031	
CAMPANA FRIZIONE	CLUTCH HOUSING	CLOCHE EMBRAYAGE		9924940	9924940	9924950	9924950
CENTRALINA AD ANTICIPO FISSO	DIGITAL IGNITION UNIT	ALLUMAGE Fixe		9910100	9910100		
CENTRALINA AD ANTICIPO VARIABILE 4T	IGNITION UNIT Variable	ALLUMAGE Numérique					
CINGHIA DI TRASMISSIONE TOP	TRANSMISSION BELT TOP PERFORMANCES	COURROIE DE TRANSMISSION TOP PERFORMANCES		9907900	9907900		
CINGHIA DI TRASMISSIONE Mitsubishi	TRANSMISSION BELT Mitsubishi	COURROIE DE TRANSMISSION Mitsubishi		9935340	9935340	9935420	9935420
COLLETTORE ASPIRAZIONE	INLET MANIFOLD	COLLECTEUR ASPIRATION		CT00725	CT00725	CT00727	CT00737
FRIZIONE CENTRIFUGA Interno Ø 105	CENTRIFUGAL CLUTCH Ø 105	EMBAYAGE CENTRIFUGE Ø 105		9911060	9911060		
FRIZIONE CENTRIFUGA Interno Ø 107	CENTRIFUGAL CLUTCH Ø 107	EMBAYAGE CENTRIFUGE Ø 107		9910020 9925130	9910020 9925130	9910020	9910020
GANASCE FRENO	BRAKE SHOES	MÂCHOIRES FREIN					
GRUPPO TERMICO Ø Standard c/testa	CYLINDER KIT Ø standard with head	CYLINDRE COMPLET Ø Standard avec culasse		9931140	9931110	9914500	
GRUPPO TERMICO Ø Standard s/testa	CYLINDER KIT Ø standard without head	CYLINDRE COMPLET Ø Standard sans culasse		KT00095	KT00094	KT00080	
GRUPPO TERMICO Ø Magg. c/testa	CYLINDER KIT BIG BORE with head	CYLINDRE COMPLET Ø Majoré avec culasse		9931340 KT00087	9931310 KT00109	9931250 KT00086	
GRUPPO TERMICO Ø Magg. s/testa	CYLINDER KIT BIG BORE without head	CYLINDRE COMPLET Ø Majoré sans culasse					9925150 KT00133
GRUPPO TERMICO Modifica da AC a LC	CYLINDER KIT Conversion AC to LC	CYLINDRE COMPLET Modification de AC à LC		9911090			
KIT CUSCINETTI DA BANCO	BEARINGS KIT	KIT PALIERS DE VILEBREQUIN		KK01000 KK01002	KK01000 KK01002	KK01003 KK01009	
KIT REVISIONE POMPA ACQUA	WATER PUMP REPAIR KIT	KIT RÉVISION POMPE À EAU			AA00788		
MEMBRANA CARBURATORE	CARBURETOR DIAPHRAGM	MEMBRANE CARBURATEUR					
MOTORINO D'AVVIAMENTO	STARTER ENGINE	DÉMARREUR ÉLECTRIQUE		MA00001	MA00001	MA00002	MA00015
PULEGGIA FISSA	VARIATOR SHEAVE FIXED	POULIE FIXE		PL04055 PL04056	PL04055 PL04056	PL04058	PL04058
RAPPORTI ALLUNGATI Primari	GÉARS KIT Primary	RAPPORTS ALLONGÉS Primaires					
RAPPORTI ALLUNGATI Secondari	GÉARS KIT Secondary	RAPPORTS ALLONGÉS Secondaires					
REGOLATORE DI TENSIONE	RECTIFIER	RÉGULATEUR DE TENSION		RE00014	RE00014	RE00012	
RUOTA LIBERA	STARTER CLUTCH	ROUE LIBRE		AA00767 RL00001	AA00767 RL00001	RL00040	RL00039
STATORE	STATOR	STATOR					ST00004
VALVOLE LAMELLARI	REED VALVE	CLAPET À LAMELLES		9908370	9908370	9910930	

APRILIA	APRILIA	APRILIA	APRILIA	APRILIA	APRILIA	APRILIA	APRILIA	APRILIA	APRILIA	APRILIA	APRILIA
SR (ORIZZON- TALE)	SR (VERTI- CALE)	SR CARBURA- TORE	SR DITECH EU2	SR H2O CAR- BURATORE	SR H2O DITECH	SR LIQUID COOLED	SR MOTARD	SR MOTARD 4T 4V	SR R	SR R FACTORY CARBURATORE	SR R FACTORY IE
94-96	93-93	14-14	02-04	00-03	00-04	94-96	12-14	13-19	04-09	10-14	10-12
50cc 2T AC	50cc 2T AC	50cc 2T LC	50cc 2T-IE LC	50cc 2T LC	50cc 2T-IE LC	50cc 2T LC	50cc 2T LC	50cc 4T-4V LC	50cc 2T LC	50cc 2T LC	50cc 2T-IE LC
MY	CW	Motore Piaggio	Motore Aprilia	Motore Aprilia	Motore Aprilia	MA	Motore Piaggio	Motore Piaggio	Motore Piaggio	Motore Piaggio	Motore Piaggio
CI07487	CI07487					CI07487	CI07494		CI07494	CI07494	
IM07059	IM07058					IM07059	IM07060		IM07060	IM07060	
IM07014	IM07013		IM07044		IM07044	IM07014	IM07015	IM07073	IM07015	IM07015	
IM07032	IM07032					IM07032	IM07031		IM07031	IM07031	
9924940						9924940	9924950		9924950	9924950	
9910100						9910100					
9907770	9907770		9920440		9920440	9907770	9922030		9922030	9922030	
9935270	9935270	9935830	9935820		9935820	9935270	9935420	9935420	9935830	9935830	
CT00725	CT00726					CT00725	CT00727		CT00727	CT00727	
9911060	9911060					9911060					
9910020 9925130	9910020 9925130					9910020 9925130	9910020		9910020	9910020	
9931140	9931170					9931110	9916580 KT00112		9916580 KT00112	9916580 KT00112	
KT00095	KT00096					KT00094					
9931340 KT00087	9931370 KT00088					9931310 KT00109	9931270 KT00097		9931270 KT00097	9931270 KT00097	
								9928300			
9911090											
KK01000 KK01002	KK01000 KK01002					KK01000 KK01002	KK01003 KK01009		KK01003 KK01009	KK01003 KK01009	KK01003 KK01009
		AA00796	AA00809	AA00809	AA00809	AA00788	AA00796		AA00796	AA00796	AA00796
MA00001	MA00001					MA00001	MA00002		MA00015	MA00002	
PL04055 PL04056		PL04058	PL04063	PL04063	PL04063	PL04055 PL04056	PL04058	PL04058	PL04058	PL04058	PL04058
9913300	9913300					9913300					
9909520						9909520					
RE00014	RE00014					RE00014	RE00012		RE00012	RE00012	
AA00767 RL00001	AA00767 RL00001					AA00767 RL00001	RL00040		RL00039	RL00040	
9908370	9906520					9908370	9910930		9910930	9910930	

SCOOTER 50cc

TOP
- performances -



APRILIA	APRILIA	APRILIA	APRILIA
SR R FACTORY IE	SR R FACTORY MOTORE APRILIA	SR RACING	SR RACING
10-14	05-05	97-99	97-00
50cc 2T LC	50cc 2T-IE LC	50cc 2T LC	50cc 2T LC
Motore Piaggio	Motore Aprilia	MA	MA

IT	EN	FR				
ALBERO MESSA IN MOTO	KICK SHAFT	ARBRE DE DEMARREUR		CI07494		CI07487
ALBERO MOTORE Con Cuscinetti e Paraoli	CRANKSHAFT with bearings and oil seals	VILEBREQUIN doté de Paliers et Joints d'huile		IM07060		IM07059
ALBERO MOTORE Senza Cuscinetti e Paraoli	CRANKSHAFT without bearings and oil seals	VILEBREQUIN sans Paliers et Joints d'huile		IM07015	IM07044	IM07014
BIELLA	CONROD	BIELLE		IM07031		IM07032
CAMPANA FRIZIONE	CLUTCH HOUSING	CLOCHE EMBRAYAGE		9924950		9924940
CENTRALINA AD ANTICIPO FISSO	DIGITAL IGNITION UNIT	ALLUMAGE Fixe				9910100
CENTRALINA AD ANTICIPO VARIABILE 4T	IGNITION UNIT Variable	ALLUMAGE Numérique				
CINGHIA DI TRASMISSIONE TOP	TRANSMISSION BELT TOP PERFORMANCES	COURROIE DE TRANSMISSION TOP PERFORMANCES		9922030	9920440	9907770
CINGHIA DI TRASMISSIONE Mitsubishi	TRANSMISSION BELT Mitsubishi	COURROIE DE TRANSMISSION Mitsubishi		9935830	9935820	9935270
COLLETTORE ASPIRAZIONE	INLET MANIFOLD	COLLECTEUR ASPIRATION		CT00727		CT00725
FRIZIONE CENTRIFUGA Interno Ø 105	CENTRIFUGAL CLUTCH Ø 105	EMBAYAGE CENTRIFUGE Ø 105				9911060
FRIZIONE CENTRIFUGA Interno Ø 107	CENTRIFUGAL CLUTCH Ø 107	EMBAYAGE CENTRIFUGE Ø 107		9910020		9910020 9925130
GANASCE FRENO	BRAKE SHOES	MÂCHOIRES FREIN				
GRUPPO TERMICO Ø Standard c/testa	CYLINDER KIT Ø standard with head	CYLINDRE COMPLET Ø Standard avec culasse		9916580 KT00112		9931110
GRUPPO TERMICO Ø Standard s/testa	CYLINDER KIT Ø standard without head	CYLINDRE COMPLET Ø Standard sans culasse				KT00094
GRUPPO TERMICO Ø Magg. c/testa	CYLINDER KIT BIG BORE with head	CYLINDRE COMPLET Ø Majoré avec culasse		9931270 KT00097		9931310 KT00109
GRUPPO TERMICO Ø Magg. s/testa	CYLINDER KIT BIG BORE without head	CYLINDRE COMPLET Ø Majoré sans culasse				
GRUPPO TERMICO Modifica da AC a LC	CYLINDER KIT Conversion AC to LC	CYLINDRE COMPLET Modification de AC à LC				
KIT CUSCINETTI DA BANCO	BEARINGS KIT	KIT PALIERS DE VILEBREQUIN		KK01003 KK01009		KK01000 KK01002
KIT REVISIONE POMPA ACQUA	WATER PUMP REPAIR KIT	KIT RÉVISION POMPE À EAU		AA00796	AA00809	AA00788 AA00788
MEMBRANA CARBURATORE	CARBURETOR DIAPHRAGM	MEMBRANE CARBURATEUR				
MOTORINO D'AVVIAMENTO	STARTER ENGINE	DÉMARREUR ÉLECTRIQUE		MA00015		MA00001
PULEGGIA FISSA	VARIATOR SHEAVE FIXED	POULIE FIXE		PL04058	PL04063	PL04055 PL04056 PL04056
RAPPORTI ALLUNGATI Primari	GÉARS KIT Primary	RAPPORTS ALLONGÉS Primaires				9913300
RAPPORTI ALLUNGATI Secondari	GÉARS KIT Secondary	RAPPORTS ALLONGÉS Secondaires				9909520
REGOLATORE DI TENSIONE	RECTIFIER	RÉGULATEUR DE TENSION				RE00014
RUOTA LIBERA	STARTER CLUTCH	ROUE LIBRE		RL00039		AA00767 RL00001
STATORE	STATOR	STATOR				
VALVOLE LAMELLARI	REED VALVE	CLAPET À LAMELLES		9910930		9908370

APRILIA	APRILIA	APRILIA	APRILIA	ATALA	ATALA	ATALA	BAOTIAN	BAOTIAN	BAOTIAN	BAOTIAN	BENELLI
SR STEALTH	SR STEALTH	SR STREET CARBURATORE	SR WWW	CAROSELLO	HACKER	VAMOS	ECO BIKE	REBEL	ROCHY	TANCO	491 GT
97-00	97-00	03-12	97-01	99-01	95-00	93-95	00-04	03-06	03-06	03-06	98-99
50cc 2T LC	50cc 2T LC	50cc 2T LC	50cc 2T AC	50cc 2T AC	50cc 2T AC	50cc 2T AC	50cc 4T AC	50cc 4T AC	50cc 4T AC	50cc 4T AC	50cc 2T
MA	MA	Motore Piaggio	MY	MY	Motore Morini	Motore Morini	Tipo Kymco	Tipo Kymco	Tipo Kymco	Tipo Kymco	MY
CI07487		CI07494	CI07487	CI07487							
IM07059		IM07060	IM07059	IM07059							
IM07014		IM07015	IM07014	IM07014							
IM07032		IM07031	IM07032	IM07032							
9924940		9924950	9924940	9924940							
9910100			9910100								
9907770		9922030	9907770	9907770							
9935270		9935830	9935270	9935270							
CT00725		CT00727	CT00725	CT00725							
9911060			9911060	9911060							
9910020 9925130		9910020	9910020 9925130	9910020 9925130							
											CP00219
9931110		9916580 KT00112	9931140	9931140							
KT00094			KT00095	KT00095							
9931310 KT00109		9931270 KT00097	9931340 KT00087	9931340 KT00087							
					KT00057	KT00057	9925140 KT00132	9925140 KT00132	9925140 KT00132	9925140 KT00132	
			9911090	9911090							
KK01000 KK01002		KK01003 KK01009	KK01000 KK01002	KK01000 KK01002							
AA00788	AA00788	AA00796									
MA00001		MA00002	MA00001	MA00001							
PL04055 PL04056	PL04055 PL04056	PL04058	PL04055 PL04056	PL04055 PL04056							
9913300			9913300	9913300							
9909520											
RE00012 RE00014		RE00012	RE00014								
AA00767 RL00001		RL00040	AA00767 RL00001	AA00767 RL00001							
9908370		9910930	9908370	9908370							

SCOOTER 50cc

TOP
- performances -



BENELLI	BENELLI	BENELLI	BENELLI
491 GT	491 NAKED	491 RACING	491 RR
98-99	02-02	98-99	99-01
50cc 2T AC	50cc 2T AC	50cc 2T LC	50cc 2T LC
MY	MY	MA	MA

IT	EN	FR					
ALBERO MESSA IN MOTO	KICK SHAFT	ARBRE DE DEMARREUR		C107487	C107487	C107487	C107487
ALBERO MOTORE Con Cuscinetti e Paraoli	CRANKSHAFT with bearings and oil seals	VILEBREQUIN doté de Paliers et Joints d'huile		IM07059	IM07059	IM07059	IM07059
ALBERO MOTORE Senza Cuscinetti e Paraoli	CRANKSHAFT without bearings and oil seals	VILEBREQUIN sans Paliers et Joints d'huile		IM07014	IM07014	IM07014	IM07014
BIELLA	CONROD	BIELLE		IM07032	IM07032	IM07032	IM07032
CAMPANA FRIZIONE	CLUTCH HOUSING	CLOCHE EMBRAYAGE		9924940	9924940	9924940	9924940
CENTRALINA AD ANTICIPO FISSO	DIGITAL IGNITION UNIT	ALLUMAGE Fixe		9910100	9910100	9910100	9910100
CENTRALINA AD ANTICIPO VARIABILE 4T	IGNITION UNIT Variable	ALLUMAGE Numérique					
CINGHIA DI TRASMISSIONE TOP	TRANSMISSION BELT TOP PERFORMANCES	COURROIE DE TRANSMISSION TOP PERFORMANCES		9907770	9907770	9907770	9907770
CINGHIA DI TRASMISSIONE Mitsubishi	TRANSMISSION BELT Mitsubishi	COURROIE DE TRANSMISSION Mitsubishi		9935270	9935270	9935270	9935270
COLLETTORE ASPIRAZIONE	INLET MANIFOLD	COLLECTEUR ASPIRATION		CT00725	CT00725	CT00725	CT00725
FRIZIONE CENTRIFUGA Interno Ø 105	CENTRIFUGAL CLUTCH Ø 105	EMBAYAGE CENTRIFUGE Ø 105		9911060	9911060	9911060	9911060
FRIZIONE CENTRIFUGA Interno Ø 107	CENTRIFUGAL CLUTCH Ø 107	EMBAYAGE CENTRIFUGE Ø 107		9910020 9925130	9910020 9925130	9910020 9925130	9910020 9925130
GANASCE FRENO	BRAKE SHOES	MÂCHOIRES FREIN					
GRUPPO TERMICO Ø Standard c/testa	CYLINDER KIT Ø standard with head	CYLINDRE COMPLET Ø Standard avec culasse		9931140	9931140	9931110	9931110
GRUPPO TERMICO Ø Standard s/testa	CYLINDER KIT Ø standard without head	CYLINDRE COMPLET Ø Standard sans culasse		KT00095	KT00095	KT00094	KT00094
GRUPPO TERMICO Ø Magg. c/testa	CYLINDER KIT BIG BORE with head	CYLINDRE COMPLET Ø Majoré avec culasse		9931340 KT00087	9931340 KT00087	9931310 KT00109	9931310 KT00109
GRUPPO TERMICO Ø Magg. s/testa	CYLINDER KIT BIG BORE without head	CYLINDRE COMPLET Ø Majoré sans culasse					
GRUPPO TERMICO Modifica da AC a LC	CYLINDER KIT Conversion AC to LC	CYLINDRE COMPLET Modification de AC à LC		9911090	9911090		
KIT CUSCINETTI DA BANCO	BEARINGS KIT	KIT PALIERS DE VILEBREQUIN		KK01000 KK01002	KK01000 KK01002	KK01000 KK01002	KK01000 KK01002
KIT REVISIONE POMPA ACQUA	WATER PUMP REPAIR KIT	KIT RÉVISION POMPE À EAU				AA00788	AA00788
MEMBRANA CARBURATORE	CARBURETOR DIAPHRAGM	MEMBRANE CARBURATEUR					
MOTORINO D'AVVIAMENTO	STARTER ENGINE	DÉMARREUR ÉLECTRIQUE		MA00001	MA00001	MA00001	MA00001
PULEGGIA FISSA	VARIATOR SHEAVE FIXED	POULIE FIXE		PL04055 PL04056	PL04055 PL04056	PL04055 PL04056	PL04055 PL04056
RAPPORTI ALLUNGATI Primari	GÉARS KIT Primary	RAPPORTS ALLONGÉS Primaires		9913300	9913300	9913300	9913300
RAPPORTI ALLUNGATI Secondari	GÉARS KIT Secondary	RAPPORTS ALLONGÉS Secondaires		9909520		9909520	9909520
REGOLATORE DI TENSIONE	RECTIFIER	RÉGULATEUR DE TENSION					
RUOTA LIBERA	STARTER CLUTCH	ROUE LIBRE		AA00767 RL00001	AA00767 RL00001	AA00767 RL00001	AA00767 RL00001
STATORE	STATOR	STATOR					
VALVOLE LAMELLARI	REED VALVE	CLAPET À LAMELLES		9908370	9908370	9908370	9908370

BENELLI	BENELLI	BENELLI	BENELLI	BENELLI	BENELLI	BENELLI	BENELLI	BENELLI	BENELLI	BENELLI	BENELLI
491 SP	491 SPORT	491 SPORT	491 ST	491 ST MORINI	K2	K2 LIQUID COOLED	NAKED MORINI	PEPE	PEPE	PEPE LX	PEPE LX
99-99	98-99	98-99	99-01	03-03	98-01	98-01	03-04	99-01	10-10	03-04	07-09
50cc 2T LC	50cc 2T	50cc 2T LC	50cc 2T AC	50cc 2T AC	50cc 2T AC	50cc 2T LC	50cc 2T AC	50cc 2T AC	50cc 2T AC	50cc 2T AC	50cc 2T AC
MA	MA	MA	MY	Motore Morini	MY	MA	Motore Morini	MY	Tipo Keeway	MY	Tipo Keeway
CI07487		CI07487	CI07487		CI07487	CI07487		CI07487		CI07487	
IM07059		IM07059	IM07059		IM07059	IM07059		IM07059		IM07059	
IM07014		IM07014	IM07014		IM07014	IM07014		IM07014		IM07014	
IM07032		IM07032	IM07032		IM07032	IM07032		IM07032		IM07032	
9924940		9924940	9924940		9924940	9924940		9924940		9924940	
9910100		9910100	9910100		9910100	9910100		9910100		9910100	
9907770		9907770	9907770		9907770	9907770		9907770	9913280	9907770	9913280
9935270		9935270	9935270		9935270	9935270		9935270	9935800	9935270	9935800
CT00725		CT00725	CT00725		CT00725	CT00725		CT00725		CT00725	
9911060		9911060	9911060		9911060	9911060		9911060		9911060	
9910020 9925130		9910020 9925130	9910020 9925130		9910020 9925130	9910020 9925130		9910020 9925130	9925130	9910020 9925130	9925130
	CP00219										
9931110		9931110	9931140		9931140	9931110		9931140	9925650	9931140	9925650
KT00094		KT00094	KT00095		KT00095	KT00094		KT00095	KT00129	KT00095	KT00129
9931310 KT00109		9931310 KT00109	9931340 KT00087		9931340 KT00087	9931310 KT00109		9931340 KT00087	9924890 KT00128	9931340 KT00087	9924890 KT00128
				KT00057			KT00057				
			9911090		9911090			9911090		9911090	
KK01000 KK01002		KK01000 KK01002	KK01000 KK01002		KK01000 KK01002	KK01000 KK01002		KK01000 KK01002		KK01000 KK01002	
AA00788		AA00788				AA00788					
MA00001		MA00001	MA00001		MA00001	MA00001		MA00001		MA00001	
PL04055 PL04056		PL04055 PL04056	PL04055 PL04056		PL04055 PL04056	PL04055 PL04056		PL04055 PL04056		PL04055 PL04056	
9913300		9913300	9913300		9913300	9913300		9913300		9913300	
9909520		9909520	9909520					9909520		9909520	
AA00767 RL00001		AA00767 RL00001	AA00767 RL00001		AA00767 RL00001	AA00767 RL00001		AA00767 RL00001		AA00767 RL00001	
9908370		9908370	9908370		9908370	9908370		9908370		9908370	

SCOOTER 50cc

SCOOTER 50cc

TOP
- performances -



BENELLI	BENELLI	BENELLI	BENELLI
PEPE OLD	PEPE OLD	QUATTRONONEX	QUATTRONONEX
07-09	11-11	08-09	10-10
50cc 2T AC	50cc 2T AC	50cc 2T AC	50cc 2T AC
Tipo Keeway	Tipo Keeway	Tipo Keeway	Tipo Keeway

IT	EN	FR				
ALBERO MESSA IN MOTO	KICK SHAFT	ARBRE DE DEMARREUR				
ALBERO MOTORE Con Cuscinetti e Paraoli	CRANKSHAFT with bearings and oil seals	VILEBREQUIN doté de Paliers et Joints d'huile				
ALBERO MOTORE Senza Cuscinetti e Paraoli	CRANKSHAFT without bearings and oil seals	VILEBREQUIN sans Paliers et Joints d'huile				
BIELLA	CONROD	BIELLE				
CAMPANA FRIZIONE	CLUTCH HOUSING	CLOCHE EMBRAYAGE				
CENTRALINA AD ANTICIPO FISSO	DIGITAL IGNITION UNIT	ALLUMAGE Fixe				
CENTRALINA AD ANTICIPO VARIABILE 4T	IGNITION UNIT Variable	ALLUMAGE Numérique				
CINGHIA DI TRASMISSIONE TOP	TRANSMISSION BELT TOP PERFORMANCES	COURROIE DE TRANSMISSION TOP PERFORMANCES		9913280	9913280	9913280
CINGHIA DI TRASMISSIONE Mitsubishi	TRANSMISSION BELT Mitsubishi	COURROIE DE TRANSMISSION Mitsubishi		9935800	9935800	9935800
COLLETTORE ASPIRAZIONE	INLET MANIFOLD	COLLECTEUR ASPIRATION				
FRIZIONE CENTRIFUGA Interno Ø 105	CENTRIFUGAL CLUTCH Ø 105	EMBAYAGE CENTRIFUGE Ø 105				
FRIZIONE CENTRIFUGA Interno Ø 107	CENTRIFUGAL CLUTCH Ø 107	EMBAYAGE CENTRIFUGE Ø 107		9925130	9925130	9925130
GANASCE FRENO	BRAKE SHOES	MÂCHOIRES FREIN				
GRUPPO TERMICO Ø Standard c/testa	CYLINDER KIT Ø standard with head	CYLINDRE COMPLET Ø Standard avec culasse		9925650	9925650	9925650
GRUPPO TERMICO Ø Standard s/testa	CYLINDER KIT Ø standard without head	CYLINDRE COMPLET Ø Standard sans culasse		KT00129	KT00129	KT00129
GRUPPO TERMICO Ø Magg. c/testa	CYLINDER KIT BIG BORE with head	CYLINDRE COMPLET Ø Majoré avec culasse		9924890 KT00128	9924890 KT00128	9924890 KT00128
GRUPPO TERMICO Ø Magg. s/testa	CYLINDER KIT BIG BORE without head	CYLINDRE COMPLET Ø Majoré sans culasse				
GRUPPO TERMICO Modifica da AC a LC	CYLINDER KIT Conversion AC to LC	CYLINDRE COMPLET Modification de AC à LC				
KIT CUSCINETTI DA BANCO	BEARINGS KIT	KIT PALIERS DE VILEBREQUIN				
KIT REVISIONE POMPA ACQUA	WATER PUMP REPAIR KIT	KIT RÉVISION POMPE À EAU				
MEMBRANA CARBURATORE	CARBURETOR DIAPHRAGM	MEMBRANE CARBURATEUR				
MOTORINO D'AVVIAMENTO	STARTER ENGINE	DÉMARREUR ÉLECTRIQUE				
PULEGGIA FISSA	VARIATOR SHEAVE FIXED	POULIE FIXE				
RAPPORTI ALLUNGATI Primari	GÉARS KIT Primary	RAPPORTS ALLONGÉS Primaires				
RAPPORTI ALLUNGATI Secondari	GÉARS KIT Secondary	RAPPORTS ALLONGÉS Secondaires				
REGOLATORE DI TENSIONE	RECTIFIER	RÉGULATEUR DE TENSION				
RUOTA LIBERA	STARTER CLUTCH	ROUE LIBRE				
STATORE	STATOR	STATOR				
VALVOLE LAMELLARI	REED VALVE	CLAPET À LAMELLES				

BENELLI	BETA	BETA	BETA	BETA	BETA	BETA	BETA	BETA	BETA	BSV	BSV
QUATTRONONEX	ARK	ARK LC	CHRONO	CHRONO	EIKON	QUADRA	QUADRA	TEMPO	TEMPO	DIO GP	DIO SP
11-11	96-08	96-08	95-97	96-96	99-03	95-95	99-01	93-02	95-95	94-96	94-96
50cc 2T AC	50cc 2T AC	50cc 2T LC	50cc 2T AC	50cc 2T AC	50cc 2T LC	50cc 2T AC	50cc 2T AC	50cc 2T AC	50cc 2T AC	50cc 2T AC	50cc 2T AC
Tipo Keeway	MY	MA	MY	MY	MA	MY	MY	MY	MY	Motore Honda	Motore Honda
	CI07487	CI07487	CI07487	CI07487	CI07487	CI07487	CI07487	CI07487	CI07487		
	IM07059	IM07059	IM07059	IM07059	IM07059	IM07059	IM07059	IM07059	IM07059		
	IM07014	IM07014	IM07014	IM07014	IM07014	IM07014	IM07014	IM07014	IM07014		
	IM07032	IM07032	IM07032	IM07032	IM07032	IM07032	IM07032	IM07032	IM07032		
	9924940	9924940	9924940	9924940	9924940	9924940	9924940	9924940	9924940		
			9910100		9910100		9910100	9910100			
9913280	9907770	9907770	9907770	9907770	9907770	9907770	9907770	9907770	9907770		
9935800	9935270	9935270	9935270	9935270	9935270	9935270	9935270	9935270	9935270		
	CT00725	CT00725	CT00725	CT00725	CT00725	CT00725	CT00725	CT00725	CT00725		
	9911060	9911060	9911060	9911060	9911060	9911060	9911060	9911060	9911060		
9925130	9910020 9925130	9910020 9925130	9910020 9925130	9910020 9925130	9910020 9925130	9910020 9925130	9910020 9925130	9910020 9925130	9910020 9925130	9910020	9910020
9925650	9931140	9931110	9931140	9931140	9931110	9931140	9931140	9931140	9931140		
KT00129	KT00095	KT00094	KT00095	KT00095	KT00094	KT00095	KT00095	KT00095	KT00095		
9924890 KT00128	9931340 KT00087	9931310 KT00109	9931340 KT00087	9931340 KT00087	9931310 KT00109	9931340 KT00087	9931340 KT00087	9931340 KT00087	9931340 KT00087		
	9911090		9911090	9911090		9911090	9911090	9911090	9911090		
	KK01000 KK01002	KK01000 KK01002	KK01000 KK01002	KK01000 KK01002	KK01000 KK01002	KK01000 KK01002	KK01000 KK01002	KK01000 KK01002	KK01000 KK01002		
		AA00788			AA00788						
	MA00001	MA00001	MA00001	MA00001	MA00001	MA00001	MA00001	MA00001	MA00001		
	PL04055 PL04056	PL04055 PL04056	PL04055 PL04056	PL04055 PL04056	PL04055 PL04056	PL04055 PL04056	PL04055 PL04056	PL04055 PL04056	PL04055 PL04056		
	9913300	9913300	9913300	9913300	9913300	9913300	9913300	9913300	9913300		
		9909520			9909520						
	AA00767 RL00001	AA00767 RL00001	AA00767 RL00001	AA00767 RL00001	AA00767 RL00001	AA00767 RL00001	AA00767 RL00001	AA00767 RL00001	AA00767 RL00001		
	SD00002	SD00002		SD00002		SD00002		SD00002			
	9908370	9908370	9908370	9908370	9908370	9908370	9908370	9908370	9908370	9912550	9912550

SCOOTER 50cc

SCOOTER 50cc

TOP
- performances -



BSV	CPI	CPI	CPI
DIO ZX	ARAGON	HUSSAR	OLIVER
94-96	03-03	03-03	03-03
50cc 2T AC	50cc 2T AC	50cc 2T AC	50cc 2T AC
Motore Honda	Tipo Keeway	Tipo Keeway	Tipo Keeway

IT	EN	FR				
ALBERO MESSA IN MOTO	KICK SHAFT	ARBRE DE DEMARREUR				
ALBERO MOTORE Con Cuscinetti e Paraoli	CRANKSHAFT with bearings and oil seals	VILEBREQUIN doté de Paliers et Joints d'huile				
ALBERO MOTORE Senza Cuscinetti e Paraoli	CRANKSHAFT without bearings and oil seals	VILEBREQUIN sans Paliers et Joints d'huile				
BIELLA	CONROD	BIELLE				
CAMPANA FRIZIONE	CLUTCH HOUSING	CLOCHE EMBRAYAGE				
CENTRALINA AD ANTICIPO FISSO	DIGITAL IGNITION UNIT	ALLUMAGE Fixe				
CENTRALINA AD ANTICIPO VARIABILE 4T	IGNITION UNIT Variable	ALLUMAGE Numérique				
CINGHIA DI TRASMISSIONE TOP	TRANSMISSION BELT TOP PERFORMANCES	COURROIE DE TRANSMISSION TOP PERFORMANCES		9913280	9913280	9913280
CINGHIA DI TRASMISSIONE Mitsubishi	TRANSMISSION BELT Mitsubishi	COURROIE DE TRANSMISSION Mitsubishi		9935800	9935800	9935800
COLLETTORE ASPIRAZIONE	INLET MANIFOLD	COLLECTEUR ASPIRATION				
FRIZIONE CENTRIFUGA Interno Ø 105	CENTRIFUGAL CLUTCH Ø 105	EMBAYAGE CENTRIFUGE Ø 105				
FRIZIONE CENTRIFUGA Interno Ø 107	CENTRIFUGAL CLUTCH Ø 107	EMBAYAGE CENTRIFUGE Ø 107		9910020	9925130	9925130
GANASCE FRENO	BRAKE SHOES	MÂCHOIRES FREIN				
GRUPPO TERMICO Ø Standard c/testa	CYLINDER KIT Ø standard with head	CYLINDRE COMPLET Ø Standard avec culasse		9925650	9925650	9925650
GRUPPO TERMICO Ø Standard s/testa	CYLINDER KIT Ø standard without head	CYLINDRE COMPLET Ø Standard sans culasse		KT00129	KT00129	KT00129
GRUPPO TERMICO Ø Magg. c/testa	CYLINDER KIT BIG BORE with head	CYLINDRE COMPLET Ø Majoré avec culasse		9924890 KT00128	9924890 KT00128	9924890 KT00128
GRUPPO TERMICO Ø Magg. s/testa	CYLINDER KIT BIG BORE without head	CYLINDRE COMPLET Ø Majoré sans culasse				
GRUPPO TERMICO Modifica da AC a LC	CYLINDER KIT Conversion AC to LC	CYLINDRE COMPLET Modification de AC à LC				
KIT CUSCINETTI DA BANCO	BEARINGS KIT	KIT PALIERS DE VILEBREQUIN				
KIT REVISIONE POMPA ACQUA	WATER PUMP REPAIR KIT	KIT RÉVISION POMPE À EAU				
MEMBRANA CARBURATORE	CARBURETOR DIAPHRAGM	MEMBRANE CARBURATEUR				
MOTORINO D'AVVIAMENTO	STARTER ENGINE	DÉMARREUR ÉLECTRIQUE				
PULEGGIA FISSA	VARIATOR SHEAVE FIXED	POULIE FIXE				
RAPPORTI ALLUNGATI Primari	GEARS KIT Primary	RAPPORTS ALLONGÉS Primaires				
RAPPORTI ALLUNGATI Secondari	GEARS KIT Secondary	RAPPORTS ALLONGÉS Secondaires				
REGOLATORE DI TENSIONE	RECTIFIER	RÉGULATEUR DE TENSION				
RUOTA LIBERA	STARTER CLUTCH	ROUE LIBRE				
STATORE	STATOR	STATOR				
VALVOLE LAMELLARI	REED VALVE	CLAPET À LAMELLES		9912550		

CPI	DERBI	DERBI	DERBI	DERBI	DERBI	DERBI	DERBI	DERBI	DERBI	DERBI	DERBI
POP CORN	ATLANTIS	ATLANTIS 2T	ATLANTIS 2T EU2	ATLANTIS 4T	ATLANTIS 4T EU2	ATLANTIS 02	ATLANTIS 02 BULLET	ATLANTIS 02 CITY	ATLANTIS 02 RED BULLET	ATLANTIS 02 TWO CHIC	BOULEVARD 2T
03-03	07-09	10-10	07-09	04-06	07-07	02-02	03-05	04-06	03-03	05-05	09-14
50cc 2T AC	50cc 2T AC	50cc 2T AC	50cc 2T AC	50cc 4T AC	50cc 4T AC	50cc 2T AC	50cc 2T AC	50cc 2T AC	50cc 2T AC	50cc 2T AC	50cc 2T AC
Tipo Keeway		Motore Piaggio	Motore Piaggio	Motore Piaggio	Motore Piaggio	Motore Piaggio	Motore Piaggio	Motore Piaggio	Motore Piaggio	Motore Piaggio	Motore Piaggio
		CI07494	CI07494	CI07494	CI07494	CI07494	CI07494	CI07494	CI07494	CI07494	CI07494
		IM07060	IM07060			IM07060	IM07060	IM07060	IM07060	IM07060	IM07060
		IM07015	IM07015	IM07073	IM07073	IM07015	IM07015	IM07015	IM07015	IM07015	IM07015
		IM07031	IM07031			IM07031	IM07031	IM07031	IM07031	IM07031	IM07031
		9924950	9924950			9924950	9924950	9924950	9924950	9924950	9924950
9913280		9922030	9922030			9922030	9922030	9922030	9922030	9922030	
9935800		9935830	9935830	9935480	9935480	9935830	9935830	9935830	9935830	9935830	9935420
		CT00727	CT00727	CT00738	CT00737	CT00727	CT00727	CT00727	CT00727	CT00727	CT00727
9925130		9910020	9910020			9910020	9910020	9910020	9910020	9910020	9910020
9925650		9914500	9914500			9914500	9914500	9914500	9914500	9914500	9914500
KT00129		KT00080	KT00080			KT00080	KT00080	KT00080	KT00080	KT00080	KT00080
9924890 KT00128		9931250 KT00086	9931250 KT00086			9931250 KT00086	9931250 KT00086	9931250 KT00086	9931250 KT00086	9931250 KT00086	9931250 KT00086
				9925150 KT00133	9925150 KT00133						
		KK01003 KK01009	KK01003 KK01009			KK01003 KK01009	KK01003 KK01009	KK01003 KK01009	KK01003 KK01009	KK01003 KK01009	KK01003 KK01009
		MA00002	MA00002	MA00015	MA00015	MA00002	MA00002	MA00002	MA00002	MA00002	MA00002
	PL04058	PL04058	PL04058	PL04058	PL04058	PL04058	PL04058	PL04058	PL04058	PL04058	PL04058
				RE00018		RE00012					RE00012
		RL00040	RL00040	RL00039	RL00039	RL00040	RL00040	RL00040	RL00040	RL00040	RL00040
				ST00004	ST00004						
		9910930	9910930			9910930	9910930	9910930	9910930	9910930	9910930

SCOOTER 50cc

SCOOTER 50cc

TOP
- performances -



DERBI	DERBI	DERBI	DERBI
BOULEVARD 4T EU2 25KM/H	GP1	GP1	GP1 EU 2
09-09	01-02	03-03	05-05
50cc 4T AC	50cc 2T LC	50cc 2T LC	50cc 2T LC
Motore Piaggio	Motore Piaggio	Motore Piaggio	Motore Piaggio

IT	EN	FR				
ALBERO MESSA IN MOTO	KICK SHAFT	ARBRE DE DEMARREUR		CI07494	CI07494	CI07494
ALBERO MOTORE Con Cuscinetti e Paraoli	CRANKSHAFT with bearings and oil seals	VILEBREQUIN doté de Paliers et Joints d'huile			IM07060	IM07060
ALBERO MOTORE Senza Cuscinetti e Paraoli	CRANKSHAFT without bearings and oil seals	VILEBREQUIN sans Paliers et Joints d'huile		IM07073	IM07015	IM07015
BIELLA	CONROD	BIELLE			IM07031	IM07031
CAMPANA FRIZIONE	CLUTCH HOUSING	CLOCHE EMBRAYAGE			9924950	9924950
CENTRALINA AD ANTICIPO FISSO	DIGITAL IGNITION UNIT	ALLUMAGE Fixe				
CENTRALINA AD ANTICIPO VARIABILE 4T	IGNITION UNIT Variable	ALLUMAGE Numérique				
CINGHIA DI TRASMISSIONE TOP	TRANSMISSION BELT TOP PERFORMANCES	COURROIE DE TRANSMISSION TOP PERFORMANCES			9922030	9922030
CINGHIA DI TRASMISSIONE Mitsubishi	TRANSMISSION BELT Mitsubishi	COURROIE DE TRANSMISSION Mitsubishi		9935480	9935830	9935830
COLLETTORE ASPIRAZIONE	INLET MANIFOLD	COLLECTEUR ASPIRATION		CT00737	CT00727	CT00727
FRIZIONE CENTRIFUGA Interno Ø 105	CENTRIFUGAL CLUTCH Ø 105	EMBAYAGE CENTRIFUGE Ø 105				
FRIZIONE CENTRIFUGA Interno Ø 107	CENTRIFUGAL CLUTCH Ø 107	EMBAYAGE CENTRIFUGE Ø 107			9910020	9910020
GANASCE FRENO	BRAKE SHOES	MÂCHOIRES FREIN				
GRUPPO TERMICO Ø Standard c/testa	CYLINDER KIT Ø standard with head	CYLINDRE COMPLET Ø Standard avec culasse			9916580 KT00112	9916580 KT00112
GRUPPO TERMICO Ø Standard s/testa	CYLINDER KIT Ø standard without head	CYLINDRE COMPLET Ø Standard sans culasse				
GRUPPO TERMICO Ø Magg. c/testa	CYLINDER KIT BIG BORE with head	CYLINDRE COMPLET Ø Majoré avec culasse			9931270 KT00097	9931270 KT00097
GRUPPO TERMICO Ø Magg. s/testa	CYLINDER KIT BIG BORE without head	CYLINDRE COMPLET Ø Majoré sans culasse			9925150 KT00133	
GRUPPO TERMICO Modifica da AC a LC	CYLINDER KIT Conversion AC to LC	CYLINDRE COMPLET Modification de AC à LC				
KIT CUSCINETTI DA BANCO	BEARINGS KIT	KIT PALIERS DE VILEBREQUIN			KK01003 KK01009	KK01003 KK01009
KIT REVISIONE POMPA ACQUA	WATER PUMP REPAIR KIT	KIT RÉVISION POMPE À EAU			AA00796	AA00796
MEMBRANA CARBURATORE	CARBURETOR DIAPHRAGM	MEMBRANE CARBURATEUR				
MOTORINO D'AVVIAMENTO	STARTER ENGINE	DÉMARREUR ÉLECTRIQUE		MA00015	MA00002	MA00002
PULEGGIA FISSA	VARIATOR SHEAVE FIXED	POULIE FIXE		PL04058	PL04058	PL04058
RAPPORTI ALLUNGATI Primari	GÉARS KIT Primary	RAPPORTS ALLONGÉS Primaires				
RAPPORTI ALLUNGATI Secondari	GÉARS KIT Secondary	RAPPORTS ALLONGÉS Secondaires				
REGOLATORE DI TENSIONE	RECTIFIER	RÉGULATEUR DE TENSION		RE00018	RE00012	RE00012
RUOTA LIBERA	STARTER CLUTCH	ROUE LIBRE		RL00039	RL00040	RL00040
STATORE	STATOR	STATOR		ST00004		
VALVOLE LAMELLARI	REED VALVE	CLAPET À LAMELLES			9910930	9910930

DERBI	DERBI	DERBI	DERBI	EXPLORER	GARELLI	GARELLI	GARELLI	GARELLI	GARELLI	GARELLI	GARELLI
GP1 OPEN EU2	GP1 RACE EU2	SONAR 2T	VARIANT SPORT 2T	CRACKER	CAPRI LX	CAPRI LX	CICLONE	CICLONE	FLEXI	NEW VIP	TIESSE 2T
06-09	05-07	09-09	12-12	03-03	06-07	08-08	06-07	08-08	08-11	06-07	08-08
50cc 2T LC	50cc 2T LC	50cc 2T AC	50cc 2T AC	50cc 2T AC	50cc 4T AC	50cc 4T AC	50cc 4T AC	50cc 4T AC	50cc 4T AC	50cc 4T AC	50cc 2T AC
Motore Piaggio	Motore Piaggio	Motore Piaggio	Motore Piaggio	Tipo Keeway		Tipo Kymco		Tipo Kymco	Tipo Kymco		
CI07494	CI07494	CI07494									
IM07060	IM07060	IM07060									
IM07015	IM07015	IM07015									
IM07031	IM07031	IM07031									
9924950	9924950	9924950									
9922030	9922030			9913280							9913280
9935830	9935830	9935420	9935420	9935800							9935800
CT00727	CT00727	CT00727									
9910020	9910020	9910020									
9916580 KT00112	9916580 KT00112	9914500 KT00080		9925650 KT00129							
9931270 KT00097	9931270 KT00097	9931250 KT00086		9924890 KT00128							
					9925140 KT00132	9925140 KT00132	9925140 KT00132	9925140 KT00132	9925140 KT00132	9925140 KT00132	9925140 KT00132
KK01003 KK01009	KK01003 KK01009	KK01003 KK01009									
AA00796	AA00796										
MA00002	MA00002	MA00002									
PL04058	PL04058	PL04058	PL04058								
RE00012	RE00012	RE00012									
RL00040	RL00040	RL00040									
9910930	9910930	9910930									

SCOOTER 50cc

TOP
- performances -



GARELLI	GARELLI	GILERA	GILERA
TIESSE 4T	VIP	DNA	DNA
08-10	06-06	00-02	05-07
50cc 4T AC	50cc 4T AC	50cc 2T LC	50cc 2T LC
Tipo Kymco	Tipo Kymco	Motore Piaggio	Motore Piaggio

IT	EN	FR					
ALBERO MESSA IN MOTO	KICK SHAFT	ARBRE DE DEMARREUR				CI07494	CI07494
ALBERO MOTORE Con Cuscinetti e Paraoli	CRANKSHAFT with bearings and oil seals	VILEBREQUIN doté de Paliers et Joints d'huile				IM07060	IM07060
ALBERO MOTORE Senza Cuscinetti e Paraoli	CRANKSHAFT without bearings and oil seals	VILEBREQUIN sans Paliers et Joints d'huile				IM07015	IM07015
BIELLA	CONROD	BIELLE				IM07031	IM07031
CAMPANA FRIZIONE	CLUTCH HOUSING	CLOCHE EMBRAYAGE				9924950	9924950
CENTRALINA AD ANTICIPO FISSO	DIGITAL IGNITION UNIT	ALLUMAGE Fixe				9924870	
CENTRALINA AD ANTICIPO VARIABILE 4T	IGNITION UNIT Variable	ALLUMAGE Numérique					
CINGHIA DI TRASMISSIONE TOP	TRANSMISSION BELT TOP PERFORMANCES	COURROIE DE TRANSMISSION TOP PERFORMANCES			9913280		
CINGHIA DI TRASMISSIONE Mitsubishi	TRANSMISSION BELT Mitsubishi	COURROIE DE TRANSMISSION Mitsubishi			9935800	9935420	9935420
COLLETTORE ASPIRAZIONE	INLET MANIFOLD	COLLECTEUR ASPIRATION				CT00727	CT00727
FRIZIONE CENTRIFUGA Interno Ø 105	CENTRIFUGAL CLUTCH Ø 105	EMBAYAGE CENTRIFUGE Ø 105					
FRIZIONE CENTRIFUGA Interno Ø 107	CENTRIFUGAL CLUTCH Ø 107	EMBAYAGE CENTRIFUGE Ø 107				9910020	9910020
GANASCE FRENO	BRAKE SHOES	MÂCHOIRES FREIN					
GRUPPO TERMICO Ø Standard c/testa	CYLINDER KIT Ø standard with head	CYLINDRE COMPLET Ø Standard avec culasse				9916580 KT00112	9916580 KT00112
GRUPPO TERMICO Ø Standard s/testa	CYLINDER KIT Ø standard without head	CYLINDRE COMPLET Ø Standard sans culasse					
GRUPPO TERMICO Ø Magg. c/testa	CYLINDER KIT BIG BORE with head	CYLINDRE COMPLET Ø Majoré avec culasse				9931270 KT00097	9931270 KT00097
GRUPPO TERMICO Ø Magg. s/testa	CYLINDER KIT BIG BORE without head	CYLINDRE COMPLET Ø Majoré sans culasse			9925140 KT00132	9925140 KT00132	
GRUPPO TERMICO Modifica da AC a LC	CYLINDER KIT Conversion AC to LC	CYLINDRE COMPLET Modification de AC à LC					
KIT CUSCINETTI DA BANCO	BEARINGS KIT	KIT PALIERS DE VILEBREQUIN				KK01003 KK01009	KK01003 KK01009
KIT REVISIONE POMPA ACQUA	WATER PUMP REPAIR KIT	KIT RÉVISION POMPE À EAU				AA00796	AA00796
MEMBRANA CARBURATORE	CARBURETOR DIAPHRAGM	MEMBRANE CARBURATEUR					
MOTORINO D'AVVIAMENTO	STARTER ENGINE	DÉMARREUR ÉLECTRIQUE				MA00002	MA00002
PULEGGIA FISSA	VARIATOR SHEAVE FIXED	POULIE FIXE				PL04058	PL04058
RAPPORTI ALLUNGATI Primari	GÉARS KIT Primary	RAPPORTS ALLONGÉS Primaires					
RAPPORTI ALLUNGATI Secondari	GÉARS KIT Secondary	RAPPORTS ALLONGÉS Secondaires					
REGOLATORE DI TENSIONE	RECTIFIER	RÉGULATEUR DE TENSION				RE00012	RE00012
RUOTA LIBERA	STARTER CLUTCH	ROUE LIBRE				RL00040	RL00040
STATORE	STATOR	STATOR					
VALVOLE LAMELLARI	REED VALVE	CLAPET À LAMELLES				9910930	9910930

GILERA	GILERA	GILERA	GILERA	GILERA	GILERA	GILERA	GILERA	GILERA	GILERA	GILERA	GILERA
DNA GP EXPERIENCE	EASY MOVING	ICE	ICE	RUNNER	RUNNER POGGIALI	RUNNER PURE JET	RUNNER PURE JET	RUNNER PURE JET	RUNNER PURE JET	RUNNER PURE JET ST	RUNNER SP
03-04	95-96	01-05	01-05	97-00	02-02	02-04	05-06	07-07	10-11	08-08	02-04
50cc 2T LC	50cc 2T AC	50cc 2T	50cc 2T AC	50cc 2T LC	50cc 2T LC	50cc 2T-IE LC	50cc 2T-IE LC	50cc 2T-IE LC	50cc 2T-IE LC	50cc 2T-IE LC	50cc 2T LC
Motore Piaggio	Motore Piaggio	Motore Piaggio	Motore Piaggio	Motore Piaggio	Motore Piaggio	Motore Piaggio	Motore Piaggio	Motore Piaggio	Motore Piaggio	Motore Piaggio	Motore Piaggio
CI07494	CI07494		CI07494	CI07494	CI07494						CI07494
IM07060	IM07060		IM07060	IM07060	IM07060						IM07060
IM07015	IM07015		IM07015	IM07015	IM07015	IM07064	IM07064	IM07064	IM07064	IM07064	IM07015
IM07031	IM07031		IM07031	IM07031	IM07031						IM07031
9924950	9924950		9924950	9924950	9924950	9924950	9924950	9924950	9924950	9924950	9924950
9924870	9924870		9924870	9924870	9924870						9924870
	9913350		9922030	9922030		9922030					9922030
9935420	9935810		9935830	9935830	9935830	9935830					9935830
CT00727	CT00727		CT00727	CT00727	CT00727						CT00727
9910020	9910020		9910020	9910020	9910020						9910020
		CP00240									
9916580 KT00112	9914500 KT00080		9914500 KT00080	9916580 KT00112	9916580 KT00112	9916580	9916580	9916580	9916580	9916580	9916580 KT00112
9931270 KT00097	9931250 KT00086		9931250 KT00086	9931270 KT00097	9931270 KT00097	9931270	9931270	9931270	9931270	9931270	9931270 KT00097
KK01003 KK01009	KK01003 KK01009		KK01003 KK01009	KK01003 KK01009	KK01003 KK01009	KK01003 KK01009	KK01003 KK01009	KK01003 KK01009	KK01003 KK01009	KK01003 KK01009	KK01003 KK01009
AA00796				AA00796	AA00796	AA00796	AA00796	AA00796	AA00796	AA00796	AA00796
MA00002	MA00002		MA00002	MA00002	MA00002	MA00015	MA00015	MA00015	MA00015	MA00015	MA00002
PL04058	PL04058		PL04058	PL04058	PL04058	PL04058	PL04058	PL04058	PL04058	PL04058	PL04058
RE00012			RE00012	RE00012	RE00012						RE00012
RL00040	RL00040		RL00040	RL00040	RL00040	RL00039	RL00039	RL00039	RL00039	RL00039	RL00040
9910930	9910930		9910930	9910930	9910930	9910930	9910930	9910930	9910930	9910930	9910930

SCOOTER 50cc

SCOOTER 50cc

TOP
- performances -



GILERA	GILERA	GILERA	GILERA
RUNNER SP	RUNNER SP	RUNNER SP	RUNNER SP SPECIAL EDITION
05-06	07-07	10-12	07-07
50cc 2T LC	50cc 2T LC	50cc 2T LC	50cc 2T LC
Motore Piaggio	Motore Piaggio	Motore Piaggio	Motore Piaggio

IT	EN	FR				
ALBERO MESSA IN MOTO	KICK SHAFT	ARBRE DE DEMARREUR		CI07494	CI07494	CI07494
ALBERO MOTORE Con Cuscinetti e Paraoli	CRANKSHAFT with bearings and oil seals	VILEBREQUIN doté de Paliers et Joints d'huile		IM07060	IM07060	IM07060
ALBERO MOTORE Senza Cuscinetti e Paraoli	CRANKSHAFT without bearings and oil seals	VILEBREQUIN sans Paliers et Joints d'huile		IM07015	IM07015	IM07015
BIELLA	CONROD	BIELLE		IM07031	IM07031	IM07031
CAMPANA FRIZIONE	CLUTCH HOUSING	CLOCHE EMBRAYAGE		9924950	9924950	9924950
CENTRALINA AD ANTICIPO FISSO	DIGITAL IGNITION UNIT	ALLUMAGE Fixe				
CENTRALINA AD ANTICIPO VARIABILE 4T	IGNITION UNIT Variable	ALLUMAGE Numérique				
CINGHIA DI TRASMISSIONE TOP	TRANSMISSION BELT TOP PERFORMANCES	COURROIE DE TRANSMISSION TOP PERFORMANCES		9922030		
CINGHIA DI TRASMISSIONE Mitsubishi	TRANSMISSION BELT Mitsubishi	COURROIE DE TRANSMISSION Mitsubishi		9935830	9935830	9935830
COLLETTORE ASPIRAZIONE	INLET MANIFOLD	COLLECTEUR ASPIRATION		CT00727	CT00727	CT00727
FRIZIONE CENTRIFUGA Interno Ø 105	CENTRIFUGAL CLUTCH Ø 105	EMBAYAGE CENTRIFUGE Ø 105				
FRIZIONE CENTRIFUGA Interno Ø 107	CENTRIFUGAL CLUTCH Ø 107	EMBAYAGE CENTRIFUGE Ø 107		9910020	9910020	9910020
GANASCE FRENO	BRAKE SHOES	MÂCHOIRES FREIN				
GRUPPO TERMICO Ø Standard c/testa	CYLINDER KIT Ø standard with head	CYLINDRE COMPLET Ø Standard avec culasse		9916580 KT00112	9916580 KT00112	9916580 KT00112
GRUPPO TERMICO Ø Standard s/testa	CYLINDER KIT Ø standard without head	CYLINDRE COMPLET Ø Standard sans culasse				
GRUPPO TERMICO Ø Magg. c/testa	CYLINDER KIT BIG BORE with head	CYLINDRE COMPLET Ø Majoré avec culasse		9931270 KT00097	9931270 KT00097	9931270 KT00097
GRUPPO TERMICO Ø Magg. s/testa	CYLINDER KIT BIG BORE without head	CYLINDRE COMPLET Ø Majoré sans culasse				
GRUPPO TERMICO Modifica da AC a LC	CYLINDER KIT Conversion AC to LC	CYLINDRE COMPLET Modification de AC à LC				
KIT CUSCINETTI DA BANCO	BEARINGS KIT	KIT PALIERS DE VILEBREQUIN		KK01003 KK01009	KK01003 KK01009	KK01003 KK01009
KIT REVISIONE POMPA ACQUA	WATER PUMP REPAIR KIT	KIT RÉVISION POMPE À EAU		AA00796	AA00796	AA00796
MEMBRANA CARBURATORE	CARBURETOR DIAPHRAGM	MEMBRANE CARBURATEUR				
MOTORINO D'AVVIAMENTO	STARTER ENGINE	DÉMARREUR ÉLECTRIQUE		MA00002	MA00002	MA00002
PULEGGIA FISSA	VARIATOR SHEAVE FIXED	POULIE FIXE		PL04058	PL04058	PL04058
RAPPORTI ALLUNGATI Primari	GÉARS KIT Primary	RAPPORTS ALLONGÉS Primaires				
RAPPORTI ALLUNGATI Secondari	GÉARS KIT Secondary	RAPPORTS ALLONGÉS Secondaires				
REGOLATORE DI TENSIONE	RECTIFIER	RÉGULATEUR DE TENSION		RE00012	RE00012	RE00012
RUOTA LIBERA	STARTER CLUTCH	ROUE LIBRE		RL00040	RL00040	RL00040
STATORE	STATOR	STATOR				
VALVOLE LAMELLARI	REED VALVE	CLAPET À LAMELLES		9910930	9910930	9910930

GILERA	GILERA	GILERA	GILERA	GILERA	GILERA	GILERA	GILERA	GILERA	GILERA	GILERA	GILERA
RUNNER SP ST & SIMONCELLI	STALKER	STALKER	STALKER	STALKER	STALKER NAKED	STALKER SPECIAL EDITION	STORM	STORM EURO 2	TYPHOON	TYPHOON X	TYPHOON XR
08-09	97-04	05-06	07-08	09-11	08-08	07-08	94-95	07-07	94-97	98-99	00-00
50cc 2T LC	50cc 2T AC	50cc 2T AC	50cc 2T AC	50cc 2T AC	50cc 2T AC	50cc 2T AC	50cc 2T AC	50cc 2T AC	50cc 2T AC	50cc 2T AC	50cc 2T
Motore Piaggio	Motore Piaggio	Motore Piaggio	Motore Piaggio	Motore Piaggio	Motore Piaggio	Motore Piaggio	Motore Piaggio	Motore Piaggio	Motore Piaggio	Motore Piaggio	Motore Piaggio
CI07494	CI07494	CI07494	CI07494	CI07494	CI07494	CI07494	CI07494	CI07494	CI07494	CI07494	
IM07060	IM07060	IM07060	IM07060	IM07060	IM07060	IM07060	IM07060	IM07060	IM07060	IM07060	
IM07015	IM07015	IM07015	IM07015	IM07015	IM07015	IM07015	IM07015	IM07015	IM07015	IM07015	
IM07031	IM07031	IM07031	IM07031	IM07031	IM07031	IM07031	IM07031	IM07031	IM07031	IM07031	
9924950	9924950	9924950	9924950	9924950	9924950	9924950	9924950	9924950	9924950	9924950	
	9924870						9924870		9924870	9924870	
	9922030	9922030	9922030	9922030	9922030	9922030	9913280	9922030	9913280	9913280	
9935830	9935830	9935830	9935830	9935830	9935830	9935830	9935800	9935830	9935800	9935800	
CT00727	CT00727	CT00727	CT00727	CT00727	CT00727	CT00727	CT00727	CT00727	CT00727	CT00727	
9910020	9910020	9910020	9910020	9910020	9910020	9910020	9910020	9910020	9910020	9910020	
											CP00242
9916580 KT00112	9914500	9914500	9914500	9914500	9914500	9914500	9914500	9914500	9914500	9914500	
	KT00080	KT00080	KT00080	KT00080	KT00080	KT00080	KT00080	KT00080	KT00080	KT00080	
9931270 KT00097	9931250 KT00086	9931250 KT00086	9931250 KT00086	9931250 KT00086	9931250 KT00086	9931250 KT00086	9931250 KT00086	9931250 KT00086	9931250 KT00086	9931250 KT00086	
KK01003 KK01009	KK01003 KK01009	KK01003 KK01009	KK01003 KK01009	KK01003 KK01009	KK01003 KK01009	KK01003 KK01009	KK01003 KK01009	KK01003 KK01009	KK01003 KK01009	KK01003 KK01009	
AA00796											
MA00002	MA00002	MA00002	MA00002	MA00002	MA00002	MA00002	MA00002	MA00002	MA00002	MA00002	
PL04058	PL04058	PL04058	PL04058	PL04058	PL04058	PL04058	PL04058	PL04058	PL04058	PL04058	
RE00012	RE00012	RE00012	RE00012	RE00012	RE00012	RE00012		RE00012		RE00012	
RL00040	RL00040	RL00040	RL00040	RL00040	RL00040	RL00040	RL00040	RL00040	RL00040	RL00040	
9910930	9910930	9910930	9910930	9910930	9910930	9910930	9910930	9910930	9910930	9910930	

SCOOTER 50cc

SCOOTER 50cc

TOP
- performances -



GILERA	HONDA	HONDA	HONDA
TYPHOON XR	BALI	CAMINO PX	DIO SR
00-00	93-99	70-80	92-00
50cc 2T AC	50cc 2T AC	50cc 2T AC	50cc 2T AC
Motore Piaggio	Motore Honda	Honda	Motore Honda

IT	EN	FR					
ALBERO MESSA IN MOTO	KICK SHAFT	ARBRE DE DEMARREUR		CI07494			
ALBERO MOTORE Con Cuscinetti e Paraoli	CRANKSHAFT with bearings and oil seals	VILEBREQUIN doté de Paliers et Joints d'huile		IM07060			
ALBERO MOTORE Senza Cuscinetti e Paraoli	CRANKSHAFT without bearings and oil seals	VILEBREQUIN sans Paliers et Joints d'huile		IM07015			
BIELLA	CONROD	BIELLE		IM07031			
CAMPANA FRIZIONE	CLUTCH HOUSING	CLOCHE EMBRAYAGE		9924950			
CENTRALINA AD ANTICIPO FISSO	DIGITAL IGNITION UNIT	ALLUMAGE Fixe		9924870			
CENTRALINA AD ANTICIPO VARIABILE 4T	IGNITION UNIT Variable	ALLUMAGE Numérique					
CINGHIA DI TRASMISSIONE TOP	TRANSMISSION BELT TOP PERFORMANCES	COURROIE DE TRANSMISSION TOP PERFORMANCES		9922030			
CINGHIA DI TRASMISSIONE Mitsubishi	TRANSMISSION BELT Mitsubishi	COURROIE DE TRANSMISSION Mitsubishi		9935830	9935240		
COLLETTORE ASPIRAZIONE	INLET MANIFOLD	COLLECTEUR ASPIRATION		CT00727			
FRIZIONE CENTRIFUGA Interno Ø 105	CENTRIFUGAL CLUTCH Ø 105	EMBAYAGE CENTRIFUGE Ø 105					
FRIZIONE CENTRIFUGA Interno Ø 107	CENTRIFUGAL CLUTCH Ø 107	EMBAYAGE CENTRIFUGE Ø 107			9910020		
GANASCE FRENO	BRAKE SHOES	MÂCHOIRES FREIN					
GRUPPO TERMICO Ø Standard c/testa	CYLINDER KIT Ø standard with head	CYLINDRE COMPLET Ø Standard avec culasse		9914500			
GRUPPO TERMICO Ø Standard s/testa	CYLINDER KIT Ø standard without head	CYLINDRE COMPLET Ø Standard sans culasse		KT00080	KT00113		
GRUPPO TERMICO Ø Magg. c/testa	CYLINDER KIT BIG BORE with head	CYLINDRE COMPLET Ø Majoré avec culasse		9931250 KT00086			
GRUPPO TERMICO Ø Magg. s/testa	CYLINDER KIT BIG BORE without head	CYLINDRE COMPLET Ø Majoré sans culasse			KT00090	KT00048	
GRUPPO TERMICO Modifica da AC a LC	CYLINDER KIT Conversion AC to LC	CYLINDRE COMPLET Modification de AC à LC					
KIT CUSCINETTI DA BANCO	BEARINGS KIT	KIT PALIERS DE VILEBREQUIN		KK01003 KK01009			
KIT REVISIONE POMPA ACQUA	WATER PUMP REPAIR KIT	KIT RÉVISION POMPE À EAU					
MEMBRANA CARBURATORE	CARBURETOR DIAPHRAGM	MEMBRANE CARBURATEUR					
MOTORINO D'AVVIAMENTO	STARTER ENGINE	DÉMARREUR ÉLECTRIQUE		MA00002			
PULEGGIA FISSA	VARIATOR SHEAVE FIXED	POULIE FIXE		PL04058			
RAPPORTI ALLUNGATI Primari	GÉARS KIT Primary	RAPPORTS ALLONGÉS Primaires					
RAPPORTI ALLUNGATI Secondari	GÉARS KIT Secondary	RAPPORTS ALLONGÉS Secondaires					
REGOLATORE DI TENSIONE	RECTIFIER	RÉGULATEUR DE TENSION		RE00012			
RUOTA LIBERA	STARTER CLUTCH	ROUE LIBRE		RL00040			
STATORE	STATOR	STATOR					
VALVOLE LAMELLARI	REED VALVE	CLAPET À LAMELLES		9910930	9912550	9912550	

HONDA	HONDA	HONDA	HONDA	HONDA	HONDA	HONDA	HONDA	HONDA	HONDA	HONDA	HONDA
DIO ZX	LEAD	MET IN	SFX / SXR	SGX SKY	SH	SH NEW	SHADOW	VISION	WALLAROO	X8R S	X8R X
94-96	89-90	90-92	95-01	97-04	84-89	96-01	98-01	88-95	90-01	98-01	98-01
50cc 2T AC	50cc 2T AC	50cc 2T AC	50cc 2T AC	50cc 2T AC	50cc 2T AC	50cc 2T AC	50cc 2T AC	50cc 2T AC	50cc 2T AC	50cc 2T AC	50cc 2T AC
Motore Honda	Motore Honda	Motore Honda	Motore Honda	Motore Honda	Motore Honda	Motore Honda	Motore Honda	Motore Honda	Motore Honda	Motore Honda	Motore Honda
								9931580			
	9935860		9935240		9935850		9935240				
9910020			9910020	9910020		9910020					
			KT00113	KT00113		KT00113				KT00113	KT00113
			KT00090	KT00090		KT00090			KT00073	KT00090	KT00090
9912550	9912550	9912550	9912550	9912550	9912550	9912550	9912550	9912550		9912550	9912550

SCOOTER 50cc

SCOOTER 50cc

TOP
- performances -



HSC	HSC	HUPPER	HUPPER
SC 01	SC 01 L	MONTECARLO 30	MONTECARLO 30
94-96	94-96	09-09	11-11
50cc 2T AC	50cc 2T AC	50cc 2T AC	50cc 4T AC
Motore Honda	Motore Honda		Tipo Kymco

IT	EN	FR				
ALBERO MESSA IN MOTO	KICK SHAFT	ARBRE DE DEMARREUR				
ALBERO MOTORE Con Cuscinetti e Paraoli	CRANKSHAFT with bearings and oil seals	VILEBREQUIN doté de Paliers et Joints d'huile				
ALBERO MOTORE Senza Cuscinetti e Paraoli	CRANKSHAFT without bearings and oil seals	VILEBREQUIN sans Paliers et Joints d'huile				
BIELLA	CONROD	BIELLE				
CAMPANA FRIZIONE	CLUTCH HOUSING	CLOCHE EMBRAYAGE				
CENTRALINA AD ANTICIPO FISSO	DIGITAL IGNITION UNIT	ALLUMAGE Fixe				
CENTRALINA AD ANTICIPO VARIABILE 4T	IGNITION UNIT Variable	ALLUMAGE Numérique				
CINGHIA DI TRASMISSIONE TOP	TRANSMISSION BELT TOP PERFORMANCES	COURROIE DE TRANSMISSION TOP PERFORMANCES				9913280
CINGHIA DI TRASMISSIONE Mitsubishi	TRANSMISSION BELT Mitsubishi	COURROIE DE TRANSMISSION Mitsubishi				
COLLETTORE ASPIRAZIONE	INLET MANIFOLD	COLLECTEUR ASPIRATION				
FRIZIONE CENTRIFUGA Interno Ø 105	CENTRIFUGAL CLUTCH Ø 105	EMBAYAGE CENTRIFUGE Ø 105				
FRIZIONE CENTRIFUGA Interno Ø 107	CENTRIFUGAL CLUTCH Ø 107	EMBAYAGE CENTRIFUGE Ø 107		9910020	9910020	
GANASCE FRENO	BRAKE SHOES	MÂCHOIRES FREIN				
GRUPPO TERMICO Ø Standard c/testa	CYLINDER KIT Ø standard with head	CYLINDRE COMPLET Ø Standard avec culasse				
GRUPPO TERMICO Ø Standard s/testa	CYLINDER KIT Ø standard without head	CYLINDRE COMPLET Ø Standard sans culasse				
GRUPPO TERMICO Ø Magg. c/testa	CYLINDER KIT BIG BORE with head	CYLINDRE COMPLET Ø Majoré avec culasse				
GRUPPO TERMICO Ø Magg. s/testa	CYLINDER KIT BIG BORE without head	CYLINDRE COMPLET Ø Majoré sans culasse				9925140 KT00132
GRUPPO TERMICO Modifica da AC a LC	CYLINDER KIT Conversion AC to LC	CYLINDRE COMPLET Modification de AC à LC				
KIT CUSCINETTI DA BANCO	BEARINGS KIT	KIT PALIERS DE VILEBREQUIN				
KIT REVISIONE POMPA ACQUA	WATER PUMP REPAIR KIT	KIT RÉVISION POMPE À EAU				
MEMBRANA CARBURATORE	CARBURETOR DIAPHRAGM	MEMBRANE CARBURATEUR				
MOTORINO D'AVVIAMENTO	STARTER ENGINE	DÉMARREUR ÉLECTRIQUE				
PULEGGIA FISSA	VARIATOR SHEAVE FIXED	POULIE FIXE				
RAPPORTI ALLUNGATI Primari	GÉARS KIT Primary	RAPPORTS ALLONGÉS Primaires				
RAPPORTI ALLUNGATI Secondari	GÉARS KIT Secondary	RAPPORTS ALLONGÉS Secondaires				
REGOLATORE DI TENSIONE	RECTIFIER	RÉGULATEUR DE TENSION				
RUOTA LIBERA	STARTER CLUTCH	ROUE LIBRE				
STATORE	STATOR	STATOR				
VALVOLE LAMELLARI	REED VALVE	CLAPET À LAMELLES		9912550	9912550	

HYOSUNG	HYOSUNG	HYOSUNG	HYOSUNG	HYOSUNG	HYOSUNG	ITALJET	ITALJET	ITALJET	ITALJET	ITALJET	ITALJET
SD SENSE EU1	SD SENSE EU2	SF B RALLY	SF FAST	SF FAST EU2	SF R RALLY	BAZOOKA	DRAGSTER	FORMULA	JET SET	PISTA	PISTA 2
00-01	05-05	04-08	00-00	01-03	04-08	91-94	98-02	94-97	02-02	92-97	97-98
50cc 2T AC	50cc 2T AC	50cc 2T AC	50cc 2T AC	50cc 2T AC	50cc 2T AC	50cc 2T AC	50cc 2T LC	50cc 2T AC	50cc 2T AC	50cc 2T AC	50cc 2T AC
Tipo Suzuki	Tipo Suzuki	Tipo Suzuki	Tipo Suzuki	Tipo Suzuki	Tipo Suzuki	Tipo CW	MA	Motore Morini	Motore Piaggio	Tipo CW	Tipo CW
							CI07487				CI07487
							IM07059	IM07060			
							IM07014	IM07015			
							IM07032	IM07031			
							9924940	9924950			
							9910100	9924870			
							9907770	9922030			9907770
							9935270				9935270
							CT00725	CT00727			
						9911060	9911060			9911060	9911060
						9910020	9910020 9925130	9910020	9910020	9910020	9910020
							9931110	9914500			
							KT00094	KT00080			
							9931310 KT00109	9931250 KT00086			
KT00057	KT00057	KT00057	KT00057	KT00057	KT00057			KT00057			
							KK01000 KK01002	KK01003 KK01009			
							AA00788				
							MA00001				
							PL04055 PL04056				
							9913300				
							9909520				
							AA00767 RL00001				AA00767
							9908370	9910930			

SCOOTER 50cc

TOP
- performances -



ITALJET	ITALJET	ITALJET	ITALJET
SCOOOP	SCOOOP 2	TORPEDO	TORPEDO NEW
91-95	96-98	97-00	00-01
50cc 2T AC	50cc 2T AC	50cc 4T AC	50cc 2T AC
Tipo CW	Tipo CW	Motore Piaggio	Motore Piaggio

IT	EN	FR				
ALBERO MESSA IN MOTO	KICK SHAFT	ARBRE DE DEMARREUR			CI07487	
ALBERO MOTORE Con Cuscinetti e Paraoli	CRANKSHAFT with bearings and oil seals	VILEBREQUIN doté de Paliers et Joints d'huile				IM07060
ALBERO MOTORE Senza Cuscinetti e Paraoli	CRANKSHAFT without bearings and oil seals	VILEBREQUIN sans Paliers et Joints d'huile				IM07015
BIELLA	CONROD	BIELLE				IM07031
CAMPANA FRIZIONE	CLUTCH HOUSING	CLOCHE EMBRAYAGE				9924950
CENTRALINA AD ANTICIPO FISSO	DIGITAL IGNITION UNIT	ALLUMAGE Fixe				9924870
CENTRALINA AD ANTICIPO VARIABILE 4T	IGNITION UNIT Variable	ALLUMAGE Numérique				
CINGHIA DI TRASMISSIONE TOP	TRANSMISSION BELT TOP PERFORMANCES	COURROIE DE TRANSMISSION TOP PERFORMANCES		9907770		9922030
CINGHIA DI TRASMISSIONE Mitsubishi	TRANSMISSION BELT Mitsubishi	COURROIE DE TRANSMISSION Mitsubishi		9935270		
COLLETTORE ASPIRAZIONE	INLET MANIFOLD	COLLECTEUR ASPIRATION				CT00727
FRIZIONE CENTRIFUGA Interno Ø 105	CENTRIFUGAL CLUTCH Ø 105	EMBAYAGE CENTRIFUGE Ø 105		9911060	9911060	
FRIZIONE CENTRIFUGA Interno Ø 107	CENTRIFUGAL CLUTCH Ø 107	EMBAYAGE CENTRIFUGE Ø 107		9910020	9910020	9910020
GANASCE FRENO	BRAKE SHOES	MÂCHOIRES FREIN				
GRUPPO TERMICO Ø Standard c/testa	CYLINDER KIT Ø standard with head	CYLINDRE COMPLET Ø Standard avec culasse				9914500
GRUPPO TERMICO Ø Standard s/testa	CYLINDER KIT Ø standard without head	CYLINDRE COMPLET Ø Standard sans culasse				KT00080
GRUPPO TERMICO Ø Magg. c/testa	CYLINDER KIT BIG BORE with head	CYLINDRE COMPLET Ø Majoré avec culasse				9931250 KT00086
GRUPPO TERMICO Ø Magg. s/testa	CYLINDER KIT BIG BORE without head	CYLINDRE COMPLET Ø Majoré sans culasse			9925150 KT00133	
GRUPPO TERMICO Modifica da AC a LC	CYLINDER KIT Conversion AC to LC	CYLINDRE COMPLET Modification de AC à LC				
KIT CUSCINETTI DA BANCO	BEARINGS KIT	KIT PALIERS DE VILEBREQUIN				KK01003 KK01009
KIT REVISIONE POMPA ACQUA	WATER PUMP REPAIR KIT	KIT RÉVISION POMPE À EAU				
MEMBRANA CARBURATORE	CARBURETOR DIAPHRAGM	MEMBRANE CARBURATEUR				
MOTORINO D'AVVIAMENTO	STARTER ENGINE	DÉMARREUR ÉLECTRIQUE				
PULEGGIA FISSA	VARIATOR SHEAVE FIXED	POULIE FIXE				
RAPPORTI ALLUNGATI Primari	GÉARS KIT Primary	RAPPORTS ALLONGÉS Primaires				
RAPPORTI ALLUNGATI Secondari	GÉARS KIT Secondary	RAPPORTS ALLONGÉS Secondaires				
REGOLATORE DI TENSIONE	RECTIFIER	RÉGULATEUR DE TENSION				
RUOTA LIBERA	STARTER CLUTCH	ROUE LIBRE			AA00767	
STATORE	STATOR	STATOR				
VALVOLE LAMELLARI	REED VALVE	CLAPET À LAMELLES				9910930

ITALJET	ITALJET	KEEWAY	KEEWAY	KEEWAY	KEEWAY	KEEWAY	KEEWAY	KEEWAY	KEEWAY	KEEWAY	KTM	KYMCO
VELOCIFERO	YANKEE	F-ACT	FLASH	FOCUS	GOCCIA	HURRICANE	MATRIX	PIXEL EURO 2	RY8	K50	AGILITY 4T CARRY	
98-02	93-97	07-08	07-08	06-06	09-09	06-08	06-08	09-12	08-08	96-01	11-11	
50cc 2T AC	50cc 2T AC	50cc 2T AC	50cc 2T AC	50cc 2T AC	50cc 2T AC	50cc 2T AC	50cc 2T AC	50cc 2T AC	50cc 2T AC	50cc 2T AC	50cc 4T AC	
Motore Morini	Tipo CW	Motore Keeway	Motore Keeway	Motore Keeway	Motore Keeway	Motore Keeway	Motore Keeway	Motore Keeway	Motore Keeway	MY	Motore Kymco	
	C107487									C107487		
										IM07059	IM07074	
										IM07014		
										IM07032		
										9924940		
	9907770	9913280	9913280	9913280	9913280	9913280	9913280	9913280	9913280	9907770	9931590	
	9935270	9935800	9935800	9935800	9935800	9935800	9935800	9935800	9935800	9935270		
										CT00725		
	9911060									9911060		
	9910020	9925130	9925130	9925130	9925130	9925130	9925130	9925130	9925130	9910020 9925130		
		9925650	9925650	9925650	9925650	9925650	9925650	9925650	9925650	9931140		
		KT00129	KT00129	KT00129	KT00129	KT00129	KT00129	KT00129	KT00129	KT00095		
		9924890 KT00128	9924890 KT00128	9924890 KT00128	9924890 KT00128	9924890 KT00128	9924890 KT00128	9924890 KT00128	9924890 KT00128	9931340 KT00087		
KT00057											9925140 KT00132	
										9911090		
										KK01000 KK01002		
											MC12009	
										MA00001	MA00025	
										PL04055 PL04056		
										9913300		
	AA00767									AA00767 RL00001	RL00040	
										SD00002		
										9908370		

SCOOTER 50cc

TOP
- performances -



KYMCO	KYMCO	KYMCO	KYMCO
AGILITY 4T R10	AGILITY 4T R10	AGILITY 4T R12	AGILITY PLUS 4T
06-06	07-08	07-08	14-14
50cc 4T AC	50cc 4T AC	50cc 4T AC	50cc 4T AC
Motore Kymco	Motore Kymco	Motore Kymco	Motore Kymco

IT	EN	FR				
ALBERO MESSA IN MOTO	KICK SHAFT	ARBRE DE DEMARREUR				
ALBERO MOTORE Con Cuscinetti e Paraoli	CRANKSHAFT with bearings and oil seals	VILEBREQUIN doté de Paliers et Joints d'huile		IM07074	IM07074	IM07074
ALBERO MOTORE Senza Cuscinetti e Paraoli	CRANKSHAFT without bearings and oil seals	VILEBREQUIN sans Paliers et Joints d'huile				
BIELLA	CONROD	BIELLE				
CAMPANA FRIZIONE	CLUTCH HOUSING	CLOCHE EMBRAYAGE				
CENTRALINA AD ANTICIPO FISSO	DIGITAL IGNITION UNIT	ALLUMAGE Fixe				
CENTRALINA AD ANTICIPO VARIABILE 4T	IGNITION UNIT Variable	ALLUMAGE Numérique				
CINGHIA DI TRASMISSIONE TOP	TRANSMISSION BELT TOP PERFORMANCES	COURROIE DE TRANSMISSION TOP PERFORMANCES				9931590
CINGHIA DI TRASMISSIONE Mitsubishi	TRANSMISSION BELT Mitsubishi	COURROIE DE TRANSMISSION Mitsubishi				
COLLETTORE ASPIRAZIONE	INLET MANIFOLD	COLLECTEUR ASPIRATION				CT00743
FRIZIONE CENTRIFUGA Interno Ø 105	CENTRIFUGAL CLUTCH Ø 105	EMBAYAGE CENTRIFUGE Ø 105				
FRIZIONE CENTRIFUGA Interno Ø 107	CENTRIFUGAL CLUTCH Ø 107	EMBAYAGE CENTRIFUGE Ø 107				
GANASCE FRENO	BRAKE SHOES	MÂCHOIRES FREIN				
GRUPPO TERMICO Ø Standard c/testa	CYLINDER KIT Ø standard with head	CYLINDRE COMPLET Ø Standard avec culasse				
GRUPPO TERMICO Ø Standard s/testa	CYLINDER KIT Ø standard without head	CYLINDRE COMPLET Ø Standard sans culasse				
GRUPPO TERMICO Ø Magg. c/testa	CYLINDER KIT BIG BORE with head	CYLINDRE COMPLET Ø Majoré avec culasse				
GRUPPO TERMICO Ø Magg. s/testa	CYLINDER KIT BIG BORE without head	CYLINDRE COMPLET Ø Majoré sans culasse		9925140 KT00132	9925140 KT00132	9925140 KT00132
GRUPPO TERMICO Modifica da AC a LC	CYLINDER KIT Conversion AC to LC	CYLINDRE COMPLET Modification de AC à LC				
KIT CUSCINETTI DA BANCO	BEARINGS KIT	KIT PALIERS DE VILEBREQUIN				
KIT REVISIONE POMPA ACQUA	WATER PUMP REPAIR KIT	KIT RÉVISION POMPE À EAU				
MEMBRANA CARBURATORE	CARBURETOR DIAPHRAGM	MEMBRANE CARBURATEUR		MC12009	MC12009	MC12009
MOTORINO D'AVVIAMENTO	STARTER ENGINE	DÉMARREUR ÉLECTRIQUE		MA00025	MA00025	MA00025
PULEGGIA FISSA	VARIATOR SHEAVE FIXED	POULIE FIXE				
RAPPORTI ALLUNGATI Primari	GÉARS KIT Primary	RAPPORTS ALLONGÉS Primaires				
RAPPORTI ALLUNGATI Secondari	GÉARS KIT Secondary	RAPPORTS ALLONGÉS Secondaires				
REGOLATORE DI TENSIONE	RECTIFIER	RÉGULATEUR DE TENSION		RE00013	RE00013	RE00013
RUOTA LIBERA	STARTER CLUTCH	ROUE LIBRE		RL00040	RL00040	RL00040
STATORE	STATOR	STATOR		ST00028	ST00028	ST00028
VALVOLE LAMELLARI	REED VALVE	CLAPET À LAMELLES				

KYMCO	KYMCO	KYMCO	KYMCO	KYMCO	KYMCO	KYMCO	KYMCO	KYMCO	KYMCO	KYMCO	KYMCO
AGILITY R12	AGILITY R12 ECS	AGILITY R16	AGILITY R16	AGILITY R16	AGILITY R16 2T	AGILITY R16 2T	AGILITY RS	AGILITY RS NAKED	B&W	B&W EU2	CX
05-05	16-16	08-08	09-09	12-12	10-10	12-12	09-09	10-10	02-02	03-03	93-93
50cc 4T AC	50cc 4T AC	50cc 4T AC	50cc 4T AC	50cc 4T AC	50cc 2T AC	50cc 2T AC	50cc 4T AC	50cc 2T AC	50cc 2T LC	50cc 2T LC	50cc 2T AC
Motore Kymco	Motore Kymco	Motore Kymco	Motore Kymco	Motore Kymco	Motore Kymco	Motore Kymco	Motore Kymco	Motore Kymco	Motore Kymco	Motore Kymco	Motore Kymco
IM07074	IM07074	IM07074	IM07074	IM07074			IM07074				
9931590	9931590	9931590	9931590	9931590	9931590	9931590	9931590	9931590	9931590	9931590	
CT00743		CT00743	CT00743	CT00743			CT00743				
9910020											
9925140 KT00132	9925140 KT00132	9925140 KT00132	9925140 KT00132	9925140 KT00132			9925140 KT00132				
						KK01013	KK01013		KK01013	KK01013	KK01013
MC12009		MC12009	MC12009	MC12009			MC12009				
MA00025	MA00025	MA00025	MA00025	MA00025			MA00025		MA00014	MA00014	
RE00013									RE00013	RE00013	RE00013
RL00040		RL00040	RL00040	RL00040	RL00040	RL00040	RL00040	RL00040	RL00040	RL00040	
ST00028											
											9912550

SCOOTER 50cc

SCOOTER 50cc

TOP
- performances -



KYMCO	KYMCO	KYMCO	KYMCO
CX SUPER	DINK AC	DINK LC	DINK 50 4T
94-97	98-02	98-02	07-07
50cc 2T AC	50cc 2T AC	50cc 2T LC	50cc 4T AC
Motore Kymco	Motore Kymco	Motore Kymco	Motore Kymco

IT	EN	FR				
ALBERO MESSA IN MOTO	KICK SHAFT	ARBRE DE DEMARREUR				
ALBERO MOTORE Con Cuscinetti e Paraoli	CRANKSHAFT with bearings and oil seals	VILEBREQUIN doté de Paliers et Joints d'huile				
ALBERO MOTORE Senza Cuscinetti e Paraoli	CRANKSHAFT without bearings and oil seals	VILEBREQUIN sans Paliers et Joints d'huile				
BIELLA	CONROD	BIELLE				
CAMPANA FRIZIONE	CLUTCH HOUSING	CLOCHE EMBRAYAGE				
CENTRALINA AD ANTICIPO FISSO	DIGITAL IGNITION UNIT	ALLUMAGE Fixe				
CENTRALINA AD ANTICIPO VARIABILE 4T	IGNITION UNIT Variable	ALLUMAGE Numérique				
CINGHIA DI TRASMISSIONE TOP	TRANSMISSION BELT TOP PERFORMANCES	COURROIE DE TRANSMISSION TOP PERFORMANCES			9931590	9931590
CINGHIA DI TRASMISSIONE Mitsubishi	TRANSMISSION BELT Mitsubishi	COURROIE DE TRANSMISSION Mitsubishi				9931590
COLLETTORE ASPIRAZIONE	INLET MANIFOLD	COLLECTEUR ASPIRATION				
FRIZIONE CENTRIFUGA Interno Ø 105	CENTRIFUGAL CLUTCH Ø 105	EMBAYAGE CENTRIFUGE Ø 105				
FRIZIONE CENTRIFUGA Interno Ø 107	CENTRIFUGAL CLUTCH Ø 107	EMBAYAGE CENTRIFUGE Ø 107				
GANASCE FRENO	BRAKE SHOES	MÂCHOIRES FREIN				
GRUPPO TERMICO Ø Standard c/testa	CYLINDER KIT Ø standard with head	CYLINDRE COMPLET Ø Standard avec culasse				
GRUPPO TERMICO Ø Standard s/testa	CYLINDER KIT Ø standard without head	CYLINDRE COMPLET Ø Standard sans culasse				
GRUPPO TERMICO Ø Magg. c/testa	CYLINDER KIT BIG BORE with head	CYLINDRE COMPLET Ø Majoré avec culasse				
GRUPPO TERMICO Ø Magg. s/testa	CYLINDER KIT BIG BORE without head	CYLINDRE COMPLET Ø Majoré sans culasse				9925140 KT00132
GRUPPO TERMICO Modifica da AC a LC	CYLINDER KIT Conversion AC to LC	CYLINDRE COMPLET Modification de AC à LC				
KIT CUSCINETTI DA BANCO	BEARINGS KIT	KIT PALIERS DE VILEBREQUIN				KK01013
KIT REVISIONE POMPA ACQUA	WATER PUMP REPAIR KIT	KIT RÉVISION POMPE À EAU				
MEMBRANA CARBURATORE	CARBURETOR DIAPHRAGM	MEMBRANE CARBURATEUR				MC12009
MOTORINO D'AVVIAMENTO	STARTER ENGINE	DÉMARREUR ÉLECTRIQUE			MA00014	MA00025
PULEGGIA FISSA	VARIATOR SHEAVE FIXED	POULIE FIXE				
RAPPORTI ALLUNGATI Primari	GÉARS KIT Primary	RAPPORTS ALLONGÉS Primaires				
RAPPORTI ALLUNGATI Secondari	GÉARS KIT Secondary	RAPPORTS ALLONGÉS Secondaires				
REGOLATORE DI TENSIONE	RECTIFIER	RÉGULATEUR DE TENSION		RE00013		RE00013 RE00013
RUOTA LIBERA	STARTER CLUTCH	ROUE LIBRE			RL00040	RL00040 RL00040
STATORE	STATOR	STATOR				ST00028
VALVOLE LAMELLARI	REED VALVE	CLAPET À LAMELLES		9912550		

KYMCO	KYMCO	KYMCO	KYMCO	KYMCO	KYMCO	KYMCO	KYMCO	KYMCO	KYMCO	KYMCO	KYMCO
DINK CLASSIC EU2	DJ WORLD	DJ X	DJ Y	FEVER ZX	FEVER ZX EU2	FILLY	FILLY LX	HEROISM	K 12	KB	LIKE
03-03	94-00	91-92	93-93	99-00	03-04	98-00	01-02	95-97	95-00	95-00	09-09
50cc 2T AC	50cc 2T AC	50cc 2T AC	50cc 2T AC	50cc 2T AC	50cc 2T AC	50cc 4T AC	50cc 4T AC	50cc 2T AC	50cc 2T AC	50cc 2T AC	50cc 4T AC
Motore Kymco	Motore Kymco	Motore Kymco	Motore Kymco	Motore Kymco	Motore Kymco	Motore Kymco	Motore Kymco	Motore Kymco	Motore Kymco	Motore Kymco	Motore Kymco
						IM07074	IM07074				
9931590											9931590
						CT00743	CT00743				
						9925140 KT00132	9925140 KT00132				9925140
KK01013								KK01013			
MA00014						MA00025	MA00025	MA00014			
RE00013	RE00013	RE00013	RE00013	RE00013	RE00013	RE00013	RE00013	RE00013	RE00013	RE00013	RE00013
RL00040						RL00040	RL00040	RL00040			RL00040
						ST00028	ST00028				
	9912550		9912550	9912550	9912550				9912550	9912550	

SCOOTER 50cc

SCOOTER 50cc

TOP
- performances -



KYMCO	KYMCO	KYMCO	KYMCO
LIKE	PEOPLE	PEOPLE	PEOPLE EURO 2
09-09	99-03	04-04	03-03
50cc 4T AC	50cc 2T AC	50cc 2T AC	50cc 2T AC
Motore Kymco	Motore Kymco	Motore Kymco	Motore Kymco

IT	EN	FR				
ALBERO MESSA IN MOTO	KICK SHAFT	ARBRE DE DEMARREUR				
ALBERO MOTORE Con Cuscinetti e Paraoli	CRANKSHAFT with bearings and oil seals	VILEBREQUIN doté de Paliers et Joints d'huile		IM07074		
ALBERO MOTORE Senza Cuscinetti e Paraoli	CRANKSHAFT without bearings and oil seals	VILEBREQUIN sans Paliers et Joints d'huile				
BIELLA	CONROD	BIELLE				
CAMPANA FRIZIONE	CLUTCH HOUSING	CLOCHE EMBRAYAGE				
CENTRALINA AD ANTICIPO FISSO	DIGITAL IGNITION UNIT	ALLUMAGE Fixe				
CENTRALINA AD ANTICIPO VARIABILE 4T	IGNITION UNIT Variable	ALLUMAGE Numérique				
CINGHIA DI TRASMISSIONE TOP	TRANSMISSION BELT TOP PERFORMANCES	COURROIE DE TRANSMISSION TOP PERFORMANCES		9931590	9931590	9931590
CINGHIA DI TRASMISSIONE Mitsubishi	TRANSMISSION BELT Mitsubishi	COURROIE DE TRANSMISSION Mitsubishi				
COLLETTORE ASPIRAZIONE	INLET MANIFOLD	COLLECTEUR ASPIRATION		CT00743		
FRIZIONE CENTRIFUGA Interno Ø 105	CENTRIFUGAL CLUTCH Ø 105	EMBAYAGE CENTRIFUGE Ø 105				
FRIZIONE CENTRIFUGA Interno Ø 107	CENTRIFUGAL CLUTCH Ø 107	EMBAYAGE CENTRIFUGE Ø 107				
GANASCE FRENO	BRAKE SHOES	MÂCHOIRES FREIN				
GRUPPO TERMICO Ø Standard c/testa	CYLINDER KIT Ø standard with head	CYLINDRE COMPLET Ø Standard avec culasse				
GRUPPO TERMICO Ø Standard s/testa	CYLINDER KIT Ø standard without head	CYLINDRE COMPLET Ø Standard sans culasse				
GRUPPO TERMICO Ø Magg. c/testa	CYLINDER KIT BIG BORE with head	CYLINDRE COMPLET Ø Majoré avec culasse				
GRUPPO TERMICO Ø Magg. s/testa	CYLINDER KIT BIG BORE without head	CYLINDRE COMPLET Ø Majoré sans culasse		9925140 KT00132		
GRUPPO TERMICO Modifica da AC a LC	CYLINDER KIT Conversion AC to LC	CYLINDRE COMPLET Modification de AC à LC				
KIT CUSCINETTI DA BANCO	BEARINGS KIT	KIT PALIERS DE VILEBREQUIN			KK01013	KK01013
KIT REVISIONE POMPA ACQUA	WATER PUMP REPAIR KIT	KIT RÉVISION POMPE À EAU				
MEMBRANA CARBURATORE	CARBURETOR DIAPHRAGM	MEMBRANE CARBURATEUR		MC12009		
MOTORINO D'AVVIAMENTO	STARTER ENGINE	DÉMARREUR ÉLECTRIQUE		MA00025	MA00014	MA00014
PULEGGIA FISSA	VARIATOR SHEAVE FIXED	POULIE FIXE				
RAPPORTI ALLUNGATI Primari	GÉARS KIT Primary	RAPPORTS ALLONGÉS Primaires				
RAPPORTI ALLUNGATI Secondari	GÉARS KIT Secondary	RAPPORTS ALLONGÉS Secondaires				
REGOLATORE DI TENSIONE	RECTIFIER	RÉGULATEUR DE TENSION			RE00013	RE00013
RUOTA LIBERA	STARTER CLUTCH	ROUE LIBRE		RL00040	RL00040	RL00040
STATORE	STATOR	STATOR				
VALVOLE LAMELLARI	REED VALVE	CLAPET À LAMELLES				

KYMCO	KYMCO	KYMCO	KYMCO	KYMCO	KYMCO	KYMCO	KYMCO	KYMCO	KYMCO	KYMCO	KYMCO
PEOPLE EURO 2	PEOPLE EURO 2	PEOPLE S	PEOPLE S 4T	SENTO	SNIPER	SNIPER DD	SUPER 8	SUPER 8 4T	SUPER 8 4T	SUPER 8 4T	SUPER 9
08-08	11-11	05-08	06-08	08-08	93-93	94-96	09-09	07-07	09-09	13-13	00-00
50cc 2T AC	50cc 2T AC	50cc 2T AC	50cc 4T AC	50cc 4T AC	50cc 2T AC	50cc 2T AC	50cc 2T AC	50cc 4T AC	50cc 4T AC	50cc 4T AC	50cc 2T LC
Motore Kymco	Motore Kymco	Motore Kymco	Motore Kymco	Motore Kymco	Motore Kymco	Motore Kymco	Motore Kymco	Motore Kymco	Motore Kymco	Motore Kymco	Motore Kymco
			IM07074	IM07074				IM07074	IM07074	IM07074	
9931590	9931590	9931590	9931590				9931590	9931590	9931590		9931590
			CT00743					CT00743	CT00743		
			9925140 KT00132	9925140 KT00132				9925140 KT00132	9925140 KT00132		
KK01013	KK01013	KK01013			KK01013	KK01013	KK01013				KK01013
								MC12009	MC12009	MC12009	
MA00014	MA00014	MA00014	MA00025	MA00025	MA00014	MA00014		MA00025	MA00025		MA00014
RE00013			RE00013		RE00013	RE00013					RE00013
RL00040	RL00040	RL00040	RL00040	RL00040	RL00040	RL00040	RL00040	RL00040	RL00040		RL00040
			ST00028	ST00028							

SCOOTER 50cc

TOP
- performances -



KYMCO	KYMCO	KYMCO	KYMCO
SUPER 9 EU2	SUPER 9 EU2	TOP BOY	VITALITY 2T
03-03	04-04	97-00	04-04
50cc 2T LC	50cc 2T LC	50cc 2T AC	50cc 2T AC
Motore Kymco	Motore Kymco	Motore Kymco	Motore Kymco

IT	EN	FR				
ALBERO MESSA IN MOTO	KICK SHAFT	ARBRE DE DEMARREUR				
ALBERO MOTORE Con Cuscinetti e Paraoli	CRANKSHAFT with bearings and oil seals	VILEBREQUIN doté de Paliers et Joints d'huile				
ALBERO MOTORE Senza Cuscinetti e Paraoli	CRANKSHAFT without bearings and oil seals	VILEBREQUIN sans Paliers et Joints d'huile				
BIELLA	CONROD	BIELLE				
CAMPANA FRIZIONE	CLUTCH HOUSING	CLOCHE EMBRAYAGE				
CENTRALINA AD ANTICIPO FISSO	DIGITAL IGNITION UNIT	ALLUMAGE Fixe				
CENTRALINA AD ANTICIPO VARIABILE 4T	IGNITION UNIT Variable	ALLUMAGE Numérique				
CINGHIA DI TRASMISSIONE TOP	TRANSMISSION BELT TOP PERFORMANCES	COURROIE DE TRANSMISSION TOP PERFORMANCES		9931590	9931590	9931590
CINGHIA DI TRASMISSIONE Mitsubishi	TRANSMISSION BELT Mitsubishi	COURROIE DE TRANSMISSION Mitsubishi				
COLLETTORE ASPIRAZIONE	INLET MANIFOLD	COLLECTEUR ASPIRATION				
FRIZIONE CENTRIFUGA Interno Ø 105	CENTRIFUGAL CLUTCH Ø 105	EMBAYAGE CENTRIFUGE Ø 105				
FRIZIONE CENTRIFUGA Interno Ø 107	CENTRIFUGAL CLUTCH Ø 107	EMBAYAGE CENTRIFUGE Ø 107				
GANASCE FRENO	BRAKE SHOES	MÂCHOIRES FREIN				
GRUPPO TERMICO Ø Standard c/testa	CYLINDER KIT Ø standard with head	CYLINDRE COMPLET Ø Standard avec culasse				
GRUPPO TERMICO Ø Standard s/testa	CYLINDER KIT Ø standard without head	CYLINDRE COMPLET Ø Standard sans culasse				
GRUPPO TERMICO Ø Magg. c/testa	CYLINDER KIT BIG BORE with head	CYLINDRE COMPLET Ø Majoré avec culasse				
GRUPPO TERMICO Ø Magg. s/testa	CYLINDER KIT BIG BORE without head	CYLINDRE COMPLET Ø Majoré sans culasse				
GRUPPO TERMICO Modifica da AC a LC	CYLINDER KIT Conversion AC to LC	CYLINDRE COMPLET Modification de AC à LC				
KIT CUSCINETTI DA BANCO	BEARINGS KIT	KIT PALIERS DE VILEBREQUIN		KK01013	KK01013	KK01013
KIT REVISIONE POMPA ACQUA	WATER PUMP REPAIR KIT	KIT RÉVISION POMPE À EAU				
MEMBRANA CARBURATORE	CARBURETOR DIAPHRAGM	MEMBRANE CARBURATEUR				
MOTORINO D'AVVIAMENTO	STARTER ENGINE	DÉMARREUR ÉLECTRIQUE		MA00014	MA00014	MA00014
PULEGGIA FISSA	VARIATOR SHEAVE FIXED	POULIE FIXE				
RAPPORTI ALLUNGATI Primari	GÉARS KIT Primary	RAPPORTS ALLONGÉS Primaires				
RAPPORTI ALLUNGATI Secondari	GÉARS KIT Secondary	RAPPORTS ALLONGÉS Secondaires				
REGOLATORE DI TENSIONE	RECTIFIER	RÉGULATEUR DE TENSION		RE00013	RE00013	RE00013
RUOTA LIBERA	STARTER CLUTCH	ROUE LIBRE		RL00040	RL00040	RL00040
STATORE	STATOR	STATOR				
VALVOLE LAMELLARI	REED VALVE	CLAPET À LAMELLES				

KYMC0	KYMC0	KYMC0	MACAL	MACAL	MALAGUTI	MALAGUTI	MALAGUTI	MALAGUTI	MALAGUTI	MALAGUTI	MALAGUTI
VITALITY 4T	YUP	YUP EU2	STING	THUNDER	CENTRO EURO 2	CENTRO SL	CENTRO SL 4T	CIAK	CIAK EURO 2,3	CIAK EURO2	CIAK MASTER 4T
04-04	02-02	03-03	95-96	95-96	08-08	94-98	10-10	99-01	03-03	01-03	05-06
50cc 4T AC	50cc 2T AC	50cc 2T AC	50cc 2T AC	50cc 2T AC	50cc 4T AC	50cc 2T AC	50cc 4T AC	50cc 2T AC	50cc 2T AC	50cc 2T AC	50cc 4T AC
Motore Kymco	Motore Kymco	Motore Kymco	CY	MY	Motore Piaggio	MY	Motore Piaggio	MY	MY	MY	Motore Piaggio
				CI07487	CI07494	CI07487	CI07494	CI07487	CI07487	CI07487	CI07494
				IM07059		IM07059		IM07059	IM07059	IM07059	
				IM07014		IM07014		IM07014	IM07014	IM07014	
				IM07032		IM07032		IM07032	IM07032	IM07032	
				9924940		9924940		9924940	9924940	9924940	
9931590	9931590	9931590		9907770		9907770		9907770	9907770	9907770	
				9935270		9935270		9935270	9935270	9935270	
CT00743				CT00725		CT00725		CT00725	CT00725	CT00725	
				9911060		9911060		9911060	9911060	9911060	
				9910020 9925130		9910020 9925130		9910020 9925130	9910020 9925130	9910020 9925130	
				9931140		9931140		9931140	9931140	9931140	
				KT00095		KT00095		KT00095	KT00095	KT00095	
				9931340 KT00087		9931340 KT00087		9931340 KT00087	9931340 KT00087	9931340 KT00087	
9925140 KT00132					9925150 KT00133		9925150 KT00133				9925150 KT00133
				9911090		9911090		9911090	9911090	9911090	
	KK01013	KK01013		KK01000 KK01002		KK01000 KK01002		KK01000 KK01002	KK01000 KK01002	KK01000 KK01002	
	MA00014	MA00014	MA00001	MA00001	MA00015	MA00001	MA00015	MA00001	MA00001	MA00001	MA00015
			PL04055 PL04056	PL04055 PL04056		PL04055 PL04056		PL04055 PL04056	PL04055 PL04056	PL04055 PL04056	
				9913300		9913300		9913300	9913300	9913300	
RE00013	RE00013	RE00013			RE00018	RE00014	RE00018	RE00014		RE00014	
RL00040	RL00040	RL00040		AA00767 RL00001	RL00039	AA00767 RL00001	RL00039	AA00767 RL00001	AA00767 RL00001	AA00767 RL00001	RL00039
ST00028			SD00002	SD00002		SD00002		SD00002		SD00002	
				9908370		9908370		9908370	9908370	9908370	

SCOOTER 50cc

TOP
- performances -



MALAGUTI	MALAGUTI	MALAGUTI	MALAGUTI
CIAK MASTER EURO 2	CIAK MASTER EURO 2	CROSSER CR1	DVD
05-06	06-06	95-98	10-10
50cc 4T AC	50cc 2T AC	50cc 2T AC	50cc 4T AC
Motore Piaggio	MY	Motore Morini	Tipo Kymco

IT	EN	FR				
ALBERO MESSA IN MOTO	KICK SHAFT	ARBRE DE DEMARREUR			CI07487	
ALBERO MOTORE Con Cuscinetti e Paraoli	CRANKSHAFT with bearings and oil seals	VILEBREQUIN doté de Paliers et Joints d'huile			IM07059	
ALBERO MOTORE Senza Cuscinetti e Paraoli	CRANKSHAFT without bearings and oil seals	VILEBREQUIN sans Paliers et Joints d'huile		IM07014		
BIELLA	CONROD	BIELLE			IM07032	
CAMPANA FRIZIONE	CLUTCH HOUSING	CLOCHE EMBRAYAGE			9924940	
CENTRALINA AD ANTICIPO FISSO	DIGITAL IGNITION UNIT	ALLUMAGE Fixe				
CENTRALINA AD ANTICIPO VARIABILE 4T	IGNITION UNIT Variable	ALLUMAGE Numérique				
CINGHIA DI TRASMISSIONE TOP	TRANSMISSION BELT TOP PERFORMANCES	COURROIE DE TRANSMISSION TOP PERFORMANCES			9907770	
CINGHIA DI TRASMISSIONE Mitsubishi	TRANSMISSION BELT Mitsubishi	COURROIE DE TRANSMISSION Mitsubishi			9935270	
COLLETTORE ASPIRAZIONE	INLET MANIFOLD	COLLECTEUR ASPIRATION			CT00725	
FRIZIONE CENTRIFUGA Interno Ø 105	CENTRIFUGAL CLUTCH Ø 105	EMBAYAGE CENTRIFUGE Ø 105				
FRIZIONE CENTRIFUGA Interno Ø 107	CENTRIFUGAL CLUTCH Ø 107	EMBAYAGE CENTRIFUGE Ø 107			9925130	
GANASCE FRENO	BRAKE SHOES	MÂCHOIRES FREIN				
GRUPPO TERMICO Ø Standard c/testa	CYLINDER KIT Ø standard with head	CYLINDRE COMPLET Ø Standard avec culasse			9931140	
GRUPPO TERMICO Ø Standard s/testa	CYLINDER KIT Ø standard without head	CYLINDRE COMPLET Ø Standard sans culasse			KT00095	
GRUPPO TERMICO Ø Magg. c/testa	CYLINDER KIT BIG BORE with head	CYLINDRE COMPLET Ø Majoré avec culasse			9931340 KT00087	
GRUPPO TERMICO Ø Magg. s/testa	CYLINDER KIT BIG BORE without head	CYLINDRE COMPLET Ø Majoré sans culasse			9925150 KT00133	KT00057
GRUPPO TERMICO Modifica da AC a LC	CYLINDER KIT Conversion AC to LC	CYLINDRE COMPLET Modification de AC à LC			9911090	
KIT CUSCINETTI DA BANCO	BEARINGS KIT	KIT PALIERS DE VILEBREQUIN			KK01000 KK01002	
KIT REVISIONE POMPA ACQUA	WATER PUMP REPAIR KIT	KIT RÉVISION POMPE À EAU				
MEMBRANA CARBURATORE	CARBURETOR DIAPHRAGM	MEMBRANE CARBURATEUR				
MOTORINO D'AVVIAMENTO	STARTER ENGINE	DÉMARREUR ÉLECTRIQUE			MA00001	
PULEGGIA FISSA	VARIATOR SHEAVE FIXED	POULIE FIXE			PL04055 PL04056	
RAPPORTI ALLUNGATI Primari	GÉARS KIT Primary	RAPPORTS ALLONGÉS Primaires			9913300	
RAPPORTI ALLUNGATI Secondari	GÉARS KIT Secondary	RAPPORTS ALLONGÉS Secondaires				
REGOLATORE DI TENSIONE	RECTIFIER	RÉGULATEUR DE TENSION			RE00018	RE00014
RUOTA LIBERA	STARTER CLUTCH	ROUE LIBRE			AA00767 RL00001	
STATORE	STATOR	STATOR				
VALVOLE LAMELLARI	REED VALVE	CLAPET À LAMELLES			9908370	

MALAGUTI	MALAGUTI	MALAGUTI	MALAGUTI	MALAGUTI	MALAGUTI	MALAGUTI	MALAGUTI	MALAGUTI	MALAGUTI	MALAGUTI	MALAGUTI
F10	F10 AC ECO	F10 AC WAP	F10 EURO 2	F10 EURO 2 2,3	F10 RESTYLING EURO 2	F12 PHANTOM	F12 PHANTOM EURO 2	F12 PHANTOM EURO 2 2,3	F12 PHANTOM LC	F12 PHANTOM LC EURO 2 2,3	F12 R PHANTOM AC
92-00	09-10	08-08	02-06	03-04	06-06	94-98	02-02	03-04	94-98	03-04	07-08
50cc 2T AC	50cc 2T AC	50cc 2T AC	50cc 2T AC	50cc 2T AC	50cc 2T AC	50cc 2T AC	50cc 2T LC	50cc 2T AC	50cc 2T LC	50cc 2T LC	50cc 2T AC
CY	Tipo Keeway	Tipo Keeway	CY	CY	CY	MY	MA vent.	MY	MA	MA vent.	Tipo Keeway
						CI07487	CI07487	CI07487	CI07487	CI07487	
IM07059			IM07059	IM07059	IM07059	IM07059			IM07059		
IM07014			IM07014	IM07014	IM07014	IM07014	IM07018	IM07018	IM07014	IM07018	
IM07032			IM07032	IM07032	IM07032	IM07032	IM07032	IM07032	IM07032	IM07032	
9924940			9924940	9924940	9924940	9924940		9924940	9924940		
9907900		9913280	9907900	9907900	9907900	9907770	9907770	9907770	9907770	9907770	9913280
9935340		9935800	9935340	9935340	9935340	9935270	9935270	9935270	9935270	9935270	9935800
CT00725			CT00725	CT00725	CT00725	CT00725	CT00725	CT00725	CT00725	CT00725	
9911060			9911060	9911060		9911060		9911060	9911060	9911060	
9910020 9925130		9925130	9910020 9925130	9910020 9925130	9925130	9910020 9925130	9910020 9925130	9910020 9925130	9910020 9925130	9910020 9925130	9925130
9931140	9934200	9925650	9931140	9931140	9931140	9931140	9931110	9931140	9931110	9931110	9925650
KT00095		KT00129	KT00095	KT00095	KT00095	KT00095	KT00094	KT00095	KT00094	KT00094	KT00129
9931340 KT00087	9934300	9924890 KT00128	9931340 KT00087	9931340 KT00087	9931340 KT00087	9931340 KT00087	9931310	9931340 KT00087	9931310 KT00109	9931310	9924890 KT00128
9911090			9911090	9911090	9911090	9911090		9911090			
KK01000 KK01002			KK01000 KK01002	KK01000 KK01002	KK01000 KK01002	KK01000 KK01002	KK01000 KK01002	KK01000 KK01002	KK01000 KK01002	KK01000 KK01002	KK01000 KK01002
							AA00788		AA00788	AA00788	
MA00001			MA00001	MA00001	MA00001	MA00001	MA00001	MA00001	MA00001	MA00001	MA00001
PL04055 PL04056			PL04055 PL04056	PL04055 PL04056	PL04055 PL04056	PL04055 PL04056	PL04055 PL04056	PL04055 PL04056	PL04055 PL04056	PL04055 PL04056	PL04055 PL04056
						9913300		9913300	9913300		
						9909520		9909520	9909520		
RE00014		RE00014	RE00014				RE00014		RE00014		RE00014
AA00767 RL00001			AA00767 RL00001	AA00767 RL00001	AA00767 RL00001	AA00767 RL00001	AA00767 RL00001	AA00767 RL00001	AA00767 RL00001	AA00767 RL00001	AA00767 RL00001
SD00002			SD00002			SD00002			SD00002		
9908370			9908370	9908370	9908370	9908370	9908370	9908370	9908370	9908370	

SCOOTER 50cc

TOP
- performances -



MALAGUTI	MALAGUTI	MALAGUTI	MALAGUTI
F12 R PHANTOM AC	F12 R PHANTOM LC	F12 RESTYLING EURO 1	F12 RESTYLING EURO 2
09-10	07-10	99-02	06-06
50cc 2T AC	50cc 2T LC	50cc 2T LC	50cc 2T AC
Tipo Keeway	MA	MA vent.	MY

IT	EN	FR	
ALBERO MESSA IN MOTO	KICK SHAFT	ARBRE DE DEMARREUR	
ALBERO MOTORE Con Cuscinetti e Paraoli	CRANKSHAFT with bearings and oil seals	VILEBREQUIN doté de Paliers et Joints d'huile	
ALBERO MOTORE Senza Cuscinetti e Paraoli	CRANKSHAFT without bearings and oil seals	VILEBREQUIN sans Paliers et Joints d'huile	
BIELLA	CONROD	BIELLE	
CAMPANA FRIZIONE	CLUTCH HOUSING	CLOCHE EMBRAYAGE	
CENTRALINA AD ANTICIPO FISSO	DIGITAL IGNITION UNIT	ALLUMAGE Fixe	
CENTRALINA AD ANTICIPO VARIABILE 4T	IGNITION UNIT Variable	ALLUMAGE Numérique	
CINGHIA DI TRASMISSIONE TOP	TRANSMISSION BELT TOP PERFORMANCES	COURROIE DE TRANSMISSION TOP PERFORMANCES	
CINGHIA DI TRASMISSIONE Mitsubishi	TRANSMISSION BELT Mitsubishi	COURROIE DE TRANSMISSION Mitsubishi	
COLLETTORE ASPIRAZIONE	INLET MANIFOLD	COLLECTEUR ASPIRATION	
FRIZIONE CENTRIFUGA Interno Ø 105	CENTRIFUGAL CLUTCH Ø 105	EMBAYAGE CENTRIFUGE Ø 105	
FRIZIONE CENTRIFUGA Interno Ø 107	CENTRIFUGAL CLUTCH Ø 107	EMBAYAGE CENTRIFUGE Ø 107	
GANASCE FRENO	BRAKE SHOES	MÂCHOIRES FREIN	
GRUPPO TERMICO Ø Standard c/testa	CYLINDER KIT Ø standard with head	CYLINDRE COMPLET Ø Standard avec culasse	
GRUPPO TERMICO Ø Standard s/testa	CYLINDER KIT Ø standard without head	CYLINDRE COMPLET Ø Standard sans culasse	
GRUPPO TERMICO Ø Magg. c/testa	CYLINDER KIT BIG BORE with head	CYLINDRE COMPLET Ø Majoré avec culasse	
GRUPPO TERMICO Ø Magg. s/testa	CYLINDER KIT BIG BORE without head	CYLINDRE COMPLET Ø Majoré sans culasse	
GRUPPO TERMICO Modifica da AC a LC	CYLINDER KIT Conversion AC to LC	CYLINDRE COMPLET Modification de AC à LC	
KIT CUSCINETTI DA BANCO	BEARINGS KIT	KIT PALIERS DE VILEBREQUIN	
KIT REVISIONE POMPA ACQUA	WATER PUMP REPAIR KIT	KIT RÉVISION POMPE À EAU	
MEMBRANA CARBURATORE	CARBURETOR DIAPHRAGM	MEMBRANE CARBURATEUR	
MOTORINO D'AVVIAMENTO	STARTER ENGINE	DÉMARREUR ÉLECTRIQUE	
PULEGGIA FISSA	VARIATOR SHEAVE FIXED	POULIE FIXE	
RAPPORTI ALLUNGATI Primari	GÉARS KIT Primary	RAPPORTS ALLONGÉS Primaires	
RAPPORTI ALLUNGATI Secondari	GÉARS KIT Secondary	RAPPORTS ALLONGÉS Secondaires	
REGOLATORE DI TENSIONE	RECTIFIER	RÉGULATEUR DE TENSION	
RUOTA LIBERA	STARTER CLUTCH	ROUE LIBRE	
STATORE	STATOR	STATOR	
VALVOLE LAMELLARI	REED VALVE	CLAPET À LAMELLES	

MALAGUTI	MALAGUTI	MALAGUTI	MALAGUTI	MALAGUTI	MALAGUTI	MALAGUTI	MBK	MBK	MBK	MBK	MBK
F12 RESTYLING LC EURO 2	F15 FIRE FOX	F15 FIRE FOX AIR COOLED	F15 FIRE FOX EURO 2	F15 FIRE FOX EURO 2	F15 FIRE FOX EURO 2,3	YESTERDAY	BOOSTER	BOOSTER	BOOSTER	BOOSTER EURO 2	BOOSTER NG
06-06	96-98	05-06	02-03	04-06	03-04	97-00	90-91	90-04	92-94	04-04	95-03
50cc 2T LC	50cc 2T LC	50cc 2T AC	50cc 2T LC	50cc 2T LC	50cc 2T LC	50cc 2T AC	50cc 2T AC	50cc 2T AC	50cc 2T AC	50cc 2T AC	50cc 2T AC
MA vent.	MA	MY	MA	MA	MA	CY	CW	CW	CW	CW	CW
CI07487	CI07487	CI07487	CI07487	CI07487	CI07487		CI07487	CI07487	CI07487	CI07487	CI07487
	IM07059	IM07059	IM07059	IM07059	IM07059	IM07059	IM07058	IM07058	IM07058	IM07058	IM07058
IM07018	IM07014	IM07014	IM07014	IM07014	IM07014	IM07014	IM07013	IM07013	IM07013	IM07013	IM07013
IM07032	IM07032	IM07032	IM07032	IM07032	IM07032	IM07032	IM07032	IM07032	IM07032	IM07032	IM07032
	9924940	9924940	9924940	9924940	9924940	9924940					
							9910100	9910100	9910100		9910100
9907770	9907770	9907770	9907770	9907770	9907770	9907900	9907770	9907770	9907770	9907770	9907770
9935270	9935270	9935270	9935270	9935270	9935270	9935340	9935270	9935270	9935270	9935270	9935270
CT00725	CT00725	CT00725	CT00725	CT00725	CT00725	CT00725	CT00726	CT00726	CT00726	CT00726	CT00726
	9911060		9911060		9911060	9911060	9911060	9911060	9911060	9911060	9911060
9925130	9910020 9925130	9925130	9910020 9925130	9925130	9910020 9925130	9910020 9925130	9910020 9925130	9910020 9925130	9910020 9925130	9910020 9925130	9910020 9925130
9931110	9931110	9931140	9931110	9931110	9931110	9931140	9931170	9931170	9931170	9931170	9931170
KT00094	KT00094	KT00095	KT00094	KT00094	KT00094	KT00095	KT00096	KT00096	KT00096	KT00096	KT00096
9931310	9931310 KT00109	9931340 KT00087	9931310 KT00109	9931310 KT00109	9931310 KT00109	9931340 KT00087	9931370 KT00088	9931370 KT00088	9931370 KT00088	9931370 KT00088	9931370 KT00088
		9911090				9911090					
KK01000 KK01002	KK01000 KK01002	KK01000 KK01002	KK01000 KK01002	KK01000 KK01002	KK01000 KK01002	KK01000 KK01002	KK01000 KK01002	KK01000 KK01002	KK01000 KK01002	KK01000 KK01002	KK01000 KK01002
AA00788	AA00788		AA00788	AA00788	AA00788						
MA00001	MA00001	MA00001	MA00001	MA00001	MA00001	MA00001	MA00001	MA00001	MA00001	MA00001	MA00001
PL04055 PL04056	PL04055 PL04056	PL04055 PL04056	PL04055 PL04056	PL04055 PL04056	PL04055 PL04056	PL04055 PL04056				PL04055 PL04056	
	9913300	9913300	9913300	9913300	9913300		9913300	9913300	9913300	9913300	9913300
	9909520	9909520	9909520	9909520	9909520						9909520
	RE00014	RE00014	RE00014	RE00014		RE00014	RE00014	RE00014	RE00014	RE00015	RE00014
AA00767 RL00001	AA00767 RL00001	AA00767 RL00001	AA00767 RL00001	AA00767 RL00001	AA00767 RL00001	AA00767 RL00001	AA00767 RL00001	AA00767 RL00001	AA00767 RL00001	AA00767 RL00001	AA00767 RL00001
	SD00002					SD00002					
9908370	9908370	9908370	9908370	9908370	9908370	9908370	9906520	9906520	9906520	9906520	9906520

SCOOTER 50cc

SCOOTER 50cc

TOP
- performances -



MBK	MBK	MBK	MBK
BOOSTER NG	BOOSTER ROCKET	BOOSTER ROCKET	BOOSTER ROCKET
03-03	97-98	97-98	97-98
50cc 2T AC	50cc 2T AC	50cc 2T AC	50cc 2T AC
CW	CW	CW	CW

IT	EN	FR				
ALBERO MESSA IN MOTO	KICK SHAFT	ARBRE DE DEMARREUR		CI07487	CI07487	
ALBERO MOTORE Con Cuscinetti e Paraoli	CRANKSHAFT with bearings and oil seals	VILEBREQUIN doté de Paliers et Joints d'huile		IM07058	IM07058	
ALBERO MOTORE Senza Cuscinetti e Paraoli	CRANKSHAFT without bearings and oil seals	VILEBREQUIN sans Paliers et Joints d'huile		IM07013	IM07013	
BIELLA	CONROD	BIELLE		IM07032	IM07032	
CAMPANA FRIZIONE	CLUTCH HOUSING	CLOCHE EMBRAYAGE				
CENTRALINA AD ANTICIPO FISSO	DIGITAL IGNITION UNIT	ALLUMAGE Fixe			9910100	
CENTRALINA AD ANTICIPO VARIABILE 4T	IGNITION UNIT Variable	ALLUMAGE Numérique				
CINGHIA DI TRASMISSIONE TOP	TRANSMISSION BELT TOP PERFORMANCES	COURROIE DE TRANSMISSION TOP PERFORMANCES		9907770	9907770	
CINGHIA DI TRASMISSIONE Mitsubishi	TRANSMISSION BELT Mitsubishi	COURROIE DE TRANSMISSION Mitsubishi		9935270	9935270	
COLLETTORE ASPIRAZIONE	INLET MANIFOLD	COLLECTEUR ASPIRATION		CT00726	CT00726	
FRIZIONE CENTRIFUGA Interno Ø 105	CENTRIFUGAL CLUTCH Ø 105	EMBAYAGE CENTRIFUGE Ø 105		9911060	9911060	
FRIZIONE CENTRIFUGA Interno Ø 107	CENTRIFUGAL CLUTCH Ø 107	EMBAYAGE CENTRIFUGE Ø 107		9910020 9925130	9910020 9925130	
GANASCE FRENO	BRAKE SHOES	MÂCHOIRES FREIN				
GRUPPO TERMICO Ø Standard c/testa	CYLINDER KIT Ø standard with head	CYLINDRE COMPLET Ø Standard avec culasse		9931170	9931170	
GRUPPO TERMICO Ø Standard s/testa	CYLINDER KIT Ø standard without head	CYLINDRE COMPLET Ø Standard sans culasse		KT00096	KT00096	
GRUPPO TERMICO Ø Magg. c/testa	CYLINDER KIT BIG BORE with head	CYLINDRE COMPLET Ø Majoré avec culasse		9931370 KT00088	9931370 KT00088	
GRUPPO TERMICO Ø Magg. s/testa	CYLINDER KIT BIG BORE without head	CYLINDRE COMPLET Ø Majoré sans culasse				
GRUPPO TERMICO Modifica da AC a LC	CYLINDER KIT Conversion AC to LC	CYLINDRE COMPLET Modification de AC à LC				
KIT CUSCINETTI DA BANCO	BEARINGS KIT	KIT PALIERS DE VILEBREQUIN		KK01000 KK01002	KK01000 KK01002	
KIT REVISIONE POMPA ACQUA	WATER PUMP REPAIR KIT	KIT RÉVISION POMPE À EAU				
MEMBRANA CARBURATORE	CARBURETOR DIAPHRAGM	MEMBRANE CARBURATEUR				
MOTORINO D'AVVIAMENTO	STARTER ENGINE	DÉMARREUR ÉLECTRIQUE		MA00001	MA00001	
PULEGGIA FISSA	VARIATOR SHEAVE FIXED	POULIE FIXE		PL04055 PL04056	PL04055 PL04056	PL04055 PL04056
RAPPORTI ALLUNGATI Primari	GÉARS KIT Primary	RAPPORTS ALLONGÉS Primaires		9913300	9913300	
RAPPORTI ALLUNGATI Secondari	GÉARS KIT Secondary	RAPPORTS ALLONGÉS Secondaires		9909520		
REGOLATORE DI TENSIONE	RECTIFIER	RÉGULATEUR DE TENSION		RE00015	RE00014	
RUOTA LIBERA	STARTER CLUTCH	ROUE LIBRE		AA00767 RL00001	AA00767 RL00001	
STATORE	STATOR	STATOR				
VALVOLE LAMELLARI	REED VALVE	CLAPET À LAMELLES		9906520	9906520	

MBK	MBK	MBK	MBK	MBK	MBK	MBK	MBK	MBK	MBK	MBK	MBK
BOOSTER SPIRIT	BOOSTER SPIRIT	BOOSTER SPIRIT	BOOSTER SPIRIT	BOOSTER SPIRIT EURO2	BOOSTER TRACK	BOOSTER X IE	EVOLIS	FIZZ	FLIPPER	FLIPPER EURO 2	FORTE
96-98	99-00	00-00	03-03	03-03	96-98	08-08	92-95	94-95	98-04	03-03	94-96
50cc 2T AC	50cc 2T AC	50cc 2T AC	50cc 2T AC	50cc 2T AC	50cc 2T AC	50cc 4T-3V LC	50cc 2T AC	50cc 2T AC	50cc 2T AC	50cc 2T AC	50cc 2T AC
CW	CW	CW	CW	CW	CW	15P1	CY	CY	MY	MY	CY
CI07487	CI07487	CI07487	CI07487	CI07487	CI07487				CI07487	CI07487	
IM07058	IM07058	IM07058	IM07058	IM07058	IM07058		IM07059	IM07059	IM07059	IM07059	IM07059
IM07013	IM07013	IM07013	IM07013	IM07013	IM07013		IM07014	IM07014	IM07014	IM07014	IM07014
IM07032	IM07032	IM07032	IM07032	IM07032	IM07032		IM07032	IM07032	IM07032	IM07032	IM07032
							9924940	9924940	9924940	9924940	9924940
9910100	9910100	9910100			9910100		9910100	9910100	9910100		
9907770	9907770	9907770	9907770	9907770	9907770		9907900	9907900	9907770	9907770	9907900
9935270	9935270	9935270	9935270	9935270	9935270		9935340	9935340	9935270	9935270	9935340
CT00726	CT00726	CT00726	CT00726	CT00726	CT00726		CT00725	CT00725	CT00725	CT00725	CT00725
9911060	9911060	9911060	9911060	9911060	9911060				9911060	9911060	
9910020 9925130	9910020 9925130	9910020 9925130	9910020 9925130	9910020 9925130	9910020 9925130	9925130	9925130	9925130	9910020 9925130	9910020 9925130	9925130
9931170	9931170	9931170	9931170	9931170	9931170		9931140	9931140	9931140	9931140	9931140
KT00096	KT00096	KT00096	KT00096	KT00096	KT00096		KT00095	KT00095	KT00095	KT00095	KT00095
9931370 KT00088	9931370 KT00088	9931370 KT00088	9931370 KT00088	9931370 KT00088	9931370 KT00088		9931340 KT00087	9931340 KT00087	9931340 KT00087	9931340 KT00087	9931340 KT00087
						9926330					
							9911090	9911090	9911090	9911090	9911090
KK01000 KK01002	KK01000 KK01002	KK01000 KK01002	KK01000 KK01002	KK01000 KK01002	KK01000 KK01002		KK01000 KK01002	KK01000 KK01002	KK01000 KK01002	KK01000 KK01002	KK01000 KK01002
MA00001	MA00001	MA00001	MA00001	MA00001	MA00001		MA00001	MA00001	MA00001	MA00001	MA00001
	PL04055 PL04056		PL04055 PL04056				PL04055 PL04056	PL04055 PL04056	PL04055 PL04056	PL04055 PL04056	PL04055 PL04056
9913300	9913300	9913300	9913300	9913300	9913300				9913300	9913300	
RE00014	RE00014	RE00014	RE00015	RE00015	RE00014		RE00014	RE00014	RE00014	RE00015	RE00014
AA00767 RL00001	AA00767 RL00001	AA00767 RL00001	AA00767 RL00001	AA00767 RL00001	AA00767 RL00001		AA00767 RL00001	AA00767 RL00001	AA00767 RL00001	AA00767 RL00001	AA00767 RL00001
9906520	9906520	9906520	9906520	9906520	9906520		9908370	9908370	9908370	9908370	9908370

SCOOTER 50cc

SCOOTER 50cc

TOP
- performances -



MBK	MBK	MBK	MBK
MACH G	MACH G LC	NITRO	NITRO EURO 2
02-04	02-04	97-04	03-03
50cc 2T AC	50cc 2T LC	50cc 2T LC	50cc 2T LC
MY	MA	MA	MA

IT	EN	FR				
ALBERO MESSA IN MOTO	KICK SHAFT	ARBRE DE DEMARREUR		C107487	C107487	C107487
ALBERO MOTORE Con Cuscinetti e Paraoli	CRANKSHAFT with bearings and oil seals	VILEBREQUIN doté de Paliers et Joints d'huile		IM07059	IM07059	IM07059
ALBERO MOTORE Senza Cuscinetti e Paraoli	CRANKSHAFT without bearings and oil seals	VILEBREQUIN sans Paliers et Joints d'huile		IM07014	IM07014	IM07014
BIELLA	CONROD	BIELLE		IM07032	IM07032	IM07032
CAMPANA FRIZIONE	CLUTCH HOUSING	CLOCHE EMBRAYAGE		9924940	9924940	9924940
CENTRALINA AD ANTICIPO FISSO	DIGITAL IGNITION UNIT	ALLUMAGE Fixe				9910100
CENTRALINA AD ANTICIPO VARIABILE 4T	IGNITION UNIT Variable	ALLUMAGE Numérique				
CINGHIA DI TRASMISSIONE TOP	TRANSMISSION BELT TOP PERFORMANCES	COURROIE DE TRANSMISSION TOP PERFORMANCES		9907770	9907770	9907770
CINGHIA DI TRASMISSIONE Mitsubishi	TRANSMISSION BELT Mitsubishi	COURROIE DE TRANSMISSION Mitsubishi		9935270	9935270	9935270
COLLETTORE ASPIRAZIONE	INLET MANIFOLD	COLLECTEUR ASPIRATION		CT00725	CT00725	CT00725
FRIZIONE CENTRIFUGA Interno Ø 105	CENTRIFUGAL CLUTCH Ø 105	EMBAYAGE CENTRIFUGE Ø 105		9911060	9911060	9911060
FRIZIONE CENTRIFUGA Interno Ø 107	CENTRIFUGAL CLUTCH Ø 107	EMBAYAGE CENTRIFUGE Ø 107		9910020 9925130	9910020 9925130	9910020 9925130
GANASCE FRENO	BRAKE SHOES	MÂCHOIRES FREIN				
GRUPPO TERMICO Ø Standard c/testa	CYLINDER KIT Ø standard with head	CYLINDRE COMPLET Ø Standard avec culasse		9931140	9931110	9931110
GRUPPO TERMICO Ø Standard s/testa	CYLINDER KIT Ø standard without head	CYLINDRE COMPLET Ø Standard sans culasse		KT00095	KT00094	KT00094
GRUPPO TERMICO Ø Magg. c/testa	CYLINDER KIT BIG BORE with head	CYLINDRE COMPLET Ø Majoré avec culasse		9931340 KT00087	9931310 KT00109	9931310 KT00109
GRUPPO TERMICO Ø Magg. s/testa	CYLINDER KIT BIG BORE without head	CYLINDRE COMPLET Ø Majoré sans culasse				
GRUPPO TERMICO Modifica da AC a LC	CYLINDER KIT Conversion AC to LC	CYLINDRE COMPLET Modification de AC à LC		9911090		
KIT CUSCINETTI DA BANCO	BEARINGS KIT	KIT PALIERS DE VILEBREQUIN		KK01000 KK01002	KK01000 KK01002	KK01000 KK01002
KIT REVISIONE POMPA ACQUA	WATER PUMP REPAIR KIT	KIT RÉVISION POMPE À EAU			AA00788	AA00788
MEMBRANA CARBURATORE	CARBURETOR DIAPHRAGM	MEMBRANE CARBURATEUR				
MOTORINO D'AVVIAMENTO	STARTER ENGINE	DÉMARREUR ÉLECTRIQUE		MA00001	MA00001	MA00001
PULEGGIA FISSA	VARIATOR SHEAVE FIXED	POULIE FIXE		PL04055 PL04056	PL04055 PL04056	PL04055 PL04056
RAPPORTI ALLUNGATI Primari	GÉARS KIT Primary	RAPPORTS ALLONGÉS Primaires		9913300	9913300	9913300
RAPPORTI ALLUNGATI Secondari	GÉARS KIT Secondary	RAPPORTS ALLONGÉS Secondaires		9909520	9909520	9909520
REGOLATORE DI TENSIONE	RECTIFIER	RÉGULATEUR DE TENSION		RE00015	RE00015	RE00014
RUOTA LIBERA	STARTER CLUTCH	ROUE LIBRE		AA00767 RL00001	AA00767 RL00001	AA00767 RL00001
STATORE	STATOR	STATOR				
VALVOLE LAMELLARI	REED VALVE	CLAPET À LAMELLES		9908370	9908370	9908370

MBK	MBK	MBK	MBK	MBK	MBK	MOTRON	MOTRON	MOTRON	PEUGEOT	PEUGEOT	PEUGEOT
OVETTO	OVETTO 4T	OVETTO EURO 2	SORRISO	STUNT	TARGET	STING	SYNCRO	THUNDER	BUXY	BUXY RS	E-VIVACITY (EC-45 KM/H)
97-04	09-11	02-02	95-96	00-02	91-95	95-96	98-00	95-98	90-02	90-02	16-16
50cc 2T AC	50cc 4T-3V LC	50cc 2T AC	50cc 2T AC	50cc 2T AC	50cc 2T AC	50cc 2T AC	50cc 2T AC	50cc 2T AC	50cc 2T AC	50cc 2T AC	50cc
MY	5C3	MY	Tipo CW	CW	Tipo CW	CY	MY	MY	Motore Peugeot	Motore Peugeot	
CI07487		CI07487		CI07487			CI07487	CI07487			
IM07059		IM07059		IM07058			IM07059	IM07059	IM07061	IM07061	
IM07014		IM07014		IM07013			IM07014	IM07014	IM07016	IM07016	
IM07032		IM07032		IM07032			IM07032	IM07032			
9924940		9924940					9924940	9924940			
9910100				9910100							
9907770		9907770		9907770			9907770	9907770	9910790	9910790	
9935270		9935270		9935270			9935270	9935270	9935240 9935570	9935240 9935570	9935420
CT00725		CT00725		CT00726			CT00725	CT00725			
9911060		9911060	9911060	9911060	9911060		9911060	9911060			
9910020 9925130	9925130	9910020 9925130	9910020 9925130	9910020 9925130	9910020 9925130		9910020 9925130	9910020 9925130	9910020	9910020	
9931140		9931140		9931170			9931140	9931140	9924770	9924770	
KT00095		KT00095		KT00096			KT00095	KT00095	KT00123	KT00123	
9931340 KT00087		9931340 KT00087		9931370 KT00088			9931340 KT00087	9931340 KT00087	9908660	9908660	
	9926330								KT00058	KT00058	
9911090		9911090					9911090	9911090			
KK01000 KK01002		KK01000 KK01002		KK01000 KK01002			KK01000 KK01002	KK01000 KK01002	KK01005	KK01005	
MA00001		MA00001		MA00001		MA00001	MA00001	MA00001	MA00019		
PL04055 PL04056		PL04055 PL04056		PL04055 PL04056		PL04055 PL04056	PL04055 PL04056	PL04055 PL04056			
9913300		9913300		9913300 9909520			9913300	9913300			
RE00014		RE00015		RE00014							
AA00767 RL00001		AA00767 RL00001		AA00767 RL00001			AA00767 RL00001	AA00767 RL00001			
						SD00002	SD00002	SD00002			
9908370		9908370		9906520			9908370	9908370	9912550	9912550	

SCOOTER 50cc

TOP
- performances -



PEUGEOT PEUGEOT PEUGEOT PEUGEOT

ELYSEO JET C-TECH JET FORCE KISBEE

90-02 90-02 90-02 00-00

50cc 2T AC 50cc 2T LC 50cc 2T LC 50cc 2T AC

Motore Peugeot Motore Peugeot Motore Peugeot Motore Peugeot

IT	EN	FR				
ALBERO MESSA IN MOTO	KICK SHAFT	ARBRE DE DEMARREUR				
ALBERO MOTORE Con Cuscinetti e Paraoli	CRANKSHAFT with bearings and oil seals	VILEBREQUIN doté de Paliers et Joints d'huile		IM07061		
ALBERO MOTORE Senza Cuscinetti e Paraoli	CRANKSHAFT without bearings and oil seals	VILEBREQUIN sans Paliers et Joints d'huile		IM07016		
BIELLA	CONROD	BIELLE				
CAMPANA FRIZIONE	CLUTCH HOUSING	CLOCHE EMBRAYAGE				
CENTRALINA AD ANTICIPO FISSO	DIGITAL IGNITION UNIT	ALLUMAGE Fixe				
CENTRALINA AD ANTICIPO VARIABILE 4T	IGNITION UNIT Variable	ALLUMAGE Numérique				
CINGHIA DI TRASMISSIONE TOP	TRANSMISSION BELT TOP PERFORMANCES	COURROIE DE TRANSMISSION TOP PERFORMANCES		9910790		9910790
CINGHIA DI TRASMISSIONE Mitsubishi	TRANSMISSION BELT Mitsubishi	COURROIE DE TRANSMISSION Mitsubishi		9935240 9935570		9935240 9935570
COLLETTORE ASPIRAZIONE	INLET MANIFOLD	COLLECTEUR ASPIRATION			CT00741	CT00741
FRIZIONE CENTRIFUGA Interno Ø 105	CENTRIFUGAL CLUTCH Ø 105	EMBAYAGE CENTRIFUGE Ø 105				
FRIZIONE CENTRIFUGA Interno Ø 107	CENTRIFUGAL CLUTCH Ø 107	EMBAYAGE CENTRIFUGE Ø 107		9910020		9910020
GANASCE FRENO	BRAKE SHOES	MÂCHOIRES FREIN				
GRUPPO TERMICO Ø Standard c/testa	CYLINDER KIT Ø standard with head	CYLINDRE COMPLET Ø Standard avec culasse		9924770		
GRUPPO TERMICO Ø Standard s/testa	CYLINDER KIT Ø standard without head	CYLINDRE COMPLET Ø Standard sans culasse		KT00123		
GRUPPO TERMICO Ø Magg. c/testa	CYLINDER KIT BIG BORE with head	CYLINDRE COMPLET Ø Majoré avec culasse		9908660		
GRUPPO TERMICO Ø Magg. s/testa	CYLINDER KIT BIG BORE without head	CYLINDRE COMPLET Ø Majoré sans culasse		KT00058		
GRUPPO TERMICO Modifica da AC a LC	CYLINDER KIT Conversion AC to LC	CYLINDRE COMPLET Modification de AC à LC				
KIT CUSCINETTI DA BANCO	BEARINGS KIT	KIT PALIERS DE VILEBREQUIN				
KIT REVISIONE POMPA ACQUA	WATER PUMP REPAIR KIT	KIT RÉVISION POMPE À EAU				
MEMBRANA CARBURATORE	CARBURETOR DIAPHRAGM	MEMBRANE CARBURATEUR				
MOTORINO D'AVVIAMENTO	STARTER ENGINE	DÉMARREUR ÉLECTRIQUE		MA00019		MA00019
PULEGGIA FISSA	VARIATOR SHEAVE FIXED	POULIE FIXE				
RAPPORTI ALLUNGATI Primari	GÉARS KIT Primary	RAPPORTS ALLONGÉS Primaires				
RAPPORTI ALLUNGATI Secondari	GÉARS KIT Secondary	RAPPORTS ALLONGÉS Secondaires				
REGOLATORE DI TENSIONE	RECTIFIER	RÉGULATEUR DE TENSION				
RUOTA LIBERA	STARTER CLUTCH	ROUE LIBRE				
STATORE	STATOR	STATOR				
VALVOLE LAMELLARI	REED VALVE	CLAPET À LAMELLES		9912550		

PEUGEOT	PEUGEOT	PEUGEOT	PEUGEOT	PEUGEOT	PEUGEOT	PEUGEOT	PEUGEOT	PEUGEOT	PEUGEOT	PEUGEOT	PEUGEOT
LOOXOR	LOOXOR TDSI	LUDIX	LUDIX BLASTER	METAL X	METROPOLIS	RAPIDO	SPEEDAKE	SPEEDFIGHT	SPEEDFIGHT 3	SPEEDFIGHT LC	SQUAB
90-02	02-06	90-02	90-02	90-02	90-02	90-02	90-02	97-04	09-14	97-04	90-02
50cc 2T AC	50cc 2T	50cc 2T AC	50cc 2T LC	50cc 2T AC	50cc 2T AC	50cc 2T AC	50cc 2T AC	50cc 2T AC	50cc 2T AC	50cc 2T LC	50cc 2T AC
Motore Peugeot	A	Motore Peugeot	Motore Peugeot	Motore Peugeot	Motore Peugeot	Motore Peugeot	Motore Peugeot	Motore Peugeot	Motore Peugeot	Motore Peugeot	Motore Peugeot
IM07061				IM07061			IM07061	IM07061		IM07061	IM07061
IM07016				IM07016			IM07016	IM07016		IM07016	IM07016
		9910790					9910790	9910790		9910790	9910790
		9935240 9935370 9935570					9935240 9935570	9935240 9935570		9935240 9935570	9935240 9935570
		CT00741	CT00741								
9910020				9910020			9910020	9910020		9910020	9910020
	CP00219										
9924770		9925830		9924770			9924770	9924770 KT00119	9925830	KT00119	9924770
KT00123				KT00123			KT00123	KT00123			KT00123
9908660		9925800		9908660			9908660	9908660 KT00116	9925800	9919540 KT00116	9908660
KT00058				KT00058			KT00058	KT00058			KT00058
								KK01005		KK01005	
MA00019		MA00019		MA00019			MA00019	MA00019	MA00019	MA00019	MA00019
9912550				9912550	9912550	9912550	9912550	9912550		9912550	9912550

SCOOTER 50cc

SCOOTER 50cc

TOP
- performances -



PEUGEOT PEUGEOT PEUGEOT PEUGEOT

ST	SV GEO	TREKKER	V-CLIC
90-02	90-02	90-02	90-02
50cc 2T AC	50cc 2T AC	50cc 2T AC	50cc 4T AC
Motore Peugeot	Motore Peugeot	Motore Peugeot	Tipo Kymco

IT	EN	FR				
ALBERO MESSA IN MOTO	KICK SHAFT	ARBRE DE DEMARREUR				
ALBERO MOTORE Con Cuscinetti e Paraoli	CRANKSHAFT with bearings and oil seals	VILEBREQUIN doté de Paliers et Joints d'huile			IM07061	IM07061
ALBERO MOTORE Senza Cuscinetti e Paraoli	CRANKSHAFT without bearings and oil seals	VILEBREQUIN sans Paliers et Joints d'huile			IM07016	IM07016
BIELLA	CONROD	BIELLE				
CAMPANA FRIZIONE	CLUTCH HOUSING	CLOCHE EMBRAYAGE				
CENTRALINA AD ANTICIPO FISSO	DIGITAL IGNITION UNIT	ALLUMAGE Fixe				
CENTRALINA AD ANTICIPO VARIABILE 4T	IGNITION UNIT Variable	ALLUMAGE Numérique				
CINGHIA DI TRASMISSIONE TOP	TRANSMISSION BELT TOP PERFORMANCES	COURROIE DE TRANSMISSION TOP PERFORMANCES				9910790
CINGHIA DI TRASMISSIONE Mitsubishi	TRANSMISSION BELT Mitsubishi	COURROIE DE TRANSMISSION Mitsubishi				9935240 9935570
COLLETTORE ASPIRAZIONE	INLET MANIFOLD	COLLECTEUR ASPIRATION				
FRIZIONE CENTRIFUGA Interno Ø 105	CENTRIFUGAL CLUTCH Ø 105	EMBAYAGE CENTRIFUGE Ø 105				
FRIZIONE CENTRIFUGA Interno Ø 107	CENTRIFUGAL CLUTCH Ø 107	EMBAYAGE CENTRIFUGE Ø 107			9910020	9910020
GANASCE FRENO	BRAKE SHOES	MÂCHOIRES FREIN				
GRUPPO TERMICO Ø Standard c/testa	CYLINDER KIT Ø standard with head	CYLINDRE COMPLET Ø Standard avec culasse			9924770	9924770
GRUPPO TERMICO Ø Standard s/testa	CYLINDER KIT Ø standard without head	CYLINDRE COMPLET Ø Standard sans culasse			KT00123	KT00123
GRUPPO TERMICO Ø Magg. c/testa	CYLINDER KIT BIG BORE with head	CYLINDRE COMPLET Ø Majoré avec culasse			9908660	9908660
GRUPPO TERMICO Ø Magg. s/testa	CYLINDER KIT BIG BORE without head	CYLINDRE COMPLET Ø Majoré sans culasse			KT00058	KT00058 9925140 KT00132
GRUPPO TERMICO Modifica da AC a LC	CYLINDER KIT Conversion AC to LC	CYLINDRE COMPLET Modification de AC à LC				
KIT CUSCINETTI DA BANCO	BEARINGS KIT	KIT PALIERS DE VILEBREQUIN				KK01005
KIT REVISIONE POMPA ACQUA	WATER PUMP REPAIR KIT	KIT RÉVISION POMPE À EAU				
MEMBRANA CARBURATORE	CARBURETOR DIAPHRAGM	MEMBRANE CARBURATEUR				
MOTORINO D'AVVIAMENTO	STARTER ENGINE	DÉMARREUR ÉLECTRIQUE				MA00019
PULEGGIA FISSA	VARIATOR SHEAVE FIXED	POULIE FIXE				
RAPPORTI ALLUNGATI Primari	GÉARS KIT Primary	RAPPORTS ALLONGÉS Primaires				
RAPPORTI ALLUNGATI Secondari	GÉARS KIT Secondary	RAPPORTS ALLONGÉS Secondaires				
REGOLATORE DI TENSIONE	RECTIFIER	RÉGULATEUR DE TENSION				
RUOTA LIBERA	STARTER CLUTCH	ROUE LIBRE				
STATORE	STATOR	STATOR				
VALVOLE LAMELLARI	REED VALVE	CLAPET À LAMELLES		9912550	9912550	9912550

PEUGEOT	PEUGEOT	PEUGEOT	PEUGEOT	PGO	PIAGGIO	PIAGGIO	PIAGGIO	PIAGGIO	PIAGGIO	PIAGGIO	PIAGGIO
VIVACITY	X-FIGHT	X-FIGHT LC	ZENITH	BIG MAX	DIESIS	FLY 2T	FLY 2T	FLY 4T	FLY 4T & 25-30 KM/H	FLY 4T 2V	FLY 4T 2V 25-30KM/H
90-02	00-02	00-02	90-02	95-97	01-01	05-07	10-11	05-07	08-11	13-15	12-17
50cc 2T AC	50cc 2T AC	50cc 2T LC	50cc 2T AC	50cc 2T AC	50cc 2T AC	50cc 2T AC	50cc 2T AC	50cc 4T AC	50cc 4T AC	50cc 4T AC	50cc 4T AC
Motore Peugeot	Motore Peugeot	Motore Peugeot	Motore Peugeot	Tipo MY	Motore Piaggio	Motore Piaggio	Motore Piaggio	Motore Piaggio	Motore Piaggio	Motore Piaggio	Motore Piaggio
					CI07494	CI07494	CI07494	CI07494	CI07494		
IM07061	IM07061	IM07061	IM07061		IM07060	IM07060	IM07060				
IM07016	IM07016	IM07016	IM07016		IM07015	IM07015	IM07015	IM07073	IM07073	IM07073	IM07073
					IM07031	IM07031	IM07031				
					9924950	9924950	9924950				
								9926150	9926150		
9910790	9910790				9922030						
9935240 9935570	9935240 9935570				9935830	9935420	9935420	9935480	9935480	9935480	9935480
					CT00727	CT00727	CT00727	CT00737	CT00737		
9910020	9910020		9910020		9910020	9910020	9910020	9910020	9910020		
9924770	9924770	KT00119	9924770	9931140	9914500	9914500	9914500				
KT00123	KT00123	KT00123	KT00123	KT00095	KT00080	KT00080	KT00080				
9908660	9908660	9919540 KT00116	9908660	9931340 KT00087	9931250 KT00086	9931250 KT00086	9931250 KT00086				
KT00058	KT00058	KT00058	KT00058					9925150 KT00133	9925150 KT00133		
				KK01000 KK01002	KK01003 KK01009	KK01003 KK01009	KK01003 KK01009				
								MC12108	MC12108	MC12108	MC12108
MA00019	MA00019	MA00019	MA00019		MA00002	MA00002	MA00002	MA00015	MA00015		
					PL04058	PL04058	PL04058	PL04058	PL04058	PL04058	PL04058
					RE00012	RE00012	RE00012	RE00018			
					RL00040	RL00040	RL00040	RL00039	RL00039		
								ST00004	ST00004		
9912550	9912550	9912550	9912550		9910930	9910930	9910930				

SCOOTER 50cc

SCOOTER 50cc

TOP
- performances -



PIAGGIO	PIAGGIO	PIAGGIO	PIAGGIO
FLY 4T 4V	FLY 4T MOTO-RE-CHN	FREE	FREE DELIVERY
12-13	06-07	92-94	00-01
50cc 4T-4V AC	50cc 4T AC	50cc 2T AC	50cc 2T AC
Motore Piaggio	Motore Piaggio	Motore Piaggio	Motore Piaggio

IT	EN	FR					
ALBERO MESSA IN MOTO	KICK SHAFT	ARBRE DE DEMARREUR			CI07494	CI07494	
ALBERO MOTORE Con Cuscinetti e Paraoli	CRANKSHAFT with bearings and oil seals	VILEBREQUIN doté de Paliers et Joints d'huile				IM07060	
ALBERO MOTORE Senza Cuscinetti e Paraoli	CRANKSHAFT without bearings and oil seals	VILEBREQUIN sans Paliers et Joints d'huile		IM07073	IM07073	IM07015	IM07015
BIELLA	CONROD	BIELLE				IM07031	IM07031
CAMPANA FRIZIONE	CLUTCH HOUSING	CLOCHE EMBRAYAGE				9924950	9924950
CENTRALINA AD ANTICIPO FISSO	DIGITAL IGNITION UNIT	ALLUMAGE Fixe				9924870	9924870
CENTRALINA AD ANTICIPO VARIABILE 4T	IGNITION UNIT Variable	ALLUMAGE Numérique				9926150	
CINGHIA DI TRASMISSIONE TOP	TRANSMISSION BELT TOP PERFORMANCES	COURROIE DE TRANSMISSION TOP PERFORMANCES				9913280	9922030
CINGHIA DI TRASMISSIONE Mitsubishi	TRANSMISSION BELT Mitsubishi	COURROIE DE TRANSMISSION Mitsubishi		9935480	9935480	9935800	9935830
COLLETTORE ASPIRAZIONE	INLET MANIFOLD	COLLECTEUR ASPIRATION				CT00737	CT00727
FRIZIONE CENTRIFUGA Interno Ø 105	CENTRIFUGAL CLUTCH Ø 105	EMBAYAGE CENTRIFUGE Ø 105					
FRIZIONE CENTRIFUGA Interno Ø 107	CENTRIFUGAL CLUTCH Ø 107	EMBAYAGE CENTRIFUGE Ø 107				9910020	9910020
GANASCE FRENO	BRAKE SHOES	MÂCHOIRES FREIN					
GRUPPO TERMICO Ø Standard c/testa	CYLINDER KIT Ø standard with head	CYLINDRE COMPLET Ø Standard avec culasse				9914500	9914500
GRUPPO TERMICO Ø Standard s/testa	CYLINDER KIT Ø standard without head	CYLINDRE COMPLET Ø Standard sans culasse				KT00080	KT00080
GRUPPO TERMICO Ø Magg. c/testa	CYLINDER KIT BIG BORE with head	CYLINDRE COMPLET Ø Majoré avec culasse				9931250	9931250
GRUPPO TERMICO Ø Magg. s/testa	CYLINDER KIT BIG BORE without head	CYLINDRE COMPLET Ø Majoré sans culasse		9928300	9925150	KT00086	KT00086
GRUPPO TERMICO Modifica da AC a LC	CYLINDER KIT Conversion AC to LC	CYLINDRE COMPLET Modification de AC à LC					
KIT CUSCINETTI DA BANCO	BEARINGS KIT	KIT PALIERS DE VILEBREQUIN				KK01003	KK01003
KIT REVISIONE POMPA ACQUA	WATER PUMP REPAIR KIT	KIT RÉVISION POMPE À EAU					
MEMBRANA CARBURATORE	CARBURETOR DIAPHRAGM	MEMBRANE CARBURATEUR				MC12108	
MOTORINO D'AVVIAMENTO	STARTER ENGINE	DÉMARREUR ÉLECTRIQUE				MA00015	MA00002
PULEGGIA FISSA	VARIATOR SHEAVE FIXED	POULIE FIXE		PL04058	PL04058	PL04058	PL04058
RAPPORTI ALLUNGATI Primari	GÉARS KIT Primary	RAPPORTS ALLONGÉS Primaires					
RAPPORTI ALLUNGATI Secondari	GÉARS KIT Secondary	RAPPORTS ALLONGÉS Secondaires					
REGOLATORE DI TENSIONE	RECTIFIER	RÉGULATEUR DE TENSION				RE00018	RE00012
RUOTA LIBERA	STARTER CLUTCH	ROUE LIBRE				RL00039	RL00040
STATORE	STATOR	STATOR				ST00004	
VALVOLE LAMELLARI	REED VALVE	CLAPET À LAMELLES				9910930	9910930

PIAGGIO	PIAGGIO	PIAGGIO	PIAGGIO	PIAGGIO	PIAGGIO	PIAGGIO	PIAGGIO	PIAGGIO	PIAGGIO	PIAGGIO	PIAGGIO
FREE FL	LIBERTY	LIBERTY 2T	LIBERTY 2T	LIBERTY 2T PTT EU2	LIBERTY 2T RST	LIBERTY 2T SPORT	LIBERTY 2T SPORT	LIBERTY 4T	LIBERTY 4T	LIBERTY 4T 3V 25 KM/H	LIBERTY 4T 3V IE
95-02	97-05	06-06	07-08	04-05	04-04	06-06	07-08	00-02	05-08	16-16	15-17
50cc 2T AC	50cc 2T AC	50cc 2T AC	50cc 2T AC	50cc 2T AC	50cc 2T AC	50cc 2T AC	50cc 2T AC	50cc 4T AC	50cc 4T AC	50cc 4T-3V AC	50cc 4T-3V AC
Motore Piaggio	Motore Piaggio	Motore Piaggio	Motore Piaggio	Motore Piaggio	Motore Piaggio	Motore Piaggio	Motore Piaggio	Motore Piaggio	Motore Piaggio	Motore Piaggio	Motore Piaggio
CI07494	CI07494	CI07494	CI07494	CI07494	CI07494	CI07494	CI07494	CI07494	CI07494		
IM07060	IM07060	IM07060	IM07060	IM07060	IM07060	IM07060	IM07060				
IM07015	IM07015	IM07015	IM07015	IM07015	IM07015	IM07015	IM07015	IM07073	IM07073	IM07073	IM07073
IM07031	IM07031	IM07031	IM07031	IM07031	IM07031	IM07031	IM07031				
9924950	9924950	9924950	9924950	9924950	9924950	9924950	9924950				9924950
9924870	9924870										
								9926150	9926150		
9913280											
9935800	9935420	9935420	9935420	9935420	9935420	9935420	9935420	9935420	9935420	9935420	9935420
CT00727	CT00727	CT00727	CT00727	CT00727	CT00727	CT00727	CT00727	CT00738	CT00737		
	9910020	9910020	9910020	9910020	9910020	9910020	9910020	9910020	9910020		9910020
9914500	9914500	9914500	9914500	9914500	9914500	9914500	9914500				
KT00080	KT00080	KT00080	KT00080	KT00080	KT00080	KT00080	KT00080				
9931250 KT00086	9931250 KT00086	9931250 KT00086	9931250 KT00086	9931250 KT00086	9931250 KT00086	9931250 KT00086	9931250 KT00086				
								9925150 KT00133	9925150 KT00133		
KK01003 KK01009	KK01003 KK01009	KK01003 KK01009	KK01003 KK01009	KK01003 KK01009	KK01003 KK01009	KK01003 KK01009	KK01003 KK01009				
								MC12108	MC12108		
MA00002	MA00002	MA00002	MA00002	MA00002	MA00002	MA00002	MA00002	MA00015	MA00015		
PL04058	PL04058	PL04058	PL04058	PL04058	PL04058	PL04058	PL04058	PL04058	PL04058	PL04058	PL04058
	RE00012	RE00012	RE00012	RE00012	RE00012	RE00012	RE00012	RE00018	RE00018		
RL00040	RL00040	RL00040	RL00040	RL00040	RL00040	RL00040	RL00040	RL00039	RL00039		RL00039
								ST00004	ST00004		ST00004
9910930	9910930	9910930	9910930	9910930	9910930	9910930	9910930				

SCOOTER 50cc

SCOOTER 50cc

TOP
- performances -



PIAGGIO	PIAGGIO	PIAGGIO	PIAGGIO
LIBERTY 4T 3V IE E4	LIBERTY 4T DELIVERY - SINGLE	LIBERTY 4T DELIVERY TNT	LIBERTY 4T IGET CORPORATE E4
17-18	10-14	09-09	18-20
50cc 4T-3V AC	50cc 4T AC	50cc 4T AC	50cc 4T-3V AC
Motore Piaggio	Motore Piaggio	Motore Piaggio	Motore Piaggio

IT	EN	FR				
ALBERO MESSA IN MOTO	KICK SHAFT	ARBRE DE DEMARREUR				
ALBERO MOTORE Con Cuscinetti e Paraoli	CRANKSHAFT with bearings and oil seals	VILEBREQUIN doté de Paliers et Joints d'huile				
ALBERO MOTORE Senza Cuscinetti e Paraoli	CRANKSHAFT without bearings and oil seals	VILEBREQUIN sans Paliers et Joints d'huile		IM07073	IM07073	IM07073
BIELLA	CONROD	BIELLE				
CAMPANA FRIZIONE	CLUTCH HOUSING	CLOCHE EMBRAYAGE		9924950		
CENTRALINA AD ANTICIPO FISSO	DIGITAL IGNITION UNIT	ALLUMAGE Fixe				
CENTRALINA AD ANTICIPO VARIABILE 4T	IGNITION UNIT Variable	ALLUMAGE Numérique		9926150	9926150	
CINGHIA DI TRASMISSIONE TOP	TRANSMISSION BELT TOP PERFORMANCES	COURROIE DE TRANSMISSION TOP PERFORMANCES				
CINGHIA DI TRASMISSIONE Mitsubishi	TRANSMISSION BELT Mitsubishi	COURROIE DE TRANSMISSION Mitsubishi		9935420	9935420	9935420
COLLETTORE ASPIRAZIONE	INLET MANIFOLD	COLLECTEUR ASPIRATION			CT00737	CT00737
FRIZIONE CENTRIFUGA Interno Ø 105	CENTRIFUGAL CLUTCH Ø 105	EMBAYAGE CENTRIFUGE Ø 105				
FRIZIONE CENTRIFUGA Interno Ø 107	CENTRIFUGAL CLUTCH Ø 107	EMBAYAGE CENTRIFUGE Ø 107		9910020	9910020	9910020
GANASCE FRENO	BRAKE SHOES	MÂCHOIRES FREIN				
GRUPPO TERMICO Ø Standard c/testa	CYLINDER KIT Ø standard with head	CYLINDRE COMPLET Ø Standard avec culasse				
GRUPPO TERMICO Ø Standard s/testa	CYLINDER KIT Ø standard without head	CYLINDRE COMPLET Ø Standard sans culasse				
GRUPPO TERMICO Ø Magg. c/testa	CYLINDER KIT BIG BORE with head	CYLINDRE COMPLET Ø Majoré avec culasse				
GRUPPO TERMICO Ø Magg. s/testa	CYLINDER KIT BIG BORE without head	CYLINDRE COMPLET Ø Majoré sans culasse		9925150 KT00133	9925150 KT00133	9928300
GRUPPO TERMICO Modifica da AC a LC	CYLINDER KIT Conversion AC to LC	CYLINDRE COMPLET Modification de AC à LC				
KIT CUSCINETTI DA BANCO	BEARINGS KIT	KIT PALIERS DE VILEBREQUIN				
KIT REVISIONE POMPA ACQUA	WATER PUMP REPAIR KIT	KIT RÉVISION POMPE À EAU				
MEMBRANA CARBURATORE	CARBURETOR DIAPHRAGM	MEMBRANE CARBURATEUR			MC12108	MC12108
MOTORINO D'AVVIAMENTO	STARTER ENGINE	DÉMARREUR ÉLECTRIQUE			MA00015	MA00015
PULEGGIA FISSA	VARIATOR SHEAVE FIXED	POULIE FIXE		PL04058	PL04058	PL04058
RAPPORTI ALLUNGATI Primari	GÉARS KIT Primary	RAPPORTS ALLONGÉS Primaires				
RAPPORTI ALLUNGATI Secondari	GÉARS KIT Secondary	RAPPORTS ALLONGÉS Secondaires				
REGOLATORE DI TENSIONE	RECTIFIER	RÉGULATEUR DE TENSION			RE00018	RE00018
RUOTA LIBERA	STARTER CLUTCH	ROUE LIBRE		RL00039	RL00039	RL00039
STATORE	STATOR	STATOR		ST00004	ST00004	ST00004
VALVOLE LAMELLARI	REED VALVE	CLAPET À LAMELLES				

PIAGGIO	PIAGGIO	PIAGGIO	PIAGGIO	PIAGGIO	PIAGGIO	PIAGGIO	PIAGGIO	PIAGGIO	PIAGGIO	PIAGGIO	PIAGGIO
LIBERTY 4T PTT (DEU)	LIBERTY 4T PTT - DOUBLE - NEXIVE	LIBERTY 4T RST	LIBERTY 4T SPORT	LIBERTY 4T SPORT	LIBERTY IGET 4T 3V 25KM/H	LIBERTY IGET 4T 3V IE	LIBERTY IGET 4T 3V IE E4 EMEA	LIBERTY IGET 4T 3V IE E4 EMEA 25KM/H	LIBERTY MOC 2T & ELLE	LIBERTY MOC 4T & ELLE	NRG
07-12	09-17	04-04	06-06	07-08	16-16	15-17	17-19	17-19	09-13	09-16	94-96
50cc 4T AC	50cc 4T AC	50cc 4T AC	50cc 4T AC	50cc 4T AC	50cc 4T-3V AC	50cc 4T-3V AC	50cc 4T-3V AC	50cc 4T-3V AC	50cc 2T AC	50cc 4T AC	50cc 2T LC
Motore Piaggio	Motore Piaggio	Motore Piaggio	Motore Piaggio	Motore Piaggio	Motore Piaggio	Motore Piaggio	Motore Piaggio	Motore Piaggio	Motore Piaggio	Motore Piaggio	Motore Piaggio
	CI07494	CI07494	CI07494	CI07494					CI07494		CI07494
									IM07060		IM07060
IM07073	IM07073	IM07073	IM07073	IM07073	IM07073	IM07073			IM07015	IM07073	IM07015
									IM07031		IM07031
									9924950		9924950
	9926150	9926150	9926150	9926150						9926150	
											9913280
9935420	9935420	9935420	9935420	9935420	9935420	9935420	9935420	9935420	9935420	9935420	9935800
	CT00737	CT00738	CT00737	CT00737					CT00727	CT00737	CT00727
	9910020	9910020	9910020	9910020			9910020		9910020	9910020	9910020
									9914500		9916580 KT00112
									KT00080		
									9931250 KT00086		9931270 KT00097
	9925150 KT00133	9925150 KT00133	9925150 KT00133	9925150 KT00133	9928300	9928300	9928300	9928300		9925150 KT00133	
									KK01003 KK01009		KK01003 KK01009
											AA00796
MC12108	MC12108	MC12108	MC12108	MC12108						MC12108	
	MA00015	MA00015	MA00015	MA00015					MA00015		MA00002
PL04058	PL04058	PL04058	PL04058	PL04058	PL04058	PL04058			PL04058	PL04058	PL04058
	RE00018	RE00018	RE00018	RE00018					RE00012	RE00018	
	RL00039	RL00039	RL00039	RL00039					RL00039		RL00040
	ST00004	ST00004	ST00004	ST00004						ST00004	
									9910930		9910930

SCOOTER 50cc

SCOOTER 50cc

TOP
- performances -



PIAGGIO	PIAGGIO	PIAGGIO	PIAGGIO
NRG EXTREME LC	NRG MC3	NRG POWER DD	NRG POWER DD
99-00	01-04	05-05	06-06
50cc 2T LC	50cc 2T LC	50cc 2T LC	50cc 2T LC
Motore Piaggio	Motore Piaggio	Motore Piaggio	Motore Piaggio
CI07494	CI07494	CI07494	CI07494
IM07060	IM07060	IM07060	IM07060
IM07015	IM07015	IM07015	IM07015
IM07031	IM07031	IM07031	IM07031
9924950	9924950	9924950	9924950
9924870	9924870		
	9922030	9922030	9922030
	9935830	9935830	9935830
CT00727	CT00727	CT00727	CT00727
9916580 KT00112	9916580 KT00112	9916580 KT00112	9916580 KT00112
9931270 KT00097	9931270 KT00097	9931270 KT00097	9931270 KT00097
KK01003 KK01009	KK01003 KK01009	KK01003 KK01009	KK01003 KK01009
AA00796	AA00796	AA00796	AA00796
MA00002	MA00002	MA00002	MA00002
PL04058	PL04058	PL04058	PL04058
RE00012	RE00012	RE00012	RE00012
RL00040	RL00040	RL00040	RL00040
9910930	9910930	9910930	9910930

IT	EN	FR
ALBERO MESSA IN MOTO	KICK SHAFT	ARBRE DE DEMARREUR
ALBERO MOTORE Con Cuscinetti e Paraoli	CRANKSHAFT with bearings and oil seals	VILEBREQUIN doté de Paliers et Joints d'huile
ALBERO MOTORE Senza Cuscinetti e Paraoli	CRANKSHAFT without bearings and oil seals	VILEBREQUIN sans Paliers et Joints d'huile
BIELLA	CONROD	BIELLE
CAMPANA FRIZIONE	CLUTCH HOUSING	CLOCHE EMBRAYAGE
CENTRALINA AD ANTICIPO FISSO	DIGITAL IGNITION UNIT	ALLUMAGE Fixe
CENTRALINA AD ANTICIPO VARIABILE 4T	IGNITION UNIT Variable	ALLUMAGE Numérique
CINGHIA DI TRASMISSIONE TOP	TRANSMISSION BELT TOP PERFORMANCES	COURROIE DE TRANSMISSION TOP PERFORMANCES
CINGHIA DI TRASMISSIONE Mitsubishi	TRANSMISSION BELT Mitsubishi	COURROIE DE TRANSMISSION Mitsubishi
COLLETTORE ASPIRAZIONE	INLET MANIFOLD	COLLECTEUR ASPIRATION
FRIZIONE CENTRIFUGA Interno Ø 105	CENTRIFUGAL CLUTCH Ø 105	EMBAYAGE CENTRIFUGE Ø 105
FRIZIONE CENTRIFUGA Interno Ø 107	CENTRIFUGAL CLUTCH Ø 107	EMBAYAGE CENTRIFUGE Ø 107
GANASCE FRENO	BRAKE SHOES	MÂCHOIRES FREIN
GRUPPO TERMICO Ø Standard c/testa	CYLINDER KIT Ø standard with head	CYLINDRE COMPLET Ø Standard avec culasse
GRUPPO TERMICO Ø Standard s/testa	CYLINDER KIT Ø standard without head	CYLINDRE COMPLET Ø Standard sans culasse
GRUPPO TERMICO Ø Magg. c/testa	CYLINDER KIT BIG BORE with head	CYLINDRE COMPLET Ø Majoré avec culasse
GRUPPO TERMICO Ø Magg. s/testa	CYLINDER KIT BIG BORE without head	CYLINDRE COMPLET Ø Majoré sans culasse
GRUPPO TERMICO Modifica da AC a LC	CYLINDER KIT Conversion AC to LC	CYLINDRE COMPLET Modification de AC à LC
KIT CUSCINETTI DA BANCO	BEARINGS KIT	KIT PALIERS DE VILEBREQUIN
KIT REVISIONE POMPA ACQUA	WATER PUMP REPAIR KIT	KIT RÉVISION POMPE À EAU
MEMBRANA CARBURATORE	CARBURETOR DIAPHRAGM	MEMBRANE CARBURATEUR
MOTORINO D'AVVIAMENTO	STARTER ENGINE	DÉMARREUR ÉLECTRIQUE
PULEGGIA FISSA	VARIATOR SHEAVE FIXED	POULIE FIXE
RAPPORTI ALLUNGATI Primari	GÉARS KIT Primary	RAPPORTS ALLONGÉS Primaires
RAPPORTI ALLUNGATI Secondari	GÉARS KIT Secondary	RAPPORTS ALLONGÉS Secondaires
REGOLATORE DI TENSIONE	RECTIFIER	RÉGULATEUR DE TENSION
RUOTA LIBERA	STARTER CLUTCH	ROUE LIBRE
STATORE	STATOR	STATOR
VALVOLE LAMELLARI	REED VALVE	CLAPET À LAMELLES

PIAGGIO	PIAGGIO	PIAGGIO	PIAGGIO	PIAGGIO	PIAGGIO	PIAGGIO	PIAGGIO	PIAGGIO	PIAGGIO	PIAGGIO	PIAGGIO
NRG POWER DD	NRG POWER DD SERIE SPECIALE	NRG POWER DT	NRG POWER DT	NRG POWER DT SERIE SPECIALE	NRG POWER PUREJET	NRG POWER PUREJET	NRG POWER PUREJET	NRG POWER PUREJET	NRG PUREJET	NRG PUREJET	NRG RST MC2
07-17	07-12	06-06	07-15	07-08	04-05	06-06	07-09	10-11	02-04	10-10	96-98
50cc 2T LC	50cc 2T LC	50cc 2T AC	50cc 2T AC	50cc 2T AC	50cc 2T-IE LC	50cc 2T-IE LC	50cc 2T-IE LC	50cc 2T-IE LC	50cc 2T-IE LC	50cc 2T-IE LC	50cc 2T LC
Motore Piaggio	Motore Piaggio	Motore Piaggio	Motore Piaggio	Motore Piaggio	Motore Piaggio	Motore Piaggio	Motore Piaggio	Motore Piaggio	Motore Piaggio	Motore Piaggio	Motore Piaggio
CI07494	CI07494	CI07494	CI07494	CI07494							CI07494
IM07060	IM07060	IM07060	IM07060	IM07060							IM07060
IM07015	IM07015	IM07015	IM07015	IM07015	IM07064	IM07064	IM07064	IM07064	IM07064	IM07064	IM07015
IM07031	IM07031	IM07031	IM07031	IM07031							IM07031
9924950	9924950	9924950	9924950	9924950	9924950	9924950	9924950	9924950	9924950	9924950	9924950
											9924870
9922030	9922030	9922030	9922030	9922030					9922030		9913280
9935830	9935830	9935830	9935830	9935830					9935830		9935800
CT00727	CT00727	CT00727	CT00727	CT00727							CT00727
		9910020	9910020	9910020							9910020
9916580 KT00112	9916580 KT00112	9914500 KT00080	9914500 KT00080	9914500 KT00080	9916580 KT00112	9916580 KT00112	9916580 KT00112	9916580 KT00112	9916580 KT00112	9916580 KT00112	9916580 KT00112
9931270 KT00097	9931270 KT00097	9931250 KT00086	9931250 KT00086	9931250 KT00086	9931270 KT00097	9931270 KT00097	9931270 KT00097	9931270 KT00097	9931270 KT00097	9931270 KT00097	9931270 KT00097
KK01003 KK01009	KK01003 KK01009	KK01003 KK01009	KK01003 KK01009	KK01003 KK01009	KK01003 KK01009	KK01003 KK01009	KK01003 KK01009	KK01003 KK01009	KK01003 KK01009	KK01003 KK01009	KK01003 KK01009
AA00796	AA00796				AA00796	AA00796	AA00796	AA00796	AA00796	AA00796	AA00796
MA00002	MA00002	MA00002	MA00002	MA00002	MA00015	MA00015	MA00015	MA00015	MA00015	MA00015	MA00002
PL04058	PL04058	PL04058	PL04058	PL04058	PL04058	PL04058	PL04058	PL04058	PL04058	PL04058	PL04058
RE00012	RE00012	RE00012	RE00012	RE00012							
RL00040	RL00040	RL00040	RL00040	RL00040	RL00039	RL00039	RL00039	RL00039	RL00039	RL00039	RL00040
9910930	9910930	9910930	9910930	9910930	9910930	9910930	9910930	9910930	9910930	9910930	9910930

SCOOTER 50cc

SCOOTER 50cc

TOP
- performances -



PIAGGIO PIAGGIO PIAGGIO PIAGGIO

NTT QUARTZ SFERA SFERA MA-QUILLAGE 2

95-96 92-96 91-93 94-94

50cc 2T LC 50cc 2T LC 50cc 2T AC 50cc 2T AC

Motore Piaggio Motore Piaggio Motore Piaggio Motore Piaggio

IT	EN	FR					
ALBERO MESSA IN MOTO	KICK SHAFT	ARBRE DE DEMARREUR		CI07494	CI07494	CI07494	CI07494
ALBERO MOTORE Con Cuscinetti e Paraoli	CRANKSHAFT with bearings and oil seals	VILEBREQUIN doté de Paliers et Joints d'huile		IM07060	IM07060	IM07060	IM07060
ALBERO MOTORE Senza Cuscinetti e Paraoli	CRANKSHAFT without bearings and oil seals	VILEBREQUIN sans Paliers et Joints d'huile		IM07015	IM07015	IM07015	IM07015
BIELLA	CONROD	BIELLE		IM07031	IM07031	IM07031	IM07031
CAMPANA FRIZIONE	CLUTCH HOUSING	CLOCHE EMBRAYAGE		9924950	9924950	9924950	9924950
CENTRALINA AD ANTICIPO FISSO	DIGITAL IGNITION UNIT	ALLUMAGE Fixe		9924870	9924870	9924870	9924870
CENTRALINA AD ANTICIPO VARIABILE 4T	IGNITION UNIT Variable	ALLUMAGE Numérique					
CINGHIA DI TRASMISSIONE TOP	TRANSMISSION BELT TOP PERFORMANCES	COURROIE DE TRANSMISSION TOP PERFORMANCES		9913280	9913350	9913360	
CINGHIA DI TRASMISSIONE Mitsubishi	TRANSMISSION BELT Mitsubishi	COURROIE DE TRANSMISSION Mitsubishi		9935800	9935810		9935810
COLLETTORE ASPIRAZIONE	INLET MANIFOLD	COLLECTEUR ASPIRATION		CT00727	CT00727	CT00727	CT00727
FRIZIONE CENTRIFUGA Interno Ø 105	CENTRIFUGAL CLUTCH Ø 105	EMBAYAGE CENTRIFUGE Ø 105					
FRIZIONE CENTRIFUGA Interno Ø 107	CENTRIFUGAL CLUTCH Ø 107	EMBAYAGE CENTRIFUGE Ø 107		9910020	9910020	9910020	9910020
GANASCE FRENO	BRAKE SHOES	MÂCHOIRES FREIN					
GRUPPO TERMICO Ø Standard c/testa	CYLINDER KIT Ø standard with head	CYLINDRE COMPLET Ø Standard avec culasse		9916580 KT00112	9916580 KT00112	9914500	9914500
GRUPPO TERMICO Ø Standard s/testa	CYLINDER KIT Ø standard without head	CYLINDRE COMPLET Ø Standard sans culasse				KT00080	KT00080
GRUPPO TERMICO Ø Magg. c/testa	CYLINDER KIT BIG BORE with head	CYLINDRE COMPLET Ø Majoré avec culasse		9931270 KT00097	9931270 KT00097	9931250 KT00086	9931250 KT00086
GRUPPO TERMICO Ø Magg. s/testa	CYLINDER KIT BIG BORE without head	CYLINDRE COMPLET Ø Majoré sans culasse					
GRUPPO TERMICO Modifica da AC a LC	CYLINDER KIT Conversion AC to LC	CYLINDRE COMPLET Modification de AC à LC					
KIT CUSCINETTI DA BANCO	BEARINGS KIT	KIT PALIERS DE VILEBREQUIN		KK01003 KK01009	KK01003 KK01009	KK01003 KK01009	KK01003 KK01009
KIT REVISIONE POMPA ACQUA	WATER PUMP REPAIR KIT	KIT RÉVISION POMPE À EAU		AA00796	AA00796		
MEMBRANA CARBURATORE	CARBURETOR DIAPHRAGM	MEMBRANE CARBURATEUR					
MOTORINO D'AVVIAMENTO	STARTER ENGINE	DÉMARREUR ÉLECTRIQUE		MA00002	MA00002	MA00002	MA00002
PULEGGIA FISSA	VARIATOR SHEAVE FIXED	POULIE FIXE		PL04058	PL04058	PL04058	PL04058
RAPPORTI ALLUNGATI Primari	GÉARS KIT Primary	RAPPORTS ALLONGÉS Primaires					
RAPPORTI ALLUNGATI Secondari	GÉARS KIT Secondary	RAPPORTS ALLONGÉS Secondaires					
REGOLATORE DI TENSIONE	RECTIFIER	RÉGULATEUR DE TENSION					
RUOTA LIBERA	STARTER CLUTCH	ROUE LIBRE		RL00040	RL00040	RL00040	RL00040
STATORE	STATOR	STATOR					
VALVOLE LAMELLARI	REED VALVE	CLAPET À LAMELLES		9910930	9910930	9910930	9910930

PIAGGIO	PIAGGIO	PIAGGIO	PIAGGIO	PIAGGIO	PIAGGIO	PIAGGIO	PIAGGIO	PIAGGIO	PIAGGIO	PIAGGIO	PIAGGIO
SFERA RST	TYPHOON	TYPHOON	TYPHOON	TYPHOON 2T E2	TYPHOON 2T E3 CH	TYPHOON 2T EURO4	VESPA ET2	VESPA ET2	VESPA ET2 INIEZIONE	VESPA ET4	VESPA FL
95-97	01-04	05-08	09-11	10-12	11-11	18-18	97-98	98-05	97-00	00-05	90-90
50cc 2T AC	50cc 2T AC	50cc 2T AC	50cc 2T AC	50cc 2T AC	50cc 2T AC	50cc 4T-3V AC	50cc 2T AC	50cc 2T AC	50cc 2T AC	50cc 4T AC	50cc 2T AC
Motore Piaggio	Motore Piaggio	Motore Piaggio	Motore Piaggio	Motore Piaggio	Motore Piaggio	Motore Piaggio	Motore Piaggio	Motore Piaggio	Motore Piaggio	Motore Piaggio	
CI07494	CI07494	CI07494	CI07494	CI07494	CI07494		CI07494	CI07494	CI07494	CI07494	
IM07060	IM07060	IM07060	IM07060	IM07060	IM07060		IM07060	IM07060	IM07060		
IM07015	IM07015	IM07015	IM07015	IM07015	IM07015		IM07015	IM07015	IM07015	IM07073	IM07007 IM07008
IM07031	IM07031	IM07031	IM07031	IM07031	IM07031		IM07031	IM07031	IM07031		
9924950	9924950	9924950	9924950	9924950	9924950		9924950	9924950	9924950		
9924870							9924870	9924870			
										9926150	
9913350	9922030	9922030	9922030						9922040	9922040	
9935810	9935830	9935830	9935830	9935420	9935420	9935420	9935810	9935840	9935840	9935840	
CT00727	CT00727	CT00727	CT00727	CT00727	CT00727		CT00727	CT00727	CT00727	CT00738	
9910020				9910020	9910020		9910020	9910020		9910020	
9914500	9914500	9914500	9914500	9914500	9914500		9914500	9914500	9914500		
KT00080	KT00080	KT00080	KT00080	KT00080	KT00080		KT00080	KT00080	KT00080		KT00010
9931250 KT00086	9931250 KT00086	9931250 KT00086	9931250 KT00086	9931250 KT00086	9931250 KT00086		9931250 KT00086	9931250 KT00086	9931250 KT00086		
										9925150 KT00133	
KK01003 KK01009	KK01003 KK01009	KK01003 KK01009	KK01003 KK01009	KK01003 KK01009	KK01003 KK01009		KK01003 KK01009	KK01003 KK01009	KK01003 KK01009		KK01012
										MC12108	
MA00002	MA00002	MA00002	MA00002	MA00002	MA00002		MA00002	MA00002	MA00002	MA00015	MA00023
PL04058	PL04058	PL04058	PL04058	PL04058	PL04058		PL04058	PL04058	PL04058	PL04058	
	RE00012	RE00012	RE00012	RE00012	RE00012					RE00018	
RL00040	RL00040	RL00040	RL00040	RL00040	RL00040		RL00040	RL00040	RL00040	RL00039	
										ST00004	
9910930	9910930	9910930	9910930	9910930	9910930		9910930	9910930	9910930		

SCOOTER 50cc

SCOOTER 50cc

TOP
- performances -



PIAGGIO	PIAGGIO	PIAGGIO	PIAGGIO
VESPA FL2 AUTOMATICA	VESPA FL2 HP	VESPA LX 2T	VESPA LX 2T
90-91	91-97	05-08	09-13
50cc 2T AC	50cc 2T AC	50cc 2T AC	50cc 2T AC
		Motore Piaggio	Motore Piaggio

IT	EN	FR				
ALBERO MESSA IN MOTO	KICK SHAFT	ARBRE DE DEMARREUR				CI07494
ALBERO MOTORE Con Cuscinetti e Paraoli	CRANKSHAFT with bearings and oil seals	VILEBREQUIN doté de Paliers et Joints d'huile				IM07060
ALBERO MOTORE Senza Cuscinetti e Paraoli	CRANKSHAFT without bearings and oil seals	VILEBREQUIN sans Paliers et Joints d'huile				IM07015
BIELLA	CONROD	BIELLE				IM07031
CAMPANA FRIZIONE	CLUTCH HOUSING	CLOCHE EMBRAYAGE				9924950
CENTRALINA AD ANTICIPO FISSO	DIGITAL IGNITION UNIT	ALLUMAGE Fixe				
CENTRALINA AD ANTICIPO VARIABILE 4T	IGNITION UNIT Variable	ALLUMAGE Numérique				
CINGHIA DI TRASMISSIONE TOP	TRANSMISSION BELT TOP PERFORMANCES	COURROIE DE TRANSMISSION TOP PERFORMANCES				9922040
CINGHIA DI TRASMISSIONE Mitsubishi	TRANSMISSION BELT Mitsubishi	COURROIE DE TRANSMISSION Mitsubishi				9935840
COLLETTORE ASPIRAZIONE	INLET MANIFOLD	COLLECTEUR ASPIRATION				CT00727
FRIZIONE CENTRIFUGA Interno Ø 105	CENTRIFUGAL CLUTCH Ø 105	EMBAYAGE CENTRIFUGE Ø 105				
FRIZIONE CENTRIFUGA Interno Ø 107	CENTRIFUGAL CLUTCH Ø 107	EMBAYAGE CENTRIFUGE Ø 107				
GANASCE FRENO	BRAKE SHOES	MÂCHOIRES FREIN				
GRUPPO TERMICO Ø Standard c/testa	CYLINDER KIT Ø standard with head	CYLINDRE COMPLET Ø Standard avec culasse				9914500
GRUPPO TERMICO Ø Standard s/testa	CYLINDER KIT Ø standard without head	CYLINDRE COMPLET Ø Standard sans culasse			KT00010	KT00080
GRUPPO TERMICO Ø Magg. c/testa	CYLINDER KIT BIG BORE with head	CYLINDRE COMPLET Ø Majoré avec culasse				9931250 KT00086
GRUPPO TERMICO Ø Magg. s/testa	CYLINDER KIT BIG BORE without head	CYLINDRE COMPLET Ø Majoré sans culasse				
GRUPPO TERMICO Modifica da AC a LC	CYLINDER KIT Conversion AC to LC	CYLINDRE COMPLET Modification de AC à LC				
KIT CUSCINETTI DA BANCO	BEARINGS KIT	KIT PALIERS DE VILEBREQUIN				KK01012
KIT REVISIONE POMPA ACQUA	WATER PUMP REPAIR KIT	KIT RÉVISION POMPE À EAU				
MEMBRANA CARBURATORE	CARBURETOR DIAPHRAGM	MEMBRANE CARBURATEUR				
MOTORINO D'AVVIAMENTO	STARTER ENGINE	DÉMARREUR ÉLECTRIQUE		MA00023	MA00023	MA00002
PULEGGIA FISSA	VARIATOR SHEAVE FIXED	POULIE FIXE				PL04058
RAPPORTI ALLUNGATI Primari	GÉARS KIT Primary	RAPPORTS ALLONGÉS Primaires				
RAPPORTI ALLUNGATI Secondari	GÉARS KIT Secondary	RAPPORTS ALLONGÉS Secondaires				
REGOLATORE DI TENSIONE	RECTIFIER	RÉGULATEUR DE TENSION				RE00012
RUOTA LIBERA	STARTER CLUTCH	ROUE LIBRE				RL00040
STATORE	STATOR	STATOR				
VALVOLE LAMELLARI	REED VALVE	CLAPET À LAMELLES				9910930

PIAGGIO	PIAGGIO	PIAGGIO	PIAGGIO	PIAGGIO	PIAGGIO	PIAGGIO	PIAGGIO	PIAGGIO	PIAGGIO	PIAGGIO	PIAGGIO
VESPA LX 2T TOURING & 30KM	VESPA LX 4T	VESPA LX 4T 4V	VESPA LX 4T 4V TOURING	VESPA LXV 2T	VESPA LXV 2T NAVY	VESPA N	VESPA PK	VESPA PK AUTOMATICA	VESPA PK XL	VESPA PK XL PLURIMATIC	VESPA PK XL RUSH
10-13	05-09	09-13	10-13	06-09	08-08	89-90	82-84	84-89	85-88	85-90	88-89
50cc 2T AC	50cc 4T AC	50cc 4T-4V AC	50cc 4T-4V AC	50cc 2T AC	50cc 2T AC	50cc 2T AC	50cc 2T AC	50cc 2T AC	50cc 2T AC	50cc 2T AC	50cc 2T AC
Motore Piaggio	Motore Piaggio	Motore Piaggio	Motore Piaggio	Motore Piaggio	Motore Piaggio						
CI07494	CI07494	CI07494	CI07494	CI07494	CI07494						
IM07060				IM07060	IM07060						
IM07015	IM07073	IM07073	IM07073	IM07015	IM07015	IM07007 IM07008	IM07005 IM07007 IM07008		IM07007 IM07008		IM07007 IM07008
IM07031				IM07031	IM07031						
9924950				9924950	9924950						
	9926150										
9922040	9922040	9922040	9922040	9922040	9922040						
9935840	9935840	9935840	9935840	9935840	9935840						
CT00727	CT00737			CT00727	CT00727						
9914500				9914500	9914500						
KT00080				KT00080	KT00080	KT00010	KT00010		KT00010		KT00010
9931250 KT00086				9931250 KT00086	9931250 KT00086						
	9925150 KT00133	9928300	9928300								
KK01003 KK01009				KK01003 KK01009	KK01003 KK01009	KK01012	KK01012		KK01012		KK01012
	MC12108										
MA00002	MA00015	MA00015	MA00015	MA00002	MA00002	MA00023	MA00023	MA00023	MA00023	MA00023	MA00023
PL04058	PL04058	PL04058	PL04058	PL04058	PL04058						
	RE00018			RE00012	RE00012						
RL00040	RL00039	RL00039	RL00039	RL00040	RL00040						
	ST00004										
9910930				9910930	9910930						

SCOOTER 50cc

TOP
- performances -



PIAGGIO	PIAGGIO	PIAGGIO	PIAGGIO
VESPA PRIMAVERA 4T 2V 25KM/H	VESPA PRIMAVERA 4T 3V NOABS E4	VESPA PRIMAVERA 4T 4V	VESPA S 2T & COLLEGE
14-17	17-18	13-17	07-12
50cc 4T-2V AC	50cc 4T-3V AC	50cc 4T-4V AC	50cc 2T AC
Motore Piaggio	Motore Piaggio	Motore Piaggio	Motore Piaggio

IT	EN	FR				
ALBERO MESSA IN MOTO	KICK SHAFT	ARBRE DE DEMARREUR				CI07494
ALBERO MOTORE Con Cuscinetti e Paraoli	CRANKSHAFT with bearings and oil seals	VILEBREQUIN doté de Paliers et Joints d'huile				IM07060
ALBERO MOTORE Senza Cuscinetti e Paraoli	CRANKSHAFT without bearings and oil seals	VILEBREQUIN sans Paliers et Joints d'huile		IM07073		IM07073
BIELLA	CONROD	BIELLE				IM07031
CAMPANA FRIZIONE	CLUTCH HOUSING	CLOCHE EMBRAYAGE				9924950
CENTRALINA AD ANTICIPO FISSO	DIGITAL IGNITION UNIT	ALLUMAGE Fixe				
CENTRALINA AD ANTICIPO VARIABILE 4T	IGNITION UNIT Variable	ALLUMAGE Numérique				
CINGHIA DI TRASMISSIONE TOP	TRANSMISSION BELT TOP PERFORMANCES	COURROIE DE TRANSMISSION TOP PERFORMANCES				9922040
CINGHIA DI TRASMISSIONE Mitsubishi	TRANSMISSION BELT Mitsubishi	COURROIE DE TRANSMISSION Mitsubishi				9935480
COLLETTORE ASPIRAZIONE	INLET MANIFOLD	COLLECTEUR ASPIRATION				CT00727
FRIZIONE CENTRIFUGA Interno Ø 105	CENTRIFUGAL CLUTCH Ø 105	EMBAYAGE CENTRIFUGE Ø 105				
FRIZIONE CENTRIFUGA Interno Ø 107	CENTRIFUGAL CLUTCH Ø 107	EMBAYAGE CENTRIFUGE Ø 107				9910020
GANASCE FRENO	BRAKE SHOES	MÂCHOIRES FREIN				
GRUPPO TERMICO Ø Standard c/testa	CYLINDER KIT Ø standard with head	CYLINDRE COMPLET Ø Standard avec culasse				9914500
GRUPPO TERMICO Ø Standard s/testa	CYLINDER KIT Ø standard without head	CYLINDRE COMPLET Ø Standard sans culasse				
GRUPPO TERMICO Ø Magg. c/testa	CYLINDER KIT BIG BORE with head	CYLINDRE COMPLET Ø Majoré avec culasse				9931250 KT00086
GRUPPO TERMICO Ø Magg. s/testa	CYLINDER KIT BIG BORE without head	CYLINDRE COMPLET Ø Majoré sans culasse				9928300
GRUPPO TERMICO Modifica da AC a LC	CYLINDER KIT Conversion AC to LC	CYLINDRE COMPLET Modification de AC à LC				
KIT CUSCINETTI DA BANCO	BEARINGS KIT	KIT PALIERS DE VILEBREQUIN				KK01003 KK01009
KIT REVISIONE POMPA ACQUA	WATER PUMP REPAIR KIT	KIT RÉVISION POMPE À EAU				
MEMBRANA CARBURATORE	CARBURETOR DIAPHRAGM	MEMBRANE CARBURATEUR				
MOTORINO D'AVVIAMENTO	STARTER ENGINE	DÉMARREUR ÉLECTRIQUE				MA00002
PULEGGIA FISSA	VARIATOR SHEAVE FIXED	POULIE FIXE		PL04058		PL04058
RAPPORTI ALLUNGATI Primari	GÉARS KIT Primary	RAPPORTS ALLONGÉS Primaires				
RAPPORTI ALLUNGATI Secondari	GÉARS KIT Secondary	RAPPORTS ALLONGÉS Secondaires				
REGOLATORE DI TENSIONE	RECTIFIER	RÉGULATEUR DE TENSION				RE00012
RUOTA LIBERA	STARTER CLUTCH	ROUE LIBRE				RL00040
STATORE	STATOR	STATOR				
VALVOLE LAMELLARI	REED VALVE	CLAPET À LAMELLES				9910930

PIAGGIO	PIAGGIO	PIAGGIO	PIAGGIO	PIAGGIO	PIAGGIO	PIAGGIO	PIAGGIO	PIAGGIO	PIAGGIO	PIAGGIO	PIAGGIO
VESPA S 4T 4V & COLLEGE	VESPA SPECIAL-L-R	VESPA SPRINT 4T 2V 25KM/H	VESPA SPRINT 4T 3V E4	VESPA SPRINT 4T 4V	ZIP	ZIP	ZIP 2T	ZIP 4T	ZIP 4T	ZIP 4T 25KM/H	ZIP BIMODALE
08-12	67-82	14-17	17-20	14-17	92-93	95-96	08-13	00-05	06-13	06-16	94-97
50cc 4T-4V AC	50cc 2T AC	50cc 4T-2V AC	50cc 4T-3V AC	50cc 4T-4V AC	50cc 2T AC	50cc 2T AC	50cc 2T LC	50cc 4T AC	50cc 4T AC	50cc 4T AC	50cc 2T AC
Motore Piaggio		Motore Piaggio	Motore Piaggio	Motore Piaggio	Motore Piaggio	Motore Piaggio	Motore Piaggio	Motore Piaggio	Motore Piaggio	Motore Piaggio	Motore Piaggio
CI07494					CI07494	CI07494	CI07494	CI07494	CI07494		CI07494
					IM07060	IM07060	IM07060				IM07060
IM07073	IM07005	IM07073		IM07073	IM07015	IM07015	IM07015	IM07073	IM07073	IM07073	IM07015
					IM07031	IM07031	IM07031				IM07031
					9924950	9924950	9924950				9924950
					9924870	9924870					9924870
								9926150	9926150		
9922040					9913360	9913350	9922040	9922040	9922040		9913350
9935840				9935480		9935810	9935840	9935840	9935840		9935810
					CT00727	CT00727	CT00727	CT00738	CT00737		CT00727
			9910020		9910020	9910020		9910020	9910020		9910020
					9914500	9914500	9916580 KT00112				9914500
	KT00010				KT00080	KT00080					KT00080
					9931250 KT00086	9931250 KT00086	9931270 KT00097				9931250 KT00086
9928300		9928300	9928300					9925150 KT00133	9925150 KT00133		
	KK01011				KK01003 KK01009	KK01003 KK01009	KK01003 KK01009				KK01003 KK01009
							AA00796				
								MC12108	MC12108	MC12108	
MA00015					MA00002	MA00002	MA00002	MA00015	MA00015		MA00002
PL04058		PL04058		PL04058	PL04058	PL04058	PL04058	PL04058	PL04058	PL04058	PL04058
							RE00012	RE00018	RE00018		
RL00039					RL00040	RL00040	RL00040	RL00039	RL00039		RL00040
								ST00004	ST00004		
					9910930	9910930	9910930				9910930

SCOOTER 50cc

SCOOTER 50cc

TOP
- performances -



PIAGGIO	PIAGGIO	PIAGGIO	PIAGGIO
ZIP FAST RIDER	ZIP FAST RIDER RST	ZIP LC	ZIP RST
93-94	96-97	00-04	96-99
50cc 2T AC	50cc 2T AC	50cc 2T LC	50cc 2T AC
Motore Piaggio	Motore Piaggio	Motore Piaggio	Motore Piaggio

IT	EN	FR				
ALBERO MESSA IN MOTO	KICK SHAFT	ARBRE DE DEMARREUR		CI07494	CI07494	CI07494
ALBERO MOTORE Con Cuscinetti e Paraoli	CRANKSHAFT with bearings and oil seals	VILEBREQUIN doté de Paliers et Joints d'huile		IM07060	IM07060	IM07060
ALBERO MOTORE Senza Cuscinetti e Paraoli	CRANKSHAFT without bearings and oil seals	VILEBREQUIN sans Paliers et Joints d'huile		IM07015	IM07015	IM07015
BIELLA	CONROD	BIELLE		IM07031	IM07031	IM07031
CAMPANA FRIZIONE	CLUTCH HOUSING	CLOCHE EMBRAYAGE		9924950	9924950	9924950
CENTRALINA AD ANTICIPO FISSO	DIGITAL IGNITION UNIT	ALLUMAGE Fixe		9924870	9924870	9924870
CENTRALINA AD ANTICIPO VARIABILE 4T	IGNITION UNIT Variable	ALLUMAGE Numérique				
CINGHIA DI TRASMISSIONE TOP	TRANSMISSION BELT TOP PERFORMANCES	COURROIE DE TRANSMISSION TOP PERFORMANCES		9913350	9913350	9922040
CINGHIA DI TRASMISSIONE Mitsubishi	TRANSMISSION BELT Mitsubishi	COURROIE DE TRANSMISSION Mitsubishi		9935810	9935810	9935840
COLLETTORE ASPIRAZIONE	INLET MANIFOLD	COLLECTEUR ASPIRATION		CT00727	CT00727	CT00727
FRIZIONE CENTRIFUGA Interno Ø 105	CENTRIFUGAL CLUTCH Ø 105	EMBAYAGE CENTRIFUGE Ø 105				
FRIZIONE CENTRIFUGA Interno Ø 107	CENTRIFUGAL CLUTCH Ø 107	EMBAYAGE CENTRIFUGE Ø 107		9910020	9910020	9910020
GANASCE FRENO	BRAKE SHOES	MÂCHOIRES FREIN				
GRUPPO TERMICO Ø Standard c/testa	CYLINDER KIT Ø standard with head	CYLINDRE COMPLET Ø Standard avec culasse		9914500	9914500	9916580 KT00112
GRUPPO TERMICO Ø Standard s/testa	CYLINDER KIT Ø standard without head	CYLINDRE COMPLET Ø Standard sans culasse		KT00080	KT00080	KT00080
GRUPPO TERMICO Ø Magg. c/testa	CYLINDER KIT BIG BORE with head	CYLINDRE COMPLET Ø Majoré avec culasse		9931250 KT00086	9931250 KT00086	9931270 KT00097
GRUPPO TERMICO Ø Magg. s/testa	CYLINDER KIT BIG BORE without head	CYLINDRE COMPLET Ø Majoré sans culasse				
GRUPPO TERMICO Modifica da AC a LC	CYLINDER KIT Conversion AC to LC	CYLINDRE COMPLET Modification de AC à LC				
KIT CUSCINETTI DA BANCO	BEARINGS KIT	KIT PALIERS DE VILEBREQUIN		KK01003 KK01009	KK01003 KK01009	KK01003 KK01009
KIT REVISIONE POMPA ACQUA	WATER PUMP REPAIR KIT	KIT RÉVISION POMPE À EAU				AA00796
MEMBRANA CARBURATORE	CARBURETOR DIAPHRAGM	MEMBRANE CARBURATEUR				
MOTORINO D'AVVIAMENTO	STARTER ENGINE	DÉMARREUR ÉLECTRIQUE		MA00002	MA00002	MA00002
PULEGGIA FISSA	VARIATOR SHEAVE FIXED	POULIE FIXE		PL04058	PL04058	PL04058
RAPPORTI ALLUNGATI Primari	GÉARS KIT Primary	RAPPORTS ALLONGÉS Primaires				
RAPPORTI ALLUNGATI Secondari	GÉARS KIT Secondary	RAPPORTS ALLONGÉS Secondaires				
REGOLATORE DI TENSIONE	RECTIFIER	RÉGULATEUR DE TENSION				RE00012
RUOTA LIBERA	STARTER CLUTCH	ROUE LIBRE		RL00040	RL00040	RL00040
STATORE	STATOR	STATOR				
VALVOLE LAMELLARI	REED VALVE	CLAPET À LAMELLES		9910930	9910930	9910930

PIAGGIO	PIAGGIO	PIAGGIO	PIAGGIO	PIAGGIO	RIEJU	RIEJU	RIEJU	RIEJU	RIEJU	SUZUKI	SUZUKI
ZIP SP	ZIP SP	ZIP SP	ZIP SP	ZIP SP EURO 2	FIRST	PACIFIC	PASEO	TOREO	WINDY	AH ADDRESS	AJ ZZ
96-00	96-00	01-04	01-04	06-13	95-98	07-08	07-08	07-08	95-98	92-95	95-97
50cc 2T	50cc 2T LC	50cc 2T	50cc 2T LC	50cc 2T LC	50cc 2T AC	50cc 4T AC	50cc 4T AC	50cc 4T AC	50cc 2T AC	50cc 2T AC	50cc 2T AC
Motore Piaggio	Motore Piaggio	Motore Piaggio	Motore Piaggio	Motore Piaggio	MY	Tipo Kymco	Tipo Kymco	Tipo Kymco	MY	Motore Suzuki	Motore Suzuki
	CI07494		CI07494	CI07494	CI07487				CI07487		
	IM07060		IM07060	IM07060	IM07059				IM07059		
	IM07015		IM07015	IM07015	IM07014				IM07014		
	IM07031		IM07031	IM07031	IM07032				IM07032		
	9924950		9924950	9924950	9924940				9924940		
	9924870										
	9913350		9922040	9922040	9907770				9907770		
	9935810		9935840	9935840	9935270				9935270		
	CT00727		CT00727	CT00727	CT00725				CT00725		
					9911060				9911060		
	9910020				9910020 9925130				9910020 9925130		
CP00240		CP00240									
	9916580 KT00112		9916580 KT00112	9916580 KT00112	9931140 KT00095				9931140 KT00095		
	9931270 KT00097		9931270 KT00097	9931270 KT00097	9931340 KT00087				9931340 KT00087		
						9925140 KT00132	9925140 KT00132	9925140 KT00132		KT00057	KT00057
					9911090				9911090		
	KK01003 KK01009		KK01003 KK01009	KK01003 KK01009	KK01000 KK01002				KK01000 KK01002		
	AA00796		AA00796	AA00796							
	MA00002		MA00002	MA00002	MA00001				MA00001		
	PL04058		PL04058	PL04058	PL04055 PL04056				PL04055 PL04056		
					9913300				9913300		
			RE00012	RE00012							
	RL00040		RL00040	RL00040	AA00767 RL00001				AA00767 RL00001		
	9910930		9910930	9910930	9908370				9908370		

SCOOTER 50cc

TOP
- performances -



SUZUKI	SUZUKI	SUZUKI	SUZUKI
AP	ESTILETE UF	KATANA K1-K4	KATANA V-Y
94-97	00-00	01-04	97-00
50cc 2T AC	50cc 2T AC	50cc 2T LC	50cc 2T AC
Motore Suzuki	Motore Suzuki	Motore Suzuki	Motore Suzuki

IT	EN	FR				
ALBERO MESSA IN MOTO	KICK SHAFT	ARBRE DE DEMARREUR				
ALBERO MOTORE Con Cuscinetti e Paraoli	CRANKSHAFT with bearings and oil seals	VILEBREQUIN doté de Paliers et Joints d'huile				
ALBERO MOTORE Senza Cuscinetti e Paraoli	CRANKSHAFT without bearings and oil seals	VILEBREQUIN sans Paliers et Joints d'huile				
BIELLA	CONROD	BIELLE				
CAMPANA FRIZIONE	CLUTCH HOUSING	CLOCHE EMBRAYAGE				
CENTRALINA AD ANTICIPO FISSO	DIGITAL IGNITION UNIT	ALLUMAGE Fixe				
CENTRALINA AD ANTICIPO VARIABILE 4T	IGNITION UNIT Variable	ALLUMAGE Numérique				
CINGHIA DI TRASMISSIONE TOP	TRANSMISSION BELT TOP PERFORMANCES	COURROIE DE TRANSMISSION TOP PERFORMANCES			9920440	9920440
CINGHIA DI TRASMISSIONE Mitsubishi	TRANSMISSION BELT Mitsubishi	COURROIE DE TRANSMISSION Mitsubishi		9935950	9935820	9935820 9935950
COLLETTORE ASPIRAZIONE	INLET MANIFOLD	COLLECTEUR ASPIRATION				
FRIZIONE CENTRIFUGA Interno Ø 105	CENTRIFUGAL CLUTCH Ø 105	EMBAYAGE CENTRIFUGE Ø 105				
FRIZIONE CENTRIFUGA Interno Ø 107	CENTRIFUGAL CLUTCH Ø 107	EMBAYAGE CENTRIFUGE Ø 107				
GANASCE FRENO	BRAKE SHOES	MÂCHOIRES FREIN				
GRUPPO TERMICO Ø Standard c/testa	CYLINDER KIT Ø standard with head	CYLINDRE COMPLET Ø Standard avec culasse				
GRUPPO TERMICO Ø Standard s/testa	CYLINDER KIT Ø standard without head	CYLINDRE COMPLET Ø Standard sans culasse				
GRUPPO TERMICO Ø Magg. c/testa	CYLINDER KIT BIG BORE with head	CYLINDRE COMPLET Ø Majoré avec culasse				
GRUPPO TERMICO Ø Magg. s/testa	CYLINDER KIT BIG BORE without head	CYLINDRE COMPLET Ø Majoré sans culasse		KT00057		
GRUPPO TERMICO Modifica da AC a LC	CYLINDER KIT Conversion AC to LC	CYLINDRE COMPLET Modification de AC à LC				
KIT CUSCINETTI DA BANCO	BEARINGS KIT	KIT PALIERS DE VILEBREQUIN				
KIT REVISIONE POMPA ACQUA	WATER PUMP REPAIR KIT	KIT RÉVISION POMPE À EAU			AA00808 AA00809	
MEMBRANA CARBURATORE	CARBURETOR DIAPHRAGM	MEMBRANE CARBURATEUR				
MOTORINO D'AVVIAMENTO	STARTER ENGINE	DÉMARREUR ÉLECTRIQUE				
PULEGGIA FISSA	VARIATOR SHEAVE FIXED	POULIE FIXE				
RAPPORTI ALLUNGATI Primari	GÉARS KIT Primary	RAPPORTS ALLONGÉS Primaires				
RAPPORTI ALLUNGATI Secondari	GÉARS KIT Secondary	RAPPORTS ALLONGÉS Secondaires				
REGOLATORE DI TENSIONE	RECTIFIER	RÉGULATEUR DE TENSION				
RUOTA LIBERA	STARTER CLUTCH	ROUE LIBRE				
STATORE	STATOR	STATOR				
VALVOLE LAMELLARI	REED VALVE	CLAPET À LAMELLES				

SUZUKI	SUZUKI	SUZUKI	SYM	SYM	SYM	SYM	SYM	SYM	SYM	SYM	SYM
KATANA V-Y	STREET MAGIC	ZILLION UX	DD	JET	JUNGLE	MASK	MASK	MASK EU2	MIO	RED DEVIL	SUPER FANCY
97-00	98-98	99-99	02-02	99-01	99-00	00-01	00-01	03-04	06-09	99-99	98-00
50cc 2T LC	50cc 2T AC	50cc 2T LC	50cc 2T AC	50cc 2T AC	50cc 2T AC	50cc 2T	50cc 2T AC	50cc 2T AC	50cc 4T AC	50cc 2T AC	50cc 2T AC
Motore Suzuki	Motore Suzuki	Motore Suzuki									
9920440		9920440									
9935820 9935950		9935820									
						CP00219					
	KT00057										
AA00808		AA00809									
				MA00014	MA00014		MA00014	MA00014	MA00024	MA00014	MA00014
				RE00013	RE00013		RE00013			RE00013	RE00013
			9912550								

SCOOTER 50cc

SCOOTER 50cc

TOP
- performances -



SYM	SYM	SYM	SYM
SYMPHONY EURO 2	SYMPHONY S	SYMPHONY SR	SYMPLY EURO 2
09-09	10-10	10-10	07-08
50cc 4T AC	50cc 4T AC	50cc 4T AC	50cc 4T AC
			Tipo Kymco

IT	EN	FR				
ALBERO MESSA IN MOTO	KICK SHAFT	ARBRE DE DEMARREUR				
ALBERO MOTORE Con Cuscinetti e Paraoli	CRANKSHAFT with bearings and oil seals	VILEBREQUIN doté de Paliers et Joints d'huile				
ALBERO MOTORE Senza Cuscinetti e Paraoli	CRANKSHAFT without bearings and oil seals	VILEBREQUIN sans Paliers et Joints d'huile				
BIELLA	CONROD	BIELLE				
CAMPANA FRIZIONE	CLUTCH HOUSING	CLOCHE EMBRAYAGE				
CENTRALINA AD ANTICIPO FISSO	DIGITAL IGNITION UNIT	ALLUMAGE Fixe				
CENTRALINA AD ANTICIPO VARIABILE 4T	IGNITION UNIT Variable	ALLUMAGE Numérique				
CINGHIA DI TRASMISSIONE TOP	TRANSMISSION BELT TOP PERFORMANCES	COURROIE DE TRANSMISSION TOP PERFORMANCES		9920440		
CINGHIA DI TRASMISSIONE Mitsubishi	TRANSMISSION BELT Mitsubishi	COURROIE DE TRANSMISSION Mitsubishi		9935820		
COLLETTORE ASPIRAZIONE	INLET MANIFOLD	COLLECTEUR ASPIRATION				
FRIZIONE CENTRIFUGA Interno Ø 105	CENTRIFUGAL CLUTCH Ø 105	EMBAYAGE CENTRIFUGE Ø 105				
FRIZIONE CENTRIFUGA Interno Ø 107	CENTRIFUGAL CLUTCH Ø 107	EMBAYAGE CENTRIFUGE Ø 107				
GANASCE FRENO	BRAKE SHOES	MÂCHOIRES FREIN				
GRUPPO TERMICO Ø Standard c/testa	CYLINDER KIT Ø standard with head	CYLINDRE COMPLET Ø Standard avec culasse				
GRUPPO TERMICO Ø Standard s/testa	CYLINDER KIT Ø standard without head	CYLINDRE COMPLET Ø Standard sans culasse				
GRUPPO TERMICO Ø Magg. c/testa	CYLINDER KIT BIG BORE with head	CYLINDRE COMPLET Ø Majoré avec culasse				
GRUPPO TERMICO Ø Magg. s/testa	CYLINDER KIT BIG BORE without head	CYLINDRE COMPLET Ø Majoré sans culasse				9925140 KT00132
GRUPPO TERMICO Modifica da AC a LC	CYLINDER KIT Conversion AC to LC	CYLINDRE COMPLET Modification de AC à LC				
KIT CUSCINETTI DA BANCO	BEARINGS KIT	KIT PALIERS DE VILEBREQUIN				
KIT REVISIONE POMPA ACQUA	WATER PUMP REPAIR KIT	KIT RÉVISION POMPE À EAU				
MEMBRANA CARBURATORE	CARBURETOR DIAPHRAGM	MEMBRANE CARBURATEUR				
MOTORINO D'AVVIAMENTO	STARTER ENGINE	DÉMARREUR ÉLECTRIQUE		MA00024	MA00024	MA00024
PULEGGIA FISSA	VARIATOR SHEAVE FIXED	POULIE FIXE				
RAPPORTI ALLUNGATI Primari	GÉARS KIT Primary	RAPPORTS ALLONGÉS Primaires				
RAPPORTI ALLUNGATI Secondari	GÉARS KIT Secondary	RAPPORTS ALLONGÉS Secondaires				
REGOLATORE DI TENSIONE	RECTIFIER	RÉGULATEUR DE TENSION				
RUOTA LIBERA	STARTER CLUTCH	ROUE LIBRE				
STATORE	STATOR	STATOR				
VALVOLE LAMELLARI	REED VALVE	CLAPET À LAMELLES				

WT MOTORS	YAMAHA	YAMAHA	YAMAHA	YAMAHA	YAMAHA	YAMAHA	YAMAHA	YAMAHA	YAMAHA	YAMAHA	YAMAHA
BILBAO	AEROX	AEROX	AEROX	AEROX	AEROX	AEROX	AEROX	AEROX	AEROX	AEROX	AEROX EURO 2
11-15	97-12	01-02	04-04	05-05	06-06	07-07	08-08	09-09	10-12	13-16	03-03
50cc 4T AC	50cc 2T LC	50cc 2T LC	50cc 2T LC	50cc 2T LC	50cc 2T LC	50cc 2T LC	50cc 2T LC	50cc 2T LC	50cc 2T LC	50cc 2T LC	50cc 2T LC
Tipo Kymco	MA	MA	MA	MA	MA	MA	MA	MA	MA	MA	MA
	CI07487	CI07487	CI07487	CI07487	CI07487	CI07487	CI07487	CI07487	CI07487	CI07487	CI07487
	IM07059	IM07059	IM07059	IM07059	IM07059	IM07059	IM07059	IM07059	IM07059	IM07059	IM07059
	IM07014	IM07014	IM07014	IM07014	IM07014	IM07014	IM07014	IM07014	IM07014	IM07014	IM07014
	IM07032	IM07032	IM07032	IM07032	IM07032	IM07032	IM07032	IM07032	IM07032	IM07032	IM07032
	9924940	9924940	9924940	9924940	9924940	9924940	9924940	9924940	9924940	9924940	9924940
	9910100	9910100	9910100	9910100	9910100	9910100	9910100	9910100	9910100	9910100	9910100
	9907770	9907770	9907770	9907770	9907770	9907770	9907770	9907770	9907770	9907770	9907770
	9935270	9935270	9935270	9935270	9935270	9935270	9935270	9935270	9935270	9935270	9935270
	CT00725	CT00725	CT00725	CT00725	CT00725	CT00725	CT00725	CT00725	CT00725	CT00725	CT00725
	9911060	9911060	9911060	9911060	9911060	9911060	9911060	9911060	9911060	9911060	9911060
	9910020 9925130	9910020 9925130	9910020 9925130	9910020 9925130	9910020 9925130	9910020 9925130	9910020 9925130	9910020 9925130	9910020 9925130	9910020 9925130	9910020 9925130
	9931110	9931110	9931110	9931110	9931110	9931110	9931110	9931110	9931110	9931110	9931110
	KT00094	KT00094	KT00094	KT00094	KT00094	KT00094	KT00094	KT00094	KT00094	KT00094	KT00094
	9931310 KT00109	9931310 KT00109	9931310 KT00109	9931310 KT00109	9931310 KT00109	9931310 KT00109	9931310 KT00109	9931310 KT00109	9931310 KT00109	9931310 KT00109	9931310 KT00109
9925140 KT00132											
	KK01000 KK01002	KK01000 KK01002	KK01000 KK01002	KK01000 KK01002	KK01000 KK01002	KK01000 KK01002	KK01000 KK01002	KK01000 KK01002	KK01000 KK01002	KK01000 KK01002	KK01000 KK01002
	AA00788	AA00788	AA00788	AA00788	AA00788	AA00788	AA00788	AA00788	AA00788	AA00788	AA00788
	MA00001	MA00001	MA00001	MA00001	MA00001	MA00001	MA00001	MA00001	MA00001	MA00001	MA00001
	PL04055 PL04056	PL04055 PL04056	PL04055 PL04056	PL04055 PL04056	PL04055 PL04056	PL04055 PL04056	PL04055 PL04056	PL04055 PL04056	PL04055 PL04056	PL04055 PL04056	PL04055 PL04056
	9913300	9913300	9913300	9913300	9913300	9913300	9913300	9913300	9913300	9913300	9913300
	9909520	9909520	9909520	9909520	9909520	9909520	9909520	9909520	9909520	9909520	9909520
	RE00014	RE00014	RE00014	RE00014	RE00014	RE00014	RE00014	RE00014	RE00014	RE00014	RE00015
	AA00767 RL00001	AA00767 RL00001	AA00767 RL00001	AA00767 RL00001	AA00767 RL00001	AA00767 RL00001	AA00767 RL00001	AA00767 RL00001	AA00767 RL00001	AA00767 RL00001	AA00767 RL00001
	9908370	9908370	9908370	9908370	9908370	9908370	9908370	9908370	9908370	9908370	9908370

SCOOTER 50cc

TOP
- performances -



YAMAHA	YAMAHA	YAMAHA	YAMAHA
AEROX NAKED	AEROX R	AEROX R	AXIS
13-16	99-99	99-00	95-96
50cc 2T LC	50cc 2T LC	50cc 2T LC	50cc 2T AC
MA	MA	MA	CY

IT	EN	FR				
ALBERO MESSA IN MOTO	KICK SHAFT	ARBRE DE DEMARREUR		CI07487	CI07487	CI07487
ALBERO MOTORE Con Cuscinetti e Paraoli	CRANKSHAFT with bearings and oil seals	VILEBREQUIN doté de Paliers et Joints d'huile		IM07059	IM07059	IM07059
ALBERO MOTORE Senza Cuscinetti e Paraoli	CRANKSHAFT without bearings and oil seals	VILEBREQUIN sans Paliers et Joints d'huile		IM07014	IM07014	IM07014
BIELLA	CONROD	BIELLE		IM07032	IM07032	IM07032
CAMPANA FRIZIONE	CLUTCH HOUSING	CLOCHE EMBRAYAGE		9924940	9924940	9924940
CENTRALINA AD ANTICIPO FISSO	DIGITAL IGNITION UNIT	ALLUMAGE Fixe		9910100	9910100	9910100
CENTRALINA AD ANTICIPO VARIABILE 4T	IGNITION UNIT Variable	ALLUMAGE Numérique				
CINGHIA DI TRASMISSIONE TOP	TRANSMISSION BELT TOP PERFORMANCES	COURROIE DE TRANSMISSION TOP PERFORMANCES		9907770	9907770	9907770
CINGHIA DI TRASMISSIONE Mitsubishi	TRANSMISSION BELT Mitsubishi	COURROIE DE TRANSMISSION Mitsubishi		9935270	9935270	9935270
COLLETTORE ASPIRAZIONE	INLET MANIFOLD	COLLECTEUR ASPIRATION		CT00725	CT00725	CT00725
FRIZIONE CENTRIFUGA Interno Ø 105	CENTRIFUGAL CLUTCH Ø 105	EMBAYAGE CENTRIFUGE Ø 105		9911060	9911060	9911060
FRIZIONE CENTRIFUGA Interno Ø 107	CENTRIFUGAL CLUTCH Ø 107	EMBAYAGE CENTRIFUGE Ø 107		9910020 9925130	9910020 9925130	9910020 9925130
GANASCE FRENO	BRAKE SHOES	MÂCHOIRES FREIN				
GRUPPO TERMICO Ø Standard c/testa	CYLINDER KIT Ø standard with head	CYLINDRE COMPLET Ø Standard avec culasse		9931110	9931110	9931110
GRUPPO TERMICO Ø Standard s/testa	CYLINDER KIT Ø standard without head	CYLINDRE COMPLET Ø Standard sans culasse		KT00094	KT00094	KT00094
GRUPPO TERMICO Ø Magg. c/testa	CYLINDER KIT BIG BORE with head	CYLINDRE COMPLET Ø Majoré avec culasse		9931310 KT00109	9931310 KT00109	9931310 KT00109
GRUPPO TERMICO Ø Magg. s/testa	CYLINDER KIT BIG BORE without head	CYLINDRE COMPLET Ø Majoré sans culasse				
GRUPPO TERMICO Modifica da AC a LC	CYLINDER KIT Conversion AC to LC	CYLINDRE COMPLET Modification de AC à LC				9911090
KIT CUSCINETTI DA BANCO	BEARINGS KIT	KIT PALIERS DE VILEBREQUIN		KK01000 KK01002	KK01000 KK01002	KK01000 KK01002
KIT REVISIONE POMPA ACQUA	WATER PUMP REPAIR KIT	KIT RÉVISION POMPE À EAU		AA00788	AA00788	AA00788
MEMBRANA CARBURATORE	CARBURETOR DIAPHRAGM	MEMBRANE CARBURATEUR				
MOTORINO D'AVVIAMENTO	STARTER ENGINE	DÉMARREUR ÉLECTRIQUE		MA00001	MA00001	MA00001
PULEGGIA FISSA	VARIATOR SHEAVE FIXED	POULIE FIXE		PL04055 PL04056	PL04055 PL04056	PL04055 PL04056
RAPPORTI ALLUNGATI Primari	GÉARS KIT Primary	RAPPORTS ALLONGÉS Primaires		9913300	9913300	9913300
RAPPORTI ALLUNGATI Secondari	GÉARS KIT Secondary	RAPPORTS ALLONGÉS Secondaires		9909520	9909520	9909520
REGOLATORE DI TENSIONE	RECTIFIER	RÉGULATEUR DE TENSION		RE00014	RE00014	RE00014
RUOTA LIBERA	STARTER CLUTCH	ROUE LIBRE		AA00767 RL00001	AA00767 RL00001	AA00767 RL00001
STATORE	STATOR	STATOR				
VALVOLE LAMELLARI	REED VALVE	CLAPET À LAMELLES		9908370	9908370	9908370

YAMAHA	YAMAHA	YAMAHA	YAMAHA	YAMAHA	YAMAHA	YAMAHA	YAMAHA	YAMAHA	YAMAHA	YAMAHA	YAMAHA
BREEZE	BW'S	BW'S	BW'S	BW'S	BW'S	BW'S BUMP	BW'S EASY	BW'S NAKED	BW'S NAKED	BW'S NAKED	BW'S NAKED
94-95	97-04	04-05	06-07	08-12	13-16	97-98	13-13	03-03	04-04	09-12	13-16
50cc 2T AC	50cc 2T AC	50cc 2T AC	50cc 2T AC	50cc 2T AC	50cc 2T AC	50cc 2T AC	50cc 2T AC	50cc 2T AC	50cc 2T AC	50cc 2T AC	50cc 2T AC
CY	CW	CW	CW	CW	CW	CW	CW	CW	CW	CW	CW
	CI07487	CI07487	CI07487	CI07487	CI07487	CI07487	CI07487	CI07487	CI07487	CI07487	CI07487
IM07059	IM07058	IM07058	IM07058	IM07058	IM07058	IM07058	IM07058	IM07058	IM07058	IM07058	IM07058
IM07014	IM07013	IM07013	IM07013	IM07013	IM07013	IM07013	IM07013	IM07013	IM07013	IM07013	IM07013
IM07032	IM07032	IM07032	IM07032	IM07032	IM07032	IM07032	IM07032	IM07032	IM07032	IM07032	IM07032
9924940											
9910100	9910100					9910100		9910100			
9907900	9907770	9907770	9907770	9907770	9907770	9907770	9907770	9907770	9907770	9907770	9907770
9935340	9935270	9935270	9935270	9935270	9935270	9935270	9935270	9935270	9935270	9935270	9935270
CT00725	CT00726	CT00726	CT00726	CT00726	CT00726	CT00726	CT00726	CT00726	CT00726	CT00726	CT00726
	9911060	9911060	9911060	9911060	9911060	9911060	9911060	9911060	9911060	9911060	9911060
9925130	9910020 9925130	9910020 9925130	9910020 9925130	9910020 9925130	9910020 9925130	9910020 9925130	9910020 9925130	9910020 9925130	9910020 9925130	9910020 9925130	9910020 9925130
9931140	9931170	9931170	9931170	9931170	9931170	9931170	9931170	9931170	9931170	9931170	9931170
KT00095	KT00096	KT00096	KT00096	KT00096	KT00096	KT00096	KT00096	KT00096	KT00096	KT00096	KT00096
9931340 KT00087	9931370 KT00088	9931370 KT00088	9931370 KT00088	9931370 KT00088	9931370 KT00088	9931370 KT00088	9931370 KT00088	9931370 KT00088	9931370 KT00088	9931370 KT00088	9931370 KT00088
9911090											
KK01000 KK01002	KK01000 KK01002	KK01000 KK01002	KK01000 KK01002	KK01000 KK01002	KK01000 KK01002	KK01000 KK01002	KK01000 KK01002	KK01000 KK01002	KK01000 KK01002	KK01000 KK01002	KK01000 KK01002
MA00001	MA00001	MA00001	MA00001	MA00001	MA00001	MA00001	MA00001	MA00001	MA00001	MA00001	MA00001
PL04055 PL04056	PL04055 PL04056	PL04055 PL04056	PL04055 PL04056	PL04055 PL04056	PL04055 PL04056	PL04055 PL04056	PL04055 PL04056	PL04055 PL04056	PL04055 PL04056	PL04055 PL04056	PL04055 PL04056
	9913300	9913300	9913300	9913300	9913300	9913300	9913300	9913300	9913300	9913300	9913300
RE00014	RE00014	RE00015	RE00015	RE00015	RE00015	RE00014	RE00015	RE00014	RE00015	RE00015	RE00015
AA00767 RL00001	AA00767 RL00001	AA00767 RL00001	AA00767 RL00001	AA00767 RL00001	AA00767 RL00001	AA00767 RL00001	AA00767 RL00001	AA00767 RL00001	AA00767 RL00001	AA00767 RL00001	AA00767 RL00001
9908370	9906520	9906520	9906520	9906520	9906520	9906520	9906520	9906520	9906520	9906520	9906520

SCOOTER 50cc

TOP
- performances -



YAMAHA	YAMAHA	YAMAHA	YAMAHA
BW'S NEXT GENERATION	BW'S NEXT GENERATION	BW'S NEXT GENERATION	BW'S NEXT GENERATION
97-98	99-99	99-00	01-02
50cc 2T AC	50cc 2T AC	50cc 2T AC	50cc 2T AC
CW	CW	CW	CW

IT	EN	FR					
ALBERO MESSA IN MOTO	KICK SHAFT	ARBRE DE DEMARREUR		CI07487	CI07487	CI07487	CI07487
ALBERO MOTORE Con Cuscinetti e Paraoli	CRANKSHAFT with bearings and oil seals	VILEBREQUIN doté de Paliers et Joints d'huile		IM07058	IM07058	IM07058	IM07058
ALBERO MOTORE Senza Cuscinetti e Paraoli	CRANKSHAFT without bearings and oil seals	VILEBREQUIN sans Paliers et Joints d'huile		IM07013	IM07013	IM07013	IM07013
BIELLA	CONROD	BIELLE		IM07032	IM07032	IM07032	IM07032
CAMPANA FRIZIONE	CLUTCH HOUSING	CLOCHE EMBRAYAGE					
CENTRALINA AD ANTICIPO FISSO	DIGITAL IGNITION UNIT	ALLUMAGE Fixe		9910100	9910100	9910100	9910100
CENTRALINA AD ANTICIPO VARIABILE 4T	IGNITION UNIT Variable	ALLUMAGE Numérique					
CINGHIA DI TRASMISSIONE TOP	TRANSMISSION BELT TOP PERFORMANCES	COURROIE DE TRANSMISSION TOP PERFORMANCES		9907770	9907770	9907770	9907770
CINGHIA DI TRASMISSIONE Mitsubishi	TRANSMISSION BELT Mitsubishi	COURROIE DE TRANSMISSION Mitsubishi		9935270	9935270	9935270	9935270
COLLETTORE ASPIRAZIONE	INLET MANIFOLD	COLLECTEUR ASPIRATION		CT00726	CT00726	CT00726	CT00726
FRIZIONE CENTRIFUGA Interno Ø 105	CENTRIFUGAL CLUTCH Ø 105	EMBAYAGE CENTRIFUGE Ø 105		9911060	9911060	9911060	9911060
FRIZIONE CENTRIFUGA Interno Ø 107	CENTRIFUGAL CLUTCH Ø 107	EMBAYAGE CENTRIFUGE Ø 107		9910020 9925130	9910020 9925130	9910020 9925130	9910020 9925130
GANASCE FRENO	BRAKE SHOES	MÂCHOIRES FREIN					
GRUPPO TERMICO Ø Standard c/testa	CYLINDER KIT Ø standard with head	CYLINDRE COMPLET Ø Standard avec culasse		9931170	9931170	9931170	9931170
GRUPPO TERMICO Ø Standard s/testa	CYLINDER KIT Ø standard without head	CYLINDRE COMPLET Ø Standard sans culasse		KT00096	KT00096	KT00096	KT00096
GRUPPO TERMICO Ø Magg. c/testa	CYLINDER KIT BIG BORE with head	CYLINDRE COMPLET Ø Majoré avec culasse		9931370 KT00088	9931370 KT00088	9931370 KT00088	9931370 KT00088
GRUPPO TERMICO Ø Magg. s/testa	CYLINDER KIT BIG BORE without head	CYLINDRE COMPLET Ø Majoré sans culasse					
GRUPPO TERMICO Modifica da AC a LC	CYLINDER KIT Conversion AC to LC	CYLINDRE COMPLET Modification de AC à LC					
KIT CUSCINETTI DA BANCO	BEARINGS KIT	KIT PALIERS DE VILEBREQUIN		KK01000 KK01002	KK01000 KK01002	KK01000 KK01002	KK01000 KK01002
KIT REVISIONE POMPA ACQUA	WATER PUMP REPAIR KIT	KIT RÉVISION POMPE À EAU					
MEMBRANA CARBURATORE	CARBURETOR DIAPHRAGM	MEMBRANE CARBURATEUR					
MOTORINO D'AVVIAMENTO	STARTER ENGINE	DÉMARREUR ÉLECTRIQUE		MA00001	MA00001	MA00001	MA00001
PULEGGIA FISSA	VARIATOR SHEAVE FIXED	POULIE FIXE		PL04055 PL04056	PL04055 PL04056	PL04055 PL04056	PL04055 PL04056
RAPPORTI ALLUNGATI Primari	GÉARS KIT Primary	RAPPORTS ALLONGÉS Primaires		9913300	9913300	9913300	9913300
RAPPORTI ALLUNGATI Secondari	GÉARS KIT Secondary	RAPPORTS ALLONGÉS Secondaires		9909520			
REGOLATORE DI TENSIONE	RECTIFIER	RÉGULATEUR DE TENSION		RE00014	RE00014	RE00014	RE00014
RUOTA LIBERA	STARTER CLUTCH	ROUE LIBRE		AA00767 RL00001	AA00767 RL00001	AA00767 RL00001	AA00767 RL00001
STATORE	STATOR	STATOR					
VALVOLE LAMELLARI	REED VALVE	CLAPET À LAMELLES		9906520	9906520	9906520	9906520

YAMAHA	YAMAHA	YAMAHA	YAMAHA	YAMAHA	YAMAHA	YAMAHA	YAMAHA	YAMAHA	YAMAHA	YAMAHA	YAMAHA
BW'S NEXT GENERATION	BW'S NEXT GENERATION	BW'S ORIGINAL	BW'S ORIGINAL	BW'S ORIGINAL	BW'S ORIGINAL	BW'S ORIGINAL EURO 2	CRZ	CRZ	CT	GIGGLE	JOG
03-03	04-06	99-99	99-00	01-01	01-02	03-03	91-95	91-95	90-95	08-08	92-01
50cc 2T AC	50cc 2T AC	50cc 2T AC	50cc 2T AC	50cc 2T AC	50cc 2T AC	50cc 2T AC	50cc 2T	50cc 2T AC	50cc 2T AC	50cc 4T-3V LC	50cc 2T AC
CW	CW	CW	CW	CW	CW	CW	Tipo CW	Tipo CW	Tipo CW	15P1	Tipo CY
CI07487	CI07487	CI07487	CI07487	CI07487	CI07487	CI07487					
IM07058	IM07058	IM07058	IM07058	IM07058	IM07058	IM07058					IM07059
IM07013	IM07013	IM07013	IM07013	IM07013	IM07013	IM07013					IM07014
IM07032	IM07032	IM07032	IM07032	IM07032	IM07032	IM07032					IM07032
											9924940
		9910100	9910100	9910100	9910100						9910100
9907770	9907770	9907770	9907770	9907770	9907770	9907770		9907900			9907900
9935270	9935270	9935270	9935270	9935270	9935270	9935270		9935340		9935590	9935340
CT00726	CT00726	CT00726	CT00726	CT00726	CT00726	CT00726					CT00725
9911060	9911060	9911060	9911060	9911060	9911060	9911060		9911060	9911060		
9910020 9925130	9910020 9925130	9910020 9925130	9910020 9925130	9910020 9925130	9910020 9925130	9910020 9925130		9910020 9925130	9910020 9925130	9925130	9925130
							CP00239				
9931170	9931170	9931170	9931170	9931170	9931170	9931170					9931140
KT00096	KT00096	KT00096	KT00096	KT00096	KT00096	KT00096					KT00095
9931370 KT00088	9931370 KT00088	9931370 KT00088	9931370 KT00088	9931370 KT00088	9931370 KT00088	9931370 KT00088					9931340 KT00087
										9926330	
											9911090
KK01000 KK01002	KK01000 KK01002	KK01000 KK01002	KK01000 KK01002	KK01000 KK01002	KK01000 KK01002	KK01000 KK01002					KK01000 KK01002
MA00001	MA00001	MA00001	MA00001	MA00001	MA00001	MA00001					
PL04055 PL04056	PL04055 PL04056	PL04055 PL04056	PL04055 PL04056	PL04055 PL04056	PL04055 PL04056	PL04055 PL04056					
9913300	9913300	9913300	9913300	9913300	9913300	9913300					
9909520											
RE00015	RE00015	RE00014	RE00014	RE00014	RE00014	RE00015					
AA00767 RL00001	AA00767 RL00001	AA00767 RL00001	AA00767 RL00001	AA00767 RL00001	AA00767 RL00001	AA00767 RL00001		AA00767			AA00767 RL00001
9906520	9906520	9906520	9906520	9906520	9906520	9906520					9908370

SCOOTER 50cc

SCOOTER 50cc

TOP
- performances -



YAMAHA	YAMAHA	YAMAHA	YAMAHA
JOG ER	JOG R	JOG R EURO2	JOG R EURO2
00-02	02-02	02-02	06-12
50cc 2T AC	50cc 2T AC	50cc 2T AC	50cc 2T AC
Tipo CY	MY	MY	MY
	CI07487	CI07487	CI07487
	IM07059	IM07059	IM07059
	IM07014	IM07014	IM07014
	IM07032	IM07032	IM07032
	9924940	9924940	9924940
	9910100		
	9907770	9907770	9907770
	9935270	9935270	9935270
	CT00725	CT00725	CT00725
	9911060	9911060	9911060
	9925130	9910020 9925130	9910020 9925130
	9931140	9931140	9931140
	KT00095	KT00095	KT00095
	KT00087	9931340 KT00087	9931340 KT00087
	9911090	9911090	9911090
	KK01000 KK01002	KK01000 KK01002	KK01000 KK01002
	MA00001	MA00001	MA00001
	PL04055 PL04056	PL04055 PL04056	PL04055 PL04056
	9913300	9913300	9913300
	RE00015	RE00015	RE00015
	AA00767 RL00001	AA00767 RL00001	AA00767 RL00001
	9908370	9908370	9908370

IT	EN	FR
ALBERO MESSA IN MOTO	KICK SHAFT	ARBRE DE DEMARREUR
ALBERO MOTORE Con Cuscinetti e Paraoli	CRANKSHAFT with bearings and oil seals	VILEBREQUIN doté de Paliers et Joints d'huile
ALBERO MOTORE Senza Cuscinetti e Paraoli	CRANKSHAFT without bearings and oil seals	VILEBREQUIN sans Paliers et Joints d'huile
BIELLA	CONROD	BIELLE
CAMPANA FRIZIONE	CLUTCH HOUSING	CLOCHE EMBRAYAGE
CENTRALINA AD ANTICIPO FISSO	DIGITAL IGNITION UNIT	ALLUMAGE Fixe
CENTRALINA AD ANTICIPO VARIABILE 4T	IGNITION UNIT Variable	ALLUMAGE Numérique
CINGHIA DI TRASMISSIONE TOP	TRANSMISSION BELT TOP PERFORMANCES	COURROIE DE TRANSMISSION TOP PERFORMANCES
CINGHIA DI TRASMISSIONE Mitsubishi	TRANSMISSION BELT Mitsubishi	COURROIE DE TRANSMISSION Mitsubishi
COLLETTORE ASPIRAZIONE	INLET MANIFOLD	COLLECTEUR ASPIRATION
FRIZIONE CENTRIFUGA Interno Ø 105	CENTRIFUGAL CLUTCH Ø 105	EMBAYAGE CENTRIFUGE Ø 105
FRIZIONE CENTRIFUGA Interno Ø 107	CENTRIFUGAL CLUTCH Ø 107	EMBAYAGE CENTRIFUGE Ø 107
GANASCE FRENO	BRAKE SHOES	MÂCHOIRES FREIN
GRUPPO TERMICO Ø Standard c/testa	CYLINDER KIT Ø standard with head	CYLINDRE COMPLET Ø Standard avec culasse
GRUPPO TERMICO Ø Standard s/testa	CYLINDER KIT Ø standard without head	CYLINDRE COMPLET Ø Standard sans culasse
GRUPPO TERMICO Ø Magg. c/testa	CYLINDER KIT BIG BORE with head	CYLINDRE COMPLET Ø Majoré avec culasse
GRUPPO TERMICO Ø Magg. s/testa	CYLINDER KIT BIG BORE without head	CYLINDRE COMPLET Ø Majoré sans culasse
GRUPPO TERMICO Modifica da AC a LC	CYLINDER KIT Conversion AC to LC	CYLINDRE COMPLET Modification de AC à LC
KIT CUSCINETTI DA BANCO	BEARINGS KIT	KIT PALIERS DE VILEBREQUIN
KIT REVISIONE POMPA ACQUA	WATER PUMP REPAIR KIT	KIT RÉVISION POMPE À EAU
MEMBRANA CARBURATORE	CARBURETOR DIAPHRAGM	MEMBRANE CARBURATEUR
MOTORINO D'AVVIAMENTO	STARTER ENGINE	DÉMARREUR ÉLECTRIQUE
PULEGGIA FISSA	VARIATOR SHEAVE FIXED	POULIE FIXE
RAPPORTI ALLUNGATI Primari	GÉARS KIT Primary	RAPPORTS ALLONGÉS Primaires
RAPPORTI ALLUNGATI Secondari	GÉARS KIT Secondary	RAPPORTS ALLONGÉS Secondaires
REGOLATORE DI TENSIONE	RECTIFIER	RÉGULATEUR DE TENSION
RUOTA LIBERA	STARTER CLUTCH	ROUE LIBRE
STATORE	STATOR	STATOR
VALVOLE LAMELLARI	REED VALVE	CLAPET À LAMELLES

YAMAHA	YAMAHA	YAMAHA	YAMAHA	YAMAHA	YAMAHA	YAMAHA	YAMAHA	YAMAHA	YAMAHA	YAMAHA	YAMAHA
JOG R EURO2	JOG R LC	JOG Z	JOG Z	NEO'S	NEO'S	NEO'S	NEO'S	NEO'S	NEO'S 4	NEO'S 4	NEO'S 4
13-15	02-15	95-95	95-95	97-13	02-02	04-06	07-12	12-16	09-10	11-12	12-15
50cc 2T AC	50cc 2T LC	50cc 2T	50cc 2T AC	50cc 2T AC	50cc 2T AC	50cc 2T AC	50cc 2T AC	50cc 2T AC	50cc 4T-3V LC	50cc 4T-3V LC	50cc 4T-3V LC
MY	MA	Tipo CY	Tipo CY	MY	MY	MY	MY	MY	5C3	5C3	5C3
CI07487	CI07487			CI07487	CI07487	CI07487	CI07487	CI07487			
IM07059	IM07059			IM07059	IM07059	IM07059	IM07059	IM07059			
IM07014	IM07014			IM07014	IM07014	IM07014	IM07014	IM07014			
IM07032	IM07032			IM07032	IM07032	IM07032	IM07032	IM07032			
9924940	9924940			9924940	9924940	9924940	9924940	9924940			
			9910100	9910100	9910100						
9907770	9907770			9907770	9907770	9907770	9907770	9907770			
9935270	9935270			9935270	9935270	9935270	9935270	9935270	9935600	9935600	9935600
CT00725	CT00725			CT00725	CT00725	CT00725	CT00725	CT00725			
9911060	9911060			9911060	9911060	9911060	9911060	9911060			
9910020 9925130	9910020 9925130		9925130	9910020 9925130	9910020 9925130	9910020 9925130	9910020 9925130	9910020 9925130	9925130	9925130	9925130
		CP00219									
9931140	9931110			9931140	9931140	9931140	9931140	9931140			
KT00095	KT00094		KT00095	KT00095	KT00095	KT00095	KT00095	KT00095			
9931340 KT00087	9931310 KT00109		KT00087	9931340 KT00087	9931340 KT00087	9931340 KT00087	9931340 KT00087	9931340 KT00087			
									9926330	9926330	9926330
9911090				9911090	9911090	9911090	9911090	9911090			
KK01000 KK01002	KK01000 KK01002			KK01000 KK01002	KK01000 KK01002	KK01000 KK01002	KK01000 KK01002	KK01000 KK01002			
	AA00788										
MA00001	MA00001			MA00001	MA00001	MA00001	MA00001	MA00001			
PL04055 PL04056	PL04055 PL04056			PL04055 PL04056	PL04055 PL04056	PL04055 PL04056	PL04055 PL04056	PL04055 PL04056			
9913300	9913300 9909520			9913300	9913300	9913300	9913300	9913300			
RE00015	RE00015			RE00014	RE00014	RE00014	RE00014	RE00014			
AA00767 RL00001	AA00767 RL00001			AA00767 RL00001	AA00767 RL00001	AA00767 RL00001	AA00767 RL00001	AA00767 RL00001			
9908370	9908370		9908370	9908370	9908370	9908370	9908370	9908370			

SCOOTER 50cc

SCOOTER 50cc

TOP
- performances -



YAMAHA	YAMAHA	YAMAHA	YAMAHA
NEO'S EASY	NEO'S EURO 2	RS SPY	SLIDER
13-13	02-02	95-98	00-02
50cc 2T AC	50cc 2T AC	50cc 2T AC	50cc 2T AC
MY	MY	CW	CW

IT	EN	FR					
ALBERO MESSA IN MOTO	KICK SHAFT	ARBRE DE DEMARREUR		CI07487	CI07487	CI07487	CI07487
ALBERO MOTORE Con Cuscinetti e Paraoli	CRANKSHAFT with bearings and oil seals	VILEBREQUIN doté de Paliers et Joints d'huile		IM07059	IM07059	IM07058	IM07058
ALBERO MOTORE Senza Cuscinetti e Paraoli	CRANKSHAFT without bearings and oil seals	VILEBREQUIN sans Paliers et Joints d'huile		IM07014	IM07014	IM07013	IM07013
BIELLA	CONROD	BIELLE		IM07032	IM07032	IM07032	IM07032
CAMPANA FRIZIONE	CLUTCH HOUSING	CLOCHE EMBRAYAGE		9924940	9924940		
CENTRALINA AD ANTICIPO FISSO	DIGITAL IGNITION UNIT	ALLUMAGE Fixe				9910100	9910100
CENTRALINA AD ANTICIPO VARIABILE 4T	IGNITION UNIT Variable	ALLUMAGE Numérique					
CINGHIA DI TRASMISSIONE TOP	TRANSMISSION BELT TOP PERFORMANCES	COURROIE DE TRANSMISSION TOP PERFORMANCES		9907770	9907770	9907770	9907770
CINGHIA DI TRASMISSIONE Mitsubishi	TRANSMISSION BELT Mitsubishi	COURROIE DE TRANSMISSION Mitsubishi		9935270	9935270	9935270	9935270
COLLETTORE ASPIRAZIONE	INLET MANIFOLD	COLLECTEUR ASPIRATION		CT00725	CT00725	CT00726	CT00726
FRIZIONE CENTRIFUGA Interno Ø 105	CENTRIFUGAL CLUTCH Ø 105	EMBAYAGE CENTRIFUGE Ø 105		9911060	9911060	9911060	9911060
FRIZIONE CENTRIFUGA Interno Ø 107	CENTRIFUGAL CLUTCH Ø 107	EMBAYAGE CENTRIFUGE Ø 107		9910020 9925130	9910020 9925130	9910020 9925130	9910020 9925130
GANASCE FRENO	BRAKE SHOES	MÂCHOIRES FREIN					
GRUPPO TERMICO Ø Standard c/testa	CYLINDER KIT Ø standard with head	CYLINDRE COMPLET Ø Standard avec culasse		9931140	9931140	9931170	9931170
GRUPPO TERMICO Ø Standard s/testa	CYLINDER KIT Ø standard without head	CYLINDRE COMPLET Ø Standard sans culasse		KT00095	KT00095	KT00096	KT00096
GRUPPO TERMICO Ø Magg. c/testa	CYLINDER KIT BIG BORE with head	CYLINDRE COMPLET Ø Majoré avec culasse		9931340 KT00087	9931340 KT00087	9931370 KT00088	9931370 KT00088
GRUPPO TERMICO Ø Magg. s/testa	CYLINDER KIT BIG BORE without head	CYLINDRE COMPLET Ø Majoré sans culasse					
GRUPPO TERMICO Modifica da AC a LC	CYLINDER KIT Conversion AC to LC	CYLINDRE COMPLET Modification de AC à LC		9911090	9911090		
KIT CUSCINETTI DA BANCO	BEARINGS KIT	KIT PALIERS DE VILEBREQUIN		KK01000 KK01002	KK01000 KK01002	KK01000 KK01002	KK01000 KK01002
KIT REVISIONE POMPA ACQUA	WATER PUMP REPAIR KIT	KIT RÉVISION POMPE À EAU					
MEMBRANA CARBURATORE	CARBURETOR DIAPHRAGM	MEMBRANE CARBURATEUR					
MOTORINO D'AVVIAMENTO	STARTER ENGINE	DÉMARREUR ÉLECTRIQUE		MA00001	MA00001	MA00001	MA00001
PULEGGIA FISSA	VARIATOR SHEAVE FIXED	POULIE FIXE		PL04055 PL04056	PL04055 PL04056		PL04055 PL04056
RAPPORTI ALLUNGATI Primari	GÉARS KIT Primary	RAPPORTS ALLONGÉS Primaires		9913300	9913300	9913300	9913300
RAPPORTI ALLUNGATI Secondari	GÉARS KIT Secondary	RAPPORTS ALLONGÉS Secondaires				9909520	9909520
REGOLATORE DI TENSIONE	RECTIFIER	RÉGULATEUR DE TENSION		RE00014	RE00015	RE00014	RE00014
RUOTA LIBERA	STARTER CLUTCH	ROUE LIBRE		AA00767 RL00001	AA00767 RL00001	AA00767 RL00001	AA00767 RL00001
STATORE	STATOR	STATOR					
VALVOLE LAMELLARI	REED VALVE	CLAPET À LAMELLES		9908370	9908370	9906520	9906520

YAMAHA	YAMAHA	YAMAHA	YAMAHA	YAMAHA
WHY	WHY EURO 2	ZEST	ZUMA	ZUMA
98-05	03-05	95-92	97-01	02-10
50cc 2T AC	50cc 2T AC	50cc 2T AC	50cc 2T AC	50cc 2T AC
MY	MY	CY	CW	YW
CI07487	CI07487		CI07487	
IM07059	IM07059	IM07059	IM07058	
IM07014	IM07014	IM07014	IM07013	
IM07032	IM07032	IM07032	IM07032	
9924940	9924940			
9910100		9910100	9910100	
9907770	9907770	9907900	9907770	
9935270	9935270	9935340	9935270	
CT00725	CT00725	CT00725	CT00726	
9911060	9911060		9911060	
9910020 9925130	9910020 9925130	9925130	9910020 9925130	
9931140	9931140	9931140	9931170	
KT00095	KT00095	KT00095	KT00096	
9931340 KT00087	9931340 KT00087	9931340 KT00087	9931370 KT00088	
9911090	9911090	9911090		
KK01000 KK01002	KK01000 KK01002	KK01000 KK01002	KK01000 KK01002	
MA00001	MA00001	MA00001	MA00001	
PL04055 PL04056	PL04055 PL04056	PL04055 PL04056	PL04055 PL04056	
9913300	9913300		9913300	
9909520	9909520			
RE00014	RE00015			
AA00767 RL00001	AA00767 RL00001	AA00767 RL00001	AA00767 RL00001	
9908370	9908370	9908370	9906520	9908370



SCOOTER 50cc

SCOOTER 50cc RACING

TOP
- performances -



APRILIA	APRILIA	APRILIA	APRILIA
AMICO	AMICO	AMICO GL/GLE	AMICO LX/ SPORT/CAT
94-94	96-98	93-95	92-93
50cc 2T AC	50cc 2T AC	50cc 2T AC	50cc 2T AC
CW	CW	CW	CW

IT	EN	FR				
ALBERO MOTORE TPR CORSA STD Spinotto Ø 10	CRANKSHAFT TPR Standard stroke pin Ø10	VILEBREQUIN TPR COURSE STD Axe de piston Ø 10		9927900	9927900	9927900
ALBERO MOTORE TPR CORSA STD Spinotto Ø 12	CRANKSHAFT TPR Standard stroke pin Ø12	VILEBREQUIN TPR COURSE STD Axe de piston Ø 12				
CENTRALINA RACING	RACING CDI	Unité de contrôle RACING				
CONVERTITORE DI COPPIA	REAR VARIATOR PULLEY ASSY	POULIE SECONDAIRE		9923030	9923030	9923030
COPERCHIO INGRANAGGI	GEAR COVER	COUVERCLE ENGRENAGES		9930300	9930300	9930300
CUSCINETTI DI BANCO TPR CARBONITRURATI Serie	BEARINGS TPR Carbonitrided Series	PALIERI DE VILEBREQUIN TPR CARBONITRURÉS Jeu		9929190	9929190	9929190
FRIZIONE TPR GP REGOLABILE Patented	CLUTCH TPR GP Adjustable Patented	EMBRAYAGE TPR GP RÉGLABLE Patented		9927450	9927450	9927450
GRUPPO TERMICO RACING MAGGIORATO C/TESTA (GHISA)	RACING CYLINDER KITS BIG BORE with head (CAST IRON)	CYLINDRE COMPLET RACING MAJORÉ AVEC CULASSE (FONTE)		9930000	9930000	9930000
GRUPPO TERMICO RACING 2004 C/TESTA SCOMPOSTA (GHISA)	RACING CYLINDER KITS BIG BORE without head (CAST IRON)	CYLINDRE COMPLET RACING 2004 AVEC CULASSE DÉCOMPOSÉE (FONTE)				
GRUPPO TRASFORMAZIONE DA ARIA AD ACQUA (GHISA)	CYLINDER KIT Conversion AC to LC (CAST IRON)	GROUPE TRANSFORMATION DE L'AIR À L'EAU (FONTE)				
GRUPPO TERMICO TPR IN ALLUMINIO Ø 47,6 Spinotto Ø 10	CYLINDER KIT TPR ALLUMINIUM Ø 47,6 Pin Ø 10	CYLINDRE COMPLET TPR EN ALUMINIUM Ø 47,6 Axe de Piston Ø 10		9921640	9921640	9921640
GRUPPO TERMICO TPR IN ALLUMINIO Ø 47,6 Spinotto Ø 12	CYLINDER KIT TPR ALLUMINIUM Ø 47,6 Pin Ø 12	CYLINDRE COMPLET TPR EN ALUMINIUM Ø 47,6 Axe de Piston Ø 12				
KIT ASPIRAZIONE COMPLETO MIKUNI TPR 360	COMPLETE INLET KIT MIKUNI TM 24 TPR 360	KIT ASPIRATION COMPLET MIKUNI TM 24 TPR 360				
KIT ASPIRAZIONE COMPLETO OKO 28	COMPLETE INLET KIT OKO 28 TPR 360	KIT ASPIRATION COMPLET OKO 28 TPR 360				
MAXI KIT 77 cc ALESAGGIO Ø 50 CORSA STD	MAXI KIT 77 cc Bore Ø 50 Standard stroke	MAXI KIT 77 cc ALÉSAGE Ø 50 COURSE STD				
MAXI KIT 86 cc ALESAGGIO Ø 50 CORSA 44 mm	MAXI KIT 86 cc Bore Ø 50 stroke 44 mm	MAXI KIT 86 cc ALÉSAGE Ø 50 COURSE 44 mm				
RAPPORTO ALLUNGATO secondario	SHAFT/GEARS	RAPPORT ALLONGÉ secondaire				
SERIE MOLLE CONTRASTO	VARIATOR SPRINGS SET	VARIATEUR RESSORT SET		9925620	9925620	9925620
SERIE MOLLE FRIZIONE	CLUTCH SPRINGS SET	RESSORT EMBRAYAGE SET		9908240	9908240	9908240
SCARICO NARDÒ 2 omologato	EXHAUST NARDÒ 2 Approved	ÉCHAPPEMENT NARDÒ 2 homologué		9931450	9931450	9931450
SCARICO TPR GP omologato	EXHAUST TPR GP Approved	ÉCHAPPEMENT TPR GP homologué				
VALVOLA LAMELLARE TPR	REED VALVE TPR	CLAPET À LAMELLES TPR				
VARIOTOP TPR c/cinghia	VARIOTOP TPR with belt	VARIOTOP TPR avec courroie		9931670	9931670	9931670
VARIOTOP TPR s/cinghia	VARIOTOP TPR with spring	VARIOTOP TPR avec ressort		9931650	9931650	9931650

APRILIA	APRILIA	APRILIA	APRILIA	APRILIA	APRILIA	APRILIA	APRILIA	APRILIA	APRILIA	APRILIA	APRILIA
AREA 51	GULLIVER	GULLIVER LC	MOJITO CUSTOM 2T MOTORE PIAGGIO	RALLY	RALLY LIQUID COOLED	SCARABEO	SCARABEO	SCARABEO	SCARABEO	SCARABEO 2T EU2 MOTORE PIAGGIO	SCARABEO 2T NET
98-00	95-98	96-98	04-10	95-03	96-99	93-97	98-98	99-99	00-05	10-12	09-09
50cc 2T LC	50cc 2T AC	50cc 2T LC	50cc 2T AC	50cc 2T AC	50cc 2T LC	50cc 2T AC	50cc 2T AC	50cc 2T AC	50cc 2T AC	50cc 2T AC	50cc 2T AC
MA	MY	MA	Motore Piaggio	MY	MA	MY	MY	MY	MY	Motore Piaggio	Motore Piaggio
9925910	9925910	9925910		9925910	9925910	9925910	9925910	9925910	9925910		
9928320	9928320	9928320	9926180	9928320	9928320	9928320	9928320	9928320	9928320	9926180	9926180
9923030	9923030	9923030	9923150	9923030	9923030	9923030	9923030	9923030	9923030	9923150	9923150
9930300	9930300	9930300		9930300	9930300	9930300	9930300	9930300	9930300		
9929190	9929190	9929190	9929200	9929190	9929190	9929190	9929190	9929190	9929190	9929200	9929200
9927450	9927450	9927450	9928340	9927450	9927450	9927450	9927450	9927450	9927450	9928340	9928340
9912800	9930030	9912800	9930060	9930030	9912800	9930030	9930030	9930030	9930030	9930060	9930060
9921160		9921160			9921160						
	9911210			9911210		9911210	9911210	9911210	9911210		
9928480	9921630	9928480		9921630	9928480	9921630	9921630	9921630	9921630		
9928550		9928550	9921550		9928550					9921550	9921550
9930830	9930830	9930830	9930870	9930830	9930830	9930830	9930830	9930830	9930830	9930870	9930870
9931710	9931710	9931710	9931730	9931710	9931710	9931710	9931710	9931710	9931710	9931730	9931730
9926580		9926580			9926580						
9926560		9926560			9926560						
990875P	990875P	990875P		990875P	990875P						
9925620	9925620	9925620	9925630	9925620	9925620	9925620	9925620	9925620	9925620	9925630	9925630
9908240 9912740	9908240 9912740	9908240 9912740		9908240 9912740	9908240 9912740	9908240 9912740	9908240 9912740	9908240 9912740	9908240 9912740		
9931440	9931440	9931440		9931440	9931440	9931440	9931440			9931460	9931460
9930140		9930140			9930140						
9931620	9931620	9931620	9931640	9931620	9931620	9931620	9931620	9931620	9931620	9931640	9931640
9931670	9931670	9931670	9931300	9931670	9931670	9931670	9931670	9931670	9931670		
9931650	9931650	9931650	9927610	9931650	9931650	9931650	9931650	9931650	9931650	9927610	9927610

SCOOTER 50cc
RACING

SCOOTER 50cc RACING

TOP
- performances -



APRILIA	APRILIA	APRILIA	APRILIA
SCARABEO 2T NET	SCARABEO 4T	SCARABEO 4T 4V	SCARABEO 4T 4V NET
10-10	02-06	10-12	09-09
50cc 2T AC	50cc 4T AC	50cc 4T-4V AC	50cc 4T-4V AC
Motore Piaggio	Motore Piaggio	Motore Piaggio	Motore Piaggio

IT	EN	FR				
ALBERO MOTORE TPR CORSA STD Spinotto Ø 10	CRANKSHAFT TPR Standard stroke pin Ø10	VILEBREQUIN TPR COURSE STD Axe de piston Ø 10				
ALBERO MOTORE TPR CORSA STD Spinotto Ø 12	CRANKSHAFT TPR Standard stroke pin Ø12	VILEBREQUIN TPR COURSE STD Axe de piston Ø 12		9926180		
CENTRALINA RACING	RACING CDI	Unité de contrôle RACING				
CONVERTITORE DI COPPIA	REAR VARIATOR PULLEY ASSY	POULIE SECONDAIRE		9923150	9923150	9923150
COPERCHIO INGRANAGGI	GEAR COVER	COUVERCLE ENGRENAGES				
CUSCINETTI DI BANCO TPR CARBONITRURATI Serie	BEARINGS TPR Carbonitrided Series	PALIERI DE VILEBREQUIN TPR CARBONITRURÉS Jeu		9929200		
FRIZIONE TPR GP REGOLABILE Patented	CLUTCH TPR GP Adjustable Patented	EMBAYAGE TPR GP RÉGLABLE Patented		9928340	9928340	9928340
GRUPPO TERMICO RACING MAGGIORATO C/TESTA (GHISA)	RACING CYLINDER KITS BIG BORE with head (CAST IRON)	CYLINDRE COMPLET RACING MAJORÉ AVEC CULASSE (FONTE)		9930060		
GRUPPO TERMICO RACING 2004 C/TESTA SCOMPOSTA (GHISA)	RACING CYLINDER KITS BIG BORE without head (CAST IRON)	CYLINDRE COMPLET RACING 2004 AVEC CULASSE DÉCOMPOSÉE (FONTE)				
GRUPPO TRASFORMAZIONE DA ARIA AD ACQUA (GHISA)	CYLINDER KIT Conversion AC to LC (CAST IRON)	GROUPE TRANSFORMATION DE L'AIR À L'EAU (FONTE)				
GRUPPO TERMICO TPR IN ALLUMINIO Ø 47,6 Spinotto Ø 10	CYLINDER KIT TPR ALLUMINIUM Ø 47,6 Pin Ø 10	CYLINDRE COMPLET TPR EN ALUMINIUM Ø 47,6 Axe de Piston Ø 10				
GRUPPO TERMICO TPR IN ALLUMINIO Ø 47,6 Spinotto Ø 12	CYLINDER KIT TPR ALLUMINIUM Ø 47,6 Pin Ø 12	CYLINDRE COMPLET TPR EN ALUMINIUM Ø 47,6 Axe de Piston Ø 12		9921550		
KIT ASPIRAZIONE COMPLETO MIKUNI TPR 360	COMPLETE INLET KIT MIKUNI TM 24 TPR 360	KIT ASPIRATION COMPLET MIKUNI TM 24 TPR 360		9930870		
KIT ASPIRAZIONE COMPLETO OKO 28	COMPLETE INLET KIT OKO 28 TPR 360	KIT ASPIRATION COMPLET OKO 28 TPR 360		9931730		
MAXI KIT 77 cc ALESAGGIO Ø 50 CORSA STD	MAXI KIT 77 cc Bore Ø 50 Standard stroke	MAXI KIT 77 cc ALÉSAGE Ø 50 COURSE STD				
MAXI KIT 86 cc ALESAGGIO Ø 50 CORSA 44 mm	MAXI KIT 86 cc Bore Ø 50 stroke 44 mm	MAXI KIT 86 cc ALÉSAGE Ø 50 COURSE 44 mm				
RAPPORTO ALLUNGATO secondario	SHAFT/GEARS	RAPPORT ALLONGÉ secondaire				
SERIE MOLLE CONTRASTO	VARIATOR SPRINGS SET	VARIATEUR RESSORT SET		9925630	9925630	9925630
SERIE MOLLE FRIZIONE	CLUTCH SPRINGS SET	RESSORT EMBRAYAGE SET				
SCARICO NARDÒ 2 omologato	EXHAUST NARDÒ 2 Approved	ÉCHAPPEMENT NARDÒ 2 homologué		9931460		
SCARICO TPR GP omologato	EXHAUST TPR GP Approved	ÉCHAPPEMENT TPR GP homologué				
VALVOLA LAMELLARE TPR	REED VALVE TPR	CLAPET À LAMELLES TPR		9931640		
VARIOTOP TPR c/cinghia	VARIOTOP TPR with belt	VARIOTOP TPR avec courroie				
VARIOTOP TPR s/cinghia	VARIOTOP TPR with spring	VARIOTOP TPR avec ressort		9927610	9927610	9927610

APRILIA	APRILIA	APRILIA	APRILIA	APRILIA	APRILIA	APRILIA	APRILIA	APRILIA	APRILIA	APRILIA	APRILIA
SCARABEO 4T 4V NET	SCARABEO 4T RESTYLING EU3	SCARABEO QUATTRO	SCARABEO STREET	SCARABEO STREET 2T RESTYLING	SONIC	SONIC GP	SPORT CITY ONE 2T	SPORT CITY ONE 4T	SR (ORIZZON-TALE)	SR (VERTI-CALE)	SR LIQUID COOLED
10-10	06-09	09-09	05-06	06-09	98-07	98-08	08-11	08-10	94-96	93-93	94-96
50cc 4T-4V AC	50cc 4T AC	50cc 4T-4V AC	50cc 2T AC	50cc 2T AC	50cc 2T AC	50cc 2T LC	50cc 2T AC	50cc 4T AC	50cc 2T AC	50cc 2T AC	50cc 2T LC
Motore Piaggio	Motore Piaggio	Motore Piaggio	Motore Piaggio	Motore Piaggio	CY	CA	Motore Piaggio	Motore Piaggio	MY	CW	MA
					9925910	9925910			9925910	9927900	9925910
			9926180	9926180	9928320	9928320	9926180		9928320		9928320
9923150	9923150	9923150	9923150	9923150	9923030	9923030	9923150	9923150	9923030	9923030	9923030
									9930300	9930300	9930300
			9929200	9929200	9929190	9929190	9929200		9929190	9929190	9929190
9928340	9928340	9928340	9928340	9928340	9927450	9927450	9928340	9928340	9927450	9927450	9927450
			9930060	9930060	9930030	9912800	9930060		9930030	9930000	9912800
						9921160					9921160
					9911210				9911210		
					9921630	9928480			9921630	9921640	9928480
			9921550	9921550		9928550	9921550				9928550
			9930870	9930870	9930830	9930830	9930870		9930830		9930830
			9931730	9931730	9931710	9931710	9931730		9931710		9931710
						9926580					9926580
						9926560					9926560
									990875P	990875P	990875P
9925630	9925630	9925630	9925630	9925630	9925620	9925620	9925630	9925630	9925620	9925620	9925620
					9908240 9912740	9908240 9912740			9908240	9908240	9908240 9912740
			9931460	9931460	9931440	9931440			9931440	9931450	9931440
						9930140					9930140
			9931640	9931640	9931620	9931620	9931640		9931620		9931620
					9931690	9931690			9931670	9931670	9931670
	9927610	9927610	9927610	9927610	9931650	9931650	9927610	9927610	9931650	9931650	9931650

SCOOTER 50cc RACING

SCOOTER 50cc RACING

TOP
- performances -



APRILIA	APRILIA	APRILIA	APRILIA
SR MOTARD	SR R	SR R FACTORY CARBURATORE	SR R FACTORY IE
12-14	04-09	10-14	10-12
50cc 2T LC	50cc 2T LC	50cc 2T LC	50cc 2T-IE LC
Motore Piaggio	Motore Piaggio	Motore Piaggio	Motore Piaggio

IT	EN	FR				
ALBERO MOTORE TPR CORSA STD Spinotto Ø 10	CRANKSHAFT TPR Standard stroke pin Ø10	VILEBREQUIN TPR COURSE STD Axe de piston Ø 10				
ALBERO MOTORE TPR CORSA STD Spinotto Ø 12	CRANKSHAFT TPR Standard stroke pin Ø12	VILEBREQUIN TPR COURSE STD Axe de piston Ø 12		9926180	9926180	9926180
CENTRALINA RACING	RACING CDI	Unité de contrôle RACING				
CONVERTITORE DI COPPIA	REAR VARIATOR PULLEY ASSY	POULIE SECONDAIRE		9923150	9923150	9923150
COPERCHIO INGRANAGGI	GEAR COVER	COUVERCLE ENGRENAGES				
CUSCINETTI DI BANCO TPR CARBONITRURATI Serie	BEARINGS TPR Carbonitrided Series	PALIERI DE VILEBREQUIN TPR CARBONITRURÉS Jeu		9929200	9929200	9929200
FRIZIONE TPR GP REGOLABILE Patented	CLUTCH TPR GP Adjustable Patented	EMBAYAGE TPR GP RÉGLABLE Patented		9928340	9928340	9928340
GRUPPO TERMICO RACING MAGGIORATO C/TESTA (GHISA)	RACING CYLINDER KITS BIG BORE with head (CAST IRON)	CYLINDRE COMPLET RACING MAJORÉ AVEC CULASSE (FONTE)		9920590	9920590	9920590
GRUPPO TERMICO RACING 2004 C/TESTA SCOMPOSTA (GHISA)	RACING CYLINDER KITS BIG BORE without head (CAST IRON)	CYLINDRE COMPLET RACING 2004 AVEC CULASSE DÉCOMPOSÉE (FONTE)				
GRUPPO TRASFORMAZIONE DA ARIA AD ACQUA (GHISA)	CYLINDER KIT Conversion AC to LC (CAST IRON)	GROUPE TRANSFORMATION DE L'AIR À L'EAU (FONTE)				
GRUPPO TERMICO TPR IN ALLUMINIO Ø 47,6 Spinotto Ø 10	CYLINDER KIT TPR ALLUMINIUM Ø 47,6 Pin Ø 10	CYLINDRE COMPLET TPR EN ALUMINIUM Ø 47,6 Axe de Piston Ø 10				
GRUPPO TERMICO TPR IN ALLUMINIO Ø 47,6 Spinotto Ø 12	CYLINDER KIT TPR ALLUMINIUM Ø 47,6 Pin Ø 12	CYLINDRE COMPLET TPR EN ALUMINIUM Ø 47,6 Axe de Piston Ø 12		9928520	9928520	9928520
KIT ASPIRAZIONE COMPLETO MIKUNI TPR 360	COMPLETE INLET KIT MIKUNI TM 24 TPR 360	KIT ASPIRATION COMPLET MIKUNI TM 24 TPR 360		9930870	9930870	9930870
KIT ASPIRAZIONE COMPLETO OKO 28	COMPLETE INLET KIT OKO 28 TPR 360	KIT ASPIRATION COMPLET OKO 28 TPR 360		9931730	9931730	9931730
MAXI KIT 77 cc ALESAGGIO Ø 50 CORSA STD	MAXI KIT 77 cc Bore Ø 50 Standard stroke	MAXI KIT 77 cc ALÉSAGE Ø 50 COURSE STD		9928390	9928390	9928390
MAXI KIT 86 cc ALESAGGIO Ø 50 CORSA 44 mm	MAXI KIT 86 cc Bore Ø 50 stroke 44 mm	MAXI KIT 86 cc ALÉSAGE Ø 50 COURSE 44 mm		9928440	9928440	9928440
RAPPORTO ALLUNGATO secondario	SHAFT/GEARS	RAPPORT ALLONGÉ secondaire				
SERIE MOLLE CONTRASTO	VARIATOR SPRINGS SET	VARIATEUR RESSORT SET		9925630	9925630	9925630
SERIE MOLLE FRIZIONE	CLUTCH SPRINGS SET	RESSORT EMBRAYAGE SET				
SCARICO NARDÒ 2 omologato	EXHAUST NARDÒ 2 Approved	ÉCHAPPEMENT NARDÒ 2 homologué		9931460	9931460	9931460
SCARICO TPR GP omologato	EXHAUST TPR GP Approved	ÉCHAPPEMENT TPR GP homologué		9930160	9930160	9930160
VALVOLA LAMELLARE TPR	REED VALVE TPR	CLAPET À LAMELLES TPR		9931640	9931640	9931640
VARIOTOP TPR c/cinghia	VARIOTOP TPR with belt	VARIOTOP TPR avec courroie		9931300	9931300	9931300
VARIOTOP TPR s/cinghia	VARIOTOP TPR with spring	VARIOTOP TPR avec ressort		9927610	9927610	9927610

APRILIA	APRILIA	APRILIA	APRILIA	APRILIA	ATALA	BENELLI	BENELLI	BENELLI	BENELLI	BENELLI	BENELLI
SR R FACTORY IE	SR RACING	SR STEALTH	SR STREET CARBURATORE	SR WWW	CAROSSELLO	491 GT	491 NAKED	491 RACING	491 RR	491 SP	491 SPORT
10-14	97-99	97-00	03-12	97-01	99-01	98-99	02-02	98-99	99-01	99-99	98-99
50cc 2T LC	50cc 2T LC	50cc 2T LC	50cc 2T LC	50cc 2T AC	50cc 2T AC	50cc 2T AC	50cc 2T AC	50cc 2T LC	50cc 2T LC	50cc 2T LC	50cc 2T LC
Motore Piaggio	MA	MA	Motore Piaggio	MY	MY	MY	MY	MA	MA	MA	MA
	9925910	9925910		9925910	9925910	9925910	9925910	9925910	9925910	9925910	9925910
9926180	9928320	9928320	9926180	9928320	9928320	9928320	9928320	9928320	9928320	9928320	9928320
9923150	9923030	9923030	9923150	9923030	9923030	9923030	9923030	9923030	9923030	9923030	9923030
	9930300	9930300		9930300	9930300	9930300	9930300	9930300	9930300	9930300	9930300
9929200	9929190	9929190	9929200	9929190	9929190	9929190	9929190	9929190	9929190	9929190	9929190
9928340	9927450	9927450	9928340	9927450	9927450	9927450	9927450	9927450	9927450	9927450	9927450
9920590	9912800	9912800	9920590	9930030	9930030	9930030	9930030	9912800	9912800	9912800	9912800
	9921160	9921160						9921160	9921160	9921160	9921160
				9911210	9911210	9911210	9911210				
	9928480	9928480		9921630	9921630	9921630	9921630	9928480	9928480	9928480	9928480
9928520	9928550	9928550	9928520					9928550	9928550	9928550	9928550
9930870	9930830	9930830	9930870	9930830	9930830	9930830	9930830	9930830	9930830	9930830	9930830
9931730	9931710	9931710	9931730	9931710	9931710	9931710	9931710	9931710	9931710	9931710	9931710
9928390	9926580	9926580	9928390					9926580	9926580	9926580	9926580
9928440	9926560	9926560	9928440					9926560	9926560	9926560	9926560
	990875P	990875P		990875P	990875P	990875P	990875P	990875P	990875P	990875P	990875P
9925630	9925620	9925620	9925630	9925620	9925620	9925620	9925620	9925620	9925620	9925620	9925620
	9908240 9912740	9908240 9912740		9908240	9908240	9908240 9912740	9908240 9912740	9908240 9912740	9908240 9912740	9908240 9912740	9908240 9912740
9931460	9931440	9931440		9931440		9931440		9931440			
9930160	9930140	9930140						9930140	9930140	9930140	9930140
9931640	9931620	9931620	9931640	9931620	9931620	9931620	9931620	9931620	9931620	9931620	9931620
9931300	9931670	9931670	9931300	9931670	9931670	9931670	9931670	9931670	9931670	9931670	9931670
9927610	9931650	9931650	9927610	9931650	9931650	9931650	9931650	9931650	9931650	9931650	9931650

SCOOTER 50cc
RACING

SCOOTER 50cc RACING

TOP
- performances -



BENELLI	BENELLI	BENELLI	BENELLI
491 ST	K2	K2 LIQUID COOLED	PEPE
99-01	98-01	98-01	99-01
50cc 2T AC	50cc 2T AC	50cc 2T LC	50cc 2T AC
MY	MY	MA	MY

IT	EN	FR					
ALBERO MOTORE TPR CORSA STD Spinotto Ø 10	CRANKSHAFT TPR Standard stroke pin Ø10	VILEBREQUIN TPR COURSE STD Axe de piston Ø 10		9925910	9925910	9925910	9925910
ALBERO MOTORE TPR CORSA STD Spinotto Ø 12	CRANKSHAFT TPR Standard stroke pin Ø12	VILEBREQUIN TPR COURSE STD Axe de piston Ø 12		9928320	9928320	9928320	9928320
CENTRALINA RACING	RACING CDI	Unité de contrôle RACING					
CONVERTITORE DI COPPIA	REAR VARIATOR PULLEY ASSY	POULIE SECONDAIRE		9923030	9923030	9923030	9923030
COPERCHIO INGRANAGGI	GEAR COVER	COUVERCLE ENGRENAGES		9930300	9930300	9930300	9930300
CUSCINETTI DI BANCO TPR CARBONITRURATI Serie	BEARINGS TPR Carbonitrided Series	PALIERI DE VILEBREQUIN TPR CARBONITRURÉS Jeu		9929190	9929190	9929190	9929190
FRIZIONE TPR GP REGOLABILE Patented	CLUTCH TPR GP Adjustable Patented	EMBRAYAGE TPR GP RÉGLABLE Patented		9927450	9927450	9927450	9927450
GRUPPO TERMICO RACING MAGGIORATO C/TESTA (GHISA)	RACING CYLINDER KITS BIG BORE with head (CAST IRON)	CYLINDRE COMPLET RACING MAJORÉ AVEC CULASSE (FONTE)		9930030	9930030	9912800	9930030
GRUPPO TERMICO RACING 2004 C/TESTA SCOMPOSTA (GHISA)	RACING CYLINDER KITS BIG BORE without head (CAST IRON)	CYLINDRE COMPLET RACING 2004 AVEC CULASSE DÉCOMPOSÉE (FONTE)				9921160	
GRUPPO TRASFORMAZIONE DA ARIA AD ACQUA (GHISA)	CYLINDER KIT Conversion AC to LC (CAST IRON)	GROUPE TRANSFORMATION DE L'AIR À L'EAU (FONTE)		9911210	9911210		9911210
GRUPPO TERMICO TPR IN ALLUMINIO Ø 47,6 Spinotto Ø 10	CYLINDER KIT TPR ALLUMINIUM Ø 47,6 Pin Ø 10	CYLINDRE COMPLET TPR EN ALUMINIUM Ø 47,6 Axe de Piston Ø 10		9921630	9921630	9928480	9921630
GRUPPO TERMICO TPR IN ALLUMINIO Ø 47,6 Spinotto Ø 12	CYLINDER KIT TPR ALLUMINIUM Ø 47,6 Pin Ø 12	CYLINDRE COMPLET TPR EN ALUMINIUM Ø 47,6 Axe de Piston Ø 12				9928550	
KIT ASPIRAZIONE COMPLETO MIKUNI TPR 360	COMPLETE INLET KIT MIKUNI TM 24 TPR 360	KIT ASPIRATION COMPLET MIKUNI TM 24 TPR 360		9930830	9930830	9930830	9930830
KIT ASPIRAZIONE COMPLETO OKO 28	COMPLETE INLET KIT OKO 28 TPR 360	KIT ASPIRATION COMPLET OKO 28 TPR 360		9931710	9931710	9931710	9931710
MAXI KIT 77 cc ALESAGGIO Ø 50 CORSA STD	MAXI KIT 77 cc Bore Ø 50 Standard stroke	MAXI KIT 77 cc ALÉSAGE Ø 50 COURSE STD				9926580	
MAXI KIT 86 cc ALESAGGIO Ø 50 CORSA 44 mm	MAXI KIT 86 cc Bore Ø 50 stroke 44 mm	MAXI KIT 86 cc ALÉSAGE Ø 50 COURSE 44 mm				9926560	
RAPPORTO ALLUNGATO secondario	SHAFT/GEARS	RAPPORT ALLONGÉ secondaire		990875P	990875P	990875P	990875P
SERIE MOLLE CONTRASTO	VARIATOR SPRINGS SET	VARIATEUR RESSORT SET		9925620	9925620	9925620	9925620
SERIE MOLLE FRIZIONE	CLUTCH SPRINGS SET	RESSORT EMBRAYAGE SET		9908240 9912740	9908240 9912740	9908240 9912740	9908240 9912740
SCARICO NARDÒ 2 omologato	EXHAUST NARDÒ 2 Approved	ÉCHAPPEMENT NARDÒ 2 homologué			9931440	9931440	9931440
SCARICO TPR GP omologato	EXHAUST TPR GP Approved	ÉCHAPPEMENT TPR GP homologué				9930140	
VALVOLA LAMELLARE TPR	REED VALVE TPR	CLAPET À LAMELLES TPR		9931620	9931620	9931620	9931620
VARIOTOP TPR c/cinghia	VARIOTOP TPR with belt	VARIOTOP TPR avec courroie		9931670	9931670	9931670	9931670
VARIOTOP TPR s/cinghia	VARIOTOP TPR with spring	VARIOTOP TPR avec ressort		9931650	9931650	9931650	9931650

BENELLI	BENELLI	BENELLI	BENELLI	BENELLI	BENELLI	BENELLI	BENELLI	BETA	BETA	BETA	BETA
PEPE	PEPE LX	PEPE LX	PEPE OLD	PEPE OLD	QUATTRONO-NEX	QUATTRONO-NEX	QUATTRONO-NEX	ARK	ARK LC	CHRONO	CHRONO
10-10	03-04	07-09	07-09	11-11	08-09	10-10	11-11	96-08	96-08	95-97	96-96
50cc 2T AC	50cc 2T AC	50cc 2T AC	50cc 2T AC	50cc 2T AC	50cc 2T AC	50cc 2T AC	50cc 2T AC	50cc 2T AC	50cc 2T LC	50cc 2T AC	50cc 2T AC
Tipo Keeway	MY	Tipo Keeway	Tipo Keeway	Tipo Keeway	Tipo Keeway	Tipo Keeway	Tipo Keeway	MY	MA	MY	MY
	9925910							9925910	9925910	9925910	9925910
	9928320							9928320	9928320	9928320	9928320
9923030	9923030	9923030	9923030	9923030	9923030	9923030	9923030	9923030	9923030	9923030	9923030
	9930300							9930300	9930300	9930300	9930300
	9929190							9929190	9929190	9929190	9929190
	9927450							9927450	9927450	9927450	9927450
	9930030							9930030	9912800	9930030	9930030
									9921160		
	9911210							9911210		9911210	9911210
	9921630							9921630	9928480	9921630	9921630
									9928550		
9930830	9930830	9930830	9930830	9930830	9930830	9930830	9930830	9930830	9930830	9930830	9930830
9931710	9931710	9931710	9931710	9931710	9931710	9931710	9931710	9931710	9931710	9931710	9931710
									9926580		
									9926560		
	990875P							990875P	990875P	990875P	990875P
9925620	9925620	9925620	9925620	9925620	9925620	9925620	9925620	9925620	9925620	9925620	9925620
9908240 9912740	9908240 9912740							9908240 9912740	9908240 9912740	9908240 9912740	9908240 9912740
								9931440	9931440	9931440	9931440
									9930140		
9931620	9931620	9931620	9931620	9931620	9931620	9931620	9931620	9931620	9931620	9931620	9931620
	9931670							9931670	9931670	9931670	9931670
9924900	9931650	9924900	9924900	9924900	9924900	9924900	9924900	9931650	9931650	9931650	9931650

SCOOTER 50cc RACING

SCOOTER 50cc RACING

TOP
- performances -



BETA	BETA	BETA	BETA
EIKON	QUADRA	QUADRA	TEMPO
99-03	95-95	99-01	93-02
50cc 2T LC	50cc 2T AC	50cc 2T AC	50cc 2T AC
MA	MY	MY	MY

IT	EN	FR					
ALBERO MOTORE TPR CORSA STD Spinotto Ø 10	CRANKSHAFT TPR Standard stroke pin Ø10	VILEBREQUIN TPR COURSE STD Axe de piston Ø 10		9925910	9925910	9925910	9925910
ALBERO MOTORE TPR CORSA STD Spinotto Ø 12	CRANKSHAFT TPR Standard stroke pin Ø12	VILEBREQUIN TPR COURSE STD Axe de piston Ø 12		9928320	9928320	9928320	9928320
CENTRALINA RACING	RACING CDI	Unité de contrôle RACING					
CONVERTITORE DI COPPIA	REAR VARIATOR PULLEY ASSY	POULIE SECONDAIRE		9923030	9923030	9923030	9923030
COPERCHIO INGRANAGGI	GEAR COVER	COUVERCLE ENGRENAGES		9930300	9930300	9930300	9930300
CUSCINETTI DI BANCO TPR CARBONITRURATI Serie	BEARINGS TPR Carbonitrided Series	PALIERI DE VILEBREQUIN TPR CARBONITRURÉS Jeu		9929190	9929190	9929190	9929190
FRIZIONE TPR GP REGOLABILE Patented	CLUTCH TPR GP Adjustable Patented	EMBRAYAGE TPR GP RÉGLABLE Patented		9927450	9927450		9927450
GRUPPO TERMICO RACING MAGGIORATO C/TESTA (GHISA)	RACING CYLINDER KITS BIG BORE with head (CAST IRON)	CYLINDRE COMPLET RACING MAJORÉ AVEC CULASSE (FONTE)		9912800	9930030	9930030	9930030
GRUPPO TERMICO RACING 2004 C/TESTA SCOMPOSTA (GHISA)	RACING CYLINDER KITS BIG BORE without head (CAST IRON)	CYLINDRE COMPLET RACING 2004 AVEC CULASSE DÉCOMPOSÉE (FONTE)		9921160			
GRUPPO TRASFORMAZIONE DA ARIA AD ACQUA (GHISA)	CYLINDER KIT Conversion AC to LC (CAST IRON)	GROUPE TRANSFORMATION DE L'AIR À L'EAU (FONTE)			9911210	9911210	9911210
GRUPPO TERMICO TPR IN ALLUMINIO Ø 47,6 Spinotto Ø 10	CYLINDER KIT TPR ALLUMINIUM Ø 47,6 Pin Ø 10	CYLINDRE COMPLET TPR EN ALUMINIUM Ø 47,6 Axe de Piston Ø 10		9928480	9921630	9921630	9921630
GRUPPO TERMICO TPR IN ALLUMINIO Ø 47,6 Spinotto Ø 12	CYLINDER KIT TPR ALLUMINIUM Ø 47,6 Pin Ø 12	CYLINDRE COMPLET TPR EN ALUMINIUM Ø 47,6 Axe de Piston Ø 12		9928550			
KIT ASPIRAZIONE COMPLETO MIKUNI TPR 360	COMPLETE INLET KIT MIKUNI TM 24 TPR 360	KIT ASPIRATION COMPLET MIKUNI TM 24 TPR 360		9930830	9930830	9930830	9930830
KIT ASPIRAZIONE COMPLETO OKO 28	COMPLETE INLET KIT OKO 28 TPR 360	KIT ASPIRATION COMPLET OKO 28 TPR 360		9931710	9931710	9931710	9931710
MAXI KIT 77 cc ALESAGGIO Ø 50 CORSA STD	MAXI KIT 77 cc Bore Ø 50 Standard stroke	MAXI KIT 77 cc ALÉSAGE Ø 50 COURSE STD		9926580			
MAXI KIT 86 cc ALESAGGIO Ø 50 CORSA 44 mm	MAXI KIT 86 cc Bore Ø 50 stroke 44 mm	MAXI KIT 86 cc ALÉSAGE Ø 50 COURSE 44 mm		9926560			
RAPPORTO ALLUNGATO secondario	SHAFT/GEARS	RAPPORT ALLONGÉ secondaire		990875P	990875P	990875P	990875P
SERIE MOLLE CONTRASTO	VARIATOR SPRINGS SET	VARIATEUR RESSORT SET		9925620	9925620	9925620	9925620
SERIE MOLLE FRIZIONE	CLUTCH SPRINGS SET	RESSORT EMBRAYAGE SET		9908240 9912740	9908240 9912740	9908240 9912740	9908240 9912740
SCARICO NARDÒ 2 omologato	EXHAUST NARDÒ 2 Approved	ÉCHAPPEMENT NARDÒ 2 homologué		9931440	9931440	9931440	9931440
SCARICO TPR GP omologato	EXHAUST TPR GP Approved	ÉCHAPPEMENT TPR GP homologué		9930140			
VALVOLA LAMELLARE TPR	REED VALVE TPR	CLAPET À LAMELLES TPR		9931620	9931620	9931620	9931620
VARIOTOP TPR c/cinghia	VARIOTOP TPR with belt	VARIOTOP TPR avec courroie		9931670	9931670	9931670	9931670
VARIOTOP TPR s/cinghia	VARIOTOP TPR with spring	VARIOTOP TPR avec ressort		9931650	9931650	9931650	9931650

BETA	CPI	CPI	CPI	CPI	DERBI	DERBI	DERBI	DERBI	DERBI	DERBI	DERBI
TEMPO	ARAGON	HUSSAR	OLIVER	POP CORN	ATLANTIS 2T	ATLANTIS 2T EU2	ATLANTIS 4T	ATLANTIS 4T EU2	ATLANTIS 02	ATLANTIS 02 BULLET	ATLANTIS 02 CITY
95-95	03-03	03-03	03-03	03-03	10-10	07-09	04-06	07-07	02-02	03-05	04-06
50cc 2T AC	50cc 2T AC	50cc 2T AC	50cc 2T AC	50cc 2T AC	50cc 2T AC	50cc 2T AC	50cc 4T AC	50cc 4T AC	50cc 2T AC	50cc 2T AC	50cc 2T AC
MY	Tipo Keeway	Tipo Keeway	Tipo Keeway	Tipo Keeway	Motore Piaggio	Motore Piaggio	Motore Piaggio	Motore Piaggio	Motore Piaggio	Motore Piaggio	Motore Piaggio
9925910											
9928320					9926180	9926180			9926180	9926180	9926180
9923030	9923030	9923030	9923030	9923030	9923150	9923150			9923150	9923150	9923150
9930300											
9929190					9929200	9929200				9929200	9929200
9927450					9928340	9928340	9928340	9928340	9928340	9928340	9928340
9930030					9930060	9930060			9930060	9930060	9930060
9911210											
9921630											
					9921550	9921550			9921550	9921550	9921550
9930830	9930830	9930830	9930830	9930830	9930870	9930870			9930870	9930870	9930870
9931710	9931710	9931710	9931710	9931710	9931730	9931730			9931730	9931730	9931730
990875P											
9925620	9925620	9925620	9925620	9925620	9925630	9925630	9925630	9925630	9925630	9925630	9925630
9908240 9912740											
9931440					9931460	9931460			9931460	9931460	9931460
9931620	9931620	9931620	9931620	9931620	9931640	9931640			9931640	9931640	9931640
9931670					9931300	9931300			9931300	9931300	9931300
9931650	9924900	9924900	9924900	9924900	9927610	9927610			9927610	9927610	9927610

SCOOTER 50cc RACING

SCOOTER 50cc RACING

TOP
- performances -



DERBI	DERBI	DERBI	DERBI
ATLANTIS 02 RED BULLET	ATLANTIS 02 TWO CHIC	BOULEVARD 2T	BOULEVARD 4T EU2 25KM/H
03-03	05-05	09-14	09-09
50cc 2T AC	50cc 2T AC	50cc 2T AC	50cc 4T AC
Motore Piaggio	Motore Piaggio	Motore Piaggio	Motore Piaggio

IT	EN	FR				
ALBERO MOTORE TPR CORSA STD Spinotto Ø 10	CRANKSHAFT TPR Standard stroke pin Ø10	VILEBREQUIN TPR COURSE STD Axe de piston Ø 10				
ALBERO MOTORE TPR CORSA STD Spinotto Ø 12	CRANKSHAFT TPR Standard stroke pin Ø12	VILEBREQUIN TPR COURSE STD Axe de piston Ø 12		9926180	9926180	9926180
CENTRALINA RACING	RACING CDI	Unité de contrôle RACING				
CONVERTITORE DI COPPIA	REAR VARIATOR PULLEY ASSY	POULIE SECONDAIRE		9923150	9923150	9923150
COPERCHIO INGRANAGGI	GEAR COVER	COUVERCLE ENGRENAGES				
CUSCINETTI DI BANCO TPR CARBONITRURATI Serie	BEARINGS TPR Carbonitrided Series	PALIERI DE VILEBREQUIN TPR CARBONITRURÉS Jeu		9929200	9929200	
FRIZIONE TPR GP REGOLABILE Patented	CLUTCH TPR GP Adjustable Patented	EMBRAYAGE TPR GP RÉGLABLE Patented		9928340	9928340	9928340
GRUPPO TERMICO RACING MAGGIORATO C/TESTA (GHISA)	RACING CYLINDER KITS BIG BORE with head (CAST IRON)	CYLINDRE COMPLET RACING MAJORÉ AVEC CULASSE (FONTE)		9930060	9930060	9930060
GRUPPO TERMICO RACING 2004 C/TESTA SCOMPOSTA (GHISA)	RACING CYLINDER KITS BIG BORE without head (CAST IRON)	CYLINDRE COMPLET RACING 2004 AVEC CULASSE DÉCOMPOSÉE (FONTE)				
GRUPPO TRASFORMAZIONE DA ARIA AD ACQUA (GHISA)	CYLINDER KIT Conversion AC to LC (CAST IRON)	GROUPE TRANSFORMATION DE L'AIR À L'EAU (FONTE)				
GRUPPO TERMICO TPR IN ALLUMINIO Ø 47,6 Spinotto Ø 10	CYLINDER KIT TPR ALLUMINIUM Ø 47,6 Pin Ø 10	CYLINDRE COMPLET TPR EN ALUMINIUM Ø 47,6 Axe de Piston Ø 10				
GRUPPO TERMICO TPR IN ALLUMINIO Ø 47,6 Spinotto Ø 12	CYLINDER KIT TPR ALLUMINIUM Ø 47,6 Pin Ø 12	CYLINDRE COMPLET TPR EN ALUMINIUM Ø 47,6 Axe de Piston Ø 12		9921550	9921550	9921550
KIT ASPIRAZIONE COMPLETO MIKUNI TPR 360	COMPLETE INLET KIT MIKUNI TM 24 TPR 360	KIT ASPIRATION COMPLET MIKUNI TM 24 TPR 360		9930870	9930870	9930870
KIT ASPIRAZIONE COMPLETO OKO 28	COMPLETE INLET KIT OKO 28 TPR 360	KIT ASPIRATION COMPLET OKO 28 TPR 360		9931730	9931730	9931730
MAXI KIT 77 cc ALESAGGIO Ø 50 CORSA STD	MAXI KIT 77 cc Bore Ø 50 Standard stroke	MAXI KIT 77 cc ALÉSAGE Ø 50 COURSE STD				
MAXI KIT 86 cc ALESAGGIO Ø 50 CORSA 44 mm	MAXI KIT 86 cc Bore Ø 50 stroke 44 mm	MAXI KIT 86 cc ALÉSAGE Ø 50 COURSE 44 mm				
RAPPORTO ALLUNGATO secondario	SHAFT/GEARS	RAPPORT ALLONGÉ secondaire				
SERIE MOLLE CONTRASTO	VARIATOR SPRINGS SET	VARIATEUR RESSORT SET		9925630	9925630	9925630
SERIE MOLLE FRIZIONE	CLUTCH SPRINGS SET	RESSORT EMBRAYAGE SET				
SCARICO NARDÒ 2 omologato	EXHAUST NARDÒ 2 Approved	ÉCHAPPEMENT NARDÒ 2 homologué		9931460	9931460	9931460
SCARICO TPR GP omologato	EXHAUST TPR GP Approved	ÉCHAPPEMENT TPR GP homologué				
VALVOLA LAMELLARE TPR	REED VALVE TPR	CLAPET À LAMELLES TPR		9931640	9931640	9931640
VARIOTOP TPR c/cinghia	VARIOTOP TPR with belt	VARIOTOP TPR avec courroie		9931300	9931300	
VARIOTOP TPR s/cinghia	VARIOTOP TPR with spring	VARIOTOP TPR avec ressort		9927610	9927610	9927610

DERBI	DERBI	DERBI	DERBI	DERBI	DERBI	EXPLORER	GARELLI	GILERA	GILERA	GILERA	GILERA
GP1	GP1	GP1 EU 2	GP1 OPEN EU2	GP1 RACE EU2	SONAR 2T	CRACKER	GPS	DNA	DNA	DNA GP EXPERIENCE	EASY MOVING
01-02	03-03	05-05	06-09	05-07	09-09	03-03	09-11	00-02	05-07	03-04	95-96
50cc 2T LC	50cc 2T LC	50cc 2T LC	50cc 2T LC	50cc 2T LC	50cc 2T AC	50cc 2T AC	50cc 2T LC	50cc 2T LC	50cc 2T LC	50cc 2T LC	50cc 2T AC
Motore Piaggio	Motore Piaggio	Motore Piaggio	Motore Piaggio	Motore Piaggio	Motore Piaggio	Tipo Keeway	Tipo MA	Motore Piaggio	Motore Piaggio	Motore Piaggio	Motore Piaggio
9926180	9926180	9926180	9926180	9926180	9926180			9926180	9926180	9926180	9926180
9923150	9923150	9923150	9923150	9923150	9923150	9923030					9923150
9929200	9929200	9929200	9929200	9929200	9929200			9929200	9929200	9929200	9929200
9928340	9928340	9928340	9928340	9928340	9928340			9928340	9928340	9928340	9928340
9920590	9920590	9920590	9920590	9920590	9930060			9920590	9920590	9920590	9930060
9928520	9928520	9928520	9928520	9928520	9921550			9928520	9928520	9928520	9921550
9930870	9930870	9930870	9930870	9930870	9930870	9930830	9930830	9930870	9930870	9930870	9930870
9931730	9931730	9931730	9931730	9931730	9931730	9931710	9931710	9931730	9931730	9931730	9931730
9928390	9928390	9928390	9928390	9928390				9928390	9928390	9928390	
9928440	9928440	9928440	9928440	9928440				9928440	9928440	9928440	
9925630	9925630	9925630	9925630	9925630	9925630	9925620	9925620	9925630	9925630	9925630	9925630
							9912740				
9931460	9931460	9931460	9931460	9931460	9931460			9931460	9931460	9931460	9931460
9930160	9930160	9930160	9930160	9930160				9930160	9930160	9930160	
9931640	9931640	9931640	9931640	9931640	9931640	9931620		9931640	9931640	9931640	9931640
9931300	9931300	9931300	9931300	9931300							
9927610	9927610	9927610	9927610	9927610	9927610	9924900		9927610	9927610	9927610	9927610

SCOOTER 50cc RACING

SCOOTER 50cc RACING

TOP
- performances -



GILERA	GILERA	GILERA	GILERA
ICE	RUNNER	RUNNER POGGIALI	RUNNER PURE JET
01-05	97-00	02-02	02-04
50cc 2T AC	50cc 2T LC	50cc 2T LC	50cc 2T-IE LC
Motore Piaggio	Motore Piaggio	Motore Piaggio	Motore Piaggio

IT	EN	FR				
ALBERO MOTORE TPR CORSA STD Spinotto Ø 10	CRANKSHAFT TPR Standard stroke pin Ø10	VILEBREQUIN TPR COURSE STD Axe de piston Ø 10				
ALBERO MOTORE TPR CORSA STD Spinotto Ø 12	CRANKSHAFT TPR Standard stroke pin Ø12	VILEBREQUIN TPR COURSE STD Axe de piston Ø 12		9926180	9926180	9926180
CENTRALINA RACING	RACING CDI	Unité de contrôle RACING				
CONVERTITORE DI COPPIA	REAR VARIATOR PULLEY ASSY	POULIE SECONDAIRE		9923150	9923150	9923150
COPERCHIO INGRANAGGI	GEAR COVER	COUVERCLE ENGRENAGES				
CUSCINETTI DI BANCO TPR CARBONITRURATI Serie	BEARINGS TPR Carbonitrided Series	PALIERI DE VILEBREQUIN TPR CARBONITRURÉS Jeu		9929200	9929200	9929200
FRIZIONE TPR GP REGOLABILE Patented	CLUTCH TPR GP Adjustable Patented	EMBAYAGE TPR GP RÉGLABLE Patented		9928340	9928340	9928340
GRUPPO TERMICO RACING MAGGIORATO C/TESTA (GHISA)	RACING CYLINDER KITS BIG BORE with head (CAST IRON)	CYLINDRE COMPLET RACING MAJORÉ AVEC CULASSE (FONTE)		9930060	9920590	9920590
GRUPPO TERMICO RACING 2004 C/TESTA SCOMPOSTA (GHISA)	RACING CYLINDER KITS BIG BORE without head (CAST IRON)	CYLINDRE COMPLET RACING 2004 AVEC CULASSE DÉCOMPOSÉE (FONTE)				
GRUPPO TRASFORMAZIONE DA ARIA AD ACQUA (GHISA)	CYLINDER KIT Conversion AC to LC (CAST IRON)	GROUPE TRANSFORMATION DE L'AIR À L'EAU (FONTE)				
GRUPPO TERMICO TPR IN ALLUMINIO Ø 47,6 Spinotto Ø 10	CYLINDER KIT TPR ALLUMINIUM Ø 47,6 Pin Ø 10	CYLINDRE COMPLET TPR EN ALUMINIUM Ø 47,6 Axe de Piston Ø 10				
GRUPPO TERMICO TPR IN ALLUMINIO Ø 47,6 Spinotto Ø 12	CYLINDER KIT TPR ALLUMINIUM Ø 47,6 Pin Ø 12	CYLINDRE COMPLET TPR EN ALUMINIUM Ø 47,6 Axe de Piston Ø 12		9921550	9928520	9928520
KIT ASPIRAZIONE COMPLETO MIKUNI TPR 360	COMPLETE INLET KIT MIKUNI TM 24 TPR 360	KIT ASPIRATION COMPLET MIKUNI TM 24 TPR 360		9930870	9930870	9930870
KIT ASPIRAZIONE COMPLETO OKO 28	COMPLETE INLET KIT OKO 28 TPR 360	KIT ASPIRATION COMPLET OKO 28 TPR 360		9931730	9931730	9931730
MAXI KIT 77 cc ALESAGGIO Ø 50 CORSA STD	MAXI KIT 77 cc Bore Ø 50 Standard stroke	MAXI KIT 77 cc ALÉSAGE Ø 50 COURSE STD			9928390	9928390
MAXI KIT 86 cc ALESAGGIO Ø 50 CORSA 44 mm	MAXI KIT 86 cc Bore Ø 50 stroke 44 mm	MAXI KIT 86 cc ALÉSAGE Ø 50 COURSE 44 mm			9928440	9928440
RAPPORTO ALLUNGATO secondario	SHAFT/GEARS	RAPPORT ALLONGÉ secondaire				
SERIE MOLLE CONTRASTO	VARIATOR SPRINGS SET	VARIATEUR RESSORT SET		9925630	9925630	9925630
SERIE MOLLE FRIZIONE	CLUTCH SPRINGS SET	RESSORT EMBRAYAGE SET				
SCARICO NARDÒ 2 omologato	EXHAUST NARDÒ 2 Approved	ÉCHAPPEMENT NARDÒ 2 homologué		9931460	9931460	9931460
SCARICO TPR GP omologato	EXHAUST TPR GP Approved	ÉCHAPPEMENT TPR GP homologué		9930160	9930160	9930160
VALVOLA LAMELLARE TPR	REED VALVE TPR	CLAPET À LAMELLES TPR		9931640	9931640	9931640
VARIOTOP TPR c/cinghia	VARIOTOP TPR with belt	VARIOTOP TPR avec courroie		9931300	9931300	9931300
VARIOTOP TPR s/cinghia	VARIOTOP TPR with spring	VARIOTOP TPR avec ressort		9927610	9927610	9927610

GILERA	GILERA	GILERA	GILERA	GILERA	GILERA	GILERA	GILERA	GILERA	GILERA	GILERA	GILERA
RUNNER PURE JET	RUNNER PURE JET	RUNNER PURE JET	RUNNER PURE JET ST	RUNNER SP	RUNNER SP	RUNNER SP	RUNNER SP	RUNNER SP SPECIAL EDITION	RUNNER SP ST & SIMONCELLI	STALKER	STALKER
05-06	07-07	10-11	08-08	02-04	05-06	07-07	10-12	07-07	08-09	97-04	05-06
50cc 2T-IE LC	50cc 2T-IE LC	50cc 2T-IE LC	50cc 2T-IE LC	50cc 2T LC	50cc 2T LC	50cc 2T LC	50cc 2T LC	50cc 2T LC	50cc 2T LC	50cc 2T AC	50cc 2T AC
Motore Piaggio	Motore Piaggio	Motore Piaggio	Motore Piaggio	Motore Piaggio	Motore Piaggio	Motore Piaggio	Motore Piaggio	Motore Piaggio	Motore Piaggio	Motore Piaggio	Motore Piaggio
				9926180	9926180	9926180	9926180	9926180	9926180	9926180	9926180
9923150	9923150	9923150		9923150	9923150					9923150	9923150
9929200	9929200	9929200	9929200	9929200	9929200	9929200	9929200	9929200	9929200	9929200	9929200
9928340	9928340	9928340	9928340	9928340	9928340	9928340	9928340	9928340	9928340	9928340	9928340
				9920590	9920590	9920590	9920590	9920590	9920590	9930060	9930060
				9928520	9928520	9928520	9928520	9928520	9928520	9921550	9921550
				9930870	9930870	9930870	9930870	9930870	9930870	9930870	9930870
				9931730	9931730	9931730	9931730	9931730	9931730	9931730	9931730
				9928390	9928390	9928390	9928390	9928390	9928390		
				9928440	9928440	9928440	9928440	9928440	9928440		
9925630	9925630	9925630	9925630	9925630	9925630	9925630	9925630	9925630	9925630	9925630	9925630
9931460	9931460	9931460	9931460	9931460	9931460	9931460	9931460	9931460	9931460	9931460	9931460
				9930160	9930160	9930160	9930160	9930160	9930160		
9931640	9931640	9931640	9931640	9931640	9931640	9931640	9931640	9931640	9931640	9931640	9931640
9931300	9931300	9931300		9931300						9931300	9931300
9927610	9927610	9927610		9927610	9927610	9927610	9927610	9927610	9927610	9927610	9927610

SCOOTER 50cc RACING

SCOOTER 50cc RACING

TOP
- performances -



GILERA	GILERA	GILERA	GILERA
STALKER	STALKER	STALKER NAKED	STALKER SPECIAL EDITION
07-08	09-11	08-08	07-08
50cc 2T AC	50cc 2T AC	50cc 2T AC	50cc 2T AC
Motore Piaggio	Motore Piaggio	Motore Piaggio	Motore Piaggio

IT	EN	FR				
ALBERO MOTORE TPR CORSA STD Spinotto Ø 10	CRANKSHAFT TPR Standard stroke pin Ø10	VILEBREQUIN TPR COURSE STD Axe de piston Ø 10				
ALBERO MOTORE TPR CORSA STD Spinotto Ø 12	CRANKSHAFT TPR Standard stroke pin Ø12	VILEBREQUIN TPR COURSE STD Axe de piston Ø 12		9926180	9926180	9926180
CENTRALINA RACING	RACING CDI	Unité de contrôle RACING				
CONVERTITORE DI COPPIA	REAR VARIATOR PULLEY ASSY	POULIE SECONDAIRE		9923150	9923150	9923150
COPERCHIO INGRANAGGI	GEAR COVER	COUVERCLE ENGRENAGES				
CUSCINETTI DI BANCO TPR CARBONITRURATI Serie	BEARINGS TPR Carbonitrided Series	PALIERI DE VILEBREQUIN TPR CARBONITRURÉS Jeu		9929200	9929200	9929200
FRIZIONE TPR GP REGOLABILE Patented	CLUTCH TPR GP Adjustable Patented	EMBAYAGE TPR GP RÉGLABLE Patented		9928340	9928340	9928340
GRUPPO TERMICO RACING MAGGIORATO C/TESTA (GHISA)	RACING CYLINDER KITS BIG BORE with head (CAST IRON)	CYLINDRE COMPLET RACING MAJORÉ AVEC CULASSE (FONTE)		9930060	9930060	9930060
GRUPPO TERMICO RACING 2004 C/TESTA SCOMPOSTA (GHISA)	RACING CYLINDER KITS BIG BORE without head (CAST IRON)	CYLINDRE COMPLET RACING 2004 AVEC CULASSE DÉCOMPOSÉE (FONTE)				
GRUPPO TRASFORMAZIONE DA ARIA AD ACQUA (GHISA)	CYLINDER KIT Conversion AC to LC (CAST IRON)	GROUPE TRANSFORMATION DE L'AIR À L'EAU (FONTE)				
GRUPPO TERMICO TPR IN ALLUMINIO Ø 47,6 Spinotto Ø 10	CYLINDER KIT TPR ALLUMINIUM Ø 47,6 Pin Ø 10	CYLINDRE COMPLET TPR EN ALUMINIUM Ø 47,6 Axe de Piston Ø 10				
GRUPPO TERMICO TPR IN ALLUMINIO Ø 47,6 Spinotto Ø 12	CYLINDER KIT TPR ALLUMINIUM Ø 47,6 Pin Ø 12	CYLINDRE COMPLET TPR EN ALUMINIUM Ø 47,6 Axe de Piston Ø 12		9921550	9921550	9921550
KIT ASPIRAZIONE COMPLETO MIKUNI TPR 360	COMPLETE INLET KIT MIKUNI TM 24 TPR 360	KIT ASPIRATION COMPLET MIKUNI TM 24 TPR 360		9930870	9930870	9930870
KIT ASPIRAZIONE COMPLETO OKO 28	COMPLETE INLET KIT OKO 28 TPR 360	KIT ASPIRATION COMPLET OKO 28 TPR 360		9931730	9931730	9931730
MAXI KIT 77 cc ALESAGGIO Ø 50 CORSA STD	MAXI KIT 77 cc Bore Ø 50 Standard stroke	MAXI KIT 77 cc ALÉSAGE Ø 50 COURSE STD				
MAXI KIT 86 cc ALESAGGIO Ø 50 CORSA 44 mm	MAXI KIT 86 cc Bore Ø 50 stroke 44 mm	MAXI KIT 86 cc ALÉSAGE Ø 50 COURSE 44 mm				
RAPPORTO ALLUNGATO secondario	SHAFT/GEARS	RAPPORT ALLONGÉ secondaire				
SERIE MOLLE CONTRASTO	VARIATOR SPRINGS SET	VARIATEUR RESSORT SET		9925630	9925630	9925630
SERIE MOLLE FRIZIONE	CLUTCH SPRINGS SET	RESSORT EMBRAYAGE SET				
SCARICO NARDÒ 2 omologato	EXHAUST NARDÒ 2 Approved	ÉCHAPPEMENT NARDÒ 2 homologué		9931460	9931460	9931460
SCARICO TPR GP omologato	EXHAUST TPR GP Approved	ÉCHAPPEMENT TPR GP homologué				
VALVOLA LAMELLARE TPR	REED VALVE TPR	CLAPET À LAMELLES TPR		9931640	9931640	9931640
VARIOTOP TPR c/cinghia	VARIOTOP TPR with belt	VARIOTOP TPR avec courroie		9931300	9931300	9931300
VARIOTOP TPR s/cinghia	VARIOTOP TPR with spring	VARIOTOP TPR avec ressort		9927610	9927610	9927610

GILERA	GILERA	GILERA	GILERA	GILERA	ITALJET	ITALJET	ITALJET	ITALJET	ITALJET	ITALJET	ITALJET
STORM	STORM EURO 2	TYPHOON	TYPHOON X	TYPHOON XR	BAZOOKA	DRAGSTER	JET SET	PISTA	PISTA 2	SCOOP	SCOOP 2
94-95	07-07	94-97	98-99	00-00	91-94	98-02	02-02	92-97	97-98	91-95	96-98
50cc 2T AC	50cc 2T AC	50cc 2T AC	50cc 2T AC	50cc 2T AC	50cc 2T AC	50cc 2T LC	50cc 2T AC	50cc 2T AC	50cc 2T AC	50cc 2T AC	50cc 2T AC
Motore Piaggio	Motore Piaggio	Motore Piaggio	Motore Piaggio	Motore Piaggio	Tipo CW	MA	Motore Piaggio	Tipo CW	Tipo CW	Tipo CW	Tipo CW
						9925910					
9926180	9926180	9926180	9926180	9926180		9928320	9926180				
9923150	9923150	9923150	9923150	9923150		9923030	9923150				
						9930300					
9929200	9929200	9929200	9929200	9929200		9929190	9929200				
9928340	9928340	9928340	9928340	9928340	9927450	9927450	9928340	9927450	9927450	9927450	9927450
9930060	9930060	9930060	9930060	9930060		9912800	9930060				
						9921160					
						9928480					
9921550	9921550	9921550	9921550	9921550		9928550	9921550				
9930870	9930870	9930870	9930870	9930870		9930830	9930870				
9931730	9931730	9931730	9931730	9931730		9931710	9931730				
						9926580					
						9926560					
						990875P					
9925630	9925630	9925630	9925630	9925630		9925620	9925630				
					9908240	9908240 9912740		9908240	9908240	9908240	9908240
9931460	9931460	9931460	9931460	9931460	9931450	9931440	9931460	9931450	9931450	9931450	9931450
						9930140					
9931640	9931640	9931640	9931640	9931640		9931620	9931640				
	9931300			9931300		9931670					
9927610	9927610	9927610	9927610	9927610		9931650	9927610				

SCOOTER 50cc
RACING

SCOOTER 50cc RACING

TOP
- performances -



ITALJET	ITALJET	ITALJET	KEEWAY
TORPEDO	TORPEDO NEW	YANKEE	F-ACT
97-00	00-01	93-97	07-08
50cc 4T AC	50cc 2T AC	50cc 2T AC	50cc 2T AC
Motore Piaggio	Motore Piaggio	Tipo CW	Motore Keeway

IT	EN	FR				
ALBERO MOTORE TPR CORSA STD Spinotto Ø 10	CRANKSHAFT TPR Standard stroke pin Ø10	VILEBREQUIN TPR COURSE STD Axe de piston Ø 10				
ALBERO MOTORE TPR CORSA STD Spinotto Ø 12	CRANKSHAFT TPR Standard stroke pin Ø12	VILEBREQUIN TPR COURSE STD Axe de piston Ø 12		9926180		
CENTRALINA RACING	RACING CDI	Unité de contrôle RACING				
CONVERTITORE DI COPPIA	REAR VARIATOR PULLEY ASSY	POULIE SECONDAIRE		9923150		9923030
COPERCHIO INGRANAGGI	GEAR COVER	COUVERCLE ENGRENAGES				
CUSCINETTI DI BANCO TPR CARBONITRURATI Serie	BEARINGS TPR Carbonitrided Series	PALIERI DE VILEBREQUIN TPR CARBONITRURÉS Jeu		9929200		
FRIZIONE TPR GP REGOLABILE Patented	CLUTCH TPR GP Adjustable Patented	EMBAYAGE TPR GP RÉGLABLE Patented		9928340	9928340	9927450
GRUPPO TERMICO RACING MAGGIORATO C/TESTA (GHISA)	RACING CYLINDER KITS BIG BORE with head (CAST IRON)	CYLINDRE COMPLET RACING MAJORÉ AVEC CULASSE (FONTE)		9930060		
GRUPPO TERMICO RACING 2004 C/TESTA SCOMPOSTA (GHISA)	RACING CYLINDER KITS BIG BORE without head (CAST IRON)	CYLINDRE COMPLET RACING 2004 AVEC CULASSE DÉCOMPOSÉE (FONTE)				
GRUPPO TRASFORMAZIONE DA ARIA AD ACQUA (GHISA)	CYLINDER KIT Conversion AC to LC (CAST IRON)	GROUPE TRANSFORMATION DE L'AIR À L'EAU (FONTE)				
GRUPPO TERMICO TPR IN ALLUMINIO Ø 47,6 Spinotto Ø 10	CYLINDER KIT TPR ALLUMINIUM Ø 47,6 Pin Ø 10	CYLINDRE COMPLET TPR EN ALUMINIUM Ø 47,6 Axe de Piston Ø 10				
GRUPPO TERMICO TPR IN ALLUMINIO Ø 47,6 Spinotto Ø 12	CYLINDER KIT TPR ALLUMINIUM Ø 47,6 Pin Ø 12	CYLINDRE COMPLET TPR EN ALUMINIUM Ø 47,6 Axe de Piston Ø 12		9921550		
KIT ASPIRAZIONE COMPLETO MIKUNI TPR 360	COMPLETE INLET KIT MIKUNI TM 24 TPR 360	KIT ASPIRATION COMPLET MIKUNI TM 24 TPR 360		9930870		9930830
KIT ASPIRAZIONE COMPLETO OKO 28	COMPLETE INLET KIT OKO 28 TPR 360	KIT ASPIRATION COMPLET OKO 28 TPR 360		9931730		9931710
MAXI KIT 77 cc ALESAGGIO Ø 50 CORSA STD	MAXI KIT 77 cc Bore Ø 50 Standard stroke	MAXI KIT 77 cc ALÉSAGE Ø 50 COURSE STD				
MAXI KIT 86 cc ALESAGGIO Ø 50 CORSA 44 mm	MAXI KIT 86 cc Bore Ø 50 stroke 44 mm	MAXI KIT 86 cc ALÉSAGE Ø 50 COURSE 44 mm				
RAPPORTO ALLUNGATO secondario	SHAFT/GEARS	RAPPORT ALLONGÉ secondaire				
SERIE MOLLE CONTRASTO	VARIATOR SPRINGS SET	VARIATEUR RESSORT SET		9925630	9925630	9925620
SERIE MOLLE FRIZIONE	CLUTCH SPRINGS SET	RESSORT EMBRAYAGE SET				9908240
SCARICO NARDÒ 2 omologato	EXHAUST NARDÒ 2 Approved	ÉCHAPPEMENT NARDÒ 2 homologué		9931460		9931450
SCARICO TPR GP omologato	EXHAUST TPR GP Approved	ÉCHAPPEMENT TPR GP homologué				
VALVOLA LAMELLARE TPR	REED VALVE TPR	CLAPET À LAMELLES TPR		9931640		9931620
VARIOTOP TPR c/cinghia	VARIOTOP TPR with belt	VARIOTOP TPR avec courroie				
VARIOTOP TPR s/cinghia	VARIOTOP TPR with spring	VARIOTOP TPR avec ressort		9927610	9927610	9924900

KEEWAY	KEEWAY	KEEWAY	KEEWAY	KEEWAY	KEEWAY	KEEWAY	KTM	KYMCO	KYMCO	KYMCO	KYMCO
FLASH	FOCUS	GOCCIA	HURRICANE	MATRIX	PIXEL EURO 2	RY8	K50	AGILITY 4T CARRY	AGILITY 4T R10	AGILITY 4T R10	AGILITY 4T R12
07-08	06-06	09-09	06-08	06-08	09-12	08-08	96-01	11-11	06-06	07-08	07-08
50cc 2T AC	50cc 2T AC	50cc 2T AC	50cc 2T AC	50cc 2T AC	50cc 2T AC	50cc 2T AC	50cc 2T AC	50cc 4T AC	50cc 4T AC	50cc 4T AC	50cc 4T AC
Motore Keeway	Motore Keeway	Motore Keeway	Motore Keeway	Motore Keeway	Motore Keeway	Motore Keeway	MY	Motore Kymco	Motore Kymco	Motore Kymco	Motore Kymco
							9925910				
							9928320				
9923030	9923030	9923030	9923030	9923030	9923030	9923030	9923030				
							9930300				
							9929190				
							9927450				
							9930030				
							9911210				
							9921630				
9930830	9930830	9930830	9930830	9930830	9930830	9930830	9930830				
9931710	9931710	9931710	9931710	9931710	9931710	9931710	9931710				
							990875P				
9925620	9925620	9925620	9925620	9925620	9925620	9925620	9925620				
							9908240		9912740	9912740	9912740
9931620	9931620	9931620	9931620	9931620	9931620	9931620	9931620				
							9931670				
9924900	9924900	9924900	9924900	9924900	9924900	9924900	9931650	9937610	9937610	9937610	9937610

SCOOTER 50cc RACING

SCOOTER 50cc RACING

TOP
- performances -



KYMC0	KYMC0	KYMC0	KYMC0
AGILITY 4T R16 PLUS EURO4	AGILITY CARRY 4T EURO4	AGILITY PLUS 4T	AGILITY R12
19-19	19-19	14-14	05-05
50cc 4T AC	50cc 4T AC	50cc 4T AC	50cc 4T AC
Motore Kymco	Motore Kymco	Motore Kymco	Motore Kymco

IT	EN	FR				
ALBERO MOTORE TPR CORSA STD Spinotto Ø 10	CRANKSHAFT TPR Standard stroke pin Ø10	VILEBREQUIN TPR COURSE STD Axe de piston Ø 10				
ALBERO MOTORE TPR CORSA STD Spinotto Ø 12	CRANKSHAFT TPR Standard stroke pin Ø12	VILEBREQUIN TPR COURSE STD Axe de piston Ø 12				
CENTRALINA RACING	RACING CDI	Unité de contrôle RACING				
CONVERTITORE DI COPPIA	REAR VARIATOR PULLEY ASSY	POULIE SECONDAIRE				
COPERCHIO INGRANAGGI	GEAR COVER	COUVERCLE ENGRENAGES				
CUSCINETTI DI BANCO TPR CARBONITRURATI Serie	BEARINGS TPR Carbonitrided Series	PALIERI DE VILEBREQUIN TPR CARBONITRURÉS Jeu				
FRIZIONE TPR GP REGOLABILE Patented	CLUTCH TPR GP Adjustable Patented	EMBRAYAGE TPR GP RÉGLABLE Patented				
GRUPPO TERMICO RACING MAGGIORATO C/TESTA (GHISA)	RACING CYLINDER KITS BIG BORE with head (CAST IRON)	CYLINDRE COMPLET RACING MAJORÉ AVEC CULASSE (FONTE)				
GRUPPO TERMICO RACING 2004 C/TESTA SCOMPOSTA (GHISA)	RACING CYLINDER KITS BIG BORE without head (CAST IRON)	CYLINDRE COMPLET RACING 2004 AVEC CULASSE DÉCOMPOSÉE (FONTE)				
GRUPPO TRASFORMAZIONE DA ARIA AD ACQUA (GHISA)	CYLINDER KIT Conversion AC to LC (CAST IRON)	GROUPE TRANSFORMATION DE L'AIR À L'EAU (FONTE)				
GRUPPO TERMICO TPR IN ALLUMINIO Ø 47,6 Spinotto Ø 10	CYLINDER KIT TPR ALLUMINIUM Ø 47,6 Pin Ø 10	CYLINDRE COMPLET TPR EN ALUMINIUM Ø 47,6 Axe de Piston Ø 10				
GRUPPO TERMICO TPR IN ALLUMINIO Ø 47,6 Spinotto Ø 12	CYLINDER KIT TPR ALLUMINIUM Ø 47,6 Pin Ø 12	CYLINDRE COMPLET TPR EN ALUMINIUM Ø 47,6 Axe de Piston Ø 12				
KIT ASPIRAZIONE COMPLETO MIKUNI TPR 360	COMPLETE INLET KIT MIKUNI TM 24 TPR 360	KIT ASPIRATION COMPLET MIKUNI TM 24 TPR 360				
KIT ASPIRAZIONE COMPLETO OKO 28	COMPLETE INLET KIT OKO 28 TPR 360	KIT ASPIRATION COMPLET OKO 28 TPR 360				
MAXI KIT 77 cc ALESAGGIO Ø 50 CORSA STD	MAXI KIT 77 cc Bore Ø 50 Standard stroke	MAXI KIT 77 cc ALÉSAGE Ø 50 COURSE STD				
MAXI KIT 86 cc ALESAGGIO Ø 50 CORSA 44 mm	MAXI KIT 86 cc Bore Ø 50 stroke 44 mm	MAXI KIT 86 cc ALÉSAGE Ø 50 COURSE 44 mm				
RAPPORTO ALLUNGATO secondario	SHAFT/GEARS	RAPPORT ALLONGÉ secondaire				
SERIE MOLLE CONTRASTO	VARIATOR SPRINGS SET	VARIATEUR RESSORT SET				
SERIE MOLLE FRIZIONE	CLUTCH SPRINGS SET	RESSORT EMBRAYAGE SET				9912740
SCARICO NARDÒ 2 omologato	EXHAUST NARDÒ 2 Approved	ÉCHAPPEMENT NARDÒ 2 homologué				
SCARICO TPR GP omologato	EXHAUST TPR GP Approved	ÉCHAPPEMENT TPR GP homologué				
VALVOLA LAMELLARE TPR	REED VALVE TPR	CLAPET À LAMELLES TPR				
VARIOTOP TPR c/cinghia	VARIOTOP TPR with belt	VARIOTOP TPR avec courroie				
VARIOTOP TPR s/cinghia	VARIOTOP TPR with spring	VARIOTOP TPR avec ressort		9937610	9937610	9937610

KYMC0	KYMC0	KYMC0	KYMC0	KYMC0	KYMC0	KYMC0	KYMC0	KYMC0	KYMC0	KYMC0	KYMC0
AGILITY R12 ECS	AGILITY R16	AGILITY R16	AGILITY R16	AGILITY R16 2T	AGILITY R16 2T	AGILITY RS	AGILITY RS NAKED	B&W	B&W EU2	CX	CX SUPER
16-16	08-08	09-09	12-12	10-10	12-12	09-09	10-10	02-02	03-03	93-93	94-97
50cc 4T AC	50cc 4T AC	50cc 4T AC	50cc 4T AC	50cc 2T AC	50cc 2T AC	50cc 4T AC	50cc 2T AC	50cc 2T LC	50cc 2T LC	50cc 2T AC	50cc 2T AC
Motore Kymco	Motore Kymco	Motore Kymco	Motore Kymco	Motore Kymco	Motore Kymco	Motore Kymco	Motore Kymco	Motore Kymco	Motore Kymco	Motore Kymco	Motore Kymco
	9912740	9912740	9912740	9912740	9912740	9912740	9912740	9912740	9912740	9912740	9912740
9937610	9937610	9937610	9937610			9937610					

SCOOTER 50cc
RACING

SCOOTER 50cc RACING

TOP
- performances -



KYMCO	KYMCO	KYMCO	KYMCO
DINK 50 4T	DINK CLASSIC EU2	DJ WORLD	DJ X
07-07	03-03	94-00	91-92
50cc 4T AC	50cc 2T AC	50cc 2T AC	50cc 2T AC
Motore Kymco	Motore Kymco	Motore Kymco	Motore Kymco

IT	EN	FR				
ALBERO MOTORE TPR CORSA STD Spinotto Ø 10	CRANKSHAFT TPR Standard stroke pin Ø10	VILEBREQUIN TPR COURSE STD Axe de piston Ø 10				
ALBERO MOTORE TPR CORSA STD Spinotto Ø 12	CRANKSHAFT TPR Standard stroke pin Ø12	VILEBREQUIN TPR COURSE STD Axe de piston Ø 12				
CENTRALINA RACING	RACING CDI	Unité de contrôle RACING				
CONVERTITORE DI COPPIA	REAR VARIATOR PULLEY ASSY	POULIE SECONDAIRE				
COPERCHIO INGRANAGGI	GEAR COVER	COUVERCLE ENGRENAGES				
CUSCINETTI DI BANCO TPR CARBONITRURATI Serie	BEARINGS TPR Carbonitrided Series	PALIERI DE VILEBREQUIN TPR CARBONITRURÉS Jeu				
FRIZIONE TPR GP REGOLABILE Patented	CLUTCH TPR GP Adjustable Patented	EMBRAYAGE TPR GP RÉGLABLE Patented				
GRUPPO TERMICO RACING MAGGIORATO C/TESTA (GHISA)	RACING CYLINDER KITS BIG BORE with head (CAST IRON)	CYLINDRE COMPLET RACING MAJORÉ AVEC CULASSE (FONTE)				
GRUPPO TERMICO RACING 2004 C/TESTA SCOMPOSTA (GHISA)	RACING CYLINDER KITS BIG BORE without head (CAST IRON)	CYLINDRE COMPLET RACING 2004 AVEC CULASSE DÉCOMPOSÉE (FONTE)				
GRUPPO TRASFORMAZIONE DA ARIA AD ACQUA (GHISA)	CYLINDER KIT Conversion AC to LC (CAST IRON)	GROUPE TRANSFORMATION DE L'AIR À L'EAU (FONTE)				
GRUPPO TERMICO TPR IN ALLUMINIO Ø 47,6 Spinotto Ø 10	CYLINDER KIT TPR ALLUMINIUM Ø 47,6 Pin Ø 10	CYLINDRE COMPLET TPR EN ALUMINIUM Ø 47,6 Axe de Piston Ø 10				
GRUPPO TERMICO TPR IN ALLUMINIO Ø 47,6 Spinotto Ø 12	CYLINDER KIT TPR ALLUMINIUM Ø 47,6 Pin Ø 12	CYLINDRE COMPLET TPR EN ALUMINIUM Ø 47,6 Axe de Piston Ø 12				
KIT ASPIRAZIONE COMPLETO MIKUNI TPR 360	COMPLETE INLET KIT MIKUNI TM 24 TPR 360	KIT ASPIRATION COMPLET MIKUNI TM 24 TPR 360				
KIT ASPIRAZIONE COMPLETO OKO 28	COMPLETE INLET KIT OKO 28 TPR 360	KIT ASPIRATION COMPLET OKO 28 TPR 360				
MAXI KIT 77 cc ALESAGGIO Ø 50 CORSA STD	MAXI KIT 77 cc Bore Ø 50 Standard stroke	MAXI KIT 77 cc ALÉSAGE Ø 50 COURSE STD				
MAXI KIT 86 cc ALESAGGIO Ø 50 CORSA 44 mm	MAXI KIT 86 cc Bore Ø 50 stroke 44 mm	MAXI KIT 86 cc ALÉSAGE Ø 50 COURSE 44 mm				
RAPPORTO ALLUNGATO secondario	SHAFT/GEARS	RAPPORT ALLONGÉ secondaire				
SERIE MOLLE CONTRASTO	VARIATOR SPRINGS SET	VARIATEUR RESSORT SET				
SERIE MOLLE FRIZIONE	CLUTCH SPRINGS SET	RESSORT EMBRAYAGE SET		9912740	9912740	9912740
SCARICO NARDÒ 2 omologato	EXHAUST NARDÒ 2 Approved	ÉCHAPPEMENT NARDÒ 2 homologué				
SCARICO TPR GP omologato	EXHAUST TPR GP Approved	ÉCHAPPEMENT TPR GP homologué				
VALVOLA LAMELLARE TPR	REED VALVE TPR	CLAPET À LAMELLES TPR				
VARIOTOP TPR c/cinghia	VARIOTOP TPR with belt	VARIOTOP TPR avec courroie				
VARIOTOP TPR s/cinghia	VARIOTOP TPR with spring	VARIOTOP TPR avec ressort		9937610		

KYMC0	KYMC0	KYMC0	KYMC0	KYMC0	KYMC0	KYMC0	KYMC0	KYMC0	KYMC0	KYMC0	KYMC0
DJ Y	FEVER ZX	FEVER ZX EU2	FILLY	FILLY LX	HEROISM	K 12	KB	LIKE	LIKE	LIKE EURO4 4T	PEOPLE
93-93	99-00	03-04	98-00	01-02	95-97	95-00	95-00	09-09	09-09	18-18	99-03
50cc 2T AC	50cc 2T AC	50cc 2T AC	50cc 4T AC	50cc 4T AC	50cc 2T AC	50cc 2T AC	50cc 2T AC	50cc 4T AC	50cc 4T AC	50cc 4T AC	50cc 2T AC
Motore Kymco	Motore Kymco	Motore Kymco	Motore Kymco	Motore Kymco	Motore Kymco	Motore Kymco	Motore Kymco	Motore Kymco	Motore Kymco	Motore Kymco	Motore Kymco
9912740	9912740	9912740	9912740	9912740	9912740	9912740	9912740				9912740
			9937610	9937610				9937610	9937610	9937610	

SCOOTER 50cc
RACING

SCOOTER 50cc RACING

TOP
- performances -



KYMCO	KYMCO	KYMCO	KYMCO
PEOPLE	PEOPLE EURO 2	PEOPLE EURO 2	PEOPLES
04-04	03-03	08-08	05-08
50cc 2T AC	50cc 2T AC	50cc 2T AC	50cc 2T AC
Motore Kymco	Motore Kymco	Motore Kymco	Motore Kymco

IT	EN	FR				
ALBERO MOTORE TPR CORSA STD Spinotto Ø 10	CRANKSHAFT TPR Standard stroke pin Ø10	VILEBREQUIN TPR COURSE STD Axe de piston Ø 10				
ALBERO MOTORE TPR CORSA STD Spinotto Ø 12	CRANKSHAFT TPR Standard stroke pin Ø12	VILEBREQUIN TPR COURSE STD Axe de piston Ø 12				
CENTRALINA RACING	RACING CDI	Unité de contrôle RACING				
CONVERTITORE DI COPPIA	REAR VARIATOR PULLEY ASSY	POULIE SECONDAIRE				
COPERCHIO INGRANAGGI	GEAR COVER	COUVERCLE ENGRENAGES				
CUSCINETTI DI BANCO TPR CARBONITRURATI Serie	BEARINGS TPR Carbonitrided Series	PALIERI DE VILEBREQUIN TPR CARBONITRURÉS Jeu				
FRIZIONE TPR GP REGOLABILE Patented	CLUTCH TPR GP Adjustable Patented	EMBRAYAGE TPR GP RÉGLABLE Patented				
GRUPPO TERMICO RACING MAGGIORATO C/TESTA (GHISA)	RACING CYLINDER KITS BIG BORE with head (CAST IRON)	CYLINDRE COMPLET RACING MAJORÉ AVEC CULASSE (FONTE)				
GRUPPO TERMICO RACING 2004 C/TESTA SCOMPOSTA (GHISA)	RACING CYLINDER KITS BIG BORE without head (CAST IRON)	CYLINDRE COMPLET RACING 2004 AVEC CULASSE DÉCOMPOSÉE (FONTE)				
GRUPPO TRASFORMAZIONE DA ARIA AD ACQUA (GHISA)	CYLINDER KIT Conversion AC to LC (CAST IRON)	GROUPE TRANSFORMATION DE L'AIR À L'EAU (FONTE)				
GRUPPO TERMICO TPR IN ALLUMINIO Ø 47,6 Spinotto Ø 10	CYLINDER KIT TPR ALLUMINIUM Ø 47,6 Pin Ø 10	CYLINDRE COMPLET TPR EN ALUMINIUM Ø 47,6 Axe de Piston Ø 10				
GRUPPO TERMICO TPR IN ALLUMINIO Ø 47,6 Spinotto Ø 12	CYLINDER KIT TPR ALLUMINIUM Ø 47,6 Pin Ø 12	CYLINDRE COMPLET TPR EN ALUMINIUM Ø 47,6 Axe de Piston Ø 12				
KIT ASPIRAZIONE COMPLETO MIKUNI TPR 360	COMPLETE INLET KIT MIKUNI TM 24 TPR 360	KIT ASPIRATION COMPLET MIKUNI TM 24 TPR 360				
KIT ASPIRAZIONE COMPLETO OKO 28	COMPLETE INLET KIT OKO 28 TPR 360	KIT ASPIRATION COMPLET OKO 28 TPR 360				
MAXI KIT 77 cc ALESAGGIO Ø 50 CORSA STD	MAXI KIT 77 cc Bore Ø 50 Standard stroke	MAXI KIT 77 cc ALÉSAGE Ø 50 COURSE STD				
MAXI KIT 86 cc ALESAGGIO Ø 50 CORSA 44 mm	MAXI KIT 86 cc Bore Ø 50 stroke 44 mm	MAXI KIT 86 cc ALÉSAGE Ø 50 COURSE 44 mm				
RAPPORTO ALLUNGATO secondario	SHAFT/GEARS	RAPPORT ALLONGÉ secondaire				
SERIE MOLLE CONTRASTO	VARIATOR SPRINGS SET	VARIATEUR RESSORT SET				
SERIE MOLLE FRIZIONE	CLUTCH SPRINGS SET	RESSORT EMBRAYAGE SET		9912740	9912740	9912740
SCARICO NARDÒ 2 omologato	EXHAUST NARDÒ 2 Approved	ÉCHAPPEMENT NARDÒ 2 homologué				
SCARICO TPR GP omologato	EXHAUST TPR GP Approved	ÉCHAPPEMENT TPR GP homologué				
VALVOLA LAMELLARE TPR	REED VALVE TPR	CLAPET À LAMELLES TPR				
VARIOTOP TPR c/cinghia	VARIOTOP TPR with belt	VARIOTOP TPR avec courroie				
VARIOTOP TPR s/cinghia	VARIOTOP TPR with spring	VARIOTOP TPR avec ressort				

KYMCO	KYMCO	KYMCO	KYMCO	KYMCO	KYMCO	KYMCO	KYMCO	KYMCO	KYMCO	KYMCO	KYMCO
PEOPLE S 4T	SENTO	SNIPER	SNIPER DD	SUPER 8 4T	SUPER 8 4T	SUPER 9	SUPER 9 EU2	SUPER 9 EU2	VITALITY 2T	VITALITY 4T	YUP
06-08	08-08	93-93	94-96	07-07	09-09	00-00	03-03	04-04	04-04	04-04	02-02
50cc 4T AC	50cc 4T AC	50cc 2T AC	50cc 2T AC	50cc 4T AC	50cc 4T AC	50cc 2T LC	50cc 2T LC	50cc 2T LC	50cc 2T AC	50cc 4T AC	50cc 2T AC
Motore Kymco	Motore Kymco	Motore Kymco	Motore Kymco	Motore Kymco	Motore Kymco	Motore Kymco	Motore Kymco	Motore Kymco	Motore Kymco	Motore Kymco	Motore Kymco
9912740	9912740	9912740	9912740			9912740	9912740	9912740	9912740	9912740	9912740
9937610	9937610			9937610	9937610					9937610	

SCOOTER 50cc RACING

SCOOTER 50cc RACING

TOP
- performances -



KYMCO	MACAL	MACAL	MALAGUTI
YUP EU2	STING	THUNDER	CENTRO EURO 2
03-03	95-96	95-96	08-08
50cc 2T AC	50cc 2T AC	50cc 2T AC	50cc 4T AC
Motore Kymco	CY	MY	Motore Piaggio

IT	EN	FR					
ALBERO MOTORE TPR CORSA STD Spinotto Ø 10	CRANKSHAFT TPR Standard stroke pin Ø10	VILEBREQUIN TPR COURSE STD Axe de piston Ø 10				9925910	
ALBERO MOTORE TPR CORSA STD Spinotto Ø 12	CRANKSHAFT TPR Standard stroke pin Ø12	VILEBREQUIN TPR COURSE STD Axe de piston Ø 12				9928320	
CENTRALINA RACING	RACING CDI	Unité de contrôle RACING					
CONVERTITORE DI COPPIA	REAR VARIATOR PULLEY ASSY	POULIE SECONDAIRE				9923030	
COPERCHIO INGRANAGGI	GEAR COVER	COUVERCLE ENGRENAGES				9930300	
CUSCINETTI DI BANCO TPR CARBONITRURATI Serie	BEARINGS TPR Carbonitrided Series	PALIERI DE VILEBREQUIN TPR CARBONITRURÉS Jeu			9929190	9929190	
FRIZIONE TPR GP REGOLABILE Patented	CLUTCH TPR GP Adjustable Patented	EMBRAYAGE TPR GP RÉGLABLE Patented				9927450	9928340
GRUPPO TERMICO RACING MAGGIORATO C/TESTA (GHISA)	RACING CYLINDER KITS BIG BORE with head (CAST IRON)	CYLINDRE COMPLET RACING MAJORÉ AVEC CULASSE (FONTE)			9930030	9930030	
GRUPPO TERMICO RACING 2004 C/TESTA SCOMPOSTA (GHISA)	RACING CYLINDER KITS BIG BORE without head (CAST IRON)	CYLINDRE COMPLET RACING 2004 AVEC CULASSE DÉCOMPOSÉE (FONTE)					
GRUPPO TRASFORMAZIONE DA ARIA AD ACQUA (GHISA)	CYLINDER KIT Conversion AC to LC (CAST IRON)	GROUPE TRANSFORMATION DE L'AIR À L'EAU (FONTE)				9911210	
GRUPPO TERMICO TPR IN ALLUMINIO Ø 47,6 Spinotto Ø 10	CYLINDER KIT TPR ALLUMINIUM Ø 47,6 Pin Ø 10	CYLINDRE COMPLET TPR EN ALUMINIUM Ø 47,6 Axe de Piston Ø 10				9921630	
GRUPPO TERMICO TPR IN ALLUMINIO Ø 47,6 Spinotto Ø 12	CYLINDER KIT TPR ALLUMINIUM Ø 47,6 Pin Ø 12	CYLINDRE COMPLET TPR EN ALUMINIUM Ø 47,6 Axe de Piston Ø 12					
KIT ASPIRAZIONE COMPLETO MIKUNI TPR 360	COMPLETE INLET KIT MIKUNI TM 24 TPR 360	KIT ASPIRATION COMPLET MIKUNI TM 24 TPR 360			9930830	9930830	
KIT ASPIRAZIONE COMPLETO OKO 28	COMPLETE INLET KIT OKO 28 TPR 360	KIT ASPIRATION COMPLET OKO 28 TPR 360			9931710	9931710	
MAXI KIT 77 cc ALESAGGIO Ø 50 CORSA STD	MAXI KIT 77 cc Bore Ø 50 Standard stroke	MAXI KIT 77 cc ALÉSAGE Ø 50 COURSE STD					
MAXI KIT 86 cc ALESAGGIO Ø 50 CORSA 44 mm	MAXI KIT 86 cc Bore Ø 50 stroke 44 mm	MAXI KIT 86 cc ALÉSAGE Ø 50 COURSE 44 mm					
RAPPORTO ALLUNGATO secondario	SHAFT/GEARS	RAPPORT ALLONGÉ secondaire				990875P	
SERIE MOLLE CONTRASTO	VARIATOR SPRINGS SET	VARIATEUR RESSORT SET			9925620	9925620	9925630
SERIE MOLLE FRIZIONE	CLUTCH SPRINGS SET	RESSORT EMBRAYAGE SET		9912740		9908240	
SCARICO NARDÒ 2 omologato	EXHAUST NARDÒ 2 Approved	ÉCHAPPEMENT NARDÒ 2 homologué					
SCARICO TPR GP omologato	EXHAUST TPR GP Approved	ÉCHAPPEMENT TPR GP homologué					
VALVOLA LAMELLARE TPR	REED VALVE TPR	CLAPET À LAMELLES TPR				9931620	
VARIOTOP TPR c/cinghia	VARIOTOP TPR with belt	VARIOTOP TPR avec courroie				9931670	
VARIOTOP TPR s/cinghia	VARIOTOP TPR with spring	VARIOTOP TPR avec ressort				9931650	9927610

MALAGUTI	MALAGUTI	MALAGUTI	MALAGUTI	MALAGUTI	MALAGUTI	MALAGUTI	MALAGUTI	MALAGUTI	MALAGUTI	MALAGUTI	MALAGUTI
CENTRO SL	CENTRO SL 4T	CIAK	CIAK EURO 2,3	CIAK EURO2	CIAK MASTER 4T	CIAK MASTER EURO 2	CIAK MASTER EURO 2	DVD	F10	F10 AC WAP	F10 EURO 2
94-98	10-10	99-01	03-03	01-03	05-06	05-06	06-06	10-10	92-00	08-08	02-06
50cc 2T AC	50cc 4T AC	50cc 2T AC	50cc 2T AC	50cc 2T AC	50cc 4T AC	50cc 4T AC	50cc 2T AC	50cc 4T AC	50cc 2T AC	50cc 2T AC	50cc 2T AC
MY	Motore Piaggio	MY	MY	MY	Motore Piaggio	Motore Piaggio	MY	Tipo Kymco	CY	Tipo Keeway	CY
9925910		9925910	9925910	9925910			9925910		9925910		9925910
9928320		9928320	9928320	9928320			9928320		9928320		9928320
			9921210				9925780				
9923030		9923030	9923030	9923030			9923030		9923030	9923030	9923030
9930300		9930300	9930300	9930300			9930300				
9929190		9929190	9929190	9929190			9929190		9929190		9929190
9927450	9928340	9927450	9927450	9927450	9928340	9928340			9927450		9927450
9930030		9930030	9930030	9930030			9930030		9930030		9930030
9911210		9911210	9911210	9911210			9911210		9911210		9911210
9921630		9921630	9921630	9921630			9921630		9921630		9921630
9930830		9930830	9930830	9930830			9930830		9930830	9930830	9930830
9931710		9931710	9931710	9931710			9931710		9931710	9931710	9931710
990875P											
9925620	9925630	9925620	9925620	9925620	9925630	9925630	9925620		9925620	9925620	9925620
9908240		9908240 9912740	9908240 9912740	9908240 9912740			9912740		9908240		9908240 9912740
9931440		9931440	9931440	9931440			9931440		9931440		9931440
9931620		9931620	9931620	9931620			9931620		9931620	9931620	9931620
9931670		9931670	9931670	9931670			9931670		9931690		9931690
9931650		9931650	9931650	9931650	9927610		9931650	9937610	9931650	9924900	9931650

SCOOTER 50cc RACING

SCOOTER 50cc RACING

TOP
- performances -



MALAGUTI	MALAGUTI	MALAGUTI	MALAGUTI
F10 EURO 2 2,3	F10 RESTYLING EURO 2	F12 PHANTOM	F12 PHANTOM EURO 2
03-04	06-06	94-98	02-02
50cc 2T AC	50cc 2T AC	50cc 2T AC	50cc 2T LC
CY	CY	MY	MA vent.

IT	EN	FR				
ALBERO MOTORE TPR CORSA STD Spinotto Ø 10	CRANKSHAFT TPR Standard stroke pin Ø10	VILEBREQUIN TPR COURSE STD Axe de piston Ø 10		9925910	9925910	9925910
ALBERO MOTORE TPR CORSA STD Spinotto Ø 12	CRANKSHAFT TPR Standard stroke pin Ø12	VILEBREQUIN TPR COURSE STD Axe de piston Ø 12		9928320	9928320	9928320
CENTRALINA RACING	RACING CDI	Unité de contrôle RACING		9921210	9925780	
CONVERTITORE DI COPPIA	REAR VARIATOR PULLEY ASSY	POULIE SECONDAIRE		9923030	9923030	9923030
COPERCHIO INGRANAGGI	GEAR COVER	COUVERCLE ENGRENAGES				9930300
CUSCINETTI DI BANCO TPR CARBONITRURATI Serie	BEARINGS TPR Carbonitrided Series	PALIERI DE VILEBREQUIN TPR CARBONITRURÉS Jeu		9929190	9929190	9929190
FRIZIONE TPR GP REGOLABILE Patented	CLUTCH TPR GP Adjustable Patented	EMBRAYAGE TPR GP RÉGLABLE Patented		9927450		9927450
GRUPPO TERMICO RACING MAGGIORATO C/TESTA (GHISA)	RACING CYLINDER KITS BIG BORE with head (CAST IRON)	CYLINDRE COMPLET RACING MAJORÉ AVEC CULASSE (FONTE)		9930030	9930030	9930030
GRUPPO TERMICO RACING 2004 C/TESTA SCOMPOSTA (GHISA)	RACING CYLINDER KITS BIG BORE without head (CAST IRON)	CYLINDRE COMPLET RACING 2004 AVEC CULASSE DÉCOMPOSÉE (FONTE)				9921160
GRUPPO TRASFORMAZIONE DA ARIA AD ACQUA (GHISA)	CYLINDER KIT Conversion AC to LC (CAST IRON)	GROUPE TRANSFORMATION DE L'AIR À L'EAU (FONTE)		9911210	9911210	9911210
GRUPPO TERMICO TPR IN ALLUMINIO Ø 47,6 Spinotto Ø 10	CYLINDER KIT TPR ALLUMINIUM Ø 47,6 Pin Ø 10	CYLINDRE COMPLET TPR EN ALUMINIUM Ø 47,6 Axe de Piston Ø 10		9921630	9921630	9921630
GRUPPO TERMICO TPR IN ALLUMINIO Ø 47,6 Spinotto Ø 12	CYLINDER KIT TPR ALLUMINIUM Ø 47,6 Pin Ø 12	CYLINDRE COMPLET TPR EN ALUMINIUM Ø 47,6 Axe de Piston Ø 12				9928550
KIT ASPIRAZIONE COMPLETO MIKUNI TPR 360	COMPLETE INLET KIT MIKUNI TM 24 TPR 360	KIT ASPIRATION COMPLET MIKUNI TM 24 TPR 360		9930830	9930830	9930830
KIT ASPIRAZIONE COMPLETO OKO 28	COMPLETE INLET KIT OKO 28 TPR 360	KIT ASPIRATION COMPLET OKO 28 TPR 360		9931710	9931710	9931710
MAXI KIT 77 cc ALESAGGIO Ø 50 CORSA STD	MAXI KIT 77 cc Bore Ø 50 Standard stroke	MAXI KIT 77 cc ALÉSAGE Ø 50 COURSE STD				
MAXI KIT 86 cc ALESAGGIO Ø 50 CORSA 44 mm	MAXI KIT 86 cc Bore Ø 50 stroke 44 mm	MAXI KIT 86 cc ALÉSAGE Ø 50 COURSE 44 mm				
RAPPORTO ALLUNGATO secondario	SHAFT/GEARS	RAPPORT ALLONGÉ secondaire				990875P
SERIE MOLLE CONTRASTO	VARIATOR SPRINGS SET	VARIATEUR RESSORT SET		9925620	9925620	9925620
SERIE MOLLE FRIZIONE	CLUTCH SPRINGS SET	RESSORT EMBRAYAGE SET		9908240 9912740	9912740	9908240 9912740
SCARICO NARDÒ 2 omologato	EXHAUST NARDÒ 2 Approved	ÉCHAPPEMENT NARDÒ 2 homologué		9931440	9931440	9931440
SCARICO TPR GP omologato	EXHAUST TPR GP Approved	ÉCHAPPEMENT TPR GP homologué				
VALVOLA LAMELLARE TPR	REED VALVE TPR	CLAPET À LAMELLES TPR		9931620	9931620	9931620
VARIOTOP TPR c/cinghia	VARIOTOP TPR with belt	VARIOTOP TPR avec courroie		9931690	9931690	9931670
VARIOTOP TPR s/cinghia	VARIOTOP TPR with spring	VARIOTOP TPR avec ressort		9931650	9931650	9931650

MALAGUTI	MALAGUTI	MALAGUTI	MALAGUTI	MALAGUTI	MALAGUTI	MALAGUTI	MALAGUTI	MALAGUTI	MALAGUTI	MALAGUTI	MALAGUTI
F12 PHANTOM EURO 2,2,3	F12 PHANTOM LC	F12 PHANTOM LC EURO 2,2,3	F12 R PHANTOM AC	F12 R PHANTOM LC	F12 RESTYLING EURO 1	F12 RESTYLING EURO 2	F12 RESTYLING LC EURO 2	F15 FIRE FOX	F15 FIRE FOX AIR COOLED	F15 FIRE FOX EURO 2	F15 FIRE FOX EURO 2
03-04	94-98	03-04	07-08	07-10	99-02	06-06	06-06	96-98	05-06	02-03	04-06
50cc 2T AC	50cc 2T LC	50cc 2T LC	50cc 2T AC	50cc 2T LC	50cc 2T LC	50cc 2T AC	50cc 2T LC	50cc 2T LC	50cc 2T AC	50cc 2T LC	50cc 2T LC
MY	MA	MA vent.	Tipo Keeway	MA	MA vent.	MY	MA vent.	MA	MY	MA	MA
9925910	9925910			9925910		9925910		9925910	9925910	9925910	9925910
9928320	9928320			9928320		9928320		9928320	9928320	9928320	9928320
9921210		9921210		9925780		9925780	9925780		9925780		9925780
9923030	9923030	9923030	9923030	9923030	9923030	9923030	9923030	9923030	9923030	9923030	9923030
9930300	9930300	9930300		9930300	9930300	9930300	9930300	9930300	9930300	9930300	9930300
9929190	9929190	9929190		9929190	9929190	9929190	9929190	9929190	9929190	9929190	9929190
9927450	9927450	9927450			9927450	9927450		9927450		9927450	
9930030	9912800	9912800		9912800	9912800	9930030	9912800	9912800	9930030	9912800	9912800
	9921160	9921160		9921160	9921160		9921160	9921160		9921160	9921160
9911210						9911210			9911210		
9921630	9928480	9928480		9928480	9928480	9921630	9928480	9928480	9921630	9928480	9928480
	9928550	9928550		9928550	9928550		9928550	9928550		9928550	9928550
9930830	9930830	9930830	9930830	9930830	9930830	9930830	9930830	9930830	9930830	9930830	9930830
9931710	9931710	9931710	9931710	9931710	9931710	9931710	9931710	9931710	9931710	9931710	9931710
	9926580			9926580				9926580		9926580	9926580
	9926560			9926560				9926560		9926560	9926560
990875P	990875P	990875P		990875P	990875P	990875P	990875P	990875P	990875P	990875P	990875P
9925620	9925620	9925620	9925620	9925620	9925620	9925620	9925620	9925620	9925620	9925620	9925620
9908240 9912740	9908240	9908240 9912740		9912740	9912740	9908240 9912740	9912740	9908240 9912740	9912740	9908240 9912740	9912740
9931440	9931440			9931440		9931440		9931440	9931440	9931440	9931440
	9930140			9930140				9930140		9930140	9930140
9931620	9931620	9931620	9931620	9931620	9931620	9931620	9931620	9931620	9931620	9931620	9931620
9931670	9931670	9931670		9931670	9931670	9931670	9931670	9931670	9931670	9931670	9931670
9931650	9931650	9931650	9924900	9931650	9931650	9931650	9931650	9931650	9931650	9931650	9931650

SCOOTER 50cc RACING

SCOOTER 50cc RACING

TOP
- performances -



MALAGUTI	MALAGUTI	MBK	MBK
F15 FIRE FOX EURO 2,2,3	YESTERDAY	BOOSTER	BOOSTER
03-04	97-00	90-91	90-04
50cc 2T LC	50cc 2T AC	50cc 2T AC	50cc 2T AC
MA	CY	CW	CW

IT	EN	FR					
ALBERO MOTORE TPR CORSA STD Spinotto Ø 10	CRANKSHAFT TPR Standard stroke pin Ø10	VILEBREQUIN TPR COURSE STD Axe de piston Ø 10		9925910	9925910	9927900	9927900
ALBERO MOTORE TPR CORSA STD Spinotto Ø 12	CRANKSHAFT TPR Standard stroke pin Ø12	VILEBREQUIN TPR COURSE STD Axe de piston Ø 12		9928320	9928320		
CENTRALINA RACING	RACING CDI	Unité de contrôle RACING		9921210			
CONVERTITORE DI COPPIA	REAR VARIATOR PULLEY ASSY	POULIE SECONDAIRE		9923030	9923030	9923030	9923030
COPERCHIO INGRANAGGI	GEAR COVER	COUVERCLE ENGRENAGES		9930300		9930300	9930300
CUSCINETTI DI BANCO TPR CARBONITRURATI Serie	BEARINGS TPR Carbonitrided Series	PALIERI DE VILEBREQUIN TPR CARBONITRURÉS Jeu		9929190	9929190	9929190	9929190
FRIZIONE TPR GP REGOLABILE Patented	CLUTCH TPR GP Adjustable Patented	EMBRAYAGE TPR GP RÉGLABLE Patented		9927450	9927450	9927450	9927450
GRUPPO TERMICO RACING MAGGIORATO C/TESTA (GHISA)	RACING CYLINDER KITS BIG BORE with head (CAST IRON)	CYLINDRE COMPLET RACING MAJORÉ AVEC CULASSE (FONTE)		9912800	9930030	9930000	9930000
GRUPPO TERMICO RACING 2004 C/TESTA SCOMPOSTA (GHISA)	RACING CYLINDER KITS BIG BORE without head (CAST IRON)	CYLINDRE COMPLET RACING 2004 AVEC CULASSE DÉCOMPOSÉE (FONTE)		9921160			
GRUPPO TRASFORMAZIONE DA ARIA AD ACQUA (GHISA)	CYLINDER KIT Conversion AC to LC (CAST IRON)	GROUPE TRANSFORMATION DE L'AIR À L'EAU (FONTE)			9911210		
GRUPPO TERMICO TPR IN ALLUMINIO Ø 47,6 Spinotto Ø 10	CYLINDER KIT TPR ALLUMINIUM Ø 47,6 Pin Ø 10	CYLINDRE COMPLET TPR EN ALUMINIUM Ø 47,6 Axe de Piston Ø 10		9928480	9921630	9921640	9921640
GRUPPO TERMICO TPR IN ALLUMINIO Ø 47,6 Spinotto Ø 12	CYLINDER KIT TPR ALLUMINIUM Ø 47,6 Pin Ø 12	CYLINDRE COMPLET TPR EN ALUMINIUM Ø 47,6 Axe de Piston Ø 12		9928550			
KIT ASPIRAZIONE COMPLETO MIKUNI TPR 360	COMPLETE INLET KIT MIKUNI TM 24 TPR 360	KIT ASPIRATION COMPLET MIKUNI TM 24 TPR 360		9930830	9930830		
KIT ASPIRAZIONE COMPLETO OKO 28	COMPLETE INLET KIT OKO 28 TPR 360	KIT ASPIRATION COMPLET OKO 28 TPR 360		9931710	9931710		
MAXI KIT 77 cc ALESAGGIO Ø 50 CORSA STD	MAXI KIT 77 cc Bore Ø 50 Standard stroke	MAXI KIT 77 cc ALÉSAGE Ø 50 COURSE STD		9926580			
MAXI KIT 86 cc ALESAGGIO Ø 50 CORSA 44 mm	MAXI KIT 86 cc Bore Ø 50 stroke 44 mm	MAXI KIT 86 cc ALÉSAGE Ø 50 COURSE 44 mm		9926560			
RAPPORTO ALLUNGATO secondario	SHAFT/GEARS	RAPPORT ALLONGÉ secondaire		990875P		990875P	990875P
SERIE MOLLE CONTRASTO	VARIATOR SPRINGS SET	VARIATEUR RESSORT SET		9925620	9925620	9925620	9925620
SERIE MOLLE FRIZIONE	CLUTCH SPRINGS SET	RESSORT EMBRAYAGE SET		9908240 9912740	9908240 9912740	9908240 9912740	9908240 9912740
SCARICO NARDÒ 2 omologato	EXHAUST NARDÒ 2 Approved	ÉCHAPPEMENT NARDÒ 2 homologué		9931440	9931440	9931450	9931450
SCARICO TPR GP omologato	EXHAUST TPR GP Approved	ÉCHAPPEMENT TPR GP homologué		9930140			
VALVOLA LAMELLARE TPR	REED VALVE TPR	CLAPET À LAMELLES TPR		9931620	9931620		
VARIOTOP TPR c/cinghia	VARIOTOP TPR with belt	VARIOTOP TPR avec courroie		9931670	9931690	9931670	9931670
VARIOTOP TPR s/cinghia	VARIOTOP TPR with spring	VARIOTOP TPR avec ressort		9931650	9931650	9931650	9931650

MBK	MBK	MBK	MBK	MBK	MBK	MBK	MBK	MBK	MBK	MBK	MBK	
BOOSTER	BOOSTER EURO 2	BOOSTER NG	BOOSTER NG	BOOSTER ROCKET	BOOSTER SPIRIT	BOOSTER SPIRIT	BOOSTER SPIRIT	BOOSTER SPIRIT	BOOSTER SPIRIT	BOOSTER SPIRIT EURO2	BOOSTER TRACK	BOOSTER X IE
92-94	04-04	95-03	03-03	97-98	96-98	99-00	00-00	03-03	03-03	96-98	08-08	
50cc 2T AC	50cc 2T AC	50cc 2T AC	50cc 2T AC	50cc 2T AC	50cc 2T AC	50cc 2T AC	50cc 2T AC	50cc 2T AC	50cc 2T AC	50cc 2T AC	50cc 2T AC	50cc 4T-3V LC
CW	CW	CW	CW	CW	CW	CW	CW	CW	CW	CW	CW	15P1
9927900	9927900	9927900	9927900	9927900	9927900	9927900	9927900	9927900	9927900	9927900	9927900	
	9921790		9921790					9921790	9921790			
9923030	9923030	9923030	9923030	9923030	9923030	9923030	9923030	9923030	9923030	9923030	9923030	
9930300	9930300	9930300	9930300	9930300	9930300	9930300	9930300	9930300	9930300	9930300	9930300	
9929190	9929190	9929190	9929190	9929190	9929190	9929190	9929190	9929190	9929190	9929190	9929190	
9927450	9927450	9927450	9927450	9927450	9927450	9927450	9927450	9927450	9927450	9927450	9927450	
9930000	9930000	9930000	9930000	9930000	9930000	9930000	9930000	9930000	9930000	9930000	9930000	
9921640	9921640	9921640	9921640	9921640	9921640	9921640	9921640	9921640	9921640	9921640	9921640	9926330
990875P	990875P	990875P	990875P	990875P	990875P	990875P	990875P	990875P	990875P	990875P	990875P	
9925620	9925620	9925620	9925620	9925620	9925620	9925620	9925620	9925620	9925620	9925620	9925620	9925620
9908240 9912740	9908240 9912740	9908240 9912740	9908240 9912740	9908240	9908240 9912740	9908240 9912740	9908240 9912740	9908240 9912740	9908240 9912740	9908240 9912740	9908240	9912740
9931450		9931450		9931450	9931450	9931450	9931450				9931450	
9931670	9931670	9931670	9931670	9931670	9931670	9931670	9931670	9931670	9931670	9931670	9931670	
9931650	9931650	9931650	9931650	9931650	9931650	9931650	9931650	9931650	9931650	9931650	9931650	9926130

SCOOTER 50cc RACING

SCOOTER 50cc RACING

TOP
- performances -



MBK	MBK	MBK	MBK
EVOLIS	FIZZ	FLIPPER	FLIPPER EURO 2
92-95	94-95	98-04	03-03
50cc 2T AC	50cc 2T AC	50cc 2T AC	50cc 2T AC
CY	CY	MY	MY

IT	EN	FR				
ALBERO MOTORE TPR CORSA STD Spinotto Ø 10	CRANKSHAFT TPR Standard stroke pin Ø10	VILEBREQUIN TPR COURSE STD Axe de piston Ø 10		9925910	9925910	9925910
ALBERO MOTORE TPR CORSA STD Spinotto Ø 12	CRANKSHAFT TPR Standard stroke pin Ø12	VILEBREQUIN TPR COURSE STD Axe de piston Ø 12		9928320	9928320	9928320
CENTRALINA RACING	RACING CDI	Unité de contrôle RACING				9921790
CONVERTITORE DI COPPIA	REAR VARIATOR PULLEY ASSY	POULIE SECONDAIRE		9923030	9923030	9923030
COPERCHIO INGRANAGGI	GEAR COVER	COUVERCLE ENGRENAGES				9930300
CUSCINETTI DI BANCO TPR CARBONITRURATI Serie	BEARINGS TPR Carbonitrided Series	PALIERI DE VILEBREQUIN TPR CARBONITRURÉS Jeu		9929190	9929190	9929190
FRIZIONE TPR GP REGOLABILE Patented	CLUTCH TPR GP Adjustable Patented	EMBRAYAGE TPR GP RÉGLABLE Patented				9927450
GRUPPO TERMICO RACING MAGGIORATO C/TESTA (GHISA)	RACING CYLINDER KITS BIG BORE with head (CAST IRON)	CYLINDRE COMPLET RACING MAJORÉ AVEC CULASSE (FONTE)		9930030	9930030	9930030
GRUPPO TERMICO RACING 2004 C/TESTA SCOMPOSTA (GHISA)	RACING CYLINDER KITS BIG BORE without head (CAST IRON)	CYLINDRE COMPLET RACING 2004 AVEC CULASSE DÉCOMPOSÉE (FONTE)				
GRUPPO TRASFORMAZIONE DA ARIA AD ACQUA (GHISA)	CYLINDER KIT Conversion AC to LC (CAST IRON)	GROUPE TRANSFORMATION DE L'AIR À L'EAU (FONTE)		9911210	9911210	9911210
GRUPPO TERMICO TPR IN ALLUMINIO Ø 47,6 Spinotto Ø 10	CYLINDER KIT TPR ALLUMINIUM Ø 47,6 Pin Ø 10	CYLINDRE COMPLET TPR EN ALUMINIUM Ø 47,6 Axe de Piston Ø 10		9921630	9921630	9921630
GRUPPO TERMICO TPR IN ALLUMINIO Ø 47,6 Spinotto Ø 12	CYLINDER KIT TPR ALLUMINIUM Ø 47,6 Pin Ø 12	CYLINDRE COMPLET TPR EN ALUMINIUM Ø 47,6 Axe de Piston Ø 12				
KIT ASPIRAZIONE COMPLETO MIKUNI TPR 360	COMPLETE INLET KIT MIKUNI TM 24 TPR 360	KIT ASPIRATION COMPLET MIKUNI TM 24 TPR 360		9930830	9930830	9930830
KIT ASPIRAZIONE COMPLETO OKO 28	COMPLETE INLET KIT OKO 28 TPR 360	KIT ASPIRATION COMPLET OKO 28 TPR 360		9931710	9931710	9931710
MAXI KIT 77 cc ALESAGGIO Ø 50 CORSA STD	MAXI KIT 77 cc Bore Ø 50 Standard stroke	MAXI KIT 77 cc ALÉSAGE Ø 50 COURSE STD				
MAXI KIT 86 cc ALESAGGIO Ø 50 CORSA 44 mm	MAXI KIT 86 cc Bore Ø 50 stroke 44 mm	MAXI KIT 86 cc ALÉSAGE Ø 50 COURSE 44 mm				
RAPPORTO ALLUNGATO secondario	SHAFT/GEARS	RAPPORT ALLONGÉ secondaire				
SERIE MOLLE CONTRASTO	VARIATOR SPRINGS SET	VARIATEUR RESSORT SET		9925620	9925620	9925620
SERIE MOLLE FRIZIONE	CLUTCH SPRINGS SET	RESSORT EMBRAYAGE SET				9908240 9912740
SCARICO NARDÒ 2 omologato	EXHAUST NARDÒ 2 Approved	ÉCHAPPEMENT NARDÒ 2 homologué		9931440	9931440	9931440
SCARICO TPR GP omologato	EXHAUST TPR GP Approved	ÉCHAPPEMENT TPR GP homologué				
VALVOLA LAMELLARE TPR	REED VALVE TPR	CLAPET À LAMELLES TPR		9931620	9931620	9931620
VARIOTOP TPR c/cinghia	VARIOTOP TPR with belt	VARIOTOP TPR avec courroie		9931690	9931690	9931670
VARIOTOP TPR s/cinghia	VARIOTOP TPR with spring	VARIOTOP TPR avec ressort		9931650	9931650	9931650

MBK	MBK	MBK	MBK	MBK	MBK	MBK	MBK	MBK	MBK	MBK	MOTRON
FORTE	MACH G	MACH G LC	NITRO	NITRO EURO 2	OVETTO	OVETTO 4T	OVETTO EURO 2	SORRISO	STUNT	TARGET	STING
94-96	02-04	02-04	97-04	03-03	97-04	09-11	02-02	95-96	00-02	91-95	95-96
50cc 2T AC	50cc 2T AC	50cc 2T LC	50cc 2T LC	50cc 2T LC	50cc 2T AC	50cc 4T-3V LC	50cc 2T AC	50cc 2T AC	50cc 2T AC	50cc 2T AC	50cc 2T AC
CY	MY	MA	MA	MA	MY	5C3	MY	Tipo CW	CW	Tipo CW	CY
9925910	9925910	9925910	9925910	9925910	9925910		9925910		9927900		
9928320	9928320	9928320	9928320	9928320	9928320		9928320				
	9921790	9921790		9921790			9921790				
9923030	9923030	9923030	9923030	9923030	9923030		9923030		9923030		
	9930300	9930300	9930300	9930300	9930300		9930300		9930300		
9929190	9929190	9929190	9929190	9929190	9929190		9929190		9929190		9929190
	9927450	9927450	9927450	9927450	9927450		9927450	9927450	9927450	9927450	
9930030	9930030	9912800	9912800	9912800	9930030		9930030		9930000		9930030
		9921160	9921160	9921160							
9911210	9911210				9911210		9911210				
9921630	9921630	9928480	9928480	9928480	9921630	9926330	9921630		9921640		
		9928550	9928550	9928550							
9930830	9930830	9930830	9930830	9930830	9930830		9930830				9930830
9931710	9931710	9931710	9931710	9931710	9931710		9931710				9931710
		9926580	9926580	9926580							
		9926560	9926560	9926560							
	990875P	990875P	990875P	990875P	990875P		990875P		990875P		
9925620	9925620	9925620	9925620	9925620	9925620	9925620	9925620		9925620		9925620
	9908240 9912740	9908240 9912740	9908240 9912740	9908240 9912740	9908240 9912740	9912740	9908240 9912740	9908240	9908240 9912740	9908240	
9931440	9931440	9931440	9931440	9931440	9931440		9931440		9931450		
		9930140	9930140	9930140							
9931620	9931620	9931620	9931620	9931620	9931620		9931620				
9931690	9931670	9931670	9931670	9931670	9931670		9931670		9931670		
9931650	9931650	9931650	9931650	9931650	9931650	9926130	9931650		9931650		

SCOOTER 50cc
RACING

SCOOTER 50cc RACING

TOP
- performances -



MOTRON	MOTRON	PEUGEOT	PEUGEOT
SYNCR0	THUNDER	BUXY	BUXY RS
98-00	95-98	90-02	90-02
50cc 2T AC	50cc 2T AC	50cc 2T AC	50cc 2T AC
MY	MY	Motore Peugeot	Motore Peugeot

IT	EN	FR				
ALBERO MOTORE TPR CORSA STD Spinotto Ø 10	CRANKSHAFT TPR Standard stroke pin Ø10	VILEBREQUIN TPR COURSE STD Axe de piston Ø 10		9925910	9925910	
ALBERO MOTORE TPR CORSA STD Spinotto Ø 12	CRANKSHAFT TPR Standard stroke pin Ø12	VILEBREQUIN TPR COURSE STD Axe de piston Ø 12		9928320	9928320	
CENTRALINA RACING	RACING CDI	Unité de contrôle RACING				
CONVERTITORE DI COPPIA	REAR VARIATOR PULLEY ASSY	POULIE SECONDAIRE		9923030	9923030	
COPERCHIO INGRANAGGI	GEAR COVER	COUVERCLE ENGRENAGES		9930300	9930300	
CUSCINETTI DI BANCO TPR CARBONITRURATI Serie	BEARINGS TPR Carbonitrided Series	PALIERI DE VILEBREQUIN TPR CARBONITRURÉS Jeu		9929190	9929190	
FRIZIONE TPR GP REGOLABILE Patented	CLUTCH TPR GP Adjustable Patented	EMBRAYAGE TPR GP RÉGLABLE Patented		9927450	9927450	
GRUPPO TERMICO RACING MAGGIORATO C/TESTA (GHISA)	RACING CYLINDER KITS BIG BORE with head (CAST IRON)	CYLINDRE COMPLET RACING MAJORÉ AVEC CULASSE (FONTE)		9930030	9930030	
GRUPPO TERMICO RACING 2004 C/TESTA SCOMPOSTA (GHISA)	RACING CYLINDER KITS BIG BORE without head (CAST IRON)	CYLINDRE COMPLET RACING 2004 AVEC CULASSE DÉCOMPOSÉE (FONTE)				
GRUPPO TRASFORMAZIONE DA ARIA AD ACQUA (GHISA)	CYLINDER KIT Conversion AC to LC (CAST IRON)	GROUPE TRANSFORMATION DE L'AIR À L'EAU (FONTE)		9911210	9911210	
GRUPPO TERMICO TPR IN ALLUMINIO Ø 47,6 Spinotto Ø 10	CYLINDER KIT TPR ALLUMINIUM Ø 47,6 Pin Ø 10	CYLINDRE COMPLET TPR EN ALUMINIUM Ø 47,6 Axe de Piston Ø 10		9921630	9921630	
GRUPPO TERMICO TPR IN ALLUMINIO Ø 47,6 Spinotto Ø 12	CYLINDER KIT TPR ALLUMINIUM Ø 47,6 Pin Ø 12	CYLINDRE COMPLET TPR EN ALUMINIUM Ø 47,6 Axe de Piston Ø 12				
KIT ASPIRAZIONE COMPLETO MIKUNI TPR 360	COMPLETE INLET KIT MIKUNI TM 24 TPR 360	KIT ASPIRATION COMPLET MIKUNI TM 24 TPR 360		9930830	9930830	
KIT ASPIRAZIONE COMPLETO OKO 28	COMPLETE INLET KIT OKO 28 TPR 360	KIT ASPIRATION COMPLET OKO 28 TPR 360		9931710	9931710	
MAXI KIT 77 cc ALESAGGIO Ø 50 CORSA STD	MAXI KIT 77 cc Bore Ø 50 Standard stroke	MAXI KIT 77 cc ALÉSAGE Ø 50 COURSE STD				
MAXI KIT 86 cc ALESAGGIO Ø 50 CORSA 44 mm	MAXI KIT 86 cc Bore Ø 50 stroke 44 mm	MAXI KIT 86 cc ALÉSAGE Ø 50 COURSE 44 mm				
RAPPORTO ALLUNGATO secondario	SHAFT/GEARS	RAPPORT ALLONGÉ secondaire		990875P	990875P	
SERIE MOLLE CONTRASTO	VARIATOR SPRINGS SET	VARIATEUR RESSORT SET		9925620	9925620	
SERIE MOLLE FRIZIONE	CLUTCH SPRINGS SET	RESSORT EMBRAYAGE SET		9908240	9908240	
SCARICO NARDÒ 2 omologato	EXHAUST NARDÒ 2 Approved	ÉCHAPPEMENT NARDÒ 2 homologué				
SCARICO TPR GP omologato	EXHAUST TPR GP Approved	ÉCHAPPEMENT TPR GP homologué				
VALVOLA LAMELLARE TPR	REED VALVE TPR	CLAPET À LAMELLES TPR		9931620	9931620	
VARIOTOP TPR c/cinghia	VARIOTOP TPR with belt	VARIOTOP TPR avec courroie		9931670	9931670	9910780 9910780
VARIOTOP TPR s/cinghia	VARIOTOP TPR with spring	VARIOTOP TPR avec ressort		9931650	9931650	

PEUGEOT	PGO	PIAGGIO	PIAGGIO	PIAGGIO	PIAGGIO	PIAGGIO	PIAGGIO	PIAGGIO	PIAGGIO	PIAGGIO	PIAGGIO
SPEEDAKE	BIG MAX	DIESIS	FLY 2T	FLY 2T	FLY 4T	FLY 4T & 25-30 KM/H	FLY 4T 4V	FLY 4T MOTO-RE CHN	FREE	FREE DELIVERY	FREE FL
90-02	95-97	01-01	05-07	10-11	05-07	08-11	12-13	06-07	92-94	00-01	95-02
50cc 2T AC	50cc 2T AC	50cc 2T AC	50cc 2T AC	50cc 2T AC	50cc 4T AC	50cc 4T AC	50cc 4T-4V AC	50cc 4T AC	50cc 2T AC	50cc 2T AC	50cc 2T AC
Motore Peugeot	Tipo MY	Motore Piaggio	Motore Piaggio	Motore Piaggio	Motore Piaggio	Motore Piaggio	Motore Piaggio	Motore Piaggio	Motore Piaggio	Motore Piaggio	Motore Piaggio
		9926180	9926180	9926180					9926180	9926180	9926180
		9923150	9923150	9923150	9923150	9923150		9923150	9923150	9923150	9923150
	9929190	9929200	9929200	9929200					9929200	9929200	9929200
		9928340	9928340	9928340	9928340	9928340	9928340	9928340	9928340	9928340	9928340
	9930030	9930060	9930060	9930060					9930060	9930060	9930060
	9921630										
		9921550	9921550	9921550					9921550	9921550	9921550
	9930830	9930870	9930870	9930870					9930870	9930870	9930870
	9931710	9931730	9931730	9931730					9931730	9931730	9931730
	9925620	9925630	9925630	9925630	9925630	9925630		9925630	9925630	9925630	9925630
		9931460	9931460	9931460					9931460	9931460	9931460
		9931640	9931640	9931640					9931640	9931640	9931640
9910780		9931300									
		9927610	9927610	9927610	9927610	9927610	9927610	9927610	9927610	9927610	9927610

SCOOTER 50cc RACING

SCOOTER 50cc RACING

TOP
- performances -



PIAGGIO	PIAGGIO	PIAGGIO	PIAGGIO
LIBERTY	LIBERTY 2T	LIBERTY 2T	LIBERTY 2T PTT EU2
97-05	06-06	07-08	04-05
50cc 2T AC	50cc 2T AC	50cc 2T AC	50cc 2T AC
Motore Piaggio	Motore Piaggio	Motore Piaggio	Motore Piaggio

IT	EN	FR				
ALBERO MOTORE TPR CORSA STD Spinotto Ø 10	CRANKSHAFT TPR Standard stroke pin Ø10	VILEBREQUIN TPR COURSE STD Axe de piston Ø 10				
ALBERO MOTORE TPR CORSA STD Spinotto Ø 12	CRANKSHAFT TPR Standard stroke pin Ø12	VILEBREQUIN TPR COURSE STD Axe de piston Ø 12		9926180	9926180	9926180
CENTRALINA RACING	RACING CDI	Unité de contrôle RACING				
CONVERTITORE DI COPPIA	REAR VARIATOR PULLEY ASSY	POULIE SECONDAIRE		9923150	9923150	9923150
COPERCHIO INGRANAGGI	GEAR COVER	COUVERCLE ENGRENAGES				
CUSCINETTI DI BANCO TPR CARBONITRURATI Serie	BEARINGS TPR Carbonitrided Series	PALIERI DE VILEBREQUIN TPR CARBONITRURÉS Jeu		9929200	9929200	9929200
FRIZIONE TPR GP REGOLABILE Patented	CLUTCH TPR GP Adjustable Patented	EMBRAYAGE TPR GP RÉGLABLE Patented		9928340	9928340	9928340
GRUPPO TERMICO RACING MAGGIORATO C/TESTA (GHISA)	RACING CYLINDER KITS BIG BORE with head (CAST IRON)	CYLINDRE COMPLET RACING MAJORÉ AVEC CULASSE (FONTE)		9930060	9930060	9930060
GRUPPO TERMICO RACING 2004 C/TESTA SCOMPOSTA (GHISA)	RACING CYLINDER KITS BIG BORE without head (CAST IRON)	CYLINDRE COMPLET RACING 2004 AVEC CULASSE DÉCOMPOSÉE (FONTE)				
GRUPPO TRASFORMAZIONE DA ARIA AD ACQUA (GHISA)	CYLINDER KIT Conversion AC to LC (CAST IRON)	GROUPE TRANSFORMATION DE L'AIR À L'EAU (FONTE)				
GRUPPO TERMICO TPR IN ALLUMINIO Ø 47,6 Spinotto Ø 10	CYLINDER KIT TPR ALLUMINIUM Ø 47,6 Pin Ø 10	CYLINDRE COMPLET TPR EN ALUMINIUM Ø 47,6 Axe de Piston Ø 10				
GRUPPO TERMICO TPR IN ALLUMINIO Ø 47,6 Spinotto Ø 12	CYLINDER KIT TPR ALLUMINIUM Ø 47,6 Pin Ø 12	CYLINDRE COMPLET TPR EN ALUMINIUM Ø 47,6 Axe de Piston Ø 12		9921550	9921550	9921550
KIT ASPIRAZIONE COMPLETO MIKUNI TPR 360	COMPLETE INLET KIT MIKUNI TM 24 TPR 360	KIT ASPIRATION COMPLET MIKUNI TM 24 TPR 360		9930870	9930870	9930870
KIT ASPIRAZIONE COMPLETO OKO 28	COMPLETE INLET KIT OKO 28 TPR 360	KIT ASPIRATION COMPLET OKO 28 TPR 360		9931730	9931730	9931730
MAXI KIT 77 cc ALESAGGIO Ø 50 CORSA STD	MAXI KIT 77 cc Bore Ø 50 Standard stroke	MAXI KIT 77 cc ALÉSAGE Ø 50 COURSE STD				
MAXI KIT 86 cc ALESAGGIO Ø 50 CORSA 44 mm	MAXI KIT 86 cc Bore Ø 50 stroke 44 mm	MAXI KIT 86 cc ALÉSAGE Ø 50 COURSE 44 mm				
RAPPORTO ALLUNGATO secondario	SHAFT/GEARS	RAPPORT ALLONGÉ secondaire				
SERIE MOLLE CONTRASTO	VARIATOR SPRINGS SET	VARIATEUR RESSORT SET		9925630	9925630	9925630
SERIE MOLLE FRIZIONE	CLUTCH SPRINGS SET	RESSORT EMBRAYAGE SET				
SCARICO NARDÒ 2 omologato	EXHAUST NARDÒ 2 Approved	ÉCHAPPEMENT NARDÒ 2 homologué		9931460	9931460	9931460
SCARICO TPR GP omologato	EXHAUST TPR GP Approved	ÉCHAPPEMENT TPR GP homologué				
VALVOLA LAMELLARE TPR	REED VALVE TPR	CLAPET À LAMELLES TPR		9931640	9931640	9931640
VARIOTOP TPR c/cinghia	VARIOTOP TPR with belt	VARIOTOP TPR avec courroie				
VARIOTOP TPR s/cinghia	VARIOTOP TPR with spring	VARIOTOP TPR avec ressort		9927610	9927610	9927610

PIAGGIO	PIAGGIO	PIAGGIO	PIAGGIO	PIAGGIO	PIAGGIO	PIAGGIO	PIAGGIO	PIAGGIO	PIAGGIO	PIAGGIO	PIAGGIO
LIBERTY 2T RST	LIBERTY 2T SPORT	LIBERTY 2T SPORT	LIBERTY 4T	LIBERTY 4T	LIBERTY 4T 3V IE	LIBERTY 4T 3V IE E4	LIBERTY 4T DELIVERY - SINGLE	LIBERTY 4T DELIVERY TNT	LIBERTY 4T IGET CORPO-RATE E4	LIBERTY 4T PTT - DOUBLE - NEXIVE	LIBERTY 4T RST
04-04	06-06	07-08	00-02	05-08	15-17	17-18	10-14	09-09	18-20	09-17	04-04
50cc 2T AC	50cc 2T AC	50cc 2T AC	50cc 4T AC	50cc 4T AC	50cc 4T-3V AC	50cc 4T-3V AC	50cc 4T AC	50cc 4T AC	50cc 4T-3V AC	50cc 4T AC	50cc 4T AC
Motore Piaggio	Motore Piaggio	Motore Piaggio	Motore Piaggio	Motore Piaggio	Motore Piaggio	Motore Piaggio	Motore Piaggio	Motore Piaggio	Motore Piaggio	Motore Piaggio	Motore Piaggio
9926180	9926180	9926180									
9923150	9923150	9923150	9923150	9923150			9923150	9923150		9923150	9923150
9929200	9929200	9929200									
9928340	9928340	9928340	9928340	9928340	9928340	9928340	9928340	9928340		9928340	9928340
9930060	9930060	9930060									
9921550	9921550	9921550									
9930870	9930870	9930870									
9931730	9931730	9931730									
9925630	9925630	9925630	9925630	9925630	9925630	9925630	9925630	9925630		9925630	9925630
9931460	9931460	9931460									
9931640	9931640	9931640									
9927610	9927610	9927610	9927610		9927610	9927610	9927610	9927610	9927610	9927610	9927610

SCOOTER 50cc RACING

SCOOTER 50cc RACING

TOP
- performances -



PIAGGIO	PIAGGIO	PIAGGIO	PIAGGIO
LIBERTY 4T SPORT	LIBERTY 4T SPORT	LIBERTY IGET 4T 3V IE E4 EMEA	LIBERTY MOC 2T & ELLE
06-06	07-08	17-19	09-13
50cc 4T AC	50cc 4T AC	50cc 4T-3V AC	50cc 2T AC
Motore Piaggio	Motore Piaggio	Motore Piaggio	Motore Piaggio

IT	EN	FR				
ALBERO MOTORE TPR CORSA STD Spinotto Ø 10	CRANKSHAFT TPR Standard stroke pin Ø10	VILEBREQUIN TPR COURSE STD Axe de piston Ø 10				
ALBERO MOTORE TPR CORSA STD Spinotto Ø 12	CRANKSHAFT TPR Standard stroke pin Ø12	VILEBREQUIN TPR COURSE STD Axe de piston Ø 12				9926180
CENTRALINA RACING	RACING CDI	Unité de contrôle RACING				
CONVERTITORE DI COPPIA	REAR VARIATOR PULLEY ASSY	POULIE SECONDAIRE		9923150	9923150	9923150
COPERCHIO INGRANAGGI	GEAR COVER	COUVERCLE ENGRENAGES				
CUSCINETTI DI BANCO TPR CARBONITRURATI Serie	BEARINGS TPR Carbonitrided Series	PALIERI DE VILEBREQUIN TPR CARBONITRURÉS Jeu				9929200
FRIZIONE TPR GP REGOLABILE Patented	CLUTCH TPR GP Adjustable Patented	EMBAYAGE TPR GP RÉGLABLE Patented		9928340	9928340	9928340
GRUPPO TERMICO RACING MAGGIORATO C/TESTA (GHISA)	RACING CYLINDER KITS BIG BORE with head (CAST IRON)	CYLINDRE COMPLET RACING MAJORÉ AVEC CULASSE (FONTE)				9930060
GRUPPO TERMICO RACING 2004 C/TESTA SCOMPOSTA (GHISA)	RACING CYLINDER KITS BIG BORE without head (CAST IRON)	CYLINDRE COMPLET RACING 2004 AVEC CULASSE DÉCOMPOSÉE (FONTE)				
GRUPPO TRASFORMAZIONE DA ARIA AD ACQUA (GHISA)	CYLINDER KIT Conversion AC to LC (CAST IRON)	GROUPE TRANSFORMATION DE L'AIR À L'EAU (FONTE)				
GRUPPO TERMICO TPR IN ALLUMINIO Ø 47,6 Spinotto Ø 10	CYLINDER KIT TPR ALLUMINIUM Ø 47,6 Pin Ø 10	CYLINDRE COMPLET TPR EN ALUMINIUM Ø 47,6 Axe de Piston Ø 10				
GRUPPO TERMICO TPR IN ALLUMINIO Ø 47,6 Spinotto Ø 12	CYLINDER KIT TPR ALLUMINIUM Ø 47,6 Pin Ø 12	CYLINDRE COMPLET TPR EN ALUMINIUM Ø 47,6 Axe de Piston Ø 12				9921550
KIT ASPIRAZIONE COMPLETO MIKUNI TPR 360	COMPLETE INLET KIT MIKUNI TM 24 TPR 360	KIT ASPIRATION COMPLET MIKUNI TM 24 TPR 360				9930870
KIT ASPIRAZIONE COMPLETO OKO 28	COMPLETE INLET KIT OKO 28 TPR 360	KIT ASPIRATION COMPLET OKO 28 TPR 360				9931730
MAXI KIT 77 cc ALESAGGIO Ø 50 CORSA STD	MAXI KIT 77 cc Bore Ø 50 Standard stroke	MAXI KIT 77 cc ALÉSAGE Ø 50 COURSE STD				
MAXI KIT 86 cc ALESAGGIO Ø 50 CORSA 44 mm	MAXI KIT 86 cc Bore Ø 50 stroke 44 mm	MAXI KIT 86 cc ALÉSAGE Ø 50 COURSE 44 mm				
RAPPORTO ALLUNGATO secondario	SHAFT/GEARS	RAPPORT ALLONGÉ secondaire				
SERIE MOLLE CONTRASTO	VARIATOR SPRINGS SET	VARIATEUR RESSORT SET		9925630	9925630	9925630
SERIE MOLLE FRIZIONE	CLUTCH SPRINGS SET	RESSORT EMBRAYAGE SET				
SCARICO NARDÒ 2 omologato	EXHAUST NARDÒ 2 Approved	ÉCHAPPEMENT NARDÒ 2 homologué				9931460
SCARICO TPR GP omologato	EXHAUST TPR GP Approved	ÉCHAPPEMENT TPR GP homologué				
VALVOLA LAMELLARE TPR	REED VALVE TPR	CLAPET À LAMELLES TPR				9931640
VARIOTOP TPR c/cinghia	VARIOTOP TPR with belt	VARIOTOP TPR avec courroie				
VARIOTOP TPR s/cinghia	VARIOTOP TPR with spring	VARIOTOP TPR avec ressort			9927610	9927610

PIAGGIO	PIAGGIO	PIAGGIO	PIAGGIO	PIAGGIO	PIAGGIO	PIAGGIO	PIAGGIO	PIAGGIO	PIAGGIO	PIAGGIO	PIAGGIO
LIBERTY MOC 4T & ELLE	NRG	NRG EXTREME LC	NRG MC3	NRG POWER DD	NRG POWER DD	NRG POWER DD	NRG POWER DD SERIE SPECIALE	NRG POWER DT	NRG POWER DT	NRG POWER DT SERIE SPECIALE	NRG POWER PUREJET
09-16	94-96	99-00	01-04	05-05	06-06	07-17	07-12	06-06	07-15	07-08	04-05
50cc 4T AC	50cc 2T LC	50cc 2T LC	50cc 2T LC	50cc 2T LC	50cc 2T LC	50cc 2T LC	50cc 2T LC	50cc 2T AC	50cc 2T AC	50cc 2T AC	50cc 2T-IE LC
Motore Piaggio	Motore Piaggio	Motore Piaggio	Motore Piaggio	Motore Piaggio	Motore Piaggio	Motore Piaggio	Motore Piaggio	Motore Piaggio	Motore Piaggio	Motore Piaggio	Motore Piaggio
	9926180	9926180	9926180	9926180	9926180	9926180	9926180	9926180	9926180	9926180	
9923150	9923150	9923150	9923150	9923150	9923150	9923150	9923150	9923150	9923150	9923150	9923150
	9929200	9929200	9929200	9929200	9929200	9929200	9929200	9929200	9929200	9929200	9929200
9928340	9928340	9928340	9928340	9928340	9928340	9928340	9928340	9928340	9928340	9928340	9928340
	9920590	9920590	9920590	9920590	9920590	9920590	9920590	9930060	9930060	9930060	
	9928520	9928520	9928520	9928520	9928520	9928520	9928520	9921550	9921550	9921550	
	9930870	9930870	9930870	9930870	9930870	9930870	9930870	9930870	9930870	9930870	9930870
	9931730	9931730	9931730	9931730	9931730	9931730	9931730	9931730	9931730	9931730	9931730
	9928390	9928390	9928390	9928390	9928390	9928390	9928390				
	9928440	9928440	9928440	9928440	9928440	9928440	9928440				
9925630	9925630	9925630	9925630	9925630	9925630	9925630	9925630	9925630	9925630	9925630	9925630
	9931460	9931460	9931460	9931460	9931460	9931460	9931460	9931460	9931460	9931460	9931460
	9930160	9930160	9930160	9930160	9930160	9930160	9930160				
	9931640	9931640	9931640	9931640	9931640	9931640	9931640	9931640	9931640	9931640	9931640
			9931300	9931300	9931300	9931300	9931300	9931300	9931300	9931300	9931300
9927610	9927610	9927610	9927610	9927610	9927610	9927610	9927610	9927610	9927610	9927610	9927610

SCOOTER 50cc RACING

SCOOTER 50cc RACING

TOP
- performances -



PIAGGIO	PIAGGIO	PIAGGIO	PIAGGIO
NRG POWER PUREJET	NRG POWER PUREJET	NRG POWER PUREJET	NRG PUREJET
06-06	07-09	10-11	02-04
50cc 2T-IE LC	50cc 2T-IE LC	50cc 2T-IE LC	50cc 2T-IE LC
Motore Piaggio	Motore Piaggio	Motore Piaggio	Motore Piaggio

IT	EN	FR				
ALBERO MOTORE TPR CORSA STD Spinotto Ø 10	CRANKSHAFT TPR Standard stroke pin Ø10	VILEBREQUIN TPR COURSE STD Axe de piston Ø 10				
ALBERO MOTORE TPR CORSA STD Spinotto Ø 12	CRANKSHAFT TPR Standard stroke pin Ø12	VILEBREQUIN TPR COURSE STD Axe de piston Ø 12				
CENTRALINA RACING	RACING CDI	Unité de contrôle RACING				
CONVERTITORE DI COPPIA	REAR VARIATOR PULLEY ASSY	POULIE SECONDAIRE		9923150	9923150	9923150
COPERCHIO INGRANAGGI	GEAR COVER	COUVERCLE ENGRENAGES				
CUSCINETTI DI BANCO TPR CARBONITRURATI Serie	BEARINGS TPR Carbonitrided Series	PALIERI DE VILEBREQUIN TPR CARBONITRURÉS Jeu		9929200	9929200	9929200
FRIZIONE TPR GP REGOLABILE Patented	CLUTCH TPR GP Adjustable Patented	EMBAYAGE TPR GP RÉGLABLE Patented		9928340	9928340	9928340
GRUPPO TERMICO RACING MAGGIORATO C/TESTA (GHISA)	RACING CYLINDER KITS BIG BORE with head (CAST IRON)	CYLINDRE COMPLET RACING MAJORÉ AVEC CULASSE (FONTE)				
GRUPPO TERMICO RACING 2004 C/TESTA SCOMPOSTA (GHISA)	RACING CYLINDER KITS BIG BORE without head (CAST IRON)	CYLINDRE COMPLET RACING 2004 AVEC CULASSE DÉCOMPOSÉE (FONTE)				
GRUPPO TRASFORMAZIONE DA ARIA AD ACQUA (GHISA)	CYLINDER KIT Conversion AC to LC (CAST IRON)	GROUPE TRANSFORMATION DE L'AIR À L'EAU (FONTE)				
GRUPPO TERMICO TPR IN ALLUMINIO Ø 47,6 Spinotto Ø 10	CYLINDER KIT TPR ALLUMINIUM Ø 47,6 Pin Ø 10	CYLINDRE COMPLET TPR EN ALUMINIUM Ø 47,6 Axe de Piston Ø 10				
GRUPPO TERMICO TPR IN ALLUMINIO Ø 47,6 Spinotto Ø 12	CYLINDER KIT TPR ALLUMINIUM Ø 47,6 Pin Ø 12	CYLINDRE COMPLET TPR EN ALUMINIUM Ø 47,6 Axe de Piston Ø 12				
KIT ASPIRAZIONE COMPLETO MIKUNI TPR 360	COMPLETE INLET KIT MIKUNI TM 24 TPR 360	KIT ASPIRATION COMPLET MIKUNI TM 24 TPR 360		9930870	9930870	9930870
KIT ASPIRAZIONE COMPLETO OKO 28	COMPLETE INLET KIT OKO 28 TPR 360	KIT ASPIRATION COMPLET OKO 28 TPR 360		9931730	9931730	9931730
MAXI KIT 77 cc ALESAGGIO Ø 50 CORSA STD	MAXI KIT 77 cc Bore Ø 50 Standard stroke	MAXI KIT 77 cc ALÉSAGE Ø 50 COURSE STD				
MAXI KIT 86 cc ALESAGGIO Ø 50 CORSA 44 mm	MAXI KIT 86 cc Bore Ø 50 stroke 44 mm	MAXI KIT 86 cc ALÉSAGE Ø 50 COURSE 44 mm				
RAPPORTO ALLUNGATO secondario	SHAFT/GEARS	RAPPORT ALLONGÉ secondaire				
SERIE MOLLE CONTRASTO	VARIATOR SPRINGS SET	VARIATEUR RESSORT SET		9925630	9925630	9925630
SERIE MOLLE FRIZIONE	CLUTCH SPRINGS SET	RESSORT EMBAYAGE SET				
SCARICO NARDÒ 2 omologato	EXHAUST NARDÒ 2 Approved	ÉCHAPPEMENT NARDÒ 2 homologué		9931460	9931460	9931460
SCARICO TPR GP omologato	EXHAUST TPR GP Approved	ÉCHAPPEMENT TPR GP homologué				
VALVOLA LAMELLARE TPR	REED VALVE TPR	CLAPET À LAMELLES TPR		9931640	9931640	9931640
VARIOTOP TPR c/cinghia	VARIOTOP TPR with belt	VARIOTOP TPR avec courroie		9931300	9931300	9931300
VARIOTOP TPR s/cinghia	VARIOTOP TPR with spring	VARIOTOP TPR avec ressort		9927610	9927610	9927610

PIAGGIO	PIAGGIO	PIAGGIO	PIAGGIO	PIAGGIO	PIAGGIO	PIAGGIO	PIAGGIO	PIAGGIO	PIAGGIO	PIAGGIO	PIAGGIO
NRG PUREJET	NRG RST MC2	NTT	QUARTZ	SFERA	SFERA MA- QUILLAGE 2	SFERA RST	TYPHOON	TYPHOON	TYPHOON	TYPHOON 2T E2	TYPHOON 2T E3 CH
10-10	96-98	95-96	92-96	91-93	94-94	95-97	01-04	05-08	09-11	10-12	11-11
50cc 2T-IE LC	50cc 2T LC	50cc 2T LC	50cc 2T LC	50cc 2T AC	50cc 2T AC	50cc 2T AC	50cc 2T AC	50cc 2T AC	50cc 2T AC	50cc 2T AC	50cc 2T AC
Motore Piaggio	Motore Piaggio	Motore Piaggio	Motore Piaggio	Motore Piaggio	Motore Piaggio	Motore Piaggio	Motore Piaggio	Motore Piaggio	Motore Piaggio	Motore Piaggio	Motore Piaggio
	9926180	9926180	9926180	9926180	9926180	9926180	9926180	9926180	9926180	9926180	9926180
9923150	9923150	9923150	9923150	9923150	9923150	9923150	9923150	9923150	9923150	9923150	9923150
9929200	9929200	9929200	9929200	9929200	9929200	9929200	9929200	9929200	9929200	9929200	9929200
9928340	9928340	9928340	9928340	9928340	9928340	9928340	9928340	9928340	9928340	9928340	9928340
	9920590	9920590	9920590	9930060	9930060	9930060	9930060	9930060	9930060	9930060	9930060
	9928520	9928520	9928520	9921550	9921550	9921550	9921550	9921550	9921550	9921550	9921550
9930870	9930870	9930870	9930870	9930870	9930870	9930870	9930870	9930870	9930870	9930870	9930870
9931730	9931730	9931730	9931730	9931730	9931730	9931730	9931730	9931730	9931730	9931730	9931730
	9928390	9928390	9928390								
	9928440	9928440	9928440								
9925630	9925630	9925630	9925630	9925630	9925630	9925630	9925630	9925630	9925630	9925630	9925630
9931460	9931460	9931460	9931460	9931460	9931460	9931460	9931460	9931460	9931460	9931460	9931460
	9930160	9930160	9930160								
9931640	9931640	9931640	9931640	9931640	9931640	9931640	9931640	9931640	9931640	9931640	9931640
9931300							9931300	9931300	9931300		
9927610	9927610	9927610	9927610	9927610	9927610	9927610	9927610	9927610	9927610	9927610	9927610

SCOOTER 50cc RACING

SCOOTER 50cc RACING

TOP
- performances -



PIAGGIO	PIAGGIO	PIAGGIO	PIAGGIO
VESPA ET2	VESPA ET2	VESPA ET2 INIEZIONE	VESPA ET4
97-98	98-05	97-00	00-05
50cc 2T AC	50cc 2T AC	50cc 2T AC	50cc 4T AC
Motore Piaggio	Motore Piaggio	Motore Piaggio	Motore Piaggio

IT	EN	FR				
ALBERO MOTORE TPR CORSA STD Spinotto Ø 10	CRANKSHAFT TPR Standard stroke pin Ø10	VILEBREQUIN TPR COURSE STD Axe de piston Ø 10				
ALBERO MOTORE TPR CORSA STD Spinotto Ø 12	CRANKSHAFT TPR Standard stroke pin Ø12	VILEBREQUIN TPR COURSE STD Axe de piston Ø 12		9926180	9926180	9926180
CENTRALINA RACING	RACING CDI	Unité de contrôle RACING				
CONVERTITORE DI COPPIA	REAR VARIATOR PULLEY ASSY	POULIE SECONDAIRE		9923150	9923150	9923150
COPERCHIO INGRANAGGI	GEAR COVER	COUVERCLE ENGRENAGES				
CUSCINETTI DI BANCO TPR CARBONITRURATI Serie	BEARINGS TPR Carbonitrided Series	PALIERI DE VILEBREQUIN TPR CARBONITRURÉS Jeu		9929200	9929200	9929200
FRIZIONE TPR GP REGOLABILE Patented	CLUTCH TPR GP Adjustable Patented	EMBAYAGE TPR GP RÉGLABLE Patented		9928340	9928340	9928340
GRUPPO TERMICO RACING MAGGIORATO C/TESTA (GHISA)	RACING CYLINDER KITS BIG BORE with head (CAST IRON)	CYLINDRE COMPLET RACING MAJORÉ AVEC CULASSE (FONTE)		9930060	9930060	9930060
GRUPPO TERMICO RACING 2004 C/TESTA SCOMPOSTA (GHISA)	RACING CYLINDER KITS BIG BORE without head (CAST IRON)	CYLINDRE COMPLET RACING 2004 AVEC CULASSE DÉCOMPOSÉE (FONTE)				
GRUPPO TRASFORMAZIONE DA ARIA AD ACQUA (GHISA)	CYLINDER KIT Conversion AC to LC (CAST IRON)	GROUPE TRANSFORMATION DE L'AIR À L'EAU (FONTE)				
GRUPPO TERMICO TPR IN ALLUMINIO Ø 47,6 Spinotto Ø 10	CYLINDER KIT TPR ALLUMINIUM Ø 47,6 Pin Ø 10	CYLINDRE COMPLET TPR EN ALUMINIUM Ø 47,6 Axe de Piston Ø 10				
GRUPPO TERMICO TPR IN ALLUMINIO Ø 47,6 Spinotto Ø 12	CYLINDER KIT TPR ALLUMINIUM Ø 47,6 Pin Ø 12	CYLINDRE COMPLET TPR EN ALUMINIUM Ø 47,6 Axe de Piston Ø 12		9921550	9921550	9921550
KIT ASPIRAZIONE COMPLETO MIKUNI TPR 360	COMPLETE INLET KIT MIKUNI TM 24 TPR 360	KIT ASPIRATION COMPLET MIKUNI TM 24 TPR 360		9930870	9930870	9930870
KIT ASPIRAZIONE COMPLETO OKO 28	COMPLETE INLET KIT OKO 28 TPR 360	KIT ASPIRATION COMPLET OKO 28 TPR 360		9931730	9931730	9931730
MAXI KIT 77 cc ALESAGGIO Ø 50 CORSA STD	MAXI KIT 77 cc Bore Ø 50 Standard stroke	MAXI KIT 77 cc ALÉSAGE Ø 50 COURSE STD				
MAXI KIT 86 cc ALESAGGIO Ø 50 CORSA 44 mm	MAXI KIT 86 cc Bore Ø 50 stroke 44 mm	MAXI KIT 86 cc ALÉSAGE Ø 50 COURSE 44 mm				
RAPPORTO ALLUNGATO secondario	SHAFT/GEARS	RAPPORT ALLONGÉ secondaire				
SERIE MOLLE CONTRASTO	VARIATOR SPRINGS SET	VARIATEUR RESSORT SET		9925630	9925630	9925630
SERIE MOLLE FRIZIONE	CLUTCH SPRINGS SET	RESSORT EMBAYAGE SET				
SCARICO NARDÒ 2 omologato	EXHAUST NARDÒ 2 Approved	ÉCHAPPEMENT NARDÒ 2 homologué		9931460	9931460	9931460
SCARICO TPR GP omologato	EXHAUST TPR GP Approved	ÉCHAPPEMENT TPR GP homologué				
VALVOLA LAMELLARE TPR	REED VALVE TPR	CLAPET À LAMELLES TPR		9931640	9931640	9931640
VARIOTOP TPR c/cinghia	VARIOTOP TPR with belt	VARIOTOP TPR avec courroie				9931260
VARIOTOP TPR s/cinghia	VARIOTOP TPR with spring	VARIOTOP TPR avec ressort		9927610	9927610	9927610

PIAGGIO	PIAGGIO	PIAGGIO	PIAGGIO	PIAGGIO	PIAGGIO	PIAGGIO	PIAGGIO	PIAGGIO	PIAGGIO	PIAGGIO	PIAGGIO
VESPA LX 2T	VESPA LX 2T	VESPA LX 2T TOURING & 30KM	VESPA LX 4T	VESPA LX 4T 4V	VESPA LX 4T 4V TOURING	VESPA LXV 2T	VESPA LXV 2T NAVY	VESPA PRIMA- VERA 4T 3V NOABS E4	VESPA S 2T & COLLEGE	VESPA S 4T 4V & COLLEGE	VESPA SPRINT 4T 3V E4
05-08	09-13	10-13	05-09	09-13	10-13	06-09	08-08	17-18	07-12	08-12	17-20
50cc 2T AC	50cc 2T AC	50cc 2T AC	50cc 4T AC	50cc 4T-4V AC	50cc 4T-4V AC	50cc 2T AC	50cc 2T AC	50cc 4T-3V AC	50cc 2T AC	50cc 4T-4V AC	50cc 4T-3V AC
Motore Piaggio	Motore Piaggio	Motore Piaggio	Motore Piaggio	Motore Piaggio	Motore Piaggio	Motore Piaggio	Motore Piaggio	Motore Piaggio	Motore Piaggio	Motore Piaggio	Motore Piaggio
9926180	9926180	9926180				9926180	9926180		9926180		
9923150	9923150	9923150	9923150	9923150	9923150	9923150	9923150		9923150	9923150	
9929200	9929200	9929200				9929200	9929200		9929200		
9928340	9928340	9928340	9928340	9928340	9928340	9928340	9928340		9928340	9928340	
9930060	9930060	9930060				9930060	9930060		9930060		
9921550	9921550	9921550				9921550	9921550		9921550		
9930870	9930870	9930870				9930870	9930870		9930870		
9931730	9931730	9931730				9931730	9931730		9931730		
9925630	9925630	9925630	9925630	9925630	9925630	9925630	9925630		9925630	9925630	
9931460	9931460	9931460				9931460	9931460		9931460		
9931640	9931640	9931640				9931640	9931640		9931640		
9931260	9931260	9931260	9931260	9931260	9931260	9931260	9931260		9931260	9931260	
9927610	9927610	9927610	9927610	9927610	9927610	9927610	9927610	9927610	9927610	9927610	9927610

SCOOTER 50cc
RACING

SCOOTER 50cc RACING

TOP
- performances -



PIAGGIO PIAGGIO PIAGGIO PIAGGIO

ZIP ZIP ZIP 2T ZIP 4T

92-93 95-96 08-13 00-05

50cc 2T AC 50cc 2T AC 50cc 2T LC 50cc 4T AC

Motore Piaggio Motore Piaggio Motore Piaggio Motore Piaggio

IT	EN	FR				
ALBERO MOTORE TPR CORSA STD Spinotto Ø 10	CRANKSHAFT TPR Standard stroke pin Ø10	VILEBREQUIN TPR COURSE STD Axe de piston Ø 10				
ALBERO MOTORE TPR CORSA STD Spinotto Ø 12	CRANKSHAFT TPR Standard stroke pin Ø12	VILEBREQUIN TPR COURSE STD Axe de piston Ø 12		9926180	9926180	9926180
CENTRALINA RACING	RACING CDI	Unité de contrôle RACING				
CONVERTITORE DI COPPIA	REAR VARIATOR PULLEY ASSY	POULIE SECONDAIRE		9923150	9923150	9923150
COPERCHIO INGRANAGGI	GEAR COVER	COUVERCLE ENGRENAGES				
CUSCINETTI DI BANCO TPR CARBONITRURATI Serie	BEARINGS TPR Carbonitrided Series	PALIERI DE VILEBREQUIN TPR CARBONITRURÉS Jeu		9929200	9929200	9929200
FRIZIONE TPR GP REGOLABILE Patented	CLUTCH TPR GP Adjustable Patented	EMBAYAGE TPR GP RÉGLABLE Patented		9928340	9928340	9928340
GRUPPO TERMICO RACING MAGGIORATO C/TESTA (GHISA)	RACING CYLINDER KITS BIG BORE with head (CAST IRON)	CYLINDRE COMPLET RACING MAJORÉ AVEC CULASSE (FONTE)		9930060	9930060	9920590
GRUPPO TERMICO RACING 2004 C/TESTA SCOMPOSTA (GHISA)	RACING CYLINDER KITS BIG BORE without head (CAST IRON)	CYLINDRE COMPLET RACING 2004 AVEC CULASSE DÉCOMPOSÉE (FONTE)				
GRUPPO TRASFORMAZIONE DA ARIA AD ACQUA (GHISA)	CYLINDER KIT Conversion AC to LC (CAST IRON)	GROUPE TRANSFORMATION DE L'AIR À L'EAU (FONTE)				
GRUPPO TERMICO TPR IN ALLUMINIO Ø 47,6 Spinotto Ø 10	CYLINDER KIT TPR ALLUMINIUM Ø 47,6 Pin Ø 10	CYLINDRE COMPLET TPR EN ALUMINIUM Ø 47,6 Axe de Piston Ø 10				
GRUPPO TERMICO TPR IN ALLUMINIO Ø 47,6 Spinotto Ø 12	CYLINDER KIT TPR ALLUMINIUM Ø 47,6 Pin Ø 12	CYLINDRE COMPLET TPR EN ALUMINIUM Ø 47,6 Axe de Piston Ø 12		9921550	9921550	9928520
KIT ASPIRAZIONE COMPLETO MIKUNI TPR 360	COMPLETE INLET KIT MIKUNI TM 24 TPR 360	KIT ASPIRATION COMPLET MIKUNI TM 24 TPR 360		9930870	9930870	9930870
KIT ASPIRAZIONE COMPLETO OKO 28	COMPLETE INLET KIT OKO 28 TPR 360	KIT ASPIRATION COMPLET OKO 28 TPR 360		9931730	9931730	9931730
MAXI KIT 77 cc ALESAGGIO Ø 50 CORSA STD	MAXI KIT 77 cc Bore Ø 50 Standard stroke	MAXI KIT 77 cc ALÉSAGE Ø 50 COURSE STD				9928390
MAXI KIT 86 cc ALESAGGIO Ø 50 CORSA 44 mm	MAXI KIT 86 cc Bore Ø 50 stroke 44 mm	MAXI KIT 86 cc ALÉSAGE Ø 50 COURSE 44 mm				9928440
RAPPORTO ALLUNGATO secondario	SHAFT/GEARS	RAPPORT ALLONGÉ secondaire				
SERIE MOLLE CONTRASTO	VARIATOR SPRINGS SET	VARIATEUR RESSORT SET		9925630	9925630	9925630
SERIE MOLLE FRIZIONE	CLUTCH SPRINGS SET	RESSORT EMBRAYAGE SET				
SCARICO NARDÒ 2 omologato	EXHAUST NARDÒ 2 Approved	ÉCHAPPEMENT NARDÒ 2 homologué		9931460	9931460	9931460
SCARICO TPR GP omologato	EXHAUST TPR GP Approved	ÉCHAPPEMENT TPR GP homologué				9930160
VALVOLA LAMELLARE TPR	REED VALVE TPR	CLAPET À LAMELLES TPR		9931640	9931640	9931640
VARIOTOP TPR c/cinghia	VARIOTOP TPR with belt	VARIOTOP TPR avec courroie				9931260
VARIOTOP TPR s/cinghia	VARIOTOP TPR with spring	VARIOTOP TPR avec ressort		9927610	9927610	9927610

PIAGGIO	PIAGGIO	PIAGGIO	PIAGGIO	PIAGGIO	PIAGGIO	PIAGGIO	PIAGGIO	PIAGGIO	PIAGGIO	RIEJU	RIEJU	SYM
ZIP 4T	ZIP BIMODALE	ZIP FAST RIDER	ZIP FAST RIDER RST	ZIP LC	ZIP RST	ZIP SP	ZIP SP	ZIP SP EURO 2	FIRST	WINDY	SYMPLY EURO 2	
06-13	94-97	93-94	96-97	00-04	96-99	96-00	01-04	06-13	95-98	95-98	07-08	
50cc 4T AC	50cc 2T AC	50cc 2T AC	50cc 2T AC	50cc 2T LC	50cc 2T AC	50cc 2T LC	50cc 2T LC	50cc 2T LC	50cc 2T AC	50cc 2T AC	50cc 4T AC	
Motore Piaggio	Motore Piaggio	Motore Piaggio	Motore Piaggio	Motore Piaggio	Motore Piaggio	Motore Piaggio	Motore Piaggio	Motore Piaggio	MY	MY	Tipo Kymco	
									9925910	9925910		
	9926180	9926180	9926180	9926180	9926180	9926180	9926180	9926180	9928320	9928320		
9923150	9923150	9923150	9923150	9923150	9923150	9923150	9923150	9923150	9923030	9923030		
									9930300	9930300		
	9929200	9929200	9929200	9929200	9929200	9929200	9929200	9929200	9929190	9929190		
9928340	9928340	9928340	9928340	9928340	9928340	9928340	9928340	9928340	9927450	9927450		
	9930060	9930060	9930060	9920590	9930060	9920590	9920590	9920590	9930030	9930030		
									9911210	9911210		
									9921630	9921630		
	9921550	9921550	9921550	9928520	9921550	9928520	9928520	9928520				
	9930870	9930870	9930870	9930870	9930870	9930870	9930870	9930870	9930830	9930830		
	9931730	9931730	9931730	9931730	9931730	9931730	9931730	9931730	9931710	9931710		
				9928390		9928390	9928390	9928390				
				9928440		9928440	9928440	9928440				
									990875P	990875P		
9925630	9925630	9925630	9925630	9925630	9925630	9925630	9925630	9925630	9925620	9925620		
									9908240	9908240		
	9931460	9931460	9931460	9931460	9931460	9931460	9931460	9931460				
				9930160		9930160	9930160	9930160				
	9931640	9931640	9931640	9931640	9931640	9931640	9931640	9931640	9931620	9931620		
9931260				9931260		9931260	9931260	9931260	9931670	9931670		
9927610	9927610	9927610	9927610	9927610	9927610	9927610	9927610	9927610	9931650	9931650	9937610	

SCOOTER 50cc RACING

SCOOTER 50cc RACING

TOP
- performances -



YAMAHA	YAMAHA	YAMAHA	YAMAHA
AEROX	AEROX	AEROX	AEROX
97-12	01-02	04-04	05-05
50cc 2T LC	50cc 2T LC	50cc 2T LC	50cc 2T LC
MA	MA	MA	MA

IT	EN	FR				
ALBERO MOTORE TPR CORSA STD Spinotto Ø 10	CRANKSHAFT TPR Standard stroke pin Ø10	VILEBREQUIN TPR COURSE STD Axe de piston Ø 10		9925910	9925910	9925910
ALBERO MOTORE TPR CORSA STD Spinotto Ø 12	CRANKSHAFT TPR Standard stroke pin Ø12	VILEBREQUIN TPR COURSE STD Axe de piston Ø 12		9928320	9928320	9928320
CENTRALINA RACING	RACING CDI	Unité de contrôle RACING				9921790
CONVERTITORE DI COPPIA	REAR VARIATOR PULLEY ASSY	POULIE SECONDAIRE		9923030	9923030	9923030
COPERCHIO INGRANAGGI	GEAR COVER	COUVERCLE ENGRENAGES		9930300	9930300	9930300
CUSCINETTI DI BANCO TPR CARBONITRURATI Serie	BEARINGS TPR Carbonitrided Series	PALIERI DE VILEBREQUIN TPR CARBONITRURÉS Jeu		9929190	9929190	9929190
FRIZIONE TPR GP REGOLABILE Patented	CLUTCH TPR GP Adjustable Patented	EMBRAYAGE TPR GP RÉGLABLE Patented		9927450	9927450	9927450
GRUPPO TERMICO RACING MAGGIORATO C/TESTA (GHISA)	RACING CYLINDER KITS BIG BORE with head (CAST IRON)	CYLINDRE COMPLET RACING MAJORÉ AVEC CULASSE (FONTE)		9912800	9912800	9912800
GRUPPO TERMICO RACING 2004 C/TESTA SCOMPOSTA (GHISA)	RACING CYLINDER KITS BIG BORE without head (CAST IRON)	CYLINDRE COMPLET RACING 2004 AVEC CULASSE DÉCOMPOSÉE (FONTE)		9921160	9921160	9921160
GRUPPO TRASFORMAZIONE DA ARIA AD ACQUA (GHISA)	CYLINDER KIT Conversion AC to LC (CAST IRON)	GROUPE TRANSFORMATION DE L'AIR À L'EAU (FONTE)				
GRUPPO TERMICO TPR IN ALLUMINIO Ø 47,6 Spinotto Ø 10	CYLINDER KIT TPR ALLUMINIUM Ø 47,6 Pin Ø 10	CYLINDRE COMPLET TPR EN ALUMINIUM Ø 47,6 Axe de Piston Ø 10		9928480	9928480	9928480
GRUPPO TERMICO TPR IN ALLUMINIO Ø 47,6 Spinotto Ø 12	CYLINDER KIT TPR ALLUMINIUM Ø 47,6 Pin Ø 12	CYLINDRE COMPLET TPR EN ALUMINIUM Ø 47,6 Axe de Piston Ø 12		9928550	9928550	9928550
KIT ASPIRAZIONE COMPLETO MIKUNI TPR 360	COMPLETE INLET KIT MIKUNI TM 24 TPR 360	KIT ASPIRATION COMPLET MIKUNI TM 24 TPR 360		9930830	9930830	9930830
KIT ASPIRAZIONE COMPLETO OKO 28	COMPLETE INLET KIT OKO 28 TPR 360	KIT ASPIRATION COMPLET OKO 28 TPR 360		9931710	9931710	9931710
MAXI KIT 77 cc ALESAGGIO Ø 50 CORSA STD	MAXI KIT 77 cc Bore Ø 50 Standard stroke	MAXI KIT 77 cc ALÉSAGE Ø 50 COURSE STD		9926580	9926580	9926580
MAXI KIT 86 cc ALESAGGIO Ø 50 CORSA 44 mm	MAXI KIT 86 cc Bore Ø 50 stroke 44 mm	MAXI KIT 86 cc ALÉSAGE Ø 50 COURSE 44 mm		9926560	9926560	9926560
RAPPORTO ALLUNGATO secondario	SHAFT/GEARS	RAPPORT ALLONGÉ secondaire		990875P	990875P	990875P
SERIE MOLLE CONTRASTO	VARIATOR SPRINGS SET	VARIATEUR RESSORT SET		9925620	9925620	9925620
SERIE MOLLE FRIZIONE	CLUTCH SPRINGS SET	RESSORT EMBRAYAGE SET		9908240 9912740	9908240 9912740	9908240 9912740
SCARICO NARDÒ 2 omologato	EXHAUST NARDÒ 2 Approved	ÉCHAPPEMENT NARDÒ 2 homologué		9931440	9931440	9931440
SCARICO TPR GP omologato	EXHAUST TPR GP Approved	ÉCHAPPEMENT TPR GP homologué		9930140	9930140	9930140
VALVOLA LAMELLARE TPR	REED VALVE TPR	CLAPET À LAMELLES TPR		9931620	9931620	9931620
VARIOTOP TPR c/cinghia	VARIOTOP TPR with belt	VARIOTOP TPR avec courroie		9931670	9931670	9931670
VARIOTOP TPR s/cinghia	VARIOTOP TPR with spring	VARIOTOP TPR avec ressort		9931650	9931650	9931650

YAMAHA	YAMAHA	YAMAHA	YAMAHA	YAMAHA	YAMAHA	YAMAHA	YAMAHA	YAMAHA	YAMAHA	YAMAHA	YAMAHA
AEROX	AEROX	AEROX	AEROX	AEROX	AEROX	AEROX EURO 2	AEROX NAKED	AEROX R	AEROX R	AXIS	BREEZE
06-06	07-07	08-08	09-09	10-12	13-16	03-03	13-16	99-99	99-00	95-96	94-95
50cc 2T LC	50cc 2T LC	50cc 2T LC	50cc 2T LC	50cc 2T LC	50cc 2T LC	50cc 2T LC	50cc 2T LC	50cc 2T LC	50cc 2T LC	50cc 2T AC	50cc 2T AC
MA	MA	MA	MA	MA	MA	MA	MA	MA	MA	CY	CY
9925910	9925910	9925910	9925910	9925910	9925910	9925910	9925910	9925910	9925910	9925910	9925910
9928320	9928320	9928320	9928320	9928320	9928320	9928320	9928320	9928320	9928320	9928320	9928320
9921790	9921790	9921790	9921790	9921790	9921790	9921790	9921790	9921790			
9923030	9923030	9923030	9923030	9923030	9923030	9923030	9923030	9923030	9923030	9923030	9923030
9930300	9930300	9930300	9930300	9930300	9930300	9930300	9930300	9930300	9930300		
9929190	9929190	9929190	9929190	9929190	9929190	9929190	9929190	9929190	9929190	9929190	9929190
9927450	9927450	9927450	9927450	9927450	9927450	9927450	9927450	9927450	9927450		
9912800	9912800	9912800	9912800	9912800	9912800	9912800	9912800	9912800	9912800	9930030	9930030
9921160	9921160	9921160	9921160	9921160	9921160	9921160	9921160	9921160	9921160		
										9911210	9911210
9928480	9928480	9928480	9928480	9928480	9928480	9928480	9928480	9928480	9928480	9921630	9921630
9928550	9928550	9928550	9928550	9928550	9928550	9928550	9928550	9928550	9928550		
9930830	9930830	9930830	9930830	9930830	9930830	9930830	9930830	9930830	9930830	9930830	9930830
9931710	9931710	9931710	9931710	9931710	9931710	9931710	9931710	9931710	9931710	9931710	9931710
9926580	9926580	9926580	9926580	9926580	9926580	9926580	9926580	9926580	9926580		
9926560	9926560	9926560	9926560	9926560	9926560	9926560	9926560	9926560	9926560		
990875P	990875P	990875P	990875P	990875P	990875P	990875P	990875P	990875P	990875P		
9925620	9925620	9925620	9925620	9925620	9925620	9925620	9925620	9925620	9925620	9925620	9925620
9908240 9912740	9908240 9912740	9908240 9912740	9908240 9912740	9908240 9912740	9908240 9912740	9908240 9912740	9908240 9912740	9908240 9912740	9908240 9912740	9908240 9912740	
9931440	9931440	9931440	9931440	9931440	9931440	9931440	9931440	9931440	9931440	9931440	9931440
9930140	9930140	9930140	9930140	9930140	9930140	9930140	9930140	9930140	9930140		
9931620	9931620	9931620	9931620	9931620	9931620	9931620	9931620	9931620	9931620	9931620	9931620
9931670	9931670	9931670	9931670	9931670	9931670	9931670	9931670	9931670	9931670	9931690	9931690
9931650	9931650	9931650	9931650	9931650	9931650	9931650	9931650	9931650	9931650	9931650	9931650

SCOOTER 50cc RACING

SCOOTER 50cc RACING



YAMAHA	YAMAHA	YAMAHA	YAMAHA
BW'S	BW'S	BW'S	BW'S
97-04	04-05	06-07	08-12
50cc 2T AC	50cc 2T AC	50cc 2T AC	50cc 2T AC
CW	CW	CW	CW

IT	EN	FR					
ALBERO MOTORE TPR CORSA STD Spinotto Ø 10	CRANKSHAFT TPR Standard stroke pin Ø10	VILEBREQUIN TPR COURSE STD Axe de piston Ø 10		9927900	9927900	9927900	9927900
ALBERO MOTORE TPR CORSA STD Spinotto Ø 12	CRANKSHAFT TPR Standard stroke pin Ø12	VILEBREQUIN TPR COURSE STD Axe de piston Ø 12					
CENTRALINA RACING	RACING CDI	Unité de contrôle RACING			9921790	9921790	9921790
CONVERTITORE DI COPPIA	REAR VARIATOR PULLEY ASSY	POULIE SECONDAIRE		9923030	9923030	9923030	9923030
COPERCHIO INGRANAGGI	GEAR COVER	COUVERCLE ENGRENAGES		9930300	9930300	9930300	9930300
CUSCINETTI DI BANCO TPR CARBONITRURATI Serie	BEARINGS TPR Carbonitrided Series	PALIERI DE VILEBREQUIN TPR CARBONITRURÉS Jeu		9929190	9929190	9929190	9929190
FRIZIONE TPR GP REGOLABILE Patented	CLUTCH TPR GP Adjustable Patented	EMBRAYAGE TPR GP RÉGLABLE Patented		9927450	9927450	9927450	9927450
GRUPPO TERMICO RACING MAGGIORATO C/TESTA (GHISA)	RACING CYLINDER KITS BIG BORE with head (CAST IRON)	CYLINDRE COMPLET RACING MAJORÉ AVEC CULASSE (FONTE)		9930000	9930000	9930000	9930000
GRUPPO TERMICO RACING 2004 C/TESTA SCOMPOSTA (GHISA)	RACING CYLINDER KITS BIG BORE without head (CAST IRON)	CYLINDRE COMPLET RACING 2004 AVEC CULASSE DÉCOMPOSÉE (FONTE)					
GRUPPO TRASFORMAZIONE DA ARIA AD ACQUA (GHISA)	CYLINDER KIT Conversion AC to LC (CAST IRON)	GROUPE TRANSFORMATION DE L'AIR À L'EAU (FONTE)					
GRUPPO TERMICO TPR IN ALLUMINIO Ø 47,6 Spinotto Ø 10	CYLINDER KIT TPR ALLUMINIUM Ø 47,6 Pin Ø 10	CYLINDRE COMPLET TPR EN ALUMINIUM Ø 47,6 Axe de Piston Ø 10		9921640	9921640	9921640	9921640
GRUPPO TERMICO TPR IN ALLUMINIO Ø 47,6 Spinotto Ø 12	CYLINDER KIT TPR ALLUMINIUM Ø 47,6 Pin Ø 12	CYLINDRE COMPLET TPR EN ALUMINIUM Ø 47,6 Axe de Piston Ø 12					
KIT ASPIRAZIONE COMPLETO MIKUNI TPR 360	COMPLETE INLET KIT MIKUNI TM 24 TPR 360	KIT ASPIRATION COMPLET MIKUNI TM 24 TPR 360					
KIT ASPIRAZIONE COMPLETO OKO 28	COMPLETE INLET KIT OKO 28 TPR 360	KIT ASPIRATION COMPLET OKO 28 TPR 360					
MAXI KIT 77 cc ALESAGGIO Ø 50 CORSA STD	MAXI KIT 77 cc Bore Ø 50 Standard stroke	MAXI KIT 77 cc ALÉSAGE Ø 50 COURSE STD					
MAXI KIT 86 cc ALESAGGIO Ø 50 CORSA 44 mm	MAXI KIT 86 cc Bore Ø 50 stroke 44 mm	MAXI KIT 86 cc ALÉSAGE Ø 50 COURSE 44 mm					
RAPPORTO ALLUNGATO secondario	SHAFT/GEARS	RAPPORT ALLONGÉ secondaire		990875P	990875P	990875P	990875P
SERIE MOLLE CONTRASTO	VARIATOR SPRINGS SET	VARIATEUR RESSORT SET		9925620	9925620	9925620	9925620
SERIE MOLLE FRIZIONE	CLUTCH SPRINGS SET	RESSORT EMBRAYAGE SET		9908240 9912740	9908240 9912740	9908240 9912740	9908240 9912740
SCARICO NARDÒ 2 omologato	EXHAUST NARDÒ 2 Approved	ÉCHAPPEMENT NARDÒ 2 homologué		9931450			
SCARICO TPR GP omologato	EXHAUST TPR GP Approved	ÉCHAPPEMENT TPR GP homologué					
VALVOLA LAMELLARE TPR	REED VALVE TPR	CLAPET À LAMELLES TPR					
VARIOTOP TPR c/cinghia	VARIOTOP TPR with belt	VARIOTOP TPR avec courroie		9931670	9931670	9931670	9931670
VARIOTOP TPR s/cinghia	VARIOTOP TPR with spring	VARIOTOP TPR avec ressort		9931650	9931650	9931650	9931650

YAMAHA	YAMAHA	YAMAHA	YAMAHA	YAMAHA	YAMAHA	YAMAHA	YAMAHA	YAMAHA	YAMAHA	YAMAHA	YAMAHA
BW'S	BW'S BUMP	BW'S EASY	BW'S NAKED	BW'S NAKED	BW'S NAKED	BW'S NAKED	BW'S NEXT GENERATION	BW'S NEXT GENERATION	BW'S NEXT GENERATION	BW'S NEXT GENERATION	BW'S NEXT GENERATION
13-16	97-98	13-13	03-03	04-04	09-12	13-16	97-98	99-99	99-00	01-02	03-03
50cc 2T AC	50cc 2T AC	50cc 2T AC	50cc 2T AC	50cc 2T AC	50cc 2T AC	50cc 2T AC	50cc 2T AC	50cc 2T AC	50cc 2T AC	50cc 2T AC	50cc 2T AC
CW	CW	CW	CW	CW	CW	CW	CW	CW	CW	CW	CW
9927900	9927900	9927900	9927900	9927900	9927900	9927900	9927900	9927900	9927900	9927900	9927900
9921790		9921790		9921790	9921790	9921790					9921790
9923030	9923030	9923030	9923030	9923030	9923030	9923030	9923030	9923030	9923030	9923030	9923030
9930300	9930300	9930300	9930300	9930300	9930300	9930300	9930300	9930300	9930300	9930300	9930300
9929190	9929190	9929190	9929190	9929190	9929190	9929190	9929190	9929190	9929190	9929190	9929190
9927450	9927450	9927450	9927450	9927450	9927450	9927450	9927450	9927450	9927450	9927450	9927450
9930000	9930000	9930000	9930000	9930000	9930000	9930000	9930000	9930000	9930000	9930000	9930000
9921640	9921640	9921640	9921640	9921640	9921640	9921640	9921640	9921640	9921640	9921640	9921640
990875P	990875P	990875P	990875P	990875P	990875P	990875P	990875P	990875P	990875P	990875P	990875P
9925620	9925620	9925620	9925620	9925620	9925620	9925620	9925620	9925620	9925620	9925620	9925620
9908240 9912740	9908240 9912740	9908240 9912740	9908240 9912740	9908240 9912740	9908240 9912740	9908240 9912740	9908240 9912740	9908240 9912740	9908240 9912740	9908240 9912740	9908240 9912740
	9931450		9931450				9931450	9931450	9931450	9931450	
9931670	9931670	9931670	9931670	9931670	9931670	9931670	9931670	9931670	9931670	9931670	9931670
9931650	9931650	9931650	9931650	9931650	9931650	9931650	9931650	9931650	9931650	9931650	9931650

SCOOTER 50cc
RACING

SCOOTER 50cc RACING

TOP
- performances -



YAMAHA	YAMAHA	YAMAHA	YAMAHA
BW'S NEXT GENERATION	BW'S ORIGINAL	BW'S ORIGINAL	BW'S ORIGINAL
04-06	99-99	99-00	01-01
50cc 2T AC	50cc 2T AC	50cc 2T AC	50cc 2T AC
CW	CW	CW	CW

IT	EN	FR				
ALBERO MOTORE TPR CORSA STD Spinotto Ø 10	CRANKSHAFT TPR Standard stroke pin Ø10	VILEBREQUIN TPR COURSE STD Axe de piston Ø 10		9927900	9927900	9927900
ALBERO MOTORE TPR CORSA STD Spinotto Ø 12	CRANKSHAFT TPR Standard stroke pin Ø12	VILEBREQUIN TPR COURSE STD Axe de piston Ø 12				
CENTRALINA RACING	RACING CDI	Unité de contrôle RACING		9921790		
CONVERTITORE DI COPPIA	REAR VARIATOR PULLEY ASSY	POULIE SECONDAIRE		9923030	9923030	9923030
COPERCHIO INGRANAGGI	GEAR COVER	COUVERCLE ENGRENAGES		9930300	9930300	9930300
CUSCINETTI DI BANCO TPR CARBONITRURATI Serie	BEARINGS TPR Carbonitrided Series	PALIERI DE VILEBREQUIN TPR CARBONITRURÉS Jeu		9929190	9929190	9929190
FRIZIONE TPR GP REGOLABILE Patented	CLUTCH TPR GP Adjustable Patented	EMBRAYAGE TPR GP RÉGLABLE Patented		9927450	9927450	9927450
GRUPPO TERMICO RACING MAGGIORATO C/TESTA (GHISA)	RACING CYLINDER KITS BIG BORE with head (CAST IRON)	CYLINDRE COMPLET RACING MAJORÉ AVEC CULASSE (FONTE)		9930000	9930000	9930000
GRUPPO TERMICO RACING 2004 C/TESTA SCOMPOSTA (GHISA)	RACING CYLINDER KITS BIG BORE without head (CAST IRON)	CYLINDRE COMPLET RACING 2004 AVEC CULASSE DÉCOMPOSÉE (FONTE)				
GRUPPO TRASFORMAZIONE DA ARIA AD ACQUA (GHISA)	CYLINDER KIT Conversion AC to LC (CAST IRON)	GROUPE TRANSFORMATION DE L'AIR À L'EAU (FONTE)				
GRUPPO TERMICO TPR IN ALLUMINIO Ø 47,6 Spinotto Ø 10	CYLINDER KIT TPR ALLUMINIUM Ø 47,6 Pin Ø 10	CYLINDRE COMPLET TPR EN ALUMINIUM Ø 47,6 Axe de Piston Ø 10		9921640	9921640	9921640
GRUPPO TERMICO TPR IN ALLUMINIO Ø 47,6 Spinotto Ø 12	CYLINDER KIT TPR ALLUMINIUM Ø 47,6 Pin Ø 12	CYLINDRE COMPLET TPR EN ALUMINIUM Ø 47,6 Axe de Piston Ø 12				
KIT ASPIRAZIONE COMPLETO MIKUNI TPR 360	COMPLETE INLET KIT MIKUNI TM 24 TPR 360	KIT ASPIRATION COMPLET MIKUNI TM 24 TPR 360				
KIT ASPIRAZIONE COMPLETO OKO 28	COMPLETE INLET KIT OKO 28 TPR 360	KIT ASPIRATION COMPLET OKO 28 TPR 360				
MAXI KIT 77 cc ALESAGGIO Ø 50 CORSA STD	MAXI KIT 77 cc Bore Ø 50 Standard stroke	MAXI KIT 77 cc ALÉSAGE Ø 50 COURSE STD				
MAXI KIT 86 cc ALESAGGIO Ø 50 CORSA 44 mm	MAXI KIT 86 cc Bore Ø 50 stroke 44 mm	MAXI KIT 86 cc ALÉSAGE Ø 50 COURSE 44 mm				
RAPPORTO ALLUNGATO secondario	SHAFT/GEARS	RAPPORT ALLONGÉ secondaire		990875P	990875P	990875P
SERIE MOLLE CONTRASTO	VARIATOR SPRINGS SET	VARIATEUR RESSORT SET		9925620	9925620	9925620
SERIE MOLLE FRIZIONE	CLUTCH SPRINGS SET	RESSORT EMBRAYAGE SET		9908240 9912740	9908240 9912740	9908240 9912740
SCARICO NARDÒ 2 omologato	EXHAUST NARDÒ 2 Approved	ÉCHAPPEMENT NARDÒ 2 homologué			9931450	9931450
SCARICO TPR GP omologato	EXHAUST TPR GP Approved	ÉCHAPPEMENT TPR GP homologué				
VALVOLA LAMELLARE TPR	REED VALVE TPR	CLAPET À LAMELLES TPR				
VARIOTOP TPR c/cinghia	VARIOTOP TPR with belt	VARIOTOP TPR avec courroie		9931670	9931670	9931670
VARIOTOP TPR s/cinghia	VARIOTOP TPR with spring	VARIOTOP TPR avec ressort		9931650	9931650	9931650

YAMAHA	YAMAHA	YAMAHA	YAMAHA	YAMAHA	YAMAHA	YAMAHA	YAMAHA	YAMAHA	YAMAHA	YAMAHA	YAMAHA
BW'S ORIGINAL	BW'S ORIGINAL EURO 2	CRZ	CT	GIGGLE	JOG	JOG ER	JOG R	JOG R EURO2	JOG R EURO2	JOG R EURO2	JOG R LC
01-02	03-03	91-95	90-95	08-08	92-01	00-02	02-02	02-02	06-12	13-15	02-15
50cc 2T AC	50cc 2T AC	50cc 2T AC	50cc 2T AC	50cc 4T-3V LC	50cc 2T AC	50cc 2T AC	50cc 2T AC	50cc 2T AC	50cc 2T AC	50cc 2T AC	50cc 2T LC
CW	CW	Tipo CW	Tipo CW	15P1	Tipo CY	Tipo CY	MY	MY	MY	MY	MA
9927900	9927900				9925910		9925910	9925910	9925910	9925910	9925910
					9928320		9928320	9928320	9928320	9928320	9928320
							9921790	9921790	9921790	9921790	9921790
9923030	9923030				9923030		9923030	9923030	9923030	9923030	9923030
9930300	9930300						9930300	9930300	9930300	9930300	9930300
9929190	9929190				9929190	9929190	9929190	9929190	9929190	9929190	9929190
9927450	9927450	9927450	9927450				9927450	9927450	9927450	9927450	9927450
9930000	9930000				9930030	9930030	9930030	9930030	9930030	9930030	9912800
											9921160
					9911210	9911210	9911210	9911210	9911210	9911210	9911210
9921640	9921640			9926330	9921630	9921630	9921630	9921630	9921630	9921630	9928480
											9928550
					9930830	9930830	9930830	9930830	9930830	9930830	9930830
					9931710	9931710	9931710	9931710	9931710	9931710	9931710
											9926580
											9926560
990875P	990875P						990875P	990875P	990875P	990875P	990875P
9925620	9925620			9925620			9925620	9925620	9925620	9925620	9925620
9908240 9912740	9908240 9912740	9908240	9908240	9912740			9908240 9912740	9908240 9912740	9908240 9912740	9908240 9912740	9908240 9912740
9931450					9931440	9931440	9931440	9931440	9931440	9931440	9931440
											9930140
					9931620		9931620	9931620	9931620	9931620	9931620
9931670	9931670				9931690		9931670	9931670	9931670	9931670	9931670
9931650	9931650			9926130	9931650		9931650	9931650	9931650	9931650	9931650

SCOOTER 50cc
RACING

SCOOTER 50cc RACING

TOP
- performances -



YAMAHA	YAMAHA	YAMAHA	YAMAHA
JOG Z	NEO'S	NEO'S	NEO'S
95-95	97-13	02-02	04-06
50cc 2T AC	50cc 2T AC	50cc 2T AC	50cc 2T AC
Tipo CY	MY	MY	MY

IT	EN	FR					
ALBERO MOTORE TPR CORSA STD Spinotto Ø 10	CRANKSHAFT TPR Standard stroke pin Ø10	VILEBREQUIN TPR COURSE STD Axe de piston Ø 10			9925910	9925910	9925910
ALBERO MOTORE TPR CORSA STD Spinotto Ø 12	CRANKSHAFT TPR Standard stroke pin Ø12	VILEBREQUIN TPR COURSE STD Axe de piston Ø 12			9928320	9928320	9928320
CENTRALINA RACING	RACING CDI	Unité de contrôle RACING					9921790
CONVERTITORE DI COPPIA	REAR VARIATOR PULLEY ASSY	POULIE SECONDAIRE			9923030	9923030	9923030
COPERCHIO INGRANAGGI	GEAR COVER	COUVERCLE ENGRENAGES			9930300	9930300	9930300
CUSCINETTI DI BANCO TPR CARBONITRURATI Serie	BEARINGS TPR Carbonitrided Series	PALIERI DE VILEBREQUIN TPR CARBONITRURÉS Jeu			9929190	9929190	9929190
FRIZIONE TPR GP REGOLABILE Patented	CLUTCH TPR GP Adjustable Patented	EMBRAYAGE TPR GP RÉGLABLE Patented			9927450	9927450	9927450
GRUPPO TERMICO RACING MAGGIORATO C/TESTA (GHISA)	RACING CYLINDER KITS BIG BORE with head (CAST IRON)	CYLINDRE COMPLET RACING MAJORÉ AVEC CULASSE (FONTE)			9930030	9930030	9930030
GRUPPO TERMICO RACING 2004 C/TESTA SCOMPOSTA (GHISA)	RACING CYLINDER KITS BIG BORE without head (CAST IRON)	CYLINDRE COMPLET RACING 2004 AVEC CULASSE DÉCOMPOSÉE (FONTE)					
GRUPPO TRASFORMAZIONE DA ARIA AD ACQUA (GHISA)	CYLINDER KIT Conversion AC to LC (CAST IRON)	GROUPE TRANSFORMATION DE L'AIR À L'EAU (FONTE)			9911210	9911210	9911210
GRUPPO TERMICO TPR IN ALLUMINIO Ø 47,6 Spinotto Ø 10	CYLINDER KIT TPR ALLUMINIUM Ø 47,6 Pin Ø 10	CYLINDRE COMPLET TPR EN ALUMINIUM Ø 47,6 Axe de Piston Ø 10			9921630	9921630	9921630
GRUPPO TERMICO TPR IN ALLUMINIO Ø 47,6 Spinotto Ø 12	CYLINDER KIT TPR ALLUMINIUM Ø 47,6 Pin Ø 12	CYLINDRE COMPLET TPR EN ALUMINIUM Ø 47,6 Axe de Piston Ø 12					
KIT ASPIRAZIONE COMPLETO MIKUNI TPR 360	COMPLETE INLET KIT MIKUNI TM 24 TPR 360	KIT ASPIRATION COMPLET MIKUNI TM 24 TPR 360			9930830	9930830	9930830
KIT ASPIRAZIONE COMPLETO OKO 28	COMPLETE INLET KIT OKO 28 TPR 360	KIT ASPIRATION COMPLET OKO 28 TPR 360			9931710	9931710	9931710
MAXI KIT 77 cc ALESAGGIO Ø 50 CORSA STD	MAXI KIT 77 cc Bore Ø 50 Standard stroke	MAXI KIT 77 cc ALÉSAGE Ø 50 COURSE STD					
MAXI KIT 86 cc ALESAGGIO Ø 50 CORSA 44 mm	MAXI KIT 86 cc Bore Ø 50 stroke 44 mm	MAXI KIT 86 cc ALÉSAGE Ø 50 COURSE 44 mm					
RAPPORTO ALLUNGATO secondario	SHAFT/GEARS	RAPPORT ALLONGÉ secondaire			990875P	990875P	990875P
SERIE MOLLE CONTRASTO	VARIATOR SPRINGS SET	VARIATEUR RESSORT SET			9925620	9925620	9925620
SERIE MOLLE FRIZIONE	CLUTCH SPRINGS SET	RESSORT EMBRAYAGE SET			9908240 9912740	9908240 9912740	9908240 9912740
SCARICO NARDÒ 2 omologato	EXHAUST NARDÒ 2 Approved	ÉCHAPPEMENT NARDÒ 2 homologué			9931440	9931440	9931440
SCARICO TPR GP omologato	EXHAUST TPR GP Approved	ÉCHAPPEMENT TPR GP homologué					
VALVOLA LAMELLARE TPR	REED VALVE TPR	CLAPET À LAMELLES TPR			9931620	9931620	9931620
VARIOTOP TPR c/cinghia	VARIOTOP TPR with belt	VARIOTOP TPR avec courroie			9931670	9931670	9931670
VARIOTOP TPR s/cinghia	VARIOTOP TPR with spring	VARIOTOP TPR avec ressort			9931650	9931650	9931650

YAMAHA	YAMAHA	YAMAHA	YAMAHA	YAMAHA	YAMAHA	YAMAHA	YAMAHA	YAMAHA	YAMAHA	YAMAHA	YAMAHA
NEO'S	NEO'S	NEO'S 4	NEO'S 4	NEO'S 4	NEO'S EASY	NEO'S EURO 2	RS SPY	SLIDER	WHY	WHY EURO 2	ZEST
07-12	12-16	09-10	11-12	12-15	13-13	02-02	95-98	00-02	98-05	03-05	95-92
50cc 2T AC	50cc 2T AC	50cc 4T-3V LC	50cc 4T-3V LC	50cc 4T-3V LC	50cc 2T AC	50cc 2T AC	50cc 2T AC	50cc 2T AC	50cc 2T AC	50cc 2T AC	50cc 2T AC
MY	MY	5C3	5C3	5C3	MY	MY	CW	CW	MY	MY	CY
9925910	9925910				9925910	9925910	9927900	9927900	9925910	9925910	9925910
9928320	9928320				9928320	9928320			9928320	9928320	9928320
9921790	9921790				9921790	9921790				9921790	
9923030	9923030				9923030	9923030	9923030	9923030	9923030	9923030	9923030
9930300	9930300				9930300	9930300	9930300	9930300	9930300	9930300	
9929190	9929190				9929190	9929190	9929190	9929190	9929190	9929190	9929190
9927450	9927450				9927450	9927450	9927450	9927450	9927450	9927450	
9930030	9930030				9930030	9930030	9930000	9930000	9930030	9930030	9930030
9911210	9911210				9911210	9911210			9911210	9911210	9911210
9921630	9921630	9926330	9926330	9926330	9921630	9921630	9921640	9921640	9921630	9921630	9921630
9930830	9930830				9930830	9930830			9930830	9930830	9930830
9931710	9931710				9931710	9931710			9931710	9931710	9931710
990875P	990875P				990875P	990875P	990875P	990875P			
9925620	9925620	9925620	9925620	9925620	9925620	9925620	9925620	9925620	9925620	9925620	9925620
9908240 9912740	9908240 9912740	9912740	9912740	9912740	9908240 9912740	9908240 9912740	9908240	9908240 9912740	9908240 9912740	9908240 9912740	9912740
9931440	9931440				9931440	9931440	9931450	9931450	9931440	9931440	9931440
9931620	9931620				9931620	9931620			9931620	9931620	9931620
9931670	9931670				9931670	9931670	9931670	9931670	9931670	9931670	9931690
9931650	9931650	9926130	9926130	9926130	9931650	9931650	9931650	9931650	9931650	9931650	9931650

SCOOTER 50cc
RACING

SCOOTER 50cc RACING

TOP
- performances -



YAMAHA

ZUMA

97-01

50cc 2T AC

CW

IT	EN	FR		
ALBERO MOTORE TPR CORSA STD Spinotto Ø 10	CRANKSHAFT TPR Standard stroke pin Ø10	VILEBREQUIN TPR COURSE STD Axe de piston Ø 10		9927900
ALBERO MOTORE TPR CORSA STD Spinotto Ø 12	CRANKSHAFT TPR Standard stroke pin Ø12	VILEBREQUIN TPR COURSE STD Axe de piston Ø 12		
CENTRALINA RACING	RACING CDI	Unité de contrôle RACING		
CONVERTITORE DI COPPIA	REAR VARIATOR PULLEY ASSY	POULIE SECONDAIRE		9923030
COPERCHIO INGRANAGGI	GEAR COVER	COUVERCLE ENGRENAGES		9930300
CUSCINETTI DI BANCO TPR CARBONITRURATI Serie	BEARINGS TPR Carbonitrided Series	PALIERI DE VILEBREQUIN TPR CARBONITRURÉS Jeu		9929190
FRIZIONE TPR GP REGOLABILE Patented	CLUTCH TPR GP Adjustable Patented	EMBAYAGE TPR GP RÉGLABLE Patented		9927450
GRUPPO TERMICO RACING MAGGIORATO C/TESTA (GHISA)	RACING CYLINDER KITS BIG BORE with head (CAST IRON)	CYLINDRE COMPLET RACING MAJORÉ AVEC CULASSE (FONTE)		9930000
GRUPPO TERMICO RACING 2004 C/TESTA SCOMPOSTA (GHISA)	RACING CYLINDER KITS BIG BORE without head (CAST IRON)	CYLINDRE COMPLET RACING 2004 AVEC CULASSE DÉCOMPOSÉE (FONTE)		
GRUPPO TRASFORMAZIONE DA ARIA AD ACQUA (GHISA)	CYLINDER KIT Conversion AC to LC (CAST IRON)	GROUPE TRANSFORMATION DE L'AIR À L'EAU (FONTE)		
GRUPPO TERMICO TPR IN ALLUMINIO Ø 47,6 Spinotto Ø 10	CYLINDER KIT TPR ALLUMINIUM Ø 47,6 Pin Ø 10	CYLINDRE COMPLET TPR EN ALUMINIUM Ø 47,6 Axe de Piston Ø 10		9921640
GRUPPO TERMICO TPR IN ALLUMINIO Ø 47,6 Spinotto Ø 12	CYLINDER KIT TPR ALLUMINIUM Ø 47,6 Pin Ø 12	CYLINDRE COMPLET TPR EN ALUMINIUM Ø 47,6 Axe de Piston Ø 12		
KIT ASPIRAZIONE COMPLETO MIKUNI TPR 360	COMPLETE INLET KIT MIKUNI TM 24 TPR 360	KIT ASPIRATION COMPLET MIKUNI TM 24 TPR 360		
KIT ASPIRAZIONE COMPLETO OKO 28	COMPLETE INLET KIT OKO 28 TPR 360	KIT ASPIRATION COMPLET OKO 28 TPR 360		
MAXI KIT 77 cc ALESAGGIO Ø 50 CORSA STD	MAXI KIT 77 cc Bore Ø 50 Standard stroke	MAXI KIT 77 cc ALÉSAGE Ø 50 COURSE STD		
MAXI KIT 86 cc ALESAGGIO Ø 50 CORSA 44 mm	MAXI KIT 86 cc Bore Ø 50 stroke 44 mm	MAXI KIT 86 cc ALÉSAGE Ø 50 COURSE 44 mm		
RAPPORTO ALLUNGATO secondario	SHAFT/GEARS	RAPPORT ALLONGÉ secondaire		990875P
SERIE MOLLE CONTRASTO	VARIATOR SPRINGS SET	VARIATEUR RESSORT SET		9925620
SERIE MOLLE FRIZIONE	CLUTCH SPRINGS SET	RESSORT EMBRAYAGE SET		9908240 9912740
SCARICO NARDÒ 2 omologato	EXHAUST NARDÒ 2 Approved	ÉCHAPPEMENT NARDÒ 2 homologué		9931450
SCARICO TPR GP omologato	EXHAUST TPR GP Approved	ÉCHAPPEMENT TPR GP homologué		
VALVOLA LAMELLARE TPR	REED VALVE TPR	CLAPET À LAMELLES TPR		
VARIOTOP TPR c/cinghia	VARIOTOP TPR with belt	VARIOTOP TPR avec courroie		9931670
VARIOTOP TPR s/cinghia	VARIOTOP TPR with spring	VARIOTOP TPR avec ressort		9931650



SCOOTER 50cc
RACING

MAXI SCOOTER

TOP
- performances -



APRILIA	APRILIA	APRILIA	APRILIA
ATLANTIC	ATLANTIC	ATLANTIC	ATLANTIC
03-05	03-05	03-05	10-11
125cc 4T LC	200cc 4T LC	250cc 4T LC	300cc 4T LC
	Piaggio M234M	Piaggio	Piaggio

IT	EN	FR				
ALBERO A CAMME	CAM SHAFT	ARBRE À CAMES				
ALBERO MOTORE Sel 1/Sel 2	CRANKSHAFT Sel 1/Sel 2	VILEBREQUIN Sel 1/ Sel 2				
CAMPANA FRIZIONE	CLUTCH HOUSING	CLOCHE EMBRAYAGE		FZ00377	FZ00377	FZ00395
CINGHIA DI TRASMISSIONE Bando	TRANSMISSION BELT Bando	COURROIE DE TRANSMISSION Bando		9927650		
CINGHIA DI TRASMISSIONE Mitsuboshi	TRANSMISSION BELT Mitsuboshi	COURROIE DE TRANSMISSION Mitsuboshi			9935920	9935470
CINGHIA DI TRASMISSIONE Altro	TRANSMISSION BELT Other	COURROIE DE TRANSMISSION Autres				9935470
COLLETTORE ASPIRAZIONE	INLET MANIFOLD	COLLECTEUR ASPIRATION		CT00734	CT00734	CT00735
COLLETTORE ASPIRAZIONE SX	INLET MANIFOLD LEFT	COLLECTEUR ASPIRATION GAUCHE				
COLLETTORE ASPIRAZIONE DX	INLET MANIFOLD RIGHT	COLLECTEUR ASPIRATION DROITE				
FILTRO OLIO	OIL FILTER	FILTRE À HUILE		F007515	F007515	F007515
FRIZIONE	CLUTCH	EMBRAYAGE		FZ00396	FZ00378	
GRUPPO TERMICO Standard	CYLINDER KIT Ø standard	CYLINDRE COMPLET Standard				
GRUPPO TERMICO Maggiorato	CYLINDER KIT BIG BORE	CYLINDRE COMPLET Majoré				
KIT CUSCINETTI PARAOLI DI BANCO Serie	BEARINGS AND OIL SEALS KIT	KIT PALIERS JOINTS D'HUILE DE VILEBREQUIN Jeu				
KIT REVISIONE POMPA ACQUA	WATER PUMP REPAIR KIT	KIT RÉVISION POMPE À EAU		AA00817	AA00817	AA00828
KIT TAGLIANDO	SERVICE KIT	KIT COUPON				
MASSE CENTRIFUGHE PESO ORIGINALE	ROLLER WEIGHTS Standard weight	MASSELOTTE CENTRIFUGES POIDS D'ORIGINE			9932790	9931880
MEMBRANA CARBURATORE TIPO ORIGINALE	CARBURETOR DIAPHRAGM OEM	MEMBRANE CARBURATEUR TYPE ORIGINAL				
MEMBRANA CARBURATORE ADATTABILE	CARBURETOR DIAPHRAGM Adaptable	MEMBRANE CARBURATEUR ADAPTABLE		MC12106		
MOLLE CONTRASTO VARIATORE	REAR VARIATOR SPRING	RESSORTS CONTRASTE VARIATEUR				
MOLLA A GAS PER SELIA	SEAT GAS SPRING	RESSORT À GAZ POUR SELLE				
MOTORINO D'AVVIAMENTO	STARTER ENGINE	DÉMARREUR ÉLECTRIQUE		MA00012		MA00016
PIATTELLO PORTATASSELI	VARIATOR SLIDERS	CURSEURS VARIATEUR				
POMPA BENZINA	FUEL PUMP	POMPE À ESSENCE				
PULEGGIA FISSA	FIXED SHEAVE	POULIE FIXE		PL04072		
REGOLATORE DI TENSIONE	RECTIFIER	RÉGULATEUR DE TENSION		RE00011		
RUOTA LIBERA Completa	STARTER CLUTCH SET	ROUE LIBRE Complète				
RUOTA LIBERA RL + flangia	STARTER CLUTCH + FLANGE	ROUE LIBRE RL + flasque				RL00021
RUOTA LIBERA RL nuda	STARTER CLUTCH	ROUE LIBRE RL nue				
RUOTA LIBERA Ingranaggio	STARTER CLUTCH GEAR	ROUE LIBRE Engrenage		RL00022	RL00022	RL00023
RUOTA LIBERA Flangia	STARTER CLUTCH FLANGE	ROUE LIBRE Flasque				
SERIE DISCHI FRIZIONE	CLUTCH PLATES KIT	JEU DISQUES EMBRAYAGE				
STATORE	STATOR	STATOR				
TASSELLI TRAINO	VARIATOR SLIDERS	CURSEURS VARIATEUR				
VARIATORE VARIOTOP TPR	VARIOTOP TPR	VARIOTOP TPR		9923600	9923650	9923650

APRILIA	APRILIA	APRILIA	APRILIA	APRILIA	APRILIA	APRILIA	APRILIA	APRILIA	APRILIA	APRILIA	APRILIA
ATLANTIC	ATLANTIC ARRECIFE	ATLANTIC ARRECIFE	ATLANTIC ARRECIFE	ATLANTIC ARRECIFE	ATLANTIC ARRECIFE	ATLANTIC EU3	ATLANTIC EU3	ATLANTIC EU3	ATLANTIC SPRINT	ATLANTIC SPRINT	LEONARDO
01-04	03-05	03-05	03-05	05-08	05-08	06-08	10-12	06-08	05-08	05-08	96-98
500cc 4T LC	125cc 4T LC	200cc 4T LC	250cc 4T LC	400cc 4T LC	500cc 4T LC	125cc 4T LC	125cc 4T LC	250cc 4T LC	400cc 4T LC	500cc 4T LC	125cc 4T LC
		Piaggio M234M	Piaggio M237M	Piaggio M348M	Piaggio M273M	Piaggio	Piaggio	Piaggio M237M	Piaggio M348M	Piaggio M273M	Rotax
						IM070701 IM070702	IM070701 IM070702				
FZ00384	FZ00377	FZ00377				FZ00395	FZ00395	FZ00395			
	9927650			9927630	9927630	9927650	9927650		9927630	9927630	9915220
9935460								9935470			9935660
F007524	F007515	F007515	F007515	F007524	F007524	F007515	F007515	F007515	F007524	F007524	F007516
FZ00383	FZ00378	FZ00378	FZ00382			FZ00396	FZ00396	FZ00382			
	AA00817	AA00817				AA00826	AA00826	AA00828			AA00811
9922330								9931880			9916260
						MC12106	MC12106				
9926780				9926780	9926780				9926780	9926780	
MA00030						MA00012	MA00012	MA00016	MA00030	MA00030	MA00022
						PL04072	PL04072				
RE00004						RE00011	RE00011	RE00004	RE00004	RE00004	
RL00021		RL00021	RL00021	RL00021	RL00021	RL00041		RL00041	RL00021	RL00021	
											RL00005
RL00023				RL00023	RL00023	RL00022	RL00022	RL00023	RL00023	RL00023	RL00013
											RL00014
ST00005						ST00023		ST00023	ST00005	ST00005	
9923250	9923600	9923650	9923650	9923250	9923250	9923600	9923600	9923650	9923250	9923250	

MAXI SCOOTER

TOP
- performances -



APRILIA	APRILIA	APRILIA	APRILIA
LEONARDO	LEONARDO	LEONARDO	LEONARDO
99-02	96-98	99-02	99-01
125cc 4T LC	150cc 4T LC	150cc 4T LC	250cc 4T LC
Rotax	Rotax	Rotax	Minarelli YP

IT	EN	FR				
ALBERO A CAMME	CAM SHAFT	ARBRE À CAMES				
ALBERO MOTORE Sel 1/Sel 2	CRANKSHAFT Sel 1/Sel 2	VILEBREQUIN Sél 1/ Sél 2				IM07054
CAMPANA FRIZIONE	CLUTCH HOUSING	CLOCHE EMBRAYAGE				
CINGHIA DI TRASMISSIONE Bando	TRANSMISSION BELT Bando	COURROIE DE TRANSMISSION Bando		9915220	9915220	9915220 9915800
CINGHIA DI TRASMISSIONE Mitsuboshi	TRANSMISSION BELT Mitsuboshi	COURROIE DE TRANSMISSION Mitsuboshi		9935660	9935660	9935660 9935710
CINGHIA DI TRASMISSIONE Altro	TRANSMISSION BELT Other	COURROIE DE TRANSMISSION Autres				
COLLETTORE ASPIRAZIONE	INLET MANIFOLD	COLLECTEUR ASPIRATION				
COLLETTORE ASPIRAZIONE SX	INLET MANIFOLD LEFT	COLLECTEUR ASPIRATION GAUCHE				
COLLETTORE ASPIRAZIONE DX	INLET MANIFOLD RIGHT	COLLECTEUR ASPIRATION DROITE				
FILTRO OLIO	OIL FILTER	FILTRE À HUILE		F007516	F007516	F007516
FRIZIONE	CLUTCH	EMBRAYAGE				FZ00401
GRUPPO TERMICO Standard	CYLINDER KIT Ø standard	CYLINDRE COMPLET Standard				9926850
GRUPPO TERMICO Maggiorato	CYLINDER KIT BIG BORE	CYLINDRE COMPLET Majoré				
KIT CUSCINETTI PARAOLI DI BANCO Serie	BEARINGS AND OIL SEALS KIT	KIT PALIERS JOINTS D'HUILE DE VILEBREQUIN Jeu				KK01007
KIT REVISIONE POMPA ACQUA	WATER PUMP REPAIR KIT	KIT RÉVISION POMPE À EAU		AA00810	AA00811	AA00810 AA00806
KIT TAGLIANDO	SERVICE KIT	KIT COUPON				
MASSE CENTRIFUGHE PESO ORIGINALE	ROLLER WEIGHTS Standard weight	MASSELOTTE CENTRIFUGES POIDS D'ORIGINE		9916260	9915310	9918020
MEMBRANA CARBURATORE TIPO ORIGINALE	CARBURETOR DIAPHRAGM OEM	MEMBRANE CARBURATEUR TYPE ORIGINAL				MC12001
MEMBRANA CARBURATORE ADATTABILE	CARBURETOR DIAPHRAGM Adaptable	MEMBRANE CARBURATEUR ADAPTABLE				MC12101
MOLLE CONTRASTO VARIATORE	REAR VARIATOR SPRING	RESSORTS CONTRASTE VARIATEUR				9929870
MOLLA A GAS PER SELIA	SEAT GAS SPRING	RESSORT À GAZ POUR SELLE				
MOTORINO D'AVVIAMENTO	STARTER ENGINE	DÉMARREUR ÉLECTRIQUE		MA00022	MA00022	MA00022 MA00010
PIATTELLO PORTATASSELI	VARIATOR SLIDERS	CURSEURS VARIATEUR				PL04066
POMPA BENZINA	FUEL PUMP	POMPE À ESSENCE				
PULEGGIA FISSA	FIXED SHEAVE	POULIE FIXE				PL04075
REGOLATORE DI TENSIONE	RECTIFIER	RÉGULATEUR DE TENSION				
RUOTA LIBERA Completa	STARTER CLUTCH SET	ROUE LIBRE Complète				
RUOTA LIBERA RL + flangia	STARTER CLUTCH + FLANGE	ROUE LIBRE RL + flasque				RL00010
RUOTA LIBERA RL nuda	STARTER CLUTCH	ROUE LIBRE RL nue		RL00005	RL00005	RL00005
RUOTA LIBERA Ingranaggio	STARTER CLUTCH GEAR	ROUE LIBRE Engrenage		RL00013	RL00013	RL00013 RL00011
RUOTA LIBERA Flangia	STARTER CLUTCH FLANGE	ROUE LIBRE Flasque		RL00014	RL00014	RL00014
SERIE DISCHI FRIZIONE	CLUTCH PLATES KIT	JEU DISQUES EMBRAYAGE				
STATORE	STATOR	STATOR				
TASSELLI TRAINO	VARIATOR SLIDERS	CURSEURS VARIATEUR				
VARIATORE VARIOTOP TPR	VARIOTOP TPR	VARIOTOP TPR				9931790

APRILIA	APRILIA	APRILIA	APRILIA	APRILIA	APRILIA	APRILIA	APRILIA	APRILIA	APRILIA	APRILIA	APRILIA
LEONARDO	LEONARDO	LEONARDO ST	LEONARDO ST	MOJITO	MOJITO	MOJITO	MOJITO RETRO' CUSTOM	SCARABEO	SCARABEO	SCARABEO	SCARABEO
02-04	02-04	03-04	01-01	03-07	08-08	03-07	99-01	99-03	03-03	04-06	99-03
250cc 4T LC	300cc 4T LC	125cc 4T LC	250cc 4T LC	125cc 4T AC	125cc 4T AC	150cc 4T AC	125cc 4T AC	125cc 4T LC	125cc 4T LC	125cc 4T LC	150cc 4T LC
Minarelli YP	Minarelli YP	Rotax	Minarelli YP	Leader	Piaggio			Rotax	Piaggio	Piaggio	Rotax
IM07054			IM07054	IM070701 IM070702	IM070701 IM070702						
FZ00397	FZ00397			FZ00395	FZ00395	FZ00395			FZ00395	FZ00377	
9915800	9915800	9915220	9915800	9927650	9927650	9927650		9915220	9928540	9928540	9915220
9935710	9935710	9935660	9935710				9935430	9935660			9935660
				CT00736	CT00736				CT00734	CT00734	
		F007516		F007515	F007515	F007515	F007514	F007516	F007515	F007515	F007516
FZ00388	FZ00388		FZ00401	FZ00396	FZ00396				FZ00396	FZ00396	
9926850			9926850								
KK01007	KK01007		KK01007								
AA00806	AA00806	AA00810	AA00806					AA00810		AA00817	AA00810
9918020	9918020	9916260	9918020					9916260			9915310
MC12001	MC12001		MC12001	MC12002	MC12002	MC12002					
MC12101	MC12101		MC12101	MC12107	MC12107					MC12106	
9929870			9929870								
MA00010	MA00010	MA00022	MA00010	MA00012	MA00012			MA00022	MA00012	MA00012	MA00022
PL04066			PL04066								
PL04075			PL04075	PL04072	PL04072	PL04072			PL04072	PL04072	
				RE00011	RE00011	RE00011	RE00012		RE00011	RE00011	
RL00010	RL00010		RL00010								
		RL00005						RL00005			RL00005
RL00011	RL00011	RL00013	RL00011	RL00022	RL00022	RL00022		RL00013	RL00022	RL00022	RL00013
		RL00014						RL00014			RL00014
9931790			9931790	9923600	9923600	9923600			9923600	9923600	

MAXI SCOOTER

TOP
- performances -



APRILIA APRILIA APRILIA APRILIA

SCARABEO	SCARABEO	SCARABEO	SCARABEO
04-06	01-03	03-03	04-06
150cc 4T LC	200cc 4T LC	200cc 4T LC	250cc 4T LC
Piaggio	Rotax	Piaggio	Piaggio M258M

IT	EN	FR				
ALBERO A CAMME	CAM SHAFT	ARBRE À CAMES				
ALBERO MOTORE Sel 1/Sel 2	CRANKSHAFT Sel 1/Sel 2	VILEBREQUIN Sel 1/ Sel 2				
CAMPANA FRIZIONE	CLUTCH HOUSING	CLOCHE EMBRAYAGE				FZ00377
CINGHIA DI TRASMISSIONE Bando	TRANSMISSION BELT Bando	COURROIE DE TRANSMISSION Bando		9928540		9927640
CINGHIA DI TRASMISSIONE Mitsuboshi	TRANSMISSION BELT Mitsuboshi	COURROIE DE TRANSMISSION Mitsuboshi			9935450	
CINGHIA DI TRASMISSIONE Altro	TRANSMISSION BELT Other	COURROIE DE TRANSMISSION Autres				
COLLETTORE ASPIRAZIONE	INLET MANIFOLD	COLLECTEUR ASPIRATION				CT00735
COLLETTORE ASPIRAZIONE SX	INLET MANIFOLD LEFT	COLLECTEUR ASPIRATION GAUCHE				
COLLETTORE ASPIRAZIONE DX	INLET MANIFOLD RIGHT	COLLECTEUR ASPIRATION DROITE				
FILTRO OLIO	OIL FILTER	FILTRE À HUILE		F007515	F007516	F007515
FRIZIONE	CLUTCH	EMBAYAGE				FZ00382
GRUPPO TERMICO Standard	CYLINDER KIT Ø standard	CYLINDRE COMPLET Standard				
GRUPPO TERMICO Maggiorato	CYLINDER KIT BIG BORE	CYLINDRE COMPLET Majoré				
KIT CUSCINETTI PARAOLI DI BANCO Serie	BEARINGS AND OIL SEALS KIT	KIT PALIERS JOINTS D'HUILE DE VILEBREQUIN Jeu				
KIT REVISIONE POMPA ACQUA	WATER PUMP REPAIR KIT	KIT RÉVISION POMPE À EAU		AA00817		AA00828
KIT TAGLIANDO	SERVICE KIT	KIT COUPON				
MASSE CENTRIFUGHE PESO ORIGINALE	ROLLER WEIGHTS Standard weight	MASSELOTTE CENTRIFUGES POIDS D'ORIGINE			9932790	
MEMBRANA CARBURATORE TIPO ORIGINALE	CARBURETOR DIAPHRAGM OEM	MEMBRANE CARBURATEUR TYPE ORIGINAL				
MEMBRANA CARBURATORE ADATTABILE	CARBURETOR DIAPHRAGM Adaptable	MEMBRANE CARBURATEUR ADAPTABLE				
MOLLE CONTRASTO VARIATORE	REAR VARIATOR SPRING	RESSORTS CONTRASTE VARIATEUR				
MOLLA A GAS PER SELIA	SEAT GAS SPRING	RESSORT À GAZ POUR SELLE				
MOTORINO D'AVVIAMENTO	STARTER ENGINE	DÉMARREUR ÉLECTRIQUE			MA00022	MA00016
PIATTELLO PORTATASSELI	VARIATOR SLIDERS	CURSEURS VARIATEUR				
POMPA BENZINA	FUEL PUMP	POMPE À ESSENCE				
PULEGGIA FISSA	FIXED SHEAVE	POULIE FIXE		PL04072		
REGOLATORE DI TENSIONE	RECTIFIER	RÉGULATEUR DE TENSION		RE00011		
RUOTA LIBERA Completa	STARTER CLUTCH SET	ROUE LIBRE Complète				
RUOTA LIBERA RL + flangia	STARTER CLUTCH + FLANGE	ROUE LIBRE RL + flasque				
RUOTA LIBERA RL nuda	STARTER CLUTCH	ROUE LIBRE RL nue			RL00005	
RUOTA LIBERA Ingranaggio	STARTER CLUTCH GEAR	ROUE LIBRE Engrenage		RL00022	RL00013	RL00022
RUOTA LIBERA Flangia	STARTER CLUTCH FLANGE	ROUE LIBRE Flasque			RL00014	
SERIE DISCHI FRIZIONE	CLUTCH PLATES KIT	JEU DISQUES EMBRAYAGE				
STATORE	STATOR	STATOR				
TASSELLI TRAINO	VARIATOR SLIDERS	CURSEURS VARIATEUR				
VARIATORE VARIOTOP TPR	VARIOTOP TPR	VARIOTOP TPR		9923600		9923650

APRILIA	APRILIA	APRILIA	APRILIA	APRILIA	APRILIA	APRILIA	APRILIA	APRILIA	APRILIA	APRILIA	APRILIA
SCARABEO	SCARABEO EU3	SCARABEO EU3	SCARABEO IE LIGHT	SCARABEO IE LIGHT	SCARABEO IE LIGHT	SCARABEO LIGHT	SCARABEO LIGHT	SCARABEO LIGHT	SCARABEO LIGHT	SCARABEO LIGHT	SCARABEO LIGHT
03-06	06-07	06-06	09-10	11-12	11-12	07-08	07-08	06-08	09-10	06-08	06-08
500cc 4T LC	125cc 4T LC	200cc 4T LC	125cc 4T LC	125cc 4T LC	200cc 4T LC	125cc 4T LC	200cc 4T LC	250cc 4T LC	300cc 4T LC	400cc 4T LC	500cc 4T LC
Piaggio	Piaggio	Piaggio	Motore Aprilia	Motore Aprilia	Motore Aprilia	Aprilia BA03	Aprilia CA03	Piaggio	Piaggio	Piaggio	Piaggio
	IM070701 IM070702										
FZ00384	FZ00395							FZ00395	FZ00395		
9927630	9928540							9927640	9927640	9927630	9927630
		9935450	9935220	9935220	9935220	9935220					9935500
F007524	F007515	F007515						F007515	F007515	F007524	F007524
FZ00383	FZ00396										
	AA00826							AA00828	AA00828	AA00824	AA00824
									TG00102		
9922330		9932790						9931880	9931880	9924530	9935990
	MC12106										
9926780										9926780	9926780
MA00030	MA00012							MA00016	MA00016	MA00030	MA00030
	PL04072		PL04061	PL04061	PL04061	PL04061					
RE00004	RE00011							RE00004	RE00004	RE00004	RE00004
RL00021								RL00041	RL00021	RL00021	RL00021
RL00023	RL00022	RL00022						RL00023	RL00023	RL00023	RL00023
ST00005								ST00023	ST00023	ST00005	ST00005
9923250	9923600	9923650	9923600	9923600	9923600	9923600	9923650	9923650	9923650	9923250	9923250

MAXI SCOOTER

MAXI SCOOTER

TOP
- performances -



APRILIA	APRILIA	APRILIA	APRILIA
SPORT CITY	SPORT CITY	SPORT CITY CUBE	SPORT CITY CUBE
04-06	04-06	08-10	08-10
125cc 4T LC	200cc 4T LC	125cc 4T LC	200cc 4T LC
Piaggio M281M		Piaggio	Piaggio

IT	EN	FR				
ALBERO A CAMME	CAM SHAFT	ARBRE À CAMES				
ALBERO MOTORE Sel 1/Sel 2	CRANKSHAFT Sel 1/Sel 2	VILEBREQUIN Sél 1/ Sél 2				IM070701 IM070702
CAMPANA FRIZIONE	CLUTCH HOUSING	CLOCHE EMBRAYAGE		FZ00377	FZ00377	FZ00395 FZ00395
CINGHIA DI TRASMISSIONE Bando	TRANSMISSION BELT Bando	COURROIE DE TRANSMISSION Bando		9928540		9928540
CINGHIA DI TRASMISSIONE Mitsuboshi	TRANSMISSION BELT Mitsuboshi	COURROIE DE TRANSMISSION Mitsuboshi				9935450
CINGHIA DI TRASMISSIONE Altro	TRANSMISSION BELT Other	COURROIE DE TRANSMISSION Autres				
COLLETTORE ASPIRAZIONE	INLET MANIFOLD	COLLECTEUR ASPIRATION		CT00734		
COLLETTORE ASPIRAZIONE SX	INLET MANIFOLD LEFT	COLLECTEUR ASPIRATION GAUCHE				
COLLETTORE ASPIRAZIONE DX	INLET MANIFOLD RIGHT	COLLECTEUR ASPIRATION DROITE				
FILTRO OLIO	OIL FILTER	FILTRE À HUILE		F007515	F007515	F007515 F007515
FRIZIONE	CLUTCH	EMBAYAGE		FZ00396	FZ00378	FZ00396
GRUPPO TERMICO Standard	CYLINDER KIT Ø standard	CYLINDRE COMPLET Standard				
GRUPPO TERMICO Maggiorato	CYLINDER KIT BIG BORE	CYLINDRE COMPLET Majoré				
KIT CUSCINETTI PARAOLI DI BANCO Serie	BEARINGS AND OIL SEALS KIT	KIT PALIERS JOINTS D'HUILE DE VILEBREQUIN Jeu				
KIT REVISIONE POMPA ACQUA	WATER PUMP REPAIR KIT	KIT RÉVISION POMPE À EAU		AA00817	AA00817	AA00826
KIT TAGLIANDO	SERVICE KIT	KIT COUPON				
MASSE CENTRIFUGHE PESO ORIGINALE	ROLLER WEIGHTS Standard weight	MASSELOTTE CENTRIFUGES POIDS D'ORIGINE			9932790	
MEMBRANA CARBURATORE TIPO ORIGINALE	CARBURETOR DIAPHRAGM OEM	MEMBRANE CARBURATEUR TYPE ORIGINAL				
MEMBRANA CARBURATORE ADATTABILE	CARBURETOR DIAPHRAGM Adaptable	MEMBRANE CARBURATEUR ADAPTABLE		MC12106		MC12106
MOLLE CONTRASTO VARIATORE	REAR VARIATOR SPRING	RESSORTS CONTRASTE VARIATEUR				
MOLLA A GAS PER SELIA	SEAT GAS SPRING	RESSORT À GAZ POUR SELLE				
MOTORINO D'AVVIAMENTO	STARTER ENGINE	DÉMARREUR ÉLECTRIQUE		MA00012		MA00012
PIATTELLO PORTATASSELI	VARIATOR SLIDERS	CURSEURS VARIATEUR				
POMPA BENZINA	FUEL PUMP	POMPE À ESSENCE				
PULEGGIA FISSA	FIXED SHEAVE	POULIE FIXE		PL04072		PL04072
REGOLATORE DI TENSIONE	RECTIFIER	RÉGULATEUR DE TENSION		RE00011		RE00011
RUOTA LIBERA Completa	STARTER CLUTCH SET	ROUE LIBRE Complète				
RUOTA LIBERA RL + flangia	STARTER CLUTCH + FLANGE	ROUE LIBRE RL + flasque				
RUOTA LIBERA RL nuda	STARTER CLUTCH	ROUE LIBRE RL nue				
RUOTA LIBERA Ingranaggio	STARTER CLUTCH GEAR	ROUE LIBRE Engrenage		RL00022	RL00022	RL00022 RL00022
RUOTA LIBERA Flangia	STARTER CLUTCH FLANGE	ROUE LIBRE Flasque				
SERIE DISCHI FRIZIONE	CLUTCH PLATES KIT	JEU DISQUES EMBRAYAGE				
STATORE	STATOR	STATOR				
TASSELLI TRAINO	VARIATOR SLIDERS	CURSEURS VARIATEUR				
VARIATORE VARIOTOP TPR	VARIOTOP TPR	VARIOTOP TPR		9923600	9923650	9923600

APRILIA	APRILIA	APRILIA	APRILIA	APRILIA	APRILIA	APRILIA	APRILIA	APRILIA	APRILIA	APRILIA	APRILIA
SPORT CITY CUBE	SPORT CITY CUBE	SPORT CITY EU3	SPORT CITY EU3	SPORT CITY EU3	SPORT CITY ONE 4T EU3	SPORT CITY STREET	SPORT CITY STREET	SR	SR	SR MAX	SR MAX
08-12	08-10	06-08	06-08	06-08	08-11	12-12	12-12	99-01	99-01	11-14	11-14
250cc 4T LC	300cc 4T LC	125cc 4T LC	200cc 4T LC	250cc 4T LC	125cc 4T AC	125cc 4T LC	300cc 4T-4V LC	125cc 2T AC	150cc 2T AC	125cc 4T LC	125cc 4T-4V LC
Piaggio	Leader M28LM	Piaggio	Piaggio M288M	Piaggio M288M	Leader M38AM	Piaggio	Piaggio	Piaggio	Piaggio	Piaggio	Piaggio
		IM070701 IM070702			IM070701 IM070702						
FZ00395	FZ00395	FZ00395	FZ00395	FZ00395	FZ00395	FZ00395	FZ00395				
9927640	9927640	9928540		9927640	9927650	9928540	9927640	9915350	9915350	9927650	
			9935450					9935670	9935670		
					CT00736			CT00728	CT00728		
F007515	F007515	F007515	F007515	F007515	F007515	F007515	F007515			F007515	
		FZ00396		FZ00382	FZ00418						
		AA00826				AA00826	AA00828				
TG00102							TG00102				
9931880			9932790	9931880			9931880				
		MC12106			MC12107	MC12106					
MA00016		MA00012		MA00016	MA00012	MA00012	MA00016			MA00016	
		PL04072			PL04072	PL04072					
RE00004		RE00011		RE00004	RE00011	RE00011	RE00004			RE00004	
RL00041	RL00021	RL00041					RL00021			RL00041	
RL00023	RL00023	RL00022	RL00022	RL00023	RL00022	RL00022	RL00023			RL00023	
ST00023		ST00023									ST00023
9923650	9923650	9923600	9923650	9923650	9923600	9923600	9923650			9923600	

MAXI SCOOTER

MAXI SCOOTER

TOP
- performances -



APRILIA	APRILIA	APRILIA	BENELLI
SR MAX	SR MOTARD	SRV - SRV ABS ATC	ADIVA
11-14	12-14	12-14	01-02
300cc 4T LC	125cc 4T-2V AC	850cc 4T-4V LC	125cc 4T AC
Piaggio	Piaggio		Leader

IT	EN	FR				
ALBERO A CAMME	CAM SHAFT	ARBRE À CAMES				
ALBERO MOTORE Sel 1/Sel 2	CRANKSHAFT Sel 1/Sel 2	VILEBREQUIN Sél 1/ Sél 2				
CAMPANA FRIZIONE	CLUTCH HOUSING	CLOCHE EMBRAYAGE			FZ00395	
CINGHIA DI TRASMISSIONE Bando	TRANSMISSION BELT Bando	COURROIE DE TRANSMISSION Bando			9927650	9927650
CINGHIA DI TRASMISSIONE Mitsuboshi	TRANSMISSION BELT Mitsuboshi	COURROIE DE TRANSMISSION Mitsuboshi		9935470		9935930
CINGHIA DI TRASMISSIONE Altro	TRANSMISSION BELT Other	COURROIE DE TRANSMISSION Autres				
COLLETTORE ASPIRAZIONE	INLET MANIFOLD	COLLECTEUR ASPIRATION			CT00736	
COLLETTORE ASPIRAZIONE SX	INLET MANIFOLD LEFT	COLLECTEUR ASPIRATION GAUCHE				
COLLETTORE ASPIRAZIONE DX	INLET MANIFOLD RIGHT	COLLECTEUR ASPIRATION DROITE				
FILTRO OLIO	OIL FILTER	FILTRE À HUILE		F007515	F007515	F007515
FRIZIONE	CLUTCH	EMBAYAGE			FZ00418	
GRUPPO TERMICO Standard	CYLINDER KIT Ø standard	CYLINDRE COMPLET Standard				
GRUPPO TERMICO Maggiorato	CYLINDER KIT BIG BORE	CYLINDRE COMPLET Majoré				
KIT CUSCINETTI PARAOLI DI BANCO Serie	BEARINGS AND OIL SEALS KIT	KIT PALIERS JOINTS D'HUILE DE VILEBREQUIN Jeu				
KIT REVISIONE POMPA ACQUA	WATER PUMP REPAIR KIT	KIT RÉVISION POMPE À EAU		AA00828		
KIT TAGLIANDO	SERVICE KIT	KIT COUPON				
MASSE CENTRIFUGHE PESO ORIGINALE	ROLLER WEIGHTS Standard weight	MASSELOTTE CENTRIFUGES POIDS D'ORIGINE		9931880		
MEMBRANA CARBURATORE TIPO ORIGINALE	CARBURETOR DIAPHRAGM OEM	MEMBRANE CARBURATEUR TYPE ORIGINAL			MC12107	
MEMBRANA CARBURATORE ADATTABILE	CARBURETOR DIAPHRAGM Adaptable	MEMBRANE CARBURATEUR ADAPTABLE				
MOLLE CONTRASTO VARIATORE	REAR VARIATOR SPRING	RESSORTS CONTRASTE VARIATEUR				
MOLLA A GAS PER SELIA	SEAT GAS SPRING	RESSORT À GAZ POUR SELLE				
MOTORINO D'AVVIAMENTO	STARTER ENGINE	DÉMARREUR ÉLECTRIQUE		MA00016	MA00012	
PIATTELLO PORTATASSELI	VARIATOR SLIDERS	CURSEURS VARIATEUR				
POMPA BENZINA	FUEL PUMP	POMPE À ESSENCE				
PULEGGIA FISSA	FIXED SHEAVE	POULIE FIXE			PL04072	
REGOLATORE DI TENSIONE	RECTIFIER	RÉGULATEUR DE TENSION		RE00004	RE00012	
RUOTA LIBERA Completa	STARTER CLUTCH SET	ROUE LIBRE Complète				
RUOTA LIBERA RL + flangia	STARTER CLUTCH + FLANGE	ROUE LIBRE RL + flasque		RL00021		
RUOTA LIBERA RL nuda	STARTER CLUTCH	ROUE LIBRE RL nue				
RUOTA LIBERA Ingranaggio	STARTER CLUTCH GEAR	ROUE LIBRE Engrenage		RL00023	RL00022	
RUOTA LIBERA Flangia	STARTER CLUTCH FLANGE	ROUE LIBRE Flasque				
SERIE DISCHI FRIZIONE	CLUTCH PLATES KIT	JEU DISQUES EMBRAYAGE				
STATORE	STATOR	STATOR				
TASSELLI TRAINO	VARIATOR SLIDERS	CURSEURS VARIATEUR				
VARIATORE VARIOTOP TPR	VARIOTOP TPR	VARIOTOP TPR		9923650	9923600	9923600

BENELLI	BENELLI	BENELLI	BENELLI	BENELLI	BENELLI	BENELLI	BENELLI	BENELLI	BETA	BETA	BMW
ADIVA	ADIVA EU2	VELVET	VELVET	VELVET	VELVET	VELVET DUSK	VELVET TOURING	VELVET TOURING	EIKON	EIKON	BMW C 600 SPORT [K18]
01-02	06-08	99-01	99-01	99-01	02-03	03-04	02-03	02-03	00-02	00-02	11-15
150cc 4T AC	250cc 4T LC	125cc 4T LC	150cc 4T LC	250cc 4T LC	250cc 4T LC	400cc 4T LC	125cc 4T LC	150cc 4T LC	125cc 4T LC	150cc 4T LC	650cc 4T LC
Leader	Leader	Minarelli YP	Minarelli YP	Minarelli YP	Minarelli YP	Morini	Minarelli YP	Minarelli YP			
		IM07045		IM07054	IM07054						
9927650		9915380	9915380	9915800	9915800		9915380	9915380	9915220	9915220	
		9935700	9935700	9935710	9935710		9935700	9935700	9935660	9935660	9935230
		CT00730	CT00730								
F007515	F007515						F007510				
				9926850	9926850						
		9929380	9929380								
		KK01010	KK01010	KK01007	KK01007						
		AA00805	AA00805	AA00806	AA00806						AA00839
		9915270		9918020	9918020	9922390			9916710	9916710	
				MC12001	MC12001						
		MC12100	MC12100	MC12101	MC12101						
		9929170	9929170	9929870	9929870						
		MA00017	MA00017	MA00010	MA00010		MA00017	MA00017			
				PL04066	PL04066						
				PL04075	PL04075						
		RL00002	RL00002	RL00010	RL00010						
				RL00011	RL00011						
9923600	9923650	9923550	9923550	9931790	9931790						

MAXI SCOOTER

MAXI SCOOTER

TOP
- performances -



BMW	BMW	BMW	BMW
BMW C 650 GT 2016 [K19]	BMW C 650 GT [K19]	BMW C 650 SPORT 2016 [K18]	C1
16-16	11-15	16-16	00-03
650cc 4T LC	650cc 4T LC	650cc 4T LC	125cc 4T LC
			Tipo Rotax

IT	EN	FR				
ALBERO A CAMME	CAM SHAFT	ARBRE À CAMES				
ALBERO MOTORE Sel 1/Sel 2	CRANKSHAFT Sel 1/Sel 2	VILEBREQUIN Sel 1/ Sel 2				
CAMPANA FRIZIONE	CLUTCH HOUSING	CLOCHE EMBRAYAGE				
CINGHIA DI TRASMISSIONE Bando	TRANSMISSION BELT Bando	COURROIE DE TRANSMISSION Bando				9915220
CINGHIA DI TRASMISSIONE Mitsuboshi	TRANSMISSION BELT Mitsuboshi	COURROIE DE TRANSMISSION Mitsuboshi		9935230	9935230	9935660
CINGHIA DI TRASMISSIONE Altro	TRANSMISSION BELT Other	COURROIE DE TRANSMISSION Autres				
COLLETTORE ASPIRAZIONE	INLET MANIFOLD	COLLECTEUR ASPIRATION				
COLLETTORE ASPIRAZIONE SX	INLET MANIFOLD LEFT	COLLECTEUR ASPIRATION GAUCHE				
COLLETTORE ASPIRAZIONE DX	INLET MANIFOLD RIGHT	COLLECTEUR ASPIRATION DROITE				
FILTRO OLIO	OIL FILTER	FILTRE À HUILE				F007516
FRIZIONE	CLUTCH	EMBRAYAGE				
GRUPPO TERMICO Standard	CYLINDER KIT Ø standard	CYLINDRE COMPLET Standard				
GRUPPO TERMICO Maggiorato	CYLINDER KIT BIG BORE	CYLINDRE COMPLET Majoré				
KIT CUSCINETTI PARAOLI DI BANCO Serie	BEARINGS AND OIL SEALS KIT	KIT PALIERS JOINTS D'HUILE DE VILEBREQUIN Jeu				
KIT REVISIONE POMPA ACQUA	WATER PUMP REPAIR KIT	KIT RÉVISION POMPE À EAU		AA00839	AA00839	AA00839 AA00810
KIT TAGLIANDO	SERVICE KIT	KIT COUPON				
MASSE CENTRIFUGHE PESO ORIGINALE	ROLLER WEIGHTS Standard weight	MASSELOTTE CENTRIFUGES POIDS D'ORIGINE				
MEMBRANA CARBURATORE TIPO ORIGINALE	CARBURETOR DIAPHRAGM OEM	MEMBRANE CARBURATEUR TYPE ORIGINAL				
MEMBRANA CARBURATORE ADATTABILE	CARBURETOR DIAPHRAGM Adaptable	MEMBRANE CARBURATEUR ADAPTABLE				
MOLLE CONTRASTO VARIATORE	REAR VARIATOR SPRING	RESSORTS CONTRASTE VARIATEUR				
MOLLA A GAS PER SELIA	SEAT GAS SPRING	RESSORT À GAZ POUR SELLE				
MOTORINO D'AVVIAMENTO	STARTER ENGINE	DÉMARREUR ÉLECTRIQUE				
PIATTELLO PORTATASSELI	VARIATOR SLIDERS	CURSEURS VARIATEUR				
POMPA BENZINA	FUEL PUMP	POMPE À ESSENCE				
PULEGGIA FISSA	FIXED SHEAVE	POULIE FIXE				
REGOLATORE DI TENSIONE	RECTIFIER	RÉGULATEUR DE TENSION				
RUOTA LIBERA Completa	STARTER CLUTCH SET	ROUE LIBRE Complète				
RUOTA LIBERA RL + flangia	STARTER CLUTCH + FLANGE	ROUE LIBRE RL + flasque				
RUOTA LIBERA RL nuda	STARTER CLUTCH	ROUE LIBRE RL nue				RL00005
RUOTA LIBERA Ingranaggio	STARTER CLUTCH GEAR	ROUE LIBRE Engrenage				RL00013
RUOTA LIBERA Flangia	STARTER CLUTCH FLANGE	ROUE LIBRE Flasque				RL00014
SERIE DISCHI FRIZIONE	CLUTCH PLATES KIT	JEU DISQUES EMBRAYAGE				
STATORE	STATOR	STATOR				
TASSELLI TRAINO	VARIATOR SLIDERS	CURSEURS VARIATEUR				
VARIATORE VARIOTOP TPR	VARIOTOP TPR	VARIOTOP TPR		9934100		9934100

BMW	DERBI	DERBI	DERBI	DERBI	DERBI	DERBI	DERBI	DERBI	DERBI	DERBI	DERBI
C1	BOULEVARD	BOULEVARD	BOULEVARD	BOULEVARD	BOULEVARD 4T E3	BOULEVARD 4T EU3	BOULEVARD EU2	BOULEVARD EU2	BOULEVARD EU3	GP1	GP1 EU 2
02-03	02-02	03-04	02-02	03-04	10-10	08-12	04-07	05-06	04-07	06-07	06-06
200cc 4T LC	125cc 4T AC	125cc 4T AC	150cc 4T AC	150cc 4T AC	150cc 4T AC	125cc 4T AC	125cc 4T AC	200cc 4T AC	150cc 4T AC	250cc 4T LC	125cc 4T LC
Tipo Rotax	Leader	Piaggio	Leader	Piaggio	Piaggio	Piaggio	Piaggio	Piaggio M387M	Piaggio	Piaggio	
					IM070701 IM070702	IM070701 IM070702	IM070701 IM070702		IM070701 IM070702		IM070701 IM070702
	FZ00377	FZ00377	FZ00377	FZ00377		FZ00395	FZ00377	FZ00395	FZ00377	FZ00395	FZ00377
9915220	9927650	9927650	9927650	9927650	9927650	9927650	9927650		9927650		9927650
9935660								9935920		9935470	
	CT00740	CT00736	CT00740	CT00736	CT00736	CT00736	CT00736	CT00736	CT00736	CT00735	CT00735
F007516	F007515	F007515	F007515	F007515	F007515	F007515	F007515	F007515	F007515	F007515	F007515
	FZ00396	FZ00396	FZ00396	FZ00396	FZ00418	FZ00418	FZ00396		FZ00396	FZ00382	FZ00396
											AA00826
								9932790			
				MC12002			MC12002				
					MC12107	MC12107	MC12107	MC12107			MC12106
	MA00012	MA00012	MA00012	MA00012	MA00012	MA00012	MA00012	MA00012	MA00012	MA00016	MA00012
	PL04060 PL04072	PL04072	PL04060 PL04072	PL04072	PL04072	PL04072	PL04072		PL04072		PL04072
	RE00011	RE00011	RE00011	RE00011	RE00011	RE00011	RE00011	RE00011	RE00011	RE00011	RE00011
										RL00021	
RL00005											
RL00013	RL00022	RL00022	RL00022	RL00022	RL00022	RL00022	RL00022	RL00022	RL00022	RL00023	RL00022
RL00014											
	9923600	9923600	9923600	9923600				9923650		9923650	9923600

MAXI SCOOTER

TOP
- performances -



DERBI	DERBI	DERBI	DERBI
GP1 LOW SEAT EU3	GP1 LOW SEAT EU3	RAMBLA	RAMBLA
07-08	07-08	08-09	08-09
125cc 4T LC	250cc 4T LC	125cc 4T LC	250cc 4T LC
Piaggio	Piaggio	Piaggio M287M	Piaggio

IT	EN	FR				
ALBERO A CAMME	CAM SHAFT	ARBRE À CAMES				
ALBERO MOTORE Sel 1/Sel 2	CRANKSHAFT Sel 1/Sel 2	VILEBREQUIN Sél 1/ Sél 2		IM070701 IM070702		IM070701 IM070702
CAMPANA FRIZIONE	CLUTCH HOUSING	CLOCHE EMBRAYAGE		FZ00395	FZ00395	FZ00395
CINGHIA DI TRASMISSIONE Bando	TRANSMISSION BELT Bando	COURROIE DE TRANSMISSION Bando		9927650		9928540
CINGHIA DI TRASMISSIONE Mitsuboshi	TRANSMISSION BELT Mitsuboshi	COURROIE DE TRANSMISSION Mitsuboshi			9935470	
CINGHIA DI TRASMISSIONE Altro	TRANSMISSION BELT Other	COURROIE DE TRANSMISSION Autres				
COLLETTORE ASPIRAZIONE	INLET MANIFOLD	COLLECTEUR ASPIRATION				
COLLETTORE ASPIRAZIONE SX	INLET MANIFOLD LEFT	COLLECTEUR ASPIRATION GAUCHE				
COLLETTORE ASPIRAZIONE DX	INLET MANIFOLD RIGHT	COLLECTEUR ASPIRATION DROITE				
FILTRO OLIO	OIL FILTER	FILTRE À HUILE		F007515	F007515	F007515
FRIZIONE	CLUTCH	EMBAYAGE		FZ00396		FZ00396
GRUPPO TERMICO Standard	CYLINDER KIT Ø standard	CYLINDRE COMPLET Standard				
GRUPPO TERMICO Maggiorato	CYLINDER KIT BIG BORE	CYLINDRE COMPLET Majoré				
KIT CUSCINETTI PARAOLI DI BANCO Serie	BEARINGS AND OIL SEALS KIT	KIT PALIERS JOINTS D'HUILE DE VILEBREQUIN Jeu				
KIT REVISIONE POMPA ACQUA	WATER PUMP REPAIR KIT	KIT RÉVISION POMPE À EAU		AA00826		AA00826
KIT TAGLIANDO	SERVICE KIT	KIT COUPON				
MASSE CENTRIFUGHE PESO ORIGINALE	ROLLER WEIGHTS Standard weight	MASSELOTES CENTRIFUGES POIDS D'ORIGINE				9931880
MEMBRANA CARBURATORE TIPO ORIGINALE	CARBURETOR DIAPHRAGM OEM	MEMBRANE CARBURATEUR TYPE ORIGINAL				
MEMBRANA CARBURATORE ADATTABILE	CARBURETOR DIAPHRAGM Adaptable	MEMBRANE CARBURATEUR ADAPTABLE		MC12106		MC12106
MOLLE CONTRASTO VARIATORE	REAR VARIATOR SPRING	RESSORTS CONTRASTE VARIATEUR				
MOLLA A GAS PER SELIA	SEAT GAS SPRING	RESSORT À GAZ POUR SELLE				
MOTORINO D'AVVIAMENTO	STARTER ENGINE	DÉMARREUR ÉLECTRIQUE		MA00012	MA00016	MA00012
PIATTELLO PORTATASSELI	VARIATOR SLIDERS	CURSEURS VARIATEUR				
POMPA BENZINA	FUEL PUMP	POMPE À ESSENCE				
PULEGGIA FISSA	FIXED SHEAVE	POULIE FIXE		PL04072		PL04072
REGOLATORE DI TENSIONE	RECTIFIER	RÉGULATEUR DE TENSION		RE00011	RE00004	RE00011
RUOTA LIBERA Completa	STARTER CLUTCH SET	ROUE LIBRE Complète				
RUOTA LIBERA RL + flangia	STARTER CLUTCH + FLANGE	ROUE LIBRE RL + flasque			RL00041	RL00041
RUOTA LIBERA RL nuda	STARTER CLUTCH	ROUE LIBRE RL nue				
RUOTA LIBERA Ingranaggio	STARTER CLUTCH GEAR	ROUE LIBRE Engrenage		RL00022	RL00023	RL00022
RUOTA LIBERA Flangia	STARTER CLUTCH FLANGE	ROUE LIBRE Flasque				
SERIE DISCHI FRIZIONE	CLUTCH PLATES KIT	JEU DISQUES EMBRAYAGE				
STATORE	STATOR	STATOR			ST00023	ST00023
TASSELLI TRAINO	VARIATOR SLIDERS	CURSEURS VARIATEUR				
VARIATORE VARIOTOP TPR	VARIOTOP TPR	VARIOTOP TPR				9923600

DERBI	DERBI	DERBI	DERBI	DERBI	DERBI	GILERA	GILERA	GILERA	GILERA	GILERA	GILERA
RAMBLA	RAMBLA EU3 2VER	RAMBLA EU3 2VER	SONAR 4T	SONAR 4T	VARIANT SPORT 4T EU3	DNA	DNA	FUOCO 4T-4V IE E3 LT	FUOCO IE EU3	GP	GP
10-11	08-08	08-08	09-11	09-09	12-12	01-01	01-01	13-14	07-13	07-08	09-11
300cc 4T LC	125cc 4T LC	250cc 4T LC	125cc 4T AC	150cc 4T AC	125cc 4T AC	125cc 4T LC	180cc 4T LC	500cc 4T LC	500cc 4T LC	800cc 4T-4V LC	800cc 4T-4V LC
Piaggio	Piaggio	Piaggio	Piaggio	Piaggio	Motore Piaggio	Piaggio	Piaggio	Piaggio	Piaggio	Piaggio	Piaggio
	IM070701 IM070702		IM070701 IM070702	IM070701 IM070702	IM070701						
FZ00395		FZ00395				FZ00377	FZ00377		FZ00384		
9927640	9928540	9927640	9927650	9927650	9927650	9927650					
							9935920	9935500	9935500	9935930	9935930
			CT00736	CT00736	CT00736	CT00734	CT00734				
F007515	F007515	F007515	F007515	F007515	F007515	F007515	F007515	F007524	F007524	F007524	F007524
			FZ00418	FZ00418	FZ00418	FZ00396					
AA00828	AA00826	AA00828				AA00817			AA00824		
TG00102			TG00100	TG00100				TG00112	TG00112		
9931880		9931880					9932790	9935990	9935990		
	MC12106		MC12107	MC12107	MC12107						
MA00016	MA00012	MA00016	MA00012	MA00012	MA00012	MA00012	MA00012	MA00030	MA00030		
	PL04072		PL04072	PL04072	PL04072	PL04060 PL04072	PL04061				
RE00004	RE00011	RE00004	RE00011	RE00011	RE00011	RE00011	RE00011		RE00004		
RL00021	RL00041	RL00041							RL00021		
RL00023	RL00022	RL00023	RL00022	RL00022	RL00022	RL00022	RL00022		RL00023		
ST00023	ST00023										
		9923650				9923600		9923250	9923250		

MAXI SCOOTER

TOP
- performances -



GILERA	GILERA	GILERA	GILERA
GP CENTENARIO	NEXUS	NEXUS EU3	NEXUS EU3
09-09	03-05	07-08	06-06
800cc 4T-4V LC	500cc 4T LC	125cc 4T LC	250cc 4T LC
Piaggio	Piaggio	Piaggio	Piaggio

IT	EN	FR				
ALBERO A CAMME	CAM SHAFT	ARBRE À CAMES				
ALBERO MOTORE Sel 1/Sel 2	CRANKSHAFT Sel 1/Sel 2	VILEBREQUIN Sél 1/ Sél 2				IM070701 IM070702
CAMPANA FRIZIONE	CLUTCH HOUSING	CLOCHE EMBRAYAGE			FZ00384	FZ00395 FZ00395
CINGHIA DI TRASMISSIONE Bando	TRANSMISSION BELT Bando	COURROIE DE TRANSMISSION Bando			9927630	9927650
CINGHIA DI TRASMISSIONE Mitsuboshi	TRANSMISSION BELT Mitsuboshi	COURROIE DE TRANSMISSION Mitsuboshi		9935930		9935470
CINGHIA DI TRASMISSIONE Altro	TRANSMISSION BELT Other	COURROIE DE TRANSMISSION Autres				
COLLETTORE ASPIRAZIONE	INLET MANIFOLD	COLLECTEUR ASPIRATION				
COLLETTORE ASPIRAZIONE SX	INLET MANIFOLD LEFT	COLLECTEUR ASPIRATION GAUCHE				
COLLETTORE ASPIRAZIONE DX	INLET MANIFOLD RIGHT	COLLECTEUR ASPIRATION DROITE				
FILTRO OLIO	OIL FILTER	FILTRE À HUILE		F007524	F007524	F007515 F007515
FRIZIONE	CLUTCH	EMBRAYAGE			FZ00383	FZ00396 FZ00382
GRUPPO TERMICO Standard	CYLINDER KIT Ø standard	CYLINDRE COMPLET Standard				
GRUPPO TERMICO Maggiorato	CYLINDER KIT BIG BORE	CYLINDRE COMPLET Majoré				
KIT CUSCINETTI PARAOLI DI BANCO Serie	BEARINGS AND OIL SEALS KIT	KIT PALIERS JOINTS D'HUILE DE VILEBREQUIN Jeu				
KIT REVISIONE POMPA ACQUA	WATER PUMP REPAIR KIT	KIT RÉVISION POMPE À EAU				AA00826 AA00828
KIT TAGLIANDO	SERVICE KIT	KIT COUPON				
MASSE CENTRIFUGHE PESO ORIGINALE	ROLLER WEIGHTS Standard weight	MASSELOTES CENTRIFUGES POIDS D'ORIGINE			9922330	9931880
MEMBRANA CARBURATORE TIPO ORIGINALE	CARBURETOR DIAPHRAGM OEM	MEMBRANE CARBURATEUR TYPE ORIGINAL				
MEMBRANA CARBURATORE ADATTABILE	CARBURETOR DIAPHRAGM Adaptable	MEMBRANE CARBURATEUR ADAPTABLE				MC12106
MOLLE CONTRASTO VARIATORE	REAR VARIATOR SPRING	RESSORTS CONTRASTE VARIATEUR			9926780	
MOLLA A GAS PER SELIA	SEAT GAS SPRING	RESSORT À GAZ POUR SELLE				
MOTORINO D'AVVIAMENTO	STARTER ENGINE	DÉMARREUR ÉLECTRIQUE			MA00030	MA00012 MA00016
PIATTELLO PORTATASSELI	VARIATOR SLIDERS	CURSEURS VARIATEUR				
POMPA BENZINA	FUEL PUMP	POMPE À ESSENCE				
PULEGGIA FISSA	FIXED SHEAVE	POULIE FIXE				PL04072
REGOLATORE DI TENSIONE	RECTIFIER	RÉGULATEUR DE TENSION			RE00004	RE00011 RE00004
RUOTA LIBERA Completa	STARTER CLUTCH SET	ROUE LIBRE Complète				
RUOTA LIBERA RL + flangia	STARTER CLUTCH + FLANGE	ROUE LIBRE RL + flasque			RL00021	RL00041
RUOTA LIBERA RL nuda	STARTER CLUTCH	ROUE LIBRE RL nue				
RUOTA LIBERA Ingranaggio	STARTER CLUTCH GEAR	ROUE LIBRE Engrenage			RL00023	RL00022 RL00023
RUOTA LIBERA Flangia	STARTER CLUTCH FLANGE	ROUE LIBRE Flasque				
SERIE DISCHI FRIZIONE	CLUTCH PLATES KIT	JEU DISQUES EMBRAYAGE				
STATORE	STATOR	STATOR			ST00005	ST00023
TASSELLI TRAINO	VARIATOR SLIDERS	CURSEURS VARIATEUR				
VARIATORE VARIOTOP TPR	VARIOTOP TPR	VARIOTOP TPR			9923250	9923600 9923650

GILERA	GILERA	GILERA	GILERA	GILERA	GILERA	GILERA	GILERA	GILERA	GILERA	GILERA	GILERA
NEXUS EU3	NEXUS EU3	NEXUS EU3	NEXUS EU3	NEXUS EU3	NEXUS IE EU3	NEXUS IE EU3	NEXUS SP EU3	NEXUS SP EU3	RUNNER	RUNNER 4T ST EU3	RUNNER FX
07-07	08-08	09-11	06-08	09-11	08-08	09-10	06-07	06-07	00-01	08-16	97-02
250cc 4T LC	300cc 4T LC	300cc 4T LC	500cc 4T LC	500cc 4T LC	125cc 4T LC	125cc 4T LC	250cc 4T LC	500cc 4T LC	180cc 4T LC	125cc 4T LC	125cc 2T LC
Piaggio	Piaggio	Piaggio	Piaggio	Piaggio	Piaggio	Piaggio	Piaggio	Piaggio	Piaggio	Piaggio	Piaggio
FZ00395	FZ00395	FZ00395	FZ00384	FZ00384	FZ00395	FZ00395		FZ00384	FZ00377		
				9927630	9927650	9927650				9927650	9915350
9935470	9935470	9935470	9935500					9935500			9935670
										CT00735	CT00728
F007515	F007515	F007515	F007524	F007524	F007515	F007515	F007515	F007524	F007515	F007515	
FZ00382					FZ00396	FZ00396			FZ00378		
AA00828	AA00828	AA00828	AA00824				AA00828		AA00817	AA00826	
	9931880	9931880	9935990	9935990			9931880	9935990			
										MC12106	
MA00016	MA00016	MA00016	MA00030	MA00030	MA00016	MA00016	MA00016	MA00030		MA00012	
										PL04072	
RE00004	RE00004	RE00004	RE00004	RE00004	RE00004	RE00004	RE00004	RE00004		RE00011	
RL00041	RL00021	RL00021	RL00021	RL00021	RL00041	RL00041	RL00041	RL00021			
RL00023	RL00023	RL00023	RL00023	RL00023	RL00023	RL00023	RL00023	RL00023		RL00022	
ST00023	ST00023	ST00023	ST00005	ST00005	ST00023	ST00023	ST00023	ST00005			
9923650	9923650	9923650	9923250		9923600	9923600		9923250	9923600		

MAXI SCOOTER

MAXI SCOOTER

TOP
- performances -



GILERA	GILERA	GILERA	GILERA
RUNNER FXR	RUNNER VX	RUNNER VX	RUNNER VX
97-02	00-01	02-04	05-06
180cc 2T LC	125cc 4T LC	125cc 4T LC	125cc 4T LC
Piaggio	Piaggio	Piaggio	Piaggio

IT	EN	FR				
ALBERO A CAMME	CAM SHAFT	ARBRE À CAMES				
ALBERO MOTORE Sel 1/Sel 2	CRANKSHAFT Sel 1/Sel 2	VILEBREQUIN Sél 1/ Sél 2			IM070701 IM070702	IM070701 IM070702
CAMPANA FRIZIONE	CLUTCH HOUSING	CLOCHE EMBRAYAGE			FZ00377	FZ00377 FZ00377
CINGHIA DI TRASMISSIONE Bando	TRANSMISSION BELT Bando	COURROIE DE TRANSMISSION Bando		9915340	9927650	9927650 9927650
CINGHIA DI TRASMISSIONE Mitsuboshi	TRANSMISSION BELT Mitsuboshi	COURROIE DE TRANSMISSION Mitsuboshi		9935780		
CINGHIA DI TRASMISSIONE Altro	TRANSMISSION BELT Other	COURROIE DE TRANSMISSION Autres				
COLLETTORE ASPIRAZIONE	INLET MANIFOLD	COLLECTEUR ASPIRATION		CT00728	CT00734	CT00734 CT00735
COLLETTORE ASPIRAZIONE SX	INLET MANIFOLD LEFT	COLLECTEUR ASPIRATION GAUCHE				
COLLETTORE ASPIRAZIONE DX	INLET MANIFOLD RIGHT	COLLECTEUR ASPIRATION DROITE				
FILTRO OLIO	OIL FILTER	FILTRE À HUILE			F007515	F007515 F007515
FRIZIONE	CLUTCH	EMBAYAGE			FZ00378	FZ00378 FZ00378
GRUPPO TERMICO Standard	CYLINDER KIT Ø standard	CYLINDRE COMPLET Standard				
GRUPPO TERMICO Maggiorato	CYLINDER KIT BIG BORE	CYLINDRE COMPLET Majoré				
KIT CUSCINETTI PARAOLI DI BANCO Serie	BEARINGS AND OIL SEALS KIT	KIT PALIERS JOINTS D'HUILE DE VILEBREQUIN Jeu				
KIT REVISIONE POMPA ACQUA	WATER PUMP REPAIR KIT	KIT RÉVISION POMPE À EAU			AA00817	AA00817 AA00817
KIT TAGLIANDO	SERVICE KIT	KIT COUPON				
MASSE CENTRIFUGHE PESO ORIGINALE	ROLLER WEIGHTS Standard weight	MASSELOTTE CENTRIFUGES POIDS D'ORIGINE		9922670		
MEMBRANA CARBURATORE TIPO ORIGINALE	CARBURETOR DIAPHRAGM OEM	MEMBRANE CARBURATEUR TYPE ORIGINAL				
MEMBRANA CARBURATORE ADATTABILE	CARBURETOR DIAPHRAGM Adaptable	MEMBRANE CARBURATEUR ADAPTABLE				MC12106
MOLLE CONTRASTO VARIATORE	REAR VARIATOR SPRING	RESSORTS CONTRASTE VARIATEUR				
MOLLA A GAS PER SELIA	SEAT GAS SPRING	RESSORT À GAZ POUR SELLE				
MOTORINO D'AVVIAMENTO	STARTER ENGINE	DÉMARREUR ÉLECTRIQUE			MA00012	MA00012 MA00012
PIATTELLO PORTATASSELI	VARIATOR SLIDERS	CURSEURS VARIATEUR				
POMPA BENZINA	FUEL PUMP	POMPE À ESSENCE				
PULEGGIA FISSA	FIXED SHEAVE	POULIE FIXE			PL04060 PL04072	PL04072 PL04072
REGOLATORE DI TENSIONE	RECTIFIER	RÉGULATEUR DE TENSION			RE00011	RE00011 RE00011
RUOTA LIBERA Completa	STARTER CLUTCH SET	ROUE LIBRE Complète				
RUOTA LIBERA RL + flangia	STARTER CLUTCH + FLANGE	ROUE LIBRE RL + flasque				
RUOTA LIBERA RL nuda	STARTER CLUTCH	ROUE LIBRE RL nue				
RUOTA LIBERA Ingranaggio	STARTER CLUTCH GEAR	ROUE LIBRE Engrenage			RL00022	RL00022 RL00022
RUOTA LIBERA Flangia	STARTER CLUTCH FLANGE	ROUE LIBRE Flasque				
SERIE DISCHI FRIZIONE	CLUTCH PLATES KIT	JEU DISQUES EMBRAYAGE				
STATORE	STATOR	STATOR				
TASSELLI TRAINO	VARIATOR SLIDERS	CURSEURS VARIATEUR				
VARIATORE VARIOTOP TPR	VARIOTOP TPR	VARIOTOP TPR			9923600	9923600 9923600

GILERA	GILERA	GILERA	GILERA	GILERA	GILERA	GILERA	GILERA	GILERA	GILERA	GILERA	HONDA
RUNNER VX 4T EU3	RUNNER VX RACE	RUNNER VX SC	RUNNER VXR	RUNNER VXR	RUNNER VXR	RUNNER VXR 4T ST EU3	RUNNER VXR EU3	RUNNER VXR RACE 200	TYPHOON	TYPHOON X-XR	@ [NES]
06-07	06-06	06-07	00-01	02-04	05-06	08-11	07-07	06-06	95-98	99-00	00-06
125cc 4T LC	125cc 4T LC	125cc 4T LC	180cc 4T LC	200cc 4T LC	200cc 4T LC	200cc 4T LC	200cc 4T LC	125cc 4T LC	125cc 2T AC	125cc 2T AC	125cc 4T LC
Piaggio	Piaggio	Piaggio	Piaggio	Piaggio	Piaggio	Piaggio	Piaggio	Piaggio	Piaggio	Piaggio	Honda
IM070701 IM070702	IM070701 IM070702	IM070701 IM070702									IM07055
			FZ00377	FZ00395	FZ00395						FZ00375
9927650	9927650	9927650							9915350	9915350	
			9935920	9935920	9935920	9935920	9935920	9935920	9935670	9935670	9935770
											9923140
	CT00735	CT00735	CT00734	CT00734	CT00735		CT00735	CT00735	CT00728	CT00728	
F007515	F007515	F007515	F007515	F007515	F007515	F007515	F007515	F007515			
			FZ00378								FZ00386
											9929650
											9929450
											KK01014
AA00826	AA00826	AA00826	AA00817	AA00826	AA00826	AA00826	AA00826	AA00826			AA00813
			9932790	9932790	9932790	9932790	9932790	9932790			9916670
											MC12004
MC12106	MC12106	MC12106				MC12106	MC12106	MC12106			MC12104
											9926770
MA00012	MA00012	MA00012	MA00012	MA00012	MA00012	MA00012	MA00012	MA00012			MA00006
PL04072	PL04072	PL04072	PL04061								
RE00011	RE00011	RE00011		RE00011	RE00011	RE00011	RE00011	RE00011			
											RL00028
											RL00005
RL00022	RL00022	RL00022	RL00022	RL00022	RL00022	RL00022	RL00022	RL00022			
											AA00854
			9923600	9923650	9923650						9923410

MAXI SCOOTER

MAXI SCOOTER

TOP
- performances -



HONDA	HONDA	HONDA	HONDA
@ [NES]	BALI	BALI	CN SPAZIO/ HELIX
00-06	96-01	96-01	86-99
150cc 4T LC	125cc 4T AC	150cc 4T AC	250cc 4T LC
Honda	Honda	Honda	Honda

IT	EN	FR				
ALBERO A CAMME	CAM SHAFT	ARBRE À CAMES				
ALBERO MOTORE Sel 1/Sel 2	CRANKSHAFT Sel 1/Sel 2	VILEBREQUIN Sél 1/ Sél 2		IM07056		
CAMPANA FRIZIONE	CLUTCH HOUSING	CLOCHE EMBRAYAGE		FZ00375		
CINGHIA DI TRASMISSIONE Bando	TRANSMISSION BELT Bando	COURROIE DE TRANSMISSION Bando				9915410
CINGHIA DI TRASMISSIONE Mitsuboshi	TRANSMISSION BELT Mitsuboshi	COURROIE DE TRANSMISSION Mitsuboshi		9935770	9935770	9935770
CINGHIA DI TRASMISSIONE Altro	TRANSMISSION BELT Other	COURROIE DE TRANSMISSION Autres		9923140	9923140	9923140
COLLETTORE ASPIRAZIONE	INLET MANIFOLD	COLLECTEUR ASPIRATION				
COLLETTORE ASPIRAZIONE SX	INLET MANIFOLD LEFT	COLLECTEUR ASPIRATION GAUCHE				
COLLETTORE ASPIRAZIONE DX	INLET MANIFOLD RIGHT	COLLECTEUR ASPIRATION DROITE				
FILTRO OLIO	OIL FILTER	FILTRE À HUILE				
FRIZIONE	CLUTCH	EMBAYAGE		FZ00386		
GRUPPO TERMICO Standard	CYLINDER KIT Ø standard	CYLINDRE COMPLET Standard		9929950		
GRUPPO TERMICO Maggiorato	CYLINDER KIT BIG BORE	CYLINDRE COMPLET Majoré				
KIT CUSCINETTI PARAOLI DI BANCO Serie	BEARINGS AND OIL SEALS KIT	KIT PALIERS JOINTS D'HUILE DE VILEBREQUIN Jeu		KK01014	KK01014	KK01014
KIT REVISIONE POMPA ACQUA	WATER PUMP REPAIR KIT	KIT RÉVISION POMPE À EAU		AA00813		
KIT TAGLIANDO	SERVICE KIT	KIT COUPON				
MASSE CENTRIFUGHE PESO ORIGINALE	ROLLER WEIGHTS Standard weight	MASSELOTTE CENTRIFUGES POIDS D'ORIGINE		9924320		
MEMBRANA CARBURATORE TIPO ORIGINALE	CARBURETOR DIAPHRAGM OEM	MEMBRANE CARBURATEUR TYPE ORIGINAL		MC12004		
MEMBRANA CARBURATORE ADATTABILE	CARBURETOR DIAPHRAGM Adaptable	MEMBRANE CARBURATEUR ADAPTABLE		MC12104		
MOLLE CONTRASTO VARIATORE	REAR VARIATOR SPRING	RESSORTS CONTRASTE VARIATEUR		9926770		
MOLLA A GAS PER SELIA	SEAT GAS SPRING	RESSORT À GAZ POUR SELLE				
MOTORINO D'AVVIAMENTO	STARTER ENGINE	DÉMARREUR ÉLECTRIQUE		MA00006		
PIATTELLO PORTATASSELI	VARIATOR SLIDERS	CURSEURS VARIATEUR				
POMPA BENZINA	FUEL PUMP	POMPE À ESSENCE				
PULEGGIA FISSA	FIXED SHEAVE	POULIE FIXE				
REGOLATORE DI TENSIONE	RECTIFIER	RÉGULATEUR DE TENSION				
RUOTA LIBERA Completa	STARTER CLUTCH SET	ROUE LIBRE Complète				
RUOTA LIBERA RL + flangia	STARTER CLUTCH + FLANGE	ROUE LIBRE RL + flasque		RL00028		RL00004
RUOTA LIBERA RL nuda	STARTER CLUTCH	ROUE LIBRE RL nue		RL00005		
RUOTA LIBERA Ingranaggio	STARTER CLUTCH GEAR	ROUE LIBRE Engrenage				
RUOTA LIBERA Flangia	STARTER CLUTCH FLANGE	ROUE LIBRE Flasque				
SERIE DISCHI FRIZIONE	CLUTCH PLATES KIT	JEU DISQUES EMBRAYAGE				
STATORE	STATOR	STATOR				
TASSELLI TRAINO	VARIATOR SLIDERS	CURSEURS VARIATEUR		AA00854		AA00853
VARIATORE VARIOTOP TPR	VARIOTOP TPR	VARIOTOP TPR		9923410	9923410	9923410

HONDA	HONDA	HONDA	HONDA	HONDA	HONDA	HONDA	HONDA	HONDA	HONDA	HONDA	HONDA
DYLAN [SES]	DYLAN [SES]	FORESIGHT [FES]	FORESIGHT [FES] D.D.	FORZA	FORZA	FORZA EURO 4	FORZA EX [NSS]	FORZA X [NSS]	FORZA [NSS A]	FORZA [NSS S]	FORZA [NSS]
02-04	02-04	98-99	00-05	13-17	13-17	18-20	05-07	05-07	08-11	08-11	02-07
125cc 4T LC	150cc 4T LC	250cc 4T LC	250cc 4T LC	125cc 4T-2V LC	300cc 4T 4V LC	300cc 4T 4V LC	250cc 4T-2V LC	250cc 4T-2V LC	250cc 4T-4V LC	250cc 4T-4V LC	250cc 4T-2V LC
Honda	Honda	Honda	Honda	Honda			Honda	Honda	Honda	Honda	Honda
IM07055	IM07056										
FZ00375	FZ00375	FZ00391			FZ00391	FZ00391					FZ00391
		9917990	9917990		9927480	9927480					9917990
9935770	9935770	9935720	9935720								9935720
9923140	9923140										
						F007513	F007513		F007513	F007513	
FZ00386	FZ00386	FZ00390 FZ00392	FZ00390 FZ00392		FZ00392	FZ00392					
9929650	9929950			9936650 9937450							
9929450											
KK01014	KK01014										
AA00813	AA00813	AA00814	AA00814		AA00822	AA00822					
9916670	9924320	9915990									
MC12004	MC12004										
MC12104	MC12104										
9926770	9926770		9926800		9929890			9926800			9926800
MA00006	MA00006				MA00032	MA00032					
					PL04078	PL04078					
					PL04076	PL04076					
RL00028	RL00028	RL00004	RL00004		RL00030	RL00030	RL00030	RL00030	RL00030	RL00030	RL00004
RL00005	RL00005										
					RL00029	RL00029		RL00029	RL00029		
					ST00024	ST00024					
AA00854	AA00854	AA00853	AA00853		AA00853	AA00853	AA00853	AA00853	AA00853	AA00853	AA00853
9923410	9923410				9926040	9926040					

MAXI SCOOTER

MAXI SCOOTER

TOP
- performances -



HONDA	HONDA	HONDA	HONDA
JAZZ ES REFLEX [NSS]	JAZZ REFLEX[NSS]	PANTHEON IE [FES]	PANTHEON IE [FES]
01-04	01-01	03-05	03-05
250cc 4T-2V LC	250cc 4T-2V LC	125cc 4T-2V LC	150cc 4T-2V LC
Honda	Honda	Honda	Honda

IT	EN	FR				
ALBERO A CAMME	CAM SHAFT	ARBRE À CAMES				
ALBERO MOTORE Sel 1/Sel 2	CRANKSHAFT Sel 1/Sel 2	VILEBREQUIN Sél 1/ Sél 2				IM07055 IM07056
CAMPANA FRIZIONE	CLUTCH HOUSING	CLOCHE EMBRAYAGE		FZ00391	FZ00391	FZ00375 FZ00375
CINGHIA DI TRASMISSIONE Bando	TRANSMISSION BELT Bando	COURROIE DE TRANSMISSION Bando		9917990	9917990	
CINGHIA DI TRASMISSIONE Mitsuboshi	TRANSMISSION BELT Mitsuboshi	COURROIE DE TRANSMISSION Mitsuboshi		9935720	9935720	9935770 9935770
CINGHIA DI TRASMISSIONE Altro	TRANSMISSION BELT Other	COURROIE DE TRANSMISSION Autres				9923140 9923140
COLLETTORE ASPIRAZIONE	INLET MANIFOLD	COLLECTEUR ASPIRATION				
COLLETTORE ASPIRAZIONE SX	INLET MANIFOLD LEFT	COLLECTEUR ASPIRATION GAUCHE				
COLLETTORE ASPIRAZIONE DX	INLET MANIFOLD RIGHT	COLLECTEUR ASPIRATION DROITE				
FILTRO OLIO	OIL FILTER	FILTRE À HUILE				
FRIZIONE	CLUTCH	EMBAYAGE				FZ00386
GRUPPO TERMICO Standard	CYLINDER KIT Ø standard	CYLINDRE COMPLET Standard				9929650 9929950
GRUPPO TERMICO Maggiorato	CYLINDER KIT BIG BORE	CYLINDRE COMPLET Majoré				9929450
KIT CUSCINETTI PARAOLI DI BANCO Serie	BEARINGS AND OIL SEALS KIT	KIT PALIERS JOINTS D'HUILE DE VILEBREQUIN Jeu				KK01014 KK01014
KIT REVISIONE POMPA ACQUA	WATER PUMP REPAIR KIT	KIT RÉVISION POMPE À EAU				AA00813 AA00813
KIT TAGLIANDO	SERVICE KIT	KIT COUPON				
MASSE CENTRIFUGHE PESO ORIGINALE	ROLLER WEIGHTS Standard weight	MASSELOTTE CENTRIFUGES POIDS D'ORIGINE				9916670
MEMBRANA CARBURATORE TIPO ORIGINALE	CARBURETOR DIAPHRAGM OEM	MEMBRANE CARBURATEUR TYPE ORIGINAL				
MEMBRANA CARBURATORE ADATTABILE	CARBURETOR DIAPHRAGM Adaptable	MEMBRANE CARBURATEUR ADAPTABLE				
MOLLE CONTRASTO VARIATORE	REAR VARIATOR SPRING	RESSORTS CONTRASTE VARIATEUR		9926800	9926800	9926770 9926770
MOLLA A GAS PER SELIA	SEAT GAS SPRING	RESSORT À GAZ POUR SELLE				
MOTORINO D'AVVIAMENTO	STARTER ENGINE	DÉMARREUR ÉLECTRIQUE				MA00006 MA00006
PIATTELLO PORTATASSELI	VARIATOR SLIDERS	CURSEURS VARIATEUR				
POMPA BENZINA	FUEL PUMP	POMPE À ESSENCE				
PULEGGIA FISSA	FIXED SHEAVE	POULIE FIXE				
REGOLATORE DI TENSIONE	RECTIFIER	RÉGULATEUR DE TENSION				
RUOTA LIBERA Completa	STARTER CLUTCH SET	ROUE LIBRE Complète				
RUOTA LIBERA RL + flangia	STARTER CLUTCH + FLANGE	ROUE LIBRE RL + flasque		RL00004	RL00004	RL00028 RL00028
RUOTA LIBERA RL nuda	STARTER CLUTCH	ROUE LIBRE RL nue				RL00005 RL00005
RUOTA LIBERA Ingranaggio	STARTER CLUTCH GEAR	ROUE LIBRE Engrenage				
RUOTA LIBERA Flangia	STARTER CLUTCH FLANGE	ROUE LIBRE Flasque				
SERIE DISCHI FRIZIONE	CLUTCH PLATES KIT	JEU DISQUES EMBRAYAGE				
STATORE	STATOR	STATOR				
TASSELLI TRAINO	VARIATOR SLIDERS	CURSEURS VARIATEUR		AA00853	AA00853	AA00854 AA00854
VARIATORE VARIOTOP TPR	VARIOTOP TPR	VARIOTOP TPR				9923410 9923410

HONDA	HONDA	HONDA	HONDA	HONDA	HONDA	HONDA	HONDA	HONDA	HONDA	HONDA	HONDA
PANTHEON [FES]	PANTHEON [FES]	PCX	PCX	PCX	PCX	PCX	PCX	PSI [PES]	PSI [PES]	SH	SH
98-02	98-02	10-11	12-12	13-13	14-14	15-18	13-17	06-10	06-10	01-04	01-04
125cc 2T LC	150cc 2T LC	125cc 4T-2V LC	125cc 4T-2V LC	125cc 4T-2V LC	125cc 4T-2V LC	125cc 4T-2V LC	150cc 4T-2V LC	125cc 4T LC	150cc 4T LC	125cc 4T-2V LC	150cc 4T-2V LC
Honda	Honda	Honda	Honda	Honda	Honda	Honda	Honda	Honda	Honda	Honda	Honda
								IM07055	IM07056	IM07055	IM07056
FZ00391	FZ00391	FZ00406		FZ00406			FZ00406	FZ00375	FZ00375	FZ00375	FZ00375
9918000	9918000		9935970	9935970	9935970	9935980					
								9935770	9935770	9935770	9935770
								9923140	9923140	9923140	9923140
		FZ00407		FZ00407			FZ00407	FZ00386	FZ00386	FZ00386	FZ00386
				9936650 9937450	9936650	9936650	9936950	9929650	9929950	9929650	9929950
								9929450		9929450	
								KK01014	KK01014	KK01014	KK01014
AA00812	AA00812	AA00834	AA00834	AA00834			AA00834	AA00813	AA00813	AA00813	AA00813
		TG00113	TG00114	TG00114	TG00114	TG00115				TG00105	TG00105
								9916670	9924320	9916670	9924320
										MC12004	MC12004
										MC12104	MC12104
								9926770	9926770	9926770	9926770
								MA00006	MA00006	MA00006	MA00006
										PL04073	PL04073
								RL00028	RL00028	RL00028	RL00028
								RL00005	RL00005	RL00005	RL00005
								AA00854	AA00854	AA00854	AA00854
								9923410	9923410	9923410	9923410

MAXI SCOOTER

MAXI SCOOTER

TOP
- performances -



HONDA	HONDA	HONDA	HONDA
SH I ABS	SH I ABS	SH IE SCOOPY	SH IE SCOOPY
13-19	13-19	05-12	05-12
125cc 4T-2V LC	150cc 4T-2V LC	125cc 4T-2V LC	150cc 4T LC
Honda	Honda	Honda	Honda

IT	EN	FR					
ALBERO A CAMME	CAM SHAFT	ARBRE À CAMES					
ALBERO MOTORE Sel 1/Sel 2	CRANKSHAFT Sel 1/Sel 2	VILEBREQUIN Sel 1/ Sel 2		IM07075	IM07076	IM07055	IM07056
CAMPANA FRIZIONE	CLUTCH HOUSING	CLOCHE EMBRAYAGE		FZ00406	FZ00406	FZ00375	FZ00375
CINGHIA DI TRASMISSIONE Bando	TRANSMISSION BELT Bando	COURROIE DE TRANSMISSION Bando					
CINGHIA DI TRASMISSIONE Mitsuboshi	TRANSMISSION BELT Mitsuboshi	COURROIE DE TRANSMISSION Mitsuboshi		9935870	9935870	9935770	9935770
CINGHIA DI TRASMISSIONE Altro	TRANSMISSION BELT Other	COURROIE DE TRANSMISSION Autres				9923140	9923140
COLLETTORE ASPIRAZIONE	INLET MANIFOLD	COLLECTEUR ASPIRATION					
COLLETTORE ASPIRAZIONE SX	INLET MANIFOLD LEFT	COLLECTEUR ASPIRATION GAUCHE					
COLLETTORE ASPIRAZIONE DX	INLET MANIFOLD RIGHT	COLLECTEUR ASPIRATION DROITE					
FILTRO OLIO	OIL FILTER	FILTRE À HUILE					
FRIZIONE	CLUTCH	EMBRAYAGE		FZ00405	FZ00405	FZ00386	FZ00386
GRUPPO TERMICO Standard	CYLINDER KIT Ø standard	CYLINDRE COMPLET Standard		9936650 9937450	9936950	9929650	9929950
GRUPPO TERMICO Maggiorato	CYLINDER KIT BIG BORE	CYLINDRE COMPLET Majoré				9929450	
KIT CUSCINETTI PARAOLI DI BANCO Serie	BEARINGS AND OIL SEALS KIT	KIT PALIERS JOINTS D'HUILE DE VILEBREQUIN Jeu				KK01014	KK01014
KIT REVISIONE POMPA ACQUA	WATER PUMP REPAIR KIT	KIT RÉVISION POMPE À EAU		AA00834	AA00834	AA00813	AA00813
KIT TAGLIANDO	SERVICE KIT	KIT COUPON				TG00105	TG00105
MASSE CENTRIFUGHE PESO ORIGINALE	ROLLER WEIGHTS Standard weight	MASSELOTTE CENTRIFUGES POIDS D'ORIGINE		9916710		9916670	9924320
MEMBRANA CARBURATORE TIPO ORIGINALE	CARBURETOR DIAPHRAGM OEM	MEMBRANE CARBURATEUR TYPE ORIGINAL					
MEMBRANA CARBURATORE ADATTABILE	CARBURETOR DIAPHRAGM Adaptable	MEMBRANE CARBURATEUR ADAPTABLE					
MOLLE CONTRASTO VARIATORE	REAR VARIATOR SPRING	RESSORTS CONTRASTE VARIATEUR				9926770	9926770
MOLLA A GAS PER SELIA	SEAT GAS SPRING	RESSORT À GAZ POUR SELLE					
MOTORINO D'AVVIAMENTO	STARTER ENGINE	DÉMARREUR ÉLECTRIQUE				MA00006	MA00006
PIATTELLO PORTATASSELI	VARIATOR SLIDERS	CURSEURS VARIATEUR					
POMPA BENZINA	FUEL PUMP	POMPE À ESSENCE		PB00907	PB00907		
PULEGGIA FISSA	FIXED SHEAVE	POULIE FIXE		PL04077	PL04077	PL04073	PL04073
REGOLATORE DI TENSIONE	RECTIFIER	RÉGULATEUR DE TENSION				RE00021	RE00021
RUOTA LIBERA Completa	STARTER CLUTCH SET	ROUE LIBRE Complète					
RUOTA LIBERA RL + flangia	STARTER CLUTCH + FLANGE	ROUE LIBRE RL + flasque				RL00028	RL00028
RUOTA LIBERA RL nuda	STARTER CLUTCH	ROUE LIBRE RL nue				RL00005	RL00005
RUOTA LIBERA Ingranaggio	STARTER CLUTCH GEAR	ROUE LIBRE Engrenage					
RUOTA LIBERA Flangia	STARTER CLUTCH FLANGE	ROUE LIBRE Flasque					
SERIE DISCHI FRIZIONE	CLUTCH PLATES KIT	JEU DISQUES EMBRAYAGE					
STATORE	STATOR	STATOR				ST00026	ST00026
TASSELLI TRAINO	VARIATOR SLIDERS	CURSEURS VARIATEUR		AA00855	AA00855	AA00854	AA00854
VARIATORE VARIOTOP TPR	VARIOTOP TPR	VARIOTOP TPR				9923410	9923410

HONDA	HONDA	HONDA	HONDA	HONDA	HONDA	HONDA	HONDA	ITALJET	ITALJET	ITALJET	ITALJET
SH IE SCOOPY	SH IE SCOOPY	SILVER WING [FES]	SILVER WING [FES]	SILVER WING [FJS]	SILVER WING [FJS]	SW-T [FJS]	SW-T [FJS]	DRAGSTER	JET SET	JET SET	JUPITER
07-10	11-19	07-12	07-12	06-08	01-10	09-13	11-13	99-01	01-01	01-01	01-02
300cc 4T-4V LC	300cc 4T-4V LC	125cc 4T-2V LC	150cc 4T-2V LC	400cc 4T LC	600cc 4T LC	400cc 4T LC	600cc 4T LC	180cc 2T LC	125cc 4T AC	150cc 4T AC	125cc 4T LC
(NF02E)		Honda	(KF06E)	Honda	Honda	Honda	Honda		Leader	Leader	Minarelli YP
		IM07055	IM07056								IM07045
FZ00391	FZ00391	FZ00375	FZ00375								
9927480	9927480			9927490		9927490					9915380
		9935770	9935770		9935250		9935250				9935700
		9923140	9923140								
											CT00730
F007513	F007513			F007513	F007513	F007513	F007513		F007515	F007515	
FZ00392	FZ00392	FZ00386	FZ00386								FZ00371
		9929650	9929950								
		9929450									9929380
		KK01014	KK01014								KK01010
AA00822	AA00822	AA00813	AA00813	AA00836	AA00836	AA00836	AA00836				AA00805
TG00106	TG00106										
9931890	9931890	9924320	9924320	9931840	9931860	9931840	9931860	9922670			9915270
											MC12100
9929890	9929890	9926770	9926770								9929170
				9980220	9980220	9980220	9980220				
MA00032	MA00032	MA00006	MA00006								MA00017
PL04078	PL04078										
PL04076	PL04076										
RE00031	RE00029										
RL00030	RL00030	RL00028	RL00028								RL00002
		RL00005	RL00005								
RL00029	RL00029										
ST00024											
AA00853	AA00853	AA00854	AA00854	AA00853	AA00853	AA00853	AA00853				
9926040	9926040	9923410	9923410						9923600	9923600	9923550

MAXI SCOOTER

MAXI SCOOTER

TOP
- performances -



ITALJET	ITALJET	ITALJET	ITALJET
JUPITER	JUPITER	JUPITER	MILLENIUM
01-02	00-00	01-02	00-02
150cc 4T LC	250cc 4T LC	250cc 4T LC	125cc 4T LC
Minarelli YP	Minarelli YP	Minarelli YP	Minarelli YP

IT	EN	FR				
ALBERO A CAMME	CAM SHAFT	ARBRE À CAMES				
ALBERO MOTORE Sel 1/Sel 2	CRANKSHAFT Sel 1/Sel 2	VILEBREQUIN Sél 1/ Sél 2		IM07054	IM07054	IM07045
CAMPANA FRIZIONE	CLUTCH HOUSING	CLOCHE EMBRAYAGE		FZ00397		
CINGHIA DI TRASMISSIONE Bando	TRANSMISSION BELT Bando	COURROIE DE TRANSMISSION Bando		9915380	9915800	9915800
CINGHIA DI TRASMISSIONE Mitsuboshi	TRANSMISSION BELT Mitsuboshi	COURROIE DE TRANSMISSION Mitsuboshi		9935700	9935710	9935710
CINGHIA DI TRASMISSIONE Altro	TRANSMISSION BELT Other	COURROIE DE TRANSMISSION Autres				
COLLETTORE ASPIRAZIONE	INLET MANIFOLD	COLLECTEUR ASPIRATION		CT00730		CT00730
COLLETTORE ASPIRAZIONE SX	INLET MANIFOLD LEFT	COLLECTEUR ASPIRATION GAUCHE				
COLLETTORE ASPIRAZIONE DX	INLET MANIFOLD RIGHT	COLLECTEUR ASPIRATION DROITE				
FILTRO OLIO	OIL FILTER	FILTRE À HUILE				
FRIZIONE	CLUTCH	EMBAYAGE		FZ00401	FZ00388	FZ00401
GRUPPO TERMICO Standard	CYLINDER KIT Ø standard	CYLINDRE COMPLET Standard			9926850	9926850
GRUPPO TERMICO Maggiorato	CYLINDER KIT BIG BORE	CYLINDRE COMPLET Majoré		9929380		9929380
KIT CUSCINETTI PARAOLI DI BANCO Serie	BEARINGS AND OIL SEALS KIT	KIT PALIERS JOINTS D'HUILE DE VILEBREQUIN Jeu		KK01010	KK01007	KK01007
KIT REVISIONE POMPA ACQUA	WATER PUMP REPAIR KIT	KIT RÉVISION POMPE À EAU		AA00805	AA00806	AA00806
KIT TAGLIANDO	SERVICE KIT	KIT COUPON				
MASSE CENTRIFUGHE PESO ORIGINALE	ROLLER WEIGHTS Standard weight	MASSELOTES CENTRIFUGES POIDS D'ORIGINE			9918020	9915270
MEMBRANA CARBURATORE TIPO ORIGINALE	CARBURETOR DIAPHRAGM OEM	MEMBRANE CARBURATEUR TYPE ORIGINAL			MC12001	MC12001
MEMBRANA CARBURATORE ADATTABILE	CARBURETOR DIAPHRAGM Adaptable	MEMBRANE CARBURATEUR ADAPTABLE		MC12100	MC12101	MC12101
MOLLE CONTRASTO VARIATORE	REAR VARIATOR SPRING	RESSORTS CONTRASTE VARIATEUR		9929170	9929870	9929870
MOLLA A GAS PER SELIA	SEAT GAS SPRING	RESSORT À GAZ POUR SELLE				
MOTORINO D'AVVIAMENTO	STARTER ENGINE	DÉMARREUR ÉLECTRIQUE		MA00017	MA00010	MA00010
PIATTELLO PORTATASSELI	VARIATOR SLIDERS	CURSEURS VARIATEUR			PL04066	PL04066
POMPA BENZINA	FUEL PUMP	POMPE À ESSENCE				
PULEGGIA FISSA	FIXED SHEAVE	POULIE FIXE			PL04075	PL04075
REGOLATORE DI TENSIONE	RECTIFIER	RÉGULATEUR DE TENSION				
RUOTA LIBERA Completa	STARTER CLUTCH SET	ROUE LIBRE Complète				
RUOTA LIBERA RL + flangia	STARTER CLUTCH + FLANGE	ROUE LIBRE RL + flasque		RL00002	RL00010	RL00010
RUOTA LIBERA RL nuda	STARTER CLUTCH	ROUE LIBRE RL nue				
RUOTA LIBERA Ingranaggio	STARTER CLUTCH GEAR	ROUE LIBRE Engrenage			RL00011	RL00011
RUOTA LIBERA Flangia	STARTER CLUTCH FLANGE	ROUE LIBRE Flasque				
SERIE DISCHI FRIZIONE	CLUTCH PLATES KIT	JEU DISQUES EMBRAYAGE				
STATORE	STATOR	STATOR				
TASSELLI TRAINO	VARIATOR SLIDERS	CURSEURS VARIATEUR				
VARIATORE VARIOTOP TPR	VARIOTOP TPR	VARIOTOP TPR		9923550	9931790	9931790

ITALJET	ITALJET	ITALJET	KEEWAY	KEEWAY	KEEWAY	KEEWAY	KEEWAY	KEEWAY	KEEWAY	KEEWAY	KEEWAY
MILLENIUM	TORPEDO	TORPEDO	ARN	ARN	ARN	ARN	F-ACT	F-ACT	FOCUS	FOCUS	MATRIX
00-02	99-02	99-02	06-06	07-08	06-06	07-08	07-08	07-08	06-06	06-06	06-06
150cc 4T LC	125cc 4T AC	150cc 4T AC	125cc 4T AC	125cc 4T AC	150cc 4T AC	150cc 4T AC	125cc 4T AC	150cc 4T AC	125cc 4T AC	150cc 4T AC	125cc 4T AC
Minarelli YP	Leader	Leader									
9915380											
9935700			9935260	9935260	9935260	9935260	9935260	9935260	9935260	9935260	9935260
CT00730											
	F007515	F007515									
FZ00401											
9929380											
KK01010											
AA00805											
MC12100											
9929170											
MA00017											
RL00002											
9923550	9923600	9923600									

MAXI SCOOTER

MAXI SCOOTER

TOP
- performances -



KEEWAY	KEEWAY	KEEWAY	KEEWAY
MATRIX	MATRIX	MATRIX	OUTLOOK
07-08	06-06	07-08	07-08
125cc 4T AC	150cc 4T AC	150cc 4T AC	125cc 4T LC
			(QJ153MJ-2)

IT	EN	FR				
ALBERO A CAMME	CAM SHAFT	ARBRE À CAMES				
ALBERO MOTORE Sel 1/Sel 2	CRANKSHAFT Sel 1/Sel 2	VILEBREQUIN Sél 1/ Sél 2				
CAMPANA FRIZIONE	CLUTCH HOUSING	CLOCHE EMBRAYAGE				FZ00375
CINGHIA DI TRASMISSIONE Bando	TRANSMISSION BELT Bando	COURROIE DE TRANSMISSION Bando		9935260	9935260	9935260
CINGHIA DI TRASMISSIONE Mitsuboshi	TRANSMISSION BELT Mitsuboshi	COURROIE DE TRANSMISSION Mitsuboshi				9935770
CINGHIA DI TRASMISSIONE Altro	TRANSMISSION BELT Other	COURROIE DE TRANSMISSION Autres				9923140
COLLETTORE ASPIRAZIONE	INLET MANIFOLD	COLLECTEUR ASPIRATION				
COLLETTORE ASPIRAZIONE SX	INLET MANIFOLD LEFT	COLLECTEUR ASPIRATION GAUCHE				
COLLETTORE ASPIRAZIONE DX	INLET MANIFOLD RIGHT	COLLECTEUR ASPIRATION DROITE				
FILTRO OLIO	OIL FILTER	FILTRE À HUILE				
FRIZIONE	CLUTCH	EMBRAYAGE				FZ00386
GRUPPO TERMICO Standard	CYLINDER KIT Ø standard	CYLINDRE COMPLET Standard				9929650
GRUPPO TERMICO Maggiorato	CYLINDER KIT BIG BORE	CYLINDRE COMPLET Majoré				9929450
KIT CUSCINETTI PARAOLI DI BANCO Serie	BEARINGS AND OIL SEALS KIT	KIT PALIERS JOINTS D'HUILE DE VILEBREQUIN Jeu				
KIT REVISIONE POMPA ACQUA	WATER PUMP REPAIR KIT	KIT RÉVISION POMPE À EAU				
KIT TAGLIANDO	SERVICE KIT	KIT COUPON				
MASSE CENTRIFUGHE PESO ORIGINALE	ROLLER WEIGHTS Standard weight	MASSELOTTE CENTRIFUGES POIDS D'ORIGINE				
MEMBRANA CARBURATORE TIPO ORIGINALE	CARBURETOR DIAPHRAGM OEM	MEMBRANE CARBURATEUR TYPE ORIGINAL				
MEMBRANA CARBURATORE ADATTABILE	CARBURETOR DIAPHRAGM Adaptable	MEMBRANE CARBURATEUR ADAPTABLE				
MOLLE CONTRASTO VARIATORE	REAR VARIATOR SPRING	RESSORTS CONTRASTE VARIATEUR				9926770
MOLLA A GAS PER SELIA	SEAT GAS SPRING	RESSORT À GAZ POUR SELLE				
MOTORINO D'AVVIAMENTO	STARTER ENGINE	DÉMARREUR ÉLECTRIQUE				
PIATTELLO PORTATASSELI	VARIATOR SLIDERS	CURSEURS VARIATEUR				
POMPA BENZINA	FUEL PUMP	POMPE À ESSENCE				
PULEGGIA FISSA	FIXED SHEAVE	POULIE FIXE				
REGOLATORE DI TENSIONE	RECTIFIER	RÉGULATEUR DE TENSION				
RUOTA LIBERA Completa	STARTER CLUTCH SET	ROUE LIBRE Complète				
RUOTA LIBERA RL + flangia	STARTER CLUTCH + FLANGE	ROUE LIBRE RL + flasque				
RUOTA LIBERA RL nuda	STARTER CLUTCH	ROUE LIBRE RL nue				
RUOTA LIBERA Ingranaggio	STARTER CLUTCH GEAR	ROUE LIBRE Engrenage				
RUOTA LIBERA Flangia	STARTER CLUTCH FLANGE	ROUE LIBRE Flasque				
SERIE DISCHI FRIZIONE	CLUTCH PLATES KIT	JEU DISQUES EMBRAYAGE				
STATORE	STATOR	STATOR				
TASSELLI TRAINO	VARIATOR SLIDERS	CURSEURS VARIATEUR				
VARIATORE VARIOTOP TPR	VARIOTOP TPR	VARIOTOP TPR				9923410

KEEWAY	KEEWAY	KEEWAY	KEEWAY	KYMCO	KYMCO	KYMCO	KYMCO	KYMCO	KYMCO	KYMCO	KYMCO
OUTLOOK	OUTLOOK DR	OUTLOOK DR	SILVERBLADE 4T	AGILITY	AGILITY	AGILITY CARRY	AGILITY CARRY EURO4	AGILITY EU3	AGILITY I PLUS	AGILITY PLUS	AGILITY PLUS
07-08	07-11	07-11	11-11	06-06	06-08	11-11	17-17	06-08	14-14	14-14	14-14
150cc 4T LC	125cc 4T LC	150cc 4T LC	125cc 4T LC	125cc 4T AC	150cc 4T AC	125cc 4T AC	125cc 4T AC	125cc 4T AC	200cc 4T AC	125cc 4T AC	125cc 4T AC
(QJ158MJ)											
				IM07071		IM07071		IM07071		IM07071	
FZ00375				FZ00375				FZ00375	FZ00375	FZ00375	
				9926430				9926430			
9935770	9935770	9935770	9935770	9935740		9935740		9935740			9935740
9923140	9923140	9923140	9923140								
FZ00386				FZ00386				FZ00386	FZ00386	FZ00386	
9929950				9936400		9936400	9936400	9936400			9936400
				9936400		9936400	9936400	9936400			9936400
											TG00103
				MC12103							
9926770											
				MA00007	MA00007			MA00007			
				PL04074		PL04074		PL04074	PL04074		PL04074
				RE00013				RE00013		RE00019	
				RL00025				RL00025			
				RL00024				RL00024			
9923410				9927830	9927830						

MAXI SCOOTER

MAXI SCOOTER



KYMC0	KYMC0	KYMC0	KYMC0
AGILITY PLUS E4	AGILITY R16	AGILITY R16	AGILITY R16
16-16	08-08	09-09	12-12
125cc 4T AC	125cc 4T AC	125cc 4T AC	125cc 4T AC

IT	EN	FR				
ALBERO A CAMME	CAM SHAFT	ARBRE À CAMES				
ALBERO MOTORE Sel 1/Sel 2	CRANKSHAFT Sel 1/Sel 2	VILEBREQUIN Sél 1/ Sél 2		IM07071	IM07071	IM07071
CAMPANA FRIZIONE	CLUTCH HOUSING	CLOCHE EMBRAYAGE			FZ00375	FZ00375 FZ00375
CINGHIA DI TRASMISSIONE Bando	TRANSMISSION BELT Bando	COURROIE DE TRANSMISSION Bando			9926430	9926430
CINGHIA DI TRASMISSIONE Mitsuboshi	TRANSMISSION BELT Mitsuboshi	COURROIE DE TRANSMISSION Mitsuboshi		9935740	9935740	9935740
CINGHIA DI TRASMISSIONE Altro	TRANSMISSION BELT Other	COURROIE DE TRANSMISSION Autres				
COLLETTORE ASPIRAZIONE	INLET MANIFOLD	COLLECTEUR ASPIRATION			CT00742	CT00742
COLLETTORE ASPIRAZIONE SX	INLET MANIFOLD LEFT	COLLECTEUR ASPIRATION GAUCHE				
COLLETTORE ASPIRAZIONE DX	INLET MANIFOLD RIGHT	COLLECTEUR ASPIRATION DROITE				
FILTRO OLIO	OIL FILTER	FILTRE À HUILE				
FRIZIONE	CLUTCH	EMBRAYAGE			FZ00386	FZ00386 FZ00386
GRUPPO TERMICO Standard	CYLINDER KIT Ø standard	CYLINDRE COMPLET Standard		9936400	9936400	9936400 9936400
GRUPPO TERMICO Maggiorato	CYLINDER KIT BIG BORE	CYLINDRE COMPLET Majoré		9936400	9936400	9936400 9936400
KIT CUSCINETTI PARAOLI DI BANCO Serie	BEARINGS AND OIL SEALS KIT	KIT PALIERS JOINTS D'HUILE DE VILEBREQUIN Jeu				
KIT REVISIONE POMPA ACQUA	WATER PUMP REPAIR KIT	KIT RÉVISION POMPE À EAU				
KIT TAGLIANDO	SERVICE KIT	KIT COUPON		TG00103	TG00103	TG00103
MASSE CENTRIFUGHE PESO ORIGINALE	ROLLER WEIGHTS Standard weight	MASSELOTTE CENTRIFUGES POIDS D'ORIGINE			9917640	9917640
MEMBRANA CARBURATORE TIPO ORIGINALE	CARBURETOR DIAPHRAGM OEM	MEMBRANE CARBURATEUR TYPE ORIGINAL			MC12103	MC12103
MEMBRANA CARBURATORE ADATTABILE	CARBURETOR DIAPHRAGM Adaptable	MEMBRANE CARBURATEUR ADAPTABLE				
MOLLE CONTRASTO VARIATORE	REAR VARIATOR SPRING	RESSORTS CONTRASTE VARIATEUR				
MOLLA A GAS PER SELIA	SEAT GAS SPRING	RESSORT À GAZ POUR SELLE				
MOTORINO D'AVVIAMENTO	STARTER ENGINE	DÉMARREUR ÉLECTRIQUE			MA00007	MA00007
PIATTELLO PORTATASSELI	VARIATOR SLIDERS	CURSEURS VARIATEUR				
POMPA BENZINA	FUEL PUMP	POMPE À ESSENCE				
PULEGGIA FISSA	FIXED SHEAVE	POULIE FIXE		PL04074	PL04074	PL04074
REGOLATORE DI TENSIONE	RECTIFIER	RÉGULATEUR DE TENSION			RE00019	RE00019 RE00019
RUOTA LIBERA Completa	STARTER CLUTCH SET	ROUE LIBRE Complète				
RUOTA LIBERA RL + flangia	STARTER CLUTCH + FLANGE	ROUE LIBRE RL + flasque				
RUOTA LIBERA RL nuda	STARTER CLUTCH	ROUE LIBRE RL nue				
RUOTA LIBERA Ingranaggio	STARTER CLUTCH GEAR	ROUE LIBRE Engrenage				
RUOTA LIBERA Flangia	STARTER CLUTCH FLANGE	ROUE LIBRE Flasque				
SERIE DISCHI FRIZIONE	CLUTCH PLATES KIT	JEU DISQUES EMBRAYAGE				
STATORE	STATOR	STATOR			ST00025	ST00025 ST00025
TASSELLI TRAINO	VARIATOR SLIDERS	CURSEURS VARIATEUR				
VARIATORE VARIOTOP TPR	VARIOTOP TPR	VARIOTOP TPR			9927830	9927830

KYMC0	KYMC0	KYMC0	KYMC0	KYMC0	KYMC0	KYMC0	KYMC0	KYMC0	KYMC0	KYMC0	KYMC0
AGILITY R16	AGILITY R16	AGILITY R16	AGILITY R16	AGILITY RS	AGILITYI R16	B&W	B&W	B&W	B&W EU2	B&W EU2	B&W EU2
12-12	08-08	09-09	12-12	09-09	10-10	00-00	00-00	00-00	03-04	03-04	03-03
125cc 4T AC	150cc 4T AC	150cc 4T AC	200cc 4T AC	125cc 4T AC	200cc 4T AC	125cc 4T LC	150cc 4T LC	250cc 4T LC	125cc 4T LC	150cc 4T LC	250cc 4T LC
	IM07071	IM07071		IM07071				IM07057			IM07057
	FZ00375	FZ00375	FZ00375	FZ00375	FZ00375			FZ00399			FZ00399
	9926430	9926430	9926430	9926430	9926430	9915220	9915220		9915220	9915220	
9935740	9935740	9935740		9935740		9935660	9935660		9935660	9935660	
								9922420			9922420
	CT00742	CT00742									
	FZ00386	FZ00386	FZ00386	FZ00386	FZ00386			FZ00400			FZ00400
				9936400							
				9936400							
						AA00815	AA00815	AA00816	AA00815	AA00815	AA00816
TG00103	TG00103	TG00103									
	9917640	9917640	9917640			9916710	9916710	9916080			9916080
	MC12103	MC12103									
	MA00007	MA00007	MA00007	MA00007	MA00007	MA00007	MA00007	MA00031	MA00007	MA00007	MA00031
PL04074	PL04074	PL04074	PL04074	PL04074	PL04074						
	RE00019	RE00019		RE00019		RE00026	RE00026	RE00026	RE00026	RE00026	RE00026
						RL00006	RL00006	RL00008	RL00006	RL00006	RL00008
						RL00007	RL00007	RL00009			RL00009
ST00025	ST00025	ST00025		ST00025							
	9927830	9927830	9927830	9927830	9927830			9923670			

KYMCO	KYMCO	KYMCO	KYMCO
DINK	DINK	DINK CLASSIC	DINK CLASSIC
97-98	97-98	02-02	02-02
125cc 4T LC	150cc 4T LC	125cc 4T LC	150cc 4T LC

IT	EN	FR				
ALBERO A CAMME	CAM SHAFT	ARBRE À CAMES				
ALBERO MOTORE Sel 1/Sel 2	CRANKSHAFT Sel 1/Sel 2	VILEBREQUIN Sél 1/ Sél 2				
CAMPANA FRIZIONE	CLUTCH HOUSING	CLOCHE EMBRAYAGE				
CINGHIA DI TRASMISSIONE Bando	TRANSMISSION BELT Bando	COURROIE DE TRANSMISSION Bando		9915220	9915220	9915220
CINGHIA DI TRASMISSIONE Mitsuboshi	TRANSMISSION BELT Mitsuboshi	COURROIE DE TRANSMISSION Mitsuboshi		9935660	9935660	9935660
CINGHIA DI TRASMISSIONE Altro	TRANSMISSION BELT Other	COURROIE DE TRANSMISSION Autres				
COLLETTORE ASPIRAZIONE	INLET MANIFOLD	COLLECTEUR ASPIRATION				
COLLETTORE ASPIRAZIONE SX	INLET MANIFOLD LEFT	COLLECTEUR ASPIRATION GAUCHE				
COLLETTORE ASPIRAZIONE DX	INLET MANIFOLD RIGHT	COLLECTEUR ASPIRATION DROITE				
FILTRO OLIO	OIL FILTER	FILTRE À HUILE				
FRIZIONE	CLUTCH	EMBRAYAGE				
GRUPPO TERMICO Standard	CYLINDER KIT Ø standard	CYLINDRE COMPLET Standard				
GRUPPO TERMICO Maggiorato	CYLINDER KIT BIG BORE	CYLINDRE COMPLET Majoré				
KIT CUSCINETTI PARAOLI DI BANCO Serie	BEARINGS AND OIL SEALS KIT	KIT PALIERS JOINTS D'HUILE DE VILEBREQUIN Jeu				
KIT REVISIONE POMPA ACQUA	WATER PUMP REPAIR KIT	KIT RÉVISION POMPE À EAU		AA00815	AA00815	AA00815
KIT TAGLIANDO	SERVICE KIT	KIT COUPON				
MASSE CENTRIFUGHE PESO ORIGINALE	ROLLER WEIGHTS Standard weight	MASSELOTTE CENTRIFUGES POIDS D'ORIGINE		9916710		
MEMBRANA CARBURATORE TIPO ORIGINALE	CARBURETOR DIAPHRAGM OEM	MEMBRANE CARBURATEUR TYPE ORIGINAL				
MEMBRANA CARBURATORE ADATTABILE	CARBURETOR DIAPHRAGM Adaptable	MEMBRANE CARBURATEUR ADAPTABLE				
MOLLE CONTRASTO VARIATORE	REAR VARIATOR SPRING	RESSORTS CONTRASTE VARIATEUR				
MOLLA A GAS PER SELIA	SEAT GAS SPRING	RESSORT À GAZ POUR SELLE				
MOTORINO D'AVVIAMENTO	STARTER ENGINE	DÉMARREUR ÉLECTRIQUE		MA00007	MA00007	MA00007
PIATTELLO PORTATASSELI	VARIATOR SLIDERS	CURSEURS VARIATEUR				
POMPA BENZINA	FUEL PUMP	POMPE À ESSENCE				
PULEGGIA FISSA	FIXED SHEAVE	POULIE FIXE				
REGOLATORE DI TENSIONE	RECTIFIER	RÉGULATEUR DE TENSION		RE00026	RE00026	RE00026
RUOTA LIBERA Completa	STARTER CLUTCH SET	ROUE LIBRE Complète				
RUOTA LIBERA RL + flangia	STARTER CLUTCH + FLANGE	ROUE LIBRE RL + flasque		RL00006	RL00006	RL00006
RUOTA LIBERA RL nuda	STARTER CLUTCH	ROUE LIBRE RL nue				
RUOTA LIBERA Ingranaggio	STARTER CLUTCH GEAR	ROUE LIBRE Engrenage		RL00007	RL00007	RL00007
RUOTA LIBERA Flangia	STARTER CLUTCH FLANGE	ROUE LIBRE Flasque				
SERIE DISCHI FRIZIONE	CLUTCH PLATES KIT	JEU DISQUES EMBRAYAGE				
STATORE	STATOR	STATOR				
TASSELLI TRAINO	VARIATOR SLIDERS	CURSEURS VARIATEUR				
VARIATORE VARIOTOP TPR	VARIOTOP TPR	VARIOTOP TPR				

KYMCO	KYMCO	KYMCO	KYMCO	KYMCO	KYMCO	KYMCO	KYMCO	KYMCO	KYMCO	KYMCO	KYMCO
DINK CLASSIC	DINK CLASSIC EU2	DINK CLASSIC EU2	DINK EU3	DINK IE EU3	DINK LX	DINK LX	DOWNTOWN ABS	DOWNTOWN ABS E4	DOWNTOWN E4	DOWNTOWN I	DOWNTOWN I
04-04	03-03	03-03	06-07	06-07	98-00	98-00	10-10	16-16	16-16	09-16	10-10
200cc 4T LC	125cc 4T LC	150cc 4T LC	125cc 4T LC	200cc 4T LC	125cc 4T LC	150cc 4T LC	300cc 4T LC	350cc 4T LC	125cc 4T LC	125cc 4T LC	200cc 4T LC
							FZ00408				FZ00408
	9915220	9915220	9915220	9926420	9915220	9915220					
	9935660	9935660	9935660		9935660	9935660	9935320	9935320	9935310	9935310	9935330
							FZ00409			FZ00411	FZ00409
AA00815	AA00815	AA00815			AA00815	AA00815	AA00833			AA00835	AA00833
										9917640	
			MC12103								
							9980230	9980230	9980230	9980230	9980230
MA00007	MA00007	MA00007	MA00027		MA00007	MA00007					
RE00026	RE00026	RE00026	RE00028	RE00028	RE00026	RE00026	RE00028			RE00028	RE00028
RL00008	RL00006	RL00006	RL00006	RL00008 RL00028	RL00006	RL00006	RL00028	RL00028	RL00006	RL00006	RL00028
	RL00007	RL00007			RL00007	RL00007					

MAXI SCOOTER

KYMCO	KYMCO	KYMCO	KYMCO
DOWNTOWN I	DOWNTOWN I	DOWNTOWN I ABS	DOWNTOWN I ABS
09-09	11-11	11-16	15-15
300cc 4T LC	300cc 4T LC	300cc 4T LC	350cc 4T LC

IT	EN	FR				
ALBERO A CAMME	CAM SHAFT	ARBRE À CAMES				
ALBERO MOTORE Sel 1/Sel 2	CRANKSHAFT Sel 1/Sel 2	VILEBREQUIN Sel 1/ Sel 2				
CAMPANA FRIZIONE	CLUTCH HOUSING	CLOCHE EMBRAYAGE		FZ00408	FZ00408	FZ00408
CINGHIA DI TRASMISSIONE Bando	TRANSMISSION BELT Bando	COURROIE DE TRANSMISSION Bando				
CINGHIA DI TRASMISSIONE Mitsuboshi	TRANSMISSION BELT Mitsuboshi	COURROIE DE TRANSMISSION Mitsuboshi		9935320	9935320	9935320
CINGHIA DI TRASMISSIONE Altro	TRANSMISSION BELT Other	COURROIE DE TRANSMISSION Autres				
COLLETTORE ASPIRAZIONE	INLET MANIFOLD	COLLECTEUR ASPIRATION				
COLLETTORE ASPIRAZIONE SX	INLET MANIFOLD LEFT	COLLECTEUR ASPIRATION GAUCHE				
COLLETTORE ASPIRAZIONE DX	INLET MANIFOLD RIGHT	COLLECTEUR ASPIRATION DROITE				
FILTRO OLIO	OIL FILTER	FILTRE À HUILE				
FRIZIONE	CLUTCH	EMBRAYAGE		FZ00409	FZ00409	FZ00409
GRUPPO TERMICO Standard	CYLINDER KIT Ø standard	CYLINDRE COMPLET Standard				
GRUPPO TERMICO Maggiorato	CYLINDER KIT BIG BORE	CYLINDRE COMPLET Majoré				
KIT CUSCINETTI PARAOLI DI BANCO Serie	BEARINGS AND OIL SEALS KIT	KIT PALIERS JOINTS D'HUILE DE VILEBREQUIN Jeu				
KIT REVISIONE POMPA ACQUA	WATER PUMP REPAIR KIT	KIT RÉVISION POMPE À EAU		AA00833	AA00833	AA00833
KIT TAGLIANDO	SERVICE KIT	KIT COUPON				
MASSE CENTRIFUGHE PESO ORIGINALE	ROLLER WEIGHTS Standard weight	MASSELOTES CENTRIFUGES POIDS D'ORIGINE				
MEMBRANA CARBURATORE TIPO ORIGINALE	CARBURETOR DIAPHRAGM OEM	MEMBRANE CARBURATEUR TYPE ORIGINAL				
MEMBRANA CARBURATORE ADATTABILE	CARBURETOR DIAPHRAGM Adaptable	MEMBRANE CARBURATEUR ADAPTABLE				
MOLLE CONTRASTO VARIATORE	REAR VARIATOR SPRING	RESSORTS CONTRASTE VARIATEUR				
MOLLA A GAS PER SELIA	SEAT GAS SPRING	RESSORT À GAZ POUR SELLE		9980230	9980230	9980230
MOTORINO D'AVVIAMENTO	STARTER ENGINE	DÉMARREUR ÉLECTRIQUE				
PIATTELLO PORTATASSELI	VARIATOR SLIDERS	CURSEURS VARIATEUR				
POMPA BENZINA	FUEL PUMP	POMPE À ESSENCE				
PULEGGIA FISSA	FIXED SHEAVE	POULIE FIXE				
REGOLATORE DI TENSIONE	RECTIFIER	RÉGULATEUR DE TENSION		RE00028	RE00028	RE00028
RUOTA LIBERA Completa	STARTER CLUTCH SET	ROUE LIBRE Complète				
RUOTA LIBERA RL + flangia	STARTER CLUTCH + FLANGE	ROUE LIBRE RL + flasque		RL00028	RL00028	RL00028
RUOTA LIBERA RL nuda	STARTER CLUTCH	ROUE LIBRE RL nue				
RUOTA LIBERA Ingranaggio	STARTER CLUTCH GEAR	ROUE LIBRE Engrenage				
RUOTA LIBERA Flangia	STARTER CLUTCH FLANGE	ROUE LIBRE Flasque				
SERIE DISCHI FRIZIONE	CLUTCH PLATES KIT	JEU DISQUES EMBRAYAGE				
STATORE	STATOR	STATOR				
TASSELLI TRAINO	VARIATOR SLIDERS	CURSEURS VARIATEUR				
VARIATORE VARIOTOP TPR	VARIOTOP TPR	VARIOTOP TPR				

KYMCO	KYMCO	KYMCO	KYMCO	KYMCO	KYMCO	KYMCO	KYMCO	KYMCO	KYMCO	KYMCO	KYMCO
G-DINK	G-DINK	G-DINK I ABS E4	GRAND DINK	GRAND DINK	GRAND DINK	GRAND DINK EU2	GRAND DINK EU2	GRAND DINK EU2	HEROISM	HEROISM	K-XCT I
12-12	12-12	17-17	01-02	01-02	01-02	03-04	03-04	03-04	95-97	95-97	12-14
125cc 4T LC	300cc 4T-2V LC	300cc 4T-2V LC	125cc 4T LC	150cc 4T LC	250cc 4T LC	125cc 4T LC	150cc 4T LC	250cc 4T LC	125cc 4T AC	150cc 4T AC	125cc 4T LC
					IM07057			IM07057			
	FZ00399	FZ00399			FZ00399			FZ00399	FZ00375	FZ00375	FZ00375
			9915220	9915220		9915220	9915220		9915640	9915640	
	9935910	9935910	9935660	9935660		9935660	9935660				9935310
					9922420			9922420			
					FZ00400			FZ00400	FZ00386	FZ00386	FZ00386
			AA00815	AA00815	AA00816	AA00815	AA00815	AA00816			
			9924320		9916080			9916080	9917640		
MA00027	MA00031		MA00027	MA00027	MA00031	MA00027	MA00027	MA00031	MA00007	MA00007	
			RE00026	RE00026	RE00026	RE00026	RE00026	RE00026	RE00026	RE00026	
RL00028	RL00028		RL00006	RL00006	RL00008	RL00006	RL00006	RL00008			RL00006
			RL00007	RL00007	RL00009			RL00009	RL00024	RL00024	
					9923670						

MAXI SCOOTER

TOP
- performances -



KYMCO	KYMCO	KYMCO	KYMCO
K-XCT I	K-XCT I ABS	LIKE	LIKE IE
12-12	14-14	09-09	09-09
300cc 4T LC	300cc 4T LC	125cc 4T AC	200cc 4T AC

IT	EN	FR				
ALBERO A CAMME	CAM SHAFT	ARBRE À CAMES				
ALBERO MOTORE Sel 1/Sel 2	CRANKSHAFT Sel 1/Sel 2	VILEBREQUIN Sél 1/ Sél 2				IM07071
CAMPANA FRIZIONE	CLUTCH HOUSING	CLOCHE EMBRAYAGE				FZ00375 FZ00375
CINGHIA DI TRASMISSIONE Bando	TRANSMISSION BELT Bando	COURROIE DE TRANSMISSION Bando				9926430 9926430
CINGHIA DI TRASMISSIONE Mitsuboshi	TRANSMISSION BELT Mitsuboshi	COURROIE DE TRANSMISSION Mitsuboshi		9935320	9935320	9935740
CINGHIA DI TRASMISSIONE Altro	TRANSMISSION BELT Other	COURROIE DE TRANSMISSION Autres				
COLLETTORE ASPIRAZIONE	INLET MANIFOLD	COLLECTEUR ASPIRATION				
COLLETTORE ASPIRAZIONE SX	INLET MANIFOLD LEFT	COLLECTEUR ASPIRATION GAUCHE				
COLLETTORE ASPIRAZIONE DX	INLET MANIFOLD RIGHT	COLLECTEUR ASPIRATION DROITE				
FILTRO OLIO	OIL FILTER	FILTRE À HUILE				
FRIZIONE	CLUTCH	EMBRAYAGE				FZ00386 FZ00386
GRUPPO TERMICO Standard	CYLINDER KIT Ø standard	CYLINDRE COMPLET Standard				9936400
GRUPPO TERMICO Maggiorato	CYLINDER KIT BIG BORE	CYLINDRE COMPLET Majoré				9936400
KIT CUSCINETTI PARAOLI DI BANCO Serie	BEARINGS AND OIL SEALS KIT	KIT PALIERS JOINTS D'HUILE DE VILEBREQUIN Jeu				
KIT REVISIONE POMPA ACQUA	WATER PUMP REPAIR KIT	KIT RÉVISION POMPE À EAU				
KIT TAGLIANDO	SERVICE KIT	KIT COUPON				
MASSE CENTRIFUGHE PESO ORIGINALE	ROLLER WEIGHTS Standard weight	MASSELOTTE CENTRIFUGES POIDS D'ORIGINE				
MEMBRANA CARBURATORE TIPO ORIGINALE	CARBURETOR DIAPHRAGM OEM	MEMBRANE CARBURATEUR TYPE ORIGINAL				
MEMBRANA CARBURATORE ADATTABILE	CARBURETOR DIAPHRAGM Adaptable	MEMBRANE CARBURATEUR ADAPTABLE				MC12103
MOLLE CONTRASTO VARIATORE	REAR VARIATOR SPRING	RESSORTS CONTRASTE VARIATEUR				
MOLLA A GAS PER SELIA	SEAT GAS SPRING	RESSORT À GAZ POUR SELLE				
MOTORINO D'AVVIAMENTO	STARTER ENGINE	DÉMARREUR ÉLECTRIQUE				MA00007 MA00007
PIATTELLO PORTATASSELI	VARIATOR SLIDERS	CURSEURS VARIATEUR				
POMPA BENZINA	FUEL PUMP	POMPE À ESSENCE				
PULEGGIA FISSA	FIXED SHEAVE	POULIE FIXE				PL04074 PL04074
REGOLATORE DI TENSIONE	RECTIFIER	RÉGULATEUR DE TENSION				RE00019
RUOTA LIBERA Completa	STARTER CLUTCH SET	ROUE LIBRE Complète				
RUOTA LIBERA RL + flangia	STARTER CLUTCH + FLANGE	ROUE LIBRE RL + flasque		RL00028	RL00028	
RUOTA LIBERA RL nuda	STARTER CLUTCH	ROUE LIBRE RL nue				
RUOTA LIBERA Ingranaggio	STARTER CLUTCH GEAR	ROUE LIBRE Engrenage				
RUOTA LIBERA Flangia	STARTER CLUTCH FLANGE	ROUE LIBRE Flasque				
SERIE DISCHI FRIZIONE	CLUTCH PLATES KIT	JEU DISQUES EMBRAYAGE				
STATORE	STATOR	STATOR				ST00025
TASSELLI TRAINO	VARIATOR SLIDERS	CURSEURS VARIATEUR				
VARIATORE VARIOTOP TPR	VARIOTOP TPR	VARIOTOP TPR				9927830

KYMCO	KYMCO	KYMCO	KYMCO	KYMCO	KYMCO	KYMCO	KYMCO	KYMCO	KYMCO	KYMCO	KYMCO
LIKE LX	LIKE LX	MOVIE	MOVIE EU3	MOVIE EU3	MOVIE XL	MOVIE XL	MOVIE XL EU2	MOVIE XL EU2	MYROAD I	PEOPLE	PEOPLE
12-12	12-12	99-00	06-07	06-07	01-01	01-01	03-04	03-04	11-16	99-00	99-00
125cc 4T AC	200cc 4T AC	125cc 4T AC	125cc 4T AC	150cc 4T AC	125cc 4T AC	150cc 4T AC	125cc 4T AC	150cc 4T AC	700cc 4T LC	125cc 4T AC	150cc 4T AC
IM07071		IM07071	IM07071		IM07071	IM07071	IM07071	IM07071		IM07071	IM07071
	FZ00375	FZ00375	FZ00375	FZ00375	FZ00375	FZ00375	FZ00375	FZ00375		FZ00375	FZ00375
	9926430	9915640	9926430	9926430	9926430	9926430	9926430	9926430		9926430	9926430
9935740			9935740	9935740	9935740	9935740	9935740	9935740	9935890	9935740	9935740
	FZ00386	FZ00386	FZ00386	FZ00386	FZ00386	FZ00386	FZ00386	FZ00386		FZ00386	FZ00386
9936400		9936400	9936400		9936400	9936400	9936400	9936400		9936400	9936400
9936400		9936400	9936400		9936400	9936400	9936400	9936400		9936400	9936400
										TG00103	TG00103
		9917640								9917640	
	MC12103		MC12103	MC12103			MC12103	MC12103			
	MA00007	MA00007	MA00007	MA00007			MA00007	MA00007		MA00007	MA00007
PL04074	PL04074	PL04074	PL04074	PL04074	PL04074	PL04074	PL04074	PL04074		PL04074	PL04074
	RE00019	RE00013	RE00013	RE00013	RE00013	RE00013	RE00013	RE00013		RE00013	RE00013
			RL00025	RL00025						RL00025	RL00025
			RL00024	RL00024						RL00024	RL00024
ST00025										ST00027	ST00027
	9927830		9927830							9927830	9927830

MAXI SCOOTER

MAXI SCOOTER

TOP
- performances -



KYMCO	KYMCO	KYMCO	KYMCO
PEOPLE EU2	PEOPLE EU2	PEOPLE EU3	PEOPLE EU3
03-03	03-03	07-07	08-08
125cc 4T AC	150cc 4T AC	125cc 4T AC	125cc 4T AC

IT	EN	FR				
ALBERO A CAMME	CAM SHAFT	ARBRE À CAMES				
ALBERO MOTORE Sel 1/Sel 2	CRANKSHAFT Sel 1/Sel 2	VILEBREQUIN Sel 1/ Sel 2		IM07071	IM07071	IM07071
CAMPANA FRIZIONE	CLUTCH HOUSING	CLOCHE EMBRAYAGE			FZ00375	FZ00375
CINGHIA DI TRASMISSIONE Bando	TRANSMISSION BELT Bando	COURROIE DE TRANSMISSION Bando		9926430	9926430	9926430
CINGHIA DI TRASMISSIONE Mitsuboshi	TRANSMISSION BELT Mitsuboshi	COURROIE DE TRANSMISSION Mitsuboshi		9935740	9935740	9935740
CINGHIA DI TRASMISSIONE Altro	TRANSMISSION BELT Other	COURROIE DE TRANSMISSION Autres				
COLLETTORE ASPIRAZIONE	INLET MANIFOLD	COLLECTEUR ASPIRATION				
COLLETTORE ASPIRAZIONE SX	INLET MANIFOLD LEFT	COLLECTEUR ASPIRATION GAUCHE				
COLLETTORE ASPIRAZIONE DX	INLET MANIFOLD RIGHT	COLLECTEUR ASPIRATION DROITE				
FILTRO OLIO	OIL FILTER	FILTRE À HUILE				
FRIZIONE	CLUTCH	EMBAYAGE		FZ00386	FZ00386	FZ00386
GRUPPO TERMICO Standard	CYLINDER KIT Ø standard	CYLINDRE COMPLET Standard		9936400	9936400	9936400
GRUPPO TERMICO Maggiorato	CYLINDER KIT BIG BORE	CYLINDRE COMPLET Majoré		9936400	9936400	9936400
KIT CUSCINETTI PARAOLI DI BANCO Serie	BEARINGS AND OIL SEALS KIT	KIT PALIERS JOINTS D'HUILE DE VILEBREQUIN Jeu				
KIT REVISIONE POMPA ACQUA	WATER PUMP REPAIR KIT	KIT RÉVISION POMPE À EAU				
KIT TAGLIANDO	SERVICE KIT	KIT COUPON		TG00103	TG00103	TG00103
MASSE CENTRIFUGHE PESO ORIGINALE	ROLLER WEIGHTS Standard weight	MASSELOTES CENTRIFUGES POIDS D'ORIGINE		9917640		9917640
MEMBRANA CARBURATORE TIPO ORIGINALE	CARBURETOR DIAPHRAGM OEM	MEMBRANE CARBURATEUR TYPE ORIGINAL				
MEMBRANA CARBURATORE ADATTABILE	CARBURETOR DIAPHRAGM Adaptable	MEMBRANE CARBURATEUR ADAPTABLE		MC12103	MC12103	MC12103
MOLLE CONTRASTO VARIATORE	REAR VARIATOR SPRING	RESSORTS CONTRASTE VARIATEUR				
MOLLA A GAS PER SELIA	SEAT GAS SPRING	RESSORT À GAZ POUR SELLE				
MOTORINO D'AVVIAMENTO	STARTER ENGINE	DÉMARREUR ÉLECTRIQUE		MA00007	MA00007	MA00007
PIATTELLO PORTATASSELI	VARIATOR SLIDERS	CURSEURS VARIATEUR				
POMPA BENZINA	FUEL PUMP	POMPE À ESSENCE				
PULEGGIA FISSA	FIXED SHEAVE	POULIE FIXE		PL04074	PL04074	PL04074
REGOLATORE DI TENSIONE	RECTIFIER	RÉGULATEUR DE TENSION		RE00013	RE00013	RE00013
RUOTA LIBERA Completa	STARTER CLUTCH SET	ROUE LIBRE Complète				
RUOTA LIBERA RL + flangia	STARTER CLUTCH + FLANGE	ROUE LIBRE RL + flasque				RL00025
RUOTA LIBERA RL nuda	STARTER CLUTCH	ROUE LIBRE RL nue				
RUOTA LIBERA Ingranaggio	STARTER CLUTCH GEAR	ROUE LIBRE Engrenage				RL00024
RUOTA LIBERA Flangia	STARTER CLUTCH FLANGE	ROUE LIBRE Flasque				
SERIE DISCHI FRIZIONE	CLUTCH PLATES KIT	JEU DISQUES EMBRAYAGE				
STATORE	STATOR	STATOR		ST00027	ST00027	ST00027
TASSELLI TRAINO	VARIATOR SLIDERS	CURSEURS VARIATEUR				
VARIATORE VARIOTOP TPR	VARIOTOP TPR	VARIOTOP TPR				9927830

KYMCO	KYMCO	KYMCO	KYMCO	KYMCO	KYMCO	KYMCO	KYMCO	KYMCO	KYMCO	KYMCO	KYMCO
PEOPLE EU3	PEOPLE GTI	PEOPLE GTI	PEOPLE GTI	PEOPLE GTI	PEOPLE GTI	PEOPLE GTI	PEOPLE GTI	PEOPLE GTI ABS	PEOPLE GTI ABS	PEOPLE GTI ABS E4	PEOPLE LC
11-11	10-10	14-14	10-10	14-14	10-10	11-11	14-14	12-12	14-14	16-16	03-04
125cc 4T AC	125cc 4T LC	125cc 4T LC	200cc 4T LC	200cc 4T LC	300cc 4T LC	300cc 4T LC	300cc 4T LC	300cc 4T LC	300cc 4T LC	300cc 4T LC	250cc 4T LC
IM07071											IM07057
FZ00375			FZ00408	FZ00399	FZ00408	FZ00408					FZ00399
9926430											
9935740	9935310	9935310	9935330	9935330	9935320	9935320	9935320	9935320	9935320	9935320	9935280
FZ00386			FZ00409		FZ00409	FZ00409					FZ00400
9936400											
9936400											
			AA00833		AA00833	AA00833					AA00816
TG00103											
9917640	9917640										9916080
MC12103											
MA00007											MA00031
PL04074											
	RE00028	RE00028	RE00028	RE00028	RE00028	RE00028	RE00028	RE00028	RE00028	RE00028	RE00026
	RL00006	RL00006	RL00028	RL00028	RL00028	RL00028	RL00028	RL00028	RL00028	RL00028	RL00008
											RL00009
ST00027											
											9923670

MAXI SCOOTER

MAXI SCOOTER

TOP
- performances -



KYMCO	KYMCO	KYMCO	KYMCO
PEOPLE ONE E4	PEOPLE ONE I	PEOPLE ONE I	PEOPLE ONE I DD
16-16	13-13	13-13	15-15
125cc 4T AC	125cc 4T AC	125cc 4T AC	125cc 4T AC

IT	EN	FR				
ALBERO A CAMME	CAM SHAFT	ARBRE À CAMES				
ALBERO MOTORE Sel 1/Sel 2	CRANKSHAFT Sel 1/Sel 2	VILEBREQUIN Sel 1/ Sel 2		IM07071	IM07071	IM07071
CAMPANA FRIZIONE	CLUTCH HOUSING	CLOCHE EMBRAYAGE			FZ00375	
CINGHIA DI TRASMISSIONE Bando	TRANSMISSION BELT Bando	COURROIE DE TRANSMISSION Bando		9935740		9935740
CINGHIA DI TRASMISSIONE Mitsuboshi	TRANSMISSION BELT Mitsuboshi	COURROIE DE TRANSMISSION Mitsuboshi				9935740
CINGHIA DI TRASMISSIONE Altro	TRANSMISSION BELT Other	COURROIE DE TRANSMISSION Autres				9935740
COLLETTORE ASPIRAZIONE	INLET MANIFOLD	COLLECTEUR ASPIRATION				
COLLETTORE ASPIRAZIONE SX	INLET MANIFOLD LEFT	COLLECTEUR ASPIRATION GAUCHE				
COLLETTORE ASPIRAZIONE DX	INLET MANIFOLD RIGHT	COLLECTEUR ASPIRATION DROITE				
FILTRO OLIO	OIL FILTER	FILTRE À HUILE				
FRIZIONE	CLUTCH	EMBRAYAGE			FZ00386	
GRUPPO TERMICO Standard	CYLINDER KIT Ø standard	CYLINDRE COMPLET Standard		9936400		9936400
GRUPPO TERMICO Maggiorato	CYLINDER KIT BIG BORE	CYLINDRE COMPLET Majoré		9936400		9936400
KIT CUSCINETTI PARAOLI DI BANCO Serie	BEARINGS AND OIL SEALS KIT	KIT PALIERS JOINTS D'HUILE DE VILEBREQUIN Jeu				
KIT REVISIONE POMPA ACQUA	WATER PUMP REPAIR KIT	KIT RÉVISION POMPE À EAU				
KIT TAGLIANDO	SERVICE KIT	KIT COUPON		TG00103		TG00103
MASSE CENTRIFUGHE PESO ORIGINALE	ROLLER WEIGHTS Standard weight	MASSELOTTE CENTRIFUGES POIDS D'ORIGINE				
MEMBRANA CARBURATORE TIPO ORIGINALE	CARBURETOR DIAPHRAGM OEM	MEMBRANE CARBURATEUR TYPE ORIGINAL				
MEMBRANA CARBURATORE ADATTABILE	CARBURETOR DIAPHRAGM Adaptable	MEMBRANE CARBURATEUR ADAPTABLE				
MOLLE CONTRASTO VARIATORE	REAR VARIATOR SPRING	RESSORTS CONTRASTE VARIATEUR				
MOLLA A GAS PER SELIA	SEAT GAS SPRING	RESSORT À GAZ POUR SELLE				
MOTORINO D'AVVIAMENTO	STARTER ENGINE	DÉMARREUR ÉLECTRIQUE				
PIATTELLO PORTATASSELI	VARIATOR SLIDERS	CURSEURS VARIATEUR				
POMPA BENZINA	FUEL PUMP	POMPE À ESSENCE				
PULEGGIA FISSA	FIXED SHEAVE	POULIE FIXE		PL04074		PL04074
REGOLATORE DI TENSIONE	RECTIFIER	RÉGULATEUR DE TENSION				
RUOTA LIBERA Completa	STARTER CLUTCH SET	ROUE LIBRE Complète				
RUOTA LIBERA RL + flangia	STARTER CLUTCH + FLANGE	ROUE LIBRE RL + flasque				
RUOTA LIBERA RL nuda	STARTER CLUTCH	ROUE LIBRE RL nue				
RUOTA LIBERA Ingranaggio	STARTER CLUTCH GEAR	ROUE LIBRE Engrenage				
RUOTA LIBERA Flangia	STARTER CLUTCH FLANGE	ROUE LIBRE Flasque				
SERIE DISCHI FRIZIONE	CLUTCH PLATES KIT	JEU DISQUES EMBRAYAGE				
STATORE	STATOR	STATOR				
TASSELLI TRAINO	VARIATOR SLIDERS	CURSEURS VARIATEUR				
VARIATORE VARIOTOP TPR	VARIOTOP TPR	VARIOTOP TPR				

KYMCO	KYMCO	KYMCO	KYMCO	KYMCO	KYMCO	KYMCO	KYMCO	KYMCO	KYMCO	KYMCO	KYMCO
PEOPLE S	PEOPLE S	PEOPLE S	PEOPLE S DD EU3	PEOPLE S I	PEOPLE S I	PEOPLE S I	SUPER 8	SUPER 8	VIVIO	VIVIO	X CITING
05-05	05-05	06-06	07-08	07-07	07-07	08-08	08-08	09-09	00-00	00-00	05-05
125cc 4T AC	200cc 4T AC	250cc 4T LC	125cc 4T AC	200cc 4T AC	250cc 4T LC	300cc 4T LC	125cc 4T AC	125cc 4T AC	125cc 4T AC	150cc 4T AC	250cc 4T LC
						(BB60)	(KL25)	(KL25)			
IM07071		IM07057	IM07071		IM07057		IM07071	IM07071	IM07071	IM07071	IM07057
FZ00375	FZ00375	FZ00399	FZ00375	FZ00375			FZ00375	FZ00375	FZ00375	FZ00375	FZ00399
9926430	9926430		9926430	9926430			9926430	9926430	9915640	9915640	
9935740		9935280	9935740		9935280	9935280	9935740	9935740			9935280
							CT00742	CT00742			
FZ00386	FZ00386	FZ00400	FZ00386	FZ00386	FZ00400	FZ00400	FZ00386	FZ00386	FZ00386	FZ00386	FZ00400
9936400			9936400				9936400	9936400	9936400	9936400	
9936400			9936400				9936400	9936400	9936400	9936400	
		AA00816			AA00816	AA00816					AA00816
TG00103			TG00103				TG00103	TG00103			
9917640	9917640	9916080	9917640	9917640	9916080	9932390	9917640	9917640	9917640		9916080
MC12103	MC12103		MC12103				MC12103				
MA00007	MA00007	MA00031	MA00007	MA00007	MA00031	MA00031	MA00007	MA00007	MA00007	MA00007	MA00031
PL04074	PL04074		PL04074	PL04074			PL04074	PL04074	PL04074	PL04074	
RE00019	RE00019		RE00019	RE00026	RE00028	RE00028	RE00019	RE00019	RE00013	RE00013	RE00026
RL00025	RL00025	RL00028			RL00028	RL00028	RL00025	RL00025	RL00025	RL00025	RL00028
RL00024	RL00024	RL00031			RL00031	RL00031	RL00024	RL00024	RL00024	RL00024	RL00031
9927830		9923670			9923670		9927830	9927830	9927830	9927830	9923670

MAXI SCOOTER

KYMCO	KYMCO	KYMCO	KYMCO
X CITING	X CITING I	X CITING I	X CITING I
05-05	06-07	08-08	15-15
500cc 4T LC	250cc 4T LC	300cc 4T LC	400cc 4T LC

IT	EN	FR				
ALBERO A CAMME	CAM SHAFT	ARBRE À CAMES				
ALBERO MOTORE Sel 1/Sel 2	CRANKSHAFT Sel 1/Sel 2	VILEBREQUIN Sél 1/ Sél 2			IM07057	
CAMPANA FRIZIONE	CLUTCH HOUSING	CLOCHE EMBRAYAGE			FZ00399	FZ00399
CINGHIA DI TRASMISSIONE Bando	TRANSMISSION BELT Bando	COURROIE DE TRANSMISSION Bando				9929770
CINGHIA DI TRASMISSIONE Mitsuboshi	TRANSMISSION BELT Mitsuboshi	COURROIE DE TRANSMISSION Mitsuboshi		9935290	9935300	9935900
CINGHIA DI TRASMISSIONE Altro	TRANSMISSION BELT Other	COURROIE DE TRANSMISSION Autres				
COLLETTORE ASPIRAZIONE	INLET MANIFOLD	COLLECTEUR ASPIRATION				
COLLETTORE ASPIRAZIONE SX	INLET MANIFOLD LEFT	COLLECTEUR ASPIRATION GAUCHE				
COLLETTORE ASPIRAZIONE DX	INLET MANIFOLD RIGHT	COLLECTEUR ASPIRATION DROITE				
FILTRO OLIO	OIL FILTER	FILTRE À HUILE				
FRIZIONE	CLUTCH	EMBRAYAGE			FZ00400	FZ00400
GRUPPO TERMICO Standard	CYLINDER KIT Ø standard	CYLINDRE COMPLET Standard				
GRUPPO TERMICO Maggiorato	CYLINDER KIT BIG BORE	CYLINDRE COMPLET Majoré				
KIT CUSCINETTI PARAOLI DI BANCO Serie	BEARINGS AND OIL SEALS KIT	KIT PALIERS JOINTS D'HUILE DE VILEBREQUIN Jeu				
KIT REVISIONE POMPA ACQUA	WATER PUMP REPAIR KIT	KIT RÉVISION POMPE À EAU		AA00840	AA00816	AA00816 AA00837
KIT TAGLIANDO	SERVICE KIT	KIT COUPON				
MASSE CENTRIFUGHE PESO ORIGINALE	ROLLER WEIGHTS Standard weight	MASSELOTTE CENTRIFUGES POIDS D'ORIGINE			9916080	9932390
MEMBRANA CARBURATORE TIPO ORIGINALE	CARBURETOR DIAPHRAGM OEM	MEMBRANE CARBURATEUR TYPE ORIGINAL				
MEMBRANA CARBURATORE ADATTABILE	CARBURETOR DIAPHRAGM Adaptable	MEMBRANE CARBURATEUR ADAPTABLE				
MOLLE CONTRASTO VARIATORE	REAR VARIATOR SPRING	RESSORTS CONTRASTE VARIATEUR				
MOLLA A GAS PER SELIA	SEAT GAS SPRING	RESSORT À GAZ POUR SELLE				
MOTORINO D'AVVIAMENTO	STARTER ENGINE	DÉMARREUR ÉLECTRIQUE			MA00031	MA00031
PIATTELLO PORTATASSELI	VARIATOR SLIDERS	CURSEURS VARIATEUR				
POMPA BENZINA	FUEL PUMP	POMPE À ESSENCE				
PULEGGIA FISSA	FIXED SHEAVE	POULIE FIXE				
REGOLATORE DI TENSIONE	RECTIFIER	RÉGULATEUR DE TENSION		RE00028	RE00028	RE00028
RUOTA LIBERA Completa	STARTER CLUTCH SET	ROUE LIBRE Complète				
RUOTA LIBERA RL + flangia	STARTER CLUTCH + FLANGE	ROUE LIBRE RL + flasque		RL00027	RL00028	RL00028
RUOTA LIBERA RL nuda	STARTER CLUTCH	ROUE LIBRE RL nue				
RUOTA LIBERA Ingranaggio	STARTER CLUTCH GEAR	ROUE LIBRE Engrenage		RL00026	RL00031	RL00031
RUOTA LIBERA Flangia	STARTER CLUTCH FLANGE	ROUE LIBRE Flasque				
SERIE DISCHI FRIZIONE	CLUTCH PLATES KIT	JEU DISQUES EMBRAYAGE				
STATORE	STATOR	STATOR				
TASSELLI TRAINO	VARIATOR SLIDERS	CURSEURS VARIATEUR				
VARIATORE VARIOTOP TPR	VARIOTOP TPR	VARIOTOP TPR			9923670	9932860

KYMCO	KYMCO	KYMCO	KYMCO	KYMCO	KYMCO	KYMCO	KYMCO	KYMCO	KYMCO	KYMCO	KYMCO
X CITING I	X CITING I	X CITING I ABS	X CITING I ABS	X CITING I ABS E4	X CITING I ABS E4	X CITING I R	X CITING I R	X CITING I R	X CITING R	X-TOWN CBS	XCITING I
06-07	08-08	14-14	15-15	16-16	17-17	08-08	09-09	07-08	09-09	16-16	13-13
500cc 4T LC (SAA0)	500cc 4T LC	400cc 4T LC	400cc 4T LC	400cc 4T LC	400cc 4T LC	300cc 4T LC	300cc 4T LC	500cc 4T LC	500cc 4T LC	125cc 4T-4V LC	400cc 4T LC
						FZ00399	FZ00399				
						9929770	9929770				
9935290	9935290	9935900	9935900	9935900	9935900			9935290	9935290	9935310	9935900
						FZ00400	FZ00400				
AA00840	AA00840	AA00837	AA00837			AA00816	AA00816	AA00840	AA00840		AA00837
						9932390	9932390				
						MA00031	MA00031				
						RE00028	RE00028				
RL00027	RL00027					RL00028	RL00028	RL00027	RL00027	RL00006	
RL00026	RL00026					RL00031	RL00031	RL00026	RL00026		
		9932860	9932860								9932860

MAXI SCOOTER

MAXI SCOOTER

TOP
- performances -



KYMCO	MALAGUTI	MALAGUTI	MALAGUTI
YUP	BLOG	BLOG	BLOG IE
03-03	11-11	11-11	09-10
250cc 4T LC (SH50D)	125cc 4T LC	160cc 4T LC	125cc 4T LC

IT	EN	FR				
ALBERO A CAMME	CAM SHAFT	ARBRE À CAMES				
ALBERO MOTORE Sel 1/Sel 2	CRANKSHAFT Sel 1/Sel 2	VILEBREQUIN Sél 1/ Sél 2		IM07057		
CAMPANA FRIZIONE	CLUTCH HOUSING	CLOCHE EMBRAYAGE		FZ00399		FZ00375
CINGHIA DI TRASMISSIONE Bando	TRANSMISSION BELT Bando	COURROIE DE TRANSMISSION Bando				
CINGHIA DI TRASMISSIONE Mitsuboshi	TRANSMISSION BELT Mitsuboshi	COURROIE DE TRANSMISSION Mitsuboshi		9935770	9935770	9935770
CINGHIA DI TRASMISSIONE Altro	TRANSMISSION BELT Other	COURROIE DE TRANSMISSION Autres		9922420	9923140	9923140
COLLETTORE ASPIRAZIONE	INLET MANIFOLD	COLLECTEUR ASPIRATION				
COLLETTORE ASPIRAZIONE SX	INLET MANIFOLD LEFT	COLLECTEUR ASPIRATION GAUCHE				
COLLETTORE ASPIRAZIONE DX	INLET MANIFOLD RIGHT	COLLECTEUR ASPIRATION DROITE				
FILTRO OLIO	OIL FILTER	FILTRE À HUILE				
FRIZIONE	CLUTCH	EMBRAYAGE		FZ00400		FZ00386
GRUPPO TERMICO Standard	CYLINDER KIT Ø standard	CYLINDRE COMPLET Standard				
GRUPPO TERMICO Maggiorato	CYLINDER KIT BIG BORE	CYLINDRE COMPLET Majoré				
KIT CUSCINETTI PARAOLI DI BANCO Serie	BEARINGS AND OIL SEALS KIT	KIT PALIERS JOINTS D'HUILE DE VILEBREQUIN Jeu				
KIT REVISIONE POMPA ACQUA	WATER PUMP REPAIR KIT	KIT RÉVISION POMPE À EAU		AA00816		
KIT TAGLIANDO	SERVICE KIT	KIT COUPON				
MASSE CENTRIFUGHE PESO ORIGINALE	ROLLER WEIGHTS Standard weight	MASSELOTTE CENTRIFUGES POIDS D'ORIGINE		9916080		
MEMBRANA CARBURATORE TIPO ORIGINALE	CARBURETOR DIAPHRAGM OEM	MEMBRANE CARBURATEUR TYPE ORIGINAL				
MEMBRANA CARBURATORE ADATTABILE	CARBURETOR DIAPHRAGM Adaptable	MEMBRANE CARBURATEUR ADAPTABLE				
MOLLE CONTRASTO VARIATORE	REAR VARIATOR SPRING	RESSORTS CONTRASTE VARIATEUR				
MOLLA A GAS PER SELIA	SEAT GAS SPRING	RESSORT À GAZ POUR SELLE				
MOTORINO D'AVVIAMENTO	STARTER ENGINE	DÉMARREUR ÉLECTRIQUE		MA00031	MA00022	MA00022 MA00022
PIATTELLO PORTATASSELI	VARIATOR SLIDERS	CURSEURS VARIATEUR				
POMPA BENZINA	FUEL PUMP	POMPE À ESSENCE				
PULEGGIA FISSA	FIXED SHEAVE	POULIE FIXE				
REGOLATORE DI TENSIONE	RECTIFIER	RÉGULATEUR DE TENSION		RE00026		
RUOTA LIBERA Completa	STARTER CLUTCH SET	ROUE LIBRE Complète				
RUOTA LIBERA RL + flangia	STARTER CLUTCH + FLANGE	ROUE LIBRE RL + flasque		RL00008		
RUOTA LIBERA RL nuda	STARTER CLUTCH	ROUE LIBRE RL nue				
RUOTA LIBERA Ingranaggio	STARTER CLUTCH GEAR	ROUE LIBRE Engrenage		RL00009		
RUOTA LIBERA Flangia	STARTER CLUTCH FLANGE	ROUE LIBRE Flasque				
SERIE DISCHI FRIZIONE	CLUTCH PLATES KIT	JEU DISQUES EMBRAYAGE				
STATORE	STATOR	STATOR				
TASSELLI TRAINO	VARIATOR SLIDERS	CURSEURS VARIATEUR				
VARIATORE VARIOTOP TPR	VARIOTOP TPR	VARIOTOP TPR		9923670		

MALAGUTI	MALAGUTI	MALAGUTI	MALAGUTI	MALAGUTI	MALAGUTI	MALAGUTI	MALAGUTI	MALAGUTI	MALAGUTI	MALAGUTI	MALAGUTI
BLOG IE	CENTRO IE EU3	CENTRO IE EU3	CENTRO SL	CENTRO SL	CENTRO SL IE EU3	CENTRO SL IE EU3	CIAK	CIAK	CIAK MASTER	CIAK MASTER	CIAK MASTER EU3
09-10	08-09	08-09	11-11	11-11	09-10	09-10	00-01	00-02	04-04	04-04	06-06
160cc 4T LC	125cc 4T LC	160cc 4T LC	125cc 4T LC	160cc 4T LC	125cc 4T LC	160cc 4T LC	125cc 4T AC	150cc 4T AC	125cc 4T AC	150cc 4T AC	125cc 4T AC
							Kymco	Kymco	Kymco	Kymco	Kymco
FZ00375	FZ00375	FZ00375			FZ00375	FZ00375			FZ00375	FZ00375	
							9926430	9926430	9926430	9926430	9926430
9935770	9935770	9935770	9935770	9935770	9935770	9935770					
9923140	9923140	9923140	9923140	9923140	9923140	9923140					
FZ00386	FZ00386	FZ00386			FZ00386	FZ00386			FZ00386	FZ00386	
							9924320				
MA00022	MA00022	MA00022	MA00022	MA00022	MA00022	MA00022	MA00007	MA00007	MA00007	MA00007	MA00007
							RE00013	RE00013	RE00013	RE00013	RE00019
									RL00025	RL00025	
									RL00024	RL00024	
									9927830	9927830	

MAXI SCOOTER

MAXI SCOOTER

TOP
- performances -



MALAGUTI	MALAGUTI	MALAGUTI	MALAGUTI
CIAK MASTER EURO 2	CIAK RE-STYKING EU2	CIAK RE-STYKING EU2	F18 WARRIOR
06-06	03-03	03-03	00-02
200cc 4T AC	125cc 4T AC	150cc 4T AC	125cc 4T LC
Kymco	Kymco	Kymco	Kymco

IT	EN	FR				
ALBERO A CAMME	CAM SHAFT	ARBRE À CAMES				
ALBERO MOTORE Sel 1/Sel 2	CRANKSHAFT Sel 1/Sel 2	VILEBREQUIN Sel 1/ Sel 2				
CAMPANA FRIZIONE	CLUTCH HOUSING	CLOCHE EMBRAYAGE		FZ00375		
CINGHIA DI TRASMISSIONE Bando	TRANSMISSION BELT Bando	COURROIE DE TRANSMISSION Bando		9926430	9926430	9926430
CINGHIA DI TRASMISSIONE Mitsuboshi	TRANSMISSION BELT Mitsuboshi	COURROIE DE TRANSMISSION Mitsuboshi				9935660
CINGHIA DI TRASMISSIONE Altro	TRANSMISSION BELT Other	COURROIE DE TRANSMISSION Autres				
COLLETTORE ASPIRAZIONE	INLET MANIFOLD	COLLECTEUR ASPIRATION				
COLLETTORE ASPIRAZIONE SX	INLET MANIFOLD LEFT	COLLECTEUR ASPIRATION GAUCHE				
COLLETTORE ASPIRAZIONE DX	INLET MANIFOLD RIGHT	COLLECTEUR ASPIRATION DROITE				
FILTRO OLIO	OIL FILTER	FILTRE À HUILE				
FRIZIONE	CLUTCH	EMBAYAGE		FZ00386		
GRUPPO TERMICO Standard	CYLINDER KIT Ø standard	CYLINDRE COMPLET Standard				
GRUPPO TERMICO Maggiorato	CYLINDER KIT BIG BORE	CYLINDRE COMPLET Majoré				
KIT CUSCINETTI PARAOLI DI BANCO Serie	BEARINGS AND OIL SEALS KIT	KIT PALIERS JOINTS D'HUILE DE VILEBREQUIN Jeu				
KIT REVISIONE POMPA ACQUA	WATER PUMP REPAIR KIT	KIT RÉVISION POMPE À EAU				
KIT TAGLIANDO	SERVICE KIT	KIT COUPON				
MASSE CENTRIFUGHE PESO ORIGINALE	ROLLER WEIGHTS Standard weight	MASSELOTTE CENTRIFUGES POIDS D'ORIGINE				
MEMBRANA CARBURATORE TIPO ORIGINALE	CARBURETOR DIAPHRAGM OEM	MEMBRANE CARBURATEUR TYPE ORIGINAL				
MEMBRANA CARBURATORE ADATTABILE	CARBURETOR DIAPHRAGM Adaptable	MEMBRANE CARBURATEUR ADAPTABLE				
MOLLE CONTRASTO VARIATORE	REAR VARIATOR SPRING	RESSORTS CONTRASTE VARIATEUR				
MOLLA A GAS PER SELIA	SEAT GAS SPRING	RESSORT À GAZ POUR SELLE				
MOTORINO D'AVVIAMENTO	STARTER ENGINE	DÉMARREUR ÉLECTRIQUE		MA00007	MA00007	MA00007
PIATTELLO PORTATASSELI	VARIATOR SLIDERS	CURSEURS VARIATEUR				
POMPA BENZINA	FUEL PUMP	POMPE À ESSENCE				
PULEGGIA FISSA	FIXED SHEAVE	POULIE FIXE				
REGOLATORE DI TENSIONE	RECTIFIER	RÉGULATEUR DE TENSION		RE00019	RE00013	RE00013
RUOTA LIBERA Completa	STARTER CLUTCH SET	ROUE LIBRE Complète				
RUOTA LIBERA RL + flangia	STARTER CLUTCH + FLANGE	ROUE LIBRE RL + flasque		RL00025		
RUOTA LIBERA RL nuda	STARTER CLUTCH	ROUE LIBRE RL nue				
RUOTA LIBERA Ingranaggio	STARTER CLUTCH GEAR	ROUE LIBRE Engrenage		RL00024		
RUOTA LIBERA Flangia	STARTER CLUTCH FLANGE	ROUE LIBRE Flasque				
SERIE DISCHI FRIZIONE	CLUTCH PLATES KIT	JEU DISQUES EMBRAYAGE				
STATORE	STATOR	STATOR				
TASSELLI TRAINO	VARIATOR SLIDERS	CURSEURS VARIATEUR				
VARIATORE VARIOTOP TPR	VARIOTOP TPR	VARIOTOP TPR		9927830		

MALAGUTI	MALAGUTI	MALAGUTI	MALAGUTI	MALAGUTI	MALAGUTI	MALAGUTI	MALAGUTI	MALAGUTI	MALAGUTI	MALAGUTI	MALAGUTI
F18 WARRIOR	MADISON	MADISON 3	MADISON 3	MADISON K	MADISON R	MADISON R RESTYLING	MADISON R RESTYLING EU2	MADISON RS	MADISON S	MADISON S RESTYLING	MADISON T
00-02	99-01	06-09	06-09	02-02	01-02	02-02	03-04	04-04	99-01	02-02	99-01
150cc 4T LC	125cc 4T LC	125cc 4T LC	250cc 4T LC	400cc 4T LC	180cc 4T LC	125cc 4T LC	125cc 4T LC	250cc 4T LC	250cc 4T LC	200cc 4T LC	150cc 4T LC
Kymco	Minarelli YP	Piaggio	Piaggio	Morini	Piaggio	Minarelli YP	Minarelli YP	Piaggio M237M	Minarelli YP	Piaggio	Minarelli YP
	IM07045					IM07045	IM07045		IM07054		
		FZ00395	FZ00395		FZ00395			FZ00395	FZ00397	FZ00377	
9915220	9915380					9915380	9915380		9915800		9915380
9935660	9935700		9935470			9935700	9935700	9935470	9935710		9935700
	CT00730					CT00730					CT00730
		F007515	F007515		F007515			F007515		F007515	
	FZ00371	FZ00378	FZ00382			FZ00371	FZ00371	FZ00382	FZ00388	FZ00378	FZ00401
									9926850		
	9929380					9929380	9929380				9929380
	KK01010					KK01010	KK01010		KK01007		KK01010
	AA00805					AA00805	AA00805		AA00806		AA00805
	9915270			9922390		9915270	9915270		9918020		
							MC12001		MC12001		
	MC12100					MC12100	MC12101		MC12101		MC12100
	9929170					9929170	9929170		9929870		9929170
MA00007	MA00017					MA00017	MA00017		MA00010		MA00017
									PL04066		
									PL04075		
	RL00002					RL00002	RL00002	RL00021	RL00010		RL00002
			RL00023					RL00023	RL00011		
	9923550	9923600	9923650		9923650	9923550	9923550	9923650	9931790	9923650	9923550

MAXI SCOOTER

TOP
- performances -



MALAGUTI	MALAGUTI	MALAGUTI	MALAGUTI
PASSWORD	PASSWORD EU3	PHANTOM MAX	PHANTOM MAX
05-06	07-08	03-03	03-03
250cc 4T LC	250cc 4T LC	125cc 4T LC	200cc 4T LC
Minarelli YP	Minarelli YP	Minarelli YP	Piaggio

IT	EN	FR				
ALBERO A CAMME	CAM SHAFT	ARBRE À CAMES				
ALBERO MOTORE Sel 1/Sel 2	CRANKSHAFT Sel 1/Sel 2	VILEBREQUIN Sel 1/ Sel 2		IM07054	IM07054	IM07045
CAMPANA FRIZIONE	CLUTCH HOUSING	CLOCHE EMBRAYAGE		FZ00397	FZ00397	FZ00395
CINGHIA DI TRASMISSIONE Bando	TRANSMISSION BELT Bando	COURROIE DE TRANSMISSION Bando		9925600	9925600	9915380
CINGHIA DI TRASMISSIONE Mitsuboshi	TRANSMISSION BELT Mitsuboshi	COURROIE DE TRANSMISSION Mitsuboshi				9935700
CINGHIA DI TRASMISSIONE Altro	TRANSMISSION BELT Other	COURROIE DE TRANSMISSION Autres				
COLLETTORE ASPIRAZIONE	INLET MANIFOLD	COLLECTEUR ASPIRATION				CT00730
COLLETTORE ASPIRAZIONE SX	INLET MANIFOLD LEFT	COLLECTEUR ASPIRATION GAUCHE				
COLLETTORE ASPIRAZIONE DX	INLET MANIFOLD RIGHT	COLLECTEUR ASPIRATION DROITE				
FILTRO OLIO	OIL FILTER	FILTRE À HUILE				F007515
FRIZIONE	CLUTCH	EMBAYAGE		FZ00388	FZ00388	FZ00371
GRUPPO TERMICO Standard	CYLINDER KIT Ø standard	CYLINDRE COMPLET Standard		9926850	9926850	
GRUPPO TERMICO Maggiorato	CYLINDER KIT BIG BORE	CYLINDRE COMPLET Majoré				9929380
KIT CUSCINETTI PARAOLI DI BANCO Serie	BEARINGS AND OIL SEALS KIT	KIT PALIERS JOINTS D'HUILE DE VILEBREQUIN Jeu		KK01007	KK01007	KK01010
KIT REVISIONE POMPA ACQUA	WATER PUMP REPAIR KIT	KIT RÉVISION POMPE À EAU		AA00806	AA00806	AA00805
KIT TAGLIANDO	SERVICE KIT	KIT COUPON				
MASSE CENTRIFUGHE PESO ORIGINALE	ROLLER WEIGHTS Standard weight	MASSELOTTE CENTRIFUGES POIDS D'ORIGINE		9918060	9918060	9915270
MEMBRANA CARBURATORE TIPO ORIGINALE	CARBURETOR DIAPHRAGM OEM	MEMBRANE CARBURATEUR TYPE ORIGINAL				
MEMBRANA CARBURATORE ADATTABILE	CARBURETOR DIAPHRAGM Adaptable	MEMBRANE CARBURATEUR ADAPTABLE				MC12100
MOLLE CONTRASTO VARIATORE	REAR VARIATOR SPRING	RESSORTS CONTRASTE VARIATEUR		9929870	9929870	9929170
MOLLA A GAS PER SELIA	SEAT GAS SPRING	RESSORT À GAZ POUR SELLE				
MOTORINO D'AVVIAMENTO	STARTER ENGINE	DÉMARREUR ÉLECTRIQUE		MA00010	MA00010	MA00017
PIATTELLO PORTATASSELI	VARIATOR SLIDERS	CURSEURS VARIATEUR		PL04066		
POMPA BENZINA	FUEL PUMP	POMPE À ESSENCE				
PULEGGIA FISSA	FIXED SHEAVE	POULIE FIXE		PL04075	PL04075	
REGOLATORE DI TENSIONE	RECTIFIER	RÉGULATEUR DE TENSION				
RUOTA LIBERA Completa	STARTER CLUTCH SET	ROUE LIBRE Complète				
RUOTA LIBERA RL + flangia	STARTER CLUTCH + FLANGE	ROUE LIBRE RL + flasque		RL00010	RL00010	RL00002
RUOTA LIBERA RL nuda	STARTER CLUTCH	ROUE LIBRE RL nue				
RUOTA LIBERA Ingranaggio	STARTER CLUTCH GEAR	ROUE LIBRE Engrenage		RL00011	RL00011	
RUOTA LIBERA Flangia	STARTER CLUTCH FLANGE	ROUE LIBRE Flasque				
SERIE DISCHI FRIZIONE	CLUTCH PLATES KIT	JEU DISQUES EMBRAYAGE				
STATORE	STATOR	STATOR				
TASSELLI TRAINO	VARIATOR SLIDERS	CURSEURS VARIATEUR				
VARIATORE VARIOTOP TPR	VARIOTOP TPR	VARIOTOP TPR		9931790	9931790	9923550

MALAGUTI	MALAGUTI	MALAGUTI	MALAGUTI	MBK	MBK	MBK	MBK	MBK	MBK	MBK	MBK
PHANTOM MAX	SPIDER MAX GT	SPIDER MAX GT EU3	SPIDER MAX RS	CITYLINER EU3	D00D0	D00D0	FLAME F	FLAME R	FLAMET	KILIBRE	SKYCRUISER
04-04	04-05	06-06	08-08	08-10	00-00	01-02	00-00	96-99	95-99	03-06	07-07
250cc 4T LC	500cc 4T LC	500cc 4T LC	500cc 4T LC	125cc 4T-4V LC	125cc 4T LC	150cc 4T LC	125cc 4T AC	125cc 4T AC	125cc 4T AC	300cc 4T LC	125cc 4T-4V LC
Piaggio M361M	Piaggio	Piaggio M341M	Piaggio	Minarelli	Minarelli YP	Minarelli YP				Minarelli YP	Minarelli
				9927230							9927230
				IM07072	IM07045						IM07072
FZ00395	FZ00384	FZ00384	FZ00384							FZ00397	
	9927630	9927630	9927630	9925280	9915380	9915380	9931550	9931550	9931550	9925600	9925280
9935470					9935700	9935700					
					CT00730	CT00730			CT00730		
F007515	F007524	F007524	F007524	F007523							F007523
FZ00382	FZ00383	FZ00383	FZ00383		FZ00371	FZ00401				FZ00388	FZ00401
				9932700							9932700
				9925180	9929380	9929380					9925180
					KK01010	KK01010				KK01007	
				AA00823	AA00805	AA00805				AA00806	AA00823
	9922330				9915270					9918020	
										MC12001	
					MC12100	MC12100				MC12101	
	9926780	9926780	9926780	9926760	9929170	9929170					9926760
				MA00028	MA00017	MA00017				MA00010	MA00028
										PL04075	
						RE00020					
RL00021	RL00021	RL00021	RL00021	RL00034	RL00002	RL00002			RL00002	RL00010	RL00034
RL00023	RL00023	RL00023	RL00023	RL00035						RL00011	RL00035
					ST00002	ST00002					
9923650	9923250	9923250	9923250	9925020	9923550	9923550				9931790	9925020

MAXI SCOOTER

TOP
- performances -



MBK	MBK	MBK	MBK
SKYLINER	SKYLINER	SKYLINER	SKYLINER
98-00	01-02	00-00	01-02
125cc 4T LC	125cc 4T LC	150cc 4T LC	150cc 4T LC
Minarelli YP	Minarelli YP	Minarelli YP	Minarelli YP

IT	EN	FR				
ALBERO A CAMME	CAM SHAFT	ARBRE À CAMES				
ALBERO MOTORE Sel 1/Sel 2	CRANKSHAFT Sel 1/Sel 2	VILEBREQUIN Sél 1/ Sél 2		IM07045	IM07045	
CAMPANA FRIZIONE	CLUTCH HOUSING	CLOCHE EMBRAYAGE				
CINGHIA DI TRASMISSIONE Bando	TRANSMISSION BELT Bando	COURROIE DE TRANSMISSION Bando		9915380	9915380	9915380
CINGHIA DI TRASMISSIONE Mitsuboshi	TRANSMISSION BELT Mitsuboshi	COURROIE DE TRANSMISSION Mitsuboshi		9935700	9935700	9935700
CINGHIA DI TRASMISSIONE Altro	TRANSMISSION BELT Other	COURROIE DE TRANSMISSION Autres				
COLLETTORE ASPIRAZIONE	INLET MANIFOLD	COLLECTEUR ASPIRATION		CT00730	CT00730	CT00730
COLLETTORE ASPIRAZIONE SX	INLET MANIFOLD LEFT	COLLECTEUR ASPIRATION GAUCHE				
COLLETTORE ASPIRAZIONE DX	INLET MANIFOLD RIGHT	COLLECTEUR ASPIRATION DROITE				
FILTRO OLIO	OIL FILTER	FILTRE À HUILE				
FRIZIONE	CLUTCH	EMBRAYAGE		FZ00371	FZ00371	FZ00401
GRUPPO TERMICO Standard	CYLINDER KIT Ø standard	CYLINDRE COMPLET Standard				
GRUPPO TERMICO Maggiorato	CYLINDER KIT BIG BORE	CYLINDRE COMPLET Majoré		9929380	9929380	9929380
KIT CUSCINETTI PARAOLI DI BANCO Serie	BEARINGS AND OIL SEALS KIT	KIT PALIERS JOINTS D'HUILE DE VILEBREQUIN Jeu		KK01010	KK01010	KK01010
KIT REVISIONE POMPA ACQUA	WATER PUMP REPAIR KIT	KIT RÉVISION POMPE À EAU		AA00805	AA00805	AA00805
KIT TAGLIANDO	SERVICE KIT	KIT COUPON				
MASSE CENTRIFUGHE PESO ORIGINALE	ROLLER WEIGHTS Standard weight	MASSELOTTE CENTRIFUGES POIDS D'ORIGINE		9915270	9915270	
MEMBRANA CARBURATORE TIPO ORIGINALE	CARBURETOR DIAPHRAGM OEM	MEMBRANE CARBURATEUR TYPE ORIGINAL		MC12100	MC12100	
MEMBRANA CARBURATORE ADATTABILE	CARBURETOR DIAPHRAGM Adaptable	MEMBRANE CARBURATEUR ADAPTABLE				
MOLLE CONTRASTO VARIATORE	REAR VARIATOR SPRING	RESSORTS CONTRASTE VARIATEUR		9929170	9929170	9929170
MOLLA A GAS PER SELIA	SEAT GAS SPRING	RESSORT À GAZ POUR SELLE				
MOTORINO D'AVVIAMENTO	STARTER ENGINE	DÉMARREUR ÉLECTRIQUE		MA00017	MA00017	MA00017
PIATTELLO PORTATASSELI	VARIATOR SLIDERS	CURSEURS VARIATEUR				
POMPA BENZINA	FUEL PUMP	POMPE À ESSENCE				
PULEGGIA FISSA	FIXED SHEAVE	POULIE FIXE				
REGOLATORE DI TENSIONE	RECTIFIER	RÉGULATEUR DE TENSION		RE00020	RE00020	RE00020
RUOTA LIBERA Completa	STARTER CLUTCH SET	ROUE LIBRE Complète				
RUOTA LIBERA RL + flangia	STARTER CLUTCH + FLANGE	ROUE LIBRE RL + flasque		RL00002	RL00002	RL00002
RUOTA LIBERA RL nuda	STARTER CLUTCH	ROUE LIBRE RL nue				
RUOTA LIBERA Ingranaggio	STARTER CLUTCH GEAR	ROUE LIBRE Engrenage				
RUOTA LIBERA Flangia	STARTER CLUTCH FLANGE	ROUE LIBRE Flasque				
SERIE DISCHI FRIZIONE	CLUTCH PLATES KIT	JEU DISQUES EMBRAYAGE				
STATORE	STATOR	STATOR		ST00002	ST00002	ST00002
TASSELLI TRAINO	VARIATOR SLIDERS	CURSEURS VARIATEUR				
VARIATORE VARIOTOP TPR	VARIOTOP TPR	VARIOTOP TPR		9923550	9923550	9923550

MBK	MBK	MBK	MBK	MBK	MBK	MBK	PEUGEOT	PEUGEOT	PEUGEOT	PEUGEOT	PEUGEOT
SKYLINER	SKYLINER	SKYLINER ABS	SKYLINER E	SKYLINER E	THUNDER	THUNDER	CITYSTAR	CITYSTAR LC	CITYSTAR LC	GEOPOLIS	GEOPOLIS IE EU3
00-01	02-03	03-03	03-03	03-03	01-02	01-02	11-14	11-16	12-15	06-13	90-02
250cc 4T LC	250cc 4T LC	250cc 4T LC	125cc 4T LC	180cc 4T LC	125cc 4T LC	150cc 4T LC	125cc 4T-2V AC	125cc 4T-4V LC	200cc 4T-4V LC	125cc 4T-4V LC	250cc 4T-4V LC
Minarelli YP	Minarelli YP	Minarelli YP	Minarelli YP	Minarelli YP	Minarelli YP	Minarelli YP					Piaggio
IM07054	IM07054	IM07054	IM07045		IM07045						
FZ00397	FZ00397	FZ00397									
9915800	9915800	9915800	9915380		9915380	9915380					
9935710	9935710	9935710	9935700		9935700	9935700	9935350	9935350	9935390	9935380	
			CT00729	CT00729	CT00730	CT00730					
											F007515
FZ00388	FZ00388	FZ00388	FZ00371	FZ00401	FZ00371	FZ00401					
9926850	9926850	9926850									
			9929380		9929380	9929380					
KK01007	KK01007	KK01007	KK01010	KK01010	KK01010	KK01010					
AA00806	AA00806	AA00806	AA00805	AA00805	AA00805	AA00805					
9918060	9918060	9918060	9915270		9915270						
MC12001	MC12001	MC12001	MC12001	MC12001							
MC12101	MC12101	MC12101	MC12101	MC12101	MC12100	MC12100					
9929870	9929870	9929870	9929170		9929170	9929170					
MA00010	MA00010	MA00010	MA00017	MA00017	MA00017	MA00017					
PL04066	PL04066	PL04066									
PL04075	PL04075	PL04075									
			RE00030	RE00030							
RL00010	RL00010	RL00010	RL00032	RL00032	RL00002	RL00002					
RL00011	RL00011	RL00011									
			ST00002	ST00002	ST00002	ST00002					
9931790	9931790	9931790	9923550	9923550	9923550	9923550					9923650

MAXI SCOOTER

MAXI SCOOTER

TOP
- performances -



PEUGEOT	PEUGEOT	PEUGEOT	PEUGEOT
GEOPOLIS IE EU3	GEOPOLIS IE EU3	METROPOLIS	SATELIS
90-02	90-02	13-16	06-11
400cc 4T-4V LC	500cc 4T-4V LC	400cc 4T LC	125cc 4T-4V LC
Piaggio	Piaggio	Piaggio	

IT	EN	FR				
ALBERO A CAMME	CAM SHAFT	ARBRE À CAMES				
ALBERO MOTORE Sel 1/Sel 2	CRANKSHAFT Sel 1/Sel 2	VILEBREQUIN Sel 1/ Sel 2				
CAMPANA FRIZIONE	CLUTCH HOUSING	CLOCHE EMBRAYAGE		FZ00384	FZ00384	
CINGHIA DI TRASMISSIONE Bando	TRANSMISSION BELT Bando	COURROIE DE TRANSMISSION Bando		9927630	9927630	
CINGHIA DI TRASMISSIONE Mitsuboshi	TRANSMISSION BELT Mitsuboshi	COURROIE DE TRANSMISSION Mitsuboshi				9935400 9935350
CINGHIA DI TRASMISSIONE Altro	TRANSMISSION BELT Other	COURROIE DE TRANSMISSION Autres				
COLLETTORE ASPIRAZIONE	INLET MANIFOLD	COLLECTEUR ASPIRATION				
COLLETTORE ASPIRAZIONE SX	INLET MANIFOLD LEFT	COLLECTEUR ASPIRATION GAUCHE				
COLLETTORE ASPIRAZIONE DX	INLET MANIFOLD RIGHT	COLLECTEUR ASPIRATION DROITE				
FILTRO OLIO	OIL FILTER	FILTRE À HUILE		F007524	F007524	
FRIZIONE	CLUTCH	EMBRAYAGE		FZ00383	FZ00383	
GRUPPO TERMICO Standard	CYLINDER KIT Ø standard	CYLINDRE COMPLET Standard				
GRUPPO TERMICO Maggiorato	CYLINDER KIT BIG BORE	CYLINDRE COMPLET Majoré				
KIT CUSCINETTI PARAOLI DI BANCO Serie	BEARINGS AND OIL SEALS KIT	KIT PALIERS JOINTS D'HUILE DE VILEBREQUIN Jeu				
KIT REVISIONE POMPA ACQUA	WATER PUMP REPAIR KIT	KIT RÉVISION POMPE À EAU				
KIT TAGLIANDO	SERVICE KIT	KIT COUPON				
MASSE CENTRIFUGHE PESO ORIGINALE	ROLLER WEIGHTS Standard weight	MASSELOTTE CENTRIFUGES POIDS D'ORIGINE		9924530		
MEMBRANA CARBURATORE TIPO ORIGINALE	CARBURETOR DIAPHRAGM OEM	MEMBRANE CARBURATEUR TYPE ORIGINAL				
MEMBRANA CARBURATORE ADATTABILE	CARBURETOR DIAPHRAGM Adaptable	MEMBRANE CARBURATEUR ADAPTABLE				
MOLLE CONTRASTO VARIATORE	REAR VARIATOR SPRING	RESSORTS CONTRASTE VARIATEUR		9926780	9926780	
MOLLA A GAS PER SELIA	SEAT GAS SPRING	RESSORT À GAZ POUR SELLE				
MOTORINO D'AVVIAMENTO	STARTER ENGINE	DÉMARREUR ÉLECTRIQUE				
PIATTELLO PORTATASSELI	VARIATOR SLIDERS	CURSEURS VARIATEUR				
POMPA BENZINA	FUEL PUMP	POMPE À ESSENCE				
PULEGGIA FISSA	FIXED SHEAVE	POULIE FIXE				
REGOLATORE DI TENSIONE	RECTIFIER	RÉGULATEUR DE TENSION				
RUOTA LIBERA Completa	STARTER CLUTCH SET	ROUE LIBRE Complète				
RUOTA LIBERA RL + flangia	STARTER CLUTCH + FLANGE	ROUE LIBRE RL + flasque		RL00021	RL00021	
RUOTA LIBERA RL nuda	STARTER CLUTCH	ROUE LIBRE RL nue				
RUOTA LIBERA Ingranaggio	STARTER CLUTCH GEAR	ROUE LIBRE Engrenage		RL00023	RL00023	
RUOTA LIBERA Flangia	STARTER CLUTCH FLANGE	ROUE LIBRE Flasque				
SERIE DISCHI FRIZIONE	CLUTCH PLATES KIT	JEU DISQUES EMBRAYAGE				
STATORE	STATOR	STATOR				
TASSELLI TRAINO	VARIATOR SLIDERS	CURSEURS VARIATEUR				
VARIATORE VARIOTOP TPR	VARIOTOP TPR	VARIOTOP TPR		9923250	9923250	

PEUGEOT	PEUGEOT	PEUGEOT	PEUGEOT	PEUGEOT	PEUGEOT	PEUGEOT	PEUGEOT	PIAGGIO	PIAGGIO	PIAGGIO	PIAGGIO
SATELIS	SATELIS 2 PREMIUM	SATELIS COM-PRESSOR	SATELIS EU3	SATELIS EU3	SATELIS EU3	SATELIS RS IE	TWEET 125	BEVERLY	BEVERLY	BEVERLY	BEVERLY
13-16	12-14	06-06	90-02	07-12	90-02	06-11	-00	01-03	01-03	05-07	02-04
400cc 4T LC	125cc 4T-4V LC	125cc 4T-4V LC	250cc 4T LC	400cc 4T LC	500cc 4T LC	125cc 4T-4V LC	125cc 4T AC	125cc 4T LC	200cc 4T LC	250cc 4T LC	500cc 4T LC
Piaggio			Piaggio	Piaggio	Piaggio					Piaggio M285M	
								IM070701 IM070702			
				FZ00384	FZ00384			FZ00377	FZ00377	FZ00395	FZ00384
				9927630	9927630			9928540		9927640	9927630
9935400	9935350	9935390				9935350			9935450		
								CT00734		CT00735	
			F007515	F007524	F007524			F007515	F007515	F007515	F007524
				FZ00383	FZ00383			FZ00396		FZ00382	FZ00383
							9936000				
								AA00817	AA00817	AA00828	
										TG00101	
				9924530	9924530				9932790		9922330
								MC12002			
										MC12106	
				9926780	9926780						9926780
								MA00012		MA00016	MA00030
										PL04067	
								PL04060 PL04072			
								RE00011		RE00011	RE00004
				RL00021	RL00021						RL00021
				RL00023	RL00023			RL00022	RL00022	RL00023	RL00023
											ST00005
								AA00850			
			9923650	9923250	9923250			9923600	9923650	9923650	9923250

MAXI SCOOTER

TOP
- performances -



PIAGGIO	PIAGGIO	PIAGGIO	PIAGGIO
BEVERLY	BEVERLY EU3	BEVERLY 4T 4V IE EU3	BEVERLY 4T ST IE ABS
05-06	06-07	11-14	16-20
500cc 4T LC	400cc 4T LC	350cc 4T LC	350cc 4T LC
Piaggio	Piaggio M345M	Piaggio	Piaggio

IT	EN	FR				
ALBERO A CAMME	CAM SHAFT	ARBRE À CAMES				
ALBERO MOTORE Sel 1/Sel 2	CRANKSHAFT Sel 1/Sel 2	VILEBREQUIN Sel 1/ Sel 2				
CAMPANA FRIZIONE	CLUTCH HOUSING	CLOCHE EMBRAYAGE		FZ00384	FZ00384	
CINGHIA DI TRASMISSIONE Bando	TRANSMISSION BELT Bando	COURROIE DE TRANSMISSION Bando		9927630	9927630	
CINGHIA DI TRASMISSIONE Mitsuboshi	TRANSMISSION BELT Mitsuboshi	COURROIE DE TRANSMISSION Mitsuboshi				9935490
CINGHIA DI TRASMISSIONE Altro	TRANSMISSION BELT Other	COURROIE DE TRANSMISSION Autres				9935490
COLLETTORE ASPIRAZIONE	INLET MANIFOLD	COLLECTEUR ASPIRATION				
COLLETTORE ASPIRAZIONE SX	INLET MANIFOLD LEFT	COLLECTEUR ASPIRATION GAUCHE				
COLLETTORE ASPIRAZIONE DX	INLET MANIFOLD RIGHT	COLLECTEUR ASPIRATION DROITE				
FILTRO OLIO	OIL FILTER	FILTRE À HUILE		F007524	F007524	
FRIZIONE	CLUTCH	EMBAYAGE		FZ00383		
GRUPPO TERMICO Standard	CYLINDER KIT Ø standard	CYLINDRE COMPLET Standard				
GRUPPO TERMICO Maggiorato	CYLINDER KIT BIG BORE	CYLINDRE COMPLET Majoré				
KIT CUSCINETTI PARAOLI DI BANCO Serie	BEARINGS AND OIL SEALS KIT	KIT PALIERS JOINTS D'HUILE DE VILEBREQUIN Jeu				
KIT REVISIONE POMPA ACQUA	WATER PUMP REPAIR KIT	KIT RÉVISION POMPE À EAU			AA00824	AA00829
KIT TAGLIANDO	SERVICE KIT	KIT COUPON				
MASSE CENTRIFUGHE PESO ORIGINALE	ROLLER WEIGHTS Standard weight	MASSELOTES CENTRIFUGES POIDS D'ORIGINE		9935990	9924530	
MEMBRANA CARBURATORE TIPO ORIGINALE	CARBURETOR DIAPHRAGM OEM	MEMBRANE CARBURATEUR TYPE ORIGINAL				
MEMBRANA CARBURATORE ADATTABILE	CARBURETOR DIAPHRAGM Adaptable	MEMBRANE CARBURATEUR ADAPTABLE				
MOLLE CONTRASTO VARIATORE	REAR VARIATOR SPRING	RESSORTS CONTRASTE VARIATEUR		9926780	9926780	
MOLLA A GAS PER SELIA	SEAT GAS SPRING	RESSORT À GAZ POUR SELLE				
MOTORINO D'AVVIAMENTO	STARTER ENGINE	DÉMARREUR ÉLECTRIQUE		MA00030	MA00030	
PIATTELLO PORTATASSELI	VARIATOR SLIDERS	CURSEURS VARIATEUR				
POMPA BENZINA	FUEL PUMP	POMPE À ESSENCE				
PULEGGIA FISSA	FIXED SHEAVE	POULIE FIXE				
REGOLATORE DI TENSIONE	RECTIFIER	RÉGULATEUR DE TENSION		RE00004	RE00004	
RUOTA LIBERA Completa	STARTER CLUTCH SET	ROUE LIBRE Complète				
RUOTA LIBERA RL + flangia	STARTER CLUTCH + FLANGE	ROUE LIBRE RL + flasque		RL00021	RL00021	RL00021
RUOTA LIBERA RL nuda	STARTER CLUTCH	ROUE LIBRE RL nue				
RUOTA LIBERA Ingranaggio	STARTER CLUTCH GEAR	ROUE LIBRE Engrenage		RL00023	RL00023	RL00023
RUOTA LIBERA Flangia	STARTER CLUTCH FLANGE	ROUE LIBRE Flasque				
SERIE DISCHI FRIZIONE	CLUTCH PLATES KIT	JEU DISQUES EMBRAYAGE				9931020
STATORE	STATOR	STATOR		ST00005	ST00005	
TASSELLI TRAINO	VARIATOR SLIDERS	CURSEURS VARIATEUR				
VARIATORE VARIOTOP TPR	VARIOTOP TPR	VARIOTOP TPR		9923250	9923250	

PIAGGIO	PIAGGIO	PIAGGIO	PIAGGIO	PIAGGIO	PIAGGIO	PIAGGIO	PIAGGIO	PIAGGIO	PIAGGIO	PIAGGIO	PIAGGIO
BEVERLY CRUISER	BEVERLY CRUISER	BEVERLY EU3	BEVERLY EURO 3 MIC	BEVERLY EURO 3 MIC	BEVERLY EURO 3 SPORT	BEVERLY IE EU3	BEVERLY IE EU3	BEVERLY RST	BEVERLY RST	BEVERLY RST	BEVERLY RST 4T 4V IE EU3
07-09	07-12	07-08	07-07	07-07	07-08	06-08	06-08	04-05	05-07	04-05	10-15
250cc 4T LC	500cc 4T LC	125cc 4T LC	125cc 4T LC	250cc 4T LC	125cc 4T LC	250cc 4T LC	500cc 4T LC	125cc 4T LC	125cc 4T LC	250cc 4T LC	125cc 4T LC
	Piaggio Master						Piaggio M343M	M28400			
		IM070701 IM070702							IM070701 IM070702		
		FZ00395				FZ00395	FZ00384	FZ00395	FZ00395		
9927640		9928540	9928540	9927640	9928540	9927640	9927630	9928540	9928540	9927640	9928540
	9935500										
								CT00735	CT00735	CT00735	
F007515	F007524	F007515	F007515	F007515	F007515	F007515	F007524	F007515	F007515	F007515	F007515
	FZ00383	FZ00396					FZ00383	FZ00396	FZ00396		
AA00828	AA00824	AA00826	AA00826	AA00828	AA00826	AA00828	AA00824	AA00817	AA00826		AA00826
TG00101	TG00112			TG00101		TG00101				TG00101	
9931880	9935990					9931880	9935990				
		MC12106	MC12106		MC12106				MC12106		
	9926780						9926780				
MA00016	MA00030	MA00012	MA00012		MA00012	MA00016	MA00030	MA00012	MA00012	MA00016	
PL04067		PL04067	PL04067	PL04067	PL04067	PL04067		PL04067	PL04067	PL04067	PL04067
		PL04072	PL04072		PL04072			PL04060 PL04072	PL04072		
RE00004	RE00004	RE00011	RE00011		RE00011	RE00004	RE00004	RE00011	RE00011	RE00011	
				RL00041		RL00041	RL00021			RL00021	RL00041
RL00023	RL00023	RL00022	RL00022	RL00023	RL00022	RL00023	RL00023	RL00022	RL00022	RL00023	
ST00023				ST00023		ST00023	ST00005				
		AA00850	AA00850		AA00850			AA00850	AA00850		AA00850
	9923250	9923600	9923600		9923600	9923650	9923250	9923600	9923600	9923650	9923600

MAXI SCOOTER

MAXI SCOOTER

TOP
- performances -



PIAGGIO	PIAGGIO	PIAGGIO	PIAGGIO
BEVERLY RST 4T 4V IE EU3	BEVERLY SPORT	BEVERLY TOURER EU3	BEVERLY TOURER EU3
10-16	06-08	07-10	07-09
300cc 4T LC	250cc 4T LC	125cc 4T LC	250cc 4T LC

IT	EN	FR				
ALBERO A CAMME	CAM SHAFT	ARBRE À CAMES				
ALBERO MOTORE Sel 1/Sel 2	CRANKSHAFT Sel 1/Sel 2	VILEBREQUIN Sél 1/ Sél 2				IM070701 IM070702
CAMPANA FRIZIONE	CLUTCH HOUSING	CLOCHE EMBRAYAGE				FZ00395 FZ00395
CINGHIA DI TRASMISSIONE Bando	TRANSMISSION BELT Bando	COURROIE DE TRANSMISSION Bando		9927640	9927640	9928540 9927640
CINGHIA DI TRASMISSIONE Mitsuboshi	TRANSMISSION BELT Mitsuboshi	COURROIE DE TRANSMISSION Mitsuboshi				
CINGHIA DI TRASMISSIONE Altro	TRANSMISSION BELT Other	COURROIE DE TRANSMISSION Autres				
COLLETTORE ASPIRAZIONE	INLET MANIFOLD	COLLECTEUR ASPIRATION				
COLLETTORE ASPIRAZIONE SX	INLET MANIFOLD LEFT	COLLECTEUR ASPIRATION GAUCHE				
COLLETTORE ASPIRAZIONE DX	INLET MANIFOLD RIGHT	COLLECTEUR ASPIRATION DROITE				
FILTRO OLIO	OIL FILTER	FILTRE À HUILE		F007515	F007515	F007515 F007515
FRIZIONE	CLUTCH	EMBAYAGE				FZ00396
GRUPPO TERMICO Standard	CYLINDER KIT Ø standard	CYLINDRE COMPLET Standard				
GRUPPO TERMICO Maggiorato	CYLINDER KIT BIG BORE	CYLINDRE COMPLET Majoré				
KIT CUSCINETTI PARAOLI DI BANCO Serie	BEARINGS AND OIL SEALS KIT	KIT PALIERS JOINTS D'HUILE DE VILEBREQUIN Jeu				
KIT REVISIONE POMPA ACQUA	WATER PUMP REPAIR KIT	KIT RÉVISION POMPE À EAU		AA00828	AA00828	AA00826 AA00828
KIT TAGLIANDO	SERVICE KIT	KIT COUPON		TG00102	TG00101	TG00101
MASSE CENTRIFUGHE PESO ORIGINALE	ROLLER WEIGHTS Standard weight	MASSELOTES CENTRIFUGES POIDS D'ORIGINE		9931880	9931880	9931880
MEMBRANA CARBURATORE TIPO ORIGINALE	CARBURETOR DIAPHRAGM OEM	MEMBRANE CARBURATEUR TYPE ORIGINAL				
MEMBRANA CARBURATORE ADATTABILE	CARBURETOR DIAPHRAGM Adaptable	MEMBRANE CARBURATEUR ADAPTABLE				MC12106
MOLLE CONTRASTO VARIATORE	REAR VARIATOR SPRING	RESSORTS CONTRASTE VARIATEUR				
MOLLA A GAS PER SELIA	SEAT GAS SPRING	RESSORT À GAZ POUR SELLE				
MOTORINO D'AVVIAMENTO	STARTER ENGINE	DÉMARREUR ÉLECTRIQUE		MA00016		MA00012 MA00016
PIATTELLO PORTATASSELI	VARIATOR SLIDERS	CURSEURS VARIATEUR		PL04067	PL04067	PL04067 PL04067
POMPA BENZINA	FUEL PUMP	POMPE À ESSENCE				
PULEGGIA FISSA	FIXED SHEAVE	POULIE FIXE				PL04072
REGOLATORE DI TENSIONE	RECTIFIER	RÉGULATEUR DE TENSION			RE00004	RE00011 RE00004
RUOTA LIBERA Completa	STARTER CLUTCH SET	ROUE LIBRE Complète				
RUOTA LIBERA RL + flangia	STARTER CLUTCH + FLANGE	ROUE LIBRE RL + flasque		RL00021	RL00041	RL00041
RUOTA LIBERA RL nuda	STARTER CLUTCH	ROUE LIBRE RL nue				
RUOTA LIBERA Ingranaggio	STARTER CLUTCH GEAR	ROUE LIBRE Engrenage		RL00023	RL00023	RL00022 RL00023
RUOTA LIBERA Flangia	STARTER CLUTCH FLANGE	ROUE LIBRE Flasque				
SERIE DISCHI FRIZIONE	CLUTCH PLATES KIT	JEU DISQUES EMBRAYAGE				
STATORE	STATOR	STATOR			ST00023	ST00023
TASSELLI TRAINO	VARIATOR SLIDERS	CURSEURS VARIATEUR				AA00850
VARIATORE VARIOTOP TPR	VARIOTOP TPR	VARIOTOP TPR				9923600

PIAGGIO	PIAGGIO	PIAGGIO	PIAGGIO	PIAGGIO	PIAGGIO	PIAGGIO	PIAGGIO	PIAGGIO	PIAGGIO	PIAGGIO	PIAGGIO
BEVERLY TOURER EU3	BEVERLY TOURER EU3	CARNABY	CARNABY	CARNABY	CARNABY CRUISER	FLY	FLY	FLY 4T 3V IE E3 DT	FLY 4T 3V IE EURO3 LEM	FLY EU3	FLY EU3
09-10	08-10	07-10	07-08	08-09	09-12	05-07	05-07	13-15	12-13	07-07	08-11
300cc 4T LC	400cc 4T LC	125cc 4T LC	200cc 4T LC	250cc 4T LC	300cc 4T LC	125cc 4T AC	150cc 4T AC	125cc 4T-3V LC	125cc 4T-3V LC	125cc 4T AC	125cc 4T AC
Piaggio M28MM	Piaggio M349M	Leader M28FM	Leader M601M		Piaggio M604M	Leader M422M	Leader M422M				
		IM070701 IM070702				IM070701 IM070702	IM070701 IM070702			IM070701 IM070702	IM070701 IM070702
FZ00395	FZ00384	FZ00395	FZ00395		FZ00395	FZ00395	FZ00395				
9927640	9927630	9928540		9927640	9927640	9927650	9927650			9927650	9927650
			9935450								
						CT00736	CT00736			CT00736	CT00736
F007515	F007524	F007515	F007515	F007515	F007515	F007515	F007515			F007515	F007515
		FZ00396	FZ00378	FZ00382		FZ00378	FZ00378			FZ00418	
AA00828	AA00824	AA00817	AA00826	AA00828	AA00828						
TG00102				TG00101	TG00102						
9931880			9932790	9931880	9931880						
		MC12106	MC12106			MC12107	MC12107			MC12107	MC12107
	9926780										
MA00016	MA00030	MA00012	MA00012	MA00016	MA00016	MA00012	MA00012			MA00012	MA00012
PL04067		PL04067	PL04067	PL04067	PL04067	PL04067	PL04067	PL04067	PL04067	PL04067	
		PL04072				PL04072	PL04072			PL04072	PL04072
RE00004	RE00004	RE00011	RE00011	RE00004	RE00004	RE00011	RE00011			RE00011	RE00011
RL00021	RL00021			RL00041	RL00021						
RL00023	RL00023	RL00022	RL00022	RL00023		RL00022	RL00022			RL00022	RL00022
ST00023				ST00023	ST00023						
		AA00850	AA00850			AA00850	AA00850			AA00850	AA00850
9923650	9923250	9923600	9923650	9923650	9923650	9923600	9923600				

MAXI SCOOTER

TOP
- performances -



PIAGGIO PIAGGIO PIAGGIO PIAGGIO

FLY EU3	HEXAGON	HEXAGON	HEXAGON GT
08-11	94-97	94-97	98-00
150cc 4T AC	125cc 2T LC	150cc 2T LC	250cc 4T LC
			Motore Honda

IT	EN	FR					
ALBERO A CAMME	CAM SHAFT	ARBRE À CAMES					
ALBERO MOTORE Sel 1/Sel 2	CRANKSHAFT Sel 1/Sel 2	VILEBREQUIN Sél 1/ Sél 2		IM070701 IM070702			
CAMPANA FRIZIONE	CLUTCH HOUSING	CLOCHE EMBRAYAGE					
CINGHIA DI TRASMISSIONE Bando	TRANSMISSION BELT Bando	COURROIE DE TRANSMISSION Bando		9927650	9915360	9915350	9915410
CINGHIA DI TRASMISSIONE Mitsuboshi	TRANSMISSION BELT Mitsuboshi	COURROIE DE TRANSMISSION Mitsuboshi			9935680	9935670	
CINGHIA DI TRASMISSIONE Altro	TRANSMISSION BELT Other	COURROIE DE TRANSMISSION Autres					
COLLETTORE ASPIRAZIONE	INLET MANIFOLD	COLLECTEUR ASPIRATION		CT00736	CT00728	CT00728	
COLLETTORE ASPIRAZIONE SX	INLET MANIFOLD LEFT	COLLECTEUR ASPIRATION GAUCHE					
COLLETTORE ASPIRAZIONE DX	INLET MANIFOLD RIGHT	COLLECTEUR ASPIRATION DROITE					
FILTRO OLIO	OIL FILTER	FILTRE À HUILE		F007515			
FRIZIONE	CLUTCH	EMBAYAGE		FZ00418			
GRUPPO TERMICO Standard	CYLINDER KIT Ø standard	CYLINDRE COMPLET Standard					
GRUPPO TERMICO Maggiorato	CYLINDER KIT BIG BORE	CYLINDRE COMPLET Majoré					
KIT CUSCINETTI PARAOLI DI BANCO Serie	BEARINGS AND OIL SEALS KIT	KIT PALIERS JOINTS D'HUILE DE VILEBREQUIN Jeu					
KIT REVISIONE POMPA ACQUA	WATER PUMP REPAIR KIT	KIT RÉVISION POMPE À EAU					
KIT TAGLIANDO	SERVICE KIT	KIT COUPON					
MASSE CENTRIFUGHE PESO ORIGINALE	ROLLER WEIGHTS Standard weight	MASSELOTTE CENTRIFUGES POIDS D'ORIGINE					
MEMBRANA CARBURATORE TIPO ORIGINALE	CARBURETOR DIAPHRAGM OEM	MEMBRANE CARBURATEUR TYPE ORIGINAL					
MEMBRANA CARBURATORE ADATTABILE	CARBURETOR DIAPHRAGM Adaptable	MEMBRANE CARBURATEUR ADAPTABLE		MC12107			
MOLLE CONTRASTO VARIATORE	REAR VARIATOR SPRING	RESSORTS CONTRASTE VARIATEUR					
MOLLA A GAS PER SELIA	SEAT GAS SPRING	RESSORT À GAZ POUR SELLE					
MOTORINO D'AVVIAMENTO	STARTER ENGINE	DÉMARREUR ÉLECTRIQUE		MA00012			
PIATTELLO PORTATASSELI	VARIATOR SLIDERS	CURSEURS VARIATEUR		PL04067			
POMPA BENZINA	FUEL PUMP	POMPE À ESSENCE					
PULEGGIA FISSA	FIXED SHEAVE	POULIE FIXE		PL04072			
REGOLATORE DI TENSIONE	RECTIFIER	RÉGULATEUR DE TENSION		RE00011			
RUOTA LIBERA Completa	STARTER CLUTCH SET	ROUE LIBRE Complète					
RUOTA LIBERA RL + flangia	STARTER CLUTCH + FLANGE	ROUE LIBRE RL + flasque					
RUOTA LIBERA RL nuda	STARTER CLUTCH	ROUE LIBRE RL nue					
RUOTA LIBERA Ingranaggio	STARTER CLUTCH GEAR	ROUE LIBRE Engrenage		RL00022			
RUOTA LIBERA Flangia	STARTER CLUTCH FLANGE	ROUE LIBRE Flasque					
SERIE DISCHI FRIZIONE	CLUTCH PLATES KIT	JEU DISQUES EMBRAYAGE					
STATORE	STATOR	STATOR					
TASSELLI TRAINO	VARIATOR SLIDERS	CURSEURS VARIATEUR		AA00850			
VARIATORE VARIOTOP TPR	VARIOTOP TPR	VARIOTOP TPR					

PIAGGIO	PIAGGIO	PIAGGIO	PIAGGIO	PIAGGIO	PIAGGIO	PIAGGIO	PIAGGIO	PIAGGIO	PIAGGIO	PIAGGIO	PIAGGIO
HEXAGON GTX	HEXAGON GTX	HEXAGON LX	HEXAGON LX4	HEXAGON LXT180	LIBERTY	LIBERTY	LIBERTY	LIBERTY	LIBERTY 4T	LIBERTY 4T 2V EURO3	LIBERTY 4T 3V LEM
00-00	00-00	98-99	98-99	98-99	98-00	01-02	01-02	06-06	06-07	09-12	13-14
125cc 4T LC	180cc 4T LC	125cc 2T LC	125cc 4T AC	180cc 2T LC	125cc 4T AC	125cc 4T AC	150cc 4T AC	200cc 4T AC	125cc 4T AC	125cc 4T AC	150cc 4T-3V LC
						Leader	Leader				
IM070701 IM070702						IM070701 IM070702	IM070701 IM070702		IM070701 IM070702		
FZ00395	FZ00377				FZ00395	FZ00395	FZ00395	FZ00395			
9927650		9915360		9915340		9927650	9927650		9927650	9927650	
	9935920	9935680	9935430	9935780	9935430			9935920			
CT00734				CT00728	CT00739	CT00740		CT00736	CT00736	CT00736	
F007515	F007515		F007514		F007514	F007515	F007515	F007515	F007515	F007515	F007515
FZ00396	FZ00378				FZ00396	FZ00396	FZ00378	FZ00378			
AA00817	AA00817										
									TG00100		
	9932790			9922670				9932790			
MC12002	MC12002				MC12002	MC12002	MC12002				
								MC12107	MC12107	MC12107	
MA00012	MA00012					MA00012		MA00012	MA00012	MA00012	
PL04067								PL04067	PL04067	PL04067	PL04067
PL04072					PL04072	PL04072	PL04072		PL04072	PL04072	
RE00011			RE00012		RE00012	RE00011		RE00011	RE00011		
RL00022	RL00022				RL00022	RL00022	RL00022	RL00022	RL00022	RL00022	RL00022
AA00850			AA00850		AA00850	AA00850		AA00850	AA00850	AA00850	
9923600					9923600	9923600	9923600	9923650			

MAXI SCOOTER

TOP
- performances -



PIAGGIO	PIAGGIO	PIAGGIO	PIAGGIO
LIBERTY 4T EU3	LIBERTY 4T EU3	LIBERTY 4T EU3	LIBERTY 4T EU3 DELIVERY - SINGLE
06-08	08-08	06-08	07-15
125cc 4T AC	150cc 4T AC	200cc 4T AC	125cc 4T AC

IT	EN	FR				
ALBERO A CAMME	CAM SHAFT	ARBRE À CAMES				
ALBERO MOTORE Sel 1/Sel 2	CRANKSHAFT Sel 1/Sel 2	VILEBREQUIN Sel 1/ Sel 2		IM070701 IM070702	IM070701 IM070702	
CAMPANA FRIZIONE	CLUTCH HOUSING	CLOCHE EMBRAYAGE				
CINGHIA DI TRASMISSIONE Bando	TRANSMISSION BELT Bando	COURROIE DE TRANSMISSION Bando		9927650	9927650	
CINGHIA DI TRASMISSIONE Mitsuboshi	TRANSMISSION BELT Mitsuboshi	COURROIE DE TRANSMISSION Mitsuboshi				9935920
CINGHIA DI TRASMISSIONE Altro	TRANSMISSION BELT Other	COURROIE DE TRANSMISSION Autres				
COLLETTORE ASPIRAZIONE	INLET MANIFOLD	COLLECTEUR ASPIRATION				
COLLETTORE ASPIRAZIONE SX	INLET MANIFOLD LEFT	COLLECTEUR ASPIRATION GAUCHE				
COLLETTORE ASPIRAZIONE DX	INLET MANIFOLD RIGHT	COLLECTEUR ASPIRATION DROITE				
FILTRO OLIO	OIL FILTER	FILTRE À HUILE		F007515		F007515
FRIZIONE	CLUTCH	EMBAYAGE		FZ00418		
GRUPPO TERMICO Standard	CYLINDER KIT Ø standard	CYLINDRE COMPLET Standard				
GRUPPO TERMICO Maggiorato	CYLINDER KIT BIG BORE	CYLINDRE COMPLET Majoré				
KIT CUSCINETTI PARAOLI DI BANCO Serie	BEARINGS AND OIL SEALS KIT	KIT PALIERS JOINTS D'HUILE DE VILEBREQUIN Jeu				
KIT REVISIONE POMPA ACQUA	WATER PUMP REPAIR KIT	KIT RÉVISION POMPE À EAU				
KIT TAGLIANDO	SERVICE KIT	KIT COUPON		TG00100	TG00100	
MASSE CENTRIFUGHE PESO ORIGINALE	ROLLER WEIGHTS Standard weight	MASSELOTTE CENTRIFUGES POIDS D'ORIGINE				9932790
MEMBRANA CARBURATORE TIPO ORIGINALE	CARBURETOR DIAPHRAGM OEM	MEMBRANE CARBURATEUR TYPE ORIGINAL				
MEMBRANA CARBURATORE ADATTABILE	CARBURETOR DIAPHRAGM Adaptable	MEMBRANE CARBURATEUR ADAPTABLE		MC12107	MC12107	MC12107 MC12107
MOLLE CONTRASTO VARIATORE	REAR VARIATOR SPRING	RESSORTS CONTRASTE VARIATEUR				
MOLLA A GAS PER SELIA	SEAT GAS SPRING	RESSORT À GAZ POUR SELLE				
MOTORINO D'AVVIAMENTO	STARTER ENGINE	DÉMARREUR ÉLECTRIQUE		MA00012	MA00012	MA00012
PIATTELLO PORTATASSELI	VARIATOR SLIDERS	CURSEURS VARIATEUR		PL04067	PL04067	PL04067 PL04067
POMPA BENZINA	FUEL PUMP	POMPE À ESSENCE				
PULEGGIA FISSA	FIXED SHEAVE	POULIE FIXE		PL04072	PL04072	
REGOLATORE DI TENSIONE	RECTIFIER	RÉGULATEUR DE TENSION		RE00011	RE00011	RE00011
RUOTA LIBERA Completa	STARTER CLUTCH SET	ROUE LIBRE Complète				
RUOTA LIBERA RL + flangia	STARTER CLUTCH + FLANGE	ROUE LIBRE RL + flasque				
RUOTA LIBERA RL nuda	STARTER CLUTCH	ROUE LIBRE RL nue				
RUOTA LIBERA Ingranaggio	STARTER CLUTCH GEAR	ROUE LIBRE Engrenage		RL00022	RL00022	RL00022
RUOTA LIBERA Flangia	STARTER CLUTCH FLANGE	ROUE LIBRE Flasque				
SERIE DISCHI FRIZIONE	CLUTCH PLATES KIT	JEU DISQUES EMBRAYAGE				
STATORE	STATOR	STATOR				
TASSELLI TRAINO	VARIATOR SLIDERS	CURSEURS VARIATEUR		AA00850	AA00850	AA00850 AA00850
VARIATORE VARIOTOP TPR	VARIOTOP TPR	VARIOTOP TPR				

PIAGGIO	PIAGGIO	PIAGGIO	PIAGGIO	PIAGGIO	PIAGGIO	PIAGGIO	PIAGGIO	PIAGGIO	PIAGGIO	PIAGGIO	PIAGGIO
LIBERTY 4T EU3 DELIVERY - TNT	LIBERTY 4T SPORT EU3	LIBERTY 4T SPORT EU3	LIBERTY 4T SPORT EU3	LIBERTY IGET 4T 3V IE	LIBERTY MOC 4T	LIBERTY RST	LIBERTY RST	LIBERTY RST PTT	LIBERTY SPORT	LIBERTY SPORT	MP3
08-15	06-08	08-08	06-07	15-16	09-13	04-05	04-04	05-11	06-06	06-06	06-08
125cc 4T AC	125cc 4T AC	150cc 4T AC	200cc 4T AC	150cc 4T-3V LC	150cc 4T AC	125cc 4T AC	200cc 4T AC	125cc 4T AC	125cc 4T AC	200cc 4T AC	125cc 4T LC
			Leader								Piaggio M631M
IM070701 IM070702	IM070701 IM070702	IM070701 IM070702			IM070701 IM070702			IM070701 IM070702	IM070701 IM070702		IM070701 IM070702
			FZ00395								FZ00395
9927650	9927650	9927650			9927650	9927650		9927650	9927650		9927650
			9935920				9935920			9935920	
CT00736					CT00736	CT00736	CT00736		CT00736	CT00736	
F007515	F007515	F007515	F007515		F007515	F007515	F007515	F007515	F007515	F007515	F007515
					FZ00418						FZ00396
											AA00826
TG00100	TG00100	TG00100							TG00100		TG00111
			9932790				9932790			9932790	
MC12107	MC12107	MC12107	MC12107		MC12107			MC12107	MC12107	MC12107	MC12106
MA00012	MA00012	MA00012	MA00012		MA00012	MA00012	MA00012		MA00012	MA00012	MA00012
PL04067	PL04067	PL04067	PL04067	PL04067	PL04067	PL04067	PL04067	PL04067	PL04067	PL04067	PL04067
PL04072	PL04072	PL04072			PL04072	PL04072		PL04072	PL04072		PL04072
RE00011	RE00011	RE00011	RE00011		RE00011	RE00011	RE00011		RE00011	RE00011	RE00011
RL00022	RL00022	RL00022	RL00022		RL00022	RL00022	RL00022	RL00022	RL00022	RL00022	RL00022
AA00850	AA00850	AA00850	AA00850		AA00850	AA00850	AA00850	AA00850	AA00850	AA00850	AA00850
			9923650			9923600	9923600				9923600

MAXI SCOOTER

MAXI SCOOTER

TOP
- performances -



PIAGGIO	PIAGGIO	PIAGGIO	PIAGGIO
MP3	MP3	MP3 4T 4V IE ERL IBRIDO	MP3 4T 4V IE LT IBRIDO
06-08	07-08	10-13	10-11
250cc 4T LC	400cc 4T LC	300cc 4T-4V LC	300cc 4T LC
Quasar M472M	Piaggio M474M		

IT	EN	FR				
ALBERO A CAMME	CAM SHAFT	ARBRE À CAMES				
ALBERO MOTORE Sel 1/Sel 2	CRANKSHAFT Sel 1/Sel 2	VILEBREQUIN Sel 1/ Sel 2				
CAMPANA FRIZIONE	CLUTCH HOUSING	CLOCHE EMBRAYAGE		FZ00395	FZ00384	FZ00395
CINGHIA DI TRASMISSIONE Bando	TRANSMISSION BELT Bando	COURROIE DE TRANSMISSION Bando			9927630	
CINGHIA DI TRASMISSIONE Mitsuboshi	TRANSMISSION BELT Mitsuboshi	COURROIE DE TRANSMISSION Mitsuboshi		9935470		9935470
CINGHIA DI TRASMISSIONE Altro	TRANSMISSION BELT Other	COURROIE DE TRANSMISSION Autres				
COLLETTORE ASPIRAZIONE	INLET MANIFOLD	COLLECTEUR ASPIRATION				
COLLETTORE ASPIRAZIONE SX	INLET MANIFOLD LEFT	COLLECTEUR ASPIRATION GAUCHE				
COLLETTORE ASPIRAZIONE DX	INLET MANIFOLD RIGHT	COLLECTEUR ASPIRATION DROITE				
FILTRO OLIO	OIL FILTER	FILTRE À HUILE		F007515	F007524	F007515
FRIZIONE	CLUTCH	EMBAYAGE		FZ00382		FZ00382
GRUPPO TERMICO Standard	CYLINDER KIT Ø standard	CYLINDRE COMPLET Standard				
GRUPPO TERMICO Maggiorato	CYLINDER KIT BIG BORE	CYLINDRE COMPLET Majoré				
KIT CUSCINETTI PARAOLI DI BANCO Serie	BEARINGS AND OIL SEALS KIT	KIT PALIERS JOINTS D'HUILE DE VILEBREQUIN Jeu				
KIT REVISIONE POMPA ACQUA	WATER PUMP REPAIR KIT	KIT RÉVISION POMPE À EAU		AA00828	AA00824	AA00828
KIT TAGLIANDO	SERVICE KIT	KIT COUPON				
MASSE CENTRIFUGHE PESO ORIGINALE	ROLLER WEIGHTS Standard weight	MASSELOTTE CENTRIFUGES POIDS D'ORIGINE				9931880
MEMBRANA CARBURATORE TIPO ORIGINALE	CARBURETOR DIAPHRAGM OEM	MEMBRANE CARBURATEUR TYPE ORIGINAL				
MEMBRANA CARBURATORE ADATTABILE	CARBURETOR DIAPHRAGM Adaptable	MEMBRANE CARBURATEUR ADAPTABLE				
MOLLE CONTRASTO VARIATORE	REAR VARIATOR SPRING	RESSORTS CONTRASTE VARIATEUR			9926780	
MOLLA A GAS PER SELIA	SEAT GAS SPRING	RESSORT À GAZ POUR SELLE				
MOTORINO D'AVVIAMENTO	STARTER ENGINE	DÉMARREUR ÉLECTRIQUE		MA00016	MA00030	
PIATTELLO PORTATASSELI	VARIATOR SLIDERS	CURSEURS VARIATEUR		PL04067		PL04067
POMPA BENZINA	FUEL PUMP	POMPE À ESSENCE				
PULEGGIA FISSA	FIXED SHEAVE	POULIE FIXE				
REGOLATORE DI TENSIONE	RECTIFIER	RÉGULATEUR DE TENSION		RE00004	RE00004	
RUOTA LIBERA Completa	STARTER CLUTCH SET	ROUE LIBRE Complète				
RUOTA LIBERA RL + flangia	STARTER CLUTCH + FLANGE	ROUE LIBRE RL + flasque		RL00041	RL00021	RL00021
RUOTA LIBERA RL nuda	STARTER CLUTCH	ROUE LIBRE RL nue				
RUOTA LIBERA Ingranaggio	STARTER CLUTCH GEAR	ROUE LIBRE Engrenage		RL00023	RL00023	RL00023
RUOTA LIBERA Flangia	STARTER CLUTCH FLANGE	ROUE LIBRE Flasque				
SERIE DISCHI FRIZIONE	CLUTCH PLATES KIT	JEU DISQUES EMBRAYAGE				
STATORE	STATOR	STATOR		ST00023		
TASSELLI TRAINO	VARIATOR SLIDERS	CURSEURS VARIATEUR				
VARIATORE VARIOTOP TPR	VARIOTOP TPR	VARIOTOP TPR		9923650	9923250	9923650

PIAGGIO	PIAGGIO	PIAGGIO	PIAGGIO	PIAGGIO	PIAGGIO	PIAGGIO	PIAGGIO	PIAGGIO	PIAGGIO	PIAGGIO	PIAGGIO
MP3 IBRIDO	MP3 IE	MP3 IE LT	MP3 IE LT TOURING	MP3 IE LT TOURING	MP3 IE LT/SPORT	MP3 IE LT/SPORT	MP3 IE MIC	MP3 IE MIC	MP3 IE TOURING	MP3 IE TOURING	MP3 LT
09-10	08-09	10-11	11-13	11-11	11-14	08-10	10-10	11-11	11-12	11-12	08-09
125cc 4T LC	125cc 4T LC	300cc 4T LC	300cc 4T LC	400cc 4T LC	300cc 4T LC	400cc 4T LC	300cc 4T LC	300cc 4T LC	125cc 4T LC	300cc 4T LC	250cc 4T LC
FZ00395	FZ00395	FZ00395	FZ00395	FZ00384	FZ00395	FZ00384	FZ00395	FZ00395	FZ00395	FZ00395	FZ00395
9927650	9927650			9927630		9927630			9927650		
		9935470	9935470		9935470		9935470	9935470		9935470	9935470
F007515	F007515	F007515	F007515	F007524	F007515	F007524	F007515	F007515	F007515	F007515	F007515
FZ00396	FZ00396	FZ00382	FZ00382		FZ00382		FZ00382	FZ00382		FZ00382	FZ00382
		AA00828	AA00828	AA00824	AA00828	AA00824	AA00828	AA00828		AA00828	AA00828
TG00111	TG00111								TG00111		
		9931880	9931880		9931880		9931880	9931880		9931880	
				9926780		9926780					
				MA00030		MA00030					MA00016
PL04067	PL04067	PL04067	PL04067		PL04067		PL04067	PL04067	PL04067	PL04067	PL04067
RE00004	RE00004			RE00004		RE00004					RE00004
RL00041	RL00041	RL00021	RL00021	RL00021	RL00021	RL00021	RL00021	RL00021	RL00041	RL00021	RL00041
RL00023	RL00023	RL00023	RL00023	RL00023	RL00023	RL00023	RL00023	RL00023	RL00023	RL00023	RL00023
ST00023	ST00023										ST00023
AA00850	AA00850								AA00850		
9923600	9923600	9923650	9923650	9923250	9923650	9923250	9923650	9923650	9923600	9923650	9923650

MAXI SCOOTER

MAXI SCOOTER

TOP
- performances -



PIAGGIO	PIAGGIO	PIAGGIO	PIAGGIO
MP3 LT BUSINESS - SPORT ABS - ENJOY	MP3 LT BUSINESS ABS	MP3 LT E4 SPORT/BUSINESS	MP3 LT SPORT/BUSINESS
14-15	14-16	16-17	11-13
300cc 4T LC	500cc 4T LC	500cc 4T LC	500cc 4T LC

IT	EN	FR				
ALBERO A CAMME	CAM SHAFT	ARBRE À CAMES				
ALBERO MOTORE Sel 1/Sel 2	CRANKSHAFT Sel 1/Sel 2	VILEBREQUIN Sél 1/ Sél 2				
CAMPANA FRIZIONE	CLUTCH HOUSING	CLOCHE EMBRAYAGE				FZ00384
CINGHIA DI TRASMISSIONE Bando	TRANSMISSION BELT Bando	COURROIE DE TRANSMISSION Bando				
CINGHIA DI TRASMISSIONE Mitsuboshi	TRANSMISSION BELT Mitsuboshi	COURROIE DE TRANSMISSION Mitsuboshi		9935470	9935500	9935500
CINGHIA DI TRASMISSIONE Altro	TRANSMISSION BELT Other	COURROIE DE TRANSMISSION Autres				
COLLETTORE ASPIRAZIONE	INLET MANIFOLD	COLLECTEUR ASPIRATION				
COLLETTORE ASPIRAZIONE SX	INLET MANIFOLD LEFT	COLLECTEUR ASPIRATION GAUCHE				
COLLETTORE ASPIRAZIONE DX	INLET MANIFOLD RIGHT	COLLECTEUR ASPIRATION DROITE				
FILTRO OLIO	OIL FILTER	FILTRE À HUILE			F007524	F007524
FRIZIONE	CLUTCH	EMBRAYAGE				
GRUPPO TERMICO Standard	CYLINDER KIT Ø standard	CYLINDRE COMPLET Standard				
GRUPPO TERMICO Maggiorato	CYLINDER KIT BIG BORE	CYLINDRE COMPLET Majoré				
KIT CUSCINETTI PARAOLI DI BANCO Serie	BEARINGS AND OIL SEALS KIT	KIT PALIERS JOINTS D'HUILE DE VILEBREQUIN Jeu				
KIT REVISIONE POMPA ACQUA	WATER PUMP REPAIR KIT	KIT RÉVISION POMPE À EAU				AA00824
KIT TAGLIANDO	SERVICE KIT	KIT COUPON				TG00112
MASSE CENTRIFUGHE PESO ORIGINALE	ROLLER WEIGHTS Standard weight	MASSELOTTE CENTRIFUGES POIDS D'ORIGINE				9935990
MEMBRANA CARBURATORE TIPO ORIGINALE	CARBURETOR DIAPHRAGM OEM	MEMBRANE CARBURATEUR TYPE ORIGINAL				
MEMBRANA CARBURATORE ADATTABILE	CARBURETOR DIAPHRAGM Adaptable	MEMBRANE CARBURATEUR ADAPTABLE				
MOLLE CONTRASTO VARIATORE	REAR VARIATOR SPRING	RESSORTS CONTRASTE VARIATEUR				9926780
MOLLA A GAS PER SELIA	SEAT GAS SPRING	RESSORT À GAZ POUR SELLE				
MOTORINO D'AVVIAMENTO	STARTER ENGINE	DÉMARREUR ÉLECTRIQUE			MA00030	MA00030
PIATTELLO PORTATASSELI	VARIATOR SLIDERS	CURSEURS VARIATEUR		PL04067		
POMPA BENZINA	FUEL PUMP	POMPE À ESSENCE				
PULEGGIA FISSA	FIXED SHEAVE	POULIE FIXE				
REGOLATORE DI TENSIONE	RECTIFIER	RÉGULATEUR DE TENSION				RE00004
RUOTA LIBERA Completa	STARTER CLUTCH SET	ROUE LIBRE Complète				
RUOTA LIBERA RL + flangia	STARTER CLUTCH + FLANGE	ROUE LIBRE RL + flasque				RL00021
RUOTA LIBERA RL nuda	STARTER CLUTCH	ROUE LIBRE RL nue				
RUOTA LIBERA Ingranaggio	STARTER CLUTCH GEAR	ROUE LIBRE Engrenage				RL00023
RUOTA LIBERA Flangia	STARTER CLUTCH FLANGE	ROUE LIBRE Flasque				
SERIE DISCHI FRIZIONE	CLUTCH PLATES KIT	JEU DISQUES EMBRAYAGE				
STATORE	STATOR	STATOR				
TASSELLI TRAINO	VARIATOR SLIDERS	CURSEURS VARIATEUR				
VARIATORE VARIOTOP TPR	VARIOTOP TPR	VARIOTOP TPR			9923250	9923250

PIAGGIO	PIAGGIO	PIAGGIO	PIAGGIO	PIAGGIO	PIAGGIO	PIAGGIO	PIAGGIO	PIAGGIO	PIAGGIO	PIAGGIO	PIAGGIO
MP3 MAXI SPORT E4 ABS	MP3 MIC	MP3 MIC	MP3 RL SPORT- BUSINESS	MP3 RL TOURING	MP3 SPORT ABS	MP3 YOURBAN ERL	MP3 YOURBAN ERL	MP3 YOURBAN LT ERL	SFERA	SKIPPER LX	SKIPPER LX
18-19	08-09	08-10	11-12	11-11	14-16	11-13	11-15	11-12	95-97	98-99	98-99
350cc 4T 4V LC	250cc 4T LC	400cc 4T LC	500cc 4T LC	400cc 4T LC	500cc 4T LC	125cc 4T LC	300cc 4T LC	300cc 4T LC	125cc 4T AC	125cc 2T AC	150cc 2T AC
Piaggio											
	FZ00395	FZ00384	FZ00384	FZ00384		FZ00395	FZ00395	FZ00395			
		9927630		9927630		9927650			9915370	9915350	9915350
9935490	9935470		9935500		9935500		9935470	9935470	9935690	9935670	9935670
									CT00739		
	F007515	F007524	F007524	F007524	F007524	F007515	F007515	F007515	F007514		
	FZ00382						FZ00382	FZ00382			
AA00829	AA00828	AA00824	AA00824	AA00824			AA00828	AA00828			
			TG00112								
			9935990				9931880	9931880			
		9926780	9926780	9926780							
	MA00016	MA00030	MA00030	MA00030	MA00030						
	PL04067					PL04067	PL04067	PL04067			
	RE00004	RE00004	RE00004	RE00004					RE00009		
RL00021	RL00041	RL00021	RL00021	RL00021							
	RL00023	RL00023	RL00023	RL00023		RL00023	RL00023	RL00023			
9931020											
	ST00023										
						AA00850			AA00850		
	9923650	9923250	9923250	9923250	9923250	9923600	9923650	9923650			

MAXI SCOOTER

TOP
- performances -



PIAGGIO	PIAGGIO	PIAGGIO	PIAGGIO
SKYPPER	SKYPPER	SKYPPER 4T	SKYPPER 4T
94-97	94-97	00-02	00-02
125cc 2T AC	150cc 2T AC	125cc 4T AC	150cc 4T AC

IT	EN	FR				
ALBERO A CAMME	CAM SHAFT	ARBRE À CAMES				
ALBERO MOTORE Sel 1/Sel 2	CRANKSHAFT Sel 1/Sel 2	VILEBREQUIN Sel 1/ Sel 2			IM070701 IM070702	
CAMPANA FRIZIONE	CLUTCH HOUSING	CLOCHE EMBRAYAGE			FZ00377	FZ00377
CINGHIA DI TRASMISSIONE Bando	TRANSMISSION BELT Bando	COURROIE DE TRANSMISSION Bando		9915360	9915350	9927650
CINGHIA DI TRASMISSIONE Mitsuboshi	TRANSMISSION BELT Mitsuboshi	COURROIE DE TRANSMISSION Mitsuboshi		9935680	9935670	
CINGHIA DI TRASMISSIONE Altro	TRANSMISSION BELT Other	COURROIE DE TRANSMISSION Autres				
COLLETTORE ASPIRAZIONE	INLET MANIFOLD	COLLECTEUR ASPIRATION		CT00728	CT00728	CT00740
COLLETTORE ASPIRAZIONE SX	INLET MANIFOLD LEFT	COLLECTEUR ASPIRATION GAUCHE				
COLLETTORE ASPIRAZIONE DX	INLET MANIFOLD RIGHT	COLLECTEUR ASPIRATION DROITE				
FILTRO OLIO	OIL FILTER	FILTRE À HUILE			F007515	F007515
FRIZIONE	CLUTCH	EMBAYAGE			FZ00396	FZ00378
GRUPPO TERMICO Standard	CYLINDER KIT Ø standard	CYLINDRE COMPLET Standard				
GRUPPO TERMICO Maggiorato	CYLINDER KIT BIG BORE	CYLINDRE COMPLET Majoré				
KIT CUSCINETTI PARAOLI DI BANCO Serie	BEARINGS AND OIL SEALS KIT	KIT PALIERS JOINTS D'HUILE DE VILEBREQUIN Jeu				
KIT REVISIONE POMPA ACQUA	WATER PUMP REPAIR KIT	KIT RÉVISION POMPE À EAU				
KIT TAGLIANDO	SERVICE KIT	KIT COUPON				
MASSE CENTRIFUGHE PESO ORIGINALE	ROLLER WEIGHTS Standard weight	MASSELOTTE CENTRIFUGES POIDS D'ORIGINE				
MEMBRANA CARBURATORE TIPO ORIGINALE	CARBURETOR DIAPHRAGM OEM	MEMBRANE CARBURATEUR TYPE ORIGINAL			MC12002	MC12002
MEMBRANA CARBURATORE ADATTABILE	CARBURETOR DIAPHRAGM Adaptable	MEMBRANE CARBURATEUR ADAPTABLE				
MOLLE CONTRASTO VARIATORE	REAR VARIATOR SPRING	RESSORTS CONTRASTE VARIATEUR				
MOLLA A GAS PER SELIA	SEAT GAS SPRING	RESSORT À GAZ POUR SELLE				
MOTORINO D'AVVIAMENTO	STARTER ENGINE	DÉMARREUR ÉLECTRIQUE			MA00012	MA00012
PIATTELLO PORTATASSELI	VARIATOR SLIDERS	CURSEURS VARIATEUR				
POMPA BENZINA	FUEL PUMP	POMPE À ESSENCE				
PULEGGIA FISSA	FIXED SHEAVE	POULIE FIXE			PL04072	PL04072
REGOLATORE DI TENSIONE	RECTIFIER	RÉGULATEUR DE TENSION			RE00011	
RUOTA LIBERA Completa	STARTER CLUTCH SET	ROUE LIBRE Complète				
RUOTA LIBERA RL + flangia	STARTER CLUTCH + FLANGE	ROUE LIBRE RL + flasque				
RUOTA LIBERA RL nuda	STARTER CLUTCH	ROUE LIBRE RL nue				
RUOTA LIBERA Ingranaggio	STARTER CLUTCH GEAR	ROUE LIBRE Engrenage			RL00022	RL00022
RUOTA LIBERA Flangia	STARTER CLUTCH FLANGE	ROUE LIBRE Flasque				
SERIE DISCHI FRIZIONE	CLUTCH PLATES KIT	JEU DISQUES EMBRAYAGE				
STATORE	STATOR	STATOR				
TASSELLI TRAINO	VARIATOR SLIDERS	CURSEURS VARIATEUR			AA00850	
VARIATORE VARIOTOP TPR	VARIOTOP TPR	VARIOTOP TPR			9923600	9923600

PIAGGIO	PIAGGIO	PIAGGIO	PIAGGIO	PIAGGIO	PIAGGIO	PIAGGIO	PIAGGIO	PIAGGIO	PIAGGIO	PIAGGIO	PIAGGIO
SUPER HEXAGON GTX 12	SUPER HEXAGON GTX 12	TYPHOON 4T 2V E3	VESPA 946 4T 3V ABS	VESPA 946 4T 3V ABS ARMANI	VESPA ET4	VESPA ET4	VESPA ET4	VESPA GRAN-TURISMO	VESPA GRAN-TURISMO	VESPA GRAN-TURISMO	VESPA GRAN-TURISMO
01-02	01-02	10-11	13-15	15-15	96-98	99-02	99-02	03-05	06-07	03-05	06-07
125cc 4T LC	180cc 4T LC	125cc 4T AC	125cc 4T-3V LC	125cc 4T-3V LC	125cc 4T AC	125cc 4T AC	150cc 4T AC	125cc 4T LC	125cc 4T LC	200cc 4T LC	200cc 4T LC
						Leader	Leader	Piaggio M311M			
		IM070701 IM070702						IM070701 IM070702	IM070701 IM070702		
FZ00377	FZ00377					FZ00377	FZ00377	FZ00395	FZ00395	FZ00377	FZ00395
9927650		9927650			9915370	9927650	9927650	9927650	9927650		
	9935920				9935690					9935920	9935920
CT00734		CT00736			CT00739	CT00740	CT00740	CT00734	CT00735		CT00735
F007515	F007515	F007515			F007514	F007515	F007515	F007515	F007515	F007515	F007515
FZ00396	FZ00378	FZ00418				FZ00396	FZ00378	FZ00396	FZ00396	FZ00378	
AA00817	AA00817							AA00817	AA00826		AA00826
								TG00111	TG00111		
	9932790									9932790	9932790
					MC12002	MC12002	MC12002				
								MC12107	MC12106	MC12106	MC12106
MA00012	MA00012	MA00012				MA00012	MA00012	MA00012	MA00012	MA00012	MA00012
PL04067		PL04067	PL04067	PL04067				PL04067			PL04067
PL04072		PL04072			PL04072	PL04072	PL04072	PL04072	PL04072		
RE00011	RE00011	RE00011			RE00012	RE00011		RE00011	RE00011	RE00011	RE00011
RL00022	RL00022	RL00022			RL00022	RL00022	RL00022	RL00022	RL00022	RL00022	RL00022
AA00850		AA00850			AA00850	AA00850			AA00850		AA00850
9923600	9923600				9923600	9923600	9923600	9923600	9923600	9923650	9923650

MAXI SCOOTER

TOP
- performances -



PIAGGIO	PIAGGIO	PIAGGIO	PIAGGIO
VESPA GRAN-TURISMO EU3	VESPA GT 60 EU3	VESPA GTS	VESPA GTS 4T IE SUPER
06-07	06-07	05-16	09-16
125cc 4T LC	250cc 4T LC	250cc 4T LC	125cc 4T LC
Piaggio M314M			Piaggio M455M

IT	EN	FR				
ALBERO A CAMME	CAM SHAFT	ARBRE À CAMES				
ALBERO MOTORE Sel 1/Sel 2	CRANKSHAFT Sel 1/Sel 2	VILEBREQUIN Sél 1/ Sél 2		IM070701 IM070702		
CAMPANA FRIZIONE	CLUTCH HOUSING	CLOCHE EMBRAYAGE		FZ00395	FZ00395	FZ00395
CINGHIA DI TRASMISSIONE Bando	TRANSMISSION BELT Bando	COURROIE DE TRANSMISSION Bando		9927650		9927650
CINGHIA DI TRASMISSIONE Mitsuboshi	TRANSMISSION BELT Mitsuboshi	COURROIE DE TRANSMISSION Mitsuboshi			9935470	9935470
CINGHIA DI TRASMISSIONE Altro	TRANSMISSION BELT Other	COURROIE DE TRANSMISSION Autres				
COLLETTORE ASPIRAZIONE	INLET MANIFOLD	COLLECTEUR ASPIRATION		CT00735		
COLLETTORE ASPIRAZIONE SX	INLET MANIFOLD LEFT	COLLECTEUR ASPIRATION GAUCHE				
COLLETTORE ASPIRAZIONE DX	INLET MANIFOLD RIGHT	COLLECTEUR ASPIRATION DROITE				
FILTRO OLIO	OIL FILTER	FILTRE À HUILE		F007515	F007515	F007515
FRIZIONE	CLUTCH	EMBAYAGE		FZ00396	FZ00382	FZ00382
GRUPPO TERMICO Standard	CYLINDER KIT Ø standard	CYLINDRE COMPLET Standard				
GRUPPO TERMICO Maggiorato	CYLINDER KIT BIG BORE	CYLINDRE COMPLET Majoré				
KIT CUSCINETTI PARAOLI DI BANCO Serie	BEARINGS AND OIL SEALS KIT	KIT PALIERS JOINTS D'HUILE DE VILEBREQUIN Jeu				
KIT REVISIONE POMPA ACQUA	WATER PUMP REPAIR KIT	KIT RÉVISION POMPE À EAU		AA00826	AA00828	AA00828
KIT TAGLIANDO	SERVICE KIT	KIT COUPON		TG00111		
MASSE CENTRIFUGHE PESO ORIGINALE	ROLLER WEIGHTS Standard weight	MASSELOTES CENTRIFUGES POIDS D'ORIGINE				
MEMBRANA CARBURATORE TIPO ORIGINALE	CARBURETOR DIAPHRAGM OEM	MEMBRANE CARBURATEUR TYPE ORIGINAL				
MEMBRANA CARBURATORE ADATTABILE	CARBURETOR DIAPHRAGM Adaptable	MEMBRANE CARBURATEUR ADAPTABLE		MC12106		
MOLLE CONTRASTO VARIATORE	REAR VARIATOR SPRING	RESSORTS CONTRASTE VARIATEUR				
MOLLA A GAS PER SELIA	SEAT GAS SPRING	RESSORT À GAZ POUR SELLE				
MOTORINO D'AVVIAMENTO	STARTER ENGINE	DÉMARREUR ÉLECTRIQUE		MA00012	MA00016	MA00016
PIATTELLO PORTATASSELI	VARIATOR SLIDERS	CURSEURS VARIATEUR		PL04067	PL04067	PL04067
POMPA BENZINA	FUEL PUMP	POMPE À ESSENCE				
PULEGGIA FISSA	FIXED SHEAVE	POULIE FIXE		PL04072		
REGOLATORE DI TENSIONE	RECTIFIER	RÉGULATEUR DE TENSION		RE00011	RE00004	RE00004
RUOTA LIBERA Completa	STARTER CLUTCH SET	ROUE LIBRE Complète				
RUOTA LIBERA RL + flangia	STARTER CLUTCH + FLANGE	ROUE LIBRE RL + flasque			RL00041	RL00041
RUOTA LIBERA RL nuda	STARTER CLUTCH	ROUE LIBRE RL nue				
RUOTA LIBERA Ingranaggio	STARTER CLUTCH GEAR	ROUE LIBRE Engrenage		RL00022	RL00023	RL00023
RUOTA LIBERA Flangia	STARTER CLUTCH FLANGE	ROUE LIBRE Flasque				
SERIE DISCHI FRIZIONE	CLUTCH PLATES KIT	JEU DISQUES EMBRAYAGE				
STATORE	STATOR	STATOR			ST00023	ST00023
TASSELLI TRAINO	VARIATOR SLIDERS	CURSEURS VARIATEUR		AA00850		AA00850
VARIATORE VARIOTOP TPR	VARIOTOP TPR	VARIOTOP TPR		9923600	9923650	9923650

PIAGGIO	PIAGGIO	PIAGGIO	PIAGGIO	PIAGGIO	PIAGGIO	PIAGGIO	PIAGGIO	PIAGGIO	PIAGGIO	PIAGGIO	PIAGGIO
VESPA GTS ABS	VESPA GTS EU3	VESPA GTS EU3	VESPA GTS IE & TOURING	VESPA GTS IE TOURING	VESPA GTS SUPER	VESPA GTS SUPER IE 4T 3V	VESPA GTS SUPER SPORT	VESPA GTV	VESPA GTV	VESPA GTV 4T 4V IE	VESPA GTV 4T NAVY EU3
05-12	07-12	07-12	12-16	11-12	08-16	14-15	10-13	06-08	06-09	10-13	08-08
250cc 4T LC	125cc 4T LC	200cc 4T LC	300cc 4T LC	300cc 4T LC	300cc 4T LC	150cc 4T-3V LC	300cc 4T LC	125cc 4T LC	250cc 4T LC	300cc 4T LC	125cc 4T LC
	Piaggio M315M				Piaggio M454M						
	IM070701 IM070702							IM070701 IM070702			IM070701 IM070702
FZ00395		FZ00377			FZ00395				FZ00395		
	9927650							9927650			9927650
9935470			9935470	9935470	9935470		9935470		9935470	9935470	
								CT00735			
F007515	F007515			F007515	F007515		F007515	F007515	F007515	F007515	F007515
FZ00382	FZ00396	FZ00378						FZ00396	FZ00382		FZ00396
AA00828	AA00826			AA00828	AA00828		AA00828	AA00826	AA00828	AA00828	AA00826
	TG00111							TG00111			TG00111
				9931880	9931880		9931880			9931880	
	MC12106							MC12106			MC12106
MA00016	MA00012			MA00016	MA00016		MA00016	MA00012	MA00016	MA00016	MA00012
PL04067	PL04067		PL04067	PL04067	PL04067	PL04067	PL04067	PL04067	PL04067	PL04067	PL04067
	PL04072							PL04072			PL04072
RE00004	RE00011				RE00004			RE00011	RE00004		RE00011
RL00021				RL00021	RL00021		RL00021		RL00041	RL00021	
RL00023	RL00022			RL00023	RL00023		RL00023	RL00022	RL00023	RL00023	RL00022
ST00023									ST00023		
	AA00850							AA00850			AA00850
9923650	9923600	9923650			9923650			9923600	9923650		9923600

MAXI SCOOTER



MAXI SCOOTER

TOP
- performances -



PIAGGIO	PIAGGIO	PIAGGIO	PIAGGIO
VESPA GTV 4T NAVY EU3	VESPA GTV EU3	VESPA GTV VIA MONTENAPOLEONE	VESPA LX
07-07	06-08	10-10	05-06
250cc 4T LC	200cc 4T LC	300cc 4T LC	125cc 4T AC

IT	EN	FR	Image				Part Number
ALBERO A CAMME	CAM SHAFT	ARBRE À CAMES					
ALBERO MOTORE Sel 1/Sel 2	CRANKSHAFT Sel 1/Sel 2	VILEBREQUIN Sél 1/ Sél 2					IM070701 IM070702
CAMPANA FRIZIONE	CLUTCH HOUSING	CLOCHE EMBRAYAGE					FZ00377 FZ00395
CINGHIA DI TRASMISSIONE Bando	TRANSMISSION BELT Bando	COURROIE DE TRANSMISSION Bando					9927650
CINGHIA DI TRASMISSIONE Mitsuboshi	TRANSMISSION BELT Mitsuboshi	COURROIE DE TRANSMISSION Mitsuboshi					9935470
CINGHIA DI TRASMISSIONE Altro	TRANSMISSION BELT Other	COURROIE DE TRANSMISSION Autres					
COLLETTORE ASPIRAZIONE	INLET MANIFOLD	COLLECTEUR ASPIRATION					CT00736
COLLETTORE ASPIRAZIONE SX	INLET MANIFOLD LEFT	COLLECTEUR ASPIRATION GAUCHE					
COLLETTORE ASPIRAZIONE DX	INLET MANIFOLD RIGHT	COLLECTEUR ASPIRATION DROITE					
FILTRO OLIO	OIL FILTER	FILTRE À HUILE					F007515 F007515
FRIZIONE	CLUTCH	EMBRAYAGE					FZ00378
GRUPPO TERMICO Standard	CYLINDER KIT Ø standard	CYLINDRE COMPLET Standard					
GRUPPO TERMICO Maggiore	CYLINDER KIT BIG BORE	CYLINDRE COMPLET Majoré					
KIT CUSCINETTI PARAOLI DI BANCO Serie	BEARINGS AND OIL SEALS KIT	KIT PALIERS JOINTS D'HUILE DE VILEBREQUIN Jeu					
KIT REVISIONE POMPA ACQUA	WATER PUMP REPAIR KIT	KIT RÉVISION POMPE À EAU					AA00828 AA00828
KIT TAGLIANDO	SERVICE KIT	KIT COUPON					
MASSE CENTRIFUGHE PESO ORIGINALE	ROLLER WEIGHTS Standard weight	MASSELOTES CENTRIFUGES POIDS D'ORIGINE					9931880
MEMBRANA CARBURATORE TIPO ORIGINALE	CARBURETOR DIAPHRAGM OEM	MEMBRANE CARBURATEUR TYPE ORIGINAL					
MEMBRANA CARBURATORE ADATTABILE	CARBURETOR DIAPHRAGM Adaptable	MEMBRANE CARBURATEUR ADAPTABLE					MC12107
MOLLE CONTRASTO VARIATORE	REAR VARIATOR SPRING	RESSORTS CONTRASTE VARIATEUR					
MOLLA A GAS PER SELIA	SEAT GAS SPRING	RESSORT À GAZ POUR SELLE					
MOTORINO D'AVVIAMENTO	STARTER ENGINE	DÉMARREUR ÉLECTRIQUE					MA00016 MA00016 MA00012
PIATTELLO PORTATASSELLI	VARIATOR SLIDERS	CURSEURS VARIATEUR					PL04067 PL04067 PL04067
POMPA BENZINA	FUEL PUMP	POMPE À ESSENCE					
PULEGGIA FISSA	FIXED SHEAVE	POULIE FIXE					PL04072
REGOLATORE DI TENSIONE	RECTIFIER	RÉGULATEUR DE TENSION					RE00004 RE00011
RUOTA LIBERA Completa	STARTER CLUTCH SET	ROUE LIBRE Complète					
RUOTA LIBERA RL + flangia	STARTER CLUTCH + FLANGE	ROUE LIBRE RL + flasque					RL00041 RL00021
RUOTA LIBERA RL nuda	STARTER CLUTCH	ROUE LIBRE RL nue					
RUOTA LIBERA Ingranaggio	STARTER CLUTCH GEAR	ROUE LIBRE Engrenage					RL00023 RL00023 RL00022
RUOTA LIBERA Flangia	STARTER CLUTCH FLANGE	ROUE LIBRE Flasque					
SERIE DISCHI FRIZIONE	CLUTCH PLATES KIT	JEU DISQUES EMBRAYAGE					
STATORE	STATOR	STATOR					ST00023 ST00023
TASSELLI TRAINO	VARIATOR SLIDERS	CURSEURS VARIATEUR					AA00850
VARIATORE VARIOTOP TPR	VARIOTOP TPR	VARIOTOP TPR					9923650 9923650 9923600

PIAGGIO	PIAGGIO	PIAGGIO	PIAGGIO	PIAGGIO	PIAGGIO	PIAGGIO	PIAGGIO	PIAGGIO	PIAGGIO	PIAGGIO	PIAGGIO
VESPA LX	VESPA LX 4T 3V IE	VESPA LX 4T 3V IE - TOURING	VESPA LX 4T 3V IE - TOURING	VESPA LX 4T EU3 TOURING	VESPA LX 4T FL	VESPA LX 4T FL	VESPA LX EU3	VESPA LX EU3	VESPA LX EU3 IE	VESPA LX EU3 IE	VESPA LX TOURING
05-06	14-14	12-13	12-13	10-11	09-09	09-09	06-08	06-08	09-11	09-11	10-12
150cc 4T AC	150cc 4T-3V LC	125cc 4T-3V LC	150cc 4T-3V LC	125cc 4T AC	125cc 4T AC	150cc 4T AC	125cc 4T AC	150cc 4T AC	125cc 4T AC	150cc 4T AC	150cc 4T AC
IM070701 IM070702				IM070701 IM070702	IM070701 IM070702	IM070701 IM070702	IM070701 IM070702	IM070701 IM070702	IM070701 IM070702	IM070701 IM070702	IM070701 IM070702
FZ00395				FZ00395	FZ00395		FZ00395	FZ00395	FZ00395	FZ00395	
9927650				9927650	9927650	9927650	9927650	9927650	9927650	9927650	9927650
CT00736							CT00736	CT00736			
F007515				F007515	F007515	F007515	F007515	F007515	F007515	F007515	F007515
				FZ00418						FZ00418	FZ00418
MC12107					MC12107	MC12107	MC12107	MC12107	MC12107		
MA00012				MA00012	MA00012	MA00012	MA00012	MA00012	MA00012	MA00012	MA00012
PL04067	PL04067	PL04067	PL04067	PL04067	PL04067	PL04067	PL04067	PL04067	PL04067	PL04067	PL04067
PL04072				PL04072	PL04072	PL04072	PL04072	PL04072	PL04072	PL04072	PL04072
RE00011					RE00011	RE00011	RE00011	RE00011			
RL00022				RL00022	RL00022	RL00022	RL00022	RL00022	RL00022	RL00022	RL00022
AA00850				AA00850	AA00850	AA00850	AA00850	AA00850	AA00850	AA00850	AA00850
9923600				9923600	9923600	9923600	9923600	9923600	9923600	9923600	9923600

MAXI SCOOTER

MAXI SCOOTER

TOP
- performances -



PIAGGIO	PIAGGIO	PIAGGIO	PIAGGIO
VESPA LXV 4T EU3	VESPA LXV IE 4T	VESPA LXV NAVY EU3	VESPA PRIMAVERA 4T 3V
06-09	10-13	07-08	13-16
125cc 4T LC	125cc 4T LC	125cc 4T LC	150cc 4T-3V LC

IT	EN	FR				
ALBERO A CAMME	CAM SHAFT	ARBRE À CAMES				
ALBERO MOTORE Sel 1/Sel 2	CRANKSHAFT Sel 1/Sel 2	VILEBREQUIN Sél 1/ Sél 2		IM070701 IM070702	IM070701 IM070702	IM070701 IM070702
CAMPANA FRIZIONE	CLUTCH HOUSING	CLOCHE EMBRAYAGE		FZ00395	FZ00395	FZ00395
CINGHIA DI TRASMISSIONE Bando	TRANSMISSION BELT Bando	COURROIE DE TRANSMISSION Bando		9927650	9927650	9927650
CINGHIA DI TRASMISSIONE Mitsuboshi	TRANSMISSION BELT Mitsuboshi	COURROIE DE TRANSMISSION Mitsuboshi				
CINGHIA DI TRASMISSIONE Altro	TRANSMISSION BELT Other	COURROIE DE TRANSMISSION Autres				
COLLETTORE ASPIRAZIONE	INLET MANIFOLD	COLLECTEUR ASPIRATION		CT00736		
COLLETTORE ASPIRAZIONE SX	INLET MANIFOLD LEFT	COLLECTEUR ASPIRATION GAUCHE				
COLLETTORE ASPIRAZIONE DX	INLET MANIFOLD RIGHT	COLLECTEUR ASPIRATION DROITE				
FILTRO OLIO	OIL FILTER	FILTRE À HUILE		F007515	F007515	F007515
FRIZIONE	CLUTCH	EMBAYAGE			FZ00418	
GRUPPO TERMICO Standard	CYLINDER KIT Ø standard	CYLINDRE COMPLET Standard				
GRUPPO TERMICO Maggiorato	CYLINDER KIT BIG BORE	CYLINDRE COMPLET Majoré				
KIT CUSCINETTI PARAOLI DI BANCO Serie	BEARINGS AND OIL SEALS KIT	KIT PALIERS JOINTS D'HUILE DE VILEBREQUIN Jeu				
KIT REVISIONE POMPA ACQUA	WATER PUMP REPAIR KIT	KIT RÉVISION POMPE À EAU				
KIT TAGLIANDO	SERVICE KIT	KIT COUPON				
MASSE CENTRIFUGHE PESO ORIGINALE	ROLLER WEIGHTS Standard weight	MASSELOTTE CENTRIFUGES POIDS D'ORIGINE				
MEMBRANA CARBURATORE TIPO ORIGINALE	CARBURETOR DIAPHRAGM OEM	MEMBRANE CARBURATEUR TYPE ORIGINAL				
MEMBRANA CARBURATORE ADATTABILE	CARBURETOR DIAPHRAGM Adaptable	MEMBRANE CARBURATEUR ADAPTABLE		MC12107		MC12107
MOLLE CONTRASTO VARIATORE	REAR VARIATOR SPRING	RESSORTS CONTRASTE VARIATEUR				
MOLLA A GAS PER SELIA	SEAT GAS SPRING	RESSORT À GAZ POUR SELLE				
MOTORINO D'AVVIAMENTO	STARTER ENGINE	DÉMARREUR ÉLECTRIQUE		MA00012	MA00012	MA00012
PIATTELLO PORTATASSELI	VARIATOR SLIDERS	CURSEURS VARIATEUR		PL04067	PL04067	PL04067
POMPA BENZINA	FUEL PUMP	POMPE À ESSENCE				
PULEGGIA FISSA	FIXED SHEAVE	POULIE FIXE		PL04072	PL04072	PL04072
REGOLATORE DI TENSIONE	RECTIFIER	RÉGULATEUR DE TENSION		RE00011		RE00011
RUOTA LIBERA Completa	STARTER CLUTCH SET	ROUE LIBRE Complète				
RUOTA LIBERA RL + flangia	STARTER CLUTCH + FLANGE	ROUE LIBRE RL + flasque				
RUOTA LIBERA RL nuda	STARTER CLUTCH	ROUE LIBRE RL nue				
RUOTA LIBERA Ingranaggio	STARTER CLUTCH GEAR	ROUE LIBRE Engrenage		RL00022	RL00022	RL00022
RUOTA LIBERA Flangia	STARTER CLUTCH FLANGE	ROUE LIBRE Flasque				
SERIE DISCHI FRIZIONE	CLUTCH PLATES KIT	JEU DISQUES EMBRAYAGE				
STATORE	STATOR	STATOR				
TASSELLI TRAINO	VARIATOR SLIDERS	CURSEURS VARIATEUR		AA00850	AA00850	AA00850
VARIATORE VARIOTOP TPR	VARIOTOP TPR	VARIOTOP TPR		9923600	9923600	9923600

PIAGGIO	PIAGGIO	PIAGGIO	PIAGGIO	PIAGGIO	PIAGGIO	PIAGGIO	PIAGGIO	PIAGGIO	PIAGGIO	PIAGGIO	PIAGGIO
VESPA S 4T	VESPA S 4T 3V IE	VESPA S 4T EU3	VESPA S 4T IE & COLLEGE	VESPA S 4T IE & COLLEGE	X-EVO	X-EVO	X-EVO	X10 4T 4V EU3	X10 4T 4V IE EURO3	X10 4T-4V IE EU3	X7 EU3
08-09	12-12	07-08	09-11	09-12	07-16	07-16	07-11	12-15	12-15	12-14	08-08
150cc 4T AC	125cc 4T-3V LC	125cc 4T AC	125cc 4T AC	150cc 4T AC	125cc 4T LC	250cc 4T LC	400cc 4T LC	125cc 4T-4V LC	350cc 4T LC	500cc 4T LC	125cc 4T LC
Piaggio M445M		Piaggio M444M					Piaggio M521M		Piaggio		Leader
IM070701 IM070702		IM070701 IM070702	IM070701 IM070702	IM070701 IM070702	IM070701 IM070702						IM070701 IM070702
		FZ00395	FZ00395		FZ00395	FZ00395	FZ00384				FZ00395
9927650		9927650	9927650	9927650	9927650		9927630	9928540			9927650
						9935470			9935490	9935500	
F007515		F007515	F007515	F007515	F007515	F007515	F007524			F007524	F007515
FZ00418		FZ00418	FZ00418		FZ00396	FZ00382					FZ00396
						AA00826	AA00828	AA00824		AA00829	AA00826
						TG00111				TG00112	
								9924530		9935990	
MC12107		MC12107			MC12106						MC12106
								9926780			
MA00012		MA00012	MA00012	MA00012	MA00012	MA00016	MA00030			MA00030	MA00012
PL04067	PL04067	PL04067	PL04067	PL04067	PL04067	PL04067		PL04067			PL04067
PL04072		PL04072	PL04072	PL04072	PL04072						PL04072
RE00011		RE00011			RE00011	RE00004	RE00004				RE00011
						RL00041	RL00021		RL00021		
RL00022		RL00022	RL00022	RL00022	RL00022	RL00023	RL00023		RL00023		RL00022
									9931020		
						ST00023	ST00005				
AA00850		AA00850		AA00850	AA00850			AA00850			AA00850
9923600		9923600	9923600	9923600	9923600	9923650	9923250			9923250	9923600

MAXI SCOOTER

MAXI SCOOTER

TOP
- performances -



PIAGGIO	PIAGGIO	PIAGGIO	PIAGGIO
X7 EU3	X7 EVO IE EU3	X7 EVO IE EU3	X8
08-08	09-10	09-10	04-04
250cc 4T LC	125cc 4T LC	300cc 4T LC	125cc 4T LC
Piaggio M622M		Piaggio M624M	Leader

IT	EN	FR				
ALBERO A CAMME	CAM SHAFT	ARBRE À CAMES				
ALBERO MOTORE Sel 1/Sel 2	CRANKSHAFT Sel 1/Sel 2	VILEBREQUIN Sel 1/ Sel 2				IM070701 IM070702
CAMPANA FRIZIONE	CLUTCH HOUSING	CLOCHE EMBRAYAGE		FZ00395	FZ00395	FZ00395
CINGHIA DI TRASMISSIONE Bando	TRANSMISSION BELT Bando	COURROIE DE TRANSMISSION Bando			9927650	9927650
CINGHIA DI TRASMISSIONE Mitsuboshi	TRANSMISSION BELT Mitsuboshi	COURROIE DE TRANSMISSION Mitsuboshi		9935470		9935470
CINGHIA DI TRASMISSIONE Altro	TRANSMISSION BELT Other	COURROIE DE TRANSMISSION Autres				
COLLETTORE ASPIRAZIONE	INLET MANIFOLD	COLLECTEUR ASPIRATION				CT00735
COLLETTORE ASPIRAZIONE SX	INLET MANIFOLD LEFT	COLLECTEUR ASPIRATION GAUCHE				
COLLETTORE ASPIRAZIONE DX	INLET MANIFOLD RIGHT	COLLECTEUR ASPIRATION DROITE				
FILTRO OLIO	OIL FILTER	FILTRE À HUILE		F007515	F007515	F007515
FRIZIONE	CLUTCH	EMBRAYAGE			FZ00396	FZ00396
GRUPPO TERMICO Standard	CYLINDER KIT Ø standard	CYLINDRE COMPLET Standard				
GRUPPO TERMICO Maggiorato	CYLINDER KIT BIG BORE	CYLINDRE COMPLET Majoré				
KIT CUSCINETTI PARAOLI DI BANCO Serie	BEARINGS AND OIL SEALS KIT	KIT PALIERS JOINTS D'HUILE DE VILEBREQUIN Jeu				
KIT REVISIONE POMPA ACQUA	WATER PUMP REPAIR KIT	KIT RÉVISION POMPE À EAU		AA00828		AA00828 AA00817
KIT TAGLIANDO	SERVICE KIT	KIT COUPON				
MASSE CENTRIFUGHE PESO ORIGINALE	ROLLER WEIGHTS Standard weight	MASSELOTES CENTRIFUGES POIDS D'ORIGINE				9931880
MEMBRANA CARBURATORE TIPO ORIGINALE	CARBURETOR DIAPHRAGM OEM	MEMBRANE CARBURATEUR TYPE ORIGINAL				
MEMBRANA CARBURATORE ADATTABILE	CARBURETOR DIAPHRAGM Adaptable	MEMBRANE CARBURATEUR ADAPTABLE				
MOLLE CONTRASTO VARIATORE	REAR VARIATOR SPRING	RESSORTS CONTRASTE VARIATEUR				
MOLLA A GAS PER SELIA	SEAT GAS SPRING	RESSORT À GAZ POUR SELLE				
MOTORINO D'AVVIAMENTO	STARTER ENGINE	DÉMARREUR ÉLECTRIQUE		MA00016	MA00016	MA00016 MA00012
PIATTELLO PORTATASSELI	VARIATOR SLIDERS	CURSEURS VARIATEUR		PL04067	PL04067	PL04067
POMPA BENZINA	FUEL PUMP	POMPE À ESSENCE				
PULEGGIA FISSA	FIXED SHEAVE	POULIE FIXE				PL04060 PL04072
REGOLATORE DI TENSIONE	RECTIFIER	RÉGULATEUR DE TENSION		RE00004		RE00011
RUOTA LIBERA Completa	STARTER CLUTCH SET	ROUE LIBRE Complète				
RUOTA LIBERA RL + flangia	STARTER CLUTCH + FLANGE	ROUE LIBRE RL + flasque		RL00041	RL00041	RL00021
RUOTA LIBERA RL nuda	STARTER CLUTCH	ROUE LIBRE RL nue				
RUOTA LIBERA Ingranaggio	STARTER CLUTCH GEAR	ROUE LIBRE Engrenage		RL00023	RL00023	RL00023 RL00022
RUOTA LIBERA Flangia	STARTER CLUTCH FLANGE	ROUE LIBRE Flasque				
SERIE DISCHI FRIZIONE	CLUTCH PLATES KIT	JEU DISQUES EMBRAYAGE				
STATORE	STATOR	STATOR		ST00023		
TASSELLI TRAINO	VARIATOR SLIDERS	CURSEURS VARIATEUR			AA00850	AA00850
VARIATORE VARIOTOP TPR	VARIOTOP TPR	VARIOTOP TPR		9923650	9923600	9923650 9923600

PIAGGIO	PIAGGIO	PIAGGIO	PIAGGIO	PIAGGIO	PIAGGIO	PIAGGIO	PIAGGIO	PIAGGIO	PIAGGIO	PIAGGIO	PIAGGIO
X8	X8	X8	X8 EU3	X8 EU3	X8 PREMIUM EU2	X8 PREMIUM EU3	X8 STREET EU2	X8 STREET EU2	X9	X9	X9
05-06	04-04	05-07	05-08	06-08	06-06	06-07	06-07	06-08	01-02	02-03	00-01
125cc 4T LC	200cc 4T LC	200cc 4T LC	250cc 4T LC	400cc 4T LC	125cc 4T LC	125cc 4T LC	125cc 4T AC	150cc 4T AC	125cc 4T LC	200cc 4T LC	250cc 4T LC
			Quasar	Piaggio M521M							Motore Honda
IM070701 IM070702					IM070701 IM070702	IM070701 IM070702	IM070701 IM070702	IM070701 IM070702	IM070701 IM070702		
FZ00395	FZ00395	FZ00395		FZ00384				FZ00395	FZ00377		
9927650				9927630	9927650	9927650	9927650	9927650	9927650		9917990
	9935920	9935920	9935470							9935920	9935720
CT00735	CT00735	CT00735			CT00735		CT00736	CT00736	CT00734	CT00734	
F007515	F007515	F007515	F007515	F007524	F007515	F007515	F007515	F007515	F007515	F007515	
FZ00396	FZ00378		FZ00382				FZ00418	FZ00418	FZ00396		FZ00390 FZ00392
AA00826	AA00817	AA00826	AA00828		AA00826	AA00826			AA00817	AA00817	
					TG00111	TG00111					
	9932790	9932790		9924530						9932790	
MC12106		MC12106			MC12106	MC12106	MC12107	MC12107	MC12002		
				9926780							
MA00012		MA00012	MA00016	MA00030	MA00012	MA00012	MA00012	MA00012	MA00012	MA00012	MA00012
PL04067		PL04067	PL04067		PL04067	PL04067	PL04067	PL04067	PL04067	PL04067	PL04067
PL04072					PL04072	PL04072	PL04072	PL04072	PL04072	PL04072	
RE00011		RE00011	RE00004	RE00004	RE00011	RE00011	RE00011	RE00011	RE00011	RE00011	RE00011
			RL00041	RL00021							
RL00022	RL00022	RL00022	RL00023	RL00023	RL00022	RL00022	RL00022	RL00022	RL00022	RL00022	RL00022
			ST00023	ST00005							
AA00850		AA00850			AA00850	AA00850	AA00850	AA00850	AA00850	AA00850	AA00850
9923600	9923650	9923650	9923650	9923250	9923600	9923600		9923600	9923600	9923650	

MAXI SCOOTER

MAXI SCOOTER

TOP
- performances -



PIAGGIO	PIAGGIO	PIAGGIO	PIAGGIO
X9	X9 AMALFI	X9 EVOLUTION	X9 EVOLUTION
01-02	00-03	03-03	05-06
500cc 4T LC	180cc 4T LC	125cc 4T LC	125cc 4T LC

IT	EN	FR				
ALBERO A CAMME	CAM SHAFT	ARBRE À CAMES				
ALBERO MOTORE Sel 1/Sel 2	CRANKSHAFT Sel 1/Sel 2	VILEBREQUIN Sél 1/ Sél 2				IM070701 IM070702
CAMPANA FRIZIONE	CLUTCH HOUSING	CLOCHE EMBRAYAGE		FZ00384	FZ00377	
CINGHIA DI TRASMISSIONE Bando	TRANSMISSION BELT Bando	COURROIE DE TRANSMISSION Bando				9927650
CINGHIA DI TRASMISSIONE Mitsuboshi	TRANSMISSION BELT Mitsuboshi	COURROIE DE TRANSMISSION Mitsuboshi		9935460	9935920	
CINGHIA DI TRASMISSIONE Altro	TRANSMISSION BELT Other	COURROIE DE TRANSMISSION Autres				
COLLETTORE ASPIRAZIONE	INLET MANIFOLD	COLLECTEUR ASPIRATION			CT00734	CT00734
COLLETTORE ASPIRAZIONE SX	INLET MANIFOLD LEFT	COLLECTEUR ASPIRATION GAUCHE				
COLLETTORE ASPIRAZIONE DX	INLET MANIFOLD RIGHT	COLLECTEUR ASPIRATION DROITE				CT00735
FILTRO OLIO	OIL FILTER	FILTRE À HUILE		F007524	F007515	F007515
FRIZIONE	CLUTCH	EMBAYAGE		FZ00383	FZ00378	
GRUPPO TERMICO Standard	CYLINDER KIT Ø standard	CYLINDRE COMPLET Standard				
GRUPPO TERMICO Maggiorato	CYLINDER KIT BIG BORE	CYLINDRE COMPLET Majoré				
KIT CUSCINETTI PARAOLI DI BANCO Serie	BEARINGS AND OIL SEALS KIT	KIT PALIERS JOINTS D'HUILE DE VILEBREQUIN Jeu				
KIT REVISIONE POMPA ACQUA	WATER PUMP REPAIR KIT	KIT RÉVISION POMPE À EAU			AA00817	AA00817
KIT TAGLIANDO	SERVICE KIT	KIT COUPON				
MASSE CENTRIFUGHE PESO ORIGINALE	ROLLER WEIGHTS Standard weight	MASSELOTES CENTRIFUGES POIDS D'ORIGINE		9922330	9932790	
MEMBRANA CARBURATORE TIPO ORIGINALE	CARBURETOR DIAPHRAGM OEM	MEMBRANE CARBURATEUR TYPE ORIGINAL				
MEMBRANA CARBURATORE ADATTABILE	CARBURETOR DIAPHRAGM Adaptable	MEMBRANE CARBURATEUR ADAPTABLE				MC12106
MOLLE CONTRASTO VARIATORE	REAR VARIATOR SPRING	RESSORTS CONTRASTE VARIATEUR		9926780		
MOLLA A GAS PER SELIA	SEAT GAS SPRING	RESSORT À GAZ POUR SELLE				
MOTORINO D'AVVIAMENTO	STARTER ENGINE	DÉMARREUR ÉLECTRIQUE		MA00030	MA00012	MA00012
PIATTELLO PORTATASSELI	VARIATOR SLIDERS	CURSEURS VARIATEUR			PL04067	PL04067
POMPA BENZINA	FUEL PUMP	POMPE À ESSENCE				
PULEGGIA FISSA	FIXED SHEAVE	POULIE FIXE				PL04060 PL04072
REGOLATORE DI TENSIONE	RECTIFIER	RÉGULATEUR DE TENSION		RE00004	RE00011	RE00011
RUOTA LIBERA Completa	STARTER CLUTCH SET	ROUE LIBRE Complète				
RUOTA LIBERA RL + flangia	STARTER CLUTCH + FLANGE	ROUE LIBRE RL + flasque		RL00021		
RUOTA LIBERA RL nuda	STARTER CLUTCH	ROUE LIBRE RL nue				
RUOTA LIBERA Ingranaggio	STARTER CLUTCH GEAR	ROUE LIBRE Engrenage		RL00023	RL00022	RL00022
RUOTA LIBERA Flangia	STARTER CLUTCH FLANGE	ROUE LIBRE Flasque				
SERIE DISCHI FRIZIONE	CLUTCH PLATES KIT	JEU DISQUES EMBRAYAGE				
STATORE	STATOR	STATOR		ST00005		
TASSELLI TRAINO	VARIATOR SLIDERS	CURSEURS VARIATEUR			AA00850	AA00850
VARIATORE VARIOTOP TPR	VARIOTOP TPR	VARIOTOP TPR		9923250		9923600

PIAGGIO	PIAGGIO	PIAGGIO	PIAGGIO	PIAGGIO	PIAGGIO	PIAGGIO	PIAGGIO	RENAULT	SUZUKI	SUZUKI	SUZUKI
X9 EVOLUTION	X9 EVOLUTION	X9 EVOLUTION	X9 EVOLUTION	X9 EVOLUTION	X9 EVOLUTION ABS	X9 EVOLUTION EU3	ZIP	FULLTIME	AN BURGMAN K1/K2	AN BURGMAN K3-K5	AN BURGMAN K3/K6
03-03	04-04	06-06	03-05	06-07	06-07	07-07	00-02	02-03	01-02	03-05	03-06
200cc 4T LC	250cc 4T LC	250cc 4T LC	500cc 4T LC	500cc 4T LC	500cc 4T LC	125cc 4T LC	125cc 4T AC	125cc 4T AC	250cc 4T LC	650cc 4T LC	250cc 4T LC
	Piaggio M237M		Piaggio	Piaggio	Piaggio		Leader	Leader			
						IM070701 IM070702	IM070701 IM070702				IM07050
			FZ00384	FZ00384			FZ00377	FZ00377			
			9927630	9927630	9927630	9927650	9927650	9927650	9915790		9915790
9935920	9935470	9935470							9935510		
CT00734	CT00735	CT00735					CT00740				
F007515	F007515	F007515	F007524	F007524	F007524	F007515	F007515	F007515	F007510	F007511	F007510
			FZ00383	FZ00383			FZ00396	FZ00378	FZ00392		FZ00392
											KK01006
AA00817		AA00828				AA00826		AA00817	AA00819		AA00819
						TG00111				TG00119	
9932790			9922330	9935990	9935990						
							MC12002				
	MC12106	MC12106				MC12106					
			9926780	9926780	9926780						
MA00012	MA00016	MA00016	MA00030	MA00030	MA00030	MA00012	MA00012		MA00021		MA00021
PL04067	PL04067	PL04067				PL04067	PL04067				
						PL04072	PL04072				
RE00011	RE00011	RE00011	RE00004	RE00004	RE00004	RE00011	RE00011				
									RL00018		RL00018
	RL00021	RL00021	RL00021	RL00021							
RL00022	RL00023	RL00023	RL00023	RL00023	RL00023	RL00022	RL00022				
			ST00005	ST00005	ST00005						
AA00850	AA00850					AA00850	AA00850		AA00853		AA00853
	9923650	9923650	9923250	9923250	9923250	9923600	9923600	9923600	9923790		9923790

MAXI SCOOTER

TOP
- performances -



SUZUKI	SUZUKI	SUZUKI	SUZUKI
AN BURGMAN K3/K6	AN BURGMAN K6-L0	AN BURGMAN K7/L0	AN BURGMAN L1
03-06	06-10	07-10	11-11
400cc 4T LC	650cc 4T LC	400cc 4T LC	400cc 4T LC

IT	EN	FR				
ALBERO A CAMME	CAM SHAFT	ARBRE À CAMES				
ALBERO MOTORE Sel 1/Sel 2	CRANKSHAFT Sel 1/Sel 2	VILEBREQUIN Sel 1/ Sel 2				
CAMPANA FRIZIONE	CLUTCH HOUSING	CLOCHE EMBRAYAGE			FZ00402	FZ00402
CINGHIA DI TRASMISSIONE Bando	TRANSMISSION BELT Bando	COURROIE DE TRANSMISSION Bando		9920430	9927660	9927660
CINGHIA DI TRASMISSIONE Mitsuboshi	TRANSMISSION BELT Mitsuboshi	COURROIE DE TRANSMISSION Mitsuboshi		9935730		
CINGHIA DI TRASMISSIONE Altro	TRANSMISSION BELT Other	COURROIE DE TRANSMISSION Autres				
COLLETTORE ASPIRAZIONE	INLET MANIFOLD	COLLECTEUR ASPIRATION				
COLLETTORE ASPIRAZIONE SX	INLET MANIFOLD LEFT	COLLECTEUR ASPIRATION GAUCHE				
COLLETTORE ASPIRAZIONE DX	INLET MANIFOLD RIGHT	COLLECTEUR ASPIRATION DROITE				
FILTRO OLIO	OIL FILTER	FILTRE À HUILE		F007510	F007522	F007522
FRIZIONE	CLUTCH	EMBRAYAGE		FZ00403	FZ00419	FZ00419
GRUPPO TERMICO Standard	CYLINDER KIT Ø standard	CYLINDRE COMPLET Standard				
GRUPPO TERMICO Maggiorato	CYLINDER KIT BIG BORE	CYLINDRE COMPLET Majoré				
KIT CUSCINETTI PARAOLI DI BANCO Serie	BEARINGS AND OIL SEALS KIT	KIT PALIERS JOINTS D'HUILE DE VILEBREQUIN Jeu		KK01006	KK01006	
KIT REVISIONE POMPA ACQUA	WATER PUMP REPAIR KIT	KIT RÉVISION POMPE À EAU		AA00819		
KIT TAGLIANDO	SERVICE KIT	KIT COUPON			TG00119	TG00104
MASSE CENTRIFUGHE PESO ORIGINALE	ROLLER WEIGHTS Standard weight	MASSELOTTE CENTRIFUGES POIDS D'ORIGINE		9918410	9922390	
MEMBRANA CARBURATORE TIPO ORIGINALE	CARBURETOR DIAPHRAGM OEM	MEMBRANE CARBURATEUR TYPE ORIGINAL				
MEMBRANA CARBURATORE ADATTABILE	CARBURETOR DIAPHRAGM Adaptable	MEMBRANE CARBURATEUR ADAPTABLE				
MOLLE CONTRASTO VARIATORE	REAR VARIATOR SPRING	RESSORTS CONTRASTE VARIATEUR		9926790	9926790	
MOLLA A GAS PER SELIA	SEAT GAS SPRING	RESSORT À GAZ POUR SELLE			9980260	9980260
MOTORINO D'AVVIAMENTO	STARTER ENGINE	DÉMARREUR ÉLECTRIQUE		MA00021		
PIATTELLO PORTATASSELI	VARIATOR SLIDERS	CURSEURS VARIATEUR				
POMPA BENZINA	FUEL PUMP	POMPE À ESSENCE				
PULEGGIA FISSA	FIXED SHEAVE	POULIE FIXE				
REGOLATORE DI TENSIONE	RECTIFIER	RÉGULATEUR DE TENSION				
RUOTA LIBERA Completa	STARTER CLUTCH SET	ROUE LIBRE Complète		RL00012		
RUOTA LIBERA RL + flangia	STARTER CLUTCH + FLANGE	ROUE LIBRE RL + flasque				
RUOTA LIBERA RL nuda	STARTER CLUTCH	ROUE LIBRE RL nue				
RUOTA LIBERA Ingranaggio	STARTER CLUTCH GEAR	ROUE LIBRE Engrenage				
RUOTA LIBERA Flangia	STARTER CLUTCH FLANGE	ROUE LIBRE Flasque				
SERIE DISCHI FRIZIONE	CLUTCH PLATES KIT	JEU DISQUES EMBRAYAGE				
STATORE	STATOR	STATOR				
TASSELLI TRAINO	VARIATOR SLIDERS	CURSEURS VARIATEUR		AA00853	AA00853	AA00853
VARIATORE VARIOTOP TPR	VARIOTOP TPR	VARIOTOP TPR			9926010	

SUZUKI	SUZUKI	SUZUKI	SUZUKI	SUZUKI	SUZUKI	SUZUKI	SUZUKI	SUZUKI	SUZUKI	SUZUKI	SUZUKI
AN BURGMAN L1	AN BURGMAN L2	AN BURGMAN L2	AN BURGMAN L3	AN BURGMAN L3	AN BURGMAN L4	AN BURGMAN L4	AN BURGMAN L5	AN BURGMAN L5	AN BURGMAN L6	AN BURGMAN L6	AN BURGMAN W/X/Y
11-11	12-12	12-12	13-13	13-13	14-14	14-14	15-15	15-15	16-16	16-16	98-00
650cc 4T LC	400cc 4T LC	650cc 4T LC	400cc 4T LC	650cc 4T LC	400cc 4T LC	650cc 4T LC	400cc 4T LC	650cc 4T LC	400cc 4T LC	650cc 4T LC	250cc 4T LC
	FZ00402		FZ00402		FZ00402		FZ00402		FZ00402		
	9927660		9927660		9927660		9927660		9927660		
											9935510
	F007522		F007522		F007522		F007522		F007522		F007510
	FZ00419		FZ00419		FZ00419		FZ00419		FZ00419		FZ00392
											AA00819
TG00119	TG00104	TG00119	TG00104	TG00119	TG00104	TG00119	TG00104	TG00119	TG00104	TG00119	
	9980260		9980260		9980260		9980260		9980260		
											MA00021
											RL00018
	AA00853		AA00853		AA00853		AA00853		AA00853		AA00853
											9923790

MAXI SCOOTER

MAXI SCOOTER

TOP
- performances -



SUZUKI	SUZUKI	SUZUKI	SUZUKI
AN BURGMAN X/K2	AN S-Y	AN T-Y	AN650Z BURGMAN
99-02	95-00	96-00	18-18
400cc 4T LC	125cc 4T AC	150cc 4T AC	650cc 4T LC

IT	EN	FR				
ALBERO A CAMME	CAM SHAFT	ARBRE À CAMES				
ALBERO MOTORE Sel 1/Sel 2	CRANKSHAFT Sel 1/Sel 2	VILEBREQUIN Sél 1/ Sél 2				
CAMPANA FRIZIONE	CLUTCH HOUSING	CLOCHE EMBRAYAGE				
CINGHIA DI TRASMISSIONE Bando	TRANSMISSION BELT Bando	COURROIE DE TRANSMISSION Bando		9935520	9935940	
CINGHIA DI TRASMISSIONE Mitsuboshi	TRANSMISSION BELT Mitsuboshi	COURROIE DE TRANSMISSION Mitsuboshi				
CINGHIA DI TRASMISSIONE Altro	TRANSMISSION BELT Other	COURROIE DE TRANSMISSION Autres				
COLLETTORE ASPIRAZIONE	INLET MANIFOLD	COLLECTEUR ASPIRATION				
COLLETTORE ASPIRAZIONE SX	INLET MANIFOLD LEFT	COLLECTEUR ASPIRATION GAUCHE				
COLLETTORE ASPIRAZIONE DX	INLET MANIFOLD RIGHT	COLLECTEUR ASPIRATION DROITE				
FILTRO OLIO	OIL FILTER	FILTRE À HUILE		F007510	F007522	F007522
FRIZIONE	CLUTCH	EMBAYAGE		FZ00403		
GRUPPO TERMICO Standard	CYLINDER KIT Ø standard	CYLINDRE COMPLET Standard				
GRUPPO TERMICO Maggiorato	CYLINDER KIT BIG BORE	CYLINDRE COMPLET Majoré				
KIT CUSCINETTI PARAOLI DI BANCO Serie	BEARINGS AND OIL SEALS KIT	KIT PALIERS JOINTS D'HUILE DE VILEBREQUIN Jeu		KK01006		
KIT REVISIONE POMPA ACQUA	WATER PUMP REPAIR KIT	KIT RÉVISION POMPE À EAU		AA00819		
KIT TAGLIANDO	SERVICE KIT	KIT COUPON				TG00119
MASSE CENTRIFUGHE PESO ORIGINALE	ROLLER WEIGHTS Standard weight	MASSELOTTE CENTRIFUGES POIDS D'ORIGINE				
MEMBRANA CARBURATORE TIPO ORIGINALE	CARBURETOR DIAPHRAGM OEM	MEMBRANE CARBURATEUR TYPE ORIGINAL				
MEMBRANA CARBURATORE ADATTABILE	CARBURETOR DIAPHRAGM Adaptable	MEMBRANE CARBURATEUR ADAPTABLE				
MOLLE CONTRASTO VARIATORE	REAR VARIATOR SPRING	RESSORTS CONTRASTE VARIATEUR				
MOLLA A GAS PER SELIA	SEAT GAS SPRING	RESSORT À GAZ POUR SELLE				
MOTORINO D'AVVIAMENTO	STARTER ENGINE	DÉMARREUR ÉLECTRIQUE		MA00021		
PIATTELLO PORTATASSELI	VARIATOR SLIDERS	CURSEURS VARIATEUR				
POMPA BENZINA	FUEL PUMP	POMPE À ESSENCE				
PULEGGIA FISSA	FIXED SHEAVE	POULIE FIXE				
REGOLATORE DI TENSIONE	RECTIFIER	RÉGULATEUR DE TENSION				
RUOTA LIBERA Completa	STARTER CLUTCH SET	ROUE LIBRE Complète		RL00012		
RUOTA LIBERA RL + flangia	STARTER CLUTCH + FLANGE	ROUE LIBRE RL + flasque				
RUOTA LIBERA RL nuda	STARTER CLUTCH	ROUE LIBRE RL nue				
RUOTA LIBERA Ingranaggio	STARTER CLUTCH GEAR	ROUE LIBRE Engrenage				
RUOTA LIBERA Flangia	STARTER CLUTCH FLANGE	ROUE LIBRE Flasque				
SERIE DISCHI FRIZIONE	CLUTCH PLATES KIT	JEU DISQUES EMBRAYAGE				
STATORE	STATOR	STATOR				
TASSELLI TRAINO	VARIATOR SLIDERS	CURSEURS VARIATEUR		AA00853		
VARIATORE VARIOTOP TPR	VARIOTOP TPR	VARIOTOP TPR				

MAXI SCOOTER

TOP
- performances -



SUZUKI	SUZUKI	SUZUKI	SUZUKI
UH BURGMAN L4	UH BURGMAN L4	UH BURGMAN L4	UH BURGMAN L6
14-14	14-14	14-14	16-16
125cc 4T LC	125cc 4T LC	200cc 4T LC	125cc 4T LC

IT	EN	FR				
ALBERO A CAMME	CAM SHAFT	ARBRE À CAMES				
ALBERO MOTORE Sel 1/Sel 2	CRANKSHAFT Sel 1/Sel 2	VILEBREQUIN Sél 1/ Sél 2				
CAMPANA FRIZIONE	CLUTCH HOUSING	CLOCHE EMBRAYAGE				
CINGHIA DI TRASMISSIONE Bando	TRANSMISSION BELT Bando	COURROIE DE TRANSMISSION Bando		9927510		9927520
CINGHIA DI TRASMISSIONE Mitsuboshi	TRANSMISSION BELT Mitsuboshi	COURROIE DE TRANSMISSION Mitsuboshi				9927510
CINGHIA DI TRASMISSIONE Altro	TRANSMISSION BELT Other	COURROIE DE TRANSMISSION Autres				
COLLETTORE ASPIRAZIONE	INLET MANIFOLD	COLLECTEUR ASPIRATION				
COLLETTORE ASPIRAZIONE SX	INLET MANIFOLD LEFT	COLLECTEUR ASPIRATION GAUCHE				
COLLETTORE ASPIRAZIONE DX	INLET MANIFOLD RIGHT	COLLECTEUR ASPIRATION DROITE				
FILTRO OLIO	OIL FILTER	FILTRE À HUILE				
FRIZIONE	CLUTCH	EMBAYAGE				
GRUPPO TERMICO Standard	CYLINDER KIT Ø standard	CYLINDRE COMPLET Standard				
GRUPPO TERMICO Maggiorato	CYLINDER KIT BIG BORE	CYLINDRE COMPLET Majoré				
KIT CUSCINETTI PARAOLI DI BANCO Serie	BEARINGS AND OIL SEALS KIT	KIT PALIERS JOINTS D'HUILE DE VILEBREQUIN Jeu				
KIT REVISIONE POMPA ACQUA	WATER PUMP REPAIR KIT	KIT RÉVISION POMPE À EAU				
KIT TAGLIANDO	SERVICE KIT	KIT COUPON			TG00118	
MASSE CENTRIFUGHE PESO ORIGINALE	ROLLER WEIGHTS Standard weight	MASSELOTTE CENTRIFUGES POIDS D'ORIGINE				
MEMBRANA CARBURATORE TIPO ORIGINALE	CARBURETOR DIAPHRAGM OEM	MEMBRANE CARBURATEUR TYPE ORIGINAL				
MEMBRANA CARBURATORE ADATTABILE	CARBURETOR DIAPHRAGM Adaptable	MEMBRANE CARBURATEUR ADAPTABLE				
MOLLE CONTRASTO VARIATORE	REAR VARIATOR SPRING	RESSORTS CONTRASTE VARIATEUR				
MOLLA A GAS PER SELIA	SEAT GAS SPRING	RESSORT À GAZ POUR SELLE				
MOTORINO D'AVVIAMENTO	STARTER ENGINE	DÉMARREUR ÉLECTRIQUE				
PIATTELLO PORTATASSELI	VARIATOR SLIDERS	CURSEURS VARIATEUR				
POMPA BENZINA	FUEL PUMP	POMPE À ESSENCE				
PULEGGIA FISSA	FIXED SHEAVE	POULIE FIXE				
REGOLATORE DI TENSIONE	RECTIFIER	RÉGULATEUR DE TENSION				
RUOTA LIBERA Completa	STARTER CLUTCH SET	ROUE LIBRE Complète				
RUOTA LIBERA RL + flangia	STARTER CLUTCH + FLANGE	ROUE LIBRE RL + flasque				
RUOTA LIBERA RL nuda	STARTER CLUTCH	ROUE LIBRE RL nue				
RUOTA LIBERA Ingranaggio	STARTER CLUTCH GEAR	ROUE LIBRE Engrenage				
RUOTA LIBERA Flangia	STARTER CLUTCH FLANGE	ROUE LIBRE Flasque				
SERIE DISCHI FRIZIONE	CLUTCH PLATES KIT	JEU DISQUES EMBRAYAGE				
STATORE	STATOR	STATOR				
TASSELLI TRAINO	VARIATOR SLIDERS	CURSEURS VARIATEUR				AA00853
VARIATORE VARIOTOP TPR	VARIOTOP TPR	VARIOTOP TPR				

SUZUKI	SUZUKI	SUZUKI	SUZUKI	SUZUKI	SUZUKI	SUZUKI	SUZUKI	SYM	SYM	SYM	SYM
UH BURGMAN L6	UH BURGMAN L7	UH BURGMAN L8	UH BURGMAN L9	UX SIXTEEN K8/L0	UX SIXTEEN K8/L0	UX SIXTEEN L1	UX SIXTEEN L1	ATTILA	ATTILA	CITYCOM	CITYCOM EFI
16-16	17-17	18-18	19-19	08-10	08-10	11-11	11-11	99-00	99-00	08-09	10-11
125cc 4T LC	125cc 4T LC	125cc 4T LC	125cc 4T LC	125cc 4T LC	150cc 4T LC	125cc 4T LC	150cc 4T LC	125cc 4T AC	150cc 4T AC	300cc 4T-4V LC	300cc 4T-4V LC
				FZ00412	FZ00412	FZ00412	FZ00412	FZ00416	FZ00416		
					9935530 9935540		9935530 9935540			9935550	9935550
				F007522	F007522	F007522	F007522				
				FZ00413		FZ00413				FZ00388	
				KK01006	KK01006						
TG00118	TG00118	TG00118	TG00118								
										MA00031	MA00031
				AA00853	AA00853	AA00853	AA00853				
				9923460	9923460						

MAXI SCOOTER

MAXI SCOOTER

TOP
- performances -



SYM	SYM	SYM	SYM
CITYCOM I CBS	CITYCOM I S EURO4	CITYCOM S I CBS	EURO MX
12-12	17-17	15-15	02-02
300cc 4T-4V LC	300cc 4T-4V LC	300cc 4T-4V LC	125cc 4T AC

IT	EN	FR				
ALBERO A CAMME	CAM SHAFT	ARBRE À CAMES				
ALBERO MOTORE Sel 1/Sel 2	CRANKSHAFT Sel 1/Sel 2	VILEBREQUIN Sél 1/ Sél 2				
CAMPANA FRIZIONE	CLUTCH HOUSING	CLOCHE EMBRAYAGE				
CINGHIA DI TRASMISSIONE Bando	TRANSMISSION BELT Bando	COURROIE DE TRANSMISSION Bando				
CINGHIA DI TRASMISSIONE Mitsuboshi	TRANSMISSION BELT Mitsuboshi	COURROIE DE TRANSMISSION Mitsuboshi				
CINGHIA DI TRASMISSIONE Altro	TRANSMISSION BELT Other	COURROIE DE TRANSMISSION Autres				
COLLETTORE ASPIRAZIONE	INLET MANIFOLD	COLLECTEUR ASPIRATION				
COLLETTORE ASPIRAZIONE SX	INLET MANIFOLD LEFT	COLLECTEUR ASPIRATION GAUCHE				
COLLETTORE ASPIRAZIONE DX	INLET MANIFOLD RIGHT	COLLECTEUR ASPIRATION DROITE				
FILTRO OLIO	OIL FILTER	FILTRE À HUILE				
FRIZIONE	CLUTCH	EMBAYAGE				
GRUPPO TERMICO Standard	CYLINDER KIT Ø standard	CYLINDRE COMPLET Standard				
GRUPPO TERMICO Maggiorato	CYLINDER KIT BIG BORE	CYLINDRE COMPLET Majoré				
KIT CUSCINETTI PARAOLI DI BANCO Serie	BEARINGS AND OIL SEALS KIT	KIT PALIERS JOINTS D'HUILE DE VILEBREQUIN Jeu				
KIT REVISIONE POMPA ACQUA	WATER PUMP REPAIR KIT	KIT RÉVISION POMPE À EAU				
KIT TAGLIANDO	SERVICE KIT	KIT COUPON				
MASSE CENTRIFUGHE PESO ORIGINALE	ROLLER WEIGHTS Standard weight	MASSELOTTE CENTRIFUGES POIDS D'ORIGINE				
MEMBRANA CARBURATORE TIPO ORIGINALE	CARBURETOR DIAPHRAGM OEM	MEMBRANE CARBURATEUR TYPE ORIGINAL				
MEMBRANA CARBURATORE ADATTABILE	CARBURETOR DIAPHRAGM Adaptable	MEMBRANE CARBURATEUR ADAPTABLE				
MOLLE CONTRASTO VARIATORE	REAR VARIATOR SPRING	RESSORTS CONTRASTE VARIATEUR				
MOLLA A GAS PER SELIA	SEAT GAS SPRING	RESSORT À GAZ POUR SELLE				
MOTORINO D'AVVIAMENTO	STARTER ENGINE	DÉMARREUR ÉLECTRIQUE	MA00031	MA00031	MA00031	MA00026
PIATTELLO PORTATASSELI	VARIATOR SLIDERS	CURSEURS VARIATEUR				
POMPA BENZINA	FUEL PUMP	POMPE À ESSENCE				
PULEGGIA FISSA	FIXED SHEAVE	POULIE FIXE				
REGOLATORE DI TENSIONE	RECTIFIER	RÉGULATEUR DE TENSION				
RUOTA LIBERA Completa	STARTER CLUTCH SET	ROUE LIBRE Complète				
RUOTA LIBERA RL + flangia	STARTER CLUTCH + FLANGE	ROUE LIBRE RL + flasque				
RUOTA LIBERA RL nuda	STARTER CLUTCH	ROUE LIBRE RL nue				
RUOTA LIBERA Ingranaggio	STARTER CLUTCH GEAR	ROUE LIBRE Engrenage				
RUOTA LIBERA Flangia	STARTER CLUTCH FLANGE	ROUE LIBRE Flasque				
SERIE DISCHI FRIZIONE	CLUTCH PLATES KIT	JEU DISQUES EMBRAYAGE				
STATORE	STATOR	STATOR				
TASSELLI TRAINO	VARIATOR SLIDERS	CURSEURS VARIATEUR				
VARIATORE VARIOTOP TPR	VARIOTOP TPR	VARIOTOP TPR				

SYM	SYM	SYM	SYM	SYM	SYM	SYM	SYM	SYM	SYM	SYM	SYM
EURO MX	EURO MX EU2	EURO MX EU2	FIDDLE II	FIDDLE II	FIDDLE II	FIDDLE II	GTS	GTS JOYMAX	HD EU2	HD EU2	HD EU3
02-02	03-04	03-04	08-08	09-09	10-13	10-10	07-08	06-07	03-04	03-04	07-08
150cc 4T AC	125cc 4T AC	150cc 4T AC	125cc 4T AC	125cc 4T AC	125cc 4T AC	150cc 4T AC	250cc 4T-4V LC	125cc 4T LC	125cc 4T-4V LC	200cc 4T-4V LC	125cc 4T-4V LC
					IM07069						
FZ00416	FZ00416	FZ00416	FZ00416	FZ00416	FZ00416	FZ00416		FZ00416	FZ00416		FZ00416
			9926420	9926420			9925850			9925860	
							9935790				
MA00026	MA00026	MA00026	MA00007	MA00007			MA00031	MA00004			MA00004
									ST00029	ST00029	ST00029

MAXI SCOOTER

TOP
- performances -



SYM	SYM	SYM	SYM
HD EU3 I	HD EVO	HD EVO EU2	HD EVO EU3
07-07	05-06	05-06	07-08
200cc 4T-4V LC	125cc 4T-4V LC	200cc 4T-4V LC	125cc 4T-4V LC

IT	EN	FR				
ALBERO A CAMME	CAM SHAFT	ARBRE À CAMES				
ALBERO MOTORE Sel 1/Sel 2	CRANKSHAFT Sel 1/Sel 2	VILEBREQUIN Sél 1/ Sél 2				
CAMPANA FRIZIONE	CLUTCH HOUSING	CLOCHE EMBRAYAGE			FZ00416	FZ00416
CINGHIA DI TRASMISSIONE Bando	TRANSMISSION BELT Bando	COURROIE DE TRANSMISSION Bando		9925860		9925860
CINGHIA DI TRASMISSIONE Mitsuboshi	TRANSMISSION BELT Mitsuboshi	COURROIE DE TRANSMISSION Mitsuboshi				
CINGHIA DI TRASMISSIONE Altro	TRANSMISSION BELT Other	COURROIE DE TRANSMISSION Autres				
COLLETTORE ASPIRAZIONE	INLET MANIFOLD	COLLECTEUR ASPIRATION				
COLLETTORE ASPIRAZIONE SX	INLET MANIFOLD LEFT	COLLECTEUR ASPIRATION GAUCHE				
COLLETTORE ASPIRAZIONE DX	INLET MANIFOLD RIGHT	COLLECTEUR ASPIRATION DROITE				
FILTRO OLIO	OIL FILTER	FILTRE À HUILE				
FRIZIONE	CLUTCH	EMBRAYAGE				
GRUPPO TERMICO Standard	CYLINDER KIT Ø standard	CYLINDRE COMPLET Standard			9936200	9936200
GRUPPO TERMICO Maggiorato	CYLINDER KIT BIG BORE	CYLINDRE COMPLET Majoré				
KIT CUSCINETTI PARAOLI DI BANCO Serie	BEARINGS AND OIL SEALS KIT	KIT PALIERS JOINTS D'HUILE DE VILEBREQUIN Jeu				
KIT REVISIONE POMPA ACQUA	WATER PUMP REPAIR KIT	KIT RÉVISION POMPE À EAU				
KIT TAGLIANDO	SERVICE KIT	KIT COUPON				
MASSE CENTRIFUGHE PESO ORIGINALE	ROLLER WEIGHTS Standard weight	MASSELOTTE CENTRIFUGES POIDS D'ORIGINE				
MEMBRANA CARBURATORE TIPO ORIGINALE	CARBURETOR DIAPHRAGM OEM	MEMBRANE CARBURATEUR TYPE ORIGINAL				
MEMBRANA CARBURATORE ADATTABILE	CARBURETOR DIAPHRAGM Adaptable	MEMBRANE CARBURATEUR ADAPTABLE				
MOLLE CONTRASTO VARIATORE	REAR VARIATOR SPRING	RESSORTS CONTRASTE VARIATEUR				
MOLLA A GAS PER SELIA	SEAT GAS SPRING	RESSORT À GAZ POUR SELLE				
MOTORINO D'AVVIAMENTO	STARTER ENGINE	DÉMARREUR ÉLECTRIQUE			MA00004	MA00004
PIATTELLO PORTATASSELI	VARIATOR SLIDERS	CURSEURS VARIATEUR				
POMPA BENZINA	FUEL PUMP	POMPE À ESSENCE				
PULEGGIA FISSA	FIXED SHEAVE	POULIE FIXE				
REGOLATORE DI TENSIONE	RECTIFIER	RÉGULATEUR DE TENSION				
RUOTA LIBERA Completa	STARTER CLUTCH SET	ROUE LIBRE Complète				
RUOTA LIBERA RL + flangia	STARTER CLUTCH + FLANGE	ROUE LIBRE RL + flasque				
RUOTA LIBERA RL nuda	STARTER CLUTCH	ROUE LIBRE RL nue				
RUOTA LIBERA Ingranaggio	STARTER CLUTCH GEAR	ROUE LIBRE Engrenage				
RUOTA LIBERA Flangia	STARTER CLUTCH FLANGE	ROUE LIBRE Flasque				
SERIE DISCHI FRIZIONE	CLUTCH PLATES KIT	JEU DISQUES EMBRAYAGE				
STATORE	STATOR	STATOR			ST00029	ST00029
TASSELLI TRAINO	VARIATOR SLIDERS	CURSEURS VARIATEUR				
VARIATORE VARIOTOP TPR	VARIOTOP TPR	VARIOTOP TPR				

SYM	SYM	SYM	SYM	SYM	SYM	SYM	SYM	SYM	SYM	SYM	SYM
HD EVO EU3	HD EVO EU3 I	HD EVO I EU3	HD EVO I TAM-BURO EU3	HD EVO TAM-BURO EU3	HD2	HD2	HD2 I	JET 4	JET V	JOYMAX	JOYMAX EU3 I
10-11	07-07	10-10	08-09	08-09	11-11	14-14	11-11	09-10	11-11	05-07	07-08
125cc 4T-4V LC	200cc 4T-4V LC	200cc 4T-4V LC	200cc 4T-4V LC	125cc 4T-4V LC	125cc 4T-4V LC	125cc 4T-4V LC	200cc 4T-4V LC	125cc 4T AC	125cc 4T AC	250cc 4T-4V LC	250cc 4T-4V LC
								IM07069			
FZ00416				FZ00416	FZ00416			FZ00416	FZ00416		
	9925860	9925860	9925860				9925860			9925850	9925850
										9935790	9935790
								FZ00417		FZ00388	
9936200				9936200	9936200	9936200					
								9936000			
ST00029				ST00029	ST00029	ST00029					

MAXI SCOOTER

MAXI SCOOTER

TOP
- performances -



SYM	SYM	SYM	SYM
JOYMAX EVO	JOYMAX EVO I	JOYMAX I	JOYMAX I
09-09	10-10	12-12	14-14
300cc 4T-4V LC	300cc 4T-4V LC	300cc 4T-4V LC	300cc 4T-4V LC

IT	EN	FR					
ALBERO A CAMME	CAM SHAFT	ARBRE À CAMES					
ALBERO MOTORE Sel 1/Sel 2	CRANKSHAFT Sel 1/Sel 2	VILEBREQUIN Sél 1/ Sél 2					
CAMPANA FRIZIONE	CLUTCH HOUSING	CLOCHE EMBRAYAGE					
CINGHIA DI TRASMISSIONE Bando	TRANSMISSION BELT Bando	COURROIE DE TRANSMISSION Bando					
CINGHIA DI TRASMISSIONE Mitsuboshi	TRANSMISSION BELT Mitsuboshi	COURROIE DE TRANSMISSION Mitsuboshi		9935560	9935560		
CINGHIA DI TRASMISSIONE Altro	TRANSMISSION BELT Other	COURROIE DE TRANSMISSION Autres					
COLLETTORE ASPIRAZIONE	INLET MANIFOLD	COLLECTEUR ASPIRATION					
COLLETTORE ASPIRAZIONE SX	INLET MANIFOLD LEFT	COLLECTEUR ASPIRATION GAUCHE					
COLLETTORE ASPIRAZIONE DX	INLET MANIFOLD RIGHT	COLLECTEUR ASPIRATION DROITE					
FILTRO OLIO	OIL FILTER	FILTRE À HUILE					
FRIZIONE	CLUTCH	EMBAYAGE		FZ00388			
GRUPPO TERMICO Standard	CYLINDER KIT Ø standard	CYLINDRE COMPLET Standard					
GRUPPO TERMICO Maggiorato	CYLINDER KIT BIG BORE	CYLINDRE COMPLET Majoré					
KIT CUSCINETTI PARAOLI DI BANCO Serie	BEARINGS AND OIL SEALS KIT	KIT PALIERS JOINTS D'HUILE DE VILEBREQUIN Jeu					
KIT REVISIONE POMPA ACQUA	WATER PUMP REPAIR KIT	KIT RÉVISION POMPE À EAU					
KIT TAGLIANDO	SERVICE KIT	KIT COUPON					
MASSE CENTRIFUGHE PESO ORIGINALE	ROLLER WEIGHTS Standard weight	MASSELOTTE CENTRIFUGES POIDS D'ORIGINE					
MEMBRANA CARBURATORE TIPO ORIGINALE	CARBURETOR DIAPHRAGM OEM	MEMBRANE CARBURATEUR TYPE ORIGINAL					
MEMBRANA CARBURATORE ADATTABILE	CARBURETOR DIAPHRAGM Adaptable	MEMBRANE CARBURATEUR ADAPTABLE					
MOLLE CONTRASTO VARIATORE	REAR VARIATOR SPRING	RESSORTS CONTRASTE VARIATEUR					
MOLLA A GAS PER SELIA	SEAT GAS SPRING	RESSORT À GAZ POUR SELLE					
MOTORINO D'AVVIAMENTO	STARTER ENGINE	DÉMARREUR ÉLECTRIQUE		MA00031	MA00031	MA00031	
PIATTELLO PORTATASSELI	VARIATOR SLIDERS	CURSEURS VARIATEUR					
POMPA BENZINA	FUEL PUMP	POMPE À ESSENCE					
PULEGGIA FISSA	FIXED SHEAVE	POULIE FIXE					
REGOLATORE DI TENSIONE	RECTIFIER	RÉGULATEUR DE TENSION					
RUOTA LIBERA Completa	STARTER CLUTCH SET	ROUE LIBRE Complète					
RUOTA LIBERA RL + flangia	STARTER CLUTCH + FLANGE	ROUE LIBRE RL + flasque					
RUOTA LIBERA RL nuda	STARTER CLUTCH	ROUE LIBRE RL nue					
RUOTA LIBERA Ingranaggio	STARTER CLUTCH GEAR	ROUE LIBRE Engrenage					
RUOTA LIBERA Flangia	STARTER CLUTCH FLANGE	ROUE LIBRE Flasque					
SERIE DISCHI FRIZIONE	CLUTCH PLATES KIT	JEU DISQUES EMBRAYAGE					
STATORE	STATOR	STATOR					
TASSELLI TRAINO	VARIATOR SLIDERS	CURSEURS VARIATEUR					
VARIATORE VARIOTOP TPR	VARIOTOP TPR	VARIOTOP TPR					

SYM	SYM	SYM	SYM	SYM	SYM	SYM	SYM	SYM	SYM	SYM	SYM
JOYMAX I ABS	JOYMAX I ABS	JOYRIDE	JOYRIDE	JOYRIDE	JOYRIDE EU2	JOYRIDE EU2	JOYRIDE EU2	JOYRIDE EU2	JOYRIDE EU3	JOYRIDE EVO	JOYRIDE EVO
13-13	14-14	01-02	01-02	03-03	03-04	05-06	03-04	05-06	07-07	09-10	10-10
300cc 4T-4V LC	300cc 4T-4V LC	125cc 4T-4V LC	150cc 4T-4V LC	200cc 4T-4V LC	125cc 4T-4V LC	125cc 4T-4V LC	200cc 4T-4V LC	200cc 4T-4V LC	125cc 4T-4V LC	125cc 4T-4V LC	125cc 4T-4V LC
						FZ00416			FZ00416	FZ00416	FZ00416
		9936200			9936200	9936200			9936200	9936200	9936200
MA00031	MA00031	MA00004	MA00004			MA00004			MA00004	MA00004	MA00004
		ST00029	ST00029	ST00029	ST00029	ST00029	ST00029	ST00029	ST00029	ST00029	ST00029

MAXI SCOOTER

MAXI SCOOTER

TOP
- performances -



SYM	SYM	SYM	SYM
JOYRIDE EVO	JOYRIDE EVO	MEGALO	NEW DUKE
13-13	14-14	06-07	00-01
125cc 4T-4V LC	125cc 4T-4V LC	125cc 4T AC	125cc 4T AC

IT	EN	FR				
ALBERO A CAMME	CAM SHAFT	ARBRE À CAMES				
ALBERO MOTORE Sel 1/Sel 2	CRANKSHAFT Sel 1/Sel 2	VILEBREQUIN Sél 1/ Sél 2				
CAMPANA FRIZIONE	CLUTCH HOUSING	CLOCHE EMBRAYAGE				
CINGHIA DI TRASMISSIONE Bando	TRANSMISSION BELT Bando	COURROIE DE TRANSMISSION Bando				
CINGHIA DI TRASMISSIONE Mitsuboshi	TRANSMISSION BELT Mitsuboshi	COURROIE DE TRANSMISSION Mitsuboshi				
CINGHIA DI TRASMISSIONE Altro	TRANSMISSION BELT Other	COURROIE DE TRANSMISSION Autres				
COLLETTORE ASPIRAZIONE	INLET MANIFOLD	COLLECTEUR ASPIRATION				
COLLETTORE ASPIRAZIONE SX	INLET MANIFOLD LEFT	COLLECTEUR ASPIRATION GAUCHE				
COLLETTORE ASPIRAZIONE DX	INLET MANIFOLD RIGHT	COLLECTEUR ASPIRATION DROITE				
FILTRO OLIO	OIL FILTER	FILTRE À HUILE				
FRIZIONE	CLUTCH	EMBRAYAGE				
GRUPPO TERMICO Standard	CYLINDER KIT Ø standard	CYLINDRE COMPLET Standard	9936200	9936200		
GRUPPO TERMICO Maggiorato	CYLINDER KIT BIG BORE	CYLINDRE COMPLET Majoré				
KIT CUSCINETTI PARAOLI DI BANCO Serie	BEARINGS AND OIL SEALS KIT	KIT PALIERS JOINTS D'HUILE DE VILEBREQUIN Jeu				
KIT REVISIONE POMPA ACQUA	WATER PUMP REPAIR KIT	KIT RÉVISION POMPE À EAU				
KIT TAGLIANDO	SERVICE KIT	KIT COUPON				
MASSE CENTRIFUGHE PESO ORIGINALE	ROLLER WEIGHTS Standard weight	MASSELOTTE CENTRIFUGES POIDS D'ORIGINE				
MEMBRANA CARBURATORE TIPO ORIGINALE	CARBURETOR DIAPHRAGM OEM	MEMBRANE CARBURATEUR TYPE ORIGINAL				
MEMBRANA CARBURATORE ADATTABILE	CARBURETOR DIAPHRAGM Adaptable	MEMBRANE CARBURATEUR ADAPTABLE				
MOLLE CONTRASTO VARIATORE	REAR VARIATOR SPRING	RESSORTS CONTRASTE VARIATEUR				
MOLLA A GAS PER SELIA	SEAT GAS SPRING	RESSORT À GAZ POUR SELLE				
MOTORINO D'AVVIAMENTO	STARTER ENGINE	DÉMARREUR ÉLECTRIQUE				
PIATTELLO PORTATASSELI	VARIATOR SLIDERS	CURSEURS VARIATEUR				
POMPA BENZINA	FUEL PUMP	POMPE À ESSENCE				
PULEGGIA FISSA	FIXED SHEAVE	POULIE FIXE				
REGOLATORE DI TENSIONE	RECTIFIER	RÉGULATEUR DE TENSION				
RUOTA LIBERA Completa	STARTER CLUTCH SET	ROUE LIBRE Complète				
RUOTA LIBERA RL + flangia	STARTER CLUTCH + FLANGE	ROUE LIBRE RL + flasque				
RUOTA LIBERA RL nuda	STARTER CLUTCH	ROUE LIBRE RL nue				
RUOTA LIBERA Ingranaggio	STARTER CLUTCH GEAR	ROUE LIBRE Engrenage				
RUOTA LIBERA Flangia	STARTER CLUTCH FLANGE	ROUE LIBRE Flasque				
SERIE DISCHI FRIZIONE	CLUTCH PLATES KIT	JEU DISQUES EMBRAYAGE				
STATORE	STATOR	STATOR	ST00029	ST00029		
TASSELLI TRAINO	VARIATOR SLIDERS	CURSEURS VARIATEUR				
VARIATORE VARIOTOP TPR	VARIOTOP TPR	VARIOTOP TPR				

MAXI SCOOTER

TOP
- performances -



SYM	SYM	SYM	SYM
SYMPHONY S	SYMPHONY SR	SYMPHONY SR	SYMPHONY SR
13-14	10-10	12-14	10-10
150cc 4T AC	125cc 4T AC	125cc 4T AC	150cc 4T AC

IT	EN	FR				
ALBERO A CAMME	CAM SHAFT	ARBRE À CAMES				
ALBERO MOTORE Sel 1/Sel 2	CRANKSHAFT Sel 1/Sel 2	VILEBREQUIN Sel 1/ Sel 2			IM07069	
CAMPANA FRIZIONE	CLUTCH HOUSING	CLOCHE EMBRAYAGE			FZ00416	FZ00416
CINGHIA DI TRASMISSIONE Bando	TRANSMISSION BELT Bando	COURROIE DE TRANSMISSION Bando		9931680	9931680	9931680
CINGHIA DI TRASMISSIONE Mitsuboshi	TRANSMISSION BELT Mitsuboshi	COURROIE DE TRANSMISSION Mitsuboshi				
CINGHIA DI TRASMISSIONE Altro	TRANSMISSION BELT Other	COURROIE DE TRANSMISSION Autres				
COLLETTORE ASPIRAZIONE	INLET MANIFOLD	COLLECTEUR ASPIRATION				
COLLETTORE ASPIRAZIONE SX	INLET MANIFOLD LEFT	COLLECTEUR ASPIRATION GAUCHE				
COLLETTORE ASPIRAZIONE DX	INLET MANIFOLD RIGHT	COLLECTEUR ASPIRATION DROITE				
FILTRO OLIO	OIL FILTER	FILTRE À HUILE				
FRIZIONE	CLUTCH	EMBRAYAGE			FZ00417	FZ00417
GRUPPO TERMICO Standard	CYLINDER KIT Ø standard	CYLINDRE COMPLET Standard				
GRUPPO TERMICO Maggiorato	CYLINDER KIT BIG BORE	CYLINDRE COMPLET Majoré			9936000	9936000
KIT CUSCINETTI PARAOLI DI BANCO Serie	BEARINGS AND OIL SEALS KIT	KIT PALIERS JOINTS D'HUILE DE VILEBREQUIN Jeu				
KIT REVISIONE POMPA ACQUA	WATER PUMP REPAIR KIT	KIT RÉVISION POMPE À EAU				
KIT TAGLIANDO	SERVICE KIT	KIT COUPON				
MASSE CENTRIFUGHE PESO ORIGINALE	ROLLER WEIGHTS Standard weight	MASSELOTTE CENTRIFUGES POIDS D'ORIGINE				
MEMBRANA CARBURATORE TIPO ORIGINALE	CARBURETOR DIAPHRAGM OEM	MEMBRANE CARBURATEUR TYPE ORIGINAL				
MEMBRANA CARBURATORE ADATTABILE	CARBURETOR DIAPHRAGM Adaptable	MEMBRANE CARBURATEUR ADAPTABLE				
MOLLE CONTRASTO VARIATORE	REAR VARIATOR SPRING	RESSORTS CONTRASTE VARIATEUR				
MOLLA A GAS PER SELIA	SEAT GAS SPRING	RESSORT À GAZ POUR SELLE				
MOTORINO D'AVVIAMENTO	STARTER ENGINE	DÉMARREUR ÉLECTRIQUE			MA00026	MA00026
PIATTELLO PORTATASSELI	VARIATOR SLIDERS	CURSEURS VARIATEUR				
POMPA BENZINA	FUEL PUMP	POMPE À ESSENCE				
PULEGGIA FISSA	FIXED SHEAVE	POULIE FIXE				
REGOLATORE DI TENSIONE	RECTIFIER	RÉGULATEUR DE TENSION				
RUOTA LIBERA Completa	STARTER CLUTCH SET	ROUE LIBRE Complète				
RUOTA LIBERA RL + flangia	STARTER CLUTCH + FLANGE	ROUE LIBRE RL + flasque				
RUOTA LIBERA RL nuda	STARTER CLUTCH	ROUE LIBRE RL nue				
RUOTA LIBERA Ingranaggio	STARTER CLUTCH GEAR	ROUE LIBRE Engrenage				
RUOTA LIBERA Flangia	STARTER CLUTCH FLANGE	ROUE LIBRE Flasque				
SERIE DISCHI FRIZIONE	CLUTCH PLATES KIT	JEU DISQUES EMBRAYAGE				
STATORE	STATOR	STATOR				
TASSELLI TRAINO	VARIATOR SLIDERS	CURSEURS VARIATEUR				
VARIATORE VARIOTOP TPR	VARIOTOP TPR	VARIOTOP TPR				

MAXI SCOOTER

TOP
- performances -



YAMAHA	YAMAHA	YAMAHA	YAMAHA
MAJESTY	MAJESTY	MAJESTY	MAJESTY
98-00	00-00	96-98	00-01
125cc 4T LC	150cc 4T LC	250cc 4T LC	250cc 4T LC
Minarelli YP	Minarelli YP	Yamaha YP	Yamaha YP

IT	EN	FR				
ALBERO A CAMME	CAM SHAFT	ARBRE À CAMES				
ALBERO MOTORE Sel 1/Sel 2	CRANKSHAFT Sel 1/Sel 2	VILEBREQUIN Sél 1/ Sél 2		IM07045		IM07054
CAMPANA FRIZIONE	CLUTCH HOUSING	CLOCHE EMBRAYAGE				FZ00397
CINGHIA DI TRASMISSIONE Bando	TRANSMISSION BELT Bando	COURROIE DE TRANSMISSION Bando		9915380	9915380	9915800
CINGHIA DI TRASMISSIONE Mitsuboshi	TRANSMISSION BELT Mitsuboshi	COURROIE DE TRANSMISSION Mitsuboshi		9935700	9935700	9935710
CINGHIA DI TRASMISSIONE Altro	TRANSMISSION BELT Other	COURROIE DE TRANSMISSION Autres				
COLLETTORE ASPIRAZIONE	INLET MANIFOLD	COLLECTEUR ASPIRATION		CT00730	CT00730	
COLLETTORE ASPIRAZIONE SX	INLET MANIFOLD LEFT	COLLECTEUR ASPIRATION GAUCHE				
COLLETTORE ASPIRAZIONE DX	INLET MANIFOLD RIGHT	COLLECTEUR ASPIRATION DROITE				
FILTRO OLIO	OIL FILTER	FILTRE À HUILE				
FRIZIONE	CLUTCH	EMBAYAGE		FZ00371	FZ00401	FZ00401
GRUPPO TERMICO Standard	CYLINDER KIT Ø standard	CYLINDRE COMPLET Standard				9926850
GRUPPO TERMICO Maggiorato	CYLINDER KIT BIG BORE	CYLINDRE COMPLET Majoré		9929380	9929380	
KIT CUSCINETTI PARAOLI DI BANCO Serie	BEARINGS AND OIL SEALS KIT	KIT PALIERS JOINTS D'HUILE DE VILEBREQUIN Jeu		KK01010	KK01010	KK01007
KIT REVISIONE POMPA ACQUA	WATER PUMP REPAIR KIT	KIT RÉVISION POMPE À EAU		AA00805	AA00805	AA00806
KIT TAGLIANDO	SERVICE KIT	KIT COUPON				
MASSE CENTRIFUGHE PESO ORIGINALE	ROLLER WEIGHTS Standard weight	MASSELOTTE CENTRIFUGES POIDS D'ORIGINE		9915270		9918020
MEMBRANA CARBURATORE TIPO ORIGINALE	CARBURETOR DIAPHRAGM OEM	MEMBRANE CARBURATEUR TYPE ORIGINAL				MC12001
MEMBRANA CARBURATORE ADATTABILE	CARBURETOR DIAPHRAGM Adaptable	MEMBRANE CARBURATEUR ADAPTABLE		MC12100	MC12100	MC12101
MOLLE CONTRASTO VARIATORE	REAR VARIATOR SPRING	RESSORTS CONTRASTE VARIATEUR		9929170	9929170	9929870
MOLLA A GAS PER SELIA	SEAT GAS SPRING	RESSORT À GAZ POUR SELLE				
MOTORINO D'AVVIAMENTO	STARTER ENGINE	DÉMARREUR ÉLECTRIQUE		MA00017	MA00017	MA00010
PIATTELLO PORTATASSELI	VARIATOR SLIDERS	CURSEURS VARIATEUR				PL04066
POMPA BENZINA	FUEL PUMP	POMPE À ESSENCE				
PULEGGIA FISSA	FIXED SHEAVE	POULIE FIXE				PL04075
REGOLATORE DI TENSIONE	RECTIFIER	RÉGULATEUR DE TENSION		RE00020	RE00020	
RUOTA LIBERA Completa	STARTER CLUTCH SET	ROUE LIBRE Complète				
RUOTA LIBERA RL + flangia	STARTER CLUTCH + FLANGE	ROUE LIBRE RL + flasque		RL00002	RL00002	RL00010
RUOTA LIBERA RL nuda	STARTER CLUTCH	ROUE LIBRE RL nue				
RUOTA LIBERA Ingranaggio	STARTER CLUTCH GEAR	ROUE LIBRE Engrenage				RL00011
RUOTA LIBERA Flangia	STARTER CLUTCH FLANGE	ROUE LIBRE Flasque				
SERIE DISCHI FRIZIONE	CLUTCH PLATES KIT	JEU DISQUES EMBRAYAGE				
STATORE	STATOR	STATOR		ST00002	ST00002	
TASSELLI TRAINO	VARIATOR SLIDERS	CURSEURS VARIATEUR				
VARIATORE VARIOTOP TPR	VARIOTOP TPR	VARIOTOP TPR		9923550	9923550	9931790

YAMAHA	YAMAHA	YAMAHA	YAMAHA	YAMAHA	YAMAHA	YAMAHA	YAMAHA	YAMAHA	YAMAHA	YAMAHA	YAMAHA
MAJESTY	MAJESTY	MAJESTY	MAJESTY	MAJESTY	MAJESTY (5NR1)	MAJESTY (5NR8)	MAJESTY (5NS1)	MAJESTY (5NS6)	MAJESTY ABS	MAJESTY ABS	MAJESTY ABS
02-03	04-05	06-06	07-08	09-11	01-01	02-02	01-01	02-02	03-03	07-07	08-08
250cc 4T LC	400cc 4T LC	400cc 4T LC	400cc 4T LC	400cc 4T LC	125cc 4T LC	125cc 4T LC	150cc 4T LC	150cc 4T LC	250cc 4T LC	400cc 4T LC	400cc 4T LC
Yamaha YP	5RU	5RU	5RU	34B	Minarelli YP	Minarelli YP	Minarelli YP	Minarelli YP	Yamaha YP	5RU	5RU
IM07054					IM07045	IM07045			IM07054		
FZ00397									FZ00397		
9915800	9927530	9927530			9915380	9915380	9915380	9915380	9915800		
9935710			9935580	9935610	9935700	9935700	9935700	9935700	9935710	9935580	9935580
					CT00730	CT00730	CT00730	CT00730			
	F007521	F007521	F007521	F007521						F007521	F007521
FZ00388	FZ00394	FZ00394	FZ00394	FZ00394	FZ00371	FZ00371	FZ00401	FZ00401	FZ00388	FZ00394	FZ00394
9926850									9926850		
					9929380	9929380	9929380	9929380			
KK01007					KK01010	KK01010	KK01010	KK01010	KK01007		
AA00806	AA00818	AA00818	AA00818		AA00805	AA00805	AA00805	AA00805	AA00806	AA00818	AA00818
9918020	9922150	9922150	9922150	9922230	9915270	9915270			9918020	9922150	9922150
MC12001									MC12001		
MC12101					MC12100	MC12100	MC12100	MC12100	MC12101		
9929870					9929170	9929170	9929170	9929170	9929870		
	9980210	9980210	9980210	9980210						9980210	9980210
MA00010	MA00010	MA00010	MA00010	MA00010	MA00017	MA00017	MA00017	MA00017	MA00010	MA00010	MA00010
PL04066									PL04066		
PL04075									PL04075		
RE00022	RE00022	RE00022	RE00022	RE00022	RE00020	RE00030	RE00020	RE00030	RE00022	RE00022	RE00022
RL00010	RL00019	RL00019	RL00019	RL00019	RL00002	RL00002	RL00002	RL00002	RL00010	RL00019	RL00019
RL00011	RL00020	RL00020	RL00020	RL00020					RL00011	RL00020	RL00020
	ST00022	ST00022	ST00022	ST00022	ST00002	ST00002	ST00002	ST00002		ST00022	ST00022
9931790	9923330	9923330	9923330	9930360	9923550	9923550	9923550	9923550	9931790	9923330	9923330

MAXI SCOOTER

MAXI SCOOTER

TOP
- performances -



YAMAHA	YAMAHA	YAMAHA	YAMAHA
MAJESTY ABS	MAJESTY DX	MAJESTY DX	MAJESTY E
09-11	98-98	99-99	03-05
400cc 4T LC	250cc 4T LC	250cc 4T LC	125cc 4T LC
34B	Yamaha YP	Yamaha YP	Minarelli YP

IT	EN	FR				
ALBERO A CAMME	CAM SHAFT	ARBRE À CAMES				
ALBERO MOTORE Sel 1/Sel 2	CRANKSHAFT Sel 1/Sel 2	VILEBREQUIN Sél 1/ Sél 2		IM07054	IM07054	IM07045
CAMPANA FRIZIONE	CLUTCH HOUSING	CLOCHE EMBRAYAGE				
CINGHIA DI TRASMISSIONE Bando	TRANSMISSION BELT Bando	COURROIE DE TRANSMISSION Bando		9915800	9915800	9915380
CINGHIA DI TRASMISSIONE Mitsuboshi	TRANSMISSION BELT Mitsuboshi	COURROIE DE TRANSMISSION Mitsuboshi		9935610	9935710	9935700
CINGHIA DI TRASMISSIONE Altro	TRANSMISSION BELT Other	COURROIE DE TRANSMISSION Autres				
COLLETTORE ASPIRAZIONE	INLET MANIFOLD	COLLECTEUR ASPIRATION				CT00729
COLLETTORE ASPIRAZIONE SX	INLET MANIFOLD LEFT	COLLECTEUR ASPIRATION GAUCHE				
COLLETTORE ASPIRAZIONE DX	INLET MANIFOLD RIGHT	COLLECTEUR ASPIRATION DROITE				
FILTRO OLIO	OIL FILTER	FILTRE À HUILE		F007521		
FRIZIONE	CLUTCH	EMBAYAGE		FZ00394	FZ00401	FZ00401
GRUPPO TERMICO Standard	CYLINDER KIT Ø standard	CYLINDRE COMPLET Standard		9926850	9926850	
GRUPPO TERMICO Maggiorato	CYLINDER KIT BIG BORE	CYLINDRE COMPLET Majoré				9929380
KIT CUSCINETTI PARAOLI DI BANCO Serie	BEARINGS AND OIL SEALS KIT	KIT PALIERS JOINTS D'HUILE DE VILEBREQUIN Jeu			KK01007	KK01007
KIT REVISIONE POMPA ACQUA	WATER PUMP REPAIR KIT	KIT RÉVISION POMPE À EAU			AA00806	AA00806
KIT TAGLIANDO	SERVICE KIT	KIT COUPON				
MASSE CENTRIFUGHE PESO ORIGINALE	ROLLER WEIGHTS Standard weight	MASSELOTES CENTRIFUGES POIDS D'ORIGINE		9922230	9918020	9918020
MEMBRANA CARBURATORE TIPO ORIGINALE	CARBURETOR DIAPHRAGM OEM	MEMBRANE CARBURATEUR TYPE ORIGINAL			MC12001	MC12001
MEMBRANA CARBURATORE ADATTABILE	CARBURETOR DIAPHRAGM Adaptable	MEMBRANE CARBURATEUR ADAPTABLE			MC12101	MC12101
MOLLE CONTRASTO VARIATORE	REAR VARIATOR SPRING	RESSORTS CONTRASTE VARIATEUR		9929870	9929870	9929170
MOLLA A GAS PER SELIA	SEAT GAS SPRING	RESSORT À GAZ POUR SELLE		9980210		
MOTORINO D'AVVIAMENTO	STARTER ENGINE	DÉMARREUR ÉLECTRIQUE		MA00010	MA00010	MA00010
PIATTELLO PORTATASSELI	VARIATOR SLIDERS	CURSEURS VARIATEUR			PL04066	PL04066
POMPA BENZINA	FUEL PUMP	POMPE À ESSENCE				
PULEGGIA FISSA	FIXED SHEAVE	POULIE FIXE			PL04075	PL04075
REGOLATORE DI TENSIONE	RECTIFIER	RÉGULATEUR DE TENSION		RE00022		RE00030
RUOTA LIBERA Completa	STARTER CLUTCH SET	ROUE LIBRE Complète				
RUOTA LIBERA RL + flangia	STARTER CLUTCH + FLANGE	ROUE LIBRE RL + flasque		RL00019	RL00010	RL00010
RUOTA LIBERA RL nuda	STARTER CLUTCH	ROUE LIBRE RL nue				
RUOTA LIBERA Ingranaggio	STARTER CLUTCH GEAR	ROUE LIBRE Engrenage		RL00020	RL00011	RL00011
RUOTA LIBERA Flangia	STARTER CLUTCH FLANGE	ROUE LIBRE Flasque				
SERIE DISCHI FRIZIONE	CLUTCH PLATES KIT	JEU DISQUES EMBRAYAGE				
STATORE	STATOR	STATOR		ST00022		ST00002
TASSELLI TRAINO	VARIATOR SLIDERS	CURSEURS VARIATEUR				
VARIATORE VARIOTOP TPR	VARIOTOP TPR	VARIOTOP TPR		9930360	9931790	9931790

YAMAHA	YAMAHA	YAMAHA	YAMAHA	YAMAHA	YAMAHA	YAMAHA	YAMAHA	YAMAHA	YAMAHA	YAMAHA	YAMAHA
MAJESTY E	MAJESTY E	MAJESTY E	MAJESTY E	MAJESTY E	MAXSTER	MAXSTER	NXC CYGNUS X	NXC CYGNUS X	T-MAX 4B5	T-MAX 4B5 ABS	T-MAX 59C
06-06	07-07	08-08	09-09	03-06	01-02	01-02	04-06	07-11	09-11	08-11	12-12
125cc 4T LC	125cc 4T LC	125cc 4T LC	125cc 4T LC	180cc 4T LC	125cc 4T LC	150cc 4T LC	125cc 4T AC	125cc 4T AC	500cc 4T LC	500cc 4T LC	530cc 4T LC
Minarelli YP	Minarelli YP	Minarelli YP	Minarelli YP	Minarelli YP	Minarelli YP	Minarelli YP			4B5	4B5	59C
IM07045	IM07045	IM07045	IM07045		IM07045						
9915380	9915380	9915380	9915380	9915380	9915380	9915380	9931560	9931560	9927550	9927550	
9935700	9935700	9935700	9935700	9935700	9935700	9935700	9935750	9935750			9935960
											9931570
CT00729	CT00729	CT00729	CT00729	CT00729	CT00730	CT00730					
									CT00744	CT00744	
									CT00745	CT00745	
									F007517	F007517	F007517
FZ00371	FZ00371	FZ00371	FZ00371	FZ00401	FZ00371	FZ00401	FZ00371	FZ00371			
9929380	9929380	9929380	9929380		9929380	9929380					
KK01010	KK01010	KK01010	KK01010	KK01010	KK01010	KK01010					
AA00805	AA00805	AA00805	AA00805	AA00805	AA00805	AA00805			AA00820	AA00820	AA00831
									TG00107	TG00107	TG00108
					9915270		9915270	9915270	9922230	9922230	9922210
MC12001	MC12001	MC12001	MC12001	MC12001							
MC12101	MC12101	MC12101	MC12101	MC12101	MC12100	MC12100					
9929170	9929170	9929170	9929170		9929170	9929170			9929880	9929880	9929880
									9980200	9980200	9980200
MA00017	MA00017	MA00017	MA00017	MA00017	MA00017	MA00017	MA00017		MA00033	MA00033	MA00033
RE00030	RE00030	RE00030	RE00030	RE00030					RE00022	RE00022	RE00033
RL00032	RL00032	RL00032	RL00032	RL00032	RL00002	RL00002			RL00015	RL00015	RL00015
									RL00016	RL00016	RL00016
									9928150	9928150	9930880
ST00002	ST00002	ST00002	ST00002	ST00002	ST00002	ST00002			ST00021	ST00021	ST00020
9923550	9923550	9923550	9923550	9923550	9923550	9923550			9927130	9927130	9927130

MAXI SCOOTER

TOP
- performances -



YAMAHA	YAMAHA	YAMAHA	YAMAHA
T-MAX 59C	T-MAX 59C	T-MAX 59C ABS	T-MAX 59C ABS
13-14	15-16	12-12	13-14
530cc 4T LC	530cc 4T LC	530cc 4T LC	530cc 4T LC
59C	59C	59C	59C

IT	EN	FR					
ALBERO A CAMME	CAM SHAFT	ARBRE À CAMES					
ALBERO MOTORE Sel 1/Sel 2	CRANKSHAFT Sel 1/Sel 2	VILEBREQUIN Sél 1/ Sél 2					
CAMPANA FRIZIONE	CLUTCH HOUSING	CLOCHE EMBRAYAGE					
CINGHIA DI TRASMISSIONE Bando	TRANSMISSION BELT Bando	COURROIE DE TRANSMISSION Bando					
CINGHIA DI TRASMISSIONE Mitsuboshi	TRANSMISSION BELT Mitsuboshi	COURROIE DE TRANSMISSION Mitsuboshi		9935960	9935960	9935960	9935960
CINGHIA DI TRASMISSIONE Altro	TRANSMISSION BELT Other	COURROIE DE TRANSMISSION Autres			9931570	9931570	9931570
COLLETTORE ASPIRAZIONE	INLET MANIFOLD	COLLECTEUR ASPIRATION					
COLLETTORE ASPIRAZIONE SX	INLET MANIFOLD LEFT	COLLECTEUR ASPIRATION GAUCHE					
COLLETTORE ASPIRAZIONE DX	INLET MANIFOLD RIGHT	COLLECTEUR ASPIRATION DROITE					
FILTRO OLIO	OIL FILTER	FILTRE À HUILE		F007517	F007517	F007517	
FRIZIONE	CLUTCH	EMBRAYAGE					
GRUPPO TERMICO Standard	CYLINDER KIT Ø standard	CYLINDRE COMPLET Standard					
GRUPPO TERMICO Maggiorato	CYLINDER KIT BIG BORE	CYLINDRE COMPLET Majoré					
KIT CUSCINETTI PARAOLI DI BANCO Serie	BEARINGS AND OIL SEALS KIT	KIT PALIERS JOINTS D'HUILE DE VILEBREQUIN Jeu					
KIT REVISIONE POMPA ACQUA	WATER PUMP REPAIR KIT	KIT RÉVISION POMPE À EAU		AA00831	AA00831	AA00831	
KIT TAGLIANDO	SERVICE KIT	KIT COUPON		TG00108	TG00108	TG00108	
MASSE CENTRIFUGHE PESO ORIGINALE	ROLLER WEIGHTS Standard weight	MASSELOTTE CENTRIFUGES POIDS D'ORIGINE		9922210	9922210	9922210	
MEMBRANA CARBURATORE TIPO ORIGINALE	CARBURETOR DIAPHRAGM OEM	MEMBRANE CARBURATEUR TYPE ORIGINAL					
MEMBRANA CARBURATORE ADATTABILE	CARBURETOR DIAPHRAGM Adaptable	MEMBRANE CARBURATEUR ADAPTABLE					
MOLLE CONTRASTO VARIATORE	REAR VARIATOR SPRING	RESSORTS CONTRASTE VARIATEUR		9929880	9929880	9929880	
MOLLA A GAS PER SELIA	SEAT GAS SPRING	RESSORT À GAZ POUR SELLE		9980200	9980200	9980200	
MOTORINO D'AVVIAMENTO	STARTER ENGINE	DÉMARREUR ÉLECTRIQUE		MA00033	MA00033	MA00033	
PIATTELLO PORTATASSELI	VARIATOR SLIDERS	CURSEURS VARIATEUR					
POMPA BENZINA	FUEL PUMP	POMPE À ESSENCE					
PULEGGIA FISSA	FIXED SHEAVE	POULIE FIXE					
REGOLATORE DI TENSIONE	RECTIFIER	RÉGULATEUR DE TENSION		RE00033	RE00033	RE00033	
RUOTA LIBERA Completa	STARTER CLUTCH SET	ROUE LIBRE Complète				RL00043	
RUOTA LIBERA RL + flangia	STARTER CLUTCH + FLANGE	ROUE LIBRE RL + flasque		RL00015	RL00015	RL00015	RL00015
RUOTA LIBERA RL nuda	STARTER CLUTCH	ROUE LIBRE RL nue					
RUOTA LIBERA Ingranaggio	STARTER CLUTCH GEAR	ROUE LIBRE Engrenage		RL00016	RL00016	RL00016	RL00016
RUOTA LIBERA Flangia	STARTER CLUTCH FLANGE	ROUE LIBRE Flasque					
SERIE DISCHI FRIZIONE	CLUTCH PLATES KIT	JEU DISQUES EMBRAYAGE		9930880	9930880	9930880	
STATORE	STATOR	STATOR		ST00020	ST00020	ST00020	
TASSELLI TRAINO	VARIATOR SLIDERS	CURSEURS VARIATEUR					
VARIATORE VARIOTOP TPR	VARIOTOP TPR	VARIOTOP TPR		9927130	9927130	9927130	

YAMAHA	YAMAHA	YAMAHA	YAMAHA	YAMAHA	YAMAHA	YAMAHA	YAMAHA	YAMAHA	YAMAHA	YAMAHA	YAMAHA
T-MAX 59C ABS	T-MAX 59C SP	T-MAX 59C SP ABS	T-MAX 5GJ	T-MAX 5VU	T-MAX 5VU	T-MAX 5VU	T-MAX 5VU	T-MAX 5VU ABS	T-MAX 5VU ABS	T-MAX 5VU ABS	T-MAX 5VU BLACK MAX
15-16	15-15	15-16	01-03	04-05	06-06	07-07	08-08	05-05	06-06	07-07	06-06
530cc 4T LC	530cc 4T LC	530cc 4T LC	500cc 4T LC	500cc 4T LC	500cc 4T LC	500cc 4T LC	500cc 4T LC	500cc 4T LC	500cc 4T LC	500cc 4T LC	500cc 4T LC
59C	59C	59C	5GJ	5VU	5VU	5VU	5VU	5VU	5VU	5VU	5VU
			9927550	9927550	9927550	9927550	9927550	9927550	9927550	9927550	9927550
9935960	9935960	9935960									
9931570	9931570	9931570									
				CT00744	CT00744	CT00744	CT00744	CT00744	CT00744	CT00744	CT00744
				CT00745	CT00745	CT00745	CT00745	CT00745	CT00745	CT00745	CT00745
F007517	F007517	F007517	F007517	F007517	F007517	F007517	F007517	F007517	F007517	F007517	F007517
AA00831	AA00831	AA00831		AA00820	AA00820	AA00820	AA00820	AA00820	AA00820	AA00820	AA00820
TG00108	TG00108	TG00108	TG00107	TG00107	TG00107	TG00107	TG00107	TG00107	TG00107	TG00107	TG00107
9922210	9922210	9922210	9922250	9922230	9922230	9922230	9922230	9922230	9922230	9922230	9922230
9929880	9929880	9929880	9929880	9929880	9929880	9929880	9929880	9929880	9929880	9929880	9929880
9980200	9980200	9980200					9980200				9980200
MA00033	MA00033	MA00033					MA00033				MA00033
RE00033	RE00033	RE00033		RE00033	RE00033	RE00033	RE00022	RE00033	RE00033	RE00033	RE00033
RL00043	RL00043	RL00043									
RL00015	RL00015	RL00015	RL00015	RL00015	RL00015	RL00015	RL00015	RL00015	RL00015	RL00015	RL00015
RL00016	RL00016	RL00016	RL00016	RL00016	RL00016	RL00016	RL00016	RL00016	RL00016	RL00016	RL00016
9930880	9930880	9930880	9928150	9928150	9928150	9928150	9928150	9928150	9928150	9928150	9928150
ST00020	ST00020	ST00020		ST00019	ST00019	ST00019	ST00021	ST00019	ST00019	ST00019	ST00019
9927130	9927130	9927130	9927130	9927130	9927130	9927130	9927130	9927130	9927130	9927130	9927130

MAXI SCOOTER

MAXI SCOOTER

TOP
- performances -



YAMAHA	YAMAHA	YAMAHA	YAMAHA
T-MAX 5VU BLACK MAX - NIGHT MAX	T-MAX SV	T-MAX SV ABS	T-MAX WHITE MAX
07-07	11-11	10-11	10-10
500cc 4T LC	500cc 4T LC	500cc 4T LC	500cc 4T LC
5VU	4B5	4B5	4B5

IT	EN	FR				
ALBERO A CAMME	CAM SHAFT	ARBRE À CAMES				
ALBERO MOTORE Sel 1/Sel 2	CRANKSHAFT Sel 1/Sel 2	VILEBREQUIN Sel 1/ Sel 2				
CAMPANA FRIZIONE	CLUTCH HOUSING	CLOCHE EMBRAYAGE				
CINGHIA DI TRASMISSIONE Bando	TRANSMISSION BELT Bando	COURROIE DE TRANSMISSION Bando		9927550		
CINGHIA DI TRASMISSIONE Mitsuboshi	TRANSMISSION BELT Mitsuboshi	COURROIE DE TRANSMISSION Mitsuboshi				
CINGHIA DI TRASMISSIONE Altro	TRANSMISSION BELT Other	COURROIE DE TRANSMISSION Autres				
COLLETTORE ASPIRAZIONE	INLET MANIFOLD	COLLECTEUR ASPIRATION				
COLLETTORE ASPIRAZIONE SX	INLET MANIFOLD LEFT	COLLECTEUR ASPIRATION GAUCHE		CT00744		
COLLETTORE ASPIRAZIONE DX	INLET MANIFOLD RIGHT	COLLECTEUR ASPIRATION DROITE		CT00745		
FILTRO OLIO	OIL FILTER	FILTRE À HUILE		F007517		
FRIZIONE	CLUTCH	EMBRAYAGE				
GRUPPO TERMICO Standard	CYLINDER KIT Ø standard	CYLINDRE COMPLET Standard				
GRUPPO TERMICO Maggiorato	CYLINDER KIT BIG BORE	CYLINDRE COMPLET Majoré				
KIT CUSCINETTI PARAOLI DI BANCO Serie	BEARINGS AND OIL SEALS KIT	KIT PALIERS JOINTS D'HUILE DE VILEBREQUIN Jeu				
KIT REVISIONE POMPA ACQUA	WATER PUMP REPAIR KIT	KIT RÉVISION POMPE À EAU		AA00820		
KIT TAGLIANDO	SERVICE KIT	KIT COUPON		TG00107		
MASSE CENTRIFUGHE PESO ORIGINALE	ROLLER WEIGHTS Standard weight	MASSELOTTE CENTRIFUGES POIDS D'ORIGINE		9922230		
MEMBRANA CARBURATORE TIPO ORIGINALE	CARBURETOR DIAPHRAGM OEM	MEMBRANE CARBURATEUR TYPE ORIGINAL				
MEMBRANA CARBURATORE ADATTABILE	CARBURETOR DIAPHRAGM Adaptable	MEMBRANE CARBURATEUR ADAPTABLE				
MOLLE CONTRASTO VARIATORE	REAR VARIATOR SPRING	RESSORTS CONTRASTE VARIATEUR		9929880		
MOLLA A GAS PER SELIA	SEAT GAS SPRING	RESSORT À GAZ POUR SELLE			9980200	9980200
MOTORINO D'AVVIAMENTO	STARTER ENGINE	DÉMARREUR ÉLECTRIQUE			MA00033	MA00033
PIATTELLO PORTATASSELI	VARIATOR SLIDERS	CURSEURS VARIATEUR				
POMPA BENZINA	FUEL PUMP	POMPE À ESSENCE				
PULEGGIA FISSA	FIXED SHEAVE	POULIE FIXE				
REGOLATORE DI TENSIONE	RECTIFIER	RÉGULATEUR DE TENSION		RE00033	RE00022	RE00022
RUOTA LIBERA Completa	STARTER CLUTCH SET	ROUE LIBRE Complète				
RUOTA LIBERA RL + flangia	STARTER CLUTCH + FLANGE	ROUE LIBRE RL + flasque		RL00015		
RUOTA LIBERA RL nuda	STARTER CLUTCH	ROUE LIBRE RL nue				
RUOTA LIBERA Ingranaggio	STARTER CLUTCH GEAR	ROUE LIBRE Engrenage		RL00016		
RUOTA LIBERA Flangia	STARTER CLUTCH FLANGE	ROUE LIBRE Flasque				
SERIE DISCHI FRIZIONE	CLUTCH PLATES KIT	JEU DISQUES EMBRAYAGE		9928150		
STATORE	STATOR	STATOR		ST00019	ST00021	ST00021
TASSELLI TRAINO	VARIATOR SLIDERS	CURSEURS VARIATEUR				
VARIATORE VARIOTOP TPR	VARIOTOP TPR	VARIOTOP TPR		9927130		

YAMAHA	YAMAHA	YAMAHA	YAMAHA	YAMAHA	YAMAHA	YAMAHA	YAMAHA	YAMAHA	YAMAHA	YAMAHA	YAMAHA
TEO'S	TEO'S	VERSITY	VERSITY	VERSITY	X-CITY	X-CITY	X-CITY	X-CITY	X-CITY	X-MAX	X-MAX
00-00	01-02	03-03	04-05	06-06	08-11	07-07	08-08	09-12	13-15	05-06	07-09
125cc 4T LC	150cc 4T LC	300cc 4T LC	300cc 4T LC	300cc 4T LC	125cc 4T-4V LC	250cc 4T LC	250cc 4T LC	250cc 4T LC	250cc 4T LC	250cc 4T LC	250cc 4T LC
Minarelli YP	Minarelli YP	Minarelli YP	Minarelli YP	Minarelli YP	Minarelli						
					9927230						
IM07045					IM07072	IM07054	IM07054	IM07054	IM07054	IM07054	IM07054
		FZ00397	FZ00397	FZ00397	FZ00415	FZ00397	FZ00397	FZ00397	FZ00397	FZ00397	FZ00397
9915380	9915380	9925600	9925600	9925600	9925280	9925600	9925600	9925600	9925600	9925600	9925600
9935700	9935700										
CT00730	CT00730										
					F007523						
FZ00371	FZ00401	FZ00388	FZ00388	FZ00388	FZ00401	FZ00388	FZ00388	FZ00388	FZ00388	FZ00388	FZ00388
					9932700	9926850	9926850	9926850	9926850	9926850	9926850
9929380	9929380				9925180						
KK01010	KK01010	KK01007	KK01007	KK01007		KK01007	KK01007	KK01007	KK01007	KK01007	KK01007
AA00805	AA00805	AA00806	AA00806	AA00806	AA00823	AA00806	AA00806	AA00806	AA00806	AA00806	AA00806
					TG00110	TG00109	TG00109	TG00109	TG00109		TG00109
9915270		9918020	9918020	9918020		9918060	9918060	9918060	9918020	9918020	9918020
		MC12001	MC12001	MC12001							
MC12100	MC12100	MC12101	MC12101	MC12101							
9929170	9929170				9926760	9929870	9929870	9929870	9929870	9929870	9929870
MA00017	MA00017	MA00010	MA00010	MA00010	MA00028	MA00010	MA00010	MA00010	MA00010	MA00010	MA00010
						PL04066	PL04066	PL04066	PL04066	PL04066	PL04066
		PL04075	PL04075	PL04075		PL04075	PL04075	PL04075	PL04075	PL04075	PL04075
	RE00020	RE00022	RE00022	RE00022	RE00023	RE00023	RE00023	RE00023	RE00023	RE00022	RE00023
RL00002	RL00002	RL00010	RL00010	RL00010	RL00034	RL00010	RL00010	RL00010	RL00010	RL00010	RL00010
		RL00011	RL00011	RL00011	RL00035	RL00011	RL00011	RL00011	RL00011	RL00011	RL00011
ST00002	ST00002										
9923550	9923550	9931790	9931790	9931790	9925020	9931790	9931790	9931790	9931790	9931790	9931790

MAXI SCOOTER

TOP
- performances -



YAMAHA	YAMAHA	YAMAHA	YAMAHA
X-MAX	X-MAX	X-MAX	X-MAX
10-12	12-13	14-16	17-17
250cc 4T LC	250cc 4T LC	250cc 4T LC	300cc 4T-4V LC
			Minarelli

IT	EN	FR				
ALBERO A CAMME	CAM SHAFT	ARBRE À CAMES				
ALBERO MOTORE Sel 1/Sel 2	CRANKSHAFT Sel 1/Sel 2	VILEBREQUIN Sél 1/ Sél 2		IM07054	IM07054	IM07054
CAMPANA FRIZIONE	CLUTCH HOUSING	CLOCHE EMBRAYAGE		FZ00397	FZ00397	FZ00397
CINGHIA DI TRASMISSIONE Bando	TRANSMISSION BELT Bando	COURROIE DE TRANSMISSION Bando		9925600	9925600	9925600
CINGHIA DI TRASMISSIONE Mitsuboshi	TRANSMISSION BELT Mitsuboshi	COURROIE DE TRANSMISSION Mitsuboshi				
CINGHIA DI TRASMISSIONE Altro	TRANSMISSION BELT Other	COURROIE DE TRANSMISSION Autres				
COLLETTORE ASPIRAZIONE	INLET MANIFOLD	COLLECTEUR ASPIRATION				
COLLETTORE ASPIRAZIONE SX	INLET MANIFOLD LEFT	COLLECTEUR ASPIRATION GAUCHE				
COLLETTORE ASPIRAZIONE DX	INLET MANIFOLD RIGHT	COLLECTEUR ASPIRATION DROITE				
FILTRO OLIO	OIL FILTER	FILTRE À HUILE				F007523
FRIZIONE	CLUTCH	EMBAYAGE		FZ00388	FZ00388	FZ00388
GRUPPO TERMICO Standard	CYLINDER KIT Ø standard	CYLINDRE COMPLET Standard		9926850	9926850	9926850
GRUPPO TERMICO Maggiorato	CYLINDER KIT BIG BORE	CYLINDRE COMPLET Majoré				
KIT CUSCINETTI PARAOLI DI BANCO Serie	BEARINGS AND OIL SEALS KIT	KIT PALIERS JOINTS D'HUILE DE VILEBREQUIN Jeu		KK01007	KK01007	KK01007
KIT REVISIONE POMPA ACQUA	WATER PUMP REPAIR KIT	KIT RÉVISION POMPE À EAU		AA00806	AA00806	AA00806 AA00844
KIT TAGLIANDO	SERVICE KIT	KIT COUPON		TG00109	TG00109	TG00109
MASSE CENTRIFUGHE PESO ORIGINALE	ROLLER WEIGHTS Standard weight	MASSELOTES CENTRIFUGES POIDS D'ORIGINE		9918060	9918020	9918020 9931890
MEMBRANA CARBURATORE TIPO ORIGINALE	CARBURETOR DIAPHRAGM OEM	MEMBRANE CARBURATEUR TYPE ORIGINAL				
MEMBRANA CARBURATORE ADATTABILE	CARBURETOR DIAPHRAGM Adaptable	MEMBRANE CARBURATEUR ADAPTABLE				
MOLLE CONTRASTO VARIATORE	REAR VARIATOR SPRING	RESSORTS CONTRASTE VARIATEUR		9929870	9929870	9929870
MOLLA A GAS PER SELIA	SEAT GAS SPRING	RESSORT À GAZ POUR SELLE				9980250
MOTORINO D'AVVIAMENTO	STARTER ENGINE	DÉMARREUR ÉLECTRIQUE		MA00010	MA00010	MA00010
PIATTELLO PORTATASSELI	VARIATOR SLIDERS	CURSEURS VARIATEUR		PL04066	PL04066	PL04066 PL04091
POMPA BENZINA	FUEL PUMP	POMPE À ESSENCE				
PULEGGIA FISSA	FIXED SHEAVE	POULIE FIXE		PL04075	PL04075	PL04075 PL04079
REGOLATORE DI TENSIONE	RECTIFIER	RÉGULATEUR DE TENSION		RE00030	RE00030	RE00023
RUOTA LIBERA Completa	STARTER CLUTCH SET	ROUE LIBRE Complète				
RUOTA LIBERA RL + flangia	STARTER CLUTCH + FLANGE	ROUE LIBRE RL + flasque		RL00010	RL00010	RL00010
RUOTA LIBERA RL nuda	STARTER CLUTCH	ROUE LIBRE RL nue				
RUOTA LIBERA Ingranaggio	STARTER CLUTCH GEAR	ROUE LIBRE Engrenage		RL00011	RL00011	RL00011
RUOTA LIBERA Flangia	STARTER CLUTCH FLANGE	ROUE LIBRE Flasque				
SERIE DISCHI FRIZIONE	CLUTCH PLATES KIT	JEU DISQUES EMBRAYAGE				
STATORE	STATOR	STATOR				
TASSELLI TRAINO	VARIATOR SLIDERS	CURSEURS VARIATEUR				AA00853
VARIATORE VARIOTOP TPR	VARIOTOP TPR	VARIOTOP TPR		9931790	9931790	9931790

YAMAHA	YAMAHA	YAMAHA	YAMAHA	YAMAHA	YAMAHA	YAMAHA	YAMAHA	YAMAHA	YAMAHA	YAMAHA	YAMAHA
X-MAX	X-MAX	X-MAX	X-MAX ABS	X-MAX ABS	X-MAX ABS	X-MAX ABS	X-MAX ABS	X-MAX ABS	X-MAX ABS	X-MAX ABS IRON MAX	X-MAX ABS IRON MAX
18-18	13-14	15-16	11-12	14-15	14-15	19-19	20-20	14-14	15-17	19-19	19-19
300cc 4T-4V LC	400cc 4T-4V LC	400cc 4T-4V LC	250cc 4T LC	250cc 4T LC	250cc 4T LC	300cc 4T-4V LC	300cc 4T-4V LC	400cc 4T-4V LC	400cc 4T-4V LC	300cc 4T-4V LC	400cc 4T-4V LC
Minarelli	1SD	1SD				Minarelli	Minarelli	1SD	1SD	Minarelli	1SD
				IM07054	IM07054						
				FZ00397	FZ00397						
			9925600	9925600	9925600						
	9935650	9935650						9935650	9935650		9935650
F007523	F007521	F007521				F007523	F007523	F007521	F007521	F007523	F007521
	FZ00394	FZ00394		FZ00388	FZ00388			FZ00394	FZ00394		FZ00394
				9926850	9926850						
				KK01007	KK01007						
AA00844	AA00818	AA00818		AA00806	AA00806	AA00844	AA00844	AA00818	AA00818	AA00844	AA00818
			TG00109	TG00109	TG00109						
9931890	9922230	9922230		9918020	9918020	9931890	9931890	9922230	9922230	9931890	9922230
				9929870	9929870						
9980250	9980250	9980250			9980250	9980250	9980250	9980250	9980250	9980250	9980250
	MA00010	MA00010		MA00010	MA00010			MA00010	MA00010		MA00010
PL04091			PL04066	PL04066	PL04066	PL04091	PL04091			PL04091	
PL04079			PL04075	PL04075	PL04075	PL04079	PL04079			PL04079	
			RE00030	RE00030	RE00023						
	RL00019	RL00019		RL00010	RL00010			RL00019	RL00019		RL00019
	RL00020	RL00020		RL00011	RL00011			RL00020	RL00020		RL00020
	ST00022							ST00022	ST00022		ST00022
AA00853						AA00853	AA00853			AA00853	
	9930360	9930360	9931790	9931790	9931790			9930360	9930360		9930360

MAXI SCOOTER

TOP
- performances -



YAMAHA	YAMAHA	YAMAHA	YAMAHA
X-MAX ABS TECH MAX	X-MAX BLACK	X-MAX IRON- MAX ABS	X-MAX MO- MODESIGN
20-20	09-09	16-16	14-14
300cc 4T-4V LC	250cc 4T LC	400cc 4T-4V LC	400cc 4T-4V LC
Minarelli		1SD	1SD

IT	EN	FR				
ALBERO A CAMME	CAM SHAFT	ARBRE À CAMES				
ALBERO MOTORE Sel 1/Sel 2	CRANKSHAFT Sel 1/Sel 2	VILEBREQUIN Sél 1/ Sél 2				
CAMPANA FRIZIONE	CLUTCH HOUSING	CLOCHE EMBRAYAGE				
CINGHIA DI TRASMISSIONE Bando	TRANSMISSION BELT Bando	COURROIE DE TRANSMISSION Bando		9925600		
CINGHIA DI TRASMISSIONE Mitsuboshi	TRANSMISSION BELT Mitsuboshi	COURROIE DE TRANSMISSION Mitsuboshi			9935650	9935650
CINGHIA DI TRASMISSIONE Altro	TRANSMISSION BELT Other	COURROIE DE TRANSMISSION Autres				
COLLETTORE ASPIRAZIONE	INLET MANIFOLD	COLLECTEUR ASPIRATION				
COLLETTORE ASPIRAZIONE SX	INLET MANIFOLD LEFT	COLLECTEUR ASPIRATION GAUCHE				
COLLETTORE ASPIRAZIONE DX	INLET MANIFOLD RIGHT	COLLECTEUR ASPIRATION DROITE				
FILTRO OLIO	OIL FILTER	FILTRE À HUILE		F007523	F007521	F007521
FRIZIONE	CLUTCH	EMBRAYAGE			FZ00394	FZ00394
GRUPPO TERMICO Standard	CYLINDER KIT Ø standard	CYLINDRE COMPLET Standard				
GRUPPO TERMICO Maggiorato	CYLINDER KIT BIG BORE	CYLINDRE COMPLET Majoré				
KIT CUSCINETTI PARAOLI DI BANCO Serie	BEARINGS AND OIL SEALS KIT	KIT PALIERS JOINTS D'HUILE DE VILEBREQUIN Jeu				
KIT REVISIONE POMPA ACQUA	WATER PUMP REPAIR KIT	KIT RÉVISION POMPE À EAU		AA00844	AA00818	AA00818
KIT TAGLIANDO	SERVICE KIT	KIT COUPON			TG00109	
MASSE CENTRIFUGHE PESO ORIGINALE	ROLLER WEIGHTS Standard weight	MASSELOTTE CENTRIFUGES POIDS D'ORIGINE		9931890	9922230	9922230
MEMBRANA CARBURATORE TIPO ORIGINALE	CARBURETOR DIAPHRAGM OEM	MEMBRANE CARBURATEUR TYPE ORIGINAL				
MEMBRANA CARBURATORE ADATTABILE	CARBURETOR DIAPHRAGM Adaptable	MEMBRANE CARBURATEUR ADAPTABLE				
MOLLE CONTRASTO VARIATORE	REAR VARIATOR SPRING	RESSORTS CONTRASTE VARIATEUR				
MOLLA A GAS PER SELIA	SEAT GAS SPRING	RESSORT À GAZ POUR SELLE		9980250	9980250	9980250
MOTORINO D'AVVIAMENTO	STARTER ENGINE	DÉMARREUR ÉLECTRIQUE			MA00010	MA00010
PIATTELLO PORTATASSELI	VARIATOR SLIDERS	CURSEURS VARIATEUR		PL04091	PL04066	
POMPA BENZINA	FUEL PUMP	POMPE À ESSENCE				
PULEGGIA FISSA	FIXED SHEAVE	POULIE FIXE		PL04079	PL04075	
REGOLATORE DI TENSIONE	RECTIFIER	RÉGULATEUR DE TENSION			RE00023	
RUOTA LIBERA Completa	STARTER CLUTCH SET	ROUE LIBRE Complète				
RUOTA LIBERA RL + flangia	STARTER CLUTCH + FLANGE	ROUE LIBRE RL + flasque			RL00019	RL00019
RUOTA LIBERA RL nuda	STARTER CLUTCH	ROUE LIBRE RL nue				
RUOTA LIBERA Ingranaggio	STARTER CLUTCH GEAR	ROUE LIBRE Engrenage			RL00020	RL00020
RUOTA LIBERA Flangia	STARTER CLUTCH FLANGE	ROUE LIBRE Flasque				
SERIE DISCHI FRIZIONE	CLUTCH PLATES KIT	JEU DISQUES EMBRAYAGE				
STATORE	STATOR	STATOR			ST00022	ST00022
TASSELLI TRAINO	VARIATOR SLIDERS	CURSEURS VARIATEUR		AA00853		
VARIATORE VARIOTOP TPR	VARIOTOP TPR	VARIOTOP TPR			9931790	9930360

YAMAHA	YAMAHA	YAMAHA	YAMAHA	YAMAHA	YAMAHA	YAMAHA	YAMAHA	YAMAHA	YAMAHA	YAMAHA	YAMAHA
X-MAX MOMODESIGN ABS	X-MAX R	X-MAX R	X-MAX R	X-MAX R	X-MAX R	X-MAX R	X-MAX R	X-MAX R	X-MAX R ABS	X-MAX RA	X-MAX RA ABS
14-14	06-07	08-09	10-12	12-13	14-14	14-14	15-16	11-11	18-18	19-19	13-13
400cc 4T-4V LC	125cc 4T-4V LC	125cc 4T-4V LC	125cc 4T-4V LC	125cc 4T-4V LC	125cc 4T-4V LC	125cc 4T-4V LC	125cc 4T-4V LC	125cc 4T-4V LC	400cc 4T-4V LC	400cc 4T-4V LC	125cc 4T-4V LC
1SD	Minarelli	Minarelli	Minarelli	Minarelli	Minarelli	Minarelli	Minarelli	Minarelli	1SD	1SD	Minarelli
	9927230	9927230	9927230	9927230	9927230	9927230	9927230	9927230			9927230
	IM07072	IM07072	IM07072	IM07072	IM07072		IM07072	IM07072			IM07072
	FZ00415	FZ00415	FZ00415	FZ00415	FZ00415	FZ00415	FZ00415	FZ00415			FZ00415
	9925280	9925280	9925280	9925280	9925280	9925280	9925280	9925280			9925280
9935650									9935650	9935650	
F007521	F007523	F007523	F007523	F007523	F007523	F007523	F007523	F007523	F007521	F007521	F007523
FZ00394	FZ00401	FZ00401	FZ00401	FZ00401	FZ00401	FZ00401	FZ00401	FZ00401	FZ00394	FZ00394	FZ00401
	9932700	9932700	9932700	9932700	9932700	9932700	9932700	9932700			9932700
	9925180	9925180	9925180	9925180	9925180		9925180	9925180			9925180
AA00818	AA00823	AA00823	AA00823	AA00823	AA00823	AA00823	AA00823	AA00823	AA00818	AA00818	AA00823
	TG00110	TG00110	TG00110	TG00110		TG00110	TG00110	TG00110			TG00110
9922230									9922230	9922230	
	9926760	9926760	9926760	9926760	9926760	9926760	9926760	9926760			9926760
9980250					9980250		9980250			9980250	
MA00010	MA00028	MA00028	MA00028	MA00028	MA00028	MA00028	MA00028	MA00028	MA00010	MA00010	MA00028
	RE00023	RE00023	RE00030	RE00030	RE00023	RE00023	RE00023	RE00030			RE00030
RL00019	RL00034	RL00034	RL00034	RL00034	RL00034	RL00034	RL00034	RL00034	RL00019	RL00019	RL00034
RL00020	RL00035	RL00035	RL00035	RL00035	RL00035	RL00035	RL00035	RL00035	RL00020	RL00020	RL00035
ST00022									ST00022	ST00022	
9930360	9925020	9925020	9925020	9925020	9925020	9925020	9925020	9925020	9930360	9930360	9925020

MAXI SCOOTER

MAXI SCOOTER

TOP
- performances -



YAMAHA	YAMAHA	YAMAHA	YAMAHA
X-MAX RA ABS	X-MAX RA ABS	X-MAX RA ABS	X-MAX RA ABS
14-15	16-16	17-17	18-18
125cc 4T-4V LC	125cc 4T-4V LC	125cc 4T-4V LC	125cc 4T-4V LC
Minarelli	Minarelli	Minarelli	Minarelli
9927230	9927230	9927230	9927230
IM07072	IM07072	IM07072	IM07072
FZ00415	FZ00415	FZ00415	FZ00415
9925280	9925280	9925280	9925280
F007523	F007523	F007523	F007523
FZ00401	FZ00401	FZ00401	FZ00401
9932700	9932700	9932700	9932700
9925180	9925180	9925180	9925180
AA00823	AA00823	AA00823	AA00823
TG00110	TG00110	TG00110	TG00110
9926760	9926760	9926760	9926760
9980250	9980250	9980250	9980250
MA00028	MA00028	MA00028	MA00028
RE00023	RE00023	RE00023	RE00023
RL00034	RL00034	RL00034	RL00034
RL00035	RL00035	RL00035	RL00035
9925020	9925020	9925020	9925020

IT	EN	FR
ALBERO A CAMME	CAM SHAFT	ARBRE À CAMES
ALBERO MOTORE Sel 1/Sel 2	CRANKSHAFT Sel 1/Sel 2	VILEBREQUIN Sél 1/ Sél 2
CAMPANA FRIZIONE	CLUTCH HOUSING	CLOCHE EMBRAYAGE
CINGHIA DI TRASMISSIONE Bando	TRANSMISSION BELT Bando	COURROIE DE TRANSMISSION Bando
CINGHIA DI TRASMISSIONE Mitsuboshi	TRANSMISSION BELT Mitsuboshi	COURROIE DE TRANSMISSION Mitsuboshi
CINGHIA DI TRASMISSIONE Altro	TRANSMISSION BELT Other	COURROIE DE TRANSMISSION Autres
COLLETTORE ASPIRAZIONE	INLET MANIFOLD	COLLECTEUR ASPIRATION
COLLETTORE ASPIRAZIONE SX	INLET MANIFOLD LEFT	COLLECTEUR ASPIRATION GAUCHE
COLLETTORE ASPIRAZIONE DX	INLET MANIFOLD RIGHT	COLLECTEUR ASPIRATION DROITE
FILTRO OLIO	OIL FILTER	FILTRE À HUILE
FRIZIONE	CLUTCH	EMBAYAGE
GRUPPO TERMICO Standard	CYLINDER KIT Ø standard	CYLINDRE COMPLET Standard
GRUPPO TERMICO Maggiorato	CYLINDER KIT BIG BORE	CYLINDRE COMPLET Majoré
KIT CUSCINETTI PARAOLI DI BANCO Serie	BEARINGS AND OIL SEALS KIT	KIT PALIERS JOINTS D'HUILE DE VILEBREQUIN Jeu
KIT REVISIONE POMPA ACQUA	WATER PUMP REPAIR KIT	KIT RÉVISION POMPE À EAU
KIT TAGLIANDO	SERVICE KIT	KIT COUPON
MASSE CENTRIFUGHE PESO ORIGINALE	ROLLER WEIGHTS Standard weight	MASSELOTTE CENTRIFUGES POIDS D'ORIGINE
MEMBRANA CARBURATORE TIPO ORIGINALE	CARBURETOR DIAPHRAGM OEM	MEMBRANE CARBURATEUR TYPE ORIGINAL
MEMBRANA CARBURATORE ADATTABILE	CARBURETOR DIAPHRAGM Adaptable	MEMBRANE CARBURATEUR ADAPTABLE
MOLLE CONTRASTO VARIATORE	REAR VARIATOR SPRING	RESSORTS CONTRASTE VARIATEUR
MOLLA A GAS PER SELIA	SEAT GAS SPRING	RESSORT À GAZ POUR SELLE
MOTORINO D'AVVIAMENTO	STARTER ENGINE	DÉMARREUR ÉLECTRIQUE
PIATTELLO PORTATASSELI	VARIATOR SLIDERS	CURSEURS VARIATEUR
POMPA BENZINA	FUEL PUMP	POMPE À ESSENCE
PULEGGIA FISSA	FIXED SHEAVE	POULIE FIXE
REGOLATORE DI TENSIONE	RECTIFIER	RÉGULATEUR DE TENSION
RUOTA LIBERA Completa	STARTER CLUTCH SET	ROUE LIBRE Complète
RUOTA LIBERA RL + flangia	STARTER CLUTCH + FLANGE	ROUE LIBRE RL + flasque
RUOTA LIBERA RL nuda	STARTER CLUTCH	ROUE LIBRE RL nue
RUOTA LIBERA Ingranaggio	STARTER CLUTCH GEAR	ROUE LIBRE Engrenage
RUOTA LIBERA Flangia	STARTER CLUTCH FLANGE	ROUE LIBRE Flasque
SERIE DISCHI FRIZIONE	CLUTCH PLATES KIT	JEU DISQUES EMBRAYAGE
STATORE	STATOR	STATOR
TASSELLI TRAINO	VARIATOR SLIDERS	CURSEURS VARIATEUR
VARIATORE VARIOTOP TPR	VARIOTOP TPR	VARIOTOP TPR

YAMAHA	YAMAHA	YAMAHA	YAMAHA	YAMAHA	YAMAHA	YAMAHA	YAMAHA	YAMAHA	YAMAHA	YAMAHA	YAMAHA
X-MAX RA ABS	X-MAX RA ABS	X-MAX RA ABS	X-MAX RA ABS IRON MAX	X-MAX RA ABS TECH MAX	X-MAX SPORT	XC CYGNUS R	XC CYGNUS R	XC K CYGNUS R	XC T CYGNUS	XC125R MAJESTY S	XENTER
19-19	20-20	20-20	19-19	20-20	11-12	99-99	00-03	97-98	95-98	14-14	12-17
125cc 4T-4V LC	125cc 4T-4V LC	400cc 4T-4V LC	125cc 4T-4V LC	125cc 4T-4V LC	250cc 4T LC	125cc 4T AC	125cc 4T AC	125cc 4T AC	125cc 4T AC	125cc 4T LC	125cc 4T LC
Minarelli	Minarelli	1SD	Minarelli	Minarelli							
9927230	9927230		9927230	9927230							
IM07072	IM07072		IM07072	IM07072							
FZ00415	FZ00415		FZ00415	FZ00415							
9925280	9925280		9925280	9925280	9925600	9931550	9931550	9931550	9931550		
		9935650								9935760	9935760
										9931610	9931610
F007523	F007523	F007521	F007523	F007523							
FZ00401	FZ00401	FZ00394	FZ00401	FZ00401							
9932700	9932700		9932700	9932700							
9925180	9925180		9925180	9925180							
AA00823	AA00823	AA00818	AA00823	AA00823						AA00832	AA00832
TG00110	TG00110		TG00110	TG00110	TG00109						
		9922230				9916220	9916220	9916220	9916220		
9926760	9926760		9926760	9926760							
9980250	9980250	9980250	9980250	9980250							
MA00028	MA00028	MA00010	MA00028	MA00028		MA00017		MA00017	MA00017		
					PL04066						
					PL04075						
RE00023	RE00023		RE00023	RE00023	RE00030						
RL00034	RL00034	RL00019	RL00034	RL00034						RL00038	RL00038
RL00035	RL00035	RL00020	RL00035	RL00035							
		ST00022									
9925020	9925020	9930360	9925020	9925020	9931790						

MAXI SCOOTER

TOP
- performances -



YAMAHA	YAMAHA	YAMAHA	YAMAHA
XENTER	XENTER EU4	XP530-A T-MAX SX	XP530-A T-MAX SX
12-16	20-20	17-17	18-18
150cc 4T LC	125cc 4T LC	530cc 4T LC	530cc 4T LC
		BX3	BX3

IT	EN	FR				
ALBERO A CAMME	CAM SHAFT	ARBRE À CAMES				
ALBERO MOTORE Sel 1/Sel 2	CRANKSHAFT Sel 1/Sel 2	VILEBREQUIN Sél 1/ Sél 2				
CAMPANA FRIZIONE	CLUTCH HOUSING	CLOCHE EMBRAYAGE				
CINGHIA DI TRASMISSIONE Bando	TRANSMISSION BELT Bando	COURROIE DE TRANSMISSION Bando				
CINGHIA DI TRASMISSIONE Mitsuboshi	TRANSMISSION BELT Mitsuboshi	COURROIE DE TRANSMISSION Mitsuboshi		9935760	9935760	9935960
CINGHIA DI TRASMISSIONE Altro	TRANSMISSION BELT Other	COURROIE DE TRANSMISSION Autres		9931610	9931610	
COLLETTORE ASPIRAZIONE	INLET MANIFOLD	COLLECTEUR ASPIRATION				
COLLETTORE ASPIRAZIONE SX	INLET MANIFOLD LEFT	COLLECTEUR ASPIRATION GAUCHE				
COLLETTORE ASPIRAZIONE DX	INLET MANIFOLD RIGHT	COLLECTEUR ASPIRATION DROITE				
FILTRO OLIO	OIL FILTER	FILTRE À HUILE				
FRIZIONE	CLUTCH	EMBAYAGE				
GRUPPO TERMICO Standard	CYLINDER KIT Ø standard	CYLINDRE COMPLET Standard				
GRUPPO TERMICO Maggiorato	CYLINDER KIT BIG BORE	CYLINDRE COMPLET Majoré				
KIT CUSCINETTI PARAOLI DI BANCO Serie	BEARINGS AND OIL SEALS KIT	KIT PALIERS JOINTS D'HUILE DE VILEBREQUIN Jeu				
KIT REVISIONE POMPA ACQUA	WATER PUMP REPAIR KIT	KIT RÉVISION POMPE À EAU		AA00832	AA00832	AA00831
KIT TAGLIANDO	SERVICE KIT	KIT COUPON				
MASSE CENTRIFUGHE PESO ORIGINALE	ROLLER WEIGHTS Standard weight	MASSELOTTE CENTRIFUGES POIDS D'ORIGINE				9922210
MEMBRANA CARBURATORE TIPO ORIGINALE	CARBURETOR DIAPHRAGM OEM	MEMBRANE CARBURATEUR TYPE ORIGINAL				
MEMBRANA CARBURATORE ADATTABILE	CARBURETOR DIAPHRAGM Adaptable	MEMBRANE CARBURATEUR ADAPTABLE				
MOLLE CONTRASTO VARIATORE	REAR VARIATOR SPRING	RESSORTS CONTRASTE VARIATEUR				9929880
MOLLA A GAS PER SELIA	SEAT GAS SPRING	RESSORT À GAZ POUR SELLE				9980200
MOTORINO D'AVVIAMENTO	STARTER ENGINE	DÉMARREUR ÉLECTRIQUE				MA00033
PIATTELLO PORTATASSELI	VARIATOR SLIDERS	CURSEURS VARIATEUR				
POMPA BENZINA	FUEL PUMP	POMPE À ESSENCE				PB00908
PULEGGIA FISSA	FIXED SHEAVE	POULIE FIXE				
REGOLATORE DI TENSIONE	RECTIFIER	RÉGULATEUR DE TENSION				RE00033
RUOTA LIBERA Completa	STARTER CLUTCH SET	ROUE LIBRE Complète				RL00043
RUOTA LIBERA RL + flangia	STARTER CLUTCH + FLANGE	ROUE LIBRE RL + flasque		RL00038	RL00038	
RUOTA LIBERA RL nuda	STARTER CLUTCH	ROUE LIBRE RL nue				
RUOTA LIBERA Ingranaggio	STARTER CLUTCH GEAR	ROUE LIBRE Engrenage				RL00016
RUOTA LIBERA Flangia	STARTER CLUTCH FLANGE	ROUE LIBRE Flasque				
SERIE DISCHI FRIZIONE	CLUTCH PLATES KIT	JEU DISQUES EMBRAYAGE				9930880
STATORE	STATOR	STATOR				ST00020
TASSELLI TRAINO	VARIATOR SLIDERS	CURSEURS VARIATEUR				
VARIATORE VARIOTOP TPR	VARIOTOP TPR	VARIOTOP TPR				9937600

YAMAHA	YAMAHA	YAMAHA	YAMAHA	YAMAHA	YAMAHA	YAMAHA	YAMAHA
XP530-A T-MAX SX	XP530D-A T-MAX DX	XP530D-A T-MAX DX	XP530D-A T-MAX DX	XP530E-A T-MAX	XP530E-A T-MAX	XP560D T-MAX	XP560D T-MAX TECH MAX
19-19	17-17	18-18	19-19	17-17	18-18	20-20	20-20
530cc 4T LC	530cc 4T LC	530cc 4T LC	530cc 4T LC	530cc 4T LC	530cc 4T LC	560cc 4T LC	560cc 4T LC
BX3	BC3	BC3	BC3	BV11	BV11	B7M	B7M
9935960	9935960	9935960	9935960	9935960	9935960	9935960	9935960
AA00831	AA00831	AA00831	AA00831	AA00831	AA00831	AA00831	AA00831
9922210	9922210	9922210	9922210	9922210	9922210		
9929880	9929880	9929880	9929880	9929880	9929880	9929880	9929880
9980200	9980200	9980200	9980200	9980200	9980200	9980200	9980200
MA00033	MA00033	MA00033	MA00033	MA00033	MA00033	MA00033	MA00033
PB00908	PB00908	PB00908	PB00908	PB00908	PB00908		
RE00033	RE00033	RE00033	RE00033	RE00033	RE00033	RE00033	RE00033
RL00043	RL00043	RL00043	RL00043	RL00043	RL00043	RL00043	RL00043
RL00016	RL00016	RL00016	RL00016	RL00016	RL00016		
9930880	9930880	9930880	9930880	9930880	9930880	9930880	9930880
ST00020	ST00020	ST00020	ST00020	ST00020	ST00020	ST00020	ST00020
9937600	9937600	9937600	9937600	9937600	9937600	9937600	9937600



MAXI SCOOTER









MOTO 125cc

TOP
- performances -



BETA	FANTIC	FANTIC	HM
RR	CABALLERO MOTARD	CABALLERO REGOLARITÀ	CITY
10-17	08-18	08-08	11-13
125cc 4T-4V LC	125cc 4T-4V LC	125cc 4T-4V LC	125cc 4T-4V LC
Minarelli - Yamaha MC 125	Minarelli - Yamaha MC 125	Minarelli - Yamaha MC 125	Minarelli - Yamaha MC 125

IT	EN	FR					
ALBERO A CAMME	CAM SHAFT	ARBRE À CAMES		9927230	9927230	9927230	9927230
GRUPPO TERMICO Ø STANDARD	CYLINDER KIT Ø STANDARD	CYLINDRE COMPLET Ø STANDARD		9932700	9932700	9932700	9932700
GRUPPO TERMICO MAGGIORATO	BIG BORE CYLINDER KIT	CYLINDRE COMPLET MAJORÉ		9927120	9927120	9927120	9927120
GRUPPO TERMICO CON CENTRALINA	CYLINDER KIT WITH ECU	CYLINDRE COMPLET DOTÉ DE BOÎTIER ÉLECTRONIQUE					
MOLLE FRIZIONE	CLUTCH SPRINGS	RESSORTS EMBRAYAGE		9927810	9927810	9927810	9927810
SCARICO	EXHAUST	ÉCHAPPEMENT					
FILTRO OLIO	OIL FILTER	FILTRE À HUILE		F007523	F007523	F007523	F007523

HM	HM	HM	HM	HM	HM	HM	HM	HM	HM	HM	HUSQVARNA
CITY	CRE F125X	CRE F125X BAJA	CRE F125X BAJA RR	CRE F125X SIX	CRM F125X	CRM F125X DERAPAGE	CRM F125X DERAPAGE COMPETITION	CRM F125X DERAPAGE RR	LOCUSTA	LOCUSTA	SM
11-13	08-09	10-12	10-12	10-11	08-09	10-12	10-11	10-12	11-13	11-13	10-10
200cc 4T-4V LC	125cc 4T-4V LC	125cc 4T-4V LC	125cc 4T-4V LC	125cc 4T-4V LC	125cc 4T-4V LC	125cc 4T-4V LC	125cc 4T-4V LC	125cc 4T-4V LC	125cc 4T-4V LC	200cc 4T-4V LC	125cc 4T-4V LC
Minarelli - Yamaha MC 200	Minarelli - Yamaha MC 125	Minarelli - Yamaha MC 125	Minarelli - Yamaha MC 125	Minarelli - Yamaha MC 125	Minarelli - Yamaha MC 125	Minarelli - Yamaha MC 125	Minarelli - Yamaha MC 125	Minarelli - Yamaha MC 125	Minarelli - Yamaha MC 125	Minarelli - Yamaha MC 200	Minarelli - Yamaha MC 125
9927230	9927230	9927230	9927230	9927230	9927230	9927230	9927230	9927230	9927230	9927230	9927230
	9932700	9932700	9932700	9932700	9932700	9932700	9932700	9932700	9932700		9932700
9927120	9927120	9927120	9927120	9927120	9927120	9927120	9927120	9927120	9927120	9927120	9927120
9927810	9927810	9927810	9927810	9927810	9927810	9927810	9927810	9927810	9927810	9927810	9927810
F007523	F007523	F007523		F007523	F007523	F007523	F007523	F007523	F007523	F007523	F007523





MOTO 125cc

MOTO 125cc

TOP
- performances -

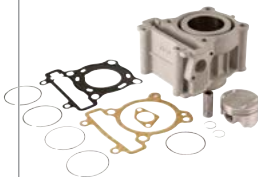
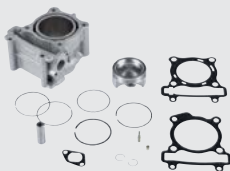





HUSQVARNA	MOTORHISPANIA	MOTORHISPANIA	MOTORHISPANIA
TE	KN1	MH7	RX-R
10-10	08-08	08-08	08-08
125cc 4T-4V LC	125cc 4T-4V LC	125cc 4T-4V LC	125cc 4T-4V LC
Minarelli - Yamaha MC 125	Minarelli - Yamaha MC 125	Minarelli - Yamaha MC 125	Minarelli - Yamaha MC 125

IT	EN	FR				
ALBERO A CAMME	CAM SHAFT	ARBRE À CAMES		9927230	9927230	9927230
GRUPPO TERMICO Ø STANDARD	CYLINDER KIT Ø STANDARD	CYLINDRE COMPLET Ø STANDARD		9932700	9932700	9932700
GRUPPO TERMICO MAGGIORATO	BIG BORE CYLINDER KIT	CYLINDRE COMPLET MAJORÉ		9927120	9927120	9927120
GRUPPO TERMICO CON CENTRALINA	CYLINDER KIT WITH ECU	CYLINDRE COMPLET DOTÉ DE BOÎTIER ÉLECTRONIQUE				
MOLLE FRIZIONE	CLUTCH SPRINGS	RESSORTS EMBRAYAGE		9927810	9927810	9927810
SCARICO	EXHAUST	ÉCHAPPEMENT				
FILTRO OLIO	OIL FILTER	FILTRE À HUILE		F007523	F007523	F007523

RIEJU	RIEJU	RIEJU	RIEJU	VENT	VENT	VENT	VENT	VENT	YAMAHA	YAMAHA	YAMAHA
MARATHON	MARATHON PRO	MARATHON PRO COMPETITION	RS3	BAJA	BAJA RR	DERAPAGE	DERAPAGE RR	TRAIL	MT	MT	MT A
09-09	09-09	11-11	11-11	18-19	18-19	18-19	18-19	18-19	15-15	16-16	15-15
125cc 4T-4V LC	125cc 4T-4V LC	125cc 4T-4V LC	125cc 4T-4V LC	125cc 4T-4V LC	125cc 4T-4V LC	125cc 4T-4V LC	125cc 4T-4V LC	125cc 4T-4V LC	125cc 4T 4V IE LC	125cc 4T 4V IE LC	125cc 4T 4V IE LC
Minarelli - Yamaha MC 125	Minarelli - Yamaha MC 125	Minarelli - Yamaha MC 125	Minarelli - Yamaha MC 125	Minarelli - Yamaha MC 125	Minarelli - Yamaha MC 125	Minarelli - Yamaha MC 125	Minarelli - Yamaha MC 125	Minarelli - Yamaha MC 125	Minarelli - Yamaha MC 125	Minarelli - Yamaha MC 125	Minarelli - Yamaha MC 125
9927230	9927230	9927230	9927230	9927230	9927230	9927230	9927230	9927230	9927230	9927230	9927230
9932700	9932700	9932700	9932700	9932700	9932700	9932700	9932700	9932700	9932700	9932700	9932700
9927120	9927120	9927120	9927120	9927120	9927120	9927120	9927120	9927120	9927120	9927120	9927120
9927810	9927810	9927810	9927810	9927810	9927810	9927810	9927810	9927810	9927810	9927810	9927810
F007523	F007523	F007523	F007523	F007523	F007523	F007523	F007523	F007523	F007523	F007523	F007523

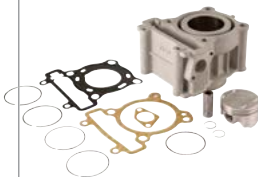
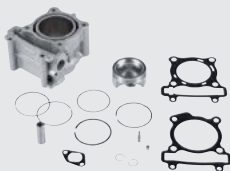
MOTO 125cc





YAMAHA	YAMAHA	YAMAHA	YAMAHA
MT A	MT A	MT A	MT A
16-16	17-17	18-18	19-19
125cc 4T 4V IE LC	125cc 4T 4V IE LC	125cc 4T 4V IE LC	125cc 4T 4V IE LC
Minarelli - Yamaha MC 125	Minarelli - Yamaha MC 125	Minarelli - Yamaha MC 125	Minarelli - Yamaha MC 125 VAR

IT	EN	FR				
ALBERO A CAMME	CAM SHAFT	ARBRE À CAMES		9927230	9927230	9927230
GRUPPO TERMICO Ø STANDARD	CYLINDER KIT Ø STANDARD	CYLINDRE COMPLET Ø STANDARD		9932700	9932700	9932700
GRUPPO TERMICO MAGGIORATO	BIG BORE CYLINDER KIT	CYLINDRE COMPLET MAJORÉ				
GRUPPO TERMICO CON CENTRALINA	CYLINDER KIT WITH ECU	CYLINDRE COMPLET DOTÉ DE BOÎTIER ÉLECTRONIQUE				
MOLLE FRIZIONE	CLUTCH SPRINGS	RESSORTS EMBRAYAGE		9927810	9927810	9927810
SCARICO	EXHAUST	ÉCHAPPEMENT				
FILTRO OLIO	OIL FILTER	FILTRE À HUILE		F007523	F007523	F007523

YAMAHA	YAMAHA	YAMAHA	YAMAHA	YAMAHA	YAMAHA	YAMAHA	YAMAHA	YAMAHA	YAMAHA	YAMAHA	YAMAHA	
MT A	WR-R IE	WR-X IE	WR-X IE	YZF-R A IE	YZF-R A IE	YZF-R A IE	YZF-R A IE	YZF-R A IE	YZF-R A IE	YZF-R A IE	YZF-R A IE MONSTER ENERGY	YZF-R IE
20-20	09-11	09-11	13-14	15-15	16-16	17-17	18-18	19-19	20-20	20-20	20-20	08-11
125cc 4T 4V IE LC	125cc 4T 4V IE LC	125cc 4T 4V IE LC	125cc 4T 4V IE LC	125cc 4T 4V IE LC	125cc 4T 4V IE LC	125cc 4T 4V IE LC	125cc 4T 4V IE LC	125cc 4T 4V IE LC	125cc 4T 4V IE LC	125cc 4T 4V IE LC	125cc 4T 4V IE LC	125cc 4T 4V IE LC
Minarelli - Yamaha MC 125 VAR	Minarelli - Yamaha MC 125	Minarelli - Yamaha MC 125	Minarelli - Yamaha MC 125	Minarelli - Yamaha MC 125	Minarelli - Yamaha MC 125	Minarelli - Yamaha MC 125	Minarelli - Yamaha MC 125	Minarelli - Yamaha MC 125	Minarelli - Yamaha MC 125 VAR	Minarelli - Yamaha MC 125 VAR	Minarelli - Yamaha MC 125 VAR	Minarelli - Yamaha MC 125
	9927230	9927230	9927230	9927230	9927230	9927230	9927230	9927230				9927230
	9932700	9932700	9932700	9932700	9932700	9932700	9932700	9932700				9932700
	9927260	9927260	9927260		9926900	9926900	9926900					9926900
	9927810	9927810	9927810	9927810	9927810	9927810	9927810	9927810				9927810
					9927350	9927350	9927350					9927350
F007523	F007523	F007523	F007523	F007523	F007523	F007523	F007523	F007523	F007523	F007523	F007523	F007523

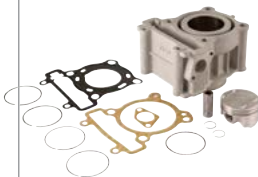
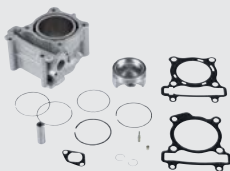
MOTO 125cc

YAMAHA	YAMAHA	YAMAHA	YAMAHA
YZF-R IE	YZF-R IE	YZF-R IE	YZF-R IE
12-12	13-13	14-14	15-15
125cc 4T 4V IE LC	125cc 4T 4V IE LC	125cc 4T 4V IE LC	125cc 4T 4V IE LC
Minarelli - Yamaha MC 125	Minarelli - Yamaha MC 125	Minarelli - Yamaha MC 125	Minarelli - Yamaha MC 125

IT	EN	FR				
ALBERO A CAMME	CAM SHAFT	ARBRE À CAMES		9927230	9927230	9927230
GRUPPO TERMICO Ø STANDARD	CYLINDER KIT Ø STANDARD	CYLINDRE COMPLET Ø STANDARD		9932700	9932700	9932700
GRUPPO TERMICO MAGGIORATO	BIG BORE CYLINDER KIT	CYLINDRE COMPLET MAJORÉ				
GRUPPO TERMICO CON CENTRALINA	CYLINDER KIT WITH ECU	CYLINDRE COMPLET DOTÉ DE BOÎTIER ÉLECTRONIQUE		9926900	9926900	
MOLLE FRIZIONE	CLUTCH SPRINGS	RESSORTS EMBRAYAGE		9927810	9927810	9927810
SCARICO	EXHAUST	ÉCHAPPEMENT		9927350	9927350	
FILTRO OLIO	OIL FILTER	FILTRE À HUILE		F007523	F007523	F007523

YAMAHA

YZF-R1E

16-16

125cc 4T 4V
IE LC

Minarelli -
Yamaha MC 125

9927230

9932700

9926900

9927810













9927350

F007523



MOTO 125cc

DINLI	DINLI	DINLI	E-TON
HELIX DL603	HELIX DL603 90	T-REX	VIPER RXL
07-13	07-13	07-13	06-06
50cc 2T AC	50cc 2T AC	50cc 2T AC	50cc 2T AC

IT	EN	FR				
ALBERO MOTORE	Crankshaft	VILEBREQUIN				
CAMPANA + FRIZIONE	CLUTCH + CLUTCH HOUSING	CLOCHE + EMBRAYAGE		9925130	9925130	9925130
CINGHIA DI TRASMISSIONE TOP	TRANSMISSION BELT TOP	COURROIE DE TRANSMISSION TOP		9907900	9907900	9907900
CONVERTITORE DI COPPIA	TORQUE CONVERTER	CONVERTISSEUR DE COUPLE				
GRUPPO TERMICO Ø 40 standard	CYLINDER KIT Ø 40 standard	CYLINDRE COMPLET Ø 40 Standard		9931140		9931140
GRUPPO TERMICO Ø maggiorato	CYLINDER KIT BIG BORE	CYLINDRE COMPLET Ø majoré		9931340		9931340
RUOTA LIBERA ingranaggio	STARTER CLUTCH GEAR	ROUE LIBRE engrenage				
RUOTA LIBERA con flangia	STARTER CLUTCH + FLANGE	ROUE LIBRE avec flasque				
KIT CUSCINETTI E PARAOLI	BEARINGS AND OIL SEALS KIT	KIT PALIERS ET JOINTS D'HUILE				
KIT REVISIONE POMPA ACQUA	WATER PUMP REPAIR KIT	KIT RÉVISION POMPE À EAU				
MOTORINO AVVIAMENTO	STARTER ENGINE	DÉMARREUR ÉLECTRIQUE				
VALVOLA LAMELLARE	REED VALVE	CLAPET À LAMELLES		9908370	9908370	9908370
VARIOTOP TPR	VARIOTOP TPR	VARIOTOP TPR				

GILERA	KEEWAY	KEEWAY	KYMCO	KYMCO	KYMCO	KYMCO	KYMCO	KYMCO	KYMCO	KYMCO	KYMCO
OREGON	ATV EC2	ATV OFF ROAD	KXR	KXR	MAXXER	MAXXER	MXER	MXER EU2	MXU	MXU	MXU
06-10	06-06	07-07	04-04	03-04	05-05	05-06	02-03	04-04	06-07	05-05	05-06
250cc 4T LC	50cc 2T AC	50cc 2T AC	50cc 2T AC	250cc 4T LC	50cc 2T AC	300cc 4T LC	50cc 2T AC	50cc 2T AC	50cc 2T AC	250cc 4T LC	300cc 4T LC
	Motore Keeway	Motore Keeway									
	9925130	9925130									
	9913280	9913280									
	9923030	9923030									
	9925650	9925650									
	9924890	9924890									
				RL00009		RL00009				RL00009	RL00009
				RL00008		RL00008				RL00008	RL00008 RL00028
			KK01013		KK01013		KK01013	KK01013	KK01013	KK01013	
AA00828											
MA00016			MA00014		MA00014		MA00014	MA00014	MA00014	MA00014	
	9908370	9908370									
	9924900	9924900									

ATV QUAD



ATV QUAD

TOP
- performances -



KYMCO **KYMCO** **LAVERDA**

MXU R MXU SR QUASAR

10-10 06-06 02-04

300cc 4T LC 50cc 2T AC 50cc 2T AC

IT	EN	FR			
ALBERO MOTORE	Crankshaft	VILEBREQUIN			
CAMPANA + FRIZIONE	CLUTCH + CLUTCH HOUSING	CLOCHE + EMBRAYAGE			9925130
CINGHIA DI TRASMISSIONE TOP	TRANSMISSION BELT TOP	COURROIE DE TRANSMISSION TOP			9907900
CONVERTITORE DI COPPIA	TORQUE CONVERTER	CONVERTISSEUR DE COUPLE			
GRUPPO TERMICO Ø 40 standard	CYLINDER KIT Ø 40 standard	CYLINDRE COMPLET Ø 40 Standard			9931140
GRUPPO TERMICO Ø maggiorato	CYLINDER KIT BIG BORE	CYLINDRE COMPLET Ø majoré			9931340
RUOTA LIBERA ingranaggio	STARTER CLUTCH GEAR	ROUE LIBRE engrenage		RL00031	
RUOTA LIBERA con flangia	STARTER CLUTCH + FLANGE	ROUE LIBRE avec flasque		RL00028	
KIT CUSCINETTI E PARAOLI	BEARINGS AND OIL SEALS KIT	KIT PALIERS ET JOINTS D'HUILE			KK01013
KIT REVISIONE POMPA ACQUA	WATER PUMP REPAIR KIT	KIT RÉVISION POMPE À EAU			
MOTORINO AVVIAMENTO	STARTER ENGINE	DÉMARREUR ÉLECTRIQUE			MA00014
VALVOLA LAMELLARE	REED VALVE	CLAPET À LAMELLES			9908370
VARIOTOP TPR	VARIOTOP TPR	VARIOTOP TPR			



ATV QUAD



LML	LML	LML	LML
STAR DELUXE EU1	STAR DELUXE EU1	STAR DELUXE EU3	STAR DELUXE EU3
01-03	01-03	08-09	08-09
125cc 2T AC	150cc 2T AC	125cc 2T AC	150cc 2T AC

IT	EN	FR				
ALBERI MESSA IN MOTO	KICK SHAFT	ARBRE DE DEMARREUR				
ALBERO MOTORE	CRANKSHAFT	VILEBREQUIN				
BIELLA	CONROD	BIELLE				
CARBURATORE	CARBURETOR	CARBURATEUR				
CENTRALINA ACCENSIONE	CDI	Unité de contrôle				
CILINDRETTI FRENO	BRAKE CALLIPERS	CYLINDRES FREIN				
FRIZIONI	CLUTCH	EMBRAYAGE		FZ00307	FZ00307	FZ00307
GANASCE FRENO	BRAKE SHOE	MÂCHOIRES FREIN				
GRUPPO TERMICO Ø Standard Spinotto 10	GRUPPO TERMICO Ø Standard pin 10	CYLINDRE COMPLET Ø Standard Axe de Piston Ø 10				
GRUPPO TERMICO Ø Standard Spinotto 12	CYLINDER KIT Ø Standard Pin 12	CYLINDRE COMPLET Ø Standard Axe de Piston Ø 12				
GRUPPO TERMICO Ø Maggiorato Spinotto 10	CYLINDER KIT BIG BORE pin 10	CYLINDRE COMPLET Ø majoré Axe de Piston Ø 10				
GRUPPO TERMICO Ø Maggiorato Spinotto 12	CYLINDER KIT BIG BORE pin 12	CYLINDRE COMPLET Ø majoré Axe de Piston Ø 12				
GRUPPO TERMICO Ø 47 3 Travasi	CYLINDER KIT Ø 47 3 Ports	CYLINDRE COMPLET Ø 47 3 Transvasements				
GRUPPO TERMICO Ø 47 6 Travasi	CYLINDER KIT Ø 47 6 Ports	CYLINDRE COMPLET Ø 47 6 Transvasements				
GRUPPO TERMICO Ø 47 10 Luci	CYLINDER KIT Ø 47 10 Ports	CYLINDRE COMPLET Ø 47 10 Ouvertures				
GRUPPO TERMICO Ø 50 3 Travasi	CYLINDER KIT Ø 50 3 Ports	CYLINDRE COMPLET Ø 50 3 Transvasements				
GRUPPO TERMICO Ø 55 6 Travasi	CYLINDER KIT Ø 55 6 Ports	CYLINDRE COMPLET Ø 55 6 Transvasements				
GRUPPO TERMICO Ø 57 c/testa	CYLINDER KIT Ø 57 with cylinder head	CYLINDRE COMPLET Ø 57 avec culasse				
GRUPPO TERMICO Ø 60 c/testa	CYLINDER KIT Ø 60 with cylinder head	CYLINDRE COMPLET Ø 60 avec culasse				
GRUPPO TERMICO Ø 63 con testa	CYLINDER KIT Ø 63	CYLINDRE COMPLET Ø 63		KT00017	KT00017	KT00017
GRUPPO TERMICO Ø 69 Spinotto 18	CYLINDER KIT Ø 69 Pin 18	CYLINDRE COMPLET Ø 69 Axe de Piston Ø 18				
GRUPPO TERMICO Ø 69 Spinotto 16	CYLINDER KIT Ø 69 Pin 16	CYLINDRE COMPLET Ø 69 Axe de Piston Ø 16				
GRUPPO TERMICO Ø Maggiorato Alluminio	CYLINDER KIT BIG BORE Aluminium	CYLINDRE COMPLET Ø majoré aluminium		KT00136	KT00136	KT00136
INTERMITTENZA FRECCIE	FLASHER RELAY	RELAIS CLIGNOTANTS				
KIT ASPIRAZIONE	INLET KIT	KIT ASPIRATION				
KIT CUSCINETTI BANCO	BEARINGS KIT	KIT PALIERS DE VILEBREQUIN				
MOLLE FRIZIONE	CLUTCH SPRINGS	RESSORTS EMBRAYAGE		ML00821	ML00821	ML00821
MOTORINO AVVIAMENTO	STARTER ENGINE	DÉMARREUR ÉLECTRIQUE				
REGOLATORE DI TENSIONE	RECTIFIER	RÉGULATEUR DE TENSION				
SCARICHI	EXHAUST	ÉCHAPPEMENT				
SERIE GUARNIZIONI MOTORE	ENGINE GASKET SET	JEU DE JOINTS MOTEUR				
SERIE PARAOLI BANCO	CRANKSHAFT OIL SEAL KIT	SÉRIE DE JOINTS DE BANC				
SERIE PARAOLI MOTORE	ENGINE OIL SEAL KIT	SÉRIE DE JOINTS MOTEUR				
STATORE	STATOR	STATOR				

PIAGGIO	PIAGGIO	PIAGGIO	PIAGGIO	PIAGGIO	PIAGGIO	PIAGGIO	PIAGGIO	PIAGGIO	PIAGGIO	PIAGGIO	PIAGGIO
APE	APE	APE CAR P2 (1° SERIE)	APE EU4	APE FL - FL2	APE FL3 EUROPA	APE MIX 2T	APE MP	APE MPM 600	APE MPR 500	APE MPV 600	APE P
09-11	12-17	78-82	18-18	89-95	96-99	98-08	78-96	78-83	78-83	78-83	80-85
50cc 2T AC	50cc 2T AC	220cc 2T AC	50cc 2T LC	50cc 2T AC	50cc 2T AC	50cc 2T AC	220cc 2T AC	220cc 2T AC	220cc 2T AC	220cc 2T AC	50cc 2T AC
IM07007 IM07008	IM07007 IM07008		IM07007 IM07008	IM07007 IM07008	IM07007 IM07008	IM07007 IM07008					
IM07024	IM07024		IM07024	IM07024	IM07024	IM07024					IM07024
CA00002				CA00002	CA00002	CA00002					
CF12757	CF12757	CF12750		CF12757	CF12757	CF12757					
FZ00329	FZ00329		FZ00329	FZ00329	FZ00329	FZ00329					FZ00301 FZ00302 FZ00306
KT00010	KT00010			KT00010	KT00010	KT00010					KT00010
KT00011	KT00011			KT00011	KT00011	KT00011					KT00011
KT00013	KT00013			KT00013	KT00013	KT00013					KT00013
KT00049	KT00049			KT00049	KT00049	KT00049					KT00049
KT00012	KT00012			KT00012	KT00012	KT00012					KT00012
KT00014	KT00014			KT00014	KT00014	KT00014					KT00014
		KT00019									
							KT00020	KT00020	KT00020	KT00020	
											ME00001
KK01012	KK01012		KK01012	KK01012	KK01012	KK01012					KK01011
											ML00820
MA00023	MA00023		MA00023	MA00023	MA00023	MA00023					
				RE00009	RE00009						
K060100	K060100		K060100	K060100	K060100	K060100					K060040
											K06004A

DR Classic



PIAGGIO	PIAGGIO	PIAGGIO	PIAGGIO
APE P 501	APE P 601	APE P 601V	APE RST MIX
78-85	78-83	78-83	99-03
220cc 2T AC	220cc 2T AC	220cc 2T AC	50cc 2T AC

IT	EN	FR	Image			
ALBERI MESSA IN MOTO	KICK SHAFT	ARBRE DE DEMARREUR				
ALBERO MOTORE	CRANKSHAFT	VILEBREQUIN				
BIELLA	CONROD	BIELLE				
CARBURATORE	CARBURETOR	CARBURATEUR				
CENTRALINA ACCENSIONE	CDI	Unité de contrôle				
CILINDRETTI FRENO	BRAKE CALLIPERS	CYLINDRES FREIN		CF12750	CF12750	CF12757
FRIZIONI	CLUTCH	EMBAYAGE				
GANASCE FRENO	BRAKE SHOE	MÂCHOIRES FREIN				
GRUPPO TERMICO Ø Standard Spinotto 10	GRUPPO TERMICO Ø Standard pin 10	CYLINDRE COMPLET Ø Standard Axe de Piston Ø 10				
GRUPPO TERMICO Ø Standard Spinotto 12	CYLINDER KIT Ø Standard Pin 12	CYLINDRE COMPLET Ø Standard Axe de Piston Ø 12				
GRUPPO TERMICO Ø Maggiorato Spinotto 10	CYLINDER KIT BIG BORE pin 10	CYLINDRE COMPLET Ø majoré Axe de Piston Ø 10				
GRUPPO TERMICO Ø Maggiorato Spinotto 12	CYLINDER KIT BIG BORE pin 12	CYLINDRE COMPLET Ø majoré Axe de Piston Ø 12				
GRUPPO TERMICO Ø 47 3 Travasi	CYLINDER KIT Ø 47 3 Ports	CYLINDRE COMPLET Ø 47 3 Transvasements				
GRUPPO TERMICO Ø 47 6 Travasi	CYLINDER KIT Ø 47 6 Ports	CYLINDRE COMPLET Ø 47 6 Transvasements				
GRUPPO TERMICO Ø 47 10 Luci	CYLINDER KIT Ø 47 10 Ports	CYLINDRE COMPLET Ø 47 10 Ouvertures				
GRUPPO TERMICO Ø 50 3 Travasi	CYLINDER KIT Ø 50 3 Ports	CYLINDRE COMPLET Ø 50 3 Transvasements				
GRUPPO TERMICO Ø 55 6 Travasi	CYLINDER KIT Ø 55 6 Ports	CYLINDRE COMPLET Ø 55 6 Transvasements				
GRUPPO TERMICO Ø 57 c/testa	CYLINDER KIT Ø 57 with cylinder head	CYLINDRE COMPLET Ø 57 avec culasse				
GRUPPO TERMICO Ø 60 c/testa	CYLINDER KIT Ø 60 with cylinder head	CYLINDRE COMPLET Ø 60 avec culasse				
GRUPPO TERMICO Ø 63 con testa	CYLINDER KIT Ø 63	CYLINDRE COMPLET Ø 63				
GRUPPO TERMICO Ø 69 Spinotto 18	CYLINDER KIT Ø 69 Pin 18	CYLINDRE COMPLET Ø 69 Axe de Piston Ø 18		KT00019	KT00019	KT00019
GRUPPO TERMICO Ø 69 Spinotto 16	CYLINDER KIT Ø 69 Pin 16	CYLINDRE COMPLET Ø 69 Axe de Piston Ø 16				
GRUPPO TERMICO Ø Maggiorato Alluminio	CYLINDER KIT BIG BORE Aluminium	CYLINDRE COMPLET Ø majoré aluminium				
INTERMITTENZA FRECCE	FLASHER RELAY	RELAIS CLIGNOTANTS				
KIT ASPIRAZIONE	INLET KIT	KIT ASPIRATION				
KIT CUSCINETTI BANCO	BEARINGS KIT	KIT PALIERS DE VILEBREQUIN				
MOLLE FRIZIONE	CLUTCH SPRINGS	RESSORTS EMBRAYAGE				
MOTORINO AVVIAMENTO	STARTER ENGINE	DÉMARREUR ÉLECTRIQUE				
REGOLATORE DI TENSIONE	RECTIFIER	RÉGULATEUR DE TENSION				
SCARICHI	EXHAUST	ÉCHAPPEMENT				
SERIE GUARNIZIONI MOTORE	ENGINE GASKET SET	JEU DE JOINTS MOTEUR				
SERIE PARAOLI BANCO	CRANKSHAFT OIL SEAL KIT	SÉRIE DE JOINTS DE BANC				
SERIE PARAOLI MOTORE	ENGINE OIL SEAL KIT	SÉRIE DE JOINTS MOTEUR				
STATORE	STATOR	STATOR				

PIAGGIO	PIAGGIO	PIAGGIO	PIAGGIO	PIAGGIO	PIAGGIO	PIAGGIO	PIAGGIO	PIAGGIO	PIAGGIO	PIAGGIO	PIAGGIO
APE TM	APE TM P	APE TM P 602	APE TM P 703 - P 703 V, FL2	BOSS	BOXER	BRAVO 3	BRAVO ERRE 2	CIAO	CIAO EU1	CIAO EU2	CIAO MIX TEEN
09-16	85-89	82-83	84-05	88-89	70-83	87-90	75-81	80-88	99-01	02-04	96-01
220cc 2T AC	50cc 2T AC	220cc 2T AC	220cc 2T AC	50cc 2T AC	50cc 2T AC	50cc 2T AC	50cc 2T AC	50cc 2T AC	50cc 2T AC	50cc 2T AC	50cc 2T AC
	IM07007 IM07008										
	IM07024										
								CB03003	CB03003	CB03003	CB03003
	CA00002										
CF12754 CF12755		CF12754 CF12755	CF12754 CF12755								
	FZ00301 FZ00302 FZ00306						FZ00320	FZ00320	FZ00320	FZ00320	FZ00320
				KT00005	KT00005	KT00005	KT00005	KT00005	KT00005	KT00005	KT00005
KT00010				KT00004	KT00004	KT00004	KT00004	KT00004	KT00004	KT00004	KT00004
				KT00067	KT00067	KT00067	KT00067	KT00067	KT00067	KT00067	KT00067
				KT00066	KT00066	KT00066	KT00066	KT00066	KT00066	KT00066	KT00066
	KT00011										
	KT00013										
	KT00049										
	KT00012										
	KT00014										
	ME00001			ME00001							
	KK01012										
	ML00820										
	MA00023										
	RE00008										
						MT00025 MT00026	MT00025 MT00026	MT00025 MT00026	MT00025 MT00026	MT00025 MT00026	MT00025 MT00026
	K060100										



PIAGGIO	PIAGGIO	PIAGGIO	PIAGGIO
CIAO TRE	COSA 2	COSA 2	COSA 2
71-99	91-97	91-97	91-97
50cc 2T AC	125cc 2T AC	150cc 2T AC	200cc 2T AC

IT	EN	FR				
ALBERI MESSA IN MOTO	KICK SHAFT	ARBRE DE DEMARREUR				CI07497
ALBERO MOTORE	CRANKSHAFT	VILEBREQUIN				
BIELLA	CONROD	BIELLE				
CARBURATORE	CARBURETOR	CARBURATEUR		CB03003		
CENTRALINA ACCENSIONE	CDI	Unité de contrôle			CA00002	CA00002
CILINDRETTI FRENO	BRAKE CALLIPERS	CYLINDRES FREIN				
FRIZIONI	CLUTCH	EMBAYAGE			FZ00313	
GANASCE FRENO	BRAKE SHOE	MÂCHOIRES FREIN				
GRUPPO TERMICO Ø Standard Spinotto 10	GRUPPO TERMICO Ø Standard pin 10	CYLINDRE COMPLET Ø Standard Axe de Piston Ø 10		KT00005		
GRUPPO TERMICO Ø Standard Spinotto 12	CYLINDER KIT Ø Standard Pin 12	CYLINDRE COMPLET Ø Standard Axe de Piston Ø 12		KT00004		
GRUPPO TERMICO Ø Maggiorato Spinotto 10	CYLINDER KIT BIG BORE pin 10	CYLINDRE COMPLET Ø majoré Axe de Piston Ø 10		KT00067		
GRUPPO TERMICO Ø Maggiorato Spinotto 12	CYLINDER KIT BIG BORE pin 12	CYLINDRE COMPLET Ø majoré Axe de Piston Ø 12		KT00066		
GRUPPO TERMICO Ø 47 3 Travasi	CYLINDER KIT Ø 47 3 Ports	CYLINDRE COMPLET Ø 47 3 Transvasements				
GRUPPO TERMICO Ø 47 6 Travasi	CYLINDER KIT Ø 47 6 Ports	CYLINDRE COMPLET Ø 47 6 Transvasements				
GRUPPO TERMICO Ø 47 10 Luci	CYLINDER KIT Ø 47 10 Ports	CYLINDRE COMPLET Ø 47 10 Ouvertures				
GRUPPO TERMICO Ø 50 3 Travasi	CYLINDER KIT Ø 50 3 Ports	CYLINDRE COMPLET Ø 50 3 Transvasements				
GRUPPO TERMICO Ø 55 6 Travasi	CYLINDER KIT Ø 55 6 Ports	CYLINDRE COMPLET Ø 55 6 Transvasements				
GRUPPO TERMICO Ø 57 c/testa	CYLINDER KIT Ø 57 with cylinder head	CYLINDRE COMPLET Ø 57 avec culasse				
GRUPPO TERMICO Ø 60 c/testa	CYLINDER KIT Ø 60 with cylinder head	CYLINDRE COMPLET Ø 60 avec culasse				
GRUPPO TERMICO Ø 63 con testa	CYLINDER KIT Ø 63	CYLINDRE COMPLET Ø 63				
GRUPPO TERMICO Ø 69 Spinotto 18	CYLINDER KIT Ø 69 Pin 18	CYLINDRE COMPLET Ø 69 Axe de Piston Ø 18				
GRUPPO TERMICO Ø 69 Spinotto 16	CYLINDER KIT Ø 69 Pin 16	CYLINDRE COMPLET Ø 69 Axe de Piston Ø 16				
GRUPPO TERMICO Ø Maggiorato Alluminio	CYLINDER KIT BIG BORE Aluminium	CYLINDRE COMPLET Ø majoré aluminium				
INTERMITTENZA FRECCHE	FLASHER RELAY	RELAIS CLIGNOTANTS			ME00001	ME00001
KIT ASPIRAZIONE	INLET KIT	KIT ASPIRATION				
KIT CUSCINETTI BANCO	BEARINGS KIT	KIT PALIERS DE VILEBREQUIN				
MOLLE FRIZIONE	CLUTCH SPRINGS	RESSORTS EMBRAYAGE			ML06181	
MOTORINO AVVIAMENTO	STARTER ENGINE	DÉMARREUR ÉLECTRIQUE				
REGOLATORE DI TENSIONE	RECTIFIER	RÉGULATEUR DE TENSION			RE00008	RE00008
SCARICHI	EXHAUST	ÉCHAPPEMENT		MT00025 MT00026		
SERIE GUARNIZIONI MOTORE	ENGINE GASKET SET	JEU DE JOINTS MOTEUR			GR00744	GR00744
SERIE PARAOLI BANCO	CRANKSHAFT OIL SEAL KIT	SÉRIE DE JOINTS DE BANC				
SERIE PARAOLI MOTORE	ENGINE OIL SEAL KIT	SÉRIE DE JOINTS MOTEUR			K060050	K060050
STATORE	STATOR	STATOR				

PIAGGIO	PIAGGIO	PIAGGIO	PIAGGIO	PIAGGIO	PIAGGIO	PIAGGIO	PIAGGIO	PIAGGIO	PIAGGIO	PIAGGIO	PIAGGIO
COSA CL, CLX	COSA CL, CLX	COSA CL, CLX	ECO	GRILLO	SI	SI FL2	SI MIX	VESPA ET2	VESPA ET2	VESPA ET3	VESPA FL
88-91	88-91	88-91	79-89	89-93	79-88	91-97	96-99	97-98	98-05	76-83	89-90
125cc 2T AC	150cc 2T AC	200cc 2T AC	50cc 2T AC	50cc 2T AC	50cc 2T AC	50cc 2T AC	50cc 2T AC	50cc 2T AC	50cc 2T AC	125cc 2T AC	125cc 2T AC
								Motore Piaggio	Motore Piaggio		
CI07497	CI07497	CI07497									
										IM07067 IM07077	
					CB03002	CB03002	CB03002				
CA00002	CA00002									CA00002	CA00002
FZ00303 FZ00307	FZ00303	FZ00305 FZ00318		FZ00320	FZ00320	FZ00320	FZ00320			FZ00301 FZ00302 FZ00306	FZ00329
											CP00212
				KT00005	KT00005	KT00005	KT00005				
				KT00004	KT00004	KT00004	KT00004				
			KT00067	KT00067	KT00067	KT00067	KT00067				
			KT00066	KT00066	KT00066	KT00066	KT00066				
										KT00015	
ME00001	ME00001	ME00001		ME00001		ME00001	ME00001			KT00135	ME00001
MA00029											MA00023
RE00008	RE00008	RE00008						RE00009	RE00009		RE00008
										MT00002	
GR00744	GR00744	GR00745								GR00742	GR00743
										K060040	
K060050	K060050	K060050								K06004A	



PIAGGIO	PIAGGIO	PIAGGIO	PIAGGIO
VESPA FL	VESPA FL2 AUTOMATICA	VESPA FL2 HP	VESPA N
90-90	90-91	91-97	89-90
50cc 2T AC	50cc 2T AC	50cc 2T AC	50cc 2T AC

IT	EN	FR					
ALBERI MESSA IN MOTO	KICK SHAFT	ARBRE DE DEMARREUR				CI07498	CI07498
ALBERO MOTORE	CRANKSHAFT	VILEBREQUIN		IM07007 IM07008			IM07007 IM07008
BIELLA	CONROD	BIELLE		IM07024	IM07024	IM07024	IM07024
CARBURATORE	CARBURETOR	CARBURATEUR					
CENTRALINA ACCENSIONE	CDI	Unité de contrôle		CA00002	CA00002	CA00002	CA00002
CILINDRETTI FRENO	BRAKE CALLIPERS	CYLINDRES FREIN					
FRIZIONI	CLUTCH	EMBRAYAGE		FZ00329		FZ00329	FZ00301 FZ00302 FZ00306
GANASCE FRENO	BRAKE SHOE	MÂCHOIRES FREIN		CP00212	CP00212	CP00212	CP00212
GRUPPO TERMICO Ø Standard Spinotto 10	GRUPPO TERMICO Ø Standard pin 10	CYLINDRE COMPLET Ø Standard Axe de Piston Ø 10					
GRUPPO TERMICO Ø Standard Spinotto 12	CYLINDER KIT Ø Standard Pin 12	CYLINDRE COMPLET Ø Standard Axe de Piston Ø 12		KT00010		KT00010	KT00010
GRUPPO TERMICO Ø Maggiorato Spinotto 10	CYLINDER KIT BIG BORE pin 10	CYLINDRE COMPLET Ø majoré Axe de Piston Ø 10					
GRUPPO TERMICO Ø Maggiorato Spinotto 12	CYLINDER KIT BIG BORE pin 12	CYLINDRE COMPLET Ø majoré Axe de Piston Ø 12					
GRUPPO TERMICO Ø 47 3 Travasi	CYLINDER KIT Ø 47 3 Ports	CYLINDRE COMPLET Ø 47 3 Transvasements		KT00011		KT00011	KT00011
GRUPPO TERMICO Ø 47 6 Travasi	CYLINDER KIT Ø 47 6 Ports	CYLINDRE COMPLET Ø 47 6 Transvasements		KT00013		KT00013	KT00013
GRUPPO TERMICO Ø 47 10 Luci	CYLINDER KIT Ø 47 10 Ports	CYLINDRE COMPLET Ø 47 10 Ouvertures		KT00049		KT00049	KT00049
GRUPPO TERMICO Ø 50 3 Travasi	CYLINDER KIT Ø 50 3 Ports	CYLINDRE COMPLET Ø 50 3 Transvasements		KT00012		KT00012	KT00012
GRUPPO TERMICO Ø 55 6 Travasi	CYLINDER KIT Ø 55 6 Ports	CYLINDRE COMPLET Ø 55 6 Transvasements		KT00014		KT00014	KT00014
GRUPPO TERMICO Ø 57 c/testa	CYLINDER KIT Ø 57 with cylinder head	CYLINDRE COMPLET Ø 57 avec culasse					
GRUPPO TERMICO Ø 60 c/testa	CYLINDER KIT Ø 60 with cylinder head	CYLINDRE COMPLET Ø 60 avec culasse					
GRUPPO TERMICO Ø 63 con testa	CYLINDER KIT Ø 63	CYLINDRE COMPLET Ø 63					
GRUPPO TERMICO Ø 69 Spinotto 18	CYLINDER KIT Ø 69 Pin 18	CYLINDRE COMPLET Ø 69 Axe de Piston Ø 18					
GRUPPO TERMICO Ø 69 Spinotto 16	CYLINDER KIT Ø 69 Pin 16	CYLINDRE COMPLET Ø 69 Axe de Piston Ø 16					
GRUPPO TERMICO Ø Maggiorato Alluminio	CYLINDER KIT BIG BORE Aluminium	CYLINDRE COMPLET Ø majoré aluminium					
INTERMITTENZA FRECCHE	FLASHER RELAY	RELAIS CLIGNOTANTS		ME00001			ME00001
KIT ASPIRAZIONE	INLET KIT	KIT ASPIRATION					
KIT CUSCINETTI BANCO	BEARINGS KIT	KIT PALIERS DE VILEBREQUIN		KK01012		KK01012	KK01012
MOLLE FRIZIONE	CLUTCH SPRINGS	RESSORTS EMBRAYAGE					ML00820
MOTORINO AVVIAMENTO	STARTER ENGINE	DÉMARREUR ÉLECTRIQUE		MA00023	MA00023	MA00023	MA00023
REGOLATORE DI TENSIONE	RECTIFIER	RÉGULATEUR DE TENSION		RE00008	RE00009	RE00009	RE00008
SCARICHI	EXHAUST	ÉCHAPPEMENT					
SERIE GUARNIZIONI MOTORE	ENGINE GASKET SET	JEU DE JOINTS MOTEUR		GR00741		GR00741	GR00741
SERIE PARAOLI BANCO	CRANKSHAFT OIL SEAL KIT	SÉRIE DE JOINTS DE BANC		K060100		K060100	K060100
SERIE PARAOLI MOTORE	ENGINE OIL SEAL KIT	SÉRIE DE JOINTS MOTEUR					
STATORE	STATOR	STATOR					

PIAGGIO	PIAGGIO	PIAGGIO	PIAGGIO	PIAGGIO	PIAGGIO	PIAGGIO	PIAGGIO	PIAGGIO	PIAGGIO	PIAGGIO	PIAGGIO
VESPA PK	VESPA PK	VESPA PK AUTOMATICA	VESPA PK XL	VESPA PK XL	VESPA PK XL PLURIMATIC	VESPA PK XL RUSH	VESPA PRIMAVERA	VESPA PX	VESPA PX	VESPA PX	VESPA PX
82-84	82-84	84-89	86-89	85-88	85-90	88-89	67-83	11-16	98-01	11-16	98-01
125cc 2T AC	50cc 2T AC	50cc 2T AC	125cc 2T AC	50cc 2T AC	50cc 2T AC	50cc 2T AC	125cc 2T AC	125cc 2T AC	125cc 2T AC	150cc 2T AC	150cc 2T AC
CI07498	CI07498		CI07498	CI07498		CI07498		CI07497	CI07497	CI07497	CI07497
	IM07005 IM07006	IM07007 IM07008		IM07007 IM07008		IM07007 IM07008	IM07067 IM07077	IM07068	IM07068	IM07068	IM07068
	IM07024	IM07024		IM07024		IM07024					
			CB03009								
CA00002		CA00002	CA00002		CA00002		CA00002	CA00002	CA00002	CA00002	CA00002
FZ00301 FZ00302 FZ00306	FZ00301 FZ00302 FZ00306		FZ00301 FZ00302 FZ00306	FZ00301 FZ00302 FZ00306		FZ00301 FZ00302 FZ00306	FZ00301 FZ00302 FZ00306	FZ00313	FZ00313		FZ00313
CP00212	CP00212	CP00212	CP00212		CP00212	CP00212		CP00212	CP00212		CP00212
	KT00010			KT00010		KT00010					
	KT00011			KT00011		KT00011					
	KT00013			KT00013		KT00013					
	KT00049			KT00049		KT00049					
	KT00012			KT00012		KT00012					
	KT00014			KT00014		KT00014					
							KT00015				
								KT00017	KT00017		KT00017
							KT00135	KT00136	KT00136		KT00136
	ME00001	ME00001	ME00001	ME00001		ME00001		ME00001	ME00001	ME00001	ME00001
								9932800	9932800	9932800	9932800
	KK01012			KK01012		KK01012	KK01015				
ML00820	ML00820		ML00820	ML00820		ML00820	ML00820	ML06181	ML06181		ML06181
	MA00023	MA00023		MA00023	MA00023	MA00023		MA00029	MA00029	MA00029	MA00029
			RE00008	RE00008	RE00010	RE00008		RE00008	RE00008	RE00008	RE00008
	MT00024			MT00024		MT00024	MT00002				
GR00743	GR00741		GR00743	GR00741		GR00741	GR00742	GR00744	GR00744	GR00744	GR00744
	K060100			K060100		K060100	K060040				
							K06004A	K060050	K060050	K060050	K060050
								ST00012	ST00012	ST00012	ST00012



PIAGGIO	PIAGGIO	PIAGGIO	PIAGGIO
VESPA PX	VESPA PX 30 ANNI	VESPA PX E (DEU)	VESPA PX E ARCOBALENO
98-01	07-08	81-97	81-97
200cc 2T AC	125cc 2T AC	80cc 2T AC	125cc 2T AC

IT	EN	FR				
ALBERI MESSA IN MOTO	KICK SHAFT	ARBRE DE DEMARREUR		CI07497	CI07497	CI07497
ALBERO MOTORE	CRANKSHAFT	VILEBREQUIN			IM07068	IM07068
BIELLA	CONROD	BIELLE				
CARBURATORE	CARBURETOR	CARBURATEUR				
CENTRALINA ACCENSIONE	CDI	Unité de contrôle		CA00002	CA00002	CA00002
CILINDRETTI FRENO	BRAKE CALLIPERS	CYLINDRES FREIN				
FRIZIONI	CLUTCH	EMBAYAGE			FZ00313	FZ00303 FZ00307
GANASCE FRENO	BRAKE SHOE	MÂCHOIRES FREIN		CP00212	CP00212	CP00212
GRUPPO TERMICO Ø Standard Spinotto 10	GRUPPO TERMICO Ø Standard pin 10	CYLINDRE COMPLET Ø Standard Axe de Piston Ø 10				
GRUPPO TERMICO Ø Standard Spinotto 12	CYLINDER KIT Ø Standard Pin 12	CYLINDRE COMPLET Ø Standard Axe de Piston Ø 12				
GRUPPO TERMICO Ø Maggiorato Spinotto 10	CYLINDER KIT BIG BORE pin 10	CYLINDRE COMPLET Ø majoré Axe de Piston Ø 10				
GRUPPO TERMICO Ø Maggiorato Spinotto 12	CYLINDER KIT BIG BORE pin 12	CYLINDRE COMPLET Ø majoré Axe de Piston Ø 12				
GRUPPO TERMICO Ø 47 3 Travasi	CYLINDER KIT Ø 47 3 Ports	CYLINDRE COMPLET Ø 47 3 Transvasements				
GRUPPO TERMICO Ø 47 6 Travasi	CYLINDER KIT Ø 47 6 Ports	CYLINDRE COMPLET Ø 47 6 Transvasements				
GRUPPO TERMICO Ø 47 10 Luci	CYLINDER KIT Ø 47 10 Ports	CYLINDRE COMPLET Ø 47 10 Ouvertures				
GRUPPO TERMICO Ø 50 3 Travasi	CYLINDER KIT Ø 50 3 Ports	CYLINDRE COMPLET Ø 50 3 Transvasements				
GRUPPO TERMICO Ø 55 6 Travasi	CYLINDER KIT Ø 55 6 Ports	CYLINDRE COMPLET Ø 55 6 Transvasements				
GRUPPO TERMICO Ø 57 c/testa	CYLINDER KIT Ø 57 with cylinder head	CYLINDRE COMPLET Ø 57 avec culasse				
GRUPPO TERMICO Ø 60 c/testa	CYLINDER KIT Ø 60 with cylinder head	CYLINDRE COMPLET Ø 60 avec culasse			KT00018	
GRUPPO TERMICO Ø 63 con testa	CYLINDER KIT Ø 63	CYLINDRE COMPLET Ø 63			KT00017	KT00017
GRUPPO TERMICO Ø 69 Spinotto 18	CYLINDER KIT Ø 69 Pin 18	CYLINDRE COMPLET Ø 69 Axe de Piston Ø 18				
GRUPPO TERMICO Ø 69 Spinotto 16	CYLINDER KIT Ø 69 Pin 16	CYLINDRE COMPLET Ø 69 Axe de Piston Ø 16				
GRUPPO TERMICO Ø Maggiorato Alluminio	CYLINDER KIT BIG BORE Aluminium	CYLINDRE COMPLET Ø majoré aluminium			KT00136	KT00136
INTERMITTENZA FRECCIE	FLASHER RELAY	RELAIS CLIGNOTANTS		ME00001	ME00001	ME00001
KIT ASPIRAZIONE	INLET KIT	KIT ASPIRATION		9932800	9932800	9932800
KIT CUSCINETTI BANCO	BEARINGS KIT	KIT PALIERS DE VILEBREQUIN				
MOLLE FRIZIONE	CLUTCH SPRINGS	RESSORTS EMBRAYAGE			ML06181	ML00821
MOTORINO AVVIAMENTO	STARTER ENGINE	DÉMARREUR ÉLECTRIQUE			MA00029	MA00029
REGOLATORE DI TENSIONE	RECTIFIER	RÉGULATEUR DE TENSION		RE00008	RE00008	RE00010
SCARICHI	EXHAUST	ÉCHAPPEMENT				
SERIE GUARNIZIONI MOTORE	ENGINE GASKET SET	JEU DE JOINTS MOTEUR		GR00745	GR00744	GR00744
SERIE PARAOLI BANCO	CRANKSHAFT OIL SEAL KIT	SÉRIE DE JOINTS DE BANC				
SERIE PARAOLI MOTORE	ENGINE OIL SEAL KIT	SÉRIE DE JOINTS MOTEUR		K060050	K060050	
STATORE	STATOR	STATOR		ST00012	ST00012	ST00012 ST00015

PIAGGIO	PIAGGIO	PIAGGIO	PIAGGIO	PIAGGIO
VESPA PX E ARCOBALENO	VESPA PX E ARCOBALENO	VESPA PX EU2	VESPA PX T5	VESPA SPECIAL-L-R
81-97	81-97	01-07	85-89	67-82
150cc 2T AC	200cc 2T AC	125cc 2T AC	125cc 2T AC	50cc 2T AC
CI07497	CI07497	CI07497		CI07498
IM07068		IM07068		IM07005 IM07006
				IM07024
				CB03008
CA00002	CA00002	CA00002	CA00002	CA00002
FZ00303 FZ00307	FZ00305 FZ00318	FZ00313	FZ00307	FZ00301 FZ00302 FZ00306
CP00212	CP00212	CP00212	CP00212	
				KT00010
				KT00011
				KT00013
				KT00049
				KT00012
				KT00014
KT00017		KT00017		
KT00136		KT00136		
ME00001	ME00001	ME00001	ME00001	
9932800	9932800	9932800		
				KK01011
ML00821		ML06181	ML00821	ML00820
MA00029	MA00029	MA00029		
RE00010	RE00010	RE00008	RE00010	
				MT00001
GR00744	GR00745	GR00744		GR00740
				K060040
		K060050	K060050	K06004A
ST00012 ST00015	ST00012 ST00015	ST00012		

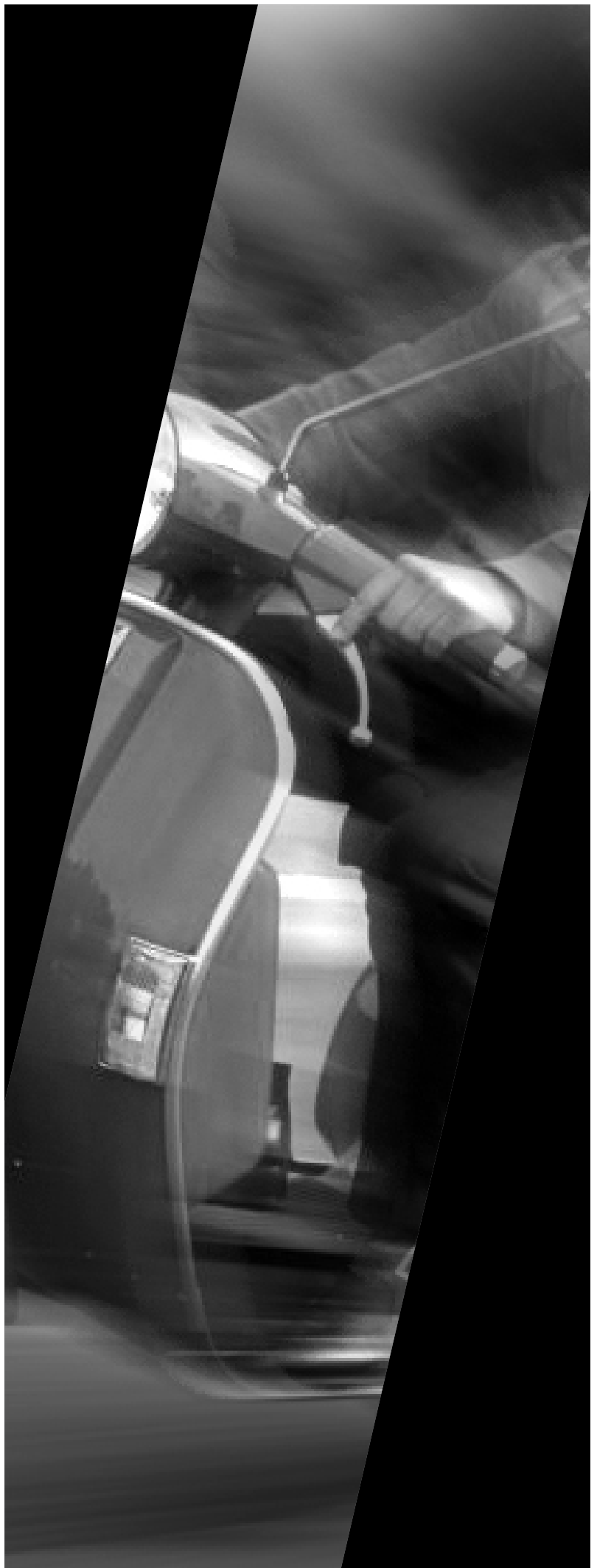

IT	ALTERNATORE	BOBINA	CENTRALINA	MOTORINO AVVIAMENTO	REGOLATORE	STATORE
EN	ALTERNATOR	COIL	CDI	STARTER ENGINE	RECTIFIER	STATOR
FR	ALTERNATEUR	BOBINE	BOÎTIER ÉLECTRONIQUE	DÉMARREUR ÉLECTRIQUE	RÉGULATEUR	STATOR
						

APRILIA	MODEL	YEAR	CC	TYPE	REMARKS	ALTERNATOR	COIL	CDI	STARTER ENGINE	RECTIFIER	STATOR
	ATLANTIC	03-05	125cc	4T LC					19588N		
	ATLANTIC	03-05	125cc	4T LC					37033N		
	ATLANTIC	01-04	500cc	4T LC					16073N		
	ATLANTIC EU3	06-08	125cc	4T LC					19588N		
	ATLANTIC EU3	06-08	125cc	4T LC	Piaggio				37033N		
	ATLANTIC EU3	10-12	125cc	4T LC					19588N		
	ATLANTIC EU3	10-12	125cc	4T LC	Piaggio				37033N		
	ATLANTIC SPRINT	05-08	400cc	4T LC	Piaggio M348M				16073N		
	ATLANTIC SPRINT	05-08	500cc	4T LC	Piaggio M273M				16073N		
	CLASSIC	00-05	125cc	2T					19628N		
	HABANA-MOJITO CUSTOM	99-03	50cc	2T AC	Motore Aprilia				37036N		
	HABANA-MOJITO RETRO'	99-03	50cc	2T AC	Motore Aprilia				37036N		
	LEONARDO	99-01	250cc	4T LC	Minarelli YP					B1001N	
	LEONARDO	02-04	250cc	4T LC	Minarelli YP					B1001N	
	LEONARDO ST	01-01	250cc	4T LC	Minarelli YP					B1001N	
	MOJITO	03-07	125cc	4T AC					19588N		
	MOJITO	03-07	125cc	4T AC	Leader				37033N		
	MOJITO	08-08	125cc	4T AC					19588N		
	MOJITO	08-08	125cc	4T AC	Piaggio				37033N		
	MOJITO CUSTOM 2T MOTORE PIAGGIO	04-10	50cc	2T AC	Motore Piaggio				19595N		
	MOTO' 6.5	95-99	650cc	4T LC						B1001N	
	PEGASO	92-96	650cc	4T					18820N	B1001N	
	PEGASO 3	97-00	650cc	4T					18820N	B1001N	
	PEGASO I.E.	01-04	650cc	4T					18820N	B1001N	
	PEGASO STRADA-FACTORY-TRAIL	05-09	660cc	4T					18760N		
	RS	96-05	125cc	2T					19628N		
	RS REPLICIA	01-05	125cc	2T					19628N		
	SCARABEO	99-03	125cc	4T					19571N		
	SCARABEO	03-03	125cc	4T LC					19588N		
	SCARABEO	03-03	125cc	4T LC	Piaggio				37033N		

IT	ALTERNATORE	BOBINA	CENTRALINA	MOTORINO AVVIAMENTO	REGOLATORE	STATORE
EN	ALTERNATOR	COIL	CDI	STARTER ENGINE	RECTIFIER	STATOR
FR	ALTERNATEUR	BOBINE	BOÎTIER ÉLECTRONIQUE	DÉMARREUR ÉLECTRIQUE	RÉGULATEUR	STATOR
						

APRILIA	Model	Year	Engine	Motor	Part	Code	Part	Code
	SCARABEO	04-06	125cc 4T LC			19588N		
	SCARABEO	04-06	125cc 4T LC	Piaggio		37033N		
	SCARABEO	99-03	150cc 4T			19571N		
	SCARABEO	03-06	500cc 4T LC	Piaggio		16073N		
	SCARABEO 2T EU2 MOTORE PIAGGIO	10-12	50cc 2T AC	Motore Piaggio		19595N		
	SCARABEO 2T NET	09-09	50cc 2T AC	Motore Piaggio		19595N		
	SCARABEO 2T NET	10-10	50cc 2T AC	Motore Piaggio		19595N		
	SCARABEO 4T	01-05	100cc 4T AC	Piaggio		16088N		
	SCARABEO 4T	10-12	100cc 4T AC	Piaggio		16088N		
	SCARABEO 4T	14-14	100cc 4T AC	Piaggio		16088N		
	SCARABEO 4T NET	09-09	100cc 4T AC	Piaggio		16088N		
	SCARABEO 4T NET EU3	10-10	100cc 4T AC	Piaggio		16088N		
	SCARABEO 4T RESTYLING	06-09	100cc 4T AC	Piaggio		16088N		
	SCARABEO DITECH	01-04	50cc 2T-IE AC	Motore Aprilia		37036N		
	SCARABEO EU3	06-07	125cc 4T LC			19588N		
	SCARABEO EU3	06-07	125cc 4T LC	Piaggio		37033N		
	SCARABEO LIGHT	06-08	400cc 4T LC	Piaggio		16073N		
	SCARABEO LIGHT	06-08	500cc 4T LC	Piaggio		16073N		
	SCARABEO STREET	05-06	50cc 2T AC	Motore Piaggio		19595N		
	SCARABEO STREET 2T RESTYLING	06-09	50cc 2T AC	Motore Piaggio		19595N		
	SPORT CITY	04-06	125cc 4T LC			19588N		
	SPORT CITY	04-06	125cc 4T LC	Piaggio M281M		37033N		
	SPORT CITY CUBE	08-10	125cc 4T LC			19588N		
	SPORT CITY CUBE	08-10	125cc 4T LC	Piaggio		37033N		
	SPORT CITY EU3	06-08	125cc 4T LC			19588N		
	SPORT CITY EU3	06-08	125cc 4T LC	Piaggio		37033N		
	SPORT CITY ONE 2T	08-11	50cc 2T AC	Motore Piaggio		19595N		
	SPORT CITY ONE 4T EU3	08-11	125cc 4T AC			19588N		
	SPORT CITY ONE 4T EU3	08-11	125cc 4T AC	Leader M38AM		37033N		
	SPORT CITY STREET	12-12	125cc 4T LC			19588N		

IT	ALTERNATORE	BOBINA	CENTRALINA	MOTORINO AVVIAMENTO	REGOLATORE	STATORE
EN	ALTERNATOR	COIL	CDI	STARTER ENGINE	RECTIFIER	STATOR
FR	ALTERNATEUR	BOBINE	BOÎTIER ÉLECTRONIQUE	DÉMARREUR ÉLECTRIQUE	RÉGULATEUR	STATOR
						

BRAND	MODEL	YEAR	CC	TYPE	PART NO.	
APRILIA	SPORT CITY STREET	12-12	125cc	4T LC	Piaggio	37033N
	SR DITECH EU2	02-04	50cc	2T-IE LC	Motore Aprilia	37036N
	SR H2O DITECH	00-04	50cc	2T-IE LC	Motore Aprilia	37036N
	SR MOTARD	12-14	50cc	2T LC	Motore Piaggio	19595N
	SR MOTARD	12-14	125cc	4T-2V AC		19588N
	SR MOTARD	12-14	125cc	4T-2V AC	Piaggio	37033N
	SR R FACTORY CARBURATORE	10-14	50cc	2T LC	Motore Piaggio	19595N
	SR R FACTORY Motore Aprilia	05-05	50cc	2T-IE LC	Motore Aprilia	37036N
	SR STREET CARBURATORE	03-12	50cc	2T LC	Motore Piaggio	19595N
	TUONO	03-05	125cc	2T		19628N
ARCTIC CAT	DVX 400	04-08	400cc	4T		18718N
	DVX 400 TS	06-07	400cc	4T		18718N
BENELLI	491 RR MORINI	03-04	50cc	2T LC	Motore Morini	37036N
	491 ST MORINI	03-03	50cc	2T AC	Motore Morini	37036N
	NAKED MORINI	03-04	50cc	2T AC	Motore Morini	37036N
BMW	C1	00-03	125cc	4T		19571N
	F	93-00	650cc	4T		18820N
	F CS / SCARVER	00-06	650cc	4T		18820N
	F CS ABS	03-05	650cc	4T		18820N
	F ENDURO	98-01	650cc	4T		18820N
	F FUNDURO	93-97	650cc	4T		18820N
	F GS	99-07	650cc	4T		18820N
	F GS	08-12	650cc	4T		18820N
	F GS DAKAR	01-07	650cc	4T		18820N
	F GS DAKOTA	00-07	650cc	4T		18820N
	F SE	99-99	650cc	4T		18820N
	F ST	97-99	650cc	4T		18820N
	F700GS	11-14	700cc	4T		18820N
	F800GS	08-14	800cc	4T		18820N
	F800GS ADVENTURE	12-14	800cc	4T		18820N

IT	ALTERNATORE	BOBINA	CENTRALINA	MOTORINO AVVIAMENTO	REGOLATORE	STATORE
EN	ALTERNATOR	COIL	CDI	STARTER ENGINE	RECTIFIER	STATOR
FR	ALTERNATEUR	BOBINE	BOÎTIER ÉLECTRONIQUE	DÉMARREUR ÉLECTRIQUE	RÉGULATEUR	STATOR
						

BMW	Model	Year	Capacity	Part No.	Part No.	Part No.	Part No.	Part No.	Part No.
	F800GT	11-14	800cc 4T				18820N		
	F800R	05-14	800cc 4T				18820N		
	F800S	06-08	800cc 4T				18820N		
	F800ST	06-08	800cc 4T				18820N		
	F800ST	09-12	800cc 4T				18820N		
	K 75	88-95	750cc 4T	12494N					
	K 75 C	85-90	750cc 4T	12494N					
	K 75 RT	90-95	750cc 4T	12494N					
	K 75 RT ABS	91-95	750cc 4T	12494N					
	K 75 S	86-95	750cc 4T	12494N					
	K 75 S ABS	91-95	750cc 4T	12494N					
	K GT	05-08	1200cc 4T				19646N		
	K GT	07-10	1300cc 4T				19646N		
	K GT	10-15	1600cc 4T				19646N		
	K GTL	10-15	1600cc 4T				19646N		
	K GTL EXCL	13-14	1600cc 4T				19646N		
	K R	04-08	1200cc 4T				19646N		
	K R	07-12	1300cc 4T				19646N		
	K R SPORT	05-08	1200cc 4T				19646N		
	K S	03-08	1200cc 4T				19646N		
	K S	07-15	1300cc 4T				19646N		
	K1100LT	92-97	1100cc 4T	12494N					
	K1100LT HIGH LINE	97-97	1100cc 4T	12494N					
	K1100LT SPECIAL EDITION	97-97	1100cc 4T	12494N					
	K1100RS	92-96	1100cc 4T	12494N					
	K1100RS SE	96-96	1100cc 4T	12494N					
	R 100	76-84	1000cc 4T				18915N		
	R 100 /7	76-78	1000cc 4T				18915N		
	R 100 /T, RT	78-84	1000cc 4T				18915N		
	R 100 CS	80-84	1000cc 4T				18915N		

IT	ALTERNATORE	BOBINA	CENTRALINA	MOTORINO AVVIAMENTO	REGOLATORE	STATORE
EN	ALTERNATOR	COIL	CDI	STARTER ENGINE	RECTIFIER	STATOR
FR	ALTERNATEUR	BOBINE	BOÎTIER ÉLECTRONIQUE	DÉMARREUR ÉLECTRIQUE	RÉGULATEUR	STATOR
						

BMW	Model	Year	Capacity	Part No.	Part No.	Part No.	Part No.	Part No.	Part No.
	R 100 GS	87-95	1000cc 4T				18915N		
	R 100 GS PARIS DAKAR	87-95	1000cc 4T				18915N		
	R 100 R	91-95	1000cc 4T				18915N		
	R 100 R CLASSIC - MYSTIC	94-96	1000cc 4T				18915N		
	R 100 RS	76-93	1000cc 4T				18915N		
	R 100 RT	78-95	1000cc 4T				18915N		
	R 100 S	76-80	1000cc 4T				18915N		
	R 45	78-85	450cc 4T				18915N		
	R 50 /5	69-73	500cc 4T				18915N		
	R 60 /6	73-76	600cc 4T				18915N		
	R 60 /7	76-80	600cc 4T				18915N		
	R 65	78-87	650cc 4T				18915N		
	R 65 LS	81-85	650cc 4T				18915N		
	R 75 /5	69-73	750cc 4T				18915N		
	R 75 /6	74-76	750cc 4T				18915N		
	R 75 /7	76-77	750cc 4T				18915N		
	R 80	84-95	800cc 4T				18915N		
	R 80 /7	77-80	800cc 4T				18915N		
	R 80 GS	80-96	800cc 4T				18915N		
	R 80 R	91-94	800cc 4T				18915N		
	R 80 RT	82-95	800cc 4T				18915N		
	R 80 ST	82-84	800cc 4T				18915N		
	R 90 /6	73-76	900cc 4T				18915N		
	R 90 S	73-76	900cc 4T				18915N		
	R1100GS	94-06	1100cc 4T	12494N					
	R1100GS ABS	95-99	1100cc 4T	12494N					
	R1100GS SE	99-99	1100cc 4T	12494N					
	R1100R	94-00	1100cc 4T	12494N					
	R1100R SE	99-99	1100cc 4T	12494N					
	R1100RL	01-01	1100cc 4T	12494N					

IT	ALTERNATORE	BOBINA	CENTRALINA	MOTORINO AVVIAMENTO	REGOLATORE	STATORE
EN	ALTERNATOR	COIL	CDI	STARTER ENGINE	RECTIFIER	STATOR
FR	ALTERNATEUR	BOBINE	BOÎTIER ÉLECTRONIQUE	DÉMARREUR ÉLECTRIQUE	RÉGULATEUR	STATOR
						

BMW	R1100RS	92-01	1100cc 4T		12494N					
	R1100RS ABS	95-99	1100cc 4T		12494N					
	R1100RSL	94-96	1100cc 4T		12494N					
	R1100RT	94-01	1100cc 4T		12494N					
	R1100RT SE	00-00	1100cc 4T		12494N					
	R1100RTL	96-97	1100cc 4T		12494N					
	R1100S	98-05	1100cc 4T		12494N					
	R1150GS	99-04	1150cc 4T		12494N					
	R1150GS ADVENTURE	01-05	1150cc 4T		12494N					
	R1150R	01-06	1150cc 4T		12494N					
	R1150R ROADSTER	02-06	1150cc 4T		12494N					
	R1150RS	00-04	1150cc 4T		12494N					
	R1150RT	00-05	1150cc 4T		12494N					
	R1200C	98-03	1200cc 4T		12494N					
	R1200C AVANTGARDE	00-03	1200cc 4T		12494N					
	R1200C CLASSIC	96-03	1200cc 4T		12494N					
	R1200C EURO	98-02	1200cc 4T		12494N					
	R1200C INDEPENDENT	00-03	1200cc 4T		12494N					
	R1200C MONTANA	00-03	1200cc 4T		12494N					
	R1200C PHOENIX	00-02	1200cc 4T		12494N					
R1200C STILETTO	01-01	1200cc 4T		12494N						
R850C CLASSIC	98-00	850cc 4T		12494N						
R850R	95-01	850cc 4T		12494N						
R850R ABS	96-96	850cc 4T		12494N						
R850R SPECIAL EDITION	97-97	850cc 4T		12494N						
R850RT	02-06	850cc 4T		12494N						
BOBCAT	2200S	04-06	720cc 4T				19162N			
BOMBARDIER	DS650	00-07	650cc 4T				18820N			
	DS650 BAJA	01-04	650cc 4T				18820N			
	DS650 X	04-07	650cc 4T				18820N			

IT	ALTERNATORE	BOBINA	CENTRALINA	MOTORINO AVVIAMENTO	REGOLATORE	STATORE
EN	ALTERNATOR	COIL	CDI	STARTER ENGINE	RECTIFIER	STATOR
FR	ALTERNATEUR	BOBINE	BOÎTIER ÉLECTRONIQUE	DÉMARREUR ÉLECTRIQUE	RÉGULATEUR	STATOR
						

CAN-AM	DS650 X	07-07	650cc 4T				18820N		
	DERBI	ATLANTIS 4T	04-06	100cc 4T AC	Piaggio			16088N	
BOULEVARD		02-02	125cc 4T AC				19588N		
	BOULEVARD	02-02	125cc 4T AC	Leader			37033N		
	BOULEVARD	03-04	125cc 4T AC				19588N		
	BOULEVARD	03-04	125cc 4T AC	Piaggio			37033N		
	BOULEVARD	02-02	150cc 4T AC				19588N		
	BOULEVARD	02-02	150cc 4T AC	Leader			37033N		
	BOULEVARD	03-04	150cc 4T AC				19588N		
	BOULEVARD	03-04	150cc 4T AC	Piaggio			37033N		
	BOULEVARD 4T	10-11	100cc 4T AC	Piaggio			16088N		
	BOULEVARD 4T E3	10-10	150cc 4T AC				19588N		
	BOULEVARD 4T E3	10-10	150cc 4T AC	Piaggio			37033N		
	BOULEVARD 4T EU3	08-12	125cc 4T AC				19588N		
	BOULEVARD 4T EU3	08-12	125cc 4T AC	Piaggio			37033N		
	BOULEVARD EU2	04-07	125cc 4T AC				19588N		
	BOULEVARD EU2	04-07	125cc 4T AC	Piaggio			37033N		
	BOULEVARD EU2	05-06	200cc 4T AC				19588N		
	BOULEVARD EU2	05-06	200cc 4T AC	Piaggio M387M			37033N		
	BOULEVARD EU3	04-07	150cc 4T AC				19588N		
	BOULEVARD EU3	04-07	150cc 4T AC	Piaggio			37033N		
	GP1 EU 2	06-06	125cc 4T LC				19588N		
	GP1 EU 2	06-06	125cc 4T LC				37033N		
	GP1 LOW SEAT EU3	07-08	125cc 4T LC				19588N		
	GP1 LOW SEAT EU3	07-08	125cc 4T LC	Piaggio			37033N		
	RAMBLA	08-09	125cc 4T LC				19588N		
	RAMBLA	08-09	125cc 4T LC	Piaggio M287M			37033N		
	RAMBLA EU3 2VER	08-08	125cc 4T LC				19588N		
	RAMBLA EU3 2VER	08-08	125cc 4T LC	Piaggio			37033N		
	SONAR 4T	09-11	125cc 4T AC				19588N		

IT	ALTERNATORE	BOBINA	CENTRALINA	MOTORINO AVVIAMENTO	REGOLATORE	STATORE
EN	ALTERNATOR	COIL	CDI	STARTER ENGINE	RECTIFIER	STATOR
FR	ALTERNATEUR	BOBINE	BOÎTIER ÉLECTRONIQUE	DÉMARREUR ÉLECTRIQUE	RÉGULATEUR	STATOR
						

DERBI	Model	Year	Engine	Brand	Part No.	Part No.	Part No.	Part No.	Part No.	Part No.
	SONAR 4T	09-11	125cc 4T AC	Piaggio				37033N		
	SONAR 4T	09-09	150cc 4T AC					19588N		
	SONAR 4T	09-09	150cc 4T AC	Piaggio				37033N		
	VARIANT SPORT 4T EU3	12-12	125cc 4T AC					19588N		
	VARIANT SPORT 4T EU3	12-12	125cc 4T AC	Motore Piaggio				37033N		
DUCATI	1098	07-08	1098cc 4T					19876N		
	1098 S	07-08	1098cc 4T					19876N		
	1098 S TRICOLORE	07-07	1098cc 4T					19876N		
	748	00-03	748cc 4T					19876N		
	748 R	00-02	748cc 4T					19876N		
	748 R MONOPOSTO	01-02	748cc 4T					19876N		
	748 S	00-02	748cc 4T					19876N		
	749	03-06	748cc 4T					19876N		
	749 DARK	04-06	748cc 4T					19876N		
	749 R	04-06	748cc 4T					19876N		
	749 S	03-06	748cc 4T					19876N		
	916 SP	95-95	916cc 4T					19876N		
	916 SPS	97-98	916cc 4T					19876N		
	996	02-02	996cc 4T					19876N		
	996 BIPOSTO	01-01	996cc 4T					19876N		
	996 MONOPOSTO	01-01	996cc 4T					19876N		
	996 R	01-01	996cc 4T					19876N		
	996 S	01-03	996cc 4T					19876N		
	996 SPS	99-00	996cc 4T					19876N		
	998 MATRIX	04-04	998cc 4T					19876N		
	998 R	02-02	998cc 4T					19876N		
	998 S	02-02	998cc 4T					19876N		
	998 S BAYLISS	02-02	998cc 4T					19876N		
	998 S BOSTROM	02-02	998cc 4T					19876N		
	999	03-06	999cc 4T					19876N		

IT	ALTERNATORE	BOBINA	CENTRALINA	MOTORINO AVVIAMENTO	REGOLATORE	STATORE
EN	ALTERNATOR	COIL	CDI	STARTER ENGINE	RECTIFIER	STATOR
FR	ALTERNATEUR	BOBINE	BOÎTIER ÉLECTRONIQUE	DÉMARREUR ÉLECTRIQUE	RÉGULATEUR	STATOR
						

DUCATI								
	999 R	03-06	998cc 4T				19876N	
	999 R FILA	03-04	998cc 4T				19876N	
	999 R XEROX	06-06	998cc 4T				19876N	
	999 S	03-06	998cc 4T				19876N	
	MONSTER	01-05	400cc 4T				19876N	
	MONSTER	00-01	600cc 4T				19876N	
	MONSTER	02-06	620cc 4T				19876N	
	MONSTER	04-04	620cc 4T				19876N	
	MONSTER	07-08	695cc 4T				19876N	
	MONSTER	08-09	696cc 4T				19876N	
	MONSTER	99-02	750cc 4T				19876N	
	MONSTER	00-02	750cc 4T				19876N	
	MONSTER	03-04	800cc 4T				19876N	
	MONSTER	04-04	800cc 4T				19876N	
	MONSTER	97-02	900cc 4T				19876N	
	MONSTER	00-02	900cc 4T				19876N	
	MONSTER	03-05	1000cc 4T				19876N	
	MONSTER	04-05	1000cc 4T				19876N	
	MONSTER CAPIREX	04-04	620cc 4T				19876N	
	MONSTER CROMO	01-01	900cc 4T				19876N	
	MONSTER DARK	02-04	400cc 4T				19876N	
	MONSTER DARK	01-01	600cc 4T				19876N	
	MONSTER DARK	05-06	620cc 4T				19876N	
	MONSTER DARK	01-02	750cc 4T				19876N	
	MONSTER DARK	03-03	800cc 4T				19876N	
	MONSTER DARK	01-02	900cc 4T				19876N	
	MONSTER DARK	03-03	1000cc 4T				19876N	
	MONSTER METALLIC	01-01	400cc 4T				19876N	
	MONSTER METALLIC	01-01	600cc 4T				19876N	
	MONSTER S	03-03	400cc 4T				19876N	

IT	ALTERNATORE	BOBINA	CENTRALINA	MOTORINO AVVIAMENTO	REGOLATORE	STATORE
EN	ALTERNATOR	COIL	CDI	STARTER ENGINE	RECTIFIER	STATOR
FR	ALTERNATEUR	BOBINE	BOÎTIER ÉLECTRONIQUE	DÉMARREUR ÉLECTRIQUE	RÉGULATEUR	STATOR
						

DUCATI	Model	Year	Capacity	Part Number	Part Number	Part Number	Part Number	Part Number	Part Number
	MONSTER S	02-03	620cc 4T				19876N		
	MONSTER S	03-03	800cc 4T				19876N		
	MONSTER S	00-01	900cc 4T				19876N		
	MONSTER S	03-05	1000cc 4T				19876N		
	MONSTER S2R	05-06	800cc 4T				19876N		
	MONSTER S2R	07-07	800cc 4T				19876N		
	MONSTER S2R	06-08	1000cc 4T				19876N		
	MONSTER S2R DARK	05-06	800cc 4T				19876N		
	MONSTER S4	01-02	916cc 4T				19876N		
	MONSTER S4R	05-06	996cc 4T				19876N		
	MONSTER S4R	07-08	1000cc 4T				19876N		
	MONSTER S4RS	06-06	1000cc 4T				19876N		
	MONSTER S4RS	06-08	1000cc 4T				19876N		
	MONSTER S4RS TRICOLORE	08-08	1000cc 4T				19876N		
	MULTISTRADA	05-06	620cc 4T				19876N		
	MULTISTRADA	03-05	1000cc 4T				19876N		
	MULTISTRADA	07-08	1100cc 4T				19876N		
	MULTISTRADA DARK	05-06	620cc 4T				19876N		
	MULTISTRADA DS	05-06	1000cc 4T				19876N		
	MULTISTRADA S	07-09	1100cc 4T				19876N		
	MULTISTRADA S DS	05-06	1000cc 4T				19876N		
	SPORCLASSIC PAUL SMART	05-06	1000cc 4T				19876N		
	SPORT	01-02	750cc 4T				19876N		
	SPORT	03-03	800cc 4T				19876N		
	SPORT	02-02	900cc 4T				19876N		
	SPORT	06-06	1000cc 4T				19876N		
	SPORT BIPOSTO	07-08	1000cc 4T				19876N		
	SPORT MONOPOSTO	07-07	1000cc 4T				19876N		
	SPORT TOURING ST2	00-03	1000cc 4T				19876N		
	SPORT TOURING ST3	04-07	1000cc 4T				19876N		

IT	ALTERNATORE	BOBINA	CENTRALINA	MOTORINO AVVIAMENTO	REGOLATORE	STATORE
EN	ALTERNATOR	COIL	CDI	STARTER ENGINE	RECTIFIER	STATOR
FR	ALTERNATEUR	BOBINE	BOÎTIER ÉLECTRONIQUE	DÉMARREUR ÉLECTRIQUE	RÉGULATEUR	STATOR
						

BRAND	MODEL	YEAR	CC	TYPE	ITEM	ITEM	ITEM	ITEM	ITEM	ITEM
DUCATI	SPORT TOURING ST3 S ABS	06-07	1000cc	4T				19876N		
	SPORT TOURING ST4	00-03	916cc	4T				19876N		
	SPORT TOURING ST4	04-04	916cc	4T				19876N		
	SPORT TOURING ST4S	01-05	996cc	4T				19876N		
	SPORT TOURING ST4S	04-04	996cc	4T				19876N		
	SPORT TOURING ST4S ABS	05-05	996cc	4T				19876N		
	SPORTCLASSIC GT	07-10	1000cc	4T				19876N		
	SPORTCLASSIC GT TOURING	09-09	1000cc	4T				19876N		
	SPORTCLASSIC MH900E	01-02	900cc	4T				19876N		
	SPORTCLASSIC SPORT S	07-08	1000cc	4T				19876N		
GILERA	SUPERSPORT S	03-03	620cc	4T				19876N		
	DNA	01-01	125cc	4T LC				19588N		
	DNA	01-01	125cc	4T LC	Piaggio			37033N		
	DNA	01-01	180cc	4T LC				19588N		
	DNA	01-01	180cc	4T LC	Piaggio			37033N		
	FUOCO 4T-4V IE E3 LT	13-14	500cc	4T LC	Piaggio			16073N		
	FUOCO IE EU3	07-13	500cc	4T LC	Piaggio			16073N		
	NEXUS	03-05	500cc	4T LC	Piaggio			16073N		
	NEXUS EU3	07-08	125cc	4T LC				19588N		
	NEXUS EU3	07-08	125cc	4T LC	Piaggio			37033N		
	NEXUS EU3	06-08	500cc	4T LC	Piaggio			16073N		
	NEXUS EU3	09-11	500cc	4T LC	Piaggio			16073N		
	NEXUS SP EU3	06-07	500cc	4T LC	Piaggio			16073N		
	RUNNER 4T ST EU3	08-16	125cc	4T LC				19588N		
	RUNNER 4T ST EU3	08-16	125cc	4T LC	Piaggio			37033N		
	RUNNER FXR	97-02	180cc	2T LC	Piaggio			16088N		
	RUNNER VX	00-01	125cc	4T LC				19588N		
	RUNNER VX	00-01	125cc	4T LC	Piaggio			37033N		
	RUNNER VX	02-04	125cc	4T LC				19588N		
	RUNNER VX	02-04	125cc	4T LC	Piaggio			37033N		

IT	ALTERNATORE	BOBINA	CENTRALINA	MOTORINO AVVIAMENTO	REGOLATORE	STATORE
EN	ALTERNATOR	COIL	CDI	STARTER ENGINE	RECTIFIER	STATOR
FR	ALTERNATEUR	BOBINE	BOÎTIER ÉLECTRONIQUE	DÉMARREUR ÉLECTRIQUE	RÉGULATEUR	STATOR
						

GILERA	Model	Year	Engine	Brand	Part Numbers					
					IT	EN	FR	IT	EN	FR
GILERA	RUNNER VX	05-06	125cc 4T LC					19588N		
	RUNNER VX	05-06	125cc 4T LC	Piaggio				37033N		
	RUNNER VX 4T EU3	06-07	125cc 4T LC					19588N		
	RUNNER VX 4T EU3	06-07	125cc 4T LC	Piaggio				37033N		
	RUNNER VX RACE	06-06	125cc 4T LC					19588N		
	RUNNER VX RACE	06-06	125cc 4T LC	Piaggio				37033N		
	RUNNER VX SC	06-07	125cc 4T LC					19588N		
	RUNNER VX SC	06-07	125cc 4T LC	Piaggio				37033N		
	RUNNER VXR	00-01	180cc 4T LC					19588N		
	RUNNER VXR	00-01	180cc 4T LC	Piaggio				37033N		
	RUNNER VXR	02-04	200cc 4T LC					19588N		
	RUNNER VXR	02-04	200cc 4T LC	Piaggio				37033N		
	RUNNER VXR	05-06	200cc 4T LC					19588N		
	RUNNER VXR	05-06	200cc 4T LC	Piaggio				37033N		
	RUNNER VXR 4T ST EU3	08-11	200cc 4T LC					19588N		
	RUNNER VXR 4T ST EU3	08-11	200cc 4T LC	Piaggio				37033N		
	RUNNER VXR EU3	07-07	200cc 4T LC					19588N		
	RUNNER VXR EU3	07-07	200cc 4T LC	Piaggio				37033N		
	RUNNER VXR RACE 200	06-06	125cc 4T LC					19588N		
	RUNNER VXR RACE 200	06-06	125cc 4T LC	Piaggio				37033N		
GMI	GMI 101	04-08	50cc 4T AC					19597N		
	GMI 102	04-08	50cc 4T AC					19597N		
	GMI 102P	04-08	50cc 4T AC					19597N		
	GMI 103	04-08	50cc 4T AC					19597N		
	GMI 104	04-08	50cc 4T AC					19597N		
	GMI 106	04-08	50cc 4T AC					19597N		
	GMI 106I	04-08	50cc 4T AC					19597N		
	GMI 107	04-08	50cc 4T AC					19597N		
	GMI 107XP	04-08	50cc 4T AC					19597N		
	GMI 108	04-08	50cc 4T AC					19597N		

IT	ALTERNATORE	BOBINA	CENTRALINA	MOTORINO AVVIAMENTO	REGOLATORE	STATORE
EN	ALTERNATOR	COIL	CDI	STARTER ENGINE	RECTIFIER	STATOR
FR	ALTERNATEUR	BOBINE	BOÎTIER ÉLECTRONIQUE	DÉMARREUR ÉLECTRIQUE	RÉGULATEUR	STATOR
						

GMI	GMI 109	04-08	50cc 4T AC				19597N		
	GMI 110	04-08	50cc 4T AC				19597N		
	GMI 111	04-08	50cc 4T AC				19597N		
	GMI 301	04-08	50cc 4T AC				19597N		
	GMI 304	04-08	50cc 4T AC				19597N		
HARLEY DAVIDSON	FL	41-64	1200cc 4T				5780BN 5780CN		
	FL SERIES (PRE 1977)	65-69	1200cc 4T AC				15410BN		
	FL SERIES (PRE 1977)	65-76	1200cc 4T				5780BN 5780CN		
	FLD SWITCHBACK	12-14	1690cc 4T					H3108 H3108C	
	FLF	53-64	1200cc 4T				5780CN		
	FLF	54-64	1200cc 4T				5780BN		
	FLFB	65-69	1200cc 4T				15410BN		
	FLFB	65-69	1200cc 4T				5780BN 5780CN		
	FLH ELECTRA GLIDE	55-78	1200cc 4T				5780BN 5780CN		
	FLH ELECTRA GLIDE	70-75	1200cc 4T					H1070 H1070C	
	FLH ELECTRA GLIDE	76-80	1340cc 4T					H1075 H1075C	
	FLH ELECTRA GLIDE	79-83	1340cc 4T				5780BN 5780CN		
	FLH ELECTRA GLIDE	81-85	1340cc 4T					H1686	
	FLH ELECTRA GLIDE	84-85	1340cc 4T				18300BN 18300CN		
	FLHB	65-69	1200cc 4T				15410BN		
	FLHB	65-69	1200cc 4T				5780BN 5780CN		
	FLHC ELECTRA GLIDE CLASSIC	79-81	1340cc 4T				5780BN 5780CN		
	FLHC ELECTRA GLIDE CLASSIC	80-80	1340cc 4T				18300BN 18300CN		
	FLHC ELECTRA GLIDE CLASSIC	81-81	1340cc 4T					H1686	
	FLHF	55-72	1200cc 4T				5780BN 5780CN		
FLHF	70-72	1200cc 4T					H1070 H1070C		
FLHFB	65-69	1200cc 4T				5780BN 5780CN			
FLHP ROAD KING	07-07	1690cc 4T					H0506		
FLHP ROAD KING	11-14	1690cc 4T					H0505 H0505C		
FLHR ROAD KING	94-98	1340cc 4T				18446CN 18446N	18199BN 18199N		

IT	ALTERNATORE	BOBINA	CENTRALINA	MOTORINO AVVIAMENTO	REGOLATORE	STATORE
EN	ALTERNATOR	COIL	CDI	STARTER ENGINE	RECTIFIER	STATOR
FR	ALTERNATEUR	BOBINE	BOÎTIER ÉLECTRONIQUE	DÉMARREUR ÉLECTRIQUE	RÉGULATEUR	STATOR
						

HARLEY DAVIDSON	Model	Year	Capacity	Part Number		Voltage	Part Name	
				Part Number	Part Name			
FLHR ROAD KING	99-99	1450cc 4T		18446N				
				18446CN 18199BN 18199N				
FLHR ROAD KING	06-06	1450cc 4T					H0506	
FLHR ROAD KING	07-07	1584cc 4T				18905BN 18905CN	H0506C	
FLHR ROAD KING	07-08	1584cc 4T					H0506 H0506C	
FLHR ROAD KING	09-11	1584cc 4T					H0505 H0505C	
FLHR ROAD KING	12-13	1690cc 4T					H0505C	
FLHRC ROAD KING CLASSIC	07-07	1584cc 4T				18905BN 18905CN		
FLHRC ROAD KING CLASSIC	07-08	1584cc 4T					H0506 H0506C	
FLHRC ROAD KING CLASSIC	09-10	1584cc 4T					H0505 H0505C	
FLHRC ROAD KING CLASSIC	11-13	1690cc 4T					H0505 H0505C	
FLHRCI ROAD KING CLASSIC	98-98	1340cc 4T				18199N 18446CN 18446N	18199BN 18199CN	H1988 H1988C
FLHRCI ROAD KING CLASSIC	99-01	1450cc 4T						H0597 H0597C
FLHRCI ROAD KING CLASSIC	99-06	1450cc 4T				18199N 18446CN 18446N	18199BN 18199CN	
FLHRCI ROAD KING CLASSIC	02-02	1450cc 4T						H0502 H0502C
FLHRCI ROAD KING CLASSIC	06-08	1450cc 4T						H0506 H0506C
FLHRCI ROAD KING CLASSIC	07-07	1450cc 4T				18905BN 18905CN		
FLHRCI ROAD KING CLASSIC	03-03	1690cc 4T				18199N		
FLHRI ROAD KING	96-97	1340cc 4T						H1988 H1988C
FLHRI ROAD KING	96-06	1450cc 4T				18199N 18446CN 18446N	18199BN 18199CN	
FLHRI ROAD KING	00-01	1450cc 4T						H0597 H0597C
FLHRI ROAD KING	02-03	1450cc 4T						H0502 H0502C
FLHRI ROAD KING	06-08	1450cc 4T						H0506 H0506C
FLHRI ROAD KING	07-07	1584cc 4T				18905BN 18905CN		
FLHRS ROAD KING CUSTOM	04-06	1450cc 4T				18446CN 18446N	18199BN 18199N	
FLHRS ROAD KING CUSTOM	06-07	1584cc 4T						H0506 H0506C
FLHRS ROAD KING CUSTOM	07-07	1584cc 4T				18905BN 18905CN		
FLHRSE3 SCREAMIN EAGLE ROAD KING	07-07	1800cc 4T				18905BN 18905CN		
FLHRSE4 SCREAMIN EAGLE ROAD KING	08-08	1584cc 4T				18905BN 18905CN	H0506 H0506C	
FLHRSE4 SCREAMIN EAGLE ROAD KING	08-08	1800cc 4T				18905BN 18905CN		

IT	ALTERNATORE	BOBINA	CENTRALINA	MOTORINO AVVIAMENTO	REGOLATORE	STATORE
EN	ALTERNATOR	COIL	CDI	STARTER ENGINE	RECTIFIER	STATOR
FR	ALTERNATEUR	BOBINE	BOÎTIER ÉLECTRONIQUE	DÉMARREUR ÉLECTRIQUE	RÉGULATEUR	STATOR
						

HARLEY DAVIDSON	Model	Year	Engine	Part Number	Part Number	Part Number	Part Number	Part Number	Part Number
	FLHRSES CVO ROAD KING	13-13	1800cc 4T				18905BN		
	FLHRSEI SCREAMIN EAGLE ROAD KING	02-02	1550cc 4T				18199N 18446CN 18446N	18199BN 18199CN	
	FLHRSI ROAD KING CUSTOM	04-06	1450cc 4T				18199N 18446CN 18446N	18199BN 18199CN	
	FLHRSI ROAD KING CUSTOM	06-06	1450cc 4T					H0506 H0506C	
	FLHS ELECTRA GLIDE SPORT	80-81	1340cc 4T				5780BN 5780CN		
	FLHS ELECTRA GLIDE SPORT	81-88	1340cc 4T					H1686	
	FLHS ELECTRA GLIDE SPORT	84-88	1340cc 4T				18300BN 18300CN		
	FLHS ELECTRA GLIDE SPORT	89-90	1340cc 4T				17629BN 17629CN		
	FLHS ELECTRA GLIDE SPORT	89-93	1340cc 4T					H1988 H1988C	
	FLHS ELECTRA GLIDE SPORT	91-93	1340cc 4T				17629CN-HT 17629N	17629BN 17629CN	
	FLHT ELECTRA GLIDE STANDARD	86-87	1340cc 4T				18300BN 18300CN		
	FLHT ELECTRA GLIDE STANDARD	95-98	1340cc 4T				18199N 18446CN 18446N	18199BN 18199CN	
	FLHT ELECTRA GLIDE STANDARD	99-06	1450cc 4T				18199N 18446CN 18446N	18199BN 18199CN	
	FLHT ELECTRA GLIDE STANDARD	06-08	1584cc 4T					H0506 H0506C	
	FLHT ELECTRA GLIDE STANDARD	07-07	1584cc 4T				18905BN 18905CN		
	FLHT ELECTRA GLIDE STANDARD	09-09	1584cc 4T					H0505 H0505C	
	FLHTC ELECTRA GLIDE CLASSIC	83-88	1340cc 4T				18300BN 18300CN		
	FLHTC ELECTRA GLIDE CLASSIC	89-90	1340cc 4T				17629BN 17629CN		
	FLHTC ELECTRA GLIDE CLASSIC	91-93	1340cc 4T				17629CN-HT 17629N	17629BN 17629CN	
	FLHTC ELECTRA GLIDE CLASSIC	94-98	1340cc 4T				18446CN 18446N	18199BN 18199N	
	FLHTC ELECTRA GLIDE CLASSIC	99-05	1450cc 4T				18446CN 18446N	18199BN 18199N	
	FLHTC ELECTRA GLIDE CLASSIC	07-07	1584cc 4T				18905BN 18905CN		
	FLHTC ELECTRA GLIDE CLASSIC	07-08	1584cc 4T					H0506 H0506C	
	FLHTC ELECTRA GLIDE CLASSIC	09-11	1584cc 4T					H0505 H0505C	
	FLHTC ELECTRA GLIDE CLASSIC	12-13	1690cc 4T					H0505 H0505C	
	FLHTCI ELECTRA GLIDE CLASSIC	83-88	1340cc 4T				18300BN 18300CN	H1686	
	FLHTCI ELECTRA GLIDE CLASSIC	89-90	1340cc 4T				17629BN 17629CN		
	FLHTCI ELECTRA GLIDE CLASSIC	89-96	1340cc 4T					H1988 H1988C	
	FLHTCI ELECTRA GLIDE CLASSIC	91-93	1340cc 4T				17629CN-HT 17629N	17629BN 17629CN	
	FLHTCI ELECTRA GLIDE CLASSIC	94-98	1340cc 4T				18199N 18446CN 18446N	18199BN 18199CN	

IT	ALTERNATORE	BOBINA	CENTRALINA	MOTORINO AVVIAMENTO	REGOLATORE	STATORE
EN	ALTERNATOR	COIL	CDI	STARTER ENGINE	RECTIFIER	STATOR
FR	ALTERNATEUR	BOBINE	BOÎTIER ÉLECTRONIQUE	DÉMARREUR ÉLECTRIQUE	RÉGULATEUR	STATOR
						

HARLEY DAVIDSON	Part Description	Year	Capacity	Part Number	Part Number	Part Number	Part Number	Part Number	Part Number
HARLEY DAVIDSON	FLHTCI ELECTRA GLIDE CLASSIC	96-06	1450cc 4T				18199BN 18446CN 18446N		
	FLHTCI ELECTRA GLIDE CLASSIC	97-01	1450cc 4T					H0597 H0597C	
	FLHTCI ELECTRA GLIDE CLASSIC	99-06	1450cc 4T				18199CN 18199N		
	FLHTCI ELECTRA GLIDE CLASSIC	06-08	1450cc 4T					H0506 H0506C	
	FLHTCI ELECTRA GLIDE CLASSIC	07-07	1584cc 4T				18905BN 18905CN		
	FLHTCU ELECTRA GLIDE ULTRA CLASSIC	89-90	1340cc 4T				17629BN 17629CN		
	FLHTCU ELECTRA GLIDE ULTRA CLASSIC	91-93	1340cc 4T				17629CN-HT 17629N	17629BN 17629CN	
	FLHTCU ELECTRA GLIDE ULTRA CLASSIC	94-97	1340cc 4T				18446CN 18446N	18199BN 18199N	
	FLHTCU ELECTRA GLIDE ULTRA CLASSIC	07-08	1584cc 4T					H0506 H0506C	
	FLHTCU ELECTRA GLIDE ULTRA CLASSIC	09-11	1584cc 4T					H0505 H0505C	
	FLHTCU ELECTRA GLIDE ULTRA CLASSIC	12-13	1690cc 4T					H0505 H0505C	
	FLHTCUI ELECTRA GLIDE ULTRA CLASSIC	89-90	1340cc 4T				17629BN 17629CN		
	FLHTCUI ELECTRA GLIDE ULTRA CLASSIC	89-96	1340cc 4T					H1988 H1988C	
	FLHTCUI ELECTRA GLIDE ULTRA CLASSIC	91-93	1340cc 4T				17629CN-HT 17629N	17629BN 17629CN	
	FLHTCUI ELECTRA GLIDE ULTRA CLASSIC	94-94	1340cc 4T				18446CN		
	FLHTCUI ELECTRA GLIDE ULTRA CLASSIC	94-98	1340cc 4T				18446N		
	FLHTCUI ELECTRA GLIDE ULTRA CLASSIC	95-98	1450cc 4T				18446CN		
	FLHTCUI ELECTRA GLIDE ULTRA CLASSIC	95-06	1450cc 4T				18199BN 18199CN 18199N		
	FLHTCUI ELECTRA GLIDE ULTRA CLASSIC	97-01	1450cc 4T					H0597 H0597C	
	FLHTCUI ELECTRA GLIDE ULTRA CLASSIC	99-06	1450cc 4T				18446CN 18446N		
	FLHTCUI ELECTRA GLIDE ULTRA CLASSIC	06-06	1450cc 4T					H0506	
	FLHTCUI ELECTRA GLIDE ULTRA CLASSIC	06-08	1584cc 4T					H0506C	
	FLHTCUI ELECTRA GLIDE ULTRA CLASSIC	07-08	1584cc 4T					H0506	
	FLHTCUSE2 SCREAMIN EAGLE ULTRA CLASSIC ELECTRA GLI	07-07	1800cc 4T				18905BN 18905CN		
	FLHTCUSE3 SCREAMIN EAGLE ULTRA CLASSIC ELECTRA GLI	08-08	1800cc 4T				18905BN 18905CN		
	FLHTCUSE4 CVO ULTRA CLASSIC ELECTRA GLIDE	09-09	1584cc 4T				18905BN 18905CN		
	FLHTCUSE5 CVO ULTRA CLASSIC ELECTRA GLIDE	10-10	1584cc 4T				18905BN 18905CN		
	FLHTCUSE6 CVO ULTRA CLASSIC ELECTRA GLIDE	11-11	1800cc 4T				18905BN 18905CN		
	FLHTCUSE7 CVO ULTRA CLASSIC ELECTRA GLIDE	12-12	1800cc 4T				18905BN 18905CN		
	FLHTCUSE8 CVO ULTRA CLASSIC ELECTRA GLIDE	13-13	1800cc 4T				18905BN 18905CN		

IT	ALTERNATORE	BOBINA	CENTRALINA	MOTORINO AVVIAMENTO	REGOLATORE	STATORE
EN	ALTERNATOR	COIL	CDI	STARTER ENGINE	RECTIFIER	STATOR
FR	ALTERNATEUR	BOBINE	BOÎTIER ÉLECTRONIQUE	DÉMARREUR ÉLECTRIQUE	RÉGULATEUR	STATOR
						

HARLEY DAVIDSON	Model	Year	Engine	Part No.	Part No.	Part No.	Part No.	Part No.	Part No.
	FLHTCUTG TRI GLIDE ULTRA	14-14	1690cc 4T						H0505 H0505C
	FLHTCUTG TRI GLIDE ULTRA CLASSIC	09-10	1584cc 4T						H0505 H0505C
	FLHTCUTG TRI GLIDE ULTRA CLASSIC	11-13	1690cc 4T						H0505 H0505C
	FLHTI ELECTRA GLIDE STANDARD	86-87	1340cc 4T				18300BN 18300CN		H1686
	FLHTI ELECTRA GLIDE STANDARD	95-96	1340cc 4T				18199N 18446CN 18446N	18199BN 18199CN	
	FLHTI ELECTRA GLIDE STANDARD	95-98	1450cc 4T						H1988 H1988C
	FLHTI ELECTRA GLIDE STANDARD	97-01	1450cc 4T						H0597 H0597C
	FLHTI ELECTRA GLIDE STANDARD	97-06	1450cc 4T				18199N 18446CN 18446N	18199BN 18199CN	
	FLHTI ELECTRA GLIDE STANDARD	07-07	1584cc 4T				18905BN 18905CN		
	FLHTI ELECTRA GLIDE STANDARD	07-08	1584cc 4T						H0506 H0506C
	FLHTK ELECTRA GLIDE ULTRA LIMITED	10-13	1690cc 4T						H0505 H0505C
	FLHTP POLICE	85-88	1340cc 4T				18300BN 18300CN		
	FLHTP POLICE	89-89	1340cc 4T				17629BN 17629CN		
	FLHTP POLICE	07-07	1584cc 4T						H0506 H0506C
	FLHTP POLICE	12-14	1690cc 4T						H0505 H0505C
	FLHX ELECTRA GLIDE SPECIAL	84-85	1340cc 4T				18300BN 18300CN		H1686
	FLHX STREET GLIDE	06-06	1450cc 4T				18446CN 18446N	18199BN 18199N	H0506
	FLHX STREET GLIDE	06-08	1584cc 4T						H0506C
	FLHX STREET GLIDE	07-07	1584cc 4T				18905BN 18905CN		
	FLHX STREET GLIDE	07-08	1584cc 4T						H0506
	FLHX STREET GLIDE	09-13	1584cc 4T						H0505 H0505C
	FLHX STREET GLIDE	12-13	1690cc 4T						H0505 H0505C
	FLHXI STREET GLIDE	06-06	1450cc 4T				18199BN 18199CN 18199N		H0506 H0506C
	FLHXSE CVO STREET GLIDE	10-10	1800cc 4T				18905BN 18905CN		
	FLHXSE2 CVO STREET GLIDE	11-12	1800cc 4T				18905BN 18905CN		
	FLHXSE3 CVO STREET GLIDE	12-12	1800cc 4T				18905BN 18905CN		
	FLHXXX STREET GLIDE TRIKE	10-11	1690cc 4T						H0505 H0505C
	FLST HERITAGE SOFTAIL	86-90	1340cc 4T				18300BN 18300CN		
	FLST HERITAGE SOFTAIL	06-06	1450cc 4T				18199BN 18199CN 18199N		
	FLSTB SOFTAIL FAT BOY SPECIAL	10-10	1584cc 4T						H4008 H4008C

IT	ALTERNATORE	BOBINA	CENTRALINA	MOTORINO AVVIAMENTO	REGOLATORE	STATORE
EN	ALTERNATOR	COIL	CDI	STARTER ENGINE	RECTIFIER	STATOR
FR	ALTERNATEUR	BOBINE	BOÎTIER ÉLECTRONIQUE	DÉMARREUR ÉLECTRIQUE	RÉGULATEUR	STATOR
						

HARLEY DAVIDSON	Model	Year	Engine	Part 1	Part 2	Part 3	Part 4	Part 5	Part 6
HARLEY DAVIDSON	FLSTC HERITAGE SOFTAIL CLASSIC	88-88	1340cc 4T				18300BN 18300CN		
	FLSTC HERITAGE SOFTAIL CLASSIC	89-90	1340cc 4T				17629BN 17629CN		
	FLSTC HERITAGE SOFTAIL CLASSIC	91-93	1340cc 4T				17629CN-HT 17629N	17629BN 17629CN	
	FLSTC HERITAGE SOFTAIL CLASSIC	94-98	1340cc 4T				18199N 18446CN 18446N	18199BN 18199CN	
	FLSTC HERITAGE SOFTAIL CLASSIC	99-06	1450cc 4T				18199N 18446CN 18446N	18199BN 18199CN	
	FLSTC HERITAGE SOFTAIL CLASSIC	07-07	1584cc 4T				18905BN 18905CN	H4007 H4007C	
	FLSTC HERITAGE SOFTAIL CLASSIC	08-10	1584cc 4T					H4008 H4008C	
	FLSTCI HERITAGE SOFTAIL CLASSIC	88-90	1340cc 4T				17629BN 17629CN		
	FLSTCI HERITAGE SOFTAIL CLASSIC	89-98	1340cc 4T					H1988 H1988C	
	FLSTCI HERITAGE SOFTAIL CLASSIC	91-93	1340cc 4T				17629BN 17629CN 17629N		
	FLSTCI HERITAGE SOFTAIL CLASSIC	92-93	1340cc 4T				17629CN-HT		
	FLSTCI HERITAGE SOFTAIL CLASSIC	94-98	1340cc 4T				18199N 18446CN 18446N	18199BN 18199CN	
	FLSTCI HERITAGE SOFTAIL CLASSIC	99-06	1450cc 4T				18199N 18446CN 18446N	18199BN 18199CN	
	FLSTCI HERITAGE SOFTAIL CLASSIC	00-00	1450cc 4T					H1200 H1200C	
	FLSTCI HERITAGE SOFTAIL CLASSIC	01-06	1450cc 4T					H1001 H1001C	
	FLSTCI HERITAGE SOFTAIL CLASSIC	07-07	1584cc 4T				18905BN 18905CN	H4007 H4007C	
	FLSTCI HERITAGE SOFTAIL CLASSIC	08-09	1584cc 4T					H4008 H4008C	
	FLSTF FAT BOY	90-90	1340cc 4T				17629BN 17629CN		
	FLSTF FAT BOY	91-93	1340cc 4T				17629CN-HT 17629N	17629BN 17629CN	
	FLSTF FAT BOY	94-98	1340cc 4T				18199N 18446CN 18446N	18199BN 18199CN	
FLSTF FAT BOY	99-06	1450cc 4T				18199N 18446CN 18446N	18199BN 18199CN		
FLSTF FAT BOY	07-07	1584cc 4T				18905BN	H4007 H4007C		
FLSTF FAT BOY	07-11	1584cc 4T				18905CN			
FLSTF FAT BOY	08-10	1584cc 4T					H4008 H4008C		
FLSTF FAT BOY	08-11	1584cc 4T				18905BN			
FLSTF FAT BOY	12-13	1690cc 4T				18905BN 18905CN			
FLSTFI FAT BOY	90-90	1340cc 4T				17629BN 17629CN			
FLSTFI FAT BOY	91-93	1340cc 4T				17629CN-HT 17629N	17629BN 17629CN		
FLSTFI FAT BOY	94-98	1340cc 4T				18199N 18446CN 18446N	18199BN 18199CN		
FLSTFI FAT BOY	99-06	1450cc 4T				18446CN 18446N	18199BN 18199N		

IT	ALTERNATORE	BOBINA	CENTRALINA	MOTORINO AVVIAMENTO	REGOLATORE	STATORE
EN	ALTERNATOR	COIL	CDI	STARTER ENGINE	RECTIFIER	STATOR
FR	ALTERNATEUR	BOBINE	BOÎTIER ÉLECTRONIQUE	DÉMARREUR ÉLECTRIQUE	RÉGULATEUR	STATOR
						

HARLEY DAVIDSON	Model	Year	Engine	Part Number	Part Number	Part Number	Part Number	Part Number	Part Number	
HARLEY DAVIDSON	FLSTFI FAT BOY	00-00	1450cc 4T						H1200 H1200C	
	FLSTFI FAT BOY	01-06	1450cc 4T					18199CN		
	FLSTFI FAT BOY	07-07	1584cc 4T						H4007 H4007C	
	FLSTFI FAT BOY	08-09	1584cc 4T						H4008 H4008C	
	FLSTFSE SCREAMIN EAGLE FAT BOY	05-05	1690cc 4T						H1001 H1001C	
	FLSTFSE2 SCREAMIN EAGLE FAT BOY	06-06	1690cc 4T						H1001 H1001C	
	FLSTI HERITAGE SOFTAIL	86-88	1340cc 4T					18300BN 18300CN		
	FLSTI HERITAGE SOFTAIL	89-90	1340cc 4T					17629BN 17629CN	H1988 H1988C	
	FLSTI HERITAGE SOFTAIL	06-06	1450cc 4T					18199N 18446CN 18446N	18199BN 18199CN	H1001 H1001C
	FLSTN HERITAGE SOFTAIL NOSTALGIA	93-93	1340cc 4T					17629CN-HT 17629N	17629BN 17629CN	
	FLSTN HERITAGE SOFTAIL SPECIAL	94-96	1340cc 4T					18199N 18446CN 18446N	18199BN 18199CN	
	FLSTN SOFTAIL DELUXE	05-06	1450cc 4T					18199N 18446CN 18446N	18199BN 18199CN	
	FLSTN SOFTAIL DELUXE	07-07	1584cc 4T						H4007 H4007C	
	FLSTN SOFTAIL DELUXE	07-11	1584cc 4T					18905BN 18905CN		
	FLSTN SOFTAIL DELUXE	08-10	1584cc 4T						H4008 H4008C	
	FLSTN SOFTAIL DELUXE	12-13	1690cc 4T					18905BN 18905CN		
	FLSTNI SOFTAIL DELUXE	93-93	1340cc 4T					17629CN-HT 17629N	17629BN 17629CN	
	FLSTNI SOFTAIL DELUXE	93-96	1340cc 4T					18199N 18446CN 18446N	18199BN 18199CN	H1988 H1988C
	FLSTNI SOFTAIL DELUXE	05-06	1450cc 4T					18199N 18446CN 18446N	18199BN 18199CN	H1001 H1001C
	FLSTNI SOFTAIL DELUXE	07-07	1584cc 4T						H4007 H4007C	
FLSTNI SOFTAIL DELUXE	08-09	1584cc 4T						H4008 H4008C		
FLSTS HERITAGE SPRINGER	97-98	1340cc 4T					18199N 18446CN 18446N	18199BN 18199CN		
FLSTS HERITAGE SPRINGER	99-03	1450cc 4T					18199N 18446CN 18446N	18199BN 18199CN		
FLSTSB CROSS BONES	08-10	1584cc 4T							H4008 H4008C	
FLSTSC SOFTAIL SPRINGER CLASSIC	05-06	1450cc 4T					18446CN 18446N	18199BN 18199N		
FLSTSC SOFTAIL SPRINGER CLASSIC	07-07	1584cc 4T					18905BN 18905CN		H4007 H4007C	
FLSTSCI SOFTAIL SPRINGER CLASSIC	05-06	1450cc 4T					18199N 18446CN 18446N	18199BN 18199CN	H1001 H1001C	
FLSTSCI SOFTAIL SPRINGER CLASSIC	07-07	1584cc 4T							H4007 H4007C	
FLSTSE CVO SOFTAIL CONVERTIBLE	10-10	1584cc 4T					18905BN 18905CN			
FLSTSE2 CVO SOFTAIL CONVERTIBLE	11-12	1800cc 4T					18905BN 18905CN			

IT	ALTERNATORE	BOBINA	CENTRALINA	MOTORINO AVVIAMENTO	REGOLATORE	STATORE
EN	ALTERNATOR	COIL	CDI	STARTER ENGINE	RECTIFIER	STATOR
FR	ALTERNATEUR	BOBINE	BOÎTIER ÉLECTRONIQUE	DÉMARREUR ÉLECTRIQUE	RÉGULATEUR	STATOR
						

HARLEY DAVIDSON	Model	Year	Capacity	Part No.	Part No.	Part No.	Part No.	Part No.	Part No.
HARLEY DAVIDSON	FLSTSE3 CVO SOFTAIL CONVERTIBLE	12-12	1800cc 4T					18905BN 18905CN	
	FLSTSI HERITAGE SPRINGER	97-98	1340cc 4T					18199N 18446CN 18446N	18199BN 18199CN H1988 H1988C
	FLSTSI HERITAGE SPRINGER	99-03	1450cc 4T					18199N 18446CN 18446N	18199BN 18199CN
	FLSTSI HERITAGE SPRINGER	00-00	1450cc 4T						H1200 H1200C
	FLT TOUR GLIDE	80-80	1340cc 4T						H1075 H1075C
	FLT TOUR GLIDE	80-83	1340cc 4T					5780BN 5780CN	
	FLT TOUR GLIDE	83-83	1340cc 4T					18300BN 18300CN 5780CN	
	FLTC TOUR GLIDE CLASSIC	81-81	1340cc 4T					5780BN 5780CN	
	FLTC TOUR GLIDE CLASSIC	82-88	1340cc 4T					18300BN 18300CN	
	FLTC TOUR GLIDE CLASSIC	89-90	1340cc 4T					17629BN 17629CN	
	FLTC TOUR GLIDE CLASSIC	91-91	1340cc 4T					17629CN-HT 17629N	17629BN 17629CN
	FLTC/I TOUR GLIDE CLASSIC	81-81	1340cc 4T					5780BN 5780CN	
	FLTC/I TOUR GLIDE CLASSIC	82-88	1340cc 4T					18300BN 18300CN	
	FLTC/I TOUR GLIDE CLASSIC	89-90	1340cc 4T					17629BN 17629CN	H1988 H1988C
	FLTC/I TOUR GLIDE CLASSIC	91-91	1340cc 4T					17629CN-HT 17629N	17629BN 17629CN H1988 H1988C
	FLTCU TOUR GLIDE ULTRA CLASSIC	89-90	1340cc 4T					17629BN 17629CN	
	FLTCU TOUR GLIDE ULTRA CLASSIC	91-93	1340cc 4T					17629CN-HT 17629N	17629BN 17629CN
	FLTCU TOUR GLIDE ULTRA CLASSIC	94-95	1340cc 4T					18199N 18446CN 18446N	18199BN 18199CN
	FLTCUI TOUR GLIDE ULTRA CLASSIC	89-90	1340cc 4T					17629BN 17629CN	H1988 H1988C
	FLTCUI TOUR GLIDE ULTRA CLASSIC	91-93	1340cc 4T					17629CN-HT 17629N	17629BN 17629CN H1988 H1988C
	FLTCUI TOUR GLIDE ULTRA CLASSIC	94-95	1340cc 4T					18199N 18446CN 18446N	18199BN 18199CN H1988 H1988C
	FLTCUI TOUR GLIDE ULTRA CLASSIC	96-96	1340cc 4T					18199N 18446CN 18446N	18199BN 18199CN H1988 H1988C
	FLTR ROAD GLIDE	99-99	1340cc 4T					18199BN 18199CN 18199N	
	FLTR ROAD GLIDE	99-01	1450cc 4T						H0597 H0597C
	FLTR ROAD GLIDE	00-02	1450cc 4T					18199N 18446CN 18446N	18199BN 18199CN
	FLTR ROAD GLIDE	02-02	1450cc 4T						H0502 H0502C
	FLTR ROAD GLIDE	07-07	1584cc 4T					18905BN 18905CN	
	FLTR ROAD GLIDE	07-08	1584cc 4T						H0506 H0506C
FLTR ROAD GLIDE	09-09	1584cc 4T						H0505 H0505C	
FLTR ROAD GLIDE	98-99	1638cc 4T					18199N 18446CN 18446N	18199BN 18199CN	

IT	ALTERNATORE	BOBINA	CENTRALINA	MOTORINO AVVIAMENTO	REGOLATORE	STATORE
EN	ALTERNATOR	COIL	CDI	STARTER ENGINE	RECTIFIER	STATOR
FR	ALTERNATEUR	BOBINE	BOÎTIER ÉLECTRONIQUE	DÉMARREUR ÉLECTRIQUE	RÉGULATEUR	STATOR
						

HARLEY DAVIDSON	Model	Year	Engine	Part 1	Part 2	Part 3	Part 4	Part 5	Part 6
HARLEY DAVIDSON	FLTRI ROAD GLIDE	98-98	1340cc 4T				18199N 18446CN 18446N	18199BN 18199CN	H1988 H1988C
	FLTRI ROAD GLIDE	99-01	1450cc 4T						H0597 H0597C
	FLTRI ROAD GLIDE	99-06	1450cc 4T				18199N 18446CN 18446N	18199BN 18199CN	
	FLTRI ROAD GLIDE	02-03	1450cc 4T						H0502 H0502C
	FLTRI ROAD GLIDE	06-06	1450cc 4T						H0506
	FLTRI ROAD GLIDE	06-08	1584cc 4T						H0506C
	FLTRI ROAD GLIDE	07-08	1584cc 4T						H0506
	FLTRSE3 CVO ROAD GLIDE	09-09	1584cc 4T					18905BN 18905CN	
	FLTRSE1 SCREAMIN EAGLE ROAD GLIDE	00-00	1550cc 4T				18199N 18446CN 18446N	18199BN 18199CN	
	FLTRSE12 SCREAMIN EAGLE ROAD GLIDE 2	01-01	1550cc 4T				18199N 18446CN 18446N	18199BN 18199CN	
	FLTRU ROAD GLIDE ULTRA	11-13	1690cc 4T						H0505 H0505C
	FLTRUSE CVO ROAD GLIDE ULTRA	11-11	1800cc 4T					18905BN 18905CN	
	FLTRX ROAD GLIDE CUSTOM	10-13	1584cc 4T						H0505 H0505C
	FLTRX ROAD GLIDE CUSTOM	12-13	1690cc 4T						H0505 H0505C
	FX SUPER GLIDE	71-75	1200cc 4T						H1070 H1070C
	FX SUPER GLIDE	71-78	1200cc 4T					18300BN 18300CN	
	FXB STURGIS	80-82	1340cc 4T					18300BN 18300CN	
	FXCW ROCKER	08-09	1584cc 4T						H4008 H4008C
	FXCWC ROCKER C	08-10	1584cc 4T						H4008 H4008C
	FXD DYNA SUPER GLIDE	95-98	1340cc 4T				18199N 18446CN 18446N	18199BN 18199CN	
FXD DYNA SUPER GLIDE	99-05	1450cc 4T				18199N 18446CN 18446N	18199BN 18199CN		
FXD DYNA SUPER GLIDE	05-05	1450cc 4T						H3104 H3104C	
FXD DYNA SUPER GLIDE	07-07	1584cc 4T					18905BN 18905CN	H3106 H3106C	
FXD DYNA SUPER GLIDE	08-10	1584cc 4T						H3108 H3108C	
FXD35 SUPER GOLDEN ANNIVERSARY	06-06	1450cc 4T				18446CN 18446N	18199BN 18199N		
FXD35 SUPER GOLDEN ANNIVERSARY	06-06	1450cc 4T						H3106 H3106C	
FXDB STREET BOB	07-07	1584cc 4T						H3106 H3106C	
FXDB STREET BOB	08-13	1584cc 4T						H3108C	
FXDB STREET BOB	09-14	1690cc 4T						H3108	
FXDB STREET BOB	14-14	1690cc 4T						H3108 H3108C	

IT	ALTERNATORE	BOBINA	CENTRALINA	MOTORINO AVVIAMENTO	REGOLATORE	STATORE
EN	ALTERNATOR	COIL	CDI	STARTER ENGINE	RECTIFIER	STATOR
FR	ALTERNATEUR	BOBINE	BOÎTIER ÉLECTRONIQUE	DÉMARREUR ÉLECTRIQUE	RÉGULATEUR	STATOR
						

HARLEY DAVIDSON	Model	Year	Capacity	Part 1	Part 2	Part 3	Part 4	Part 5	Part 6
HARLEY DAVIDSON	FXDB-D DYNA GLIDE DAYTONA	92-92	1340cc 4T				17629CN-HT 17629N	17629BN 17629CN	
	FXDB-S DYNA GLIDE STURGIS	91-91	1340cc 4T				17629CN-HT 17629N	17629BN 17629CN	
	FXDBA STREET BOB	06-06	1584cc 4T						H3106 H3106C
	FXDBA STREET BOB	13-13	1584cc 4T						H3108 H3108C
	FXDBI STREET BOB	06-06	1450cc 4T				18199N 18446CN 18446N	18199BN 18199CN	H3106 H3106C
	FXDBP STREET BOB	13-14	1584cc 4T						H3108 H3108C
	FXDC SUPER GLIDE CUSTOM	92-92	1340cc 4T				17629CN-HT 17629N	17629BN 17629CN	
	FXDC SUPER GLIDE CUSTOM	05-05	1450cc 4T				18199N 18446CN 18446N	18199BN 18199CN	H3104 H3104C
	FXDC SUPER GLIDE CUSTOM	07-07	1584cc 4T						H3106 H3106C
	FXDC SUPER GLIDE CUSTOM	08-13	1584cc 4T						H3108 H3108C
	FXDC SUPER GLIDE CUSTOM	14-14	1690cc 4T						H3108 H3108C
	FXDCI SUPER GLIDE CUSTOM	05-05	1450cc 4T						H3104 H3104C
	FXDCI SUPER GLIDE CUSTOM	06-06	1450cc 4T				18199N 18446CN 18446N	18199BN 18199CN	H3106 H3106C
	FXDF FAT BOB	08-13	1584cc 4T						H3108 H3108C
	FXDF FAT BOB	12-14	1690cc 4T						H3108 H3108C
	FXDF FAT BOB	10-10	1800cc 4T						H3108 H3108C
	FXDFSE CVO DYNA FAT BOB	09-09	1800cc 4T					18905BN 18905CN	H3108 H3108C
	FXDFSE2 CVO DYNA FAT BOB	10-10	1584cc 4T					18905BN 18905CN	
	FXDG DISC GLIDE	83-83	1340cc 4T					18300BN 18300CN	H1686
	FXDI DYNA SUPER GLIDE	95-98	1340cc 4T				18199N 18446CN 18446N	18199BN 18199CN	H1988 H1988C
FXDI DYNA SUPER GLIDE	99-03	1450cc 4T						H1899 H1899C	
FXDI DYNA SUPER GLIDE	99-06	1450cc 4T				18199N 18446CN 18446N	18199BN 18199CN		
FXDI DYNA SUPER GLIDE	04-05	1450cc 4T						H3104 H3104C	
FXDI DYNA SUPER GLIDE	06-07	1450cc 4T						H3106 H3106C	
FXDI DYNA SUPER GLIDE	08-09	1584cc 4T						H3108 H3108C	
FXDI35 DYNA 35TH ANNIVERSARY SUPER GLIDE	06-06	1450cc 4T						H3106 H3106C	
FXDL DYNA LOW RIDER	93-93	1340cc 4T				17629CN-HT 17629N	17629BN 17629CN		
FXDL DYNA LOW RIDER	94-98	1340cc 4T				18199N 18446CN 18446N	18199BN 18199CN		
FXDL DYNA LOW RIDER	99-05	1450cc 4T				18199N 18446CN 18446N	18199BN 18199CN		
FXDL DYNA LOW RIDER	05-05	1450cc 4T						H3104 H3104C	

IT	ALTERNATORE	BOBINA	CENTRALINA	MOTORINO AVVIAMENTO	REGOLATORE	STATORE
EN	ALTERNATOR	COIL	CDI	STARTER ENGINE	RECTIFIER	STATOR
FR	ALTERNATEUR	BOBINE	BOÎTIER ÉLECTRONIQUE	DÉMARREUR ÉLECTRIQUE	RÉGULATEUR	STATOR
						

HARLEY DAVIDSON	Model	Year	Engine	Part No.	Part No.	Part No.	Part No.	Part No.	Part No.
HARLEY DAVIDSON	FXDL DYNA LOW RIDER	06-07	1584cc 4T						H3106 H3106C
	FXDL DYNA LOW RIDER	07-07	1584cc 4T					18905BN 18905CN	
	FXDL DYNA LOW RIDER	08-11	1584cc 4T						H3108 H3108C
	FXDLI DYNA LOW RIDER	93-93	1340cc 4T				17629CN-HT 17629N	17629BN 17629CN	H1988 H1988C
	FXDLI DYNA LOW RIDER	94-98	1340cc 4T				18199N 18446CN 18446N	18199BN 18199CN	H1988 H1988C
	FXDLI DYNA LOW RIDER	99-03	1450cc 4T						H1899 H1899C
	FXDLI DYNA LOW RIDER	99-06	1450cc 4T				18199N 18446CN 18446N	18199BN 18199CN	
	FXDLI DYNA LOW RIDER	04-05	1450cc 4T						H3104 H3104C
	FXDLI DYNA LOW RIDER	06-07	1584cc 4T						H3106 H3106C
	FXDLI DYNA LOW RIDER	08-09	1584cc 4T						H3108 H3108C
	FXDSE-CONV DYNA CONVERTIBLE	94-98	1340cc 4T				18199N 18446CN 18446N	18199BN 18199CN	
	FXDSE-CONV DYNA CONVERTIBLE	99-00	1450cc 4T				18199N 18446CN 18446N	18199BN 18199CN	H1899 H1899C
	FXDSE SCREAMIN EAGLE DYNA	07-07	1800cc 4T					18905BN 18905CN	H3106 H3106C
	FXDSE2 SCREAMIN EAGLE DYNA	08-08	1800cc 4T					18905BN 18905CN	H3108 H3108C
	FXDWG DYNA WIDE GLIDE	93-93	1340cc 4T				17629CN-HT 17629N	17629BN 17629CN	
	FXDWG DYNA WIDE GLIDE	94-98	1340cc 4T				18199N 18446CN 18446N	18199BN 18199CN	
	FXDWG DYNA WIDE GLIDE	99-05	1450cc 4T				18199N 18446CN 18446N	18199BN 18199CN	
	FXDWG DYNA WIDE GLIDE	05-05	1450cc 4T						H3104 H3104C
	FXDWG DYNA WIDE GLIDE	07-07	1584cc 4T					18905BN 18905CN	H3106 H3106C
	FXDWG DYNA WIDE GLIDE	08-11	1584cc 4T						H3108 H3108C
	FXDWG DYNA WIDE GLIDE	12-14	1690cc 4T						H3108 H3108C
	FXDWG2	01-01	1450cc 4T				18199N 18446CN 18446N	18199BN 18199CN	
	FXDWG3	02-02	1450cc 4T				18199N 18446CN 18446N	18199BN 18199CN	
	FXDWGI DYNA WIDE GLIDE	93-93	1340cc 4T				17629CN-HT 17629N	17629BN 17629CN	H1988 H1988C
	FXDWGI DYNA WIDE GLIDE	94-98	1340cc 4T				18199N 18446CN 18446N	18199BN 18199CN	H1988 H1988C
	FXDWGI DYNA WIDE GLIDE	99-03	1450cc 4T					18199CN	H1899 H1899C
	FXDWGI DYNA WIDE GLIDE	99-06	1450cc 4T				18446CN 18446N	18199BN 18199N	
	FXDWGI DYNA WIDE GLIDE	04-05	1450cc 4T						H3104 H3104C
FXDWGI DYNA WIDE GLIDE	06-07	1584cc 4T						H3106 H3106C	
FXDWGI DYNA WIDE GLIDE	08-08	1584cc 4T						H3108 H3108C	

IT	ALTERNATORE	BOBINA	CENTRALINA	MOTORINO AVVIAMENTO	REGOLATORE	STATORE
EN	ALTERNATOR	COIL	CDI	STARTER ENGINE	RECTIFIER	STATOR
FR	ALTERNATEUR	BOBINE	BOÎTIER ÉLECTRONIQUE	DÉMARREUR ÉLECTRIQUE	RÉGULATEUR	STATOR
						

HARLEY DAVIDSON	Model	Year	Capacity	Part 1	Part 2	Part 3	Part 4	Part 5	Part 6
HARLEY DAVIDSON	FXDX DYNA SUPER GLIDE SPORT	99-03	1450cc 4T						H1899 H1899C
	FXDX DYNA SUPER GLIDE SPORT	99-05	1450cc 4T				18199N 18446CN 18446N	18199BN 18199CN	
	FXDX DYNA SUPER GLIDE SPORT	04-05	1450cc 4T						H3104 H3104C
	FXDXI DYNA SUPER GLIDE SPORT	04-05	1450cc 4T				18199N 18446CN 18446N	18199BN 18199CN	H3104 H3104C
	FXDXT DYNA SUPER GLIDE T-SPORT	01-03	1450cc 4T				18199N 18446CN 18446N	18199BN 18199CN	H1899 H1899C
	FXE SUPER GLIDE	74-75	1200cc 4T						H1070 H1070C
	FXE SUPER GLIDE	74-80	1200cc 4T					18300BN 18300CN	
	FXE SUPER GLIDE	79-84	1340cc 4T					18300BN 18300CN	
	FXEF FAT BOB	79-81	1340cc 4T					18300BN	
	FXEF FAT BOB	79-85	1340cc 4T					18300CN	
	FXEF FAT BOB	85-85	1340cc 4T					18300BN	
	FXLR LOW RIDER CUSTOM	87-88	1340cc 4T					18300BN 18300CN	
	FXLR LOW RIDER CUSTOM	89-90	1340cc 4T					17629BN 17629CN	H1988 H1988C
	FXLR LOW RIDER CUSTOM	91-93	1340cc 4T				17629CN-HT 17629N	17629BN 17629CN	H1988 H1988C
	FXLR LOW RIDER CUSTOM	94-94	1340cc 4T				18199N 18446CN 18446N	18199BN 18199CN	H1988 H1988C
	FXR SUPER GLIDE II	82-83	1340cc 4T					5780BN 5780CN	H1686
	FXR SUPER GLIDE II	83-88	1340cc 4T					18300BN 18300CN	H1686
	FXR SUPER GLIDE II	89-90	1340cc 4T					17629BN 17629CN	H1988 H1988C
	FXR SUPER GLIDE II	91-93	1340cc 4T				17629CN-HT 17629N	17629BN 17629CN	H1988 H1988C
	FXR SUPER GLIDE II	94-94	1340cc 4T				18199N 18446CN 18446N	18199BN 18199CN	H1988 H1988C
FXR2	99-99	1340cc 4T				18199N 18446CN 18446N	18199BN 18199CN	H1988 H1988C	
FXR3	99-99	1340cc 4T				18199N 18446CN 18446N	18199BN 18199CN	H1988 H1988C	
FXR4	00-00	1450cc 4T				18199N 18446CN 18446N	18199BN 18199CN		
FXRC LOW RIDER CHROME	85-87	1340cc 4T					18300BN 18300CN	H1686	
FXRD SPORT GLIDE GRAND TOURING	86-86	1340cc 4T					18300BN 18300CN	H1686	
FXRDG DISC GLIDE	84-84	1340cc 4T					18300BN 18300CN	H1686	
FXRP POLICE	85-88	1340cc 4T					18300BN 18300CN		
FXRP POLICE	89-89	1340cc 4T					17629BN 17629CN		
FXRS LOW GLIDE	82-83	1340cc 4T					5780BN 5780CN	H1686	
FXRS LOW GLIDE	84-88	1340cc 4T					18300BN 18300CN	H1686	

IT	ALTERNATORE	BOBINA	CENTRALINA	MOTORINO AVVIAMENTO	REGOLATORE	STATORE
EN	ALTERNATOR	COIL	CDI	STARTER ENGINE	RECTIFIER	STATOR
FR	ALTERNATEUR	BOBINE	BOÎTIER ÉLECTRONIQUE	DÉMARREUR ÉLECTRIQUE	RÉGULATEUR	STATOR
						

HARLEY DAVIDSON	Model	Year	Engine	Part 1	Part 2	Part 3	Part 4	Part 5	Part 6	
HARLEY DAVIDSON	FXRS LOW GLIDE	89-90	1340cc 4T					17629BN 17629CN	H1988 H1988C	
	FXRS LOW GLIDE	91-92	1340cc 4T					17629CN-HT 17629N	17629BN 17629CN	H1988 H1988C
	FXRS LOW RIDER LIBERTY	86-86	1340cc 4T					18300BN 18300CN		
	FXRS-CONV LOW RIDER SPORT CONVERTIBLE	90-90	1340cc 4T					17629BN 17629CN		H1988 H1988C
	FXRS-CONV LOW RIDER SPORT CONVERTIBLE	91-93	1340cc 4T					17629CN-HT 17629N	17629BN 17629CN	H1988 H1988C
	FXRS-SP LOW RIDER SPORT	86-88	1340cc 4T							H1686
	FXRS-SP LOW RIDER SPORT	86-90	1340cc 4T					17629BN 17629CN		
	FXRS-SP LOW RIDER SPORT	89-93	1340cc 4T							H1988 H1988C
	FXRS-SP LOW RIDER SPORT	91-93	1340cc 4T					17629CN-HT 17629N	17629BN 17629CN	
	FXRT SPORT GLIDE	83-88	1340cc 4T					18300BN 18300CN		H1686
	FXRT SPORT GLIDE	89-90	1340cc 4T					17629BN 17629CN		H1988 H1988C
	FXRT SPORT GLIDE	91-92	1340cc 4T					17629CN-HT 17629N	17629BN 17629CN	H1988 H1988C
	FXS LOW RIDER	77-78	1200cc 4T					18300CN		
	FXS LOW RIDER	77-82	1340cc 4T					18300BN		
	FXS LOW RIDER	79-82	1340cc 4T					18300CN		
	FXSB LOW RIDER - BELT	83-85	1340cc 4T					18300BN 18300CN		
	FXSBSE CVO BREAKOUT	13-13	1800cc 4T					18905BN		
	FXST SOFTAIL STANDARD	84-88	1340cc 4T					18300BN 18300CN		
	FXST SOFTAIL STANDARD	89-90	1340cc 4T					17629BN 17629CN		
	FXST SOFTAIL STANDARD	99-99	1340cc 4T					18199N 18446CN 18446N	18199BN 18199CN	
	FXST SOFTAIL STANDARD	00-06	1450cc 4T					18199N 18446CN 18446N	18199BN 18199CN	
	FXST SOFTAIL STANDARD	07-07	1584cc 4T					18905BN 18905CN		H4007 H4007C
	FXST SOFTAIL STANDARD	08-08	1584cc 4T							H4008 H4008C
	FXSTB NIGHT TRAIN	99-99	1340cc 4T					18199N 18446CN 18446N	18199BN 18199CN	
	FXSTB NIGHT TRAIN	00-06	1450cc 4T					18199N 18446CN 18446N	18199BN 18199CN	
	FXSTB NIGHT TRAIN	07-07	1584cc 4T					18905BN 18905CN		H4007 H4007C
	FXSTBI NIGHT TRAIN	99-99	1340cc 4T					18199N 18446CN 18446N	18199BN 18199CN	H1988 H1988C
	FXSTBI NIGHT TRAIN	00-00	1450cc 4T							H1200 H1200C
FXSTBI NIGHT TRAIN	00-06	1450cc 4T					18199N 18446CN 18446N	18199BN 18199CN		
FXSTBI NIGHT TRAIN	07-07	1584cc 4T							H4007 H4007C	

IT	ALTERNATORE	BOBINA	CENTRALINA	MOTORINO AVVIAMENTO	REGOLATORE	STATORE
EN	ALTERNATOR	COIL	CDI	STARTER ENGINE	RECTIFIER	STATOR
FR	ALTERNATEUR	BOBINE	BOÎTIER ÉLECTRONIQUE	DÉMARREUR ÉLECTRIQUE	RÉGULATEUR	STATOR
						

HARLEY DAVIDSON	Model	Year	CC	Part 1	Part 2	Part 3	Part 4	Part 5	Part 6	
HARLEY DAVIDSON	FXSTBI NIGHT TRAIN	08-09	1584cc 4T						H4008 H4008C	
	FXSTC SOFTAIL CUSTOM	86-88	1340cc 4T					18300BN 18300CN		
	FXSTC SOFTAIL CUSTOM	89-90	1340cc 4T					17629BN 17629CN	H1988 H1988C	
	FXSTC SOFTAIL CUSTOM	91-93	1340cc 4T					17629CN-HT 17629N 17629CN	H1988 H1988C	
	FXSTC SOFTAIL CUSTOM	94-99	1340cc 4T					18199N 18446CN 18446N	18199BN 18199CN	H1988 H1988C
	FXSTC SOFTAIL CUSTOM	07-07	1584cc 4T					18905BN 18905CN	H4007 H4007C	
	FXSTC SOFTAIL CUSTOM	08-10	1584cc 4T						H4008 H4008C	
	FXSTD SOFTAIL DEUCE	00-06	1450cc 4T					18199N 18446CN 18446N	18199BN 18199CN	
	FXSTD SOFTAIL DEUCE	07-07	1584cc 4T					18905BN 18905CN	H4007 H4007C	
	FXSTDI SOFTAIL DEUCE	00-00	1450cc 4T						H1200 H1200C	
	FXSTDI SOFTAIL DEUCE	00-06	1450cc 4T					18199N 18446CN 18446N	18199BN 18199CN	
	FXSTDI SOFTAIL DEUCE	01-06	1450cc 4T						H1001 H1001C	
	FXSTDI SOFTAIL DEUCE	07-07	1584cc 4T						H4007 H4007C	
	FXSTDSE SCREAMIN EAGLE SOFTAIL DEUCE	03-03	1550cc 4T					18199N 18446CN 18446N	18199BN 18199CN	
	FXSTDSE2 SCREAMIN EAGLE SOFTAIL DEUCE 2	04-04	1550cc 4T					18199N 18446CN 18446N	18199BN 18199CN	
	FXSTI SOFTAIL STANDARD	84-88	1340cc 4T					18300BN 18300CN		
	FXSTI SOFTAIL STANDARD	89-90	1340cc 4T					17629BN 17629CN		
	FXSTI SOFTAIL STANDARD	89-91	1340cc 4T						H1988 H1988C	
	FXSTI SOFTAIL STANDARD	99-99	1340cc 4T					18199BN 18199CN 18199N		
	FXSTI SOFTAIL STANDARD	00-00	1450cc 4T						H1200 H1200C	
	FXSTI SOFTAIL STANDARD	00-06	1450cc 4T					18199N 18446CN 18446N	18199BN 18199CN	
	FXSTI SOFTAIL STANDARD	01-06	1450cc 4T						H1001 H1001C	
	FXSTI SOFTAIL STANDARD	07-07	1584cc 4T						H4007 H4007C	
	FXSTS SPRINGER SOFTAIL	88-88	1340cc 4T					18300BN 18300CN		
	FXSTS SPRINGER SOFTAIL	89-90	1340cc 4T					17629BN 17629CN		
	FXSTS SPRINGER SOFTAIL	91-93	1340cc 4T					17629CN-HT 17629N 17629CN	17629BN 17629CN	
	FXSTS SPRINGER SOFTAIL	94-99	1340cc 4T					18199N 18446CN 18446N	18199BN 18199CN	
	FXSTS SPRINGER SOFTAIL	00-06	1450cc 4T					18199N 18446CN 18446N	18199BN 18199CN	
FXSTSB BAD BOY	95-97	1340cc 4T					18199N 18446CN 18446N	18199BN 18199CN	H1988 H1988C	
FXSTSI SPRINGER SOFTAIL	88-88	1340cc 4T					18300BN 18300CN			

IT	ALTERNATORE	BOBINA	CENTRALINA	MOTORINO AVVIAMENTO	REGOLATORE	STATORE
EN	ALTERNATOR	COIL	CDI	STARTER ENGINE	RECTIFIER	STATOR
FR	ALTERNATEUR	BOBINE	BOÎTIER ÉLECTRONIQUE	DÉMARREUR ÉLECTRIQUE	RÉGULATEUR	STATOR
						

HARLEY DAVIDSON	Model	Year	Engine	Part 1	Part 2	Part 3	Part 4	Part 5	Part 6
	FXSTS1 SPRINGER SOFTAIL	89-90	1340cc 4T				17629BN 17629CN	H1988 H1988C	
	FXSTS1 SPRINGER SOFTAIL	91-93	1340cc 4T				17629CN-HT 17629N	17629BN 17629CN	H1988 H1988C
	FXSTS1 SPRINGER SOFTAIL	94-99	1340cc 4T				18199N 18446CN 18446N	18199BN 18199CN	H1988 H1988C
	FXSTS1 SPRINGER SOFTAIL	00-00	1450cc 4T						H1200 H1200C
	FXSTS1 SPRINGER SOFTAIL	00-06	1450cc 4T				18199N 18446CN 18446N	18199BN 18199CN	
	FXSTS1 SPRINGER SOFTAIL	01-06	1450cc 4T						H1001 H1001C
	FXSTSSE SCREAMIN EAGLE SOFTAIL SPRINGER	07-07	1800cc 4T				18905BN 18905CN		H4007 H4007C
	FXSTSSE2 SCREAMIN EAGLE SOFTAIL SPRINGER	08-08	1800cc 4T				18905BN 18905CN		H4008 H4008C
	FXSTSSE3 CVO SOFTAIL SPRINGER	09-09	1584cc 4T				18905BN 18905CN		H4008 H4008C
	FXWG WIDE GLIDE	80-86	1340cc 4T				18300BN 18300CN		
	VRSCA V-ROD	02-06	1130cc 4T				18478N 18478NC		
	VRSCAW V-ROD	07-07	1130cc 4T				18478N 18478NC		
	VRSCAW V-ROD	08-10	1250cc 4T				18478N 18478NC	H4408 H4408C	
	VRSCB V-ROD	04-05	1130cc 4T				18478N 18478NC		
	VRSCD NIGHT ROD	06-07	1130cc 4T				18478N 18478NC		
	VRSCD NIGHT ROD	08-08	1250cc 4T				18478N 18478NC	H4408 H4408C	
	VRSCDX ANN V-ROD ANNIVERSARY EDITION	12-12	1250cc 4T				18478N 18478NC	H4408 H4408C	
	VRSCDX NIGHT ROD SPECIAL	07-07	1130cc 4T				18478N 18478NC		
	VRSCDX NIGHT ROD SPECIAL	08-13	1250cc 4T				18478N 18478NC	H4408 H4408C	
	VRSCDX NIGHT ROD SPECIAL	14-14	1250cc 4T				18478N 18478NC	H4408 H4408C	
	VRSCF V-ROD MUSCLE	09-13	1250cc 4T				18478N 18478NC	H4408 H4408C	
	VRSCF V-ROD MUSCLE	14-14	1250cc 4T				18478N 18478NC	H4408 H4408C	
	VRSCR STREET ROD	06-07	1130cc 4T				18478N 18478NC		
	VRSCSE SCREAMIN EAGLE V-ROD	05-05	1250cc 4T				18478N 18478NC		
	VRSCSE2 SCREAMIN EAGLE V-ROD 2	06-06	1250cc 4T				18478N 18478NC		
	VRSCX V-ROD	07-07	1250cc 4T				18478N 18478NC		
	VRXSE SCREAMIN EAGLE DESTROYER	06-06	1300cc 4T				18478N 18478NC		
	XL SPORTSTER	93-03	883cc 4T				18477NC		
	XL SPORTSTER	93-95	1200cc 4T				18477NC		
	XL SPORTSTER ANNIV.	93-93	1200cc 4T				18477NC		

IT	ALTERNATORE	BOBINA	CENTRALINA	MOTORINO AVVIAMENTO	REGOLATORE	STATORE
EN	ALTERNATOR	COIL	CDI	STARTER ENGINE	RECTIFIER	STATOR
FR	ALTERNATEUR	BOBINE	BOÎTIER ÉLECTRONIQUE	DÉMARREUR ÉLECTRIQUE	RÉGULATEUR	STATOR
						

HARLEY DAVIDSON	Model	Year	Engine	Part 1	Part 2	Part 3	Part 4	Part 5	Part 6
	XL SPORTSTER DELUXE	93-95	883cc 4T				18477NC		
	XL SPORTSTER HUGGER	93-03	883cc 4T				18477NC		
	XL1200C SPORTSTER 1200 CUSTOM	96-03	1200cc 4T					H2394 H2394C	
	XL1200C SPORTSTER 1200 CUSTOM	96-14	1200cc 4T				18477N		
	XL1200C SPORTSTER 1200 CUSTOM	04-06	1200cc 4T					H2304 H2304C	
	XL1200C SPORTSTER 1200 CUSTOM	07-08	1200cc 4T					H4607 H4607C	
	XL1200C SPORTSTER 1200 CUSTOM	09-13	1200cc 4T					H1108 H1108C	
	XL1200C SPORTSTER 1200 CUSTOM	14-14	1200cc 4T				18477NC		
	XL1200CA 1200 CUSTOM LIMITED A	13-13	1200cc 4T					H1108 H1108C	
	XL1200CB 1200 CUSTOM LIMITED B	13-13	1200cc 4T					H1108 H1108C	
	XL1200CP 1200 CUSTOM	11-13	1200cc 4T					H1108 H1108C	
	XL1200L SPORTSTER 1200 LOW	06-06	1200cc 4T					H2304 H2304C	
	XL1200L SPORTSTER 1200 LOW	06-11	1200cc 4T				18477NC		
	XL1200L SPORTSTER 1200 LOW	07-08	1200cc 4T					H4607 H4607C	
	XL1200L SPORTSTER 1200 LOW	09-10	1200cc 4T					H1108 H1108C	
	XL1200N SPORTSTER 1200 NIGHTSTER	07-08	1200cc 4T					H4607 H4607C	
	XL1200N SPORTSTER 1200 NIGHTSTER	07-12	1200cc 4T				18477NC		
	XL1200N SPORTSTER 1200 NIGHTSTER	09-12	1200cc 4T					H1108 H1108C	
	XL1200R SPORTSTER 1200 ROADSTER	04-06	1200cc 4T					H2304 H2304C	
	XL1200R SPORTSTER 1200 ROADSTER	04-08	1200cc 4T				18477NC		
	XL1200R SPORTSTER 1200 ROADSTER	07-08	1200cc 4T					H4607 H4607C	
	XL1200R SPORTSTER 1200 ROADSTER	09-09	1200cc 4T					H1108 H1108C	
	XL1200S SPORTSTER 1200 SPORT	96-03	1200cc 4T				18477NC	H2394 H2394C	
	XL1200V SEVENTY-TWO	12-13	1200cc 4T					H1108 H1108C	
	XL1200V SEVENTY-TWO	12-14	1200cc 4T				18477N		
	XL1200V SEVENTY-TWO	14-14	1200cc 4T				18477NC		
	XL1200X FORTY-EIGHT	10-14	1200cc 4T				18477N		
	XL1200X FORTY-EIGHT	11-13	1200cc 4T					H1108 H1108C	
	XL1200X FORTY-EIGHT	14-14	1200cc 4T				18477NC		
	XL50 50TH ANNIVERSARY SPORTSTER	07-07	1200cc 4T				18477NC	H4607 H4607C	

IT	ALTERNATORE	BOBINA	CENTRALINA	MOTORINO AVVIAMENTO	REGOLATORE	STATORE
EN	ALTERNATOR	COIL	CDI	STARTER ENGINE	RECTIFIER	STATOR
FR	ALTERNATEUR	BOBINE	BOÎTIER ÉLECTRONIQUE	DÉMARREUR ÉLECTRIQUE	RÉGULATEUR	STATOR
						

HARLEY DAVIDSON	Model	Year	Engine	Part	Part	Part	Part	Part	Part
	XL883 SPORTSTER	04-06	883cc 4T						H2304 H2304C
	XL883 SPORTSTER	04-08	883cc 4T				18477NC		
	XL883 SPORTSTER	07-08	883cc 4T						H4607 H4607C
	XL883 SPORTSTER	09-09	883cc 4T						H1108 H1108C
	XL883C SPORTSTER 883 CUSTOM	98-98	883cc 4T				18477NC		
	XL883C SPORTSTER 883 CUSTOM	98-03	883cc 4T						H2394 H2394C
	XL883C SPORTSTER 883 CUSTOM	98-10	883cc 4T				18477NC		
	XL883C SPORTSTER 883 CUSTOM	04-06	883cc 4T						H2304 H2304C
	XL883C SPORTSTER 883 CUSTOM	07-08	883cc 4T						H4607 H4607C
	XL883C SPORTSTER 883 CUSTOM	09-10	883cc 4T						H1108 H1108C
	XL883L SPORTSTER 883 LOW	05-06	883cc 4T						H2304 H2304C
	XL883L SPORTSTER 883 LOW	05-11	883cc 4T				18477NC		
	XL883L SPORTSTER 883 LOW	07-08	883cc 4T						H4607 H4607C
	XL883L SPORTSTER 883 LOW	09-10	883cc 4T						H1108 H1108C
	XL883L SUPERLOW	11-13	883cc 4T						H1108 H1108C
	XL883L SUPERLOW	11-14	883cc 4T				18477N 18477NC		
	XL883N IRON 883	09-13	883cc 4T						H1108 H1108C
	XL883N IRON 883	09-14	883cc 4T				18477N		
	XL883N IRON 883	14-14	883cc 4T				18477NC		
	XL883R SPORTSTER 883 ROADSTER	02-03	883cc 4T						H2394 H2394C
	XL883R SPORTSTER 883 ROADSTER	02-13	883cc 4T				18477NC		
	XL883R SPORTSTER 883 ROADSTER	05-06	883cc 4T						H2304 H2304C
	XL883R SPORTSTER 883 ROADSTER	07-08	883cc 4T						H4607 H4607C
	XL883R SPORTSTER 883 ROADSTER	08-09	883cc 4T				18477NC		
	XL883R SPORTSTER 883 ROADSTER	09-13	883cc 4T						H1108 H1108C
	XLC	58-58	900cc 4T				15410BN		
	XLC	58-58	900cc 4T				5780BN 5780CN		
	XLC SPORTSTER CUSTOM	00-07	883cc 4T				18477NC		
	XLC SPORTSTER CUSTOM	00-07	1200cc 4T				18477NC		
	XLCH	58-71	900cc 4T				15410BN		

IT	ALTERNATORE	BOBINA	CENTRALINA	MOTORINO AVVIAMENTO	REGOLATORE	STATORE
EN	ALTERNATOR	COIL	CDI	STARTER ENGINE	RECTIFIER	STATOR
FR	ALTERNATEUR	BOBINE	BOÎTIER ÉLECTRONIQUE	DÉMARREUR ÉLECTRIQUE	RÉGULATEUR	STATOR
						

HARLEY DAVIDSON									
	Model	Year	Capacity	Part 1	Part 2	Part 3	Part 4	Part 5	Part 6
XLCH	58-71	900cc 4T				5780BN 5780CN			
	72-75	1200cc 4T					H1070 H1070C		
XLCH	72-78	1200cc 4T				15410BN			
XLCH	72-78	1200cc 4T				5780BN 5780CN			
XLCH	74-76	1200cc 4T				18300BN 18300CN			
XLCH	79-79	1340cc 4T				15410BN			
XLCH	79-79	1340cc 4T				5780BN 5780CN			
XLCH SPORTSTER	75-78	1000cc 4T				5780BN 5780CN			
XLCR CAFE RACER	77-78	1000cc 4T				15410BN			
XLCR CAFE RACER	77-78	1000cc 4T				5780BN 5780CN			
XLH SPORTSTER	86-90	883cc 4T				18477N 18477NC			
XLH SPORTSTER	91-92	883cc 4T				18477NC			
XLH SPORTSTER	75-85	1000cc 4T				5780BN 5780CN			
XLH SPORTSTER	79-84	1000cc 4T				15410BN			
XLH SPORTSTER	81-85	1000cc 4T				18477N 18477NC			
XLH SPORTSTER	82-84	1000cc 4T				15410BN			
XLH SPORTSTER	86-87	1100cc 4T				18477N 18477NC			
XLH SPORTSTER	87-90	1200cc 4T				18477N 18477NC			
XLH SPORTSTER	91-92	1200cc 4T				18477NC			
XLH SPORTSTER ANNIV.	78-78	1000cc 4T				5780BN 5780CN			
XLH SPORTSTER LIBERTY	86-86	1100cc 4T				18477N 18477NC			
XLH TOURING	77-77	1000cc 4T				5780BN 5780CN			
XLH1000	72-75	1000cc 4T					H1070 H1070C		
XLH1000	72-80	1000cc 4T				5780BN 5780CN			
XLH1000	72-81	1000cc 4T				15410BN			
XLH1000	81-85	1000cc 4T				18477N 18477NC			
XLH1000	84-85	1000cc 4T					H2384		
XLH1100	86-86	1100cc 4T					H2384		
XLH1100	86-87	1100cc 4T				18477N 18477NC	H2386 H2386C		
XLH1200	88-90	1200cc 4T				18477N 18477NC	H2386 H2386C		

IT	ALTERNATORE	BOBINA	CENTRALINA	MOTORINO AVVIAMENTO	REGOLATORE	STATORE
EN	ALTERNATOR	COIL	CDI	STARTER ENGINE	RECTIFIER	STATOR
FR	ALTERNATEUR	BOBINE	BOÎTIER ÉLECTRONIQUE	DÉMARREUR ÉLECTRIQUE	RÉGULATEUR	STATOR
						

HARLEY DAVIDSON	Model	Year	Engine	Part	Part Number	Part Number
HARLEY DAVIDSON	XLH1200	91-91	1200cc 4T			H2391 H2391C
	XLH1200	91-03	1200cc 4T		18477NC	
	XLH1200	92-93	1200cc 4T			H2392 H2392C
	XLH1200	94-03	1200cc 4T			H2394 H2394C
	XLH883	86-86	883cc 4T			H2384
	XLH883	86-90	883cc 4T			H2386 H2386C
	XLH883	86-95	883cc 4T		18477N 18477NC	
	XLH883	91-91	883cc 4T			H2391 H2391C
	XLH883	91-03	883cc 4T		18477NC	
	XLH883	92-93	883cc 4T			H2392 H2392C
	XLH883	94-03	883cc 4T			H2394 H2394C
	XLH883DLX SPORTSTER 883 DELUXE	86-86	883cc 4T			H2384
	XLH883DLX SPORTSTER 883 DELUXE	86-90	883cc 4T		18477N 18477NC	H2386 H2386C
	XLH883DLX SPORTSTER 883 DELUXE	91-91	883cc 4T			H2391 H2391C
	XLH883DLX SPORTSTER 883 DELUXE	91-95	883cc 4T		18477NC	
	XLH883DLX SPORTSTER 883 DELUXE	92-93	883cc 4T			H2392 H2392C
	XLH883DLX SPORTSTER 883 DELUXE	94-95	883cc 4T			H2394 H2394C
	XLH883HUG SPORTSTER 883 HUGGER	87-90	883cc 4T		18477N 18477NC	H2386 H2386C
	XLH883HUG SPORTSTER 883 HUGGER	91-91	883cc 4T			H2391 H2391C
	XLH883HUG SPORTSTER 883 HUGGER	91-03	883cc 4T		18477NC	
XLH883HUG SPORTSTER 883 HUGGER	92-93	883cc 4T			H2392 H2392C	
XLH883HUG SPORTSTER 883 HUGGER	94-03	883cc 4T			H2394 H2394C	
XLH900	58-70	900cc 4T			5780BN 5780CN	
XLH900	71-71	1200cc 4T			5780BN 5780CN	H1070 H1070C
XLHA SPORTSTER ANN.V.	82-82	1000cc 4T			15410BN	
XLHA SPORTSTER ANN.V.	82-82	1000cc 4T			15410BN	
XLHA SPORTSTER ANN.V.	82-82	1000cc 4T			5780BN 5780CN	
XLL SPORTSTER LOW	05-07	883cc 4T			18477NC	
XLL SPORTSTER LOW	06-07	1200cc 4T			18477NC	
XLN NIGHTSTER	07-07	1200cc 4T			18477NC	

IT	ALTERNATORE	BOBINA	CENTRALINA	MOTORINO AVVIAMENTO	REGOLATORE	STATORE
EN	ALTERNATOR	COIL	CDI	STARTER ENGINE	RECTIFIER	STATOR
FR	ALTERNATEUR	BOBINE	BOÎTIER ÉLECTRONIQUE	DÉMARREUR ÉLECTRIQUE	RÉGULATEUR	STATOR
						

HARLEY DAVIDSON	Model	Year	Engine	Part	
				Code	Code
HARLEY DAVIDSON	XLR	59-60	900cc 4T		5780BN 5780CN
	XLR SPORTSTER ROADSTER	02-07	883cc 4T		18477NC
	XLR SPORTSTER ROADSTER	05-07	1200cc 4T		18477NC
	XLR1200X	11-13	1200cc 4T		H1108 H1108C
	XLRTT	58-64	900cc 4T		5780BN 5780CN
	XLS ROADSTER	79-84	1000cc 4T		15410BN
	XLS ROADSTER	79-85	1000cc 4T		5780BN 5780CN
	XLS ROADSTER	81-85	1000cc 4T		18477N 18477NC
	XLS ROADSTER	82-84	1000cc 4T		15410BN
	XLS ROADSTER	78-78	1200cc 4T		5780BN 5780CN
	XLS SPORTSTER SPORT	00-03	1200cc 4T		18477NC
	XLSA ROADSTER ANNIV.	82-82	1000cc 4T		15410BN
	XLSA ROADSTER ANNIV.	82-82	1000cc 4T		5780BN 5780CN
	XLSA ROADSTER ANNIV.	82-82	1000cc 4T		18477N 18477NC
	XLT	77-78	1200cc 4T		5780BN 5780CN
	XLX 1000	83-85	1000cc 4T		18477N 18477NC
	XLX 1000	84-85	1000cc 4T		H2384
	XLX-61	83-84	1000cc 4T		15410BN
	XLX-61	83-85	1000cc 4T		5780CN 18477NC 18477N 5780BN
	XR	69-75	750cc 4T		5780BN 5780CN
XR1000	83-84	1000cc 4T		18477NC	
XR1000	83-85	1000cc 4T		15410BN	
XR1000	83-85	1000cc 4T		18477N 5780BN 5780CN	
XR1000	84-85	1000cc 4T		H2384	
XR1000	85-85	1000cc 4T		18477NC	
XR1200	09-10	1000cc 4T		18477NC	H1108 H1108C
XR1200X	10-10	1200cc 4T			H1108 H1108C
XR1200X	10-13	1200cc 4T		18477NC	
HONDA	@ [NES]	00-06	125cc 4T LC	Honda	37046N
	@ [NES]	00-06	150cc 4T LC	Honda	37046N

IT	ALTERNATORE	BOBINA	CENTRALINA	MOTORINO AVVIAMENTO	REGOLATORE	STATORE
EN	ALTERNATOR	COIL	CDI	STARTER ENGINE	RECTIFIER	STATOR
FR	ALTERNATEUR	BOBINE	BOÎTIER ÉLECTRONIQUE	DÉMARREUR ÉLECTRIQUE	RÉGULATEUR	STATOR
						

HONDA	Model	Year	Capacity	Notes	Part Number	Part Number
	CB NIGHTHAWK	91-08	250cc 4T		18611N	
	CBR RR	06-07	1000cc 4T			27-7017
	CBR250R	11-13	250cc 4T		16071N	
	CBR300R	15-16	300cc 4T		16071N	
	CMX250C REBEL	96-15	250cc 4T		18611N	
	CRF F	03-09	230cc 4T		18850N	
	CRF X	04-09	250cc 4T		18851N	
	CRF X	12-13	250cc 4T		18851N	
	CRF X	15-15	250cc 4T		18851N	
	CRF X	05-09	450cc 4T		18852N	
	CRF X	11-15	450cc 4T		18852N	
	DYLAN [SES]	02-04	125cc 4T LC	Honda	37046N	
	DYLAN [SES]	02-04	150cc 4T LC	Honda	37046N	
	GL1100 GOLD WING	80-83	1100cc 4T		18600N	
	GL1100A GOLD WING ASPENCADE	82-83	1100cc 4T		18600N	
	GL1100I GOLD WING INTERSTATE	80-83	1100cc 4T		18600N	
	NSA DN-01	09-09	700cc 4T		19643N	
	NT V DEAUVILLE	10-11	700cc 4T		19643N	
	NT VA DEAUVILLE ABS	10-11	700cc 4T		19643N	
	NX650	88-89	650cc 4T		18671N	
	PANTHEON IE [FES]	03-05	125cc 4T-2V LC	Honda	37046N	
	PANTHEON IE [FES]	03-05	150cc 4T-2V LC	Honda	37046N	
	PC800 PACIFIC COAST	89-98	800cc 4T		18656N	
	PS I [PES]	06-10	125cc 4T LC	Honda	37046N	
	PS I [PES]	06-10	150cc 4T LC	Honda	37046N	
	SA50 ELITE LX	88-90	50cc 2T AC		19595N	
	SA50 ELITE SR	88-93	50cc 2T AC		19595N	
	SH	00-08	100cc 4T		37044N	
	SH	01-04	125cc 4T-2V LC	Honda	37046N	
	SH	01-04	150cc 4T-2V LC	Honda	37046N	

IT	ALTERNATORE	BOBINA	CENTRALINA	MOTORINO AVVIAMENTO	REGOLATORE	STATORE
EN	ALTERNATOR	COIL	CDI	STARTER ENGINE	RECTIFIER	STATOR
FR	ALTERNATEUR	BOBINE	BOÎTIER ÉLECTRONIQUE	DÉMARREUR ÉLECTRIQUE	RÉGULATEUR	STATOR
						

HONDA	Model	Year	Engine	Notes	Part Number
	SH	07-13	300cc 4T		16072N
	SH IE SCOOPIY	05-12	125cc 4T-2V LC	Honda	37046N
	SH IE SCOOPIY	05-12	150cc 4T LC	Honda	37046N
	SHADOW	10-13	50cc 4T		37044N
	SHADOW	10-13	90cc 4T		37044N
	SILVER WING ABS	03-13	600cc 4T		18859N
	SILVER WING [FES]	07-12	125cc 4T-2V LC	Honda	37046N
	SILVER WING [FES]	07-12	150cc 4T-2V LC	(KF06E)	37046N
	SILVER WING [FJS]	02-10	600cc 4T		18859N
	ST	91-03	1100cc 4T		18657N
	ST ABS	92-03	1100cc 4T		18657N
	VF700C MAGNA	84-86	700cc 4T		18660N
	VF700C MAGNA	87-87	700cc 4T		18660N
	VF700F INTERCEPTOR	84-85	700cc 4T		18661N
	VF700S SABRE	84-85	700cc 4T		18660N
	VF750C MAGNA	88-88	750cc 4T		18660N
	VF750C V45 MAGNA	82-83	750cc 4T		18660N
	VF750F V45 INTERCEPTOR	83-84	750cc 4T		18661N
	VF750S V45 SABRE	82-83	750cc 4T		18660N
	VT C SHADOW AERO	08-15	750cc 4T		19643N
	VT C2 SHADOW SPIRIT	07-15	750cc 4T		19643N
	VT C2 SHADOW SPIRIT ABS	13-14	750cc 4T		19643N
	VT C2B SHADOW PHAMTON	12-15	750cc 4T		19643N
	VT CA SHADOW AERO ABS	12-14	750cc 4T		19643N
	VT RS SHADOW	13-13	750cc 4T		19643N
	VT1100C SHADOW	95-96	1100cc 4T		18656N
	VT1100C SHADOW SPIRIT	97-07	1100cc 4T		18656N
	VT1100C2 SHADOW SABRE	04-07	1100cc 4T		18656N
	XR650L	93-09	650cc 4T		18671N
	XR650L	12-15	650cc 4T		18671N

IT	ALTERNATORE	BOBINA	CENTRALINA	MOTORINO AVVIAMENTO	REGOLATORE	STATORE
EN	ALTERNATOR	COIL	CDI	STARTER ENGINE	RECTIFIER	STATOR
FR	ALTERNATEUR	BOBINE	BOÎTIER ÉLECTRONIQUE	DÉMARREUR ÉLECTRIQUE	RÉGULATEUR	STATOR
						

HUSQVARNA	HUV-4421-DXP	06-10	720cc 4T				19162N		
	KAWASAKI	EN450A 454 LTD	85-90	450cc 4T				18704N	
EX500		87-93	500cc 4T				18704N		
EX500 NINJA 500		94-96	500cc 4T				18704N		
EX500 NINJA 500R		97-09	500cc 4T				18704N		
KFX400		03-06	400cc 4T				18718N		
KL250 SUPER SHERPA		00-10	250cc 4T				18715N		
KL650B TENGAI		90-91	650cc 4T				18690N		
KLF220 BAYOU		88-02	220cc 4T				18716N		
KLF250 BAYOU		03-11	250cc 4T				18716N		
KLF400 BAYOU 4X4		93-99	400cc 4T				18702N		
KLR650		87-10	650cc 4T				18690N		
KLR650		11-15	650cc 4T				18690N		
KLX250S		06-07	250cc 4T				18715N		
KLX400R		03-03	400cc 4T				18718N		
KLX400SR		03-03	400cc 4T				18718N		
KVF400 PRAIRIE 2X4		98-99	400cc 4T				18702N		
KVF400 PRAIRIE 2X4		00-02	400cc 4T				18702N		
KVF400 PRAIRIE 4X4		97-02	400cc 4T				18702N		
NINJA ZX-6R		03-06	636cc 4T				18833N		
NINJA ZX-6RR		03-06	600cc 4T				18833N		
VN A VULCAN		04-09	2000cc 4T				18837N		
VN CLASSIC		06-10	900cc 4T			CPS28			
VN CLASSIC	06-10	900cc 4T			CPS28				
VN CLASSIC	11-12	900cc 4T			CPS28				
VN CLASSIC	13-14	900cc 4T			CPS28				
VN CLASSIC	09-09	1700cc 4T			CPS28				
VN CUSTOM	07-11	900cc 4T			CPS28				
VN D VULCAN	05-06	2000cc 4T				18837N			
VN E VULCAN	06-09	2000cc 4T				18837N			

IT	ALTERNATORE	BOBINA	CENTRALINA	MOTORINO AVVIAMENTO	REGOLATORE	STATORE
EN	ALTERNATOR	COIL	CDI	STARTER ENGINE	RECTIFIER	STATOR
FR	ALTERNATEUR	BOBINE	BOÎTIER ÉLECTRONIQUE	DÉMARREUR ÉLECTRIQUE	RÉGULATEUR	STATOR
						

KAWASAKI	VN F VULCAN	06-10	2000cc 4T				18837N	
	VN VULCAN CLASSIC	15-16	900cc 4T		CPS28			
	VN VULCAN CUSTOM	12-15	900cc 4T		CPS28			
	VN VULCAN CUSTOM	16-16	900cc 4T		CPS28			
	VN1500A VULCAN 1500	96-99	1500cc 4T				18692N	
	VN1500A VULCAN 88	87-95	1500cc 4T				18692N	
	VN1500B VULCAN 88 SE	87-90	1500cc 4T				18692N	
	VN1500C VULCAN L	96-97	1500cc 4T				18692N	
	VN1500E VULCAN 1500 CLASSIC	96-08	1500cc 4T				18692N	
	VN1500G VULCAN 1500 NOMAD	99-01	1500cc 4T				18692N	
	VN1500J/R VULCAN 1500 DRIFTER	99-05	1500cc 4T				18692N	
	VN1500L VULCAN NOMAD FI	00-04	1500cc 4T				18692N	
	VN1500N VULCAN 1500 CLASSIC FI	00-02	1500cc 4T				18692N	
	VN1500P VULCAN 1500 MEAN STREAK	02-03	1500cc 4T				18692N	
	VN1600A VULCAN 1600 CLASSIC	03-08	1600cc 4T				18692N	
	VN1600B VULCAN 1600 MEAN STREAK	04-08	1600cc 4T				18692N	
	VN1600D VULCAN 1600 NOMAD	05-08	1600cc 4T				18692N	
	ZG1200 VOYAGER XII	86-86	1200cc 4T		12481N			
	ZG1200 VOYAGER XII	87-91	1200cc 4T		12481N			
	ZG1200 VOYAGER XII	92-03	1200cc 4T		12481N			
ZR ZEPHIR A1-A4	92-95	1100cc 4T		12481N				
ZX-10R NINJA	04-06	1000cc 4T				18836N		
ZX-9R	98-03	900cc 4T				18788N		
KTM	ADVENTURE	98-08	640cc 4T				19633N	
	COMP LIMITED	97-97	620cc 4T				19633N	
	DUKE	96-97	620cc 4T				19633N	
	DUKE	98-98	640cc 4T				19633N	
	DUKE II	99-06	640cc 4T				19633N	
	EGS	94-97	620cc 4T				19633N	
	EGS-E	97-97	620cc 4T				19633N	

IT	ALTERNATORE	BOBINA	CENTRALINA	MOTORINO AVVIAMENTO	REGOLATORE	STATORE
EN	ALTERNATOR	COIL	CDI	STARTER ENGINE	RECTIFIER	STATOR
FR	ALTERNATEUR	BOBINE	BOÎTIER ÉLECTRONIQUE	DÉMARREUR ÉLECTRIQUE	RÉGULATEUR	STATOR
						

KTM									
	Model	Year	Capacity	Part No.	Part No.	Part No.	Part No.	Part No.	Part No.
	ENDURO	99-02	640cc 4T				19633N		
	EXC	00-06	400cc 4T				19620N		
	EXC	03-05	450cc 4T				19620N		
	EXC	12-14	500cc 4T				11835N		
	EXC	00-02	520cc 4T				19620N		
	EXC	03-06	525cc 4T				19620N		
	EXC	94-97	620cc 4T				19633N		
	EXC R	08-11	450cc 4T				19620N		
	EXC SIX DAYS	12-12	500cc 4T				11835N		
	EXC-F	12-14	350cc 4T				11834N		
	EXC-G	06-07	525cc 4T				19620N		
	FREERIDE	12-12	350cc 4T				11834N		
	LC4	98-01	400cc 4T				19633N		
	LC4 EXC	94-97	620cc 4T				19633N		
	LC4 SX	97-98	620cc 4T				19633N		
	LSE	97-98	400cc 4T				19633N		
	MXC	01-02	400cc 4T				19620N		
	MXC	03-05	450cc 4T				19620N		
	MXC	00-02	520cc 4T				19620N		
	MXC	03-05	525cc 4T				19620N		
	RALLY	00-06	660cc 4T				19633N		
	RXC	96-98	400cc 4T				19633N		
	RXC	95-98	620cc 4T				19633N		
	SC	94-01	620cc 4T				19633N		
	SMC	04-06	625cc 4T				19633N		
	SMC	02-06	660cc 4T				19633N		
	SMR	05-06	450cc 4T				19620N		
	SMR	04-06	525cc 4T				19620N		
	SMS	04-04	450cc 4T				19620N		
	SMS	04-04	660cc 4T				19633N		

IT	ALTERNATORE	BOBINA	CENTRALINA	MOTORINO AVVIAMENTO	REGOLATORE	STATORE
EN	ALTERNATOR	COIL	CDI	STARTER ENGINE	RECTIFIER	STATOR
FR	ALTERNATEUR	BOBINE	BOÎTIER ÉLECTRONIQUE	DÉMARREUR ÉLECTRIQUE	RÉGULATEUR	STATOR
						

KTM									
	Model	Year	Capacity	Part No.	Part No.	Part No.	Part No.	Part No.	Part No.
	SUPER MOTO	98-01	620cc 4T				19633N		
	SUPERMOTO	99-05	640cc 4T				19633N		
	SX	00-02	400cc 4T				19620N		
	SX	00-02	520cc 4T				19620N		
	SX	03-06	525cc 4T				19620N		
	SX	96-99	620cc 4T				19633N		
	SX-F	12-14	250cc 4T				11834N		
	SX-F	11-14	350cc 4T				11834N		
	SX-F	03-06	450cc 4T				19620N		
	SX-F	13-13	450cc 4T				11835N		
	SX-F	14-14	450cc 4T				11834N		
	SX-F FACTORY EDITION	13-13	450cc 4T				11835N		
	SXC	00-06	540cc 4T				19620N		
	SXC	97-97	620cc 4T				19633N		
	SXC	03-04	625cc 4T				19633N		
	SXS	03-06	450cc 4T				19620N		
	TXC	98-98	400cc 4T				19633N		
	TXC	98-98	620cc 4T				19633N		
	XC	09-14	250cc 4T				19091N		
	XC	08-14	300cc 4T				19091N		
	XC	08-10	450cc 4T				19620N		
	XC	08-10	525cc 4T				19620N		
	XC-F	12-14	350cc 4T				11834N		
	XC-F	06-06	450cc 4T				19620N		
	XC-F	13-14	450cc 4T				11835N		
	XC-G	06-07	525cc 4T				19620N		
	XC-W	08-14	250cc 4T				19091N		
	XC-W	08-14	300cc 4T				19091N		
	XC-W	07-10	400cc 4T				19620N		
	XC-W	06-11	450cc 4T				19620N		

IT	ALTERNATORE	BOBINA	CENTRALINA	MOTORINO AVVIAMENTO	REGOLATORE	STATORE
EN	ALTERNATOR	COIL	CDI	STARTER ENGINE	RECTIFIER	STATOR
FR	ALTERNATEUR	BOBINE	BOÎTIER ÉLECTRONIQUE	DÉMARREUR ÉLECTRIQUE	RÉGULATEUR	STATOR
						

KTM	XC-W	12-14	450cc 4T				11835N		
	XC-W	12-14	500cc 4T				11835N		
	XC-W	07-07	525cc 4T				19620N		
KYMCO	XCF-W	12-14	350cc 4T				11834N		
	B&W	02-02	50cc 2T LC	Motore Kymco			19597N		
	B&W	02-02	50cc 2T LC	Motore Kymco			37010N		
	B&W	00-00	250cc 4T LC				37009N		
	B&W EU2	03-03	50cc 2T LC	Motore Kymco			19597N		
	B&W EU2	03-03	50cc 2T LC	Motore Kymco			37010N		
	B&W EU2	03-03	250cc 4T LC				37009N		
	CX	93-93	50cc 2T AC	Motore Kymco			19595N		
	CX SUPER	94-97	50cc 2T AC	Motore Kymco			19595N		
	DINK LC	98-02	50cc 2T LC	Motore Kymco			19597N		
	DINK LC	98-02	50cc 2T LC	Motore Kymco			37010N		
	DINK CLASSIC EU2	03-03	50cc 2T AC	Motore Kymco			19597N		
	DINK CLASSIC EU2	03-03	50cc 2T AC	Motore Kymco			37010N		
	DINK EU3	06-07	125cc 4T LC				37045N		
	DINK EU3	06-07	125cc 4T LC					KW1009N	
	DINK IE EU3	06-07	200cc 4T LC					KW1009N	
	DJ WORLD	94-00	50cc 2T AC	Motore Kymco			19595N		
	DJ X	91-92	50cc 2T AC	Motore Kymco			19595N		
	DJ Y	93-93	50cc 2T AC	Motore Kymco			19595N		
	DOWNTOWN ABS	10-10	300cc 4T LC					KW1009N	
	DOWNTOWN I	09-16	125cc 4T LC					KW1009N	
	DOWNTOWN I	10-10	200cc 4T LC					KW1009N	
	DOWNTOWN I	09-09	300cc 4T LC					KW1009N	
	DOWNTOWN I	11-11	300cc 4T LC					KW1009N	
	DOWNTOWN I ABS	11-16	300cc 4T LC					KW1009N	
	G-DINK	12-12	125cc 4T LC				37045N		
	G-DINK	12-12	300cc 4T-2V LC				37009N		

IT	ALTERNATORE	BOBINA	CENTRALINA	MOTORINO AVVIAMENTO	REGOLATORE	STATORE
EN	ALTERNATOR	COIL	CDI	STARTER ENGINE	RECTIFIER	STATOR
FR	ALTERNATEUR	BOBINE	BOÎTIER ÉLECTRONIQUE	DÉMARREUR ÉLECTRIQUE	RÉGULATEUR	STATOR
						

KYMCO								
	Model	Year	Engine	Motor	Part No.	Part No.	Part No.	Part No.
	G-DINK I ABS E4	17-17	300cc 4T-2V LC				37009N	
	GRAND DINK	01-02	125cc 4T LC				37045N	
	GRAND DINK	01-02	150cc 4T LC				37045N	
	GRAND DINK	01-02	250cc 4T LC				37009N	
	GRAND DINK EU2	03-04	125cc 4T LC				37045N	
	GRAND DINK EU2	03-04	150cc 4T LC				37045N	
	GRAND DINK EU2	03-04	250cc 4T LC				37009N	
	HEROISM	95-97	50cc 2T AC	Motore Kymco			19597N	
	HEROISM	95-97	50cc 2T AC	Motore Kymco			37010N	
	K 12	95-00	50cc 2T AC	Motore Kymco			19595N	
	KB	95-00	50cc 2T AC	Motore Kymco			19595N	
	KXR	04-04	50cc 2T AC				19597N	
	KXR	04-04	50cc 2T AC				37010N	
	MAXXER	05-05	50cc 2T AC				19597N	
	MAXXER	05-05	50cc 2T AC				37010N	
	MXER	02-03	50cc 2T AC				19597N	
	MXER	02-03	50cc 2T AC				37010N	
	MXER EU2	04-04	50cc 2T AC				19597N	
	MXER EU2	04-04	50cc 2T AC				37010N	
	MXU	06-07	50cc 2T AC				19597N	
	MXU	06-07	50cc 2T AC				37010N	
	MXU	05-06	500cc 4T				19228N	
	MXU IRS	10-10	500cc 4T				19228N	
	MXU SR	06-06	50cc 2T AC				19597N	
	MXU SR	06-06	50cc 2T AC				37010N	
	PEOPLE	99-03	50cc 2T AC	Motore Kymco			19597N	
	PEOPLE	99-03	50cc 2T AC	Motore Kymco			37010N	
	PEOPLE	04-04	50cc 2T AC	Motore Kymco			19597N	
	PEOPLE	04-04	50cc 2T AC	Motore Kymco			37010N	
	PEOPLE EURO 2	03-03	50cc 2T AC	Motore Kymco			19597N	

IT	ALTERNATORE	BOBINA	CENTRALINA	MOTORINO AVVIAMENTO	REGOLATORE	STATORE
EN	ALTERNATOR	COIL	CDI	STARTER ENGINE	RECTIFIER	STATOR
FR	ALTERNATEUR	BOBINE	BOÎTIER ÉLECTRONIQUE	DÉMARREUR ÉLECTRIQUE	RÉGULATEUR	STATOR
						

KYMCO	Model	Year	Engine	Motor	Part Number	Accessories
PEOPLE EURO 2	03-03	50cc 2T AC	Motore Kymco		37010N	
PEOPLE EURO 2	08-08	50cc 2T AC	Motore Kymco		19597N	
PEOPLE EURO 2	08-08	50cc 2T AC	Motore Kymco		37010N	
PEOPLE EURO 2	11-11	50cc 2T AC	Motore Kymco		19597N	
PEOPLE EURO 2	11-11	50cc 2T AC	Motore Kymco		37010N	
PEOPLE GTI	10-10	125cc 4T LC				KW1009N
PEOPLE GTI	14-14	125cc 4T LC				KW1009N
PEOPLE GTI	10-10	200cc 4T LC				KW1009N
PEOPLE GTI	14-14	200cc 4T LC				KW1009N
PEOPLE GTI	10-10	300cc 4T LC				KW1009N
PEOPLE GTI	11-11	300cc 4T LC				KW1009N
PEOPLE GTI	14-14	300cc 4T LC				KW1009N
PEOPLE GTI ABS	12-12	300cc 4T LC				KW1009N
PEOPLE GTI ABS	14-14	300cc 4T LC				KW1009N
PEOPLE GTI ABS E4	16-16	300cc 4T LC				KW1009N
PEOPLE LC	03-04	250cc 4T LC			37009N	
PEOPLE S	05-08	50cc 2T AC	Motore Kymco		19597N	
PEOPLE S	05-08	50cc 2T AC	Motore Kymco		37010N	
PEOPLE S	06-06	250cc 4T LC			37009N	
PEOPLE S I	07-07	250cc 4T LC			37009N	
PEOPLE S I	07-07	250cc 4T LC				KW1009N
PEOPLE S I	08-08	300cc 4T LC	(BB60)		37009N	
PEOPLE S I	08-08	300cc 4T LC	(BB60)			KW1009N
SNIPER	93-93	50cc 2T AC	Motore Kymco		19597N	
SNIPER	93-93	50cc 2T AC	Motore Kymco		37010N	
SNIPER DD	94-96	50cc 2T AC	Motore Kymco		19597N	
SNIPER DD	94-96	50cc 2T AC	Motore Kymco		37010N	
SUPER 9	00-00	50cc 2T LC	Motore Kymco		19597N	
SUPER 9	00-00	50cc 2T LC	Motore Kymco		37010N	
SUPER 9 EU2	03-03	50cc 2T LC	Motore Kymco		19597N	

IT	ALTERNATORE	BOBINA	CENTRALINA	MOTORINO AVVIAMENTO	REGOLATORE	STATORE
EN	ALTERNATOR	COIL	CDI	STARTER ENGINE	RECTIFIER	STATOR
FR	ALTERNATEUR	BOBINE	BOÎTIER ÉLECTRONIQUE	DÉMARREUR ÉLECTRIQUE	RÉGULATEUR	STATOR
						

KYMC0	Model	Year	Capacity	Motor	Part No.	Part No.	Part No.
	SUPER 9 EU2	03-03	50cc 2T LC	Motore Kymco	37010N		
	SUPER 9 EU2	04-04	50cc 2T LC	Motore Kymco	19597N		
	SUPER 9 EU2	04-04	50cc 2T LC	Motore Kymco	37010N		
	TOP BOY	97-00	50cc 2T AC	Motore Kymco	19597N		
	TOP BOY	97-00	50cc 2T AC	Motore Kymco	37010N		
	UXV	08-08	500cc 4T		19228N		
	UXV I	10-10	500cc 4T		19228N		
	VENOX	02-03	250cc 4T LC			KW1009N	
	VENOX EURO2	04-04	250cc 4T LC			KW1009N	
	VENOX EURO3	07-07	250cc 4T LC			KW1009N	
	VITALITY 2T	04-04	50cc 2T AC	Motore Kymco	19597N		
	VITALITY 2T	04-04	50cc 2T AC	Motore Kymco	37010N		
	X CITING	05-05	500cc 4T		19228N		
	X CITING	05-05	500cc 4T LC			KW1009N	
	X CITING I	06-07	250cc 4T LC		37009N		
	X CITING I	06-07	250cc 4T LC			KW1009N	
	X CITING I	08-08	300cc 4T LC		37009N		
	X CITING I	08-08	300cc 4T LC			KW1009N	
	X CITING I	06-07	500cc 4T		19228N		
	X CITING I	08-08	500cc 4T		19228N		
	X CITING I R	08-08	300cc 4T LC		37009N		
	X CITING I R	08-08	300cc 4T LC			KW1009N	
	X CITING I R	09-09	300cc 4T LC		37009N		
	X CITING I R	09-09	300cc 4T LC			KW1009N	
	X CITING I R	07-08	500cc 4T		19228N		
	X CITING R	09-09	500cc 4T		19228N		
	YUP	02-02	50cc 2T AC	Motore Kymco	19597N		
	YUP	02-02	50cc 2T AC	Motore Kymco	37010N		
	YUP	03-03	250cc 4T LC	(SH50D)	37009N		
	YUP EU2	03-03	50cc 2T AC	Motore Kymco	19597N		

IT	ALTERNATORE	BOBINA	CENTRALINA	MOTORINO AVVIAMENTO	REGOLATORE	STATORE
EN	ALTERNATOR	COIL	CDI	STARTER ENGINE	RECTIFIER	STATOR
FR	ALTERNATEUR	BOBINE	BOÎTIER ÉLECTRONIQUE	DÉMARREUR ÉLECTRIQUE	RÉGULATEUR	STATOR
						

KYMCO	YUP EU2	03-03	50cc 2T AC	Motore Kymco				37010N	
	PEUGEOT	ELISTAR	03-05	50cc 2T				16091N	
	JET FORCE	03-06	50cc 2T					16091N	
	LOOXOR TDSI	02-06	50cc 2T					16091N	
PIAGGIO	APE	09-11	50cc 2T AC					37034N	
	APE	12-17	50cc 2T AC					37034N	
	APE EU4	18-18	50cc 2T LC					37034N	
	APE FL - FL2	89-95	50cc 2T AC					37034N	
	APE FL3 EUROPA	96-99	50cc 2T AC					37034N	
	APE MIX 2T	98-08	50cc 2T AC					37034N	
	APE RST MIX	99-03	50cc 2T AC					37034N	
	APE TM P	85-89	50cc 2T AC					37034N	
	BEVERLY	01-03	125cc 4T LC					19588N	
	BEVERLY	01-03	125cc 4T LC					37033N	
	BEVERLY	02-04	500cc 4T LC					16073N	
	BEVERLY	05-06	500cc 4T LC	Piaggio				16073N	
	BEVERLY EU3	06-07	400cc 4T LC	Piaggio M345M				16073N	
	BEVERLY CRUISER	07-12	500cc 4T LC	Piaggio Master				16073N	
	BEVERLY EU3	07-08	125cc 4T LC					19588N	
	BEVERLY EU3	07-08	125cc 4T LC					37033N	
	BEVERLY EURO 3 MIC	07-07	125cc 4T LC					19588N	
	BEVERLY EURO 3 MIC	07-07	125cc 4T LC					37033N	
	BEVERLY EURO 3 SPORT	07-08	125cc 4T LC					19588N	
	BEVERLY EURO 3 SPORT	07-08	125cc 4T LC					37033N	
	BEVERLY IE EU3	06-08	500cc 4T LC	Piaggio M343M				16073N	
	BEVERLY RST	04-05	125cc 4T LC					19588N	
	BEVERLY RST	04-05	125cc 4T LC	M28400				37033N	
	BEVERLY RST	05-07	125cc 4T LC					19588N	
	BEVERLY RST	05-07	125cc 4T LC					37033N	
	BEVERLY TOURER EU3	07-10	125cc 4T LC					19588N	

IT	ALTERNATORE	BOBINA	CENTRALINA	MOTORINO AVVIAMENTO	REGOLATORE	STATORE
EN	ALTERNATOR	COIL	CDI	STARTER ENGINE	RECTIFIER	STATOR
FR	ALTERNATEUR	BOBINE	BOÎTIER ÉLECTRONIQUE	DÉMARREUR ÉLECTRIQUE	RÉGULATEUR	STATOR
						

PIAGGIO	Model	Year	Engine	Accessories	Part Number	Part Number	Part Number	Part Number	Part Number
	BEVERLY TOURER EU3	07-10	125cc 4T LC					37033N	
	BEVERLY TOURER EU3	08-10	400cc 4T LC	Piaggio M349M				16073N	
	CARNABY	07-10	125cc 4T LC					19588N	
	CARNABY	07-10	125cc 4T LC	Leader M28FM				37033N	
	CARNABY	07-08	200cc 4T LC					19588N	
	CARNABY	07-08	200cc 4T LC	Leader M601M				37033N	
	FLY	06-07	100cc 4T AC					16088N	
	FLY	08-14	100cc 4T AC					16088N	
	FLY	05-07	125cc 4T AC					19588N	
	FLY	05-07	125cc 4T AC	Leader M422M				37033N	
	FLY	05-07	150cc 4T AC					19588N	
	FLY	05-07	150cc 4T AC	Leader M422M				37033N	
	FLY EU3	07-07	125cc 4T AC					19588N	
	FLY EU3	07-07	125cc 4T AC					37033N	
	FLY EU3	08-11	125cc 4T AC					19588N	
	FLY EU3	08-11	125cc 4T AC					37033N	
	FLY EU3	08-11	150cc 4T AC					19588N	
	FLY EU3	08-11	150cc 4T AC					37033N	
	FREE	02-03	100cc 4T AC					16088N	
	HEXAGON GTX	00-00	125cc 4T LC					19588N	
	HEXAGON GTX	00-00	125cc 4T LC					37033N	
	HEXAGON GTX	00-00	180cc 4T LC					19588N	
	HEXAGON GTX	00-00	180cc 4T LC					37033N	
	HEXAGON LXT180	98-99	180cc 2T LC					16088N	
	LIBERTY	01-02	125cc 4T AC					19588N	
	LIBERTY	01-02	125cc 4T AC	Leader				37033N	
	LIBERTY	06-06	200cc 4T AC					19588N	
	LIBERTY	06-06	200cc 4T AC					37033N	
	LIBERTY 4T	06-07	125cc 4T AC					19588N	
	LIBERTY 4T	06-07	125cc 4T AC					37033N	

IT	ALTERNATORE	BOBINA	CENTRALINA	MOTORINO AVVIAMENTO	REGOLATORE	STATORE
EN	ALTERNATOR	COIL	CDI	STARTER ENGINE	RECTIFIER	STATOR
FR	ALTERNATEUR	BOBINE	BOÎTIER ÉLECTRONIQUE	DÉMARREUR ÉLECTRIQUE	RÉGULATEUR	STATOR
						

PIAGGIO	Model	Year	Engine	Accessories	Part Number	Part Number	Part Number
	LIBERTY 4T 2V EURO3	09-12	125cc 4T AC		19588N		
	LIBERTY 4T 2V EURO3	09-12	125cc 4T AC		37033N		
	LIBERTY 4T EU3	06-08	125cc 4T AC		19588N		
	LIBERTY 4T EU3	06-08	125cc 4T AC		37033N		
	LIBERTY 4T EU3	08-08	150cc 4T AC		19588N		
	LIBERTY 4T EU3	08-08	150cc 4T AC		37033N		
	LIBERTY 4T EU3	06-08	200cc 4T AC		19588N		
	LIBERTY 4T EU3	06-08	200cc 4T AC		37033N		
	LIBERTY 4T EU3 DELIVERY - TNT	08-15	125cc 4T AC		19588N		
	LIBERTY 4T EU3 DELIVERY - TNT	08-15	125cc 4T AC		37033N		
	LIBERTY 4T SPORT EU3	06-08	125cc 4T AC		19588N		
	LIBERTY 4T SPORT EU3	06-08	125cc 4T AC		37033N		
	LIBERTY 4T SPORT EU3	08-08	150cc 4T AC		19588N		
	LIBERTY 4T SPORT EU3	08-08	150cc 4T AC		37033N		
	LIBERTY 4T SPORT EU3	06-07	200cc 4T AC		19588N		
	LIBERTY 4T SPORT EU3	06-07	200cc 4T AC	Leader	37033N		
	LIBERTY MOC 4T	09-13	150cc 4T AC		19588N		
	LIBERTY MOC 4T	09-13	150cc 4T AC		37033N		
	LIBERTY RST	04-05	125cc 4T AC		19588N		
	LIBERTY RST	04-05	125cc 4T AC		37033N		
	LIBERTY RST	04-04	200cc 4T AC		19588N		
	LIBERTY RST	04-04	200cc 4T AC		37033N		
	LIBERTY SPORT	06-06	125cc 4T AC		19588N		
	LIBERTY SPORT	06-06	125cc 4T AC		37033N		
	LIBERTY SPORT	06-06	200cc 4T AC		19588N		
	LIBERTY SPORT	06-06	200cc 4T AC		37033N		
	MP3	06-08	125cc 4T LC		19588N		
	MP3	06-08	125cc 4T LC	Piaggio M631M	37033N		
	MP3	07-08	400cc 4T LC	Piaggio M474M	16073N		
	MP3 IE LT TOURING	11-11	400cc 4T LC		16073N		

IT	ALTERNATORE	BOBINA	CENTRALINA	MOTORINO AVVIAMENTO	REGOLATORE	STATORE
EN	ALTERNATOR	COIL	CDI	STARTER ENGINE	RECTIFIER	STATOR
FR	ALTERNATEUR	BOBINE	BOÎTIER ÉLECTRONIQUE	DÉMARREUR ÉLECTRIQUE	RÉGULATEUR	STATOR
						

PIAGGIO	Model	Year	Engine						
	MP3 IE LT/SPORT	08-10	400cc 4T LC					16073N	
	MP3 LT BUSINESS ABS	14-16	500cc 4T LC					16073N	
	MP3 LT E4 SPORT/BUSINESS	16-17	500cc 4T LC					16073N	
	MP3 LT SPORT/BUSINESS	11-13	500cc 4T LC					16073N	
	MP3 MIC	08-10	400cc 4T LC					16073N	
	MP3 RL SPORT-BUSINESS	11-12	500cc 4T LC					16073N	
	MP3 RL TOURING	11-11	400cc 4T LC					16073N	
	MP3 SPORT ABS	14-16	500cc 4T LC					16073N	
	SKYPPER 4T	00-02	125cc 4T AC					19588N	
	SKYPPER 4T	00-02	125cc 4T AC					37033N	
	SKYPPER 4T	00-02	150cc 4T AC					19588N	
	SKYPPER 4T	00-02	150cc 4T AC					37033N	
	SUPER HEXAGON GTX 12	01-02	125cc 4T LC					19588N	
	SUPER HEXAGON GTX 12	01-02	125cc 4T LC					37033N	
	SUPER HEXAGON GTX 12	01-02	180cc 4T LC					19588N	
	SUPER HEXAGON GTX 12	01-02	180cc 4T LC					37033N	
	TYPHOON 4T 2V E3	10-11	125cc 4T AC					19588N	
	TYPHOON 4T 2V E3	10-11	125cc 4T AC					37033N	
	VESPA ET4	99-02	125cc 4T AC					19588N	
	VESPA ET4	99-02	125cc 4T AC	Leader				37033N	
	VESPA ET4	99-02	150cc 4T AC					19588N	
	VESPA ET4	99-02	150cc 4T AC	Leader				37033N	
	VESPA FL	90-90	50cc 2T AC					37034N	
	VESPA FL	89-90	125cc 2T AC					37034N	
	VESPA FL2 AUTOMATICA	90-91	50cc 2T AC					37034N	
	VESPA FL2 HP	91-97	50cc 2T AC					37034N	
	VESPA GRANTURISMO	03-05	125cc 4T LC					19588N	
	VESPA GRANTURISMO	03-05	125cc 4T LC	Piaggio M311M				37033N	
	VESPA GRANTURISMO	06-07	125cc 4T LC					19588N	
	VESPA GRANTURISMO	06-07	125cc 4T LC					37033N	

IT	ALTERNATORE	BOBINA	CENTRALINA	MOTORINO AVVIAMENTO	REGOLATORE	STATORE
EN	ALTERNATOR	COIL	CDI	STARTER ENGINE	RECTIFIER	STATOR
FR	ALTERNATEUR	BOBINE	BOÎTIER ÉLECTRONIQUE	DÉMARREUR ÉLECTRIQUE	RÉGULATEUR	STATOR
						

PIAGGIO	Model	Year	Engine	Accessories	Part Number	Part Number	Part Number	Part Number	Part Number
	VESPA GRANTURISMO	03-05	200cc 4T LC					19588N	
	VESPA GRANTURISMO	03-05	200cc 4T LC					37033N	
	VESPA GRANTURISMO	06-07	200cc 4T LC					19588N	
	VESPA GRANTURISMO	06-07	200cc 4T LC					37033N	
	VESPA GRANTURISMO EU3	06-07	125cc 4T LC					19588N	
	VESPA GRANTURISMO EU3	06-07	125cc 4T LC	Piaggio M314M				37033N	
	VESPA GTS EU3	07-12	125cc 4T LC					19588N	
	VESPA GTS EU3	07-12	125cc 4T LC	Piaggio M315M				37033N	
	VESPA GTV	06-08	125cc 4T LC					19588N	
	VESPA GTV	06-08	125cc 4T LC					37033N	
	VESPA GTV 4T NAVY EU3	08-08	125cc 4T LC					19588N	
	VESPA GTV 4T NAVY EU3	08-08	125cc 4T LC					37033N	
	VESPA LX	05-06	125cc 4T AC					19588N	
	VESPA LX	05-06	125cc 4T AC					37033N	
	VESPA LX	05-06	150cc 4T AC					19588N	
	VESPA LX	05-06	150cc 4T AC					37033N	
	VESPA LX 4T EU3 TOURING	10-11	125cc 4T AC					19588N	
	VESPA LX 4T EU3 TOURING	10-11	125cc 4T AC					37033N	
	VESPA LX 4T FL	09-09	125cc 4T AC					19588N	
	VESPA LX 4T FL	09-09	125cc 4T AC					37033N	
	VESPA LX 4T FL	09-09	150cc 4T AC					19588N	
	VESPA LX 4T FL	09-09	150cc 4T AC					37033N	
	VESPA LX EU3	06-08	125cc 4T AC					19588N	
	VESPA LX EU3	06-08	125cc 4T AC					37033N	
	VESPA LX EU3	06-08	150cc 4T AC					19588N	
	VESPA LX EU3	06-08	150cc 4T AC					37033N	
	VESPA LX EU3 IE	09-11	125cc 4T AC					19588N	
	VESPA LX EU3 IE	09-11	125cc 4T AC					37033N	
	VESPA LX EU3 IE	09-11	150cc 4T AC					19588N	
	VESPA LX EU3 IE	09-11	150cc 4T AC					37033N	

IT	ALTERNATORE	BOBINA	CENTRALINA	MOTORINO AVVIAMENTO	REGOLATORE	STATORE
EN	ALTERNATOR	COIL	CDI	STARTER ENGINE	RECTIFIER	STATOR
FR	ALTERNATEUR	BOBINE	BOÎTIER ÉLECTRONIQUE	DÉMARREUR ÉLECTRIQUE	RÉGULATEUR	STATOR
						

PIAGGIO	Model	Year	Engine	Part	Code	Code	Code	Code	Code
	VESPA LX TOURING	10-12	150cc 4T AC					19588N	
	VESPA LX TOURING	10-12	150cc 4T AC					37033N	
	VESPA LXV 4T EU3	06-09	125cc 4T LC					19588N	
	VESPA LXV 4T EU3	06-09	125cc 4T LC					37033N	
	VESPA LXV IE 4T	10-13	125cc 4T LC					19588N	
	VESPA LXV IE 4T	10-13	125cc 4T LC					37033N	
	VESPA LXV NAVY EU3	07-08	125cc 4T LC					19588N	
	VESPA LXV NAVY EU3	07-08	125cc 4T LC					37033N	
	VESPA N	89-90	50cc 2T AC					37034N	
	VESPA PK	82-84	50cc 2T AC					37034N	
	VESPA PK AUTOMATICA	84-89	50cc 2T AC					37034N	
	VESPA PK XL	85-88	50cc 2T AC					37034N	
	VESPA PK XL PLURIMATIC	85-90	50cc 2T AC					37034N	
	VESPA PK XL RUSH	88-89	50cc 2T AC					37034N	
	VESPA S 4T	08-09	150cc 4T AC					19588N	
	VESPA S 4T	08-09	150cc 4T AC	Piaggio M445M				37033N	
	VESPA S 4T EU3	07-08	125cc 4T AC					19588N	
	VESPA S 4T EU3	07-08	125cc 4T AC	Piaggio M444M				37033N	
	VESPA S 4T IE & COLLEGE	09-11	125cc 4T AC					19588N	
	VESPA S 4T IE & COLLEGE	09-11	125cc 4T AC					37033N	
	VESPA S 4T IE & COLLEGE	09-12	150cc 4T AC					19588N	
	VESPA S 4T IE & COLLEGE	09-12	150cc 4T AC					37033N	
	X-EVO	07-16	125cc 4T LC					19588N	
	X-EVO	07-16	125cc 4T LC					37033N	
	X-EVO	07-11	400cc 4T LC	Piaggio M521M				16073N	
	X10 4T-4V IE EU3	12-14	500cc 4T LC					16073N	
	X7 EU3	08-08	125cc 4T LC					19588N	
	X7 EU3	08-08	125cc 4T LC	Leader				37033N	
	X8	04-04	125cc 4T LC					19588N	
	X8	04-04	125cc 4T LC	Leader				37033N	

IT	ALTERNATORE	BOBINA	CENTRALINA	MOTORINO AVVIAMENTO	REGOLATORE	STATORE
EN	ALTERNATOR	COIL	CDI	STARTER ENGINE	RECTIFIER	STATOR
FR	ALTERNATEUR	BOBINE	BOÎTIER ÉLECTRONIQUE	DÉMARREUR ÉLECTRIQUE	RÉGULATEUR	STATOR
						

PIAGGIO	Model	Year	Capacity	Part Name	Code	Code	Code	Code	Code
X8	05-06	125cc 4T LC						19588N	
X8	05-06	125cc 4T LC						37033N	
X8	05-07	200cc 4T LC						19588N	
X8	05-07	200cc 4T LC						37033N	
X8 EU3	06-08	400cc 4T LC	Piaggio M521M					16073N	
X8 PREMIUM EU2	06-06	125cc 4T LC						19588N	
X8 PREMIUM EU2	06-06	125cc 4T LC						37033N	
X8 PREMIUM EU3	06-07	125cc 4T LC						19588N	
X8 PREMIUM EU3	06-07	125cc 4T LC						37033N	
X8 STREET EU2	06-07	125cc 4T AC						19588N	
X8 STREET EU2	06-07	125cc 4T AC						37033N	
X8 STREET EU2	06-08	150cc 4T AC						19588N	
X8 STREET EU2	06-08	150cc 4T AC						37033N	
X9	01-02	125cc 4T LC						19588N	
X9	01-02	125cc 4T LC						37033N	
X9	02-03	200cc 4T LC						19588N	
X9	02-03	200cc 4T LC						37033N	
X9	01-02	500cc 4T LC						16073N	
X9 AMALFI	00-03	180cc 4T LC						19588N	
X9 AMALFI	00-03	180cc 4T LC						37033N	
X9 EVOLUTION	03-03	125cc 4T LC						19588N	
X9 EVOLUTION	03-03	125cc 4T LC						37033N	
X9 EVOLUTION	05-06	125cc 4T LC						19588N	
X9 EVOLUTION	05-06	125cc 4T LC						37033N	
X9 EVOLUTION	03-03	200cc 4T LC						19588N	
X9 EVOLUTION	03-03	200cc 4T LC						37033N	
X9 EVOLUTION	03-05	500cc 4T LC	Piaggio					16073N	
X9 EVOLUTION	06-07	500cc 4T LC	Piaggio					16073N	
X9 EVOLUTION ABS	06-07	500cc 4T LC	Piaggio					16073N	
X9 EVOLUTION EU3	07-07	125cc 4T LC						19588N	

IT	ALTERNATORE	BOBINA	CENTRALINA	MOTORINO AVVIAMENTO	REGOLATORE	STATORE
EN	ALTERNATOR	COIL	CDI	STARTER ENGINE	RECTIFIER	STATOR
FR	ALTERNATEUR	BOBINE	BOÎTIER ÉLECTRONIQUE	DÉMARREUR ÉLECTRIQUE	RÉGULATEUR	STATOR
						

PIAGGIO	Model	Year	Engine	Notes	Part No.	Part No.	Part No.	Part No.	Part No.	Part No.
PIAGGIO	X9 EVOLUTION EU3	07-07	125cc 4T LC					37033N		
	ZIP	00-02	125cc 4T AC					19588N		
	ZIP	00-02	125cc 4T AC	Leader				37033N		
	ZIP 4T	06-10	100cc 4T AC					16088N		
POLARIS	OUTLAW IRS	07-11	525cc 4T					19620N		
	OUTLAW MXR	08-10	450cc 4T					19620N		
SUZUKI	OUTLAW S	08-10	525cc 4T					19620N		
	AH ADDRESS	92-95	50cc 2T AC	Motore Suzuki				37036N		
SUZUKI	AJ ZZ	95-97	50cc 2T AC	Motore Suzuki				37036N		
	AN BURGMAN K7/LO	07-10	400cc 4T					18886N		
SUZUKI	AN BURGMAN L1	11-11	400cc 4T					18886N		
	AN BURGMAN L2	12-12	400cc 4T					18886N		
SUZUKI	AN BURGMAN L3	13-13	400cc 4T					18886N		
	AP	94-97	50cc 2T AC	Motore Suzuki				37036N		
SUZUKI	C50 BOULEVARD	05-13	800cc 4T					18787N		
	C50 BOULEVARD B.O.S.S.	14-14	800cc 4T					18787N		
SUZUKI	C50 BOULEVARD SE	09-13	800cc 4T					18787N		
	C50B BOULEVARD	05-08	800cc 4T					18787N		
SUZUKI	C50C BOULEVARD	06-08	800cc 4T					18787N		
	C50T BOULEVARD	05-13	800cc 4T					18787N		
SUZUKI	C50T BOULEVARD CLASSIC	12-12	800cc 4T					18787N		
	DR-Z400	00-04	400cc 4T					18718N		
SUZUKI	DR-Z400E	00-07	400cc 4T					18718N		
	DR-Z400S	00-15	400cc 4T					18718N		
SUZUKI	DR-Z400SM	05-15	400cc 4T					18718N		
	DR125 SE R-S	94-95	125cc 4T AC			CPS32				
SUZUKI	DR250SE	90-95	250cc 4T					18747N		
	DR350S	90-93	350cc 4T					18747N		
SUZUKI	DR350SE	94-95	350cc 4T					18747N		
	DR350SE	96-99	350cc 4T					18747N		

IT	ALTERNATORE	BOBINA	CENTRALINA	MOTORINO AVVIAMENTO	REGOLATORE	STATORE
EN	ALTERNATOR	COIL	CDI	STARTER ENGINE	RECTIFIER	STATOR
FR	ALTERNATEUR	BOBINE	BOÎTIER ÉLECTRONIQUE	DÉMARREUR ÉLECTRIQUE	RÉGULATEUR	STATOR
						

SUZUKI	Model	Year	Engine	Part	Part Number	Part Number
	GN125(E)	82-96	125cc 4T AC		CPS32	
	GS	89-02	500cc 4T			18788N
	GS-F K4-K9, L0	04-09	500cc 4T			18788N
	GSF BANDIT	91-93	400cc 4T			18743N
	GSF BANDIT S	96-96	600cc 4T			18743N
	GSF BANDIT S	96-03	600cc 4T			18743N
	GSF1200S BANDIT	97-06	1200cc 4T			18733N
	GSF1250 BANDIT K7-L0	07-10	1250cc 4T			16087N
	GSF1250 BANDIT L0	10-10	1250cc 4T			16087N
	GSF1250 BANDIT L1	11-11	1250cc 4T			16087N
	GSF1250FA L0	10-10	1250cc 4T			16087N
	GSF1250FA L1	11-11	1250cc 4T			16087N
	GSF1250S BANDIT L1	11-11	1250cc 4T			16087N
	GSX F	98-03	600cc 4T			18743N
	GSX F	98-06	600cc 4T			18743N
	GSX F	89-97	750cc 4T			18788N
	GSX F	98-06	750cc 4T			18743N
	GSX-G	91-93	1100cc 4T			18733N
	GSX-R	92-93	600cc 4T			18784N
	GSX-R	97-00	600cc 4T			18791N
	GSX-R	01-03	600cc 4T			27-7015
	GSX-R	11-17	600cc 4T			27-7033
	GSX-R	88-92	750cc 4T			18788N
	GSX-R	93-93	750cc 4T			18784N
	GSX-R	94-95	750cc 4T			18784N
	GSX-R	96-99	750cc 4T			18792N
	GSX-R	00-03	750cc 4T			27-7015
	GSX-R	11-17	750cc 4T			27-7033
	GSX-R	89-92	1100cc 4T			18733N
	GSX-R	93-98	1100cc 4T			18784N

IT	ALTERNATORE	BOBINA	CENTRALINA	MOTORINO AVVIAMENTO	REGOLATORE	STATORE
EN	ALTERNATOR	COIL	CDI	STARTER ENGINE	RECTIFIER	STATOR
FR	ALTERNATEUR	BOBINE	BOÎTIER ÉLECTRONIQUE	DÉMARREUR ÉLECTRIQUE	RÉGULATEUR	STATOR
						

SUZUKI	Model	Year	Capacity	Motor	Part Number				
	GSX-R HAYABUSA	99-03	1300cc 4T		18798N				
	GSX-R HAYABUSA	99-07	1300cc 4T		18814N				
	GSX-R HAYABUSA LIMITED EDITION	06-06	1300cc 4T		18814N				
	KATANA V-Y	97-00	50cc 2T LC	Motore Suzuki	37036N				
	LT-Z400 QUADSPORT Z	03-09	400cc 4T		18718N				
	M50 BOULEVARD	05-05	800cc 4T		18787N				
	M50 BOULEVARD	06-09	800cc 4T		18787N				
	M50 BOULEVARD	13-13	800cc 4T		18787N				
	M50 BOULEVARD LIMITED	07-07	800cc 4T		18787N				
	M50 BOULEVARD SE	09-09	800cc 4T		18787N				
	M50B BOULEVARD	05-06	800cc 4T		18787N				
	M95 BOULEVARD	05-05	1600cc 4T		18692N				
	RF	93-96	600cc 4T		18784N				
	RF	94-96	900cc 4T		18784N				
	S50 BOULEVARD	05-09	800cc 4T		18787N				
	STREET MAGIC	98-98	50cc 2T AC	Motore Suzuki	37036N				
	VL800	13-15	800cc 4T		18787N				
	VL800 INTRUDER VOLUSIA	01-05	800cc 4T		18787N				
	VS750GL INTRUDER	85-91	750cc 4T		18787N				
	VS800GL INTRUDER	92-08	800cc 4T		18787N				
	VX800	90-94	800cc 4T		18787N				
	VZ1600 MARAUDER	04-04	1600cc 4T		18692N				
	VZ800 INTRUDER	13-13	800cc 4T		18787N				
	VZ800 MARAUDER	05-08	800cc 4T		18787N				
	ZILLION UX	99-99	50cc 2T LC	Motore Suzuki	37036N				
SYM	GTS JOYMAX	06-07	125cc 4T LC		37042N				
	HD EU3	07-08	125cc 4T-4V LC		37042N				
	HD EVO	05-06	125cc 4T-4V LC		37042N				
	HD EVO EU3	07-08	125cc 4T-4V LC		37042N				
	HD EVO EU3	10-11	125cc 4T-4V LC		37042N				

IT	ALTERNATORE	BOBINA	CENTRALINA	MOTORINO AVVIAMENTO	REGOLATORE	STATORE
EN	ALTERNATOR	COIL	CDI	STARTER ENGINE	RECTIFIER	STATOR
FR	ALTERNATEUR	BOBINE	BOÎTIER ÉLECTRONIQUE	DÉMARREUR ÉLECTRIQUE	RÉGULATEUR	STATOR
						

SYM	Model	Year	Engine	Part No.	Part No.	Part No.	Part No.	Part No.	Part No.
	HD EVO TAMBURO EU3	08-09	125cc 4T-4V LC				37042N		
	HD2	11-11	125cc 4T-4V LC				37042N		
	HD2	14-14	125cc 4T-4V LC				37042N		
	JET	99-01	50cc 2T AC				37010N		
	JOYRIDE	01-02	125cc 4T-4V LC				37042N		
	JOYRIDE	01-02	125cc 4T-4V LC				37042N		
	JOYRIDE EU2	05-06	125cc 4T-4V LC				37042N		
	JOYRIDE EU3	07-07	125cc 4T-4V LC				37042N		
	JOYRIDE EVO	09-10	125cc 4T-4V LC				37042N		
	JOYRIDE EVO	10-10	125cc 4T-4V LC				37042N		
	JOYRIDE EVO	13-13	125cc 4T-4V LC				37042N		
	JOYRIDE EVO	14-14	125cc 4T-4V LC				37042N		
	JUNGLE	99-00	50cc 2T AC				37010N		
	MASK	00-01	50cc 2T AC				37010N		
	MASK EU2	03-04	50cc 2T AC				37010N		
	RED DEVIL	99-99	50cc 2T AC				37010N		
	SUPER FANCY	98-00	50cc 2T AC				37010N		
	SYMPLY II	09-10	125cc 4T AC					YM1034N	
YAMAHA	BT BULLDOG	02-04	1100cc 4T AC					YM1034N	
	BT BULLDOG	05-06	1100cc 4T AC					YM1034N	
	BW'S 4T	10-10	125cc 4T AC	YW			16090N		
	FJ	84-85	1100cc 4T				18734N		
	FJ	86-90	1200cc 4T				18734N		
	FJ	91-93	1200cc 4T				18734N		
	FZ6	04-05	600cc 4T				18763N		
	FZ6	06-06	600cc 4T				18763N		
	FZ6	07-07	600cc 4T				18763N		
	FZ6 FAZER	04-05	600cc 4T				18763N		
	FZ6 FAZER	06-06	600cc 4T				18763N		
	FZ6 FAZER	07-07	600cc 4T				18763N		

IT	ALTERNATORE	BOBINA	CENTRALINA	MOTORINO AVVIAMENTO	REGOLATORE	STATORE
EN	ALTERNATOR	COIL	CDI	STARTER ENGINE	RECTIFIER	STATOR
FR	ALTERNATEUR	BOBINE	BOÎTIER ÉLECTRONIQUE	DÉMARREUR ÉLECTRIQUE	RÉGULATEUR	STATOR
						

YAMAHA	Model	Year	Capacity	LC	Part No.	Part No.	Part No.	Part No.	Part No.
FZ6 FAZER ABS	06-06	600cc 4T					18763N		
FZ6 FAZER ABS	07-07	600cc 4T					18763N		
FZ6 FAZER S2	07-07	600cc 4T					18763N		
FZ6 FAZER S2	08-08	600cc 4T					18763N		
FZ6 FAZER S2 ABS	08-08	600cc 4T					18763N		
FZ6 NS	05-05	600cc 4T					18763N		
FZ6 NS	06-06	600cc 4T					18763N		
FZ6 S2	07-07	600cc 4T					18763N		
FZ6 S2	08-08	600cc 4T					18763N		
FZS FAZER	01-03	1000cc 4T					18764N		
FZS FAZER	04-05	1000cc 4T					18764N		
MAJESTY	05-10	400cc 4T					18843N		
MAJESTY	12-12	400cc 4T					18843N		
MORPHOUS	06-08	250cc 4T					18843N		
SZR	95-97	660cc 4T					18760N		
T-MAX 4B5	09-11	500cc 4T LC	4B5				37039N		
T-MAX 4B5	09-11	500cc 4T LC	4B5				37039N		
T-MAX 4B5 ABS	08-11	500cc 4T LC	4B5				37039N		
T-MAX 4B5 ABS	08-11	500cc 4T LC	4B5				37039N		
T-MAX 59C	12-12	530cc 4T LC	59C				37039N		
T-MAX 59C	12-12	530cc 4T LC	59C				37039N		
T-MAX 59C	13-14	530cc 4T LC	59C				37039N		
T-MAX 59C	13-14	530cc 4T LC	59C				37039N		
T-MAX 59C	15-16	530cc 4T LC	59C				37039N		
T-MAX 59C	15-16	530cc 4T LC	59C				37039N		
T-MAX 59C ABS	12-12	530cc 4T LC	59C				37039N		
T-MAX 59C ABS	12-12	530cc 4T LC	59C				37039N		
T-MAX 59C ABS	13-14	530cc 4T LC	59C				37039N		
T-MAX 59C ABS	13-14	530cc 4T LC	59C				37039N		
T-MAX 59C ABS	15-16	530cc 4T LC	59C				37039N		

IT	ALTERNATORE	BOBINA	CENTRALINA	MOTORINO AVVIAMENTO	REGOLATORE	STATORE
EN	ALTERNATOR	COIL	CDI	STARTER ENGINE	RECTIFIER	STATOR
FR	ALTERNATEUR	BOBINE	BOÎTIER ÉLECTRONIQUE	DÉMARREUR ÉLECTRIQUE	RÉGULATEUR	STATOR
						

YAMAHA	Model	Year	Engine	Part No.	IT	EN	FR
	T-MAX 59C ABS	15-16	530cc 4T LC	59C			
	T-MAX 59C SP	15-15	530cc 4T LC	59C			
	T-MAX 59C SP	15-15	530cc 4T LC	59C			
	T-MAX 59C SP ABS	15-16	530cc 4T LC	59C			
	T-MAX 59C SP ABS	15-16	530cc 4T LC	59C			
	T-MAX 5VU	08-08	500cc 4T LC	5VU			
	T-MAX 5VU	08-08	500cc 4T LC	5VU			
	T-MAX 5VU BLACK MAX	06-06	500cc 4T LC	5VU			
	T-MAX 5VU BLACK MAX	06-06	500cc 4T LC	5VU			
	T-MAX SV	11-11	500cc 4T LC	4B5			
	T-MAX SV	11-11	500cc 4T LC	4B5			
	T-MAX SV ABS	10-11	500cc 4T LC	4B5			
	T-MAX SV ABS	10-11	500cc 4T LC	4B5			
	T-MAX WHITE MAX	10-10	500cc 4T LC	4B5			
	T-MAX WHITE MAX	10-10	500cc 4T LC	4B5			
	TRICKER	05-05	250cc 4T				
	TT	86-87	225cc 4T				
	TT E	94-95	600cc 4T				
	TT E	96-01	600cc 4T				
	TT R	99-99	225cc 4T				
	TT R	99-04	225cc 4T				
	TT R	99-06	250cc 4T				
	TT RE	04-04	600cc 4T				
	TTR125E	03-07	125cc 4T				
	TTR125LE	03-07	125cc 4T				
	V-MAX	86-01	1200cc 4T				
	V-MAX	01-07	1200cc 4T				
	WR450F	03-06	450cc 4T				
	WR450F	07-07	450cc 4T LC				
	WR450F	08-08	450cc 4T LC				

IT	ALTERNATORE	BOBINA	CENTRALINA	MOTORINO AVVIAMENTO	REGOLATORE	STATORE
EN	ALTERNATOR	COIL	CDI	STARTER ENGINE	RECTIFIER	STATOR
FR	ALTERNATEUR	BOBINE	BOÎTIER ÉLECTRONIQUE	DÉMARREUR ÉLECTRIQUE	RÉGULATEUR	STATOR
						

YAMAHA	Model	Year	Engine	Part	Code	Part	Code
	WR450F	09-09	450cc 4T LC			16075N	
	WR450F	10-11	450cc 4T LC			16075N	
	WR450F	12-12	450cc 4T LC			16075N	
	WR450F	13-13	450cc 4T LC			16075N	
	WR450F	14-14	450cc 4T LC			16075N	
	X-CITY	07-07	250cc 4T LC				YM1034N
	X-CITY	08-08	250cc 4T LC				YM1034N
	X-CITY	09-12	250cc 4T LC				YM1034N
	X-CITY	13-15	250cc 4T LC				YM1034N
	X-CITY EU3	08-11	125cc 4T-4V LC	Minarelli			YM1034N
	X-MAX	07-09	250cc 4T LC				YM1034N
	X-MAX	14-16	250cc 4T LC				YM1034N
	X-MAX ABS	14-15	250cc 4T LC				YM1034N
	X-MAX BLACK	09-09	250cc 4T LC				YM1034N
	X-MAX R	06-07	125cc 4T-4V LC	Minarelli			YM1034N
	X-MAX R	08-09	125cc 4T-4V LC	Minarelli			YM1034N
	X-MAX R	14-14	125cc 4T-4V LC	Minarelli			YM1034N
	X-MAX R	14-14	125cc 4T-4V LC	Minarelli			YM1034N
	X-MAX R	15-16	125cc 4T-4V LC	Minarelli			YM1034N
	X-MAX RA ABS	14-15	125cc 4T-4V LC	Minarelli			YM1034N
	X-MAX RA ABS	16-16	125cc 4T-4V LC	Minarelli			YM1034N
	XP530-A T-MAX SX	17-17	530cc 4T LC	BX3		37039N	
	XP530-A T-MAX SX	17-17	530cc 4T LC	BX3		37039N	
	XP530-A T-MAX SX	18-18	530cc 4T LC	BX3		37039N	
	XP530-A T-MAX SX	18-18	530cc 4T LC	BX3		37039N	
	XP530-A T-MAX SX	19-19	530cc 4T LC	BX3		37039N	
	XP530-A T-MAX SX	19-19	530cc 4T LC	BX3		37039N	
	XP530D-A T-MAX DX	17-17	530cc 4T LC	BC3		37039N	
	XP530D-A T-MAX DX	17-17	530cc 4T LC	BC3		37039N	
	XP530D-A T-MAX DX	18-18	530cc 4T LC	BC3		37039N	

IT	ALTERNATORE	BOBINA	CENTRALINA	MOTORINO AVVIAMENTO	REGOLATORE	STATORE
EN	ALTERNATOR	COIL	CDI	STARTER ENGINE	RECTIFIER	STATOR
FR	ALTERNATEUR	BOBINE	BOÎTIER ÉLECTRONIQUE	DÉMARREUR ÉLECTRIQUE	RÉGULATEUR	STATOR
						

YAMAHA	Model	Year	Engine	Part No.	IT	EN	FR
	XP530D-A T-MAX DX	18-18	530cc 4T LC	BC3			
	XP530D-A T-MAX DX	19-19	530cc 4T LC	BC3			
	XP530D-A T-MAX DX	19-19	530cc 4T LC	BC3			
	XP530E-A T-MAX	17-17	530cc 4T LC	BV11			
	XP530E-A T-MAX	17-17	530cc 4T LC	BV11			
	XP530E-A T-MAX	18-18	530cc 4T LC	BV11			
	XP530E-A T-MAX	18-18	530cc 4T LC	BV11			
	XT	92-97	225cc 4T				18747N
	XT	98-99	225cc 4T				18747N
	XT	00-02	225cc 4T				18845N
	XT	08-15	250cc 4T				19639N
	XT E	90-90	600cc 4T				18760N
	XT E	91-91	600cc 4T				18760N
	XT E	92-92	600cc 4T				18760N
	XT E	93-93	600cc 4T				18760N
	XT E	94-94	600cc 4T				18760N
	XT E	95-02	600cc 4T				18760N
	XT Z TENERE	88-88	600cc 4T				18760N
	XT Z TENERE	89-89	600cc 4T				18760N
	XT Z TENERE	90-90	600cc 4T				18760N
	XT Z TENERE	91-91	660cc 4T				18760N
	XT Z TENERE	92-92	660cc 4T				18760N
	XT Z TENERE	93-93	660cc 4T				18760N
	XT Z TENERE	94-96	660cc 4T				18760N
	XT Z TENERE	08-09	660cc 4T				18760N
	XT Z TENERE	10-12	660cc 4T				18760N
	XT Z TENERE	13-15	660cc 4T				18760N
	XT ZA TENERE	11-11	660cc 4T				18760N
	XT ZA TENERE	15-15	660cc 4T				18760N
	XT-R	04-05	660cc 4T				18760N

IT	ALTERNATORE	BOBINA	CENTRALINA	MOTORINO AVVIAMENTO	REGOLATORE	STATORE
EN	ALTERNATOR	COIL	CDI	STARTER ENGINE	RECTIFIER	STATOR
FR	ALTERNATEUR	BOBINE	BOÎTIER ÉLECTRONIQUE	DÉMARREUR ÉLECTRIQUE	RÉGULATEUR	STATOR
						

YAMAHA	Model	Year	Capacity	Part No.	Part No.	Part No.	Part No.	Part No.	Part No.
	XT-R	07-07	660cc 4T				18760N		
	XT-R	07-07	660cc 4T				18760N		
	XT-R	08-11	660cc 4T				18760N		
	XT-R	14-14	660cc 4T				18760N		
	XT-X	04-05	660cc 4T				18760N		
	XT-X	07-07	660cc 4T				18760N		
	XT-X	07-07	660cc 4T				18760N		
	XT-X	08-11	660cc 4T				18760N		
	XT-X	14-14	660cc 4T				18760N		
	XV A WILD STAR	99-02	1600cc 4T AC					YM1034N	
	XV ROUTE 66	88-90	250cc 4T				18768N		
	XV V STAR 250	08-15	250cc 4T				18768N		
	XV VIRAGO	95-07	250cc 4T				18768N		
	XV VIRAGO	84-87	700cc 4T				18727N		
	XV VIRAGO	86-87	700cc 4T				18737N		
	XV VIRAGO	81-97	750cc 4T				18727N		
	XV VIRAGO	90-97	750cc 4T				18737N		
	XV VIRAGO	82-82	920cc 4T				18727N		
	XV VIRAGO	84-85	1000cc 4T				18737N		
	XV VIRAGO	86-89	1100cc 4T				18737N		
	XV VIRAGO	90-98	1100cc 4T				18737N		
	XV VIRAGO	99-99	1100cc 4T				18748N		
	XV1600A ROAD STAR	99-03	1600cc 4T				18746N		
	XV1600A ROAD STAR	03-03	1600cc 4T				18767N		
	XV1600AS ROAD STAR MIDNIGHT	00-00	1600cc 4T				18746N		
	XV1600AS ROAD STAR MIDNIGHT	01-03	1600cc 4T				18767N		
	XV1600AT ROAD STAR SILVERADO	99-03	1600cc 4T				18746N		
	XV1700A ROAD STAR	04-07	1700cc 4T				18767N		
	XV1700AM ROAD STAR MIDNIGHT	04-07	1700cc 4T				18767N		
	XV1700AT ROAD STAR SILVERADO	04-05	1700cc 4T				18767N		

IT	ALTERNATORE	BOBINA	CENTRALINA	MOTORINO AVVIAMENTO	REGOLATORE	STATORE
EN	ALTERNATOR	COIL	CDI	STARTER ENGINE	RECTIFIER	STATOR
FR	ALTERNATEUR	BOBINE	BOÎTIER ÉLECTRONIQUE	DÉMARREUR ÉLECTRIQUE	RÉGULATEUR	STATOR
						

YAMAHA	Model	Year	Capacity	Part No.	Part No.	Part No.	Part No.	Part No.	Part No.
	XV1700AT ROAD STAR SILVERADO	06-07	1700cc 4T				18746N		
	XV1700ATM ROAD STAR MIDNIGHT SILVERADO	04-07	1700cc 4T				18767N		
	XV920M MID-VIRAGO	83-83	920cc 4T				18727N		
	XV920R SECA	81-81	920cc 4T				18727N		
	XVS A DRAG STAR CLASSIC	98-01	650cc 4T AC					YM1034N	
	XVS A DRAG STAR CLASSIC	00-02	1100cc 4T AC					YM1034N	
	XVS DRAG STAR	04-04	125cc 4T AC					YM1034N	
	XVS DRAG STAR	01-03	250cc 4T AC					YM1034N	
	XVS DRAG STAR	97-99	650cc 4T AC					YM1034N	
	XVS DRAG STAR	00-02	650cc 4T AC					YM1034N	
	XVS DRAG STAR	99-00	1100cc 4T AC					YM1034N	
	XVS DRAG STAR	01-02	1100cc 4T AC					YM1034N	
	XVS1100 V STAR 1100 CUSTOM	99-02	1100cc 4T				18748N		
	XVS1100 V STAR 1100 CUSTOM	03-09	1100cc 4T				18748N		
	XVS1100A V STAR 1100 CLASSIC	00-03	1100cc 4T				18748N		
	XVS1100A V STAR 1100 CLASSIC	03-09	1100cc 4T				18748N		
	XVS1100AT V STAR 1100 SILVERADO	02-02	1100cc 4T				18748N		
	XVS1100AT V STAR 1100 SILVERADO	03-09	1100cc 4T				18748N		
	XVZ1300A ROYAL STAR	96-98	1300cc 4T				18769N		
	XVZ1300AL ROYAL STAR BOULEVARD	99-01	1300cc 4T				18769N		
	XVZ1300AT ROYAL STAR TOUR CLASSIC	96-00	1300cc 4T				18769N		
	XVZ1300CT ROYAL STAR TOUR DELUXE	97-10	1300cc 4T				18769N		
	XVZ1300CTM ROYAL STAR MIDNIGHT TOUR DELUXE	06-07	1300cc 4T				18769N		
	XVZ1300CTS ROYAL STAR TOUR DELUXE S	08-09	1300cc 4T				18769N		
	XVZ1300TF ROYAL STAR VENTURE	99-09	1300cc 4T				18769N		
	XVZ1300TFM ROYAL STAR MIDNIGHT VENTURE	02-07	1300cc 4T				18769N		
	XVZ1300TFS ROYAL STAR VENTURE S	09-13	1300cc 4T				18769N		
	YBR	05-12	125cc 4T				19587N		
	YFM 25R	09-09	250cc 4T				19639N		
	YFM 25R	10-13	250cc 4T				19639N		
	YFM 25RX	08-08	250cc 4T				19639N		
	YFM 25RX SP	08-08	250cc 4T				19639N		
	YFM 660FA GRIZZLY 4WD	05-06	660cc 4T					YM1034N	

IT	ALTERNATORE	BOBINA	CENTRALINA	MOTORINO AVVIAMENTO	REGOLATORE	STATORE
EN	ALTERNATOR	COIL	CDI	STARTER ENGINE	RECTIFIER	STATOR
FR	ALTERNATEUR	BOBINE	BOÎTIER ÉLECTRONIQUE	DÉMARREUR ÉLECTRIQUE	RÉGULATEUR	STATOR
						

YAMAHA	Model	Year	Capacity	Code	Part No.	Part No.
	YFM 660FR GRIZZLY 4WD	03-03	660cc 4T			YM1034N
	YFM 660FW GRIZZLY 4WD	02-02	660cc 4T			YM1034N
	YFM 70RY	09-09	700cc 4T			YM1034N
	YFM 70RY SE	09-09	700cc 4T			YM1034N
	YFM 7RZ	10-12	700cc 4T			YM1034N
	YFM FS GRIZZLY 4WD	04-04	660cc 4T			YM1034N
	YFM FS GRIZZLY 4WD	05-05	660cc 4T			YM1034N
	YFM R RAPTOR	02-05	660cc 4T		18760N	
	YFM RW	07-07	700cc 4T			YM1034N
	YFM700 R	08-08	700cc 4T			YM1034N
	YFM700 R	13-14	700cc 4T			YM1034N
	YFZ R	09-12	450cc 4T		19200N	
	YFZ R	13-13	450cc 4T		19200N	
	YFZ R	14-14	450cc 4T		19200N	
	YFZ S	04-04	450cc 4T		18761N	
	YFZ SV	08-08	450cc 4T		18761N	
	YFZ450R	19-19	450cc 4T		19200N	YM1034N
	YJ RA VINO CLASSIC	02-05	50cc 4T		18749N	
	YJ VINO	01-04	50cc 4T		18749N	
	YW ZUMA	09-10	125cc 4T	YW	16090N	
	YW ZUMA	11-15	125cc 4T	YW	16090N	
	YXR RHINO	05-06	660cc 4T			YM1034N
	YXR RHINO	07-07	660cc 4T			YM1034N
	YZF R	09-12	450cc 4T		18761N	YM1034N
	YZF R	13-13	450cc 4T		18761N	YM1034N
	YZF R	14-14	450cc 4T		18761N	YM1034N
	YZF R1	98-99	1000cc 4T		18764N	
	YZF R46	05-05	600cc 4T		18763N	
	YZF R6	99-00	600cc 4T		18763N	
	YZF R6	01-02	600cc 4T		18763N	
	YZF R6	03-04	600cc 4T		18763N	
	YZF R6	05-05	600cc 4T		18763N	
	YZF-R6	99-02	600cc 4T			27-7016

**MICROCAR****MOTORPARTS**

AIXAM	AIXAM	AIXAM	AIXAM
300	300	400	400
96-04	99-05	96-04	99-05
276cc	276cc	400cc	400cc

IT	EN	FR				
AMMORTIZZATORI ANTERIORI	FRONT SHOCK ABSORBERS	AMORTISSEURS AVANT		SAM0001		SAM0001
AMMORTIZZATORI POSTERIORI	REAR SHOCK ABSORBERS	AMORTISSEURS ARRIERE				SAM0002
CILINDRETTI FRENO	JOINTS	JOINTS				
DISCHI FRENO ANTERIORI	FRONT BRAKE DISCS	DISQUES DE FREIN AVANT				
DISCHI FRENO POSTERIORI	REAR BRAKE DISCS	DISQUES DE FREINS ARRIERE				
DISCHI FRENO POSTERIORI VENTILATI	REAR VENTED BRAKE DISCS	DISQUES DE FREIN ARRIERE VENTILES				
FILTRI ARIA	AIR FILTERS	FILTRES À AIR				
FILTRI CARBURANTE	GASOLINE FILTERS	FILTRES À ESSENCE				
FILTRI GASOLIO	DIESEL FILTERS	FILTRES DIESEL				
FILTRI OLIO	OIL FILTERS	FILTRES À HUILE				
GIUNTI	JOINTS	JOINTS			HJM1015K	HJM1015K
KIT CUSCINETTI RUOTA	WHEEL BEARINGS	ROULEMENTS DE ROUE				
KIT DISTRIBUZIONE MOTORE	TIMING BELT KIT	KIT DE COURROIE DE DISTRIBUTION				
PASTIGLIE FRENO ANTERIORE	FRONT BRAKE PADS	PLAQUETTES DE FREIN AVANT				
PASTIGLIE FRENO POSTERIORE	REAR BRAKE PADS	PLAQUETTES DE FREIN ARRIERE				
PINZE FRENO ANTERIORI	FRONT BRAKE CALLIPERS	ETRIERS DE FREINS AVANT				
PINZE FRENO POSTERIORI	REAR BRAKE CALLIPERS	ETRIERS DE FREINS ARRIERE				
SEMIASSI	HALF SHAFTS	DEMI-ESSIEUX			DSM03265	DSM03166 DSM03264 DSM03265
TENDICINGHIA DISTRIBUZIONE	TIMING BELT TENSIONER	TENDEUR DE COURROIE DE DISTRIBUTION				
TESTE STERZO	STEERING BEARINGS	ROULEMENTS DE DIRECTION				

AIXAM	AIXAM	AIXAM	AIXAM	AIXAM	AIXAM	AIXAM	AIXAM	AIXAM	AIXAM	AIXAM	AIXAM
500	500,4	500,4	A721	A721	A741	A741	A751	CITY	CITY	CITY ABS	CITY ABS
99-05	97-05	99-05	05-08	05-08	05-08	05-08	05-08	10-12	12-19	10-12	12-19
400cc	400cc	400cc	400cc	400cc	400cc	400cc	500cc	400cc	500cc	400cc	500cc
	SAM0001			SAM0001		SAM0001					
HJM1015K		HJM1015K	HJM1015K		HJM1015K		HJM1015K	HJM1019K	HJM1019K	HJM1018K	HJM1018K
DSM03265		DSM03166	DSM03165		DSM03165		DSM03165	DSM03298	DSM03161	DSM03151	DSM03162 DSM03163

**MICROCAR****MOTORPARTS**

AIXAM	AIXAM	AIXAM	AIXAM
COUPÈ	CROSSLINE	CROSSLINE	CROSSLINE ABS
12-19	10-19	10-19	10-19
500cc	400cc	500cc	400cc

IT	EN	FR					
AMMORTIZZATORI ANTERIORI	FRONT SHOCK ABSORBERS	AMORTISSEURS AVANT					
AMMORTIZZATORI POSTERIORI	REAR SHOCK ABSORBERS	AMORTISSEURS ARRIERE					
CILINDRETTI FRENO	JOINTS	JOINTS					
DISCHI FRENO ANTERIORI	FRONT BRAKE DISCS	DISQUES DE FREIN AVANT					
DISCHI FRENO POSTERIORI	REAR BRAKE DISCS	DISQUES DE FREINS ARRIERE					
DISCHI FRENO POSTERIORI VENTILATI	REAR VENTED BRAKE DISCS	DISQUES DE FREIN ARRIERE VENTILES					
FILTRI ARIA	AIR FILTERS	FILTRES À AIR					
FILTRI CARBURANTE	GASOLINE FILTERS	FILTRES À ESSENCE					
FILTRI GASOLIO	DIESEL FILTERS	FILTRES DIESEL					
FILTRI OLIO	OIL FILTERS	FILTRES À HUILE					
GIUNTI	JOINTS	JOINTS		HJM1019K	HJM1019K	HJM1019K	HJM1018K
KIT CUSCINETTI RUOTA	WHEEL BEARINGS	ROULEMENTS DE ROUE					
KIT DISTRIBUZIONE MOTORE	TIMING BELT KIT	KIT DE COURROIE DE DISTRIBUTION					
PASTIGLIE FRENO ANTERIORE	FRONT BRAKE PADS	PLAQUETTES DE FREIN AVANT					
PASTIGLIE FRENO POSTERIORE	REAR BRAKE PADS	PLAQUETTES DE FREIN ARRIERE					
PINZE FRENO ANTERIORI	FRONT BRAKE CALLIPERS	ETRIERS DE FREINS AVANT					
PINZE FRENO POSTERIORI	REAR BRAKE CALLIPERS	ETRIERS DE FREINS ARRIERE					
SEMIASSI	HALF SHAFTS	DEMI-ESSIEUX		DSM03161	DSM03298	DSM03298	DSM03151
TENDICINGHIA DISTRIBUZIONE	TIMING BELT TENSIONER	TENDEUR DE COURROIE DE DISTRIBUTION					
TESTE STERZO	STEERING BEARINGS	ROULEMENTS DE DIRECTION					

AIXAM	AIXAM	AIXAM	AIXAM	AIXAM	AIXAM	BELLIER	BELLIER	BELLIER	BELLIER	BELLIER	BELLIER
CROSSLINE ABS	D-TRUCK	EVOLUTION 400	GTO	GTO ABS	MULTI TRUCK	B8	B8	B8	B8	B8	B8
10-19	12-19	02-19	10-19	10-19	12-19	15-16	16-17	17-19	15-16	16-17	17-19
500cc	478cc	400cc	400cc	400cc	478cc	440cc	440cc	440cc	523cc	523cc	523cc
	SAM0027				SAM0029						
	SAM0028				SAM0030						
HJM1018K		HJM1015K	HJM1019K	HJM1018K		HJM1014K	HJM1014K	HJM1014K	HJM1014K	HJM1014K	HJM1014K
DSM03151		DSM03166	DSM03298	DSM03151		DSM03295	DSM03002 DSM03003	DSM03280	DSM03295	DSM03002 DSM03003	DSM03280

**MICROCAR****MOTORPARTS**

BELLIER	BELLIER	CASALINI	CASALINI
DOCKER	JADE	KERRY	KERRY
16-19	16-19	15-19	15-19
480cc	523cc	538cc	635cc

IT	EN	FR				
AMMORTIZZATORI ANTERIORI	FRONT SHOCK ABSORBERS	AMORTISSEURS AVANT				
AMMORTIZZATORI POSTERIORI	REAR SHOCK ABSORBERS	AMORTISSEURS ARRIERE				
CILINDRETTI FRENO	JOINTS	JOINTS				
DISCHI FRENO ANTERIORI	FRONT BRAKE DISCS	DISQUES DE FREIN AVANT				
DISCHI FRENO POSTERIORI	REAR BRAKE DISCS	DISQUES DE FREINS ARRIERE				
DISCHI FRENO POSTERIORI VENTILATI	REAR VENTED BRAKE DISCS	DISQUES DE FREIN ARRIERE VENTILES				
FILTRI ARIA	AIR FILTERS	FILTRES À AIR				
FILTRI CARBURANTE	GASOLINE FILTERS	FILTRES À ESSENCE				
FILTRI GASOLIO	DIESEL FILTERS	FILTRES DIESEL				
FILTRI OLIO	OIL FILTERS	FILTRES À HUILE				
GIUNTI	JOINTS	JOINTS		HJM1014K	HJM1014K	HJM1014K
KIT CUSCINETTI RUOTA	WHEEL BEARINGS	ROULEMENTS DE ROUE				
KIT DISTRIBUZIONE MOTORE	TIMING BELT KIT	KIT DE COURROIE DE DISTRIBUTION				
PASTIGLIE FRENO ANTERIORE	FRONT BRAKE PADS	PLAQUETTES DE FREIN AVANT				
PASTIGLIE FRENO POSTERIORE	REAR BRAKE PADS	PLAQUETTES DE FREIN ARRIERE				
PINZE FRENO ANTERIORI	FRONT BRAKE CALLIPERS	ETRIERS DE FREINS AVANT				
PINZE FRENO POSTERIORI	REAR BRAKE CALLIPERS	ETRIERS DE FREINS ARRIERE				
SEMIASSI	HALF SHAFTS	DEMI-ESSIEUX		DSM03279	DSM03176 DSM03075	DSM03235 DSM03236
TENDICINGHIA DISTRIBUZIONE	TIMING BELT TENSIONER	TENDEUR DE COURROIE DE DISTRIBUTION				
TESTE STERZO	STEERING BEARINGS	ROULEMENTS DE DIRECTION				

CASALINI	CASALINI	CASALINI	CASALINI	CASALINI	CASALINI	CHATENET	CHATENET	CHATENET	CHATENET	CHATENET	CHATENET
M12 PICKUP	M14	M14	M14 ABS	M20	YDEA	BAROODER	BAROODER	CH26	CH26	CH26 EVO	CH26 I
15-19	08-12	12-14	14-19	17-19	00-00	08-19	08-19	10-19	10-19	16-19	10-10
635cc	538cc	538cc	635cc	480cc	500cc	505cc	505cc	505cc	505cc	505cc	505cc
					SAM0008		SAM0004		SAM0020		
					SAM0009		SAM0035		SAM0038		SAM0040
								BDM0005		BDM0005	
								BDM0006 BDM0007		BDM0006 BDM0007	
HJM1014K	HJM1014K	HJM1014K	HJM1017K	HJM1014K		HJM1014K				HJM1014K HJM1020K	
								BPM0003		BPM0003	
								BPM0004		BPM0004	
								BCM6009 BCM6010		BCM6009 BCM6010	
								BCM6011 BCM6012		BCM6011 BCM6012	
DSM03235 DSM03236	DSM03184 DSM03185	DSM03153 DSM03154 DSM03156	DSM03268 DSM03269	DSM03275 DSM03276		DSM03184 DSM03180				DSM03271 DSM03134	

**MICROCAR****MOTORPARTS**

CHATENET	CHATENET	CHATENET	CHATENET
CH26 MEDIA	CJF 214	MEDIA	MEDIA
10-10	95-01	98-01	98-01
505cc	505cc	505cc	505cc

IT	EN	FR					
AMMORTIZZATORI ANTERIORI	FRONT SHOCK ABSORBERS	AMORTISSEURS AVANT					SAM0005
AMMORTIZZATORI POSTERIORI	REAR SHOCK ABSORBERS	AMORTISSEURS ARRIERE		SAM0039			
CILINDRETTI FRENO	JOINTS	JOINTS					
DISCHI FRENO ANTERIORI	FRONT BRAKE DISCS	DISQUES DE FREIN AVANT					
DISCHI FRENO POSTERIORI	REAR BRAKE DISCS	DISQUES DE FREINS ARRIERE					
DISCHI FRENO POSTERIORI VENTILATI	REAR VENTED BRAKE DISCS	DISQUES DE FREIN ARRIERE VENTILES					
FILTRI ARIA	AIR FILTERS	FILTRES À AIR					
FILTRI CARBURANTE	GASOLINE FILTERS	FILTRES À ESSENCE					
FILTRI GASOLIO	DIESEL FILTERS	FILTRES DIESEL					
FILTRI OLIO	OIL FILTERS	FILTRES À HUILE					
GIUNTI	JOINTS	JOINTS			HJM1014K	HJM1014K	
KIT CUSCINETTI RUOTA	WHEEL BEARINGS	ROULEMENTS DE ROUE					
KIT DISTRIBUZIONE MOTORE	TIMING BELT KIT	KIT DE COURROIE DE DISTRIBUTION					
PASTIGLIE FRENO ANTERIORE	FRONT BRAKE PADS	PLAQUETTES DE FREIN AVANT					
PASTIGLIE FRENO POSTERIORE	REAR BRAKE PADS	PLAQUETTES DE FREIN ARRIERE					
PINZE FRENO ANTERIORI	FRONT BRAKE CALLIPERS	ETRIERS DE FREINS AVANT					
PINZE FRENO POSTERIORI	REAR BRAKE CALLIPERS	ETRIERS DE FREINS ARRIERE					
SEMIASSI	HALF SHAFTS	DEMI-ESSIEUX			DSM03235	DSM03235	
TENDICINGHIA DISTRIBUZIONE	TIMING BELT TENSIONER	TENDEUR DE COURROIE DE DISTRIBUTION					
TESTE STERZO	STEERING BEARINGS	ROULEMENTS DE DIRECTION					

CHATENET	GREKAV	ITALCAR	ITALCAR	JDM	JDM	JDM	JDM	JDM	JDM	JDM	JDM
STELLA	EKE	T2	T3	ABACA	ABACA	ABACA	ABACA MOUNTAIN	ALBIZIA	ALBIZIA	ALOES	ROXSY
00-04	00-10	06-07	06-07	05-19	05-19	05-19	07-10	02-07	02-07	08-19	08-19
505cc	505cc	505cc	505cc	505cc	505cc	523cc	523cc	505cc	523cc	523cc	440cc
	SAM0011	SAM0019	SAM0019		SAM0007		SAM0006				
											BDM0005
											BDM0006 BDM0007
HJM1014K				HJM1014K		HJM1014K		HJM1014K	HJM1014K	HJM1014K	HJM1014K
											BPM0003
											BPM0004
											BCM6009 BCM6010
											BCM6011 BCM6012
DSM03235				DSM03235 DSM03048		DSM03235 DSM03048		DSM03235 DSM03048	DSM03235 DSM03048	DSM03184	DSM03184

JDM	JDM	JDM	JDM
ROXSY	SIMPA	TITANE	TITANE 1/2/3
08-19	02-19	99-02	99-02
523cc	440cc	523cc	523cc

IT	EN	FR				
AMMORTIZZATORI ANTERIORI	FRONT SHOCK ABSORBERS	AMORTISSEURS AVANT				SAM0010
AMMORTIZZATORI POSTERIORI	REAR SHOCK ABSORBERS	AMORTISSEURS ARRIERE				
CILINDRETTI FRENO	JOINTS	JOINTS				
DISCHI FRENO ANTERIORI	FRONT BRAKE DISCS	DISQUES DE FREIN AVANT		BDM0005		
DISCHI FRENO POSTERIORI	REAR BRAKE DISCS	DISQUES DE FREINS ARRIERE		BDM0006 BDM0007		
DISCHI FRENO POSTERIORI VENTILATI	REAR VENTED BRAKE DISCS	DISQUES DE FREIN ARRIERE VENTILES				
FILTRI ARIA	AIR FILTERS	FILTRES À AIR				
FILTRI CARBURANTE	GASOLINE FILTERS	FILTRES À ESSENCE				
FILTRI GASOLIO	DIESEL FILTERS	FILTRES DIESEL				
FILTRI OLIO	OIL FILTERS	FILTRES À HUILE				
GIUNTI	JOINTS	JOINTS		HJM1014K	HJM1014K	HJM1014K
KIT CUSCINETTI RUOTA	WHEEL BEARINGS	ROULEMENTS DE ROUE				
KIT DISTRIBUZIONE MOTORE	TIMING BELT KIT	KIT DE COURROIE DE DISTRIBUTION				
PASTIGLIE FRENO ANTERIORE	FRONT BRAKE PADS	PLAQUETTES DE FREIN AVANT		BPM0003		
PASTIGLIE FRENO POSTERIORE	REAR BRAKE PADS	PLAQUETTES DE FREIN ARRIERE		BPM0004		
PINZE FRENO ANTERIORI	FRONT BRAKE CALLIPERS	ETRIERS DE FREINS AVANT		BCM6009 BCM6010		
PINZE FRENO POSTERIORI	REAR BRAKE CALLIPERS	ETRIERS DE FREINS ARRIERE		BCM6011 BCM6012		
SEMIASSI	HALF SHAFTS	DEMI-ESSIEUX		DSM03184	DSM03026 DSM03027	DSM03176
TENDICINGHIA DISTRIBUZIONE	TIMING BELT TENSIONER	TENDEUR DE COURROIE DE DISTRIBUTION				
TESTE STERZO	STEERING BEARINGS	ROULEMENTS DE DIRECTION				

JDM	LIGIER	LIGIER	LIGIER	LIGIER	LIGIER	LIGIER	LIGIER	LIGIER	LIGIER	LIGIER	LIGIER
XHE0S	AMBRA 162	IX0	JS 20	JS 36	JS 40	JS 48 (P70)	JS 50 C	JS 50 F1	JS 50 F1	JS 50 F1	JS 50 F1
08-19	98-00	11-19	10-10	14-19	11-19	09-19	00-05	09-10	09-10	10-12	10-12
442cc	500cc DIESEL	505cc	505cc	505cc	505cc	505cc	505cc	505cc	505cc	505cc	505cc
			SAM0032				SAM0021		SAM0015		SAM0015
									SAM0016		SAM0016
BDM0005		BDM0001		BDM0001	BDM0001						
BDM0006 BDM0007		BDM0004		BDM0004	BDM0004						
		BDM0002 BDM0003		BDM0002 BDM0003	BDM0002 BDM0003						
HJM1014K		HJM1015K		HJM1015K	HJM1015K	HJM1015K		HJM1015K		HJM1015K	
BPM0003		BPM0001		BPM0001	BPM0001						
BPM0004		BPM0002		BPM0002	BPM0002						
BCM6009 BCM6010		BCM6001 BCM6002		BCM6001 BCM6002	BCM6001 BCM6002						
BCM6011 BCM6012		BCM6003 BCM6004		BCM6003 BCM6004	BCM6003 BCM6004						
DSM03184		DSM03165 DSM03166		DSM03263	DSM03220 DSM03234	DSM03150		DSM03129 DSM03130		DSM03272	
	TDM0001										

**MICROCAR****MOTORPARTS****LIGIER** **LIGIER** **LIGIER** **LIGIER**

JS 50 F1 JS 50 F2/F3 JS 50 F4 JS RC

10-12 12-19 19-19 08-19

505cc 505cc 505cc 505cc

IT	EN	FR				
AMMORTIZZATORI ANTERIORI	FRONT SHOCK ABSORBERS	AMORTISSEURS AVANT		SAM0015		
AMMORTIZZATORI POSTERIORI	REAR SHOCK ABSORBERS	AMORTISSEURS ARRIERE		SAM0016		
CILINDRETTI FRENO	JOINTS	JOINTS				
DISCHI FRENO ANTERIORI	FRONT BRAKE DISCS	DISQUES DE FREIN AVANT				BDM0001
DISCHI FRENO POSTERIORI	REAR BRAKE DISCS	DISQUES DE FREINS ARRIERE				BDM0004
DISCHI FRENO POSTERIORI VENTILATI	REAR VENTED BRAKE DISCS	DISQUES DE FREIN ARRIERE VENTILES				BDM0002 BDM0003
FILTRI ARIA	AIR FILTERS	FILTRES À AIR				
FILTRI CARBURANTE	GASOLINE FILTERS	FILTRES À ESSENCE				
FILTRI GASOLIO	DIESEL FILTERS	FILTRES DIESEL				
FILTRI OLIO	OIL FILTERS	FILTRES À HUILE				
GIUNTI	JOINTS	JOINTS			HJM1015K	HJM1015K HJM1014K
KIT CUSCINETTI RUOTA	WHEEL BEARINGS	ROULEMENTS DE ROUE				
KIT DISTRIBUZIONE MOTORE	TIMING BELT KIT	KIT DE COURROIE DE DISTRIBUTION				
PASTIGLIE FRENO ANTERIORE	FRONT BRAKE PADS	PLAQUETTES DE FREIN AVANT				BPM0001
PASTIGLIE FRENO POSTERIORE	REAR BRAKE PADS	PLAQUETTES DE FREIN ARRIERE				BPM0002
PINZE FRENO ANTERIORI	FRONT BRAKE CALLIPERS	ETRIERS DE FREINS AVANT				BCM6001 BCM6002
PINZE FRENO POSTERIORI	REAR BRAKE CALLIPERS	ETRIERS DE FREINS ARRIERE				BCM6003 BCM6004
SEMIASSI	HALF SHAFTS	DEMI-ESSIEUX			DSM03157 DSM03158	DSM03296 DSM03184
TENDICINGHIA DISTRIBUZIONE	TIMING BELT TENSIONER	TENDEUR DE COURROIE DE DISTRIBUTION				
TESTE STERZO	STEERING BEARINGS	ROULEMENTS DE DIRECTION				

LIGIER	LIGIER	LIGIER	LIGIER	LIGIER	LIGIER	LIGIER	LIGIER	LIGIER	LIGIER	LIGIER	LIGIER
NOVA	NOVA	OPTIMAX	PRIMA	X-T00	X-T00	X-T00	X-T00	X-T00 MAX	X-T00 MAX	X-T00 R	X-T00 R
00-00	99-04	00-19	00-19	02-05	02-05	05-07	07-19	02-05	02-05	00-19	00-19
500cc DIESEL	505cc	505cc	505cc	505cc	505cc	505cc	505cc	505cc	505cc	505cc	505cc
	SAM0003				SAM0003				SAM0026		SAM0013
	SAM0012								SAM0014		SAM0014
		BDM0001									
		BDM0004									
		BDM0002 BDM0003									
		HJM1014K	HJM1014K	HJM1014K		HJM1014K	HJM1014K	HJM1014K		HJM1014K	
		BPM0001									
		BPM0002									
		BCM6001 BCM6002									
		BCM6003 BCM6004									
		DSM03180	DSM03180	DSM03176		DSM03066	DSM03091 DSM03092	DSM03176		DSM03180	
TDM0001											

MICROCAR	MICROCAR	MICROCAR	MICROCAR
CARGO	DUÈ	DUÈ F1RST	F8
07-19	14-14	11-19	11-19
505cc	505cc	505cc	505cc

IT	EN	FR				
AMMORTIZZATORI ANTERIORI	FRONT SHOCK ABSORBERS	AMORTISSEURS AVANT			SAM0022	
AMMORTIZZATORI POSTERIORI	REAR SHOCK ABSORBERS	AMORTISSEURS ARRIERE			SAM0023	
CILINDRETTI FRENO	JOINTS	JOINTS				
DISCHI FRENO ANTERIORI	FRONT BRAKE DISCS	DISQUES DE FREIN AVANT		BDM0001		BDM0001
DISCHI FRENO POSTERIORI	REAR BRAKE DISCS	DISQUES DE FREINS ARRIERE		BDM0004		BDM0004
DISCHI FRENO POSTERIORI VENTILATI	REAR VENTED BRAKE DISCS	DISQUES DE FREIN ARRIERE VENTILES		BDM0002 BDM0003		BDM0002 BDM0003
FILTRI ARIA	AIR FILTERS	FILTRES À AIR				
FILTRI CARBURANTE	GASOLINE FILTERS	FILTRES À ESSENCE				
FILTRI GASOLIO	DIESEL FILTERS	FILTRES DIESEL				
FILTRI OLIO	OIL FILTERS	FILTRES À HUILE				
GIUNTI	JOINTS	JOINTS		HJM1014K		
KIT CUSCINETTI RUOTA	WHEEL BEARINGS	ROULEMENTS DE ROUE				
KIT DISTRIBUZIONE MOTORE	TIMING BELT KIT	KIT DE COURROIE DE DISTRIBUTION				
PASTIGLIE FRENO ANTERIORE	FRONT BRAKE PADS	PLAQUETTES DE FREIN AVANT		BPM0001		BPM0001
PASTIGLIE FRENO POSTERIORE	REAR BRAKE PADS	PLAQUETTES DE FREIN ARRIERE		BPM0002		BPM0002
PINZE FRENO ANTERIORI	FRONT BRAKE CALLIPERS	ETRIERS DE FREINS AVANT		BCM6001 BCM6002		BCM6001 BCM6002
PINZE FRENO POSTERIORI	REAR BRAKE CALLIPERS	ETRIERS DE FREINS ARRIERE		BCM6003 BCM6004		BCM6003 BCM6004
SEMIASSI	HALF SHAFTS	DEMI-ESSIEUX		DSM03180		
TENDICINGHIA DISTRIBUZIONE	TIMING BELT TENSIONER	TENDEUR DE COURROIE DE DISTRIBUTION				
TESTE STERZO	STEERING BEARINGS	ROULEMENTS DE DIRECTION				

MICROCAR	MICROCAR	MICROCAR	MICROCAR	MICROCAR	MICROCAR	MICROCAR	MICROCAR	MICROCAR	MICROCAR	MICROCAR	MICROCAR
M8	M8	MC1	MC1	MC2	MGO 1	MGO 1	MGO 2	MGO 2	MGO 3	MGO 4	MGO 4
16-19	16-19	03-07	03-07	03-07	08-13	13-15	08-13	13-15	15-19	16-19	16-19
480cc	500cc	505cc	523cc	505cc	505cc	505cc	505cc	505cc	505cc	498cc	505cc
BDM0001	BDM0001							BDM0001			
BDM0004	BDM0004							BDM0004			
BDM0002 BDM0003	BDM0002 BDM0003							BDM0002 BDM0003			
		HJM1015K	HJM1015K	HJM1015K	HJM1014K	HJM1005K	HJM1014K	HJM1005K	HJM1014K HJM1005K	HJM1014K	HJM1014K
BPM0001	BPM0001							BPM0001			
BPM0002	BPM0002							BPM0002			
BCM6001 BCM6002	BCM6001 BCM6002							BCM6001 BCM6002			
BCM6003 BCM6004	BCM6003 BCM6004							BCM6003 BCM6004			
		DSM03165 DSM03166	DSM03165 DSM03166	DSM03165 DSM03166	DSM03184	DSM03097	DSM03184	DSM03097	DSM03180 DSM03086	DSM03180	DSM03180

MICROCAR	PIAGGIO	PIAGGIO	PIAGGIO
VIRGO II	AL DIESEL	M 500	PK 500
02-04	04-07	03-10	03-10
505cc	500cc DIESEL	500cc DIESEL	500cc DIESEL

IT	EN	FR				
AMMORTIZZATORI ANTERIORI	FRONT SHOCK ABSORBERS	AMORTISSEURS AVANT		SAM0017		
AMMORTIZZATORI POSTERIORI	REAR SHOCK ABSORBERS	AMORTISSEURS ARRIERE		SAM0018		
CILINDRETTI FRENO	JOINTS	JOINTS				
DISCHI FRENO ANTERIORI	FRONT BRAKE DISCS	DISQUES DE FREIN AVANT				
DISCHI FRENO POSTERIORI	REAR BRAKE DISCS	DISQUES DE FREINS ARRIERE				
DISCHI FRENO POSTERIORI VENTILATI	REAR VENTED BRAKE DISCS	DISQUES DE FREIN ARRIERE VENTILES				
FILTRI ARIA	AIR FILTERS	FILTRES À AIR				FAMC011
FILTRI CARBURANTE	GASOLINE FILTERS	FILTRES À ESSENCE				FCMC002
FILTRI GASOLIO	DIESEL FILTERS	FILTRES DIESEL				
FILTRI OLIO	OIL FILTERS	FILTRES À HUILE				
GIUNTI	JOINTS	JOINTS				
KIT CUSCINETTI RUOTA	WHEEL BEARINGS	ROULEMENTS DE ROUE				
KIT DISTRIBUZIONE MOTORE	TIMING BELT KIT	KIT DE COURROIE DE DISTRIBUTION				
PASTIGLIE FRENO ANTERIORE	FRONT BRAKE PADS	PLAQUETTES DE FREIN AVANT				
PASTIGLIE FRENO POSTERIORE	REAR BRAKE PADS	PLAQUETTES DE FREIN ARRIERE				
PINZE FRENO ANTERIORI	FRONT BRAKE CALLIPERS	ETRIERS DE FREINS AVANT				
PINZE FRENO POSTERIORI	REAR BRAKE CALLIPERS	ETRIERS DE FREINS ARRIERE				
SEMIASSI	HALF SHAFTS	DEMI-ESSIEUX				
TENDICINGHIA DISTRIBUZIONE	TIMING BELT TENSIONER	TENDEUR DE COURROIE DE DISTRIBUTION			TDM0001	TDM0001 TDM0001
TESTE STERZO	STEERING BEARINGS	ROULEMENTS DE DIRECTION				

PIAGGIO	PIAGGIO	PIAGGIO	PIAGGIO	PIAGGIO	PIAGGIO	PIAGGIO	PIAGGIO	PIAGGIO	PIAGGIO	PIAGGIO	PIAGGIO
PORETR MULTITECH EURO4/5 - EURO5+	PORETR MULTITECH EURO6 - EURO6-C	PORETR MULTITECH EURO6 ENTRY LEVEL	PORETR MULTITECH MAXXI EURO4 - EURO5	PORETR MULTITECH MAXXI EURO6	PORTER	PORTER 1000 PICK-VAN	PORTER 1300 PICK-VAN	PORTER 16V PICK UP-MAXXI-GPL-4X4	PORTER 16V VAN	PORTER D120 E5	PORTER DIESEL 1200
10-15	15-20	17-20	10-15	15-19	92-98	92-09	92-09	98-09	98-07	11-15	95-00
1300cc 4T 4V	1300cc 4T 4V	1300cc 4T 4V	1300cc 4T 4V	1300cc 4T 4V	1000cc 4T	1000cc 4T	1300cc 4T	1300cc 4T 4V	1300cc 4T 4V	1200cc DIESEL	1200cc DIESEL
					CFMC001	CFMC001	CFMC001	CFMC001	CFMC001		CFMC001
						FAMC009	FAMC009		FAMC009	FAMC010	FAMC010
FCMC001	FCMC001	FCMC001	FCMC001	FCMC001	FCMC001	FCMC001	FCMC001		FCMC001		
											FGMC008
FOMC006	FOMC006	FOMC006	FOMC006	FOMC006	FOMC005	FOMC006	FOMC006	FOMC006	FOMC006		FOMC006
KCRM001					KCRM001	KCRM001	KCRM001	KCRM001	KCRM001	KCRM001	KCRM001
											KDM0001
											TDM0001
					TSMC001 TSMC002	TSMC001 TSMC002	TSMC001 TSMC002	TSMC001 TSMC002	TSMC001 TSMC002	TSMC001 TSMC002	TSMC001 TSMC002

PIAGGIO	PIAGGIO	PIAGGIO	PIAGGIO
PORTER DIESEL 1400	PORTER MAXXI D120 EUROS	PORTER MAXXI UP-DATE	PORTER PICK DIESEL
95-00	11-15	09-10	98-05
1400cc DIESEL	1200cc 4T 4V	1300cc 4T 4V	1400cc DIESEL

IT	EN	FR				
AMMORTIZZATORI ANTERIORI	FRONT SHOCK ABSORBERS	AMORTISSEURS AVANT				
AMMORTIZZATORI POSTERIORI	REAR SHOCK ABSORBERS	AMORTISSEURS ARRIERE				
CILINDRETTI FRENO	JOINTS	JOINTS		CFMC001		CFMC001
DISCHI FRENO ANTERIORI	FRONT BRAKE DISCS	DISQUES DE FREIN AVANT				
DISCHI FRENO POSTERIORI	REAR BRAKE DISCS	DISQUES DE FREINS ARRIERE				
DISCHI FRENO POSTERIORI VENTILATI	REAR VENTED BRAKE DISCS	DISQUES DE FREIN ARRIERE VENTILES				
FILTRI ARIA	AIR FILTERS	FILTRES À AIR		FAMC010	FAMC010	FAMC009 FAMC010
FILTRI CARBURANTE	GASOLINE FILTERS	FILTRES À ESSENCE				
FILTRI GASOLIO	DIESEL FILTERS	FILTRES DIESEL		FGMC008		FGMC008
FILTRI OLIO	OIL FILTERS	FILTRES À HUILE		FOMC006		FOMC006 FOMC006
GIUNTI	JOINTS	JOINTS				
KIT CUSCINETTI RUOTA	WHEEL BEARINGS	ROULEMENTS DE ROUE		KCRM001		KCRM001
KIT DISTRIBUZIONE MOTORE	TIMING BELT KIT	KIT DE COURROIE DE DISTRIBUTION		KDM001		KDM001
PASTIGLIE FRENO ANTERIORE	FRONT BRAKE PADS	PLAQUETTES DE FREIN AVANT				
PASTIGLIE FRENO POSTERIORE	REAR BRAKE PADS	PLAQUETTES DE FREIN ARRIERE				
PINZE FRENO ANTERIORI	FRONT BRAKE CALLIPERS	ETRIERS DE FREINS AVANT				
PINZE FRENO POSTERIORI	REAR BRAKE CALLIPERS	ETRIERS DE FREINS ARRIERE				
SEMIASSI	HALF SHAFTS	DEMI-ESSIEUX				
TENDICINGHIA DISTRIBUZIONE	TIMING BELT TENSIONER	TENDEUR DE COURROIE DE DISTRIBUTION		TDM001		TDM001
TESTE STERZO	STEERING BEARINGS	ROULEMENTS DE DIRECTION		TSMC001 TSMC002		TSMC001 TSMC002

PIAGGIO	PIAGGIO	PIAGGIO	PIAGGIO
PORTER UP-DATE	PORTER VAN DIESEL	QUARGO	QUARGO DIESEL
09-10	98-05	05-17	04-06
1300cc 4T 4V	1400cc DIESEL	500cc DIESEL	750cc DIESEL
CFMC001	CFMC001		
FAMC009	FAMC010		
FCMC001			
	FGMC008		
FOMC006	FOMC006		
KCRM001	KCRM001	KCRM001	
	KDM0001	KDM0001	KDM0001
	TDM0001	TDM0001	TDM0001
TSMC001 TSMC002			







***GUARNIZIONI
ATHENA***

GUARNIZIONI ATHENA

MARCA MAKE	MODELLO MODEL	CC CC	DA FROM	A TO	SERIE GUARNIZIONI MOTORE ENGINE GASKET SET	SERIE GUARNIZIONI SMERIGLIO CYLINDER/HEAD GASKET SET	SERIE PARAOLI MOTORE OIL SEAL ENGINE SET
ARCTIC CAT	BEAR CAT 2X4	454	1993	1998	P400510850454	P400510600454	
	BEAR CAT 4X4	454	1993	1998	P400510850454	P400510600454	
	DVX	400	2004	2008		P400510600036	
BOMBARDIER	DS	650	2000	2000	P400070850001	P400070600001	P400070400001
CAN-AM	TRAXTER	500	2000	2005	P400070850002	P400070600002	
	TRAXTER	650	2000	2000	P400070850002	P400070600002	
	OUTLANDER EFI / XT	1000	2012	2017	P400089900001	P400089600001	P400089400001
HONDA	OUTLANDER MAX LTD	800	2008	2008	P400089900002	P400089600002	P400089400002
	OUTLANDER MAX STD	800	2008	2008	P400089900002	P400089600002	P400089400002
	OUTLANDER STD	800	2008	2008	P400089900002	P400089600002	P400089400002
	OUTLANDER XT	800	2008	2008	P400089900002	P400089600002	P400089400002
	R OUTLANDER EFI/XT	800	2009	2012	P400089900002	P400089600002	P400089400002
	R OUTLANDER EFI/XT	800	2013	2015	P400089900001	P400089600001	P400089400001
	R OUTLANDER MAX EFI XMR	800	2013	2015		P400089600001	P400089400001
	R OUTLANDER MAX EFI/XT/LTD	800	2009	2012	P400089900002	P400089600002	P400089400002
	R OUTLANDER MAX EFI/XT/LTD	800	2013	2015	P400089900001	P400089600001	P400089400001
	R RENEGADE EFI	800	2009	2011	P400089900002	P400089600002	P400089400002
	ATC	70	1976	1985	P400210850073	P400210600073	
	ATC	90	1971	1978	P400210850093	P400210600090	
	ATC	110	1979	1985	P400210850111	P400210600111	
	ATC	185	1981	1983	P400510850185	P400210600185	
	ATC BIG RED / X / S	200	1981	1986	P400210850185		
	ATC BIG RED / X / S	200	1981	1985		P400210600185	
	ATC BIG RED / X / S	200	1982	1983	P400210850204		
ATC BIG RED / X / S	200	1984	1985	P400210850201			
ATC BIG RED / X / S	200	1986	1987	P400210850205	P400210600205		
ATC ES BIG RED / SX	250	1985	1987	P400210850258	P400210600300		
ATC M	125	1984	1985	P400210850130	P400210600130		
ATC M	125	1986	1988	P400210850133	P400210600133		
ATC R	250	1981	1984	P400210850255	P400210600255		
ATC R	250	1985	1986	P400210850256	P400210600256		
ATC X	350	1985	1986	P400210850354	P400210600354		
FL R ODYSSEY	350	1985	1985	P400210850356	P400210600356		
FL R PILOT	400	1989	1990	P400210850402	P400210600402		
FOREMAN	450	2006	2013	P400210850197	P400210600197	P400210400197	
MUV	700	2009	2013	P400210850199	P400210600199	P400210400199	
PIONEER	700	2014	2018	P400210850199	P400210600199	P400210400199	
TE RECON	250	2001	2018	P400210850164	P400210600164		
TM RECON ES	250	2001	2018	P400210850164	P400210600164		
TRX	70	1976	1985	P400210850073			
TRX	70	1976	1987		P400210600073		
TRX	70	1986	1987	P400210850078			
TRX	90	1993	2000	P400210850114			
TRX	90	2001	2013		P400210600171		
TRX	350	1986	1989	P400210850355	P400210600354		
TRX	350	2000	2004	P400210850063	P400210600063		
TRX AF	650	2003	2004	P400210850173	P400210600173		
TRX D FOURTRAX RANCHER TM/TE/FM/FE/EX SPORTRAX	350	2000	2004	P400210850063	P400210600063		

MARCA	MODELLO	CC	DA	A	SERIE GUARNIZIONI MOTORE	SERIE GUARNIZIONI SMERIGLIO	SERIE PARAOLI MOTORE
MAKE	MODEL	CC	FROM	TO	ENGINE GASKET SET	CYLINDER/HEAD GASKET SET	OIL SEAL ENGINE SET
HONDA	TRX ER	450	2006	2014	P400210850197	P400210600197	P400210400197
	TRX EX	250	2001	2019	P400210850164	P400210600164	
	TRX EX 4X4	400	1999	2004	P400210850404	P400210600404	P400210400404
	TRX EX SPORTRAX	300	1993	2008	P400210850265	P400210600265	
	TRX EX SPORTRAX	400	1999	2004	P400210850404		
	TRX EX SPORTRAX	400	1999	2005		P400210600404	P400210400404
	TRX EX SPORTRAX	400	2005	2014	P400210850195		
	TRX EX SPORTRAX	400	2006	2014		P400210600195	
	TRX EX SPORTRAX	400	2006	2013			P400210400195
	TRX FA	500	2001	2014	P400210850172	P400210600172	P400210400172
	TRX FA	500	2015	2019	P400210850305	P400210600305	
	TRX FA FOURTRAX RANCHER AT	400	2004	2007	P400210850196	P400210600196	P400210400196
	TRX FA/FE/TM/FPA/FPE/FPM	420	2008	2016	P400210850242	P400210600242	
	TRX FA/FE/TM/FPA/FPE/FPM	420	2009	2019	P400210850246	P400210600246	
	TRX FE FOURTRAX FOREMAN 4x4 ES	500	2006	2008	P400210850198	P400210600198	
	TRX FE/FM	500	2012	2016	P400210850305	P400210600305	
	TRX FGA FOURTRAX FOREMAN RUBICON	500	2001	2014	P400210850172	P400210600172	P400210400172
	TRX FGA FOURTRAX RANCHER	400	2004	2007	P400210850196	P400210600196	P400210400196
	TRX FM	420	2013	2019	P400210850246		
	TRX FM	420	2013	2018		P400210600246	
	TRX FORETRAX FOREMAN FE/FM	450	2002	2004	P400210850062	P400210600062	
	TRX FOURTRAX	90	2001	2020		P400210600171	
	TRX FOURTRAX	125	1985	1986	P400210850131	P400210600130	
	TRX FOURTRAX	125	1987	1988	P400210850133	P400210600133	
	TRX FOURTRAX	200	1984	1984	P400210850201	P400210600185	
	TRX FOURTRAX	200	1990	1991	P400210850222	P400210600205	
	TRX FOURTRAX	250	1985	1987	P400210850258	P400210600300	
	TRX FOURTRAX / TYPE II	200	1986	1998	P400210850222	P400210600205	
	TRX FOURTRAX FOREMAN FM/TM	500	2006	2011	P400210850198	P400210600198	
	TRX FOURTRAX FOREMAN FM/TM	500	2012	2019	P400210850305	P400210600305	
	TRX FOURTRAX RINCON	680	2006	2020	P400210850199	P400210600199	P400210400199
	TRX FPA	500	2012	2014	P400210850172	P400210600172	P400210400172
	TRX FW	400	1995	2003	P400210850403	P400210600403	
	TRX FW FOURTRAX	300	1988	2000	P400210850300	P400210600300	
	TRX R	450	2004	2005	P400210850179	P400210600179	
	TRX R	450	2006	2013	P400210850197	P400210600197	P400210400197
	TRX R FOURTRAX	250	1986	1989	P400210850260	P400210600260	
	TRX S/ES 4X4	450	1998	2001	P400210850062	P400210600062	
	TRX SPORTRAX	90	2001	2014		P400210600171	
	TRX X FOURTRAX	250	1987	1992	P400210850265	P400210600265	
TRX XX	700	2008	2009	P400210850241	P400210600241	P400210400241	
KAWASAKI	BRUTE FORCE 4X4 REALTREE HARDWOODS GREEN HD	750	2006	2020	P400250850029	P400250600029	P400250400029
	KEF LAKOTA SPORT	300	1995	2004	P400250850300	P400250600300	
	KFX	700	2004	2009	P400250850019	P400250600019	P400250400018
	KFX PRAIRIE 4X4	700	2004	2004	P400250850019	P400250600019	
	KFX R	450	2006	2014	P400250850057	P400250600024	P400250400024
	KFX SPORT	400	2003	2006	P400510850401	P400510600401	P400250400036
	KFX V FORCE	700	2004	2004	P400250850019	P400250600019	

GUARNIZIONI ATHENA

MARCA MAKE	MODELLO MODEL	CC CC	DA FROM	A TO	SERIE GUARNIZIONI MOTORE ENGINE GASKET SET	SERIE GUARNIZIONI SMERIGLIO CYLINDER/HEAD GASKET SET	SERIE PARAOLI MOTORE OIL SEAL ENGINE SET
KAWASAKI	KLF	110	1984	1988	P400250850111	P400250600111	
	KLF	185	1985	1988	P400250850185	P400250600185	
	KLF A BAYOU	300	1986	1987	P400250850303	P400250600303	
	KLF A1 / A11 BAYOU	220	1985	2002	P400250850220	P400250600220	
	KLF B BAYOU	300	1988	2004	P400250850300	P400250600300	
	KLF BAYOU	250	2003	2011	P400250850017	P400250600017	P400250400017
	KLF BAYOU	400	1993	1999	P400250850404	P400250600404	
	KLF C BAYOU 4X4	300	1988	2003	P400250850304		
	KLF C BAYOU 4X4	300	1998	2003		P400250600300	
	KLT	110	1984	1988	P400250850111	P400250600111	
	KLT	185	1985	1988	P400250850185	P400250600185	
	KLT A1	160	1985	1985	P400250850160	P400250600160	
	KLT A1 / A2 / P1 POLICE	250	1982	1982	P400250850265		
	KLT A1 / A2 / P1 POLICE	250	1982	1985		P400250600265	
	KLT A1 / A2 / P1 POLICE	250	1983	1985	P400250850261		
	KLT A1 / A4	200	1981	1983	P400250850207	P400250600203/1	
	KLT B1 / C1 / C2	200	1983	1984	P400250850203	P400250600203/1	
	KRF 7LE/NRA OUTDOORS TERYX 4x4	750	2008	2011	P400250850029	P400250600029	P400250400029
	KSF A MOJAVE	250	1987	2004	P400250850253	P400250600253	
	KSF TECATE 4	250	1987	1991	P400250850254	P400250600254	
	KVF A/B/C BRUTE FORCE 4x4i	750	2006	2019	P400250850029	P400250600029	P400250400029
	KVF B1/B2/B3 PRARIE	300	1999	2002		P400250600300	
	KVF BRUTE FORCE 4X4	650	2005	2013	P400250850028	P400250600028	P400250400028
	KVF BRUTE FORCE 4X4i	650	2008	2014	P400250850038	P400250600038	P400250400029
	KVF D1 / D2 PRAIRIE 4 X 4	400	1999	2002	P400250850014	P400250600404	
	KVF PRAIRIE 4X4	360	2003	2013	P400250850018	P400250600018	P400250400018
	KVF PRARIE 2WD OR 4WD	300	1999	2002		P400250600300	
	KVF PRARIE 2WD OR 4WD	400	1999	2000		P400250600404	
	KVF300CCF BRUTE FORCE	300	2012	2018	P400250850059	P400250600059	
	KXF	400	2003	2010	P400510850401	P400510600401	
	KXF A1 / A2 TECATE 4	250	1987	1991	P400250850254	P400250600254	
	PRAIRIE 4X4 HARDWOODS GREEN HD	360	2004	2011	P400250850018	P400250600018	P400250400018
	RANGER 4X4	400	2012	2013	P400427850005	P400427600005	
KTM	SX	450	2009	2010	P400270850036	P400270600036	P400270400036
	XC	450	2008	2009	P400270850048	P400270600019	P400270400002
	XC	525	2008	2010	P400270850046	P400270600021	P400270400002
KYMCO	KXR	50	2004	2018	P400210850024	P400210600024	P400210400024
	KXR	250	2003	2006	P400210850180	P400210600180	P400210400180
	MAXXER	50	2005	2018	P400210850024	P400210600024	P400210400024
	MAXXER HR	300	2005	2010	P400210850217	P400210600217	P400210400217
	MXER	50	2002	2004	P400210850024	P400210600024	P400210400024
	MXER	150	2002	2003	P400210850211		
	MXER	150	2002	2004		P400210600211	P400210400211
	MXU	150	2005	2006	P400210850211	P400210600211	P400210400211
	MXU	250	2005	2005	P400210850180	P400210600180	P400210400180
	MXU	300	2005	2010	P400210850217	P400210600217	P400210400217
	MXU	400	2008	2008	P400210850244	P400210600244	
MXU	500	2005	2006	P400210850212	P400210600212		

MARCA MAKE	MODELLO MODEL	CC CC	DA FROM	A TO	SERIE GUARNIZIONI MOTORE ENGINE GASKET SET	SERIE GUARNIZIONI SMERIGLIO CYLINDER/HEAD GASKET SET	SERIE PARAOLI MOTORE OIL SEAL ENGINE SET
KYMCO	MXU	500	2005	2010			P400210400212
	MXU	500	2007	2010	P400210850285	P400210600285	
	MXU SR	50	2006	2007	P400210850024	P400210600024	P400210400024
POLARIS	UXV	500	2008	2010	P400210850285	P400210600285	P400210400212
	2X4 / 4X4 MAGNUM	425	1995	1998	P400427850005	P400427600005	
	ALL MOTORS	425	1995	2012	P400427850005	P400427600005	
	ALL MOTORS 2-STROKE	350	1990	1993	P400427850004	P400427600004	P400427400002
	ATP 4X4	500	2004	2005	P400427850006	P400427600006	
	BIG BOSS	500	1996	2003	P400427850006	P400427600006	
	BIG BOSS 4x6, 6X6	250	1990	1993	P400427850001	P400427600001	P400427400001
	BIG BOSS 6X6	300	1994	2018	P400427850003	P400427600003	
	BIG BOSS L 6X6	400	1994	1997	P400427850002	P400427600002	
	CYCLONE	250	1987	2018	P400427850001	P400427600001	P400427400001
	HAWKEYE 2x2, 4x4	300	2007	2010	P400427850011	P400427600011	
	HAWKEYE HD 2X4	400	2013	2014	P400427850005	P400427600005	
	MAGNUM	500	1996	2003	P400427850006	P400427600006	
	MAGNUM 2X4 HDS / 4X4/MOSSY OAK	330	2003	2010	P400427850007		
	MAGNUM 2X4, 4X4	325	2000	2002	P400427850007		
	MAGNUM RMK	500	2002	2018	P400427850006	P400427600006	
	OUTLAW	90	2007	2016	P400427850015	P400427600015	
	OUTLAW	500	2006	2007	P400427870012	P400427620012	
	PHOENIX	200	2013	2020	P400427870010	P400427620010	
	PREDATOR	90	2003	2006	P400427850009	P400427600009	
	PREDATOR	500	2005	2007		P400427620012	
	PREDATOR	500	2007	2018	P400427870012		
	PREDATOR E/LE	500	2007	2018	P400427870012	P400427620012	
	PRO-LITE / 2X4 / 4X4	300	1994	1995	P400427850003	P400427600003	
	RANGER 2X4 / 4X4	500	2006	2013	P400427850006	P400427600006	
	RANGER 4x4	400	2012	2014	P400427850005	P400427600005	
	RANGER 4X4	500	2006	2014	P400427850006	P400427600006	
	RANGER 6X6	700	2003	2005	P400427870013		
	RANGER 6X6 FEI	700	2006	2018	P400427870013	P400427620013	
	RANGER CREW	500	2012	2018	P400427850006	P400427600006	
	RANGER RZR	800	2010	2018	P400427870013	P400427620013	
	RANGER RZR - UTV	170	2009	2016	P400427850020	P400427600020	
RANGER RZR - UTV	570	2012	2013	P400427870019	P400427620019		
RANGER RZR - UTV	570	2014	2018	P400427870023	P400427620023		
RANGER RZR XP - UTV	900	2011	2012	P400427870018	P400427620018		
RANGER RZR XP - UTV	900	2013	2016	P400427870021	P400427620021		
RANGER UTV	800	2011	2014	P400427870016	P400427620016		
RANGER XP 4X4 /HD /CREW	700	2005	2006	P400427870013	P400427620013		
RZR XP	1000	2013	2014	P400427870021	P400427620021		
SAWTOOTH	200	2007	2007	P400427870010	P400427620010		
SCRAMBLER	50	2003	2003	P400485850006	P400485600006		
SCRAMBLER	90	2001	2006	P400427850009	P400427600009		
SCRAMBLER	850	2014	2019	P400427870017	P400427620017		
SCRAMBLER 2X4	500	1996	2003	P400427850006	P400427600006		
SCRAMBLER 4X4	500	2001	2010	P400427850006	P400427600006		

GUARNIZIONI ATHENA

MARCA MAKE	MODELLO MODEL	CC CC	DA FROM	A TO	SERIE GUARNIZIONI MOTORE ENGINE GASKET SET	SERIE GUARNIZIONI SMERIGLIO CYLINDER/HEAD GASKET SET	SERIE PARAOLI MOTORE OIL SEAL ENGINE SET
POLARIS	SCRAMBLER 4x4 FREEDOM	500	2002	2018	P400427850006	P400427600006	
	SCRAMBLER X	500	2002	2018	P400427850006	P400427600006	
	SPORTSMAN	90	2001	2006	P400427850009	P400427600009	
	SPORTSMAN	90	2007	2016	P400427850015	P400427600015	
	SPORTSMAN	400	2003	2010	P400427850005	P400427600005	
	SPORTSMAN	550	2009	2014	P400427870014	P400427620014	
	SPORTSMAN 4x4	300	2008	2010	P400427850011	P400427600011	
	SPORTSMAN 4X4	335	2000	2002	P400427850008		
	SPORTSMAN 4X4	500	1996	2004	P400427850006	P400427600006	
	SPORTSMAN 6X6	500	2003	2010	P400427850006	P400427600006	
	SPORTSMAN EFI	500	2003	2010	P400427850006	P400427600001	
	SPORTSMAN EFI /EPS	550	2009	2013	P400427870014	P400427620014	
	SPORTSMAN EFI HO	800	2007	2010	P400427870013	P400427620013	
	SPORTSMAN EFI TOURING	500	2003	2010	P400427850006	P400427600006	
	SPORTSMAN EPS	550	2009	2013	P400427870014	P400427620014	
	SPORTSMAN FOREST	500	2013	2014	P400427850006	P400427600006	
	SPORTSMAN FOREST	550	2009	2013	P400427870014	P400427620014	
	SPORTSMAN FOREST	850	2009	2014	P400427870017	P400427620017	
	SPORTSMAN HO	400	2003	2014	P400427850005	P400427600005	
	SPORTSMAN HO 4X4	500	2003	2010	P400427850006	P400427600006	
	SPORTSMAN MV	850	2009	2014	P400427870017	P400427620017	
	SPORTSMAN SP/TOURING SP	850	2015	2018	P400427870017	P400427620017	
	SPORTSMAN TOURING EFI/EPS	550	2009	2013	P400427870014	P400427620014	
	SPORTSMAN TOURING EPS	550	2009	2013	P400427870014	P400427620014	
	SPORTSMAN TOURING EPS	850	2009	2014	P400427870017	P400427620017	
	SPORTSMAN TOURING EPS / XP	850	2009	2020	P400427870017	P400427620017	
	SPORTSMAN TOURING H.O. EPS	850	2009	2014	P400427870017	P400427620017	
	SPORTSMAN X2	550	2009	2013	P400427870014	P400427620014	
	SPORTSMAN X2	850	2009	2014	P400427870017	P400427620017	
	SPORTSMAN X2 EFI	550	2009	2013	P400427870014	P400427620014	
	SPORTSMAN X2 EFI	700	2007	2008	P400427870013	P400427620013	
	SPORTSMAN XP	550	2009	2013	P400427870014	P400427620014	
	SPORTSMAN XP / EPS	850	2009	2014	P400427870017	P400427620017	
	SPORTSMAN XP EPS	550	2009	2013	P400427870014	P400427620014	
	SPORTSMAN XP H.O. EPS	850	2009	2014	P400427870017	P400427620017	
	SPORTSMAN XP/X2 /EFI	850	2009	2014	P400427870017	P400427620017	
	TRAIL BLAZER	250	1990	2006	P400427850001	P400427600001	P400427400001
	TRAIL BLAZER	330	2008	2010	P400427850007		
	TRAIL BLAZER	400	2003	2018	P400427850002	P400427600002	
	TRAIL BOSS	330	2006	2013	P400427850007		
	TRAIL BOSS 2X4	250	1986	1999	P400427850001	P400427600001	P400427400001
	TRAIL BOSS 4X4	250	1986	1999	P400427850001	P400427600001	P400427400001
UTV RZR	900	2013	2014	P400427870022	P400427620022		
WORKER	500	2001	2002	P400427850006	P400427600006		
XP EFI	550	2009	2013	P400427870014	P400427620014		
XPEDITION 4X4	425	2000	2002	P400427850005	P400427600005		
XPLOER	400	1996	2000	P400427850002	P400427600002		
XPLOER 4x4	250	2000	2003	P400427850001	P400427600001	P400427400001	

MARCA MAKE	MODELLO MODEL	CC CC	DA FROM	A TO	SERIE GUARNIZIONI MOTORE ENGINE GASKET SET	SERIE GUARNIZIONI SMERIGLIO CYLINDER/HEAD GASKET SET	SERIE PARAOLI MOTORE OIL SEAL ENGINE SET
POLARIS	XPLORER 4X4	300	1994	1999	P400427850003	P400427600003	
	XPLORER 4X4	400	2001	2002	P400427850002	P400427600002	
	XPLORER 4X4	500	1997	2018	P400427850006	P400427600006	
	XPLORER L 4X4	400	1995	2000	P400427850002	P400427600002	
	XPRESS 2X4 / L	300	1994	1999	P400427850003	P400427600003	
	XPRESS L	400	1997	2018	P400427850002	P400427600002	
SUZUKI	ALT	50	1983	1984	P400510850013	P400510600013	
	ALT	185	1984	1985	P400510850188	P400510600188	
	ALT D / E / F / G	125	1983	1986	P400510850136	P400510600135	
	LT 4WDX	250	1987	2000	P400510850257	P400510600257	
	LT A	50	2002	2004	P400210850013	P400510600013	
	LT E	160	1989	2000	P400510850160	P400510600160	
	LT E QUAD	300	1987	1989	P400510850354	P400510600354	
	LT E QUADRUNNER	250	1985	1986	P400510850268	P400510600268	
	LT GE / SF / E / F	230	1985	1993	P400510850231	P400510600231	
	LT QUADRUNNER	50	1984	1990	P400510850013	P400510600013	
	LT QUADRUNNER	125	1983	1987	P400510850136	P400510600135	
	LT QUADRUNNER	185	1984	1987	P400510850188	P400510600188	
	LT QUADSPORT	80	1987	2004	P400510850086	P400510600086	
	LT R QUADRACER	500	1988	1992	P400510850504	P400510600504	
	LT R QUADRUNNER	250	1985	1986	P400510850260	P400510600260	
	LT RH / RJ / RK / RL	250	1987	1992	P400510850259	P400510600259	
	LT-A EIGER 2X4 AUTOMATIC	400	2003	2009	P400510850399	P400510600399	
	LT-A F EIGER 4X4 AUTOMATIC	400	2003	2009	P400510850399	P400510600399	
	LT-A F KINGQUAD 4X4	400	2008	2018	P400510850399	P400510600399	
	LT-A F VINSON AUT. 4X4	500	2000	2000	P400510850027		
	LT-A F VINSON AUT. 4X4	500	2000	2007		P400510600028	
	LT-A F VINSON AUT. 4X4	500	2002	2007	P400510850490		
	LT-A X KING QUAD	450	2007	2010	P400510850065	P400510600065	
	LT-A X KINGQUAD	750	2008	2019	P400510850056	P400510600056	P400510400056
	LT-F 4 WDX	250	1987	1997	P400510850274	P400510600274	
	LT-F 4 WDX / QUADRUNNER	250	1988	2002	P400510850257	P400510600257	
	LT-F EIGER 2X4	400	2003	2004	P400510850407	P400510600399	
	LT-F F	500	1998	2007	P400510850408	P400510600028	
	LT-F F EIGER 4X4	400	2003	2004	P400510850407	P400510600399	
	LT-F KINGQUAD FS 4x2	400	2008	2010	P400510850407	P400510600399	
	LT-F KINGQUAD FS 4x4	400	2008	2017	P400510850407		
	LT-F KINGQUAD FS 4x4	400	2008	2018		P400510600399	
	LT-F KINGQUAD FS 4x4	400	2018	2018	P400510850399		
	LT-F QUADRUNNER	160	1991	2004	P400510850160	P400510600160	
	LT-F/OZARK	250	2002	2016	P400510850390	P400510600257	
	LT-R QUADRACER	450	2006	2010	P400510850047	P400510600047	
LT-Z QUADSPORT	250	2008	2010	P400510850390	P400510600257		
LT-Z QUADSPORT	400	2003	2016	P400510850401	P400510600401		
LTA KING QUAD	700	2006	2007	P400510850056	P400510600056	P400510400056	
YAMAHA	GRIZZLY	300	2012	2013	P400485870185	P400485620185	
	KODIAK	700	2016	2018	P400485900196	P400485600196	P400485400196
	WOLVERINE	700	2016	2017	P400485900196	P400485600196	P400485400196

GUARNIZIONI ATHENA

MARCA MAKE	MODELLO MODEL	CC CC	DA FROM	A TO	SERIE GUARNIZIONI MOTORE ENGINE GASKET SET	SERIE GUARNIZIONI SMERIGLIO CYLINDER/HEAD GASKET SET	SERIE PARAOLI MOTORE OIL SEAL ENGINE SET
YAMAHA	YF S	60	1984	1987	P400485850060	P400485600060	
	YFA1 BREEZE	125	1989	2004	P400485850137	P400485600126	
	YFB TIMBERWOLF	250	1992	2002	P400485850225	P400485600225	
	YFM	200	1986	1989	P400485850200	P400485600201	
	YFM	700	2007	2009	P400485850078	P400485600078	P400485400216
	YFM AR KODIAK	400	2000	2004	P400485850062	P400485600062	
	YFM BIG BEAR	250	2005	2008	P400485850075	P400485600075	P400485400075
	YFM BIG BEAR 2x4 / 4X4	400	2004	2012	P400485850042	P400485600350	
	YFM BIG BEAR FW 4X4	400	2004	2010	P400485850042	P400485600350	
	YFM BIG BEAR HUNTER 4X4	400	2011	2012	P400485850042	P400485600350	
	YFM BRUIN	250	2005	2008	P400485850075	P400485600075	P400485400075
	YFM CHAMP	100	1987	1991	P400485850113	P400485600113	
	YFM FA KODIAK 4WD / HUNTER	450	2000	2019	P400485850062	P400485600062	
	YFM GRIZZLY	125	2004	2013	P400485850174	P400485600174	
	YFM GRIZZLY	600	1998	2001	P400485850063	P400485600063	
	YFM GRIZZLY	660	2006	2008	P400485850077	P400485600077	P400485400077
	YFM GRIZZLY 4X4	450	2007	2012	P400485850062	P400485600062	P400485400076
	YFM GRIZZLY 4x4	700	2007	2015	P400485850156	P400485600156	P400485400156
	YFM GRIZZLY 4x4	700	2016	2018	P400485900196	P400485600196	P400485400196
	YFM GRIZZLY 4X4 EPS	450	2011	2013	P400485850062	P400485600062	P400485400076
	YFM GRIZZLY 4X4 EPS HUNTER	450	2011	2014	P400485850062	P400485600062	P400485400076
	YFM GRIZZLY 4X4 HUNTER	450	2011	2012	P400485850062	P400485600062	P400485400076
	YFM GRIZZLY DUCKS UNLIMIT.ED	660	2006	2018	P400485850077	P400485600077	P400485400077
	YFM GRIZZLY ESP 4X4	700	2011	2013	P400485850156	P400485600156	P400485400156
	YFM GRIZZLY ESP 4X4 HUNTER	700	2011	2018	P400485850156	P400485600156	P400485400156
	YFM GRIZZLY ESP 4X4 SPECIAL	700	2011	2018	P400485850156	P400485600156	P400485400156
	YFM GRIZZLY HUNTER	600	2001	2018	P400485850063	P400485600063	
	YFM GRIZZLY HUNTER	660	2005	2008	P400485850077	P400485600077	P400485400077
	YFM GRIZZLY HUNTER 4x4	700	2007	2015	P400485850156	P400485600156	P400485400156
	YFM GRIZZLY HUNTER WETLAND	660	2005	2018	P400485850077	P400485600077	P400485400077
	YFM GRIZZLY/4x4/EPS/FI/HUNTER	550	2009	2014	P400485850193	P400485600193	P400485400156
	YFM KODIAK FW	400	1993	1998	P400485850350	P400485600350	
	YFM MOTO 4	225	1985	1988	P400485850225	P400485600225	
	YFM MOTO 4	250	1989	1991		P400485600225	
	YFM MOTO4	80	1985	2000	P400485850092	P400485600092	
	YFM N / DXS / DXW MOTO 4	200	1985	1985	P400485850203	P400485600206	
	YFM R RAPTOR	700	2007	2018	P400485850078	P400485600078	P400485400216
	YFM RAPTOR	90	2009	2013	P400485850186	P400485600186	
	YFM RAPTOR	125	2011	2013	P400485850157	P400485600157	
	YFM RAPTOR	250	2008	2013	P400485850166	P400485600166	
	YFM RAPTOR	350	2003	2013	P400485850059	P400485600059	
	YFM RAPTOR	660	2001	2004	P400485850041	P400485600041	
YFM RAPTOR	660	2001	2005			P400485400041	
YFM RAPTOR	700	2006	2018	P400485850078	P400485600078	P400485400216	
YFM RAPTOR GYTR ED	700	2007	2018	P400485850078	P400485600078	P400485400216	
YFM RAPTOR SPECIAL ED	700	2007	2017	P400485850078	P400485600078	P400485400216	
YFM RHINO	700	2004	2007			P400485400155	
YFM S RAPTOR	50	2004	2008	P400485850178	P400485600178		

MARCA MAKE	MODELLO MODEL	CC CC	DA FROM	A TO	SERIE GUARNIZIONI MOTORE ENGINE GASKET SET	SERIE GUARNIZIONI SMERIGLIO CYLINDER/HEAD GASKET SET	SERIE PARAOLI MOTORE OIL SEAL ENGINE SET
YAMAHA	YFM S WARRIOR	350	2004	2018			P400485400350
	YFM W / A / B	250	2003	2004	P400485850058	P400485600058	
	YFM WOLVERINE	350	2007	2010	P400485850076	P400485600076	P400485400076
	YFM WOLVERINE FXT 4x4	350	2000	2005	P400485850042	P400485600350	
	YFM WOLVRINE / 4WD	450	2007	2010	P400485850062	P400485600062	P400485400076
	YFM X WARRIOR	350	1987	2002			P400485400350
	YFM XL BEAR TRACKER	250	1998	2002	P400485850225	P400485600225	
	YFM XL BEAR TRACKER	250	2003	2004	P400485850058	P400485600058	
	YFM XR WARRIOR / ER MOTO4 / FW BIG BEAR	350	1987	2002	P400485850350	P400485600350	
	YFM XR WARRIOR / ER MOTO4 / FW BIG BEAR	350	2003	2005	P400485850059	P400485600059	
	YFM-GRIZZLY 2x2	350	2007	2011	P400485850076	P400485600076	P400485400076
	YFM-GRIZZLY 4x4	350	2007	2014	P400485850076	P400485600076	P400485400076
	YFM-GRIZZLY HUNTER 4x4	350	2011	2014	P400485850076	P400485600076	P400485400076
	YFM-GRIZZLY IRS 4x4	350	2011	2013	P400485850076	P400485600076	P400485400076
	YFS BLASTER	200	1988	2004	P400485850205	P400485600205	
	YFZ	450	2012	2013	P400485850053	P400485600053	P400485400404
	YFZ	450	2017	2017	P400485850264	P400485600069	
	YFZ BILL BALANCE EDITION	450	2010	2018	P400485850264	P400485600069	
	YFZ BILL BALANCE EDITION	450	2010	2010			P400485400069
	YFZ R	450	2009	2020	P400485850264	P400485600069	P400485400069
	YFZ S	450	2004	2008	P400485850053	P400485600053	
	YFZ S	450	2004	2004			P400485400404
	YFZ SPECIAL EDITION	450	2010	2018	P400485850264	P400485600069	
	YFZ SPECIAL EDITION	450	2010	2010			P400485400069
	YFZ X	450	2010	2018	P400485850264	P400485600069	
	YFZ X	450	2010	2010			P400485400069
	YFZ-BANSHEE	350	1987	2002	P400485850351/1	P400485600351/2	
	YFZ-BANSHEE	350	1987	2006			P400485400351
	YT	175	1982	1983	P400485850176	P400485600176	
	YT L / N / S	60	1984	1986	P400485850060	P400485600060	P400485400140
	YT TRI MOTO	125	1980	1985	P400485850132	P400485600132	
	YTM	200	1983	1985	P400485850203	P400485600206	
	YTM DR TRI MOTO	225	1986	1986	P400485850203	P400485600206	
	YXR RHINO	450	2007	2008	P400485850062	P400485600062	P400485400076
	YXR RHINO / SE	700	2008	2009	P400485850156	P400485600156	P400485400156
	YXR RHINO FAH REALTREE HD	450	2006	2018	P400485850062	P400485600062	P400485400076
YXR RHINO FH HUNTER	450	2007	2008	P400485850062	P400485600062	P400485400076	
YXR RHINO FSE SPECIAL EDITION	450	2007	2008	P400485850062	P400485600062	P400485400076	





**BATTERIE
MOTO
ATV - UTV
MARINE**

BATTERIE MOTO - ATV, UTV - MARINE

MARCA	MODELLO	CC	ANNO	BATTERIA RHIAG	BATTERIA MPT	BATTERIA EXIDE	BATTERIA YUASA
MAKE	MODEL	CC	YEAR	RHIAG BATTERY	MOTORPARTS BATTERY	EXIDE BATTERY	YUASA BATTERY
BATTERIE MOTO							
AEON (BENZAI)	Elite	125	12-	RHTX9-BS	0012330	ETX9-BS	YTX9-BS
	Elite	350	12-	RHTX12-BS	0012320	ETX12-BS	YTX12-BS
APRILIA	Urban	350	11-	RHTX12-BS	0012320	ETX12-BS	YTX12-BS
	AF-1 Futura/Europa	50	87-94	RHB4L-B	0012180	EB4L-B	YB4L-B
	AF-1 Futura/Europa	125	90-00	RHB9-B		EB9-B	YB9-B
	AF-1 Project 108/Replica	125	-94	RHB9-B		EB9-B	YB9-B
	AF-1 Sintesi /S Relica	125	88-90	RHB9-B		EB9-B	YB9-B
	AF-1 Sintesi Sport Pro	125	-94	RHB9-B		EB9-B	YB9-B
	Amico GL/LK/LX/Sport	50	92-97	RHB4L-B	0012180	EB4L-B	YB4L-B
	AREA 51	50	98-00	RHB4L-B	0012180	EB4L-B	YB4L-B
	Atlantic	200	03-05	RHB12AL-A	0012340	EB12AL-A	YB12AL-A
	Atlantic	250	03-07	RHB12AL-A	0012340	EB12AL-A	YB12AL-A
	Atlantic	300	10-	RHB12AL-A	0012340	EB12AL-A	YB12AL-A
	Atlantic	500	06-	RHTX12-BS	0012320	ETX12-BS	YTX12-BS
	Atlantic Sprint	400	05-07	RHTX12-BS	0012320	ETX12-BS	YTX12-BS
	Atlantic Sprint	500	05-07	RHTX12-BS	0012320	ETX12-BS	YTX12-BS
	Atlantic/Eu3	125	02-07	RHB12AL-A	0012340	EB12AL-A	YB12AL-A
	Classic	125	95-99	RHB9-B		EB9-B	YB9-B
	Classic50	50	92-99	RHB4L-B	0012180	EB4L-B	YB4L-B
	Custom	125	-	RHB4L-B	0012180	EB4L-B	YB4L-B
	Dorsoduro	750	08-10	RHTX14-BS	0012390	ETX14-BS	YTX14-BS
	Dorsoduro	1200	10-11	RHTX14-BS	0012390	ETX14-BS	YTX14-BS
	Dorsoduro ABS	750	-	RHTX14-BS	0012390	ETX14-BS	YTX14-BS
	Dorsoduro ABS	1200	12-	RHTX14-BS	0012390	ETX14-BS	YTX14-BS
	Dorsoduro USA	750	-	RHTX14-BS	0012390	ETX14-BS	YTX14-BS
	Enduro	450	-	RHTX7A-BS	0012350	ETX7A-BS	YTX7A-BS
	Enduro	550	-	RHTX7A-BS	0012350	ETX7A-BS	YTX7A-BS
	ET	50	-	RHB4L-B	0012180	EB4L-B	YB4L-B
	ETV Capo Nord	1000	01-07	RHTX14-BS	0012390	ETX14-BS	YTX14-BS
	ETX E-Starter	125	-	RHB9-B		EB9-B	YB9-B
	Gulliver AC/LC	50	95-98	RHB4L-B	0012180	EB4L-B	YB4L-B
	H2O	50	00-	RHB4L-B	0012180	EB4L-B	YB4L-B
	Habana, Custom	50	99	RHB4L-B	0012180	EB4L-B	YB4L-B
	Habana, Custome	125	99-00	RHB9-B		EB9-B	YB9-B
	Hyperstrada	821	13-	RHT12B-BS	0012550	ET12B-BS	YT12B-BS
	LC	50	-	RHB4L-B	0012180	EB4L-B	YB4L-B
Leonado	300	02-04	RHB12AL-A	0012340	EB12AL-A	YB12AL-A	
Leonardo	125	96-01	RHB12AL-A	0012340	EB12AL-A	YB12AL-A	
Leonardo 150	150	00-04	RHB12AL-A	0012340	EB12AL-A	YB12AL-A	
Leonardo ST	125	01-04	RHB12AL-A	0012340	EB12AL-A	YB12AL-A	
Leonardo/St	250	99-04	RHB12AL-A	0012340	EB12AL-A	YB12AL-A	
MANA	800	-	RHTX14-BS	0012390	ETX14-BS	YTX14-BS	
Mana	850	08-10	RHTX14-BS	0012390	ETX14-BS	YTX14-BS	
MANA ABS	850	-	RHTX14-BS	0012390	ETX14-BS	YTX14-BS	
MANA CND	850	-	RHTX14-BS	0012390	ETX14-BS	YTX14-BS	
MANA USA	850	-	RHTX14-BS	0012390	ETX14-BS	YTX14-BS	
Mc Gulliver	50	00-	RHB4L-B	0012180	EB4L-B	YB4L-B	
Mojito	50	04-08	RHB4L-B	0012180	EB4L-B	YB4L-B	
Mojito	150	-	RHTX7L-BS	0012430	ETX7L-BS	YTX7L-BS	

MARCA	MODELLO	CC	ANNO	BATTERIA RHIAG	BATTERIA MPT	BATTERIA EXIDE	BATTERIA YUASA
MAKE	MODEL	CC	YEAR	RHIAG BATTERY	MOTORPARTS BATTERY	EXIDE BATTERY	YUASA BATTERY
APRILIA	Mojito 25 KM/H FL	50	-	RHB4L-B	0012180	EB4L-B	YB4L-B
	Mojito custom/retro	50	99-07	RHB4L-B	0012180	EB4L-B	YB4L-B
	Mojito FL	50	-	RHB4L-B	0012180	EB4L-B	YB4L-B
	Mojito RetrÃ /Custom	125	03-08	RHTX7L-BS	0012430	ETX7L-BS	YTX7L-BS
	Motard	450	-	RHTX7A-BS	0012350	ETX7A-BS	YTX7A-BS
	Motard	550	-	RHTX7A-BS	0012350	ETX7A-BS	YTX7A-BS
	Moto 6.5	650	95-99	RHB12AL-A	0012340	EB12AL-A	YB12AL-A
	Mx	50	04	RHB4L-B	0012180	EB4L-B	YB4L-B
	MX-125	125	04-06	RHB4L-B	0012180	EB4L-B	YB4L-B
	MXV	450	-	RHTX7A-BS	0012350	ETX7A-BS	YTX7A-BS
	Pegaso	50	00-	RHB4L-B	0012180	EB4L-B	YB4L-B
	Pegaso	50	92-94	RHB4L-B	0012180	EB4L-B	YB4L-B
	Pegaso	125	-95	RHB9-B		EB9-B	YB9-B
	Pegaso	650	00-03	RHB12AL-A	0012340	EB12AL-A	YB12AL-A
	Pegaso 3/IE	650	97-00/01-04	RHB12AL-A	0012340	EB12AL-A	YB12AL-A
	Pegaso Strada, Factory Trail	1000	09-10	RHTX12-BS	0012320	ETX12-BS	YTX12-BS
	Pegaso Strada/ Factory/ Trail (660)	650	05-10	RHTX12-BS	0012320	ETX12-BS	YTX12-BS
	Rally	50	04-05	RHB4L-B	0012180	EB4L-B	YB4L-B
	Rally AC/LC	50	95-03	RHB4L-B	0012180	EB4L-B	YB4L-B
	Rambla	125	08	RHTX12-BS	0012320	ETX12-BS	YTX12-BS
	Rambla	250	-	RHTX12-BS	0012320	ETX12-BS	YTX12-BS
	Red Rose/Classic	50	89-92	RHB4L-B	0012180	EB4L-B	YB4L-B
	Red Rose/Classic	125	-97	RHB9-B		EB9-B	YB9-B
	Replica	50	00-	RHB4L-B	0012180	EB4L-B	YB4L-B
	Rs	50	06-08	RHB4L-B	0012180	EB4L-B	YB4L-B
	Rs	125	92-08	RHB9-B		EB9-B	YB9-B
	RS 125 11 KW	125	-	RHB9-B		EB9-B	YB9-B
	RS 125 F.P.	125	-	RHB9-B		EB9-B	YB9-B
	RS 125 F.P. USA	125	-	RHB9-B		EB9-B	YB9-B
	RS 50/Extrema	50	97-05	RHB4L-B	0012180	EB4L-B	YB4L-B
	RS Extrema, RX	125	-97	RHB9-B		EB9-B	YB9-B
	RS Replica	125	-93	RHB9-B		EB9-B	YB9-B
	RS Replica	250	95-01	RHB4L-B	0012180	EB4L-B	YB4L-B
	RS250	250	00-04	RHB4L-B	0012180	EB4L-B	YB4L-B
	RS4 125	125	11-	RHTX7L-BS	0012430	ETX7L-BS	YTX7L-BS
	RS4 50	50	11-	RHTX5L-BS	0012380	ETX5L-BS	YTX5L-BS
	RS50	50	06-10	RHTX5L-BS	0012380	ETX5L-BS	YTX5L-BS
	RST Futura	1000	01-03	RHTX12-BS	0012320	ETX12-BS	YTX12-BS
	RSV	1000	01-02	RHTX12-BS	0012320	ETX12-BS	YTX12-BS
	RSV	1000	98-00	RHTX14-BS	0012390	ETX14-BS	YTX14-BS
	RSV 1000 4V Factory	1000	-	RHTZ10S-BS	0012540		YTZ10S-BS
	RSV 1000 Factory USA	1000	-	RHTX12-BS	0012320	ETX12-BS	YTX12-BS
	RSV 1000 Mille	1000	00	RHTX14-BS	0012390	ETX14-BS	YTX14-BS
	RSV 1000 Mille	1000	00-03	RHTX12-BS	0012320	ETX12-BS	YTX12-BS
	RSV 1000 Mille R	1000	00-05	RHTX12-BS	0012320	ETX12-BS	YTX12-BS
	RSV 1000 Mille SP	1000	99	RHTX12-BS	0012320	ETX12-BS	YTX12-BS
	RSV 1000 R USA	1000	-	RHTX12-BS	0012320	ETX12-BS	YTX12-BS
	RSV R	1000	01-07	RHTX12-BS	0012320	ETX12-BS	YTX12-BS
	RSV R	1000	98-00	RHTX14-BS	0012390	ETX14-BS	YTX14-BS
	RSV R FACTORY	1000	04-10	RHTX12-BS	0012320	ETX12-BS	YTX12-BS

BATTERIE MOTO - ATV, UTV - MARINE

MARCA MAKE	MODELLO MODEL	CC CC	ANNO YEAR	BATTERIA RHIAG RHIAG BATTERY	BATTERIA MPT MOTORPARTS BATTERY	BATTERIA EXIDE EXIDE BATTERY	BATTERIA YUASA YUASA BATTERY
APRILIA	RSV SP	1000	-	RHTX12-BS	0012320	ETX12-BS	YTX12-BS
	RX 125 11 KW	125	-	RHB4L-B	0012180	EB4L-B	YB4L-B
	RX 125 F.P.	125	-	RHB4L-B	0012180	EB4L-B	YB4L-B
	RX-50	50	89-07	RHB4L-B	0012180	EB4L-B	YB4L-B
	RXV	450	08	RHTZ10S-BS	0012540		YTZ10S-BS
	RXV	550	08	RHTZ10S-BS	0012540		YTZ10S-BS
	RXV 450 CND	450	-	RHTX7A-BS	0012350	ETX7A-BS	YTX7A-BS
	RXV 450 USA	450	-	RHTX7A-BS	0012350	ETX7A-BS	YTX7A-BS
	RXV 550 CND	550	-	RHTX7A-BS	0012350	ETX7A-BS	YTX7A-BS
	RXV 550 USA	550	-	RHTX7A-BS	0012350	ETX7A-BS	YTX7A-BS
	RXV450	450	10-	RHTX7A-BS	0012350	ETX7A-BS	YTX7A-BS
	RXV550	550	10-	RHTX7A-BS	0012350	ETX7A-BS	YTX7A-BS
	Scarabeo	50	93-08	RHB4L-B	0012180	EB4L-B	YB4L-B
	Scarabeo	125	08-10	RHTX12-BS	0012320	ETX12-BS	YTX12-BS
	Scarabeo	150	00-04	RHB12AL-A	0012340	EB12AL-A	YB12AL-A
	Scarabeo	200	09-11	RHB12AL-A	0012340	EB12AL-A	YB12AL-A
	Scarabeo	250	04-06	RHB12AL-A	0012340	EB12AL-A	YB12AL-A
	Scarabeo	400	-	RHTX12-BS	0012320	ETX12-BS	YTX12-BS
	Scarabeo 100 2T	100	00-	RHTX5L-BS	0012380	ETX5L-BS	YTX5L-BS
	Scarabeo 150	150	99-04	RHB12AL-A	0012340	EB12AL-A	YB12AL-A
	Scarabeo 4t	50	02-08	RHB9-B		EB9-B	YB9-B
	Scarabeo 4T	100	01-08	RHB9-B		EB9-B	YB9-B
	Scarabeo 4T	125	03	RHB12AL-A	0012340	EB12AL-A	YB12AL-A
	Scarabeo 4T	125	99	RHB12AL-A	0012340	EB12AL-A	YB12AL-A
	Scarabeo 4T	200	03	RHB12AL-A	0012340	EB12AL-A	YB12AL-A
	Scarabeo 4T USA	100	-	RHB9-B		EB9-B	YB9-B
	Scarabeo Ditech	50	01-04	RHTX5L-BS	0012380	ETX5L-BS	YTX5L-BS
	Scarabeo eu	50	-	RHB9-B		EB9-B	YB9-B
	Scarabeo L	250	-	RHTX12-BS	0012320	ETX12-BS	YTX12-BS
	Scarabeo L USA	500	-	RHTX12-BS	0012320	ETX12-BS	YTX12-BS
	Scarabeo Light	400	06-08	RHTX12-BS	0012320	ETX12-BS	YTX12-BS
	Scarabeo Light, Special	300	09-10	RHTX12-BS	0012320	ETX12-BS	YTX12-BS
	Scarabeo Motore Rotax	125	99-03	RHB12AL-A	0012340	EB12AL-A	YB12AL-A
	Scarabeo Motore Rotax	150	99-03	RHB12AL-A	0012340	EB12AL-A	YB12AL-A
	Scarabeo Motore Rotax	200	99-03	RHB12AL-A	0012340	EB12AL-A	YB12AL-A
	Scarabeo Scooter	500	09-10	RHTX12-BS	0012320	ETX12-BS	YTX12-BS
	Scarabeo/Eu3	125	03-07	RHB12AL-A	0012340	EB12AL-A	YB12AL-A
	Scrabee Light	500	06-08	RHTX12-BS	0012320	ETX12-BS	YTX12-BS
	Shiver	750	08-12	RHTX14-BS	0012390	ETX14-BS	YTX14-BS
	SHIVER ABS	750	-	RHTX14-BS	0012390	ETX14-BS	YTX14-BS
	SHIVER CND	750	-	RHTX14-BS	0012390	ETX14-BS	YTX14-BS
	SHIVER USA	750	-	RHTX14-BS	0012390	ETX14-BS	YTX14-BS
	SL Falco	1000	00-02	RHTX14-BS	0012390	ETX14-BS	YTX14-BS
	Sonic	50	98-07	RHB4L-B	0012180	EB4L-B	YB4L-B
	Sonic Acqua	50	-	RHB4L-B	0012180	EB4L-B	YB4L-B
Sonic, GP	50	98-08	RHB4L-B	0012180	EB4L-B	YB4L-B	
Sport City	125	04-11	RHT12B-BS	0012550	ET12B-BS	YT12B-BS	
Sport city	125	08-	RHTX12-BS	0012320	ETX12-BS	YTX12-BS	
Sport city	200	09-	RHTX12-BS	0012320	ETX12-BS	YTX12-BS	
Sport City	250	06-07	RHT12B-BS	0012550	ET12B-BS	YT12B-BS	

MARCA	MODELLO	CC	ANNO	BATTERIA RHIAG	BATTERIA MPT	BATTERIA EXIDE	BATTERIA YUASA
MAKE	MODEL	CC	YEAR	RHIAG BATTERY	MOTORPARTS BATTERY	EXIDE BATTERY	YUASA BATTERY
APRILIA	Sport City	250	09-11	RHTX12-BS	0012320	ETX12-BS	YTX12-BS
	Sport City	250	09-12	RHTX12-BS	0012320	ETX12-BS	YTX12-BS
	Sport City One	50	08	RHB9-B		EB9-B	YB9-B
	Sport City One	125	08	RHB9-B		EB9-B	YB9-B
	Sport city rest	125	-	RHTX12-BS	0012320	ETX12-BS	YTX12-BS
	Sport city rest	200	-	RHTX12-BS	0012320	ETX12-BS	YTX12-BS
	Sport city rest	300	08-10	RHTX12-BS	0012320	ETX12-BS	YTX12-BS
	Sport city USA	250	-	RHTX12-BS	0012320	ETX12-BS	YTX12-BS
	Sport city USA rest	250	-	RHB12AL-A	0012340	EB12AL-A	YB12AL-A
	Sportcity	200	04-06	RHT12B-BS	0012550	ET12B-BS	YT12B-BS
	SR CARB	50	08	RHB9-B		EB9-B	YB9-B
	SR Ditech	50	00-05	RHTX5L-BS/RHB4L-B/ RHTZ7S-BS	0012380/0012180	ETX5L-BS/EB4L-B	YTX5L-BS/YB4L-B
	SR Factory	50	04-08	RHB9-B		EB9-B	YB9-B
	SR IE	50	08	RHB9-B		EB9-B	YB9-B
	SR IE 25 KM/H	50	-	RHB9-B		EB9-B	YB9-B
	SR IE CND	50	-	RHB9-B		EB9-B	YB9-B
	SR IE USA	50	-	RHB9-B		EB9-B	YB9-B
	SR LC/Netscaper	50	-97	RHB4L-B	0012180	EB4L-B	YB4L-B
	SR Netscaper	50	-97	RHB4L-B	0012180	EB4L-B	YB4L-B
	SR Replica/Racing	50	97-00	RHB4L-B	0012180	EB4L-B	YB4L-B
	SR Stealth/WWW	50	97-99	RHB4L-B	0012180	EB4L-B	YB4L-B
	SR Street carburatore	50	03-08	RHB4L-B	0012180	EB4L-B	YB4L-B
	SR Street iniezione	50	03-08	RHTX5L-BS	0012380	ETX5L-BS	YTX5L-BS
	SR Urban/Viper	50	00-10	RHB4L-B	0012180	EB4L-B	YB4L-B
	SR125	125	99-01	RHTX7L-BS	0012430	ETX7L-BS	YTX7L-BS
	SR150	150	99-01	RHTX7L-BS	0012430	ETX7L-BS	YTX7L-BS
	SR50	50	00-01	RHB4L-B	0012180	EB4L-B	YB4L-B
	SR50 de	50	-	RHB4L-B	0012180	EB4L-B	YB4L-B
	SR50 Ditech	50	01-05	RHTX5L-BS	0012380	ETX5L-BS	YTX5L-BS
	ST, STX E-Starter	125	-	RHB9-B		EB9-B	YB9-B
	SVX450	450	10	RHTX7A-BS	0012350	ETX7A-BS	YTX7A-BS
	SVX550	550	10-	RHTX7A-BS	0012350	ETX7A-BS	YTX7A-BS
	SX 11 KW	125	-	RHB4L-B	0012180	EB4L-B	YB4L-B
	SX F.P.	125	-	RHB4L-B	0012180	EB4L-B	YB4L-B
	SXV 450 CND	450	-	RHTX7A-BS	0012350	ETX7A-BS	YTX7A-BS
	SXV 450 US	450	-	RHTZ10S-BS	0012540		YTZ10S-BS
	SXV 550 CND	550	-	RHTX7A-BS	0012350	ETX7A-BS	YTX7A-BS
	SXV 550 USA	550	-	RHTZ10S-BS	0012540		YTZ10S-BS
	Tuareg E-Starter	125	-	RHB9-B		EB9-B	YB9-B
	Tuareg Rally/Wind	50	90-05	RHB4L-B	0012180	EB4L-B	YB4L-B
	Tuareg Rally/Wind	125	88-94	RHB9-B		EB9-B	YB9-B
	Tuareg Wind	350	88-94	RHB9-B		EB9-B	YB9-B
	Tuono	50	03-04	RHB4L-B	0012180	EB4L-B	YB4L-B
	Tuono	125	03-04	RHB9-B		EB9-B	YB9-B
	Tuono Factory USA	1000	-	RHTX12-BS	0012320	ETX12-BS	YTX12-BS
	Tuono Fighter	1000	04	RHTX12-BS	0012320	ETX12-BS	YTX12-BS
	Tuono Fighter	1000	03-	RHTX12-BS	0012320	ETX12-BS	YTX12-BS
Tuono R CND	1000	-	RHTX12-BS	0012320	ETX12-BS	YTX12-BS	
Tuono R USA	1000	-	RHTX12-BS	0012320	ETX12-BS	YTX12-BS	
Tuono R-Factory	1000	06-08	RHTX12-BS	0012320	ETX12-BS	YTX12-BS	
Tuono V4 R- APRC	1000	11-	RHTX12-BS	0012320	ETX12-BS	YTX12-BS	

BATTERIE MOTO - ATV, UTV - MARINE

MARCA MAKE	MODELLO MODEL	CC CC	ANNO YEAR	BATTERIA RHIAG RHIAG BATTERY	BATTERIA MPT MOTORPARTS BATTERY	BATTERIA EXIDE EXIDE BATTERY	BATTERIA YUASA YUASA BATTERY
APRILIA ATK	Turono V4R	1000	-11	RHTZ10S-BS	0012540		YTZ10S-BS
	Tutti i modelli (Electric-Start)		91-95	RHTX9-BS	0012330	ETX9-BS	YTX9-BS
BENELLI	Tutti i modelli (Electric-Start)		96-01	RHTX7L-BS	0012430	ETX7L-BS	YTX7L-BS
	491	50	98-04	RHB4L-B	0012180	EB4L-B	YB4L-B
	350RS	350	00-	RH60-N24AL-B			
	4 Zyt. (Cyl.d.)	254	80-82	RHB9-B		EB9-B	YB9-B
	4 Zyt. (Cyl.d.)	354	78-89	RHB9-B		EB9-B	YB9-B
	491 GT/Sport/Racing	50	-97	RHB4L-B	0012180	EB4L-B	YB4L-B
	491 k2	491	-	RHB4L-B	0012180	EB4L-B	YB4L-B
	900 (6 Cil)	900	-	RH60-N30L-AHD	0012730		53030
	Adiva	125	00-02	RHTX14-BS	0012390	ETX14-BS	YTX14-BS
	Adiva 150	150	00	RHTX14-BS	0012390	ETX14-BS	YTX14-BS
	Adiva 150	150	00-	RHTX9-BS/RHB9-B	0012330	ETX9-BS/EB9-B	YTX9-BS/YB9-B
	C2 Long St	50	81	RHB4L-B	0012180	EB4L-B	YB4L-B
	Century 1130 Racer	1130	12-	RHTZ14S-BS	0012580		YTZ14S-BS
	CS	125	-	RHB9-B		EB9-B	YB9-B
	Devil	80	94-95	RHB4L-B	0012180	EB4L-B	YB4L-B
	Devil E-Starter	50	94-95	RHB4L-B	0012180	EB4L-B	YB4L-B
	G2	50	81-85	RHB4L-B	0012180	EB4L-B	YB4L-B
	Jarno E-Starter	125	00-	RHB9-B		EB9-B	YB9-B
	K2	50	97-01	RHB4L-B	0012180	EB4L-B	YB4L-B
	K2	100	99-01	RHB4L-B	0012180	EB4L-B	YB4L-B
	KBX	80	94	RHB4L-B	0012180	EB4L-B	YB4L-B
	KBX Race	50	94	RHB4L-B	0012180	EB4L-B	YB4L-B
	Naked	50	02-04	RHB4L-B	0012180	EB4L-B	YB4L-B
	Pepe	50	07	RHB4L-B	0012180	EB4L-B	YB4L-B
	Pepe	50	99-04	RHB4L-B	0012180	EB4L-B	YB4L-B
	Scooty LX/DLX	50	94	RHB4L-B	0012180	EB4L-B	YB4L-B
	Sprint	50	76	RHB4L-B	0012180	EB4L-B	YB4L-B
	TNT	1130	05-07	RHTZ14S-BS	0012580		YTZ14S-BS
	TNT 899	900	08	RHTZ14S-BS	0012580		YTZ14S-BS
	Tornado	900	02-05	RHT12B-BS	0012550	ET12B-BS	YT12B-BS
	Tornado	1130	07	RHTZ14S-BS	0012580		YTZ14S-BS
	TRE K, Amazonas, Borse	1130	12-	RHTZ14S-BS	0012580		YTZ14S-BS
TRE-K	1130	07-08	RHTZ14S-BS	0012580		YTZ14S-BS	
Velvet	125	99-08	RHTX9-BS	0012330	ETX9-BS	YTX9-BS	
Velvet	150	10-	RHTX9-BS	0012330	ETX9-BS	YTX9-BS	
Velvet	250	99-04	RHTX9-BS	0012330	ETX9-BS	YTX9-BS	
Velvet	400	03-04	RHTX14-BS	0012390	ETX14-BS	YTX14-BS	
BETA MOTOR	Adventure	50	-	RHB4L-B	0012180	EB4L-B	YB4L-B
ALP	200	03-	RHTX7L-BS	0012430	ETX7L-BS	YTX7L-BS	
ALP 4.0	400	-	RHTX7L-BS	0012430	ETX7L-BS	YTX7L-BS	
Alp Motard 4.0	350	03-08	RHTX7L-BS	0012430	ETX7L-BS	YTX7L-BS	
Ark Air Cooled	50	98-00	RHB4L-B	0012180	EB4L-B	YB4L-B	
Ark Air/Ark Lc	50	96-07	RHB4L-B	0012180	EB4L-B	YB4L-B	
Chrono	50	95	RHB4L-B	0012180	EB4L-B	YB4L-B	
Eikon	50	99-03	RHB4L-B	0012180	EB4L-B	YB4L-B	
Eikon	150	00-02	RHTX9-BS	0012330	ETX9-BS	YTX9-BS	
Eikon, Afrika	125	00-02	RHB4L-B	0012180	EB4L-B	YB4L-B	
EURO	300	-	RHTX9-BS	0012330	ETX9-BS	YTX9-BS	
Fhrona	50	-	RHB4L-B	0012180	EB4L-B	YB4L-B	

MARCA MAKE	MODELLO MODEL	CC CC	ANNO YEAR	BATTERIA RHIAG RHIAG BATTERY	BATTERIA MPT MOTORPARTS BATTERY	BATTERIA EXIDE EXIDE BATTERY	BATTERIA YUASA YUASA BATTERY	
BETA MOTOR	JONATHAN	300	-	RHTX9-BS	0012330	ETX9-BS	YTX9-BS	
	MOTARD	400	-	RHTX7L-BS	0012430	ETX7L-BS	YTX7L-BS	
	Quadra	50	95-99	RHB4L-B	0012180	EB4L-B	YB4L-B	
	Squirrel	50	98-00	RHB4L-B	0012180	EB4L-B	YB4L-B	
	Supermoto	75	00-01	RHB4L-B	0012180	EB4L-B	YB4L-B	
	Tempo	50	94-99	RHB4L-B	0012180	EB4L-B	YB4L-B	
BIG DOG	YB10 Dieci	1000	00-	RHTX14-BS	0012390	ETX14-BS	YTX14-BS	
	Aeroglide	1340	-	RHTX20L-BS	0012640		YTX20L-BS	
	Aerosport	1340	-	RHTX20L-BS	0012640		YTX20L-BS	
	Aerosport	1442	-	RHTX20L-BS	0012640		YTX20L-BS	
	Boxer	1750	-	RHTX20L-BS	0012640		YTX20L-BS	
	Bulldog	1442	-	RHTX20L-BS	0012640		YTX20L-BS	
	Bulldog	1750	-	RHTX20L-BS	0012640		YTX20L-BS	
	Coyote	1340	-	RHTX20L-BS	0012640		YTX20L-BS	
	Husky	1750	-	RHTX20L-BS	0012640		YTX20L-BS	
	Husky / Husky XT	1750	-	RHTX20L-BS	0012640		YTX20L-BS	
	Mastiff	1750	-	RHTX20L-BS	0012640		YTX20L-BS	
	Pit-Bull	1442	-	RHTX20L-BS	0012640		YTX20L-BS	
	Pit-Bull	1750	-	RHTX20L-BS	0012640		YTX20L-BS	
	Proglide	1340	-	RHTX20L-BS	0012640		YTX20L-BS	
	Prosport	1442	-	RHTX20L-BS	0012640		YTX20L-BS	
	Prosport	1750	-	RHTX20L-BS	0012640		YTX20L-BS	
	Prosport 18	1750	-	RHTX20L-BS	0012640		YTX20L-BS	
	Vintage	1340	-	RHTX20L-BS	0012640		YTX20L-BS	
	Vintage Classic	1750	-	RHTX20L-BS	0012640		YTX20L-BS	
	Vintage Classic / Light	1340	-	RHTX20L-BS	0012640		YTX20L-BS	
	Vintage Classic / Light	1442	-	RHTX20L-BS	0012640		YTX20L-BS	
	Vintage Classic / Light	1570	-	RHTX20L-BS	0012640		YTX20L-BS	
	Vintage Sport	1750	-	RHTX20L-BS	0012640		YTX20L-BS	
	Wolf	1750	-	RHTX20L-BS	0012640		YTX20L-BS	
	BIMOTA	DB3 Mantra	900	97-99	RHTX7L-BS	0012430	ETX7L-BS	YTX7L-BS
		SB6, SB7	1100	95-97	RHTX7L-BS	0012430	ETX7L-BS	YTX7L-BS
		SB6R	1100	97-99	RHTX12-BS	0012320	ETX12-BS	YTX12-BS
SB8R, SB8RS		996	98-00	RHTX12-BS	0012320	ETX12-BS	YTX12-BS	
YB10 Dieci		1000	-	RHTX14-BS	0012390	ETX14-BS	YTX14-BS	
BMW	YB11	1000	96-99	RHTX12-BS	0012320	ETX12-BS	YTX12-BS	
	100 RS	1000	76-84	RH60-N30L-AHD	0012730		53030	
	BMW K1	1000	-	RH60-N24AL-B				
	C600 Sport	600	11-	RHTZ12S-BS				
	C650 GT	650	12-	RHTZ12S-BS		ELTZ14S	YTZ12-S	
	F650	600	93-01	RHB12AL-A	0012340	EB12AL-A	YB12AL-A	
	F650, S	650	93-	RH60-N24AL-B				
	F650, S	650	93-01	RHB12AL-A	0012340	EB12AL-A	YB12AL-A	
	F650,S	600	98-02	RHB12AL-A	0012340	EB12AL-A	YB12AL-A	
	F650CS/GS/ST	650	98-02	RHB12AL-A	0012340	EB12AL-A	YB12AL-A	
	F650GS	650	08-11	RHTX14-BS	0012390	ETX14-BS	YTX14-BS	
	F650GS	800	09-10	RHTX14-BS	0012390	ETX14-BS	YTX14-BS	
	F700 GS	700	13-	RHTX14-BS	0012390	ETX14-BS	YTX14-BS	
	F700 GS	800	11-	RHTZ12S-BS		ELTZ14S	YTZ12-S	
	F700 GS (auxiliary battery)	700	13-	RHTZ14S-BS	0012580		YTZ14S-BS	
	F800ST, GS, GT	800	09-	RHTX14-BS	0012390	ETX14-BS	YTX14-BS	

BATTERIE MOTO - ATV, UTV - MARINE

MARCA	MODELLO	CC	ANNO	BATTERIA RHIAG	BATTERIA MPT	BATTERIA EXIDE	BATTERIA YUASA
MAKE	MODEL	CC	YEAR	RHIAG BATTERY	MOTORPARTS BATTERY	EXIDE BATTERY	YUASA BATTERY
BMW	G450X	450	09-	RHTZ75-BS	0012500		YTZ75-BS
	HP2 Sport / Megamoto	1200	09-10	RHTX14-BS	0012390	ETX14-BS	YTX14-BS
	HP4	1000	12-	RHTZ75-BS	0012500		YTZ75-BS
	hp4 (with alarm system)	1000	12-	RHTZ10S-BS	0012540		YTZ10S-BS
	K100, K100RS, -RT	1000	-	RH60-N30L-AHD	0012730		53030
	K1100- RS	1100	99-05	RHP18-12	0012560		52015
	K1100-LT	1100	99-05	RHP18-12	0012560		52015
	K1200 GT	1200	99-05	RHP18-12	0012560		52015
	K1200 R/Cruiser	1200	-	RH60-N30L-AHD	0012730		53030
	K1200 RS	1200	99-05	RHP18-12	0012560		52015
	K1200LT, GT	1200	05-10	RHP18-12	0012560		52015
	K1200R,S	1200	05-09	RHTX14-BS	0012390	ETX14-BS	YTX14-BS
	K1200R,S	1200	99-05	RHP18-12	0012560		52015
	K1300GT	1300	09-10	RHP18-12	0012560		52015
	K1300R, S	1300	09-14	RHTX14-BS	0012390	ETX14-BS	YTX14-BS
	K1300S HP	1300	12-	RHTX14-BS	0012390	ETX14-BS	YTX14-BS
	K1600 GT	1600	10-	RHP18-12	0012560		52015
	K1600 GTL	1600	10-	RHP18-12	0012560		52015
	K75, Modelli RT	750	85-95	RH60-N30L-AHD	0012730		53030
	Modelli R	1000	77-94	RH60-N30L-AHD	0012730		53030
	R100 CS, RS, RT, R, S,T	1000	-84	RH60-N30L-AHD	0012730		53030
	R100 GS, PD	1000	87-95	RH60-N30L-AHD	0012730		53030
	R100/7, -CS, -RS, -RT, -S	1000	-84	RH60-N30L-AHD	0012730		53030
	R100R	1000	00-	RHP18-12	0012560		52015
	R100RT, R100RS	1000	85-	RH60-N30L-AHD	0012730		53030
	R1100R, GS, LT, RS, RT	1100	-	RHP18-12	0012560		52015
	R1100R, LT,RS,RT	1100	94-01	RHP18-12	0012560		52015
	R1100S	1100	99-02	RHP18-12	0012560		52015
	R1150 GS	1150	00-	RHP18-12	0012560		52015
	R1150R/RS/RT	1150	01-02	RHP18-12	0012560		52015
	R1200C	1200	98-05	RHP18-12	0012560		52015
	R1200GS Adventure	1200	09-	RHTZ14S-BS	0012580		YTZ14S-BS
	R1200GS Adventure successor	1200	09-	RHTZ14S-BS	0012580		YTZ14S-BS
	R1200GS successor	1200	09-	RHTZ14S-BS	0012580		YTZ14S-BS
	R1200GS, S, R	1200	05-	RHTX14-BS	0012390	ETX14-BS	YTX14-BS
	R1200R successor	1200	09-	RHTZ14S-BS	0012580		YTZ14S-BS
	R1200RT	1200	05-10	RHP18-12	0012560		52015
	R60/6, R60/7	600	69-84	RH60-N30L-AHD	0012730		53030
	R65	650	85-95	RH60-N30L-AHD	0012730		53030
	R650CS	650	02-	RHB12AL-A	0012340	EB12AL-A	YB12AL-A
	R75-6	750	00-	RH60-N30L-AHD	0012730		53030
	R75/6	750	69-76	RH60-N30L-AHD	0012730		53030
	R75/7	750	69-84	RH60-N30L-AHD	0012730		53030
	R80, R80RT	800	84-95	RH60-N30L-AHD	0012730		53030
	R80, R80RT	800	85-	RH60-N24AL-B			
	R80/7, R80RT	800	78-84	RH60-N30L-AHD	0012730		53030
	R80ET	800	00-	RH60-N30L-AHD	0012730		53030
R80GS	800	88-	RH60-N24AL-B				
R850R/RT/GS, R259	850	-	RHP18-12	0012560		52015	
R85C	850	99-01	RHP18-12	0012560		52015	
R90/6, R90S	900	69-76	RH60-N30L-AHD	0012730		53030	

MARCA	MODELLO	CC	ANNO	BATTERIA RHIAG	BATTERIA MPT	BATTERIA EXIDE	BATTERIA YUASA	
MAKE	MODEL	CC	YEAR	RHIAG BATTERY	MOTORPARTS BATTERY	EXIDE BATTERY	YUASA BATTERY	
BMW	R90/6, R90S	900	77-84	RH60-N24AL-B				
	S1000RR	1000	09-	RHTX10S-BS	0012540		YTZ10S-BS	
	S1000RR (DWA)	1000	09-	RHTX12S-BS		ELTZ14S	YTZ12-S	
	Auto-Motorcycle		-	RHTX20L-BS	0012640		YTX20L-BS	
	Fat Daddy, Fatso		-	RHTX20L-BS	0012640		YTX20L-BS	
	Joker, Black Jack Ace, Kruser		-	RHTX20L-BS	0012640		YTX20L-BS	
	Low-Blow, Beach Cruiser		-	RHTX20L-BS	0012640		YTX20L-BS	
	Retro Chopper, Magnum		-	RHTX20L-BS	0012640		YTX20L-BS	
BSV	GP Dio, Sp Dio	50	-	RHTX4L-BS	0012310	ETX4L-BS	YTX4L-BS	
	GZ	50	-	RHTX4L-BS	0012310	ETX4L-BS	YTX4L-BS	
	R 100 S	100	77-79	RH60-N24AL-B				
	R 100 S	100	79-81	RH60-N30L-AHD	0012730		53030	
	R 100 T	100	78-81	RH60-N30L-AHD	0012730		53030	
BUELL	ZX	50	94-95	RHTX4L-BS	0012310	ETX4L-BS	YTX4L-BS	
	Blast	500	00-	RHTX14-BS	0012390	ETX14-BS	YTX14-BS	
	Buell Racing 1125RR	1125	09	RHTZ7S-BS	0012500		YTZ7S-BS	
	M2 Cyclone	1200	97-02	RHTX20L-BS	0012640		YTX20L-BS	
	S1 Lightning, WL White	1200	96-99	RHTX14-BS	0012390	ETX14-BS	YTX14-BS	
	S3, S3T Thunderbolt	1200	97-02	RHTX20L-BS	0012640		YTX20L-BS	
	X1 Lighting	1200	99-00	RHTX20L-BS	0012640		YTX20L-BS	
	XB 12S Lightning	1200	04-10	RHTX14-BS	0012390	ETX14-BS	YTX14-BS	
	XB12R Firebolt	1200	04-10	RHTX14-BS	0012390	ETX14-BS	YTX14-BS	
	XB12Ss, Scg, Lightning	1200	04-10	RHTX14-BS	0012390	ETX14-BS	YTX14-BS	
	XB12X XT Ulysses	1200	06-10	RHTX14-BS	0012390	ETX14-BS	YTX14-BS	
	XB9R Firebolt	984	02-10	RHTX14-BS	0012390	ETX14-BS	YTX14-BS	
	XB9S Lightning	984	02-10	RHTX14-BS	0012390	ETX14-BS	YTX14-BS	
	CAGIVA	Canyon, River	500	95-99	RHTX14-BS	0012390	ETX14-BS	YTX14-BS
		City, Lucky, Explorer	50	94-97	RHTX4L-BS	0012310	ETX4L-BS	YTX4L-BS
Cocis, Prima, Mantis, Supercity		50	-	RHB4L-B	0012180	EB4L-B	YB4L-B	
Crouser, CUCC 125		125	87-88	RHB9-B		EB9-B	YB9-B	
cucciolo		50	98-99	RHTX4L-BS	0012310	ETX4L-BS	YTX4L-BS	
Cucciolo		125	00	RHB9-B		EB9-B	YB9-B	
Cucciolo, Mito		50	98	RHTX4L-BS	0012310	ETX4L-BS	YTX4L-BS	
EV		125	-	RHB9-B		EB9-B	YB9-B	
Freccia C9, /C10R, /C12R		125	87-90	RHB9-B		EB9-B	YB9-B	
GT Progress, Corsa 50		50	98	RHB4L-B	0012180	EB4L-B	YB4L-B	
K 7 Passing		125	-	RHB4L-B	0012180	EB4L-B	YB4L-B	
K3, W4		50	-98	RHB4L-B	0012180	EB4L-B	YB4L-B	
Mito		50	98-99	RHB4L-B	0012180	EB4L-B	YB4L-B	
Mito SP525		125	08	RHB9-B		EB9-B	YB9-B	
Mito, - 2, Replica, Ev.		125	-98	RHB9-B		EB9-B	YB9-B	
Mito, Racing, Lawson		125	94-08	RHB9-B		EB9-B	YB9-B	
Mitto 125, R		125	94-97	RHB9-B		EB9-B	YB9-B	
Muntis 50		50	99	RHB4L-B	0012180	EB4L-B	YB4L-B	
N 90		125	97	RHB9-B		EB9-B	YB9-B	
Navigator		1000	-	RHT12B-BS	0012550	ET12B-BS	YT12B-BS	
Navigator	1000	00-05	RHP18-12	0012560		52015		
Passing	125	93-97	RHB9-B		EB9-B	YB9-B		
Planet	125	98-03	RHB9-B		EB9-B	YB9-B		
Progress/Lc	50	97-98	RHTX4L-BS	0012310	ETX4L-BS	YTX4L-BS		
Raptor	125	04-07	RHB9-B		EB9-B	YB9-B		

BATTERIE MOTO - ATV, UTV - MARINE

MARCA MAKE	MODELLO MODEL	CC CC	ANNO YEAR	BATTERIA RHIAG RHIAG BATTERY	BATTERIA MPT MOTORPARTS BATTERY	BATTERIA EXIDE EXIDE BATTERY	BATTERIA YUASA YUASA BATTERY
CAGIVA	Raptor (all models)	650	01	RHTX9-BS	0012330	ETX9-BS	YTX9-BS
	Raptor (all models)	1000	00	RHT12A-BS	0012470	ET12A-BS	YT12A-BS
	Roadstar	200	95	RHB9-B		EB9-B	YB9-B
	Roadster	50	94-97	RHB9-B		EB9-B	YB9-B
	Roadster	125	94-99	RHB9-B		EB9-B	YB9-B
	SM125	50	00-	RHTX4L-BS/RHTX5L-BS	0012310/0012380	ETX4L-BS/ETX5L-BS	YTX4L-BS/YTX5L-BS
	SM125	125	00	RHTX5L-BS	0012380	ETX5L-BS	YTX5L-BS
	Supercity	50	91-97	RHB9-B		EB9-B	YB9-B
	Supercity	125	91-99	RHB9-B		EB9-B	YB9-B
	Tamanaco	125	-	RHB9-B		EB9-B	YB9-B
	V-Raptor	650	00	RHB9-B		EB9-B	YB9-B
	V-Raptor	650	01-06	RHTX9-BS	0012330	ETX9-BS	YTX9-BS
	W 8	50	-	RHB4L-B	0012180	EB4L-B	YB4L-B
	W16	500	94-98	RHTX14-BS	0012390	ETX14-BS	YTX14-BS
	W4 6V	50	92-95	RHB4L-B	0012180	EB4L-B	YB4L-B
	W8	125	93-98	RHB4L-B	0012180	EB4L-B	YB4L-B
	Wre	125	00	RHTX5L-BS	0012380	ETX5L-BS	YTX5L-BS
	Wre125	50	00-	RHTX4L-BS/RHTX5L-BS	0012310/0012380	ETX4L-BS/ETX5L-BS	YTX4L-BS/YTX5L-BS
	CANNONDALE	C440, E440, S440, X440, X440S	440	02-03	RHTZ7S-BS	0012500	
EX400, MX400, XC400		400	00-01	RHTZ7S-BS/RHTX5L-BS	0012380	ETX5L-BS	YTX5L-BS
DAELIM	Fellow	125	97	RHB9-B		EB9-B	YB9-B
	Message, Tapo	50	-	RHTX4L-BS	0012310	ETX4L-BS	YTX4L-BS
	MS125, Othello 125	125	-	RHTX7A-BS	0012350	ETX7A-BS	YTX7A-BS
	NS125	125	97-	RHTX7A-BS	0012350	ETX7A-BS	YTX7A-BS
	Reiju	125	-	RHB4L-B	0012180	EB4L-B	YB4L-B
	S1 125	125	10-	RHTX12-BS	0012320	ETX12-BS	YTX12-BS
	S3 125	125	10-	RHTX12-BS	0012320	ETX12-BS	YTX12-BS
	VC125, VC125F, VL125	125	96	RHB9-B		EB9-B	YB9-B
	VS125, VX125, VT, Evolution; Day Start	125	97	RHB9-B		EB9-B	YB9-B
	VT 125 Magna	125	97	RHB9-B		EB9-B	YB9-B
DAZON	Diamandback	50	03-04	RHTX4L-BS	0012310	ETX4L-BS	YTX4L-BS
	Raider-Classic (Kart)	150	04	RHTX9-BS	0012330	ETX9-BS	YTX9-BS
	Raider-Classic (Kart)	250	-	RHTX9-BS	0012330	ETX9-BS	YTX9-BS
	Raider-Max (Kart)	150	04	RHTX9-BS	0012330	ETX9-BS	YTX9-BS
	Raider-Max (Kart)	250	-	RHTX9-BS	0012330	ETX9-BS	YTX9-BS
	Scorpion	125	04	RHTX9-BS	0012330	ETX9-BS	YTX9-BS
DERBI	Sicilian	125	04	RHTX7A-BS	0012350	ETX7A-BS	YTX7A-BS
	Atlantis	50	99-07	RHB4L-B	0012180	EB4L-B	YB4L-B
	Atlantis	100	-	RHTX7L-BS	0012430	ETX7L-BS	YTX7L-BS
	Aventura, Furax, Hunter	50	96-97	RHB4L-B	0012180	EB4L-B	YB4L-B
	Boulevard	125	02-07	RHTX7L-BS	0012430	ETX7L-BS	YTX7L-BS
	Boulevard	150	02-07	RHTX9-BS	0012330	ETX9-BS	YTX9-BS
	Boulevard	200	05	RHTX9-BS	0012330	ETX9-BS	YTX9-BS
	Cross City Eu3	125	07-08	RHTX7L-BS	0012430	ETX7L-BS	YTX7L-BS
	Easy 50	50	97	RHB4L-B	0012180	EB4L-B	YB4L-B
	Fenix	50	94	RHB4L-B	0012180	EB4L-B	YB4L-B
	Furax	50	96	RHB4L-B	0012180	EB4L-B	YB4L-B
	Gp1	50	01-03	RHB4L-B	0012180	EB4L-B	YB4L-B
GP1	125	04-08	RHTX7L-BS	0012430	ETX7L-BS	YTX7L-BS	
GP1	250	06-08	RHTX9-BS	0012330	ETX9-BS	YTX9-BS	
Gp1 Eu2, Race	50	05-07	RHB4L-B	0012180	EB4L-B	YB4L-B	

MARCA MAKE	MODELLO MODEL	CC CC	ANNO YEAR	BATTERIA RHIAG RHIAG BATTERY	BATTERIA MPT MOTORPARTS BATTERY	BATTERIA EXIDE EXIDE BATTERY	BATTERIA YUASA YUASA BATTERY	
DERBI	Gp1 Open	50	06-08	RHB4L-B	0012180	EB4L-B	YB4L-B	
	GPR	125	04-06	RHTX7L-BS	0012430	ETX7L-BS	YTX7L-BS	
	GPR 50 Racing	50	11-	RHB4L-B	0012180	EB4L-B	YB4L-B	
	Gpr Nude, Touning, Sport	50	99-07	RHB4L-B	0012180	EB4L-B	YB4L-B	
	Gpr R	50	97-00	RHB4L-B	0012180	EB4L-B	YB4L-B	
	Gpr Racing, E2, R E2,	50	04-06	RHB4L-B	0012180	EB4L-B	YB4L-B	
	Gpr Replica,	50	05-07	RHB4L-B	0012180	EB4L-B	YB4L-B	
	Gpr Replica,	50	99-03	RHB4L-B	0012180	EB4L-B	YB4L-B	
	Hunter	50	96-97	RHB4L-B	0012180	EB4L-B	YB4L-B	
	Mulhacen	125	12	RHTX7L-BS	0012430	ETX7L-BS	YTX7L-BS	
	Mulhacen	125	07-08	RHTX7L-BS	0012430	ETX7L-BS	YTX7L-BS	
	Paddock	50	97-99	RHB4L-B	0012180	EB4L-B	YB4L-B	
	Predator, LC, 02	50	98-01	RHB4L-B	0012180	EB4L-B	YB4L-B	
	Rambla	125	08	RHTX7L-BS	0012430	ETX7L-BS	YTX7L-BS	
	Rambla	250	08	RHTX9-BS	0012330	ETX9-BS	YTX9-BS	
	Senda	125	04-08	RHTX7L-BS	0012430	ETX7L-BS	YTX7L-BS	
	Senda Baja 125 SM	125	12	RHTX7L-BS	0012430	ETX7L-BS	YTX7L-BS	
	Senda DRD 125 R	125	12	RHTX7L-BS	0012430	ETX7L-BS	YTX7L-BS	
	Senda DRD 125 SM	125	12	RHTX7L-BS	0012430	ETX7L-BS	YTX7L-BS	
	Senda DRD Pro 50 R	50	11-	RHB4L-B	0012180	EB4L-B	YB4L-B	
	Senda DRD Racing 50 R	50	11-	RHB4L-B	0012180	EB4L-B	YB4L-B	
	Senda DRD Racing 50 SM	50	11-	RHB4L-B	0012180	EB4L-B	YB4L-B	
	Senda DRD X-Treme 50 R	50	11-	RHB4L-B	0012180	EB4L-B	YB4L-B	
	Senda DRD X-Treme 50 SM	50	11-	RHB4L-B	0012180	EB4L-B	YB4L-B	
	Senda-L, Senda-R	50	94-	RHB4L-B	0012180	EB4L-B	YB4L-B	
	Sport	50	97	RHB4L-B	0012180	EB4L-B	YB4L-B	
	Terra	125	07-08	RHTX7L-BS	0012430	ETX7L-BS	YTX7L-BS	
	Terra 125	125	11	RHTX7L-BS	0012430	ETX7L-BS	YTX7L-BS	
	Vamos	50	93-	RHB4L-B	0012180	EB4L-B	YB4L-B	
	Variant- GS	50	97	RHB4L-B	0012180	EB4L-B	YB4L-B	
	DUCATI	749	749	03-06	RHT12B-BS	0012550	ET12B-BS	YT12B-BS
		848	848	08	RHT12B-BS	0012550	ET12B-BS	YT12B-BS
996		996	99-00	RHB16AL-A2				
1098		1098	07	RHTX14-BS	0012390	ETX14-BS	YTX14-BS	
1098		1100	07-	RHT12B-BS	0012550	ET12B-BS	YT12B-BS	
1098 S		1098	07-09	RHT12B-BS	0012550	ET12B-BS	YT12B-BS	
1198 MY08, SP, R		1198	10-	RHT12B-BS	0012550	ET12B-BS	YT12B-BS	
1199 Panigale, S		1199	12	RHT7B-BS	0012520	ET7B-BS	YT7B-BS	
125 Multistrada		1200	07	RHT12B-BS	0012550	ET12B-BS	YT12B-BS	
696 Monster		696	09-10	RHT12B-BS	0012550	ET12B-BS	YT12B-BS	
998, 999		998	02-07	RHT12B-BS	0012550	ET12B-BS	YT12B-BS	
999 Biposto, S,R		999	03-	RHT12B-BS	0012550	ET12B-BS	YT12B-BS	
Biposto, Senna, Strada		916	94-	RHB16AL-A2				
Biposto/SP2/SPORT		851	89-90	RHB16AL-A2				
Desmosedici RR		1000	08	RHT12B-BS	0012550	ET12B-BS	YT12B-BS	
Diavel		1200	11-	RHT12B-BS	0012550	ET12B-BS	YT12B-BS	
Elefant		900	95	RHB16AL-A2				
GT Europe		1000	07-	RHT12B-BS	0012550	ET12B-BS	YT12B-BS	
GT, Laguna Seca		750	-	RH60-N30L-AHD	0012730		53030	
GT,GTS (Electric Start)		860	-	RH60-N30L-AHD	0012730		53030	
GT1000, Touring		1000	09	RHT12B-BS	0012550	ET12B-BS	YT12B-BS	

BATTERIE MOTO - ATV, UTV - MARINE

MARCA MAKE	MODELLO MODEL	CC CC	ANNO YEAR	BATTERIA RHIAG RHIAG BATTERY	BATTERIA MPT MOTORPARTS BATTERY	BATTERIA EXIDE EXIDE BATTERY	BATTERIA YUASA YUASA BATTERY
DUCATI	Hypermotard	1100	08-	RHT12B-BS	0012550	ET12B-BS	YT12B-BS
	Hypermotard Evo SP	1078	10-	RHT12B-BS	0012550	ET12B-BS	YT12B-BS
	I.E, SP, SP S	916	94-	RHB16AL-A2			
	LTD	888	94	RHB16AL-A2			
	M Chromo	600	98	RHB16AL-A2			
	M Chromo	900	01	RHT12B-BS	0012550	ET12B-BS	YT12B-BS
	M Chromo	900	98-00	RHB16AL-A2			
	M City/M Dark/M Dark City	600	98-00	RHB16AL-A2			
	M City/M Dark/M Dark City	750	99-00	RHB16AL-A2			
	M City/M Dark/M Dark City	900	99-00	RHB16AL-A2			
	M Dark	600	01	RHT12B-BS	0012550	ET12B-BS	YT12B-BS
	M Dark	750	01	RHT12B-BS	0012550	ET12B-BS	YT12B-BS
	M Dark	900	01	RHT12B-BS	0012550	ET12B-BS	YT12B-BS
	M IE/ M IE Dark	750	02	RHT12B-BS	0012550	ET12B-BS	YT12B-BS
	M IE/ M IE Dark2	900	02	RHT12B-BS	0012550	ET12B-BS	YT12B-BS
	M Metallic	900	00	RHB16AL-A2			
	M Metallic/M S	900	01	RHT12B-BS	0012550	ET12B-BS	YT12B-BS
	M Special	900	98-00	RHB16AL-A2			
	M900	900	94	RHB16AL-A2			
	Monoposto, Biposto	998	01-	RHT12B-BS	0012550	ET12B-BS	YT12B-BS
	Monster	400	01	RHT12B-BS	0012550	ET12B-BS	YT12B-BS
	Monster	400	02-04	RHT12B-BS	0012550	ET12B-BS	YT12B-BS
	Monster	400	95-00	RHB16AL-A2			
	Monster	600	01-07	RHT12B-BS	0012550	ET12B-BS	YT12B-BS
	Monster	600	93-00	RHB16AL-A2			
	Monster	620	-	RHT12B-BS	0012550	ET12B-BS	YT12B-BS
	Monster	750	-99	RHB16AL-A2			
	Monster	750	00-	RHT12B-BS	0012550	ET12B-BS	YT12B-BS
	Monster	800	03-04	RHT12B-BS	0012550	ET12B-BS	YT12B-BS
	Monster	800	10-	RHT12B-BS	0012550	ET12B-BS	YT12B-BS
	Monster	900	01-07	RHT12B-BS	0012550	ET12B-BS	YT12B-BS
	Monster	900	00-	RHB16AL-A2			
	Monster , Superlight	900	-99	RHB16AL-A2			
	Monster 1100	1100	09-10	RHT12B-BS	0012550	ET12B-BS	YT12B-BS
	Monster 695/696	700	07-08	RHT12B-BS	0012550	ET12B-BS	YT12B-BS
	Monster Dk, Ie	400	05-08	RHT12B-BS	0012550	ET12B-BS	YT12B-BS
	Monster S	800	03-	RHT12B-BS	0012550	ET12B-BS	YT12B-BS
	Monster S/S2R/S4RS	1000	03-08	RHT12B-BS	0012550	ET12B-BS	YT12B-BS
	Monster S2R	800	04	RHT12B-BS	0012550	ET12B-BS	YT12B-BS
	Monster S4	916	01-07	RHT12B-BS	0012550	ET12B-BS	YT12B-BS
	Monster S4	916	99-00	RHB16AL-A2			
	Monster S4R	996	03-06	RHT12B-BS	0012550	ET12B-BS	YT12B-BS
	Monster/IE/S IE/Sport	620	02-03	RHT12B-BS	0012550	ET12B-BS	YT12B-BS
	Motoposto, Biposto, S	996	01-	RHT12B-BS	0012550	ET12B-BS	YT12B-BS
	Multistrada	620	06	RHT12B-BS	0012550	ET12B-BS	YT12B-BS
	Multistrada	650	07	RHT12B-BS	0012550	ET12B-BS	YT12B-BS
	Multistrada	1000	03-06	RHT12B-BS	0012550	ET12B-BS	YT12B-BS
Multistrada	1100	07-	RHT12B-BS	0012550	ET12B-BS	YT12B-BS	
Multistrada, Multistrada Pikes Peak	1200	12-	RHT12B-BS	0012550	ET12B-BS	YT12B-BS	
New Monster	750	-	RHT12B-BS	0012550	ET12B-BS	YT12B-BS	
Panigale 1199	1199	11-	RHT7B-BS	0012520	ET7B-BS	YT7B-BS	

MARCA MAKE	MODELLO MODEL	CC CC	ANNO YEAR	BATTERIA RHIAG RHIAG BATTERY	BATTERIA MPT MOTORPARTS BATTERY	BATTERIA EXIDE EXIDE BATTERY	BATTERIA YUASA YUASA BATTERY
DUCATI	Paul Smart L.E.	1000	06-	RHT12B-BS	0012550	ET12B-BS	YT12B-BS
	Police	900	95	RHB16AL-A2			
	Rs	999	04-05	RHT12B-BS	0012550	ET12B-BS	YT12B-BS
	S R	748	01-	RHT12B-BS	0012550	ET12B-BS	YT12B-BS
	S. Hypermotard	1100	07-	RHT12B-BS	0012550	ET12B-BS	YT12B-BS
	SL	900	92-96	RHB16AL-A2			
	SP, SP II, SP IV, SP V	888	90-95	RHB16AL-A2			
	Sport	620	03	RHT12B-BS	0012550	ET12B-BS	YT12B-BS
	Sport	750	01	RHT12B-BS	0012550	ET12B-BS	YT12B-BS
	Sport	750	02	RHT12B-BS	0012550	ET12B-BS	YT12B-BS
	Sport	750	89-90	RHB16AL-A2			
	Sport	750	97-00	RHB16AL-A2			
	Sport	800	03	RHT12B-BS	0012550	ET12B-BS	YT12B-BS
	Sport	900	99	RHT12B-BS	0012550	ET12B-BS	YT12B-BS
	Sport 1000	1000	06-	RHT12B-BS	0012550	ET12B-BS	YT12B-BS
	Sport S Biposto, GT ST3	1000	01-07	RHT12B-BS	0012550	ET12B-BS	YT12B-BS
	Sport Touring 2	944	-	RHB16AL-A2			
	Sport Touring 4	916	-	RHT12B-BS	0012550	ET12B-BS	YT12B-BS
	Sport Touring 4S	996	01-	RHT12B-BS	0012550	ET12B-BS	YT12B-BS
	SPS, R	996	00-	RHT12B-BS	0012550	ET12B-BS	YT12B-BS
	SR	748	01-02	RHT12B-BS	0012550	ET12B-BS	YT12B-BS
	SS	750	01-02	RHT12B-BS	0012550	ET12B-BS	YT12B-BS
	SS	750	90-00	RHB16AL-A2			
	SS	800	07	RHT12B-BS	0012550	ET12B-BS	YT12B-BS
	SS	900	01-07	RHT12B-BS	0012550	ET12B-BS	YT12B-BS
	SS	900	89-99	RHB16AL-A2			
	SS IE	750	00	RHB16AL-A2			
	SS IE	750	01-02	RHT12B-BS	0012550	ET12B-BS	YT12B-BS
	SS IE	900	00	RHB16AL-A2			
	SS IE	900	01-02	RHT12B-BS	0012550	ET12B-BS	YT12B-BS
	SS Supersport	350	93-	RHB16AL-A2			
	SS Supersport	400	91-99	RHB16AL-A2			
	SS Supersport	600	91-99	RHB16AL-A2			
	SS Veloce	750	98	RHB16AL-A2			
	ST 2	944	01-	RHT12B-BS	0012550	ET12B-BS	YT12B-BS
	ST 2	944	97-00	RHB16AL-A2			
	ST2	1000	-	RHB16AL-A2			
	ST3	992	-	RHT12B-BS	0012550	ET12B-BS	YT12B-BS
	ST3	1000	04-07	RHT12B-BS	0012550	ET12B-BS	YT12B-BS
	ST4	916	01-	RHT12B-BS	0012550	ET12B-BS	YT12B-BS
	ST4	916	99-00	RHB16AL-A2			
	ST4	1000	-	RHB16AL-A2			
	ST4S	996	01-	RHT12B-BS	0012550	ET12B-BS	YT12B-BS
	Strada	888	91-94	RHB16AL-A2			
	Strada Biposto, SP, SPS	748	01-02	RHT12B-BS	0012550	ET12B-BS	YT12B-BS
	Strada Biposto, SP, SPS	748	97-00	RHB16AL-A2			
	Strada Biposto, SP, SPS	748	97-00	RHB16AL-A2			
	Street Fighter, S	1100	09	RHT12B-BS	0012550	ET12B-BS	YT12B-BS
	Streetfighter 848	848	11-	RHT12B-BS	0012550	ET12B-BS	YT12B-BS
	Superbike	851	90-91	RHB16AL-A2			
Superbike 1098, S, Tricolore	1098	-07	RHT12B-BS	0012550	ET12B-BS	YT12B-BS	

BATTERIE MOTO - ATV, UTV - MARINE

MARCA MAKE	MODELLO MODEL	CC CC	ANNO YEAR	BATTERIA RHIAG RHIAG BATTERY	BATTERIA MPT MOTORPARTS BATTERY	BATTERIA EXIDE EXIDE BATTERY	BATTERIA YUASA YUASA BATTERY	
DUCATI	Superbike 749R, S	749	-	RHT12B-BS	0012550	ET12B-BS	YT12B-BS	
	Superbike, Strada	851	91-92	RHB16AL-A2				
	Supersport	800	03-07	RHT12B-BS	0012550	ET12B-BS	YT12B-BS	
	Supersport 900	904	99	RHB16AL-A2				
	Supersport FE, IE	900	-99	RHB16AL-A2				
	Supersport HF	1000	03	RHT12B-BS	0012550	ET12B-BS	YT12B-BS	
	Supersport HF	1000	03-	RHT12B-BS	0012550	ET12B-BS	YT12B-BS	
	Supersport IE	900	01-02	RHT12B-BS	0012550	ET12B-BS	YT12B-BS	
	Tutti gli altri modelli / All other models	1098	01-10	RHT12B-BS	0012550	ET12B-BS	YT12B-BS	
ETON	Twin	500	-	RH60-N30L-AHD	0012730		53030	
	Beamer 150	150	-11	RHTX9-BS	0012330	ETX9-BS	YTX9-BS	
	Beamer R4-150	150	10	RHTX9-BS	0012330	ETX9-BS	YTX9-BS	
	Beamer50, Beamer III	50	00-10	RHTX5L-BS/RHTZ75-BS	0012380	ETX5L-BS	YTX5L-BS	
	Matrix 50	50	-11	RHTX5L-BS/RHTZ75-BS	0012380	ETX5L-BS	YTX5L-BS	
	Matrix R4-150	150	-11	RHTX9-BS	0012330	ETX9-BS	YTX9-BS	
	Sport 150	150	-11	RHTX7A-BS	0012350	ETX7A-BS	YTX7A-BS	
	Sport 50	50	-11	RHTX7A-BS	0012350	ETX7A-BS	YTX7A-BS	
	Grinta	50	95-96	RHTX4L-BS	0012310	ETX4L-BS	YTX4L-BS	
FANTIC	GTA (Electric-Start)	125	-	RHB9-B		EB9-B	YB9-B	
	GTA (Kick-Start)	125	-	RHB5L-B	0012240	EB5L-B	YB5L-B	
	HP 1	50	-	RHB4L-B	0012180	EB4L-B	YB4L-B	
	Koala	50	93-97	RHB4L-B	0012180	EB4L-B	YB4L-B	
	Koala	80	93-96	RHB4L-B	0012180	EB4L-B	YB4L-B	
	Leader	50	95	RHTX4L-BS	0012310	ETX4L-BS	YTX4L-BS	
	NOi (Electric-Start)	50	-	RHB4L-B	0012180	EB4L-B	YB4L-B	
	Oasis	50	-	RHB4L-B	0012180	EB4L-B	YB4L-B	
	Pony, SR	50	95	RHB4L-B	0012180	EB4L-B	YB4L-B	
	Queenie	50	95	RHTX4L-BS	0012310	ETX4L-BS	YTX4L-BS	
	XR125 Tiger	125	-	RHB5L-B	0012240	EB5L-B	YB5L-B	
	GARELLI	Big Racing	50	94	RHB4L-B	0012180	EB4L-B	YB4L-B
		Big Wheel	50	10-	RHB4L-B	0012180	EB4L-B	YB4L-B
		Big Wheel	50	94-95	RHB4L-B	0012180	EB4L-B	YB4L-B
		Capri	50	06	RHTX4L-BS	0012310	ETX4L-BS	YTX4L-BS
Capri LX		50	07-08	RHTX4L-BS	0012310	ETX4L-BS	YTX4L-BS	
Ciclone		50	06	RHTX4L-BS	0012310	ETX4L-BS	YTX4L-BS	
Comfort		125	07-08	RHTX7L-BS	0012430	ETX7L-BS	YTX7L-BS	
Grinta		50	95-96	RHTX4L-BS	0012310	ETX4L-BS	YTX4L-BS	
GTA El.- Starter		125	-	RHB9-B		EB9-B	YB9-B	
GTA Kick-Starter		125	-	RHB5L-B	0012240	EB5L-B	YB5L-B	
King		150	07-08	RHTX9-BS	0012330	ETX9-BS	YTX9-BS	
King		150	10-	RHTX7L-BS	0012430	ETX7L-BS	YTX7L-BS	
Noi		50	-	RHB4L-B	0012180	EB4L-B	YB4L-B	
Pony, Pony SR		50	94-95	RHB4L-B	0012180	EB4L-B	YB4L-B	
Queenie		50	95	RHTX4L-BS	0012310	ETX4L-BS	YTX4L-BS	
Queenie		50	10-	RHTX4L-BS	0012310	ETX4L-BS	YTX4L-BS	
Sahel, Team, Urka		50	10-	RHB4L-B	0012180	EB4L-B	YB4L-B	
Tiger		125	10-	RHTX7L-BS	0012430	ETX7L-BS	YTX7L-BS	
Vip		50	06	RHTX4L-BS	0012310	ETX4L-BS	YTX4L-BS	
VIP		50	10-	RHB4L-B	0012180	EB4L-B	YB4L-B	
XLE Tiger		50	-	RHB4L-B	0012180	EB4L-B	YB4L-B	
Xo	125	10-	RHTX9-BS	0012330	ETX9-BS	YTX9-BS		

MARCA	MODELLO	CC	ANNO	BATTERIA RHIAG	BATTERIA MPT	BATTERIA EXIDE	BATTERIA YUASA
MAKE	MODEL	CC	YEAR	RHIAG BATTERY	MOTORPARTS BATTERY	EXIDE BATTERY	YUASA BATTERY
GARELLI	XR Tiger El. Starter	125	-	RHB9-B		EB9-B	YB9-B
	XR Tiger Kick-Starter	125	-	RHB5L-B	0012240	EB5L-B	YB5L-B
GAS GAS	FSR 450	450	08	RHTZ7S-BS	0012500		YTZ7S-BS
	Pampera	250	96-01	RHTX4L-BS	0012310	ETX4L-BS	YTX4L-BS
GILERA	Pampera	320	98-01	RHTX4L-BS	0012310	ETX4L-BS	YTX4L-BS
	Pampera	370	97	RHTX4L-BS	0012310	ETX4L-BS	YTX4L-BS
	503	50	-	RHB4L-B	0012180	EB4L-B	YB4L-B
	125DNA	125	01	RHB10L-B-P	0012480	EB10L-B	YB10L-B
	Apache El. -Starter	125	-	RHB9-B		EB9-B	YB9-B
	Apache Kick-Starter	125	-	RHB9-B		EB9-B	YB9-B
	Arizona El. -Starter	125	-	RHB9-B		EB9-B	YB9-B
	Arizona El. -Starter	200	-	RHB9-B		EB9-B	YB9-B
	Arizona Kick-Starter	125	-	RHB9-B		EB9-B	YB9-B
	Arizona Rally	250	-	RHB10L-B-P	0012480	EB10L-B	YB10L-B
	Bullit, Easy Moving, Runner	50	-97	RHB4L-B	0012180	EB4L-B	YB4L-B
	Coguar	125	-	RHB9-B		EB9-B	YB9-B
	Coguar	125	99-01	RHB9-B		EB9-B	YB9-B
	Crono El. -Starter	125	-	RHB9-B		EB9-B	YB9-B
	Crono Kick-Starter	125	-	RHB9-B		EB9-B	YB9-B
	CX El. Starter	125	-	RHB9-B		EB9-B	YB9-B
	CX Kick Starter	125	-	RHB9-B		EB9-B	YB9-B
	DNA	50	00-07	RHTX4L-BS	0012310	ETX4L-BS	YTX4L-BS
	Eaglet	50	95-97	RHB4L-B	0012180	EB4L-B	YB4L-B
	Easy Moving	50	95-96	RHB4L-B	0012180	EB4L-B	YB4L-B
	Fast Bike El. -Starter	125	-	RHB9-B		EB9-B	YB9-B
	Fast Bike El. -Starter	200	-	RHB9-B		EB9-B	YB9-B
	Freestyle El. -Starter	125	-	RHB9-B		EB9-B	YB9-B
	GFR EL-Starter	125	-	RHB9-B		EB9-B	YB9-B
	GSA El. -Starter	50	-	RHB4L-B	0012180	EB4L-B	YB4L-B
	GSM	50	99-01	RHB4L-B	0012180	EB4L-B	YB4L-B
	Ice	50	01-05	RHTX4L-BS	0012310	ETX4L-BS	YTX4L-BS
	KK, KZ E-Starter	125	-	RHB9-B		EB9-B	YB9-B
MX1, MXR El. -Starter	125	-	RHB9-B		EB9-B	YB9-B	
Nebraska El. -Starter	125	-	RHB9-B		EB9-B	YB9-B	
Nexus	125	07-08	RHB10L-B-P	0012480	EB10L-B	YB10L-B	
Nexus	250	06	RHTX14-BS	0012390	ETX14-BS	YTX14-BS	
Nexus	250	07	RHTX14-BS	0012390	ETX14-BS	YTX14-BS	
Nexus	300	08-10	RHTX14-BS	0012390	ETX14-BS	YTX14-BS	
Nexus	500	06-07	RHTX14-BS	0012390	ETX14-BS	YTX14-BS	
Nexus	500	03-08	RHTX14-BS	0012390	ETX14-BS	YTX14-BS	
Nexus SP	250	06-07	RHTX14-BS	0012390	ETX14-BS	YTX14-BS	
R1, R1S El. -Starter	125	-	RHB9-B		EB9-B	YB9-B	
RC Rally	125	-	RHB10L-B-P	0012480	EB10L-B	YB10L-B	
RCR	50	06-07	RHB4L-B	0012180	EB4L-B	YB4L-B	
RK Cannibal	50	96-98	RHB4L-B	0012180	EB4L-B	YB4L-B	
RTX, RV, RX El. -Starter	200	-	RHB9-B		EB9-B	YB9-B	
RTX, RV, RX, El. -Starter	125	-	RHB9-B		EB9-B	YB9-B	
RTX(E-Starter)	125	-	RHB9-B		EB9-B	YB9-B	
Runner	50	-97	RHB4L-B	0012180	EB4L-B	YB4L-B	
Runner VXR 4T	200	10	RHTX12-BS	0012320	ETX12-BS	YTX12-BS	
Runner VXR 4T	200	05-07	RHB10L-B-P	0012480	EB10L-B	YB10L-B	

BATTERIE MOTO - ATV, UTV - MARINE

MARCA MAKE	MODELLO MODEL	CC CC	ANNO YEAR	BATTERIA RHIAG RHIAG BATTERY	BATTERIA MPT MOTORPARTS BATTERY	BATTERIA EXIDE EXIDE BATTERY	BATTERIA YUASA YUASA BATTERY	
GILERA	Runner 125	125	10	RHTX14-BS	0012390	ETX14-BS	YTX14-BS	
	Runner FX,PD,VX	125	02-08	RHB9-B		EB9-B	YB9-B	
	Runner FXR, SP	180	97-02	RHB9-B		EB9-B	YB9-B	
	Runner Poggiali	50	02	RHTX4L-BS	0012310	ETX4L-BS	YTX4L-BS	
	Runner Pure Jet	50	02-08	RHB9-B		EB9-B	YB9-B	
	Runner SP	50	02-08	RHB4L-B	0012180	EB4L-B	YB4L-B	
	Runner SP	180	99	RHTX12-BS	0012320	ETX12-BS	YTX12-BS	
	Runner SP Special Edition	50	07	RHB9-B		EB9-B	YB9-B	
	Runner SP ST	50	08	RHB9-B		EB9-B	YB9-B	
	Runner VX 4T	125	-	RHB10L-B-P	0012480	EB10L-B	YB10L-B	
	Runner VXR 4T	180	-	RHT12B-BS	0012550	ET12B-BS	YT12B-BS	
	RV NGR El.-Starter	250	-	RHB10L-B-P	0012480	EB10L-B	YB10L-B	
	RV-(E-Starter)	125	-	RHB9-B		EB9-B	YB9-B	
	SC	125	06	RHB9-B		EB9-B	YB9-B	
	Sioux El.- Starter	50	-	RHB4L-B	0012180	EB4L-B	YB4L-B	
	SMT	50	06-07	RHB4L-B	0012180	EB4L-B	YB4L-B	
	SP	50	10	RHB9-B		EB9-B	YB9-B	
	SP01, SP02 El.-Starter	125	-	RHB9-B		EB9-B	YB9-B	
	Stalker, Storm, Top Rally	50	97-08	RHB4L-B	0012180	EB4L-B	YB4L-B	
	Storm Euro2	50	07	RHB9-B		EB9-B	YB9-B	
	Top Rally	50	-	RHB4L-B	0012180	EB4L-B	YB4L-B	
	TOP Rally El.-Starter	125	-	RHB9-B		EB9-B	YB9-B	
	Typhoon	125	95-98	RHB9-B		EB9-B	YB9-B	
	Typhoon, X	50	94-00	RHB4L-B	0012180	EB4L-B	YB4L-B	
	XR1, XR2 E.I.-Starter	125	-	RHB9-B		EB9-B	YB9-B	
	Zulu	50	01	RHB4L-B	0012180	EB4L-B	YB4L-B	
	HARLEY-DAVIDSON	BLACKLINE	1584	11-	RHTX20L-BS	0012640		YTX20L-BS
		Cross BONES	1584	11-	RHTX20L-BS	0012640		YTX20L-BS
		CVO FLST (Softail)	1802	10-	RHTX20L-BS	0012640		YTX20L-BS
		CVO FLST (Softail)	1803	10-	RHTX20L-BS	0012640		YTX20L-BS
		CVO FXD Fat Bob (Dyna)	1803	10	RHTX20L-BS	0012640		YTX20L-BS
		CVO softtail CONVERTIBLE	1802	11-	RHTX20L-BS	0012640		YTX20L-BS
		Fat BOB	1584	11-	RHTX20L-BS	0012640		YTX20L-BS
Fat BOY		1584	11-	RHTX20L-BS	0012640		YTX20L-BS	
Fat Boy Special		1584	11-	RHTX20L-BS	0012640		YTX20L-BS	
FL, FLH (Touring)		1340	97-98	RHB30L-B			YB30L-B	
FL, FLH (Touring)		1450	99	RHB30L-B			YB30L-B	
FLS (Softail) 1690		1690	11-	RHTX20L-BS	0012640		YTX20L-BS	
FLST Series		1340	91-96	RHTX20L-BS	0012640		YTX20L-BS	
FLST Series		1340	97-00	RHTX20L-BS	0012640		YTX20L-BS	
FXD Series		1340	97-00	RHTX20L-BS	0012640		YTX20L-BS	
FXD Series		1450	99-06	RHTX20L-BS	0012640		YTX20L-BS	
FXD Series		1570	07-10	RHTX20L-BS	0012640		YTX20L-BS	
FXD Series (Dyna)		1584	07-11	RHTX20L-BS	0012640		YTX20L-BS	
FXD Series (Dyna) 1690		1690	11-	RHTX20L-BS	0012640		YTX20L-BS	
FXST Series		1340	97-00	RHTX20L-BS	0012640		YTX20L-BS	
FXST, FLST		1450	00-	RHTX20L-BS	0012640		YTX20L-BS	
FXST, FLST		1570	07-10	RHTX20L-BS	0012640		YTX20L-BS	
FXST, FLST Series (Softail)		1584	10-	RHTX20L-BS	0012640		YTX20L-BS	
Heritage Softail CLASSIC		1584	11-	RHTX20L-BS	0012640		YTX20L-BS	
Heritage Softail CLASSIC		1690	12	RHTX20L-BS	0012640		YTX20L-BS	

MARCA	MODELLO	CC	ANNO	BATTERIA RHIAG	BATTERIA MPT	BATTERIA EXIDE	BATTERIA YUASA	
MAKE	MODEL	CC	YEAR	RHIAG BATTERY	MOTORPARTS BATTERY	EXIDE BATTERY	YUASA BATTERY	
HARLEY-DAVIDSON	Night ROD Special	1247	11-	RHTX20L-BS	0012640		YTX20L-BS	
	Rocker C	1584	11-	RHTX20L-BS	0012640		YTX20L-BS	
	Servi-car	750	32-63	RHTX20L-BS	0012640		YTX20L-BS	
	Softail DELUXE	1584	11-	RHTX20L-BS	0012640		YTX20L-BS	
	Softail Slim	1688	12	RHTX20L-BS	0012640		YTX20L-BS	
	Sportster	900	52-66	RHTX14-BS	0012390	ETX14-BS	YTX14-BS	
	Street BOB	1584	11-	RHTX20L-BS	0012640		YTX20L-BS	
	Super Glide CUSTOM	1584	11-	RHTX20L-BS	0012640		YTX20L-BS	
	SWITCHBACK	1690	11-	RHTX20L-BS	0012640		YTX20L-BS	
	V-ROD 10th Anniversary Edition	1247	12-	RHTX20L-BS	0012640		YTX20L-BS	
	V-ROD Muscle	1247	11-	RHTX20L-BS	0012640		YTX20L-BS	
	VRSC V-Road	1250	08-10	RHTX20L-BS	0012640		YTX20L-BS	
	Wide Glide	1584	11-	RHTX20L-BS	0012640		YTX20L-BS	
	XL, XLH	883	97-03	RHTX20L-BS	0012640		YTX20L-BS	
	XL/XLH Series	1200	97-03	RHTX20L-BS	0012640		YTX20L-BS	
	HERCULES	FOX	50	93	RHB5L-B	0012240	EB5L-B	YB5L-B
Gipsy		50	95	RHB4L-B	0012180	EB4L-B	YB4L-B	
KX5		50	93-97	RHB4L-B	0012180	EB4L-B	YB4L-B	
Limbo L., M,MA, ML		50	95-97	RHB4L-B	0012180	EB4L-B	YB4L-B	
Reggagge, Reggagge, splinter		50	96-97	RHB4L-B	0012180	EB4L-B	YB4L-B	
Roadster		800	-	RHTX14-BS	0012390	ETX14-BS	YTX14-BS	
RX 9		80	-	RHB5L-B	0012240	EB5L-B	YB5L-B	
Samba, Swing		50	94-97	RHB4L-B	0012180	EB4L-B	YB4L-B	
Squab		50	97	RHB4L-B	0012180	EB4L-B	YB4L-B	
SR-125 Samba		125	94-97	RHB5L-B	0012240	EB5L-B	YB5L-B	
SR-Samba		80	94-96	RHB5L-B	0012240	EB5L-B	YB5L-B	
ZX		50	95-97	RHB4L-B	0012180	EB4L-B	YB4L-B	
ZX		125	97	RHB5L-B	0012240	EB5L-B	YB5L-B	
HM		230F Enduro, Motard, Trial	230	04-07	RHTX5L-BS	0012380	ETX5L-BS	YTX5L-BS
		CRE	250	05-08	RHTX5L-BS	0012380	ETX5L-BS	YTX5L-BS
		Cre Six, Baja, Derapage	50	07-08	RHTX4L-BS	0012310	ETX4L-BS	YTX4L-BS
	CRE X IE	450	07-08	RHTZ7S-BS	0012500		YTZ7S-BS	
	CRE X IE	490	07-08	RHTZ7S-BS	0012500		YTZ7S-BS	
	CRF X 5-8	450	05-08	RHTZ7S-BS	0012500		YTZ7S-BS	
HONDA	CRM	250	05-08	RHTX5L-BS	0012380	ETX5L-BS	YTX5L-BS	
	@	125	-	RHTX7L-BS	0012430	ETX7L-BS	YTX7L-BS	
	@	150	-	RHTX7L-BS	0012430	ETX7L-BS	YTX7L-BS	
	BC100	100	-	RHTX4L-BS	0012310	ETX4L-BS	YTX4L-BS	
	Bite	50	01-	RHTZ7S-BS	0012500		YTZ7S-BS	
	BOBY	50	01-	RHTZ7S-BS	0012500		YTZ7S-BS	
	C100-M	100	88-92	RHB5L-B	0012240	EB5L-B	YB5L-B	
	C100-MA	100	87	RHTX4L-BS	0012310	ETX4L-BS	YTX4L-BS	
	C100-TH	100	92	RHTX4L-BS	0012310	ETX4L-BS	YTX4L-BS	
	C110	110	09-10	RHTZ7S-BS	0012500		YTZ7S-BS	
	C110B	110	10-	RHTZ7S-BS	0012500		YTZ7S-BS	
	C50SW	50	94	RHB4L-B	0012180	EB4L-B	YB4L-B	
	C70 Passport	70	82-83	RHB5L-B	0012240	EB5L-B	YB5L-B	
	C70, DM	70	82-84	RHB5L-B	0012240	EB5L-B	YB5L-B	
	C70CMP	70	97	RHB4L-B	0012180	EB4L-B	YB4L-B	
	C70W	70	95	RHB4L-B	0012180	EB4L-B	YB4L-B	
C90, CW	90	95	RHB4L-B	0012180	EB4L-B	YB4L-B		

BATTERIE MOTO
ATV/UTV/MARINE

BATTERIE MOTO - ATV, UTV - MARINE

MARCA MAKE	MODELLO MODEL	CC CC	ANNO YEAR	BATTERIA RHIAG RHIAG BATTERY	BATTERIA MPT MOTORPARTS BATTERY	BATTERIA EXIDE EXIDE BATTERY	BATTERIA YUASA YUASA BATTERY
HONDA	C90, M	90	82-93	RHB5L-B	0012240	EB5L-B	YB5L-B
	CA125	125	95-96	RHTX7L-BS	0012430	ETX7L-BS	YTX7L-BS
	CA125 Rebel	125	95-97	RHTX7L-BS	0012430	ETX7L-BS	YTX7L-BS
	CA250 T	250	95	RHTX7L-BS	0012430	ETX7L-BS	YTX7L-BS
	CA250TS	250	97	RHTX7L-BS	0012430	ETX7L-BS	YTX7L-BS
	CB 1300S C-ABS	1300	12	RHTZ14S-BS	0012580		YTZ14S-BS
	CB F Hornet/S 02/03	600	-	RHTZ7S-BS	0012500		YTZ7S-BS
	CB F Hornet/S 98/01	600	-	RHTX7L-BS	0012430	ETX7L-BS	YTX7L-BS
	CB1000	1000	94-95	RHTX12-BS	0012320	ETX12-BS	YTX12-BS
	CB1000F	1000	93-95	RHTX12-BS	0012320	ETX12-BS	YTX12-BS
	CB1000FT	1000	93-96	RHTX12-BS	0012320	ETX12-BS	YTX12-BS
	CB1000R	1000	09-10	RHTZ10S-BS	0012540		YTZ10S-BS
	CB1100	1100	10	RHTZ14S-BS	0012580		YTZ14S-BS
	CB1100SF	1100	-	RHTX12-BS	0012320	ETX12-BS	YTX12-BS
	CB125 TD	125	82	RHB9-B		EB9-B	YB9-B
	CB1300 Super Four	1300	01-	RHTZ14S-BS	0012580		YTZ14S-BS
	CB1300DC X4 Type LD	1300	01-	RHTX14-BS	0012390	ETX14-BS	YTX14-BS
	CB160, CL160, D	160	65-69	RHB9-B		EB9-B	YB9-B
	CB175 Super Sport	175	69-73	RHB9-B		EB9-B	YB9-B
	CB200, T	200	74-76	RHB9-B		EB9-B	YB9-B
	CB223S	223	10-	RHTZ7S-BS	0012500		YTZ7S-BS
	CB250	250	91-97	RHTX7L-BS	0012430	ETX7L-BS	YTX7L-BS
	CB250 Nighthawk	250	91-07	RHTX7L-BS	0012430	ETX7L-BS	YTX7L-BS
	CB250 RS	250	80	RHB9-B		EB9-B	YB9-B
	CB250, R	250	94-99	RHTX7L-BS	0012430	ETX7L-BS	YTX7L-BS
	CB250FV Hornet	250	-	RHTX7L-BS	0012430	ETX7L-BS	YTX7L-BS
	CB400 Super Four	400	01-	RHTZ10S-BS	0012540		YTZ10S-BS
	CB400F CB-1	400	89-90	RHTX9-BS	0012330	ETX9-BS	YTX9-BS
	CB400SF/SB	400	10-	RHTZ10S-BS	0012540		YTZ10S-BS
	CB400T Hawk I	400	78-79	RHB9-B		EB9-B	YB9-B
	CB450N	450	85	RHB12AL-A	0012340	EB12AL-A	YB12AL-A
	CB500	500	04-	RHTZ10S-BS	0012540		YTZ10S-BS
	CB500, S	500	94-96	RHTX9-BS	0012330	ETX9-BS	YTX9-BS
	CB550	550	83-84	RHB12AL-A	0012340	EB12AL-A	YB12AL-A
	CB550SC Nighthawk	550	83	RHB12AL-A	0012340	EB12AL-A	YB12AL-A
	CB600 F	600	04-06	RHTX7L-BS	0012430	ETX7L-BS	YTX7L-BS
	CB600 F HORNET	600	98	RHTX7L-BS	0012430	ETX7L-BS	YTX7L-BS
	CB600 F HORNET	600	01-	RHTZ7S-BS	0012500		YTZ7S-BS
	CB600 F, HORNET, ABS	600	04	RHTX7L-BS	0012430	ETX7L-BS	YTX7L-BS
	CB600 SF	600	02	RHTZ7S-BS/RHTX7L-BS	0012380	ETX7L-BS	YTX7L-BS
	CB600F	600	07-08	RHTZ10S-BS	0012540		YTZ10S-BS
	CB600F (599)	600	04-06	RHTX7L-BS	0012430	ETX7L-BS	YTX7L-BS
	CB650 SC Nighthawk	650	83-85	RHB12AL-A	0012340	EB12AL-A	YB12AL-A
	CB900F Hornet	900	01-	RHTZ10S-BS	0012540		YTZ10S-BS
	CBF	125	09-	RHTX7L-BS	0012430	ETX7L-BS	YTX7L-BS
	CBF1000F	1000	09-10	RHTZ10S-BS	0012540		YTZ10S-BS
	CBF500	500	04-	RHTZ10S-BS	0012540		YTZ10S-BS
	CBF600	600	07	RHTZ10S-BS	0012540		YTZ10S-BS
	CBF600N,NA	600	03-07	RHTX7L-BS	0012430	ETX7L-BS	YTX7L-BS
	CBF600S, SA	600	03-07	RHTX7L-BS	0012430	ETX7L-BS	YTX7L-BS
	CBR	1100	-	RHB12AL-A	0012340	EB12AL-A	YB12AL-A

MARCA	MODELLO	CC	ANNO	BATTERIA RHIAG	BATTERIA MPT	BATTERIA EXIDE	BATTERIA YUASA
MAKE	MODEL	CC	YEAR	RHIAG BATTERY	MOTORPARTS BATTERY	EXIDE BATTERY	YUASA BATTERY
HONDA	CBR 125	125	07	RHTZ75-BS	0012500		YTZ75-BS
	CBR 900F	919	02-06	RHTZ10S-BS	0012540		YTZ10S-BS
	CBR R (PC44) / RA ABS	500	13-	RHTZ10S-BS	0012540		YTZ10S-BS
	CBR1000 XX	1000	01-04	RHTZ12S-BS		ELTZ14S	YTZ12-S
	CBR1000RR	1000	10-	RHTZ75-BS	0012500		YTZ75-BS
	CBR1000RR (ABS)	1000	10-	RHTZ10S-BS	0012540		YTZ10S-BS
	CBR1000RR Fireblade	1000	07-	RHTZ75-BS	0012500		YTZ75-BS
	CBR1000RR Fireblade (SC57)	1000	04-07	RHTZ10S-BS	0012540		YTZ10S-BS
	CBR1100 XX	1100	01-	RHTZ12S-BS		ELTZ14S	YTZ12-S
	CBR1100 XX Blackbird	1100	97-98	RHTX12-BS	0012320	ETX12-BS	YTX12-BS
	CBR1100XX Super Sport	1100	97-00	RHTX12-BS	0012320	ETX12-BS	YTX12-BS
	CBR125	125	07	RHTZ75-BS	0012500		YTZ75-BS
	CBR250R	250	11-	RHTX7L-BS	0012430	ETX7L-BS	YTX7L-BS
	CBR250RR	250	-	RHTX7L-BS	0012430	ETX7L-BS	YTX7L-BS
	CBR400RRR	400	86-89	RHTX9-BS	0012330	ETX9-BS	YTX9-BS
	CBR400RRR	400	92-94	RHTX7L-BS	0012430	ETX7L-BS	YTX7L-BS
	CBR500F	500	87-89	RHTX9-BS	0012330	ETX9-BS	YTX9-BS
	CBR600	600	87-00	RHTX9-BS	0012330	ETX9-BS	YTX9-BS
	CBR600 F, FII, FIII, SE	600	95-99	RHTX9-BS	0012330	ETX9-BS	YTX9-BS
	CBR600 F4i	600	01-05	RHTZ10S-BS	0012540		YTZ10S-BS
	CBR600 F4i,600RR	600	01-	RHTZ10S-BS	0012540		YTZ10S-BS
	CBR600F	600	87-88	RHTX9-BS	0012330	ETX9-BS	YTX9-BS
	CBR600F/SP	600	01-	RHTZ10S-BS	0012540		YTZ10S-BS
	CBR600F/SP	600	87-00	RHTX9-BS	0012330	ETX9-BS	YTX9-BS
	CBR600FS/SX	600	01-	RHTZ10S-BS	0012540		YTZ10S-BS
	CBR900RR FireBlade	900	00-02	RHTZ10S-BS	0012540		YTZ10S-BS
	CBR900RR FireBlade	900	92-99	RHTX9-BS	0012330	ETX9-BS	YTX9-BS
	CBR929RR	929	00-	RHTZ10S-BS	0012540		YTZ10S-BS
	CBR954RR	954	01-	RHTZ10S-BS	0012540		YTZ10S-BS
	CBX1000 Super Sport	1000	79-82	RHTX20L-BS	0012640		YTX20L-BS
	CBX250 TWISTER	250	-	RHTX7L-BS	0012430	ETX7L-BS	YTX7L-BS
	CBX250, RS-YA	250	85-87	RHTX9-BS	0012330	ETX9-BS	YTX9-BS
	CBX550F, FII	550	82-83	RHB12AL-A	0012340	EB12AL-A	YB12AL-A
	CBX600E	600	83	RHB12AL-A	0012340	EB12AL-A	YB12AL-A
	CBX650E Nighthawk	650	82-83	RHB12AL-A	0012340	EB12AL-A	YB12AL-A
	CD125 T	125	-	RHB9-B		EB9-B	YB9-B
	CD250 U	250	85-89	RHTX9-BS	0012330	ETX9-BS	YTX9-BS
	CFR150	150	06-07	RHTX5L-BS	0012380	ETX5L-BS	YTX5L-BS
	CG125 (E-Stater)	125	-	RHTX5L-BS	0012380	ETX5L-BS	YTX5L-BS
	CG125 (Kick-Stater)	125	-	RHTX4L-BS	0012310	ETX4L-BS	YTX4L-BS
	CG150 TITAN	150	-	RHTX7L-BS	0012430	ETX7L-BS	YTX7L-BS
	CH125	125	84	RHB9-B		EB9-B	YB9-B
	CH125 Elite	125	84	RHB9-B		EB9-B	YB9-B
	CH125 Spacy	125	88-95	RHTX9-BS	0012330	ETX9-BS	YTX9-BS
	CH150 Elite	150	87	RHTX9-BS	0012330	ETX9-BS	YTX9-BS
CH150 Elite Deluxe	150	85-86	RHB9-B		EB9-B	YB9-B	
CH250	250	87-89	RHTX12-BS	0012320	ETX12-BS	YTX12-BS	
CH250 Elite	250	85-90	RHTX12-BS	0012320	ETX12-BS	YTX12-BS	
CH80	80	86	RHTX5L-BS	0012380	ETX5L-BS	YTX5L-BS	
CH80 Elite	80	93-09	RHTX5L-BS	0012380	ETX5L-BS	YTX5L-BS	
CHA125T	125	96	RHTX9-BS	0012330	ETX9-BS	YTX9-BS	

BATTERIE MOTO - ATV, UTV - MARINE

MARCA MAKE	MODELLO MODEL	CC CC	ANNO YEAR	BATTERIA RHIAG RHIAG BATTERY	BATTERIA MPT MOTORPARTS BATTERY	BATTERIA EXIDE EXIDE BATTERY	BATTERIA YUASA YUASA BATTERY
HONDA	CHF 50 Metropolitan,II,S	50	02-10	RHTZ75-BS	0012500		YTZ75-BS
	CHF50	50	09-	RHTZ75-BS	0012500		YTZ75-BS
	City Fly	125	98	RHTX5L-BS	0012380	ETX5L-BS	YTX5L-BS
	CJ250 T	250	-	RHB9-B		EB9-B	YB9-B
	CJ360T	360	76-77	RHB9-B		EB9-B	YB9-B
	CL175 Scrambler	175	68-73	RHB9-B		EB9-B	YB9-B
	CL200 Scrambler	200	74	RHB9-B		EB9-B	YB9-B
	CL250 S	250	82	RHB9-B		EB9-B	YB9-B
	CLR 125	125	-99	RHTX5L-BS	0012380	ETX5L-BS	YTX5L-BS
	CM125 C	125	82-94	RHB9-B		EB9-B	YB9-B
	CM200 T	200	85-88	RHTX12-BS	0012320	ETX12-BS	YTX12-BS
	CM200 T Twinstar	200	81-82	RHB9-B		EB9-B	YB9-B
	CM250C Custom	250	82-83	RHB9-B		EB9-B	YB9-B
	CMX	125	-	RHTX7L-BS	0012430	ETX7L-BS	YTX7L-BS
	CMX250	250	-	RHTX7L-BS	0012430	ETX7L-BS	YTX7L-BS
	CMX250 C Rebel	250	96-10	RHTX7L-BS	0012430	ETX7L-BS	YTX7L-BS
	CMX250C3	250	01-	RHTX7L-BS	0012430	ETX7L-BS	YTX7L-BS
	CN250 Helix	250	86-92	RHTX12-BS	0012320	ETX12-BS	YTX12-BS
	CN250 Helix	250	93-09	RHTX12-BS	0012320	ETX12-BS	YTX12-BS
	CN250 Helix, Fusion typeXX	250	86-07	RHTX12-BS	0012320	ETX12-BS	YTX12-BS
	CR750 45	750	-	RHTX9-BS	0012330	ETX9-BS	YTX9-BS
	CRF	250	12-	RHTX7L-BS	0012430	ETX7L-BS	YTX7L-BS
	CRF 150F	150	06-14	RHTZ75-BS	0012500		YTZ75-BS
	CRF X	450	05-	RHTZ75-BS	0012500		YTZ75-BS
	CRF125F	125	14-	RHTX4L-BS	0012310	ETX4L-BS	YTX4L-BS
	CRF230F	230	03-10	RHTX5L-BS/RHTZ75-BS	0012380	ETX5L-BS	YTX5L-BS
	CRF230L	230	08-14	RHTZ75-BS	0012500		YTZ75-BS
	CRF230L	230	14-	RHTX7L-BS	0012430	ETX7L-BS	YTX7L-BS
	CRF250 X	250	04-09	RHTX5L-BS/RHTZ75-BS	0012380	ETX5L-BS	YTX5L-BS
	CRM	125	-	RHTX4L-BS	0012310	ETX4L-BS	YTX4L-BS
	CRM125 R	125	90	RHTX4L-BS	0012310	ETX4L-BS	YTX4L-BS
	Crossrunner, VFR 800X	800	-11	RHTZ12S-BS		ELTZ14S	YTZ12-S
	Crosstourer (DCT) C-ABS	1250	12	RHTZ14S-BS	0012580		YTZ14S-BS
	CT200	200	86-89	RHB9-B		EB9-B	YB9-B
	CT70	70	91-94	RHTX4L-BS	0012310	ETX4L-BS	YTX4L-BS
	CT70 (Canada)	70	91-94	RHTX4L-BS	0012310	ETX4L-BS	YTX4L-BS
	CT750C, CA, C2 Shadow, Spirit, Aero	750	07-09	RHTZ12S-BS		ELTZ14S	YTZ12-S
	CTX	700	14-	RHTZ12S-BS		ELTZ14S	YTZ12-S
	Deauville	650	-	RHTX9-BS	0012330	ETX9-BS	YTX9-BS
	Deauville 700 C-ABS	700	-12	RHTZ14S-BS	0012580		YTZ14S-BS
	Dio 50 (SP50 Dio)	50	93-94	RHTX4L-BS	0012310	ETX4L-BS	YTX4L-BS
	Dio Z4	50	02-	RHTZ75-BS	0012500		YTZ75-BS
	DN-01	680	10	RHTZ14S-BS	0012580		YTZ14S-BS
	Dylan	125	-	RHTX7L-BS	0012430	ETX7L-BS	YTX7L-BS
	Dylan	150	-	RHTX7L-BS	0012430	ETX7L-BS	YTX7L-BS
	EVCS0	50	10-	RHTX4L-BS	0012310	ETX4L-BS	YTX4L-BS
	EX Bali	100	97	RHTX5L-BS	0012380	ETX5L-BS	YTX5L-BS
EZ90 (Cub)	90	91-96	RHTX5L-BS	0012380	ETX5L-BS	YTX5L-BS	
FES125, Panteon	125	03-	RHTX7L-BS	0012430	ETX7L-BS	YTX7L-BS	
FES150	150	03-	RHTX7L-BS	0012430	ETX7L-BS	YTX7L-BS	
FES150	150	99-02	RHTX9-BS	0012330	ETX9-BS	YTX9-BS	

MARCA	MODELLO	CC	ANNO	BATTERIA RHIAG	BATTERIA MPT	BATTERIA EXIDE	BATTERIA YUASA
MAKE	MODEL	CC	YEAR	RHIAG BATTERY	MOTORPARTS BATTERY	EXIDE BATTERY	YUASA BATTERY
HONDA	FES250 Foresight	250	01-	RHTZ12S-BS		ELTZ14S	YTZ12-S
	FES250V Foresight	250	97-99	RHTX12-BS	0012320	ETX12-BS	YTX12-BS
	Fifty	50	-	RHB4L-B	0012180	EB4L-B	YB4L-B
	FJS Silver Wing	600	11-	RHTZ12S-BS		ELTZ14S	YTZ12-S
	FJS600, Silver Wing	600	01-	RHTZ12S-BS		ELTZ14S	YTZ12-S
	FJS600DB/AB	600	10-	RHTZ12S-BS		ELTZ14S	YTZ12-S
	Foresight 150	150	-	RHTX7L-BS	0012430	ETX7L-BS	YTX7L-BS
	Foresight FES (MF04 05)	250	00-05	RHTZ12S-BS		ELTZ14S	YTZ12-S
	Forza 250	250	01-	RHTZ12S-BS		ELTZ14S	YTZ12-S
	Forza X, Z	250	01-	RHTZ12S-BS		ELTZ14S	YTZ12-S
	FSC600	600	10-	RHTZ12S-BS		ELTZ14S	YTZ12-S
	FSC600 Silver Wing	582	02-10	RHTZ12S-BS		ELTZ14S	YTZ12-S
	FTR	225	-	RHTX5L-BS	0012380	ETX5L-BS	YTX5L-BS
	FTR	250	-	RHTX5L-BS	0012380	ETX5L-BS	YTX5L-BS
	FX650	650	-99	RHTX9-BS	0012330	ETX9-BS	YTX9-BS
	Giorcub	50	01-	RHTZ7S-BS	0012500		YTZ7S-BS
	Giorno	50	01-	RHTZ7S-BS	0012500		YTZ7S-BS
	GL F6C	1500	-	RHTX14-BS	0012390	ETX14-BS	YTX14-BS
	GL1500 Valkyrie	1500	97-03	RHTX14-BS	0012390	ETX14-BS	YTX14-BS
	GL1800 Gold Wing	1800	01-08	RHTX20L-BS	0012640		YTX20L-BS
	GL1800A GOLD WING	1800	01-14	RHTX20L-BS	0012640		YTX20L-BS
	Gp dio	50	-	RHTX4L-BS	0012310	ETX4L-BS	YTX4L-BS
	Gyro Canopy	50	00-	RHTX7L-BS	0012430	ETX7L-BS	YTX7L-BS
	Gyro Up	50	00-	RHTX7L-BS	0012430	ETX7L-BS	YTX7L-BS
	Gyro X	50	00-	RHTX7L-BS	0012430	ETX7L-BS	YTX7L-BS
	Hornet	600	98	RHTX7L-BS	0012430	ETX7L-BS	YTX7L-BS
	Integra C-ABS	670	11-	RHTZ12S-BS		ELTZ14S	YTZ12-S
	Jazz	250	-	RHTZ12S-BS		ELTZ14S	YTZ12-S
	Julio	50	01-	RHTZ7S-BS	0012500		YTZ7S-BS
	KGB	50	-99	RHTZ7S-BS	0012500		YTZ7S-BS
	Lead	50	-	RHB4L-B	0012180	EB4L-B	YB4L-B
	Lead	50	01-	RHTZ7S-BS	0012500		YTZ7S-BS
	LEAD	100	08	RHTX7L-BS	0012430	ETX7L-BS	YTX7L-BS
	Little Cub	50	00-	RHTX4L-BS	0012310	ETX4L-BS	YTX4L-BS
	MBX 125 F	125	85	RHB5L-B	0012240	EB5L-B	YB5L-B
	MTX 125, R, R2	125	86-87	RHB5L-B	0012240	EB5L-B	YB5L-B
	NB 50 M	50	82	RHB4L-B	0012180	EB4L-B	YB4L-B
	NB 50, M	50	83-87	RHTX4L-BS	0012310	ETX4L-BS	YTX4L-BS
	NB50 Aero	50	85-87	RHTX4L-BS	0012310	ETX4L-BS	YTX4L-BS
	NB50M Aero	50	83-84	RHB4L-B	0012180	EB4L-B	YB4L-B
	NC700	700	-	RHTZ12S-BS		ELTZ14S	YTZ12-S
	NC700X (DCT) C-ABS	700	12-	RHTZ12S-BS		ELTZ14S	YTZ12-S
	NCH50 Metropolitan	50	13-	RHTX4L-BS	0012310	ETX4L-BS	YTX4L-BS
	NCS 110 Vision	110	11	RHTX7L-BS	0012430	ETX7L-BS	YTX7L-BS
	ND50 M	50	82	RHB4L-B	0012180	EB4L-B	YB4L-B
NES 125	125	00-	RHTX7L-BS	0012430	ETX7L-BS	YTX7L-BS	
NES125, Dylan	125	00-	RHTX7L-BS	0012430	ETX7L-BS	YTX7L-BS	
NES150	150	00-	RHTX7L-BS	0012430	ETX7L-BS	YTX7L-BS	
NES150 Z	150	01	RHTX7L-BS	0012430	ETX7L-BS	YTX7L-BS	
NF 100, M	100	97	RHTX5L-BS	0012380	ETX5L-BS	YTX5L-BS	
NH 50 MS	50	86-98	RHB4L-B	0012180	EB4L-B	YB4L-B	

BATTERIE MOTO - ATV, UTV - MARINE

MARCA	MODELLO	CC	ANNO	BATTERIA RHIAG	BATTERIA MPT	BATTERIA EXIDE	BATTERIA YUASA
MAKE	MODEL	CC	YEAR	RHIAG BATTERY	MOTORPARTS BATTERY	EXIDE BATTERY	YUASA BATTERY
HONDA	NH100-1D	100	98	RHTX5L-BS	0012380	ETX5L-BS	YTX5L-BS
	NH100-1D	100	84-	RHB5L-B	0012240	EB5L-B	YB5L-B
	NH125 Aero	125	84	RHB5L-B	0012240	EB5L-B	YB5L-B
	NH125 Lead	125	83-86	RHB5L-B	0012240	EB5L-B	YB5L-B
	NH80 Aero	80	85	RHTX5L-BS	0012380	ETX5L-BS	YTX5L-BS
	NH80 MD, SD, MS	80	86-94	RHB5L-B	0012240	EB5L-B	YB5L-B
	NH80MD Aero	80	83-84	RHB5L-B	0012240	EB5L-B	YB5L-B
	NHX110 Elite	110	10-	RHTX7L-BS	0012430	ETX7L-BS	YTX7L-BS
	NJ50	50	-	RHTZ7S-BS	0012500		YTZ7S-BS
	NN50MD Gyro	50	84	RHB4L-B	0012180	EB4L-B	YB4L-B
	NP50, M SKY	50	-97	RHB4L-B	0012180	EB4L-B	YB4L-B
	NPS 50, S RUCKUS	50	03-10	RHTZ7S-BS	0012500		YTZ7S-BS
	NQ 50, M	50	85	RHB4L-B	0012180	EB4L-B	YB4L-B
	NQ 50, M	50	86-87	RHTX4L-BS	0012310	ETX4L-BS	YTX4L-BS
	NQ50 Spree	50	84-85	RHB4L-B	0012180	EB4L-B	YB4L-B
	NQ50 Spree, 50D SS	50	86-87	RHTX4L-BS	0012310	ETX4L-BS	YTX4L-BS
	NR750	750	92	RHTX12-BS	0012320	ETX12-BS	YTX12-BS
	NRX 1800 Valkyrie Rune	1800	04-05	RHTX20L-BS	0012640		YTX20L-BS
	NS125 F	125	89	RHB5L-B	0012240	EB5L-B	YB5L-B
	NS125 R, R2, R3	125	87	RHB5L-B	0012240	EB5L-B	YB5L-B
	NS250S	250	-01	RHTZ12S-BS		ELTZ14S	YTZ12-S
	NS400 R/Raiden	400	-	RHTX5L-BS	0012380	ETX5L-BS	YTX5L-BS
	NS400R	400	85	RHTX5L-BS	0012380	ETX5L-BS	YTX5L-BS
	NSC	50	12-	RHTX7L-BS	0012430	ETX7L-BS	YTX7L-BS
	NSC	110	12-	RHTX7L-BS	0012430	ETX7L-BS	YTX7L-BS
	NSR125 F III	125	92	RHTX5L-BS	0012380	ETX5L-BS	YTX5L-BS
	NSR125 R	125	97	RHTX5L-BS	0012380	ETX5L-BS	YTX5L-BS
	NSS 250 REFLEX	250	01-09	RHTZ12S-BS		ELTZ14S	YTZ12-S
	NSS FORZA	300	13-	RHTZ12S-BS		ELTZ14S	YTZ12-S
	NSS250	250	10-	RHTZ12S-BS		ELTZ14S	YTZ12-S
	NTV Deauville (RC47)	650	04-05	RHTZ14S-BS	0012580		YTZ14S-BS
	NT110MV	110	97	RHB4L-B	0012180	EB4L-B	YB4L-B
	NT650 Hawk GT, NX650	650	88-91	RHTX9-BS	0012330	ETX9-BS	YTX9-BS
	NT650V	650	-11	RHTX9-BS	0012330	ETX9-BS	YTX9-BS
	NT650V	650	01-	RHTZ10S-BS	0012540		YTZ10S-BS
	NT700V	700	10	RHTZ14S-BS	0012580		YTZ14S-BS
	NTV600	600	88-92	RHTX9-BS	0012330	ETX9-BS	YTX9-BS
	NTV650 Revere	650	88-97	RHTX9-BS	0012330	ETX9-BS	YTX9-BS
	NU 50M Urban Exp. Delux	50	82-83	RHB4L-B	0012180	EB4L-B	YB4L-B
	NV 400 DC Shadow	400	01-	RHTX14-BS	0012390	ETX14-BS	YTX14-BS
	NV 400 Steed	400	01-	RHTZ10S-BS	0012540		YTZ10S-BS
	NV400 DC Shadow Skasher	400	01-	RHTZ10S-BS	0012540		YTZ10S-BS
	NV400C	400	95	RHTX9-BS	0012330	ETX9-BS	YTX9-BS
	NV600C	600	89-94	RHTX9-BS	0012330	ETX9-BS	YTX9-BS
	NV750, Shadow	750	97-98	RHTX14-BS	0012390	ETX14-BS	YTX14-BS
	NV750, Shadow Slasher	750	01-	RHTZ14S-BS	0012580		YTZ14S-BS
	NX 50M Express SR	50	81-82	RHB4L-B	0012180	EB4L-B	YB4L-B
NX125	125	88-90	RHTX7L-BS	0012430	ETX7L-BS	YTX7L-BS	
NX125 Transcity	125	97	RHTX7L-BS	0012430	ETX7L-BS	YTX7L-BS	
NX250	250	88-95	RHTX7L-BS	0012430	ETX7L-BS	YTX7L-BS	
NX500	500	88-95	RHTX9-BS	0012330	ETX9-BS	YTX9-BS	

MARCA	MODELLO	CC	ANNO	BATTERIA RHIAG	BATTERIA MPT	BATTERIA EXIDE	BATTERIA YUASA
MAKE	MODEL	CC	YEAR	RHIAG BATTERY	MOTORPARTS BATTERY	EXIDE BATTERY	YUASA BATTERY
HONDA	NX650	650	88-89	RHTX9-BS	0012330	ETX9-BS	YTX9-BS
	NX650 Dominator	650	88-97	RHTX9-BS	0012330	ETX9-BS	YTX9-BS
	NZ110 MM	110	93	RHB4L-B	0012180	EB4L-B	YB4L-B
	Pan-European	1300	01	RHTZ14S-BS	0012580		YTZ14S-BS
	Pantheon 4t	125	-	RHTX7L-BS	0012430	ETX7L-BS	YTX7L-BS
	Pantheon 4t	150	-	RHTX7L-BS	0012430	ETX7L-BS	YTX7L-BS
	Pantheon FES (KT06)	125	03-05	RHTX7L-BS	0012430	ETX7L-BS	YTX7L-BS
	Pantheon FES (KT06)	150	03-05	RHTX7L-BS	0012430	ETX7L-BS	YTX7L-BS
	PC800 Pacific Coast	800	89-98	RHTX12-BS	0012320	ETX12-BS	YTX12-BS
	PCX 125	125	10-	RHTZ7S-BS	0012500		YTZ7S-BS
	PK 50, M, SM	50	90-99	RHTX4L-BS	0012310	ETX4L-BS	YTX4L-BS
	Press Cub	50	-	RHTX4L-BS	0012310	ETX4L-BS	YTX4L-BS
	PS 250 BIG RUCKUS	250	05-08	RHTZ12S-BS		ELTZ14S	YTZ12-S
	PX 50 MS	50	84	RHB4L-B	0012180	EB4L-B	YB4L-B
	PXR	50	-	RHB4L-B	0012180	EB4L-B	YB4L-B
	RC 45	750	-	RHTX9-BS	0012330	ETX9-BS	YTX9-BS
	RVF400 (NC35)	400	-	RHTX7A-BS	0012350	ETX7A-BS	YTX7A-BS
	RVF750R	750	94-95	RHTX9-BS	0012330	ETX9-BS	YTX9-BS
	RVT 1000R (RC51)	1000	00-05	RHTZ12S-BS		ELTZ14S	YTZ12-S
	SA 50LX, N, S, SR	50	88-01	RHTX4L-BS	0012310	ETX4L-BS	YTX4L-BS
	SA Vision	50	-	RHTX4L-BS	0012310	ETX4L-BS	YTX4L-BS
	SA75M	75	91	RHTX4L-BS	0012310	ETX4L-BS	YTX4L-BS
	SB 50	50	88-90	RHTX4L-BS	0012310	ETX4L-BS	YTX4L-BS
	SC 01	50	97	RHTX4L-BS	0012310	ETX4L-BS	YTX4L-BS
	SC01	50	01-	RHTX4L-BS	0012310	ETX4L-BS	YTX4L-BS
	Scoopy 75	75	93-94	RHB5L-B	0012240	EB5L-B	YB5L-B
	SCV100	100	03-	RHTX5L-BS	0012380	ETX5L-BS	YTX5L-BS
	SE 50	50	88-89	RHTX4L-BS	0012310	ETX4L-BS	YTX4L-BS
	SE50 Elite	50	87	RHTX4L-BS	0012310	ETX4L-BS	YTX4L-BS
	SES125	125	00-	RHTX7L-BS	0012430	ETX7L-BS	YTX7L-BS
	SES150	150	00-	RHTX7L-BS	0012430	ETX7L-BS	YTX7L-BS
	SG 50M	50	90	RHTX4L-BS	0012310	ETX4L-BS	YTX4L-BS
	SGX50 Sky	50	97	RHTX4L-BS	0012310	ETX4L-BS	YTX4L-BS
	SH	125	-	RHTX7L-BS	0012430	ETX7L-BS	YTX7L-BS
	SH 100	100	-	RHTX5L-BS	0012380	ETX5L-BS	YTX5L-BS
	SH 100 Scoopy	100	96	RHTX5L-BS	0012380	ETX5L-BS	YTX5L-BS
	SH 50	50	87-89	RHB4L-B	0012180	EB4L-B	YB4L-B
	SH 50 Scoopy	50	01-	RHTZ7S-BS	0012500		YTZ7S-BS
	SH125i	125	-12	RHTX7L-BS	0012430	ETX7L-BS	YTX7L-BS
	SH150	150	-	RHTX7L-BS	0012430	ETX7L-BS	YTX7L-BS
	SH150	150	13-	RHTZ7S-BS	0012500		YTZ7S-BS
	SH300	300	10-	RHTZ12S-BS		ELTZ14S	YTZ12-S
	SH75	75	87-89	RHB5L-B	0012240	EB5L-B	YB5L-B
	Shadow	750	-12	RHTZ14S-BS	0012580		YTZ14S-BS
	Shadow 125	125	99	RHTX7L-BS	0012430	ETX7L-BS	YTX7L-BS
	Shadow 50	50	97	RHTX4L-BS	0012310	ETX4L-BS	YTX4L-BS
	Shadow 50	50	01-	RHTX4L-BS	0012310	ETX4L-BS	YTX4L-BS
Shadow 600	600	-	RHTX9-BS	0012330	ETX9-BS	YTX9-BS	
Shadow 90	90	99	RHTX4L-BS	0012310	ETX4L-BS	YTX4L-BS	
Shadow 90	90	-	RHTX5L-BS	0012380	ETX5L-BS	YTX5L-BS	
Silver wing	650	02-05	RHTZ12S-BS		ELTZ14S	YTZ12-S	

BATTERIE MOTO - ATV, UTV - MARINE

MARCA MAKE	MODELLO MODEL	CC CC	ANNO YEAR	BATTERIA RHIAG RHIAG BATTERY	BATTERIA MPT MOTORPARTS BATTERY	BATTERIA EXIDE EXIDE BATTERY	BATTERIA YUASA YUASA BATTERY
HONDA	Silver Wing 400	400	01-	RHTZ12S-BS		ELTZ14S	YTZ12-S
	Silver Wing 600	600	01-	RHTZ12S-BS		ELTZ14S	YTZ12-S
	SilverWing T	400	09-10	RHTZ12S-BS		ELTZ14S	YTZ12-S
	SJ Bali EX	100	97	RHTX5L-BS	0012380	ETX5L-BS	YTX5L-BS
	SK 50, M	50	92-94	RHTX4L-BS	0012310	ETX4L-BS	YTX4L-BS
	Sky	50	00-	RHTX4L-BS	0012310	ETX4L-BS	YTX4L-BS
	Sky Dax	50	99	RHTX4L-BS	0012310	ETX4L-BS	YTX4L-BS
	Sky De Luxe	50	99	RHTX4L-BS	0012310	ETX4L-BS	YTX4L-BS
	SL230	230	-	RHTX5L-BS	0012380	ETX5L-BS	YTX5L-BS
	SL230	250	-	RHTX5L-BS	0012380	ETX5L-BS	YTX5L-BS
	SLR650	650	-11	RHTX9-BS	0012330	ETX9-BS	YTX9-BS
	SM250	250	09-10	RHTZ12S-BS		ELTZ14S	YTZ12-S
	SP Dio	50	-	RHTX4L-BS	0012310	ETX4L-BS	YTX4L-BS
	Spacy 125	125	01-	RHTZ12S-BS			
	SR 50	50	97	RHTX4L-BS	0012310	ETX4L-BS	YTX4L-BS
	ST 50 Dax	50	88-97	RHTX4L-BS	0012310	ETX4L-BS	YTX4L-BS
	ST Pan European	1100	-	RHTX14-BS	0012390	ETX14-BS	YTX14-BS
	ST1100, A Police, Pan Eur.	1100	90-98	RHTX14-BS	0012390	ETX14-BS	YTX14-BS
	ST1100, ST1100A, ABS-TCS	1100	91-02	RHTX14-BS	0012390	ETX14-BS	YTX14-BS
	ST1300, A, P, ABS	1300	03-10	RHTZ14S-BS	0012580		YTZ14S-BS
	ST70	70	89-94	RHTX4L-BS	0012310	ETX4L-BS	YTX4L-BS
	STX1300	1300	01	RHTZ14S-BS	0012580		YTZ14S-BS
	Super Cub	90	-	RHTX4L-BS	0012310	ETX4L-BS	YTX4L-BS
	SW-T400, C-ABS	400	-12	RHTZ12S-BS		ELTZ14S	YTZ12-S
	SW-T600	600	-12	RHTZ12S-BS		ELTZ14S	YTZ12-S
	Tact	50	01-	RHTZ7S-BS	0012500		YTZ7S-BS
	TC 50	50	00-	RHTX7L-BS	0012430	ETX7L-BS	YTX7L-BS
	TG50 Gyro	50	85-86	RHTX4L-BS	0012310	ETX4L-BS	YTX4L-BS
	TH90T	90	96	RHTX4L-BS	0012310	ETX4L-BS	YTX4L-BS
	TLR200 Reflex	200	76-87	RHTX4L-BS	0012310	ETX4L-BS	YTX4L-BS
	TR200	200	86	RHTX9-BS	0012330	ETX9-BS	YTX9-BS
	TR200	200	87	RHTX7A-BS	0012350	ETX7A-BS	YTX7A-BS
	TR200 Fat Cat	200	86	RHTX9-BS	0012330	ETX9-BS	YTX9-BS
	TR200 Fat Cat	200	87	RHTX7A-BS	0012350	ETX7A-BS	YTX7A-BS
	Transalp 700 C-ABS	680	12	RHTZ14S-BS	0012580		YTZ14S-BS
	Varadero	1000	99	RHTX14-BS	0012390	ETX14-BS	YTX14-BS
	VF750C Magna	750	93-94	RHTX9-BS	0012330	ETX9-BS	YTX9-BS
	VF750C, C2, D, Magna, Deluxe	750	94-03	RHTX12-BS	0012320	ETX12-BS	YTX12-BS
	VF750C, CA, C2 Shadow spirit, Aero	750	07-10	RHTZ12S-BS		ELTZ14S	YTZ12-S
	VF800, A Interceptor, ABS	800	02-10	RHTZ12S-BS		ELTZ14S	YTZ12-S
	VF800FI Interceptor	800	98-01	RHTX12-BS	0012320	ETX12-BS	YTX12-BS
	VFR1200F	1200	10-	RHTZ14S-BS	0012580		YTZ14S-BS
	VFR400R III	400	90-91	RHTX7A-BS	0012350	ETX7A-BS	YTX7A-BS
	VFR750F	750	87-89	RHTX12-BS	0012320	ETX12-BS	YTX12-BS
	VFR750F	750	90-97	RHTX12-BS	0012320	ETX12-BS	YTX12-BS
	VFR750R	750	88-90	RHTX9-BS	0012330	ETX9-BS	YTX9-BS
	VFR750R (RC30)	750	90	RHTX9-BS	0012330	ETX9-BS	YTX9-BS
	VFR750R (RC45)	750	94	RHTX9-BS	0012330	ETX9-BS	YTX9-BS
	VFR800	800	01	RHTZ12S-BS		ELTZ14S	YTZ12-S
	VFR800	800	01-	RHTZ12S-BS		ELTZ14S	YTZ12-S
VFR800, A interceptor, ABS	800	02-	RHTZ12S-BS		ELTZ14S	YTZ12-S	

MARCA	MODELLO	CC	ANNO	BATTERIA RHIAG	BATTERIA MPT	BATTERIA EXIDE	BATTERIA YUASA
MAKE	MODEL	CC	YEAR	RHIAG BATTERY	MOTORPARTS BATTERY	EXIDE BATTERY	YUASA BATTERY
HONDA	VFR800F I	800	02	RHTZ12S-BS		ELTZ14S	YTZ12-S
	VFR800P	800	01-	RHTZ14S-BS	0012580		YTZ14S-BS
	VFR800P	800	01-002	RHTZ14S-BS	0012580		YTZ14S-BS
	VFR800X	800	-	RHTZ12S-BS		ELTZ14S	YTZ12-S
	VISION 50	50	12	RHTX4L-BS	0012310	ETX4L-BS	YTX4L-BS
	Vision 50	50	93-94	RHTX4L-BS	0012310	ETX4L-BS	YTX4L-BS
	VT1100 Shadow C2 Sabre	1100	00-07	RHTX14-BS	0012390	ETX14-BS	YTX14-BS
	VT1100C, C II, C IIShadow	1100	98-00	RHTZ14S-BS	0012580		YTZ14S-BS
	VT1100C, C3, T Shadow, Spirit, Aereo, ACE Tourer	1100	01-07	RHTX14-BS	0012390	ETX14-BS	YTX14-BS
	VT1100C, C3, T Shadow, Spirit, Aereo, ACE Tourer	1100	98-00	RHTZ14S-BS	0012580		YTZ14S-BS
	VT1100C2 Shadow, ACE	1100	95-99	RHTZ14S-BS	0012580		YTZ14S-BS
	VT125 Shadow	125	-	RHTX7L-BS	0012430	ETX7L-BS	YTX7L-BS
	VT125C	125	01-	RHTZ7S-BS	0012500		YTZ7S-BS
	VT1300S, C, R, CXA Fury	1300	09-14	RHTZ14S-BS	0012580		YTZ14S-BS
	VT1300S3, VTX Retro	1300	03-07	RHTX14-BS	0012390	ETX14-BS	YTX14-BS
	VT250	250	90-95	RHTX7L-BS	0012430	ETX7L-BS	YTX7L-BS
	VT250CV-TWIN MAGNA	250	-	RHTX7L-BS	0012430	ETX7L-BS	YTX7L-BS
	VT250CS	250	-97	RHTX7L-BS	0012430	ETX7L-BS	YTX7L-BS
	VT400S	400	10-	RHTZ10S-BS	0012540		YTZ10S-BS
	VT600 C Shadow	600	88-99	RHTX9-BS	0012330	ETX9-BS	YTX9-BS
	VT600 C, CD Shadow Deluxe	600	04-07	RHTZ10S-BS	0012540		YTZ10S-BS
	VT600 C, CD Shadow Deluxe, VLX	600	88-03	RHTX9-BS	0012330	ETX9-BS	YTX9-BS
	VT600C	600	88-97	RHTX9-BS	0012330	ETX9-BS	YTX9-BS
	VT750	750	10-	RHTZ14S-BS	0012580		YTZ14S-BS
	VT750 C	750	-	RHTZ14S-BS	0012580		YTZ14S-BS
	VT750C Shadow	750	98-00	RHTX14-BS	0012390	ETX14-BS	YTX14-BS
	VT750C, C II, Shadow	750	04-10	RHTZ12S-BS		ELTZ14S	YTZ12-S
	VT750C, C II, Shadow	750	98-99	RHTX14-BS	0012390	ETX14-BS	YTX14-BS
	VT750C, CA, C2, Shadow Spirit, Aero	750	07-09	RHTZ12S-BS		ELTZ14S	YTZ12-S
	VT750C, CA, CS	750	04-	RHTZ12S-BS		ELTZ14S	YTZ12-S
	VT750CD, CDII, Shadow Dlx	750	98-02	RHTX14-BS	0012390	ETX14-BS	YTX14-BS
	VT750CDA, B, Shadow ACE	750	02-03	RHTX14-BS	0012390	ETX14-BS	YTX14-BS
	VT750DC	750	01-	RHTZ14S-BS	0012580		YTZ14S-BS
	VT750DC Shadow Spirit	750	01-07	RHTZ14S-BS	0012580		YTZ14S-BS
	VT750RS	750	10-	RHTZ14S-BS	0012580		YTZ14S-BS
	VT750S	750	-12	RHTZ14S-BS	0012580		YTZ14S-BS
	VTR1000 F Firestorm	1000	-98	RHTX12-BS	0012320	ETX12-BS	YTX12-BS
	VTR1000 F Firestorm	1000	01-05	RHTZ12S-BS		ELTZ14S	YTZ12-S
	VTR1000 Fsuper Hawk	1000	01-05	RHTZ12S-BS		ELTZ14S	YTZ12-S
	VTR1000 Fsuper Hawk	1000	01-05	RHTZ12S-BS		ELTZ14S	YTZ12-S
	VTR1000 Fsuper Hawk	1000	97-00	RHTX12-BS	0012320	ETX12-BS	YTX12-BS
	VTR1000SP	1000	01-	RHTZ12S-BS		ELTZ14S	YTZ12-S
	VTR1000SP II	1000	04	RHTZ12S-BS		ELTZ14S	YTZ12-S
	VTR250	250	10-	RHTZ7S-BS	0012500		YTZ7S-BS
	VTR250 Interceptor	250	88-90	RHB9-B		EB9-B	YB9-B
	VTX1300C, R, S Retro	1300	03-10	RHTX14-BS	0012390	ETX14-BS	YTX14-BS
	VTX1800C, F, N, R Retro S	1800	02-10	RHTX20L-BS	0012640		YTX20L-BS
	Wallaroo	50	-	RHTX4L-BS	0012310	ETX4L-BS	YTX4L-BS
	WW125EX	125	10-	RHTZ7S-BS	0012500		YTZ7S-BS
	X4	1300	-	RHTX14-BS	0012390	ETX14-BS	YTX14-BS
XL 1000V	1000	-	RHTX20L-BS	0012640		YTX20L-BS	

BATTERIE MOTO - ATV, UTV - MARINE

MARCA MAKE	MODELLO MODEL	CC CC	ANNO YEAR	BATTERIA RHIAG RHIAG BATTERY	BATTERIA MPT MOTORPARTS BATTERY	BATTERIA EXIDE EXIDE BATTERY	BATTERIA YUASA YUASA BATTERY	
HONDA	XL Transalp	650	-	RHTZ12S-BS		ELTZ14S	YTZ12-S	
	XL1000V VARADERO	1000	99-02	RHTX14-BS	0012390	ETX14-BS	YTX14-BS	
	XL125R / Paris Dakar	125	85-87	RHB9-B		EB9-B	YB9-B	
	XL230	250	01-	RHTZ7S-BS	0012500		YTZ7S-BS	
	XL650, V	650	00-	RHTZ12S-BS		ELTZ14S	YTZ12-S	
	XL700V	700	-	RHTZ14S-BS	0012580		YTZ14S-BS	
	XL700V TRANSALP	700	11-	RHTZ14S-BS	0012580		YTZ14S-BS	
	XLR125R	125	98	RHTX7A-BS	0012350	ETX7A-BS	YTX7A-BS	
	XLR150	150	00-	RHTX5L-BS	0012380	ETX5L-BS	YTX5L-BS	
	XLV Varadero	125	-	RHTZ7S-BS	0012500		YTZ7S-BS	
	XR200	200	00-	RHTX7L-BS	0012430	ETX7L-BS	YTX7L-BS	
	XR230	230	01-	RHTZ7S-BS	0012500		YTZ7S-BS	
	XR250	250	-	RHTX5L-BS	0012380	ETX5L-BS	YTX5L-BS	
	XR250 L,R	250	91-98	RHTX4L-BS	0012310	ETX4L-BS	YTX4L-BS	
	XR650L	650	93-14	RHTX9-BS	0012330	ETX9-BS	YTX9-BS	
	XRV750 African Twin	750	93-98	RHTX14-BS	0012390	ETX14-BS	YTX14-BS	
	XV125V	125	01-	RHTZ7S-BS	0012500		YTZ7S-BS	
	ZB 50P Monkey	50	88	RHTX4L-BS	0012310	ETX4L-BS	YTX4L-BS	
	ZB50	50	88	RHTX4L-BS	0012310	ETX4L-BS	YTX4L-BS	
	Zoomer	50	01-	RHTZ7S-BS	0012500		YTZ7S-BS	
	HUSABERG	Fe	250	11-	RHTX4L-BS	0012310	ETX4L-BS	YTX4L-BS
		FE	350	13-	RHTX4L-BS	0012310	ETX4L-BS	YTX4L-BS
		FE, FX, FS (tutti / all)		09-10	RHTZ7S-BS	0012500		YTZ7S-BS
FE450e/6		450	-	RHTZ7S-BS	0012500		YTZ7S-BS	
FE550e/6		550	-	RHTZ7S-BS	0012500		YTZ7S-BS	
FE650e/6		650	-	RHTZ7S-BS	0012500		YTZ7S-BS	
FS450e/6		450	-	RHTZ7S-BS	0012500		YTZ7S-BS	
FS650e/6		650	-	RHTZ7S-BS	0012500		YTZ7S-BS	
LT610, SM610, TE610E		600	01	RHTX14-BS	0012390	ETX14-BS	YTX14-BS	
TE410E		400	01	RHTX14-BS	0012390	ETX14-BS	YTX14-BS	
TE610E, SM610S			00-10	RHTX14-BS	0012390	ETX14-BS	YTX14-BS	
Tutti i modelli (Electric-Start)			01-02	RHTZ7S-BS/RHTX5L-BS	0012380	ETX5L-BS	YTX5L-BS	
Tutti i modelli (Electric-Start)			97-00	RHTX9-BS	0012330	ETX9-BS	YTX9-BS	
HUSQVARNA	511 MR	480	11-	RHTX14-BS	0012390	ETX14-BS	YTX14-BS	
	Nuda 900, R	900	11-	RHTX14-BS	0012390	ETX14-BS	YTX14-BS	
	SM/TE	250	04	RHTZ7S-BS	0012500		YTZ7S-BS	
	SM/TE	450	04	RHTZ7S-BS	0012500		YTZ7S-BS	
	SM/TE	510	04	RHTZ7S-BS	0012500		YTZ7S-BS	
	SM/TE	610	04	RHTX12-BS	0012320	ETX12-BS	YTX12-BS	
	SM125S	125	10-	RHTX4L-BS	0012310	ETX4L-BS	YTX4L-BS	
	SMR 125	125	12	RHTX4L-BS	0012310	ETX4L-BS	YTX4L-BS	
	SMR 511	500	11-	RHTX14-BS	0012390	ETX14-BS	YTX14-BS	
	SMR 630	600	11-	RHTX14-BS	0012390	ETX14-BS	YTX14-BS	
	TC449	450	11-	RHTZ7S-BS	0012500		YTZ7S-BS	
	TE 630	600	11-	RHTX14-BS	0012390	ETX14-BS	YTX14-BS	
	TE E	410	-	RHTX14-BS	0012390	ETX14-BS	YTX14-BS	
	TE E /SM	610	-	RHTX14-BS	0012390	ETX14-BS	YTX14-BS	
	TE125	125	11-	RHTZ7S-BS	0012500		YTZ7S-BS	
	TE250	250	-10	RHTZ7S-BS	0012500		YTZ7S-BS	
	TE250	250	11-	RHTZ7S-BS	0012500		YTZ7S-BS	
	TE310	300	11-	RHTZ7S-BS	0012500		YTZ7S-BS	

MARCA	MODELLO	CC	ANNO	BATTERIA RHIAG	BATTERIA MPT	BATTERIA EXIDE	BATTERIA YUASA	
MAKE	MODEL	CC	YEAR	RHIAG BATTERY	MOTORPARTS BATTERY	EXIDE BATTERY	YUASA BATTERY	
HUSQVARNA	TE449	450	11-	RHTZ75-BS	0012500		YTZ75-BS	
	TR strada	650	13-	RHTX12-BS	0012320	ETX12-BS	YTX12-BS	
	TXC250	250	11-	RHTZ75-BS	0012500		YTZ75-BS	
HYOSUNG	WRE/SM	125	04-05	RHTX4L-BS	0012310	ETX4L-BS	YTX4L-BS	
	Avanti, Challenger, Racing, Rush	50	-	RHB4L-B	0012180	EB4L-B	YB4L-B	
	EZ 100	100	05	RHTX5L-BS	0012380	ETX5L-BS	YTX5L-BS	
	GT125 Comet	125	09-10	RHTX7A-BS	0012350	ETX7A-BS	YTX7A-BS	
	GT250, R	250	09-10	RHTX14-BS	0012390	ETX14-BS	YTX14-BS	
	GT650, R, S	650	09-10	RHTX14-BS	0012390	ETX14-BS	YTX14-BS	
	GV250	250	09-10	RHTX9-BS	0012330	ETX9-BS	YTX9-BS	
	GV650, SE	650	09-10	RHT14B-BS				
	NS3-250	250	09-10	RHTX9-BS	0012330	ETX9-BS	YTX9-BS	
	ST7	700	10-	RHT14B-BS				
	Super Cub, Sense, Prima, Rally	50	-	RHTX4L-BS	0012310	ETX4L-BS	YTX4L-BS	
	XRX	125	-	RHTX7A-BS	0012350	ETX7A-BS	YTX7A-BS	
	ITALJET	Adly	50	-	RHB5L-B	0012240	EB5L-B	YB5L-B
Bazooka, 2		50	-	RHB4L-B	0012180	EB4L-B	YB4L-B	
Cruise		50	-	RHB4L-B	0012180	EB4L-B	YB4L-B	
Dragster		50	97	RHB4L-B	0012180	EB4L-B	YB4L-B	
Dragster		125	99	RHB10L-B-P	0012480	EB10L-B	YB10L-B	
Dragster		180	99	RHB10L-B-P	0012480	EB10L-B	YB10L-B	
Formula		50	95-97	RHB4L-B	0012180	EB4L-B	YB4L-B	
Formula		125	97-	RHB9-B		EB9-B	YB9-B	
Formular		50	97-	RHB4L-B	0012180	EB4L-B	YB4L-B	
Jet Set		50	01-03	RHB4L-B	0012180	EB4L-B	YB4L-B	
Juppiter		250	01-03	RHTX9-BS	0012330	ETX9-BS	YTX9-BS	
Millenium		125	00-03	RHTX7A-BS	0012350	ETX7A-BS	YTX7A-BS	
Millenium		150	00-02	RHTX7A-BS	0012350	ETX7A-BS	YTX7A-BS	
Pista		50	80-95	RHB4L-B	0012180	EB4L-B	YB4L-B	
Reporter		50	-	RHB4L-B	0012180	EB4L-B	YB4L-B	
Scoop		50	-	RHB4L-B	0012180	EB4L-B	YB4L-B	
Techno Air		50	-	RHB4L-B	0012180	EB4L-B	YB4L-B	
Torpedo		50	97-03	RHB4L-B	0012180	EB4L-B	YB4L-B	
Torpedo		125	99	RHB9-B		EB9-B	YB9-B	
Torpedo		150	00-03	RHB9-B		EB9-B	YB9-B	
Velocifero		50	93-99	RHB4L-B	0012180	EB4L-B	YB4L-B	
KAWASAKI		250TR (BJ250F)	250	02-	RHTX7L-BS	0012430	ETX7L-BS	YTX7L-BS
		A1 Series	250	66-71	RHB9-B		EB9-B	YB9-B
		A7 Series	350	66-71	RHB9-B		EB9-B	YB9-B
		BN Eliminator	125	01-10	RHB9-B		EB9-B	YB9-B
		BN125	125	01-07	RHB9-B		EB9-B	YB9-B
	BN125 A1-A2 Eliminator	125	97-07	RHB9-B		EB9-B	YB9-B	
	Concours	1400	14-	RHTZ14S-BS	0012580		YTZ14S-BS	
	D-TRACKER (LX250E)	250	02-	RHTX7L-BS	0012430	ETX7L-BS	YTX7L-BS	
	EJ650	650	99-00	RHTX14-BS	0012390	ETX14-BS	YTX14-BS	
	EJ650A, C	650	04	RHTX12-BS	0012320	ETX12-BS	YTX12-BS	
	EJ650A, C	650	02-03	RHTX14-BS	0012390	ETX14-BS	YTX14-BS	
	EL250 A	250	95	RHTX7L-BS	0012430	ETX7L-BS	YTX7L-BS	
	ER 6F/6N	650	06-10	RHTX12-BS	0012320	ETX12-BS	YTX12-BS	
	ER-6n	650	12	RHTX12-BS	0012320	ETX12-BS	YTX12-BS	
	ER5 (ER500A, B, C)	500	97-	RHTX12-BS	0012320	ETX12-BS	YTX12-BS	

BATTERIE MOTO - ATV, UTV - MARINE

MARCA	MODELLO	CC	ANNO	BATTERIA RHIAG	BATTERIA MPT	BATTERIA EXIDE	BATTERIA YUASA
MAKE	MODEL	CC	YEAR	RHIAG BATTERY	MOTORPARTS BATTERY	EXIDE BATTERY	YUASA BATTERY
KAWASAKI	ER5 (ER500A, B)	500	97-	RHTX12-BS	0012320	ETX12-BS	YTX12-BS
	ER525KW	500	97-01	RHTX12-BS	0012320	ETX12-BS	YTX12-BS
	ER537KW	500	97-01	RHTX12-BS	0012320	ETX12-BS	YTX12-BS
	ER6 N	650	09-11	RHTX12-BS	0012320	ETX12-BS	YTX12-BS
	ER6 N	650	12-	RHT12B-BS	0012550	ET12B-BS	YT12B-BS
	ER650-A, B	650	06	RHTX12-BS	0012320	ETX12-BS	YTX12-BS
	Estrella - BJ250 A2-A3 C2-C3	250	92-	RHTX9-BS	0012330	ETX9-BS	YTX9-BS
	EX250 Ninja	250	95-07	RHTX7L-BS	0012430	ETX7L-BS	YTX7L-BS
	EX250 Ninja 250R	250	12	RHTX7A-BS	0012350	ETX7A-BS	YTX7A-BS
	EX250 Ninja 250R	250	08-11	RHTX7L-BS	0012430	ETX7L-BS	YTX7L-BS
	EX250-F Ninja	250	95-07	RHTX7L-BS	0012430	ETX7L-BS	YTX7L-BS
	EX250, Ninja 250R	250	08-10	RHTX7A-BS	0012350	ETX7A-BS	YTX7A-BS
	EX300 Ninja	300	13-	RHTX9-BS	0012330	ETX9-BS	YTX9-BS
	EX650-A, B	650	06	RHTX12-BS	0012320	ETX12-BS	YTX12-BS
	GPZ1100 (ZXT10, E, F)	1100	95-97	RHTX14-BS	0012390	ETX14-BS	YTX14-BS
	GPZ250R EX250 F9-F13	250	95-	RHTX7L-BS	0012430	ETX7L-BS	YTX7L-BS
	GPZ250R EX250 H5-H9	250	95-	RHTX7L-BS	0012430	ETX7L-BS	YTX7L-BS
	GTR	1400	08	RHTZ14S-BS	0012580		YTZ14S-BS
	H1 Series	500	69-72	RHB9-B		EB9-B	YB9-B
	JT-A, C STX-15F	1500	04-05	RHTX20L-BS	0012640		YTX20L-BS
	KL250 D2-D16	250	-	RHB4L-B	0012180	EB4L-B	YB4L-B
	KL250 Super Sherpa	250	09-10	RHTX7L-BS	0012430	ETX7L-BS	YTX7L-BS
	KL250 Super Sherpa	250	00-04	RHTX7L-BS	0012430	ETX7L-BS	YTX7L-BS
	KL250G, H Super Sherpa	250	97-10	RHTX7L-BS	0012430	ETX7L-BS	YTX7L-BS
	KL600A KLR (Kick-Starter)	600	89-90	RHB4L-B	0012180	EB4L-B	YB4L-B
	KLE Versys	650	07-10	RHTX12-BS	0012320	ETX12-BS	YTX12-BS
	KLE250 Anhele (LE250A)	250	-97	RHTX7L-BS	0012430	ETX7L-BS	YTX7L-BS
	KLE400 (LE400A)	400	91-	RHTX12-BS	0012320	ETX12-BS	YTX12-BS
	KLE500 (LE500)	500	91-07	RHTX12-BS	0012320	ETX12-BS	YTX12-BS
	KLE650 Versys	650	08-14	RHTX12-BS	0012320	ETX12-BS	YTX12-BS
	KLX	1000	04-05	RHTX14-BS	0012390	ETX14-BS	YTX14-BS
	KLX R	450	08-10	RHTZ7S-BS	0012500		YTZ7S-BS
	KLX, KLX D-Tracker	125	10-	RHTX7L-BS	0012430	ETX7L-BS	YTX7L-BS
	KLX250ES G1/G2	250	94-95	RHTX7L-BS	0012430	ETX7L-BS	YTX7L-BS
	KLX250S	250	06-10	RHTX7L-BS	0012430	ETX7L-BS	YTX7L-BS
	KLX400R, KLX400SR	400	03-04	RHT7B-BS	0012520	ET7B-BS	YT7B-BS
	KLX450R	450	08-10	RHTZ7S-BS	0012500		YTZ7S-BS
	KLX650 (LX650C)	650	93-97	RHTX9-BS	0012330	ETX9-BS	YTX9-BS
	KLX650C, R	650	93-96	RHTX9-BS	0012330	ETX9-BS	YTX9-BS
	KLZ	1000	12-	RHTX9-BS	0012330	ETX9-BS	YTX9-BS
	KMX125 A1-A8, A11	125	86-	RHB4L-B	0012180	EB4L-B	YB4L-B
	KMX125 B1-B9	125	91-	RHB4L-B	0012180	EB4L-B	YB4L-B
	KMX200 A2-A5	200	-97	RHB4L-B	0012180	EB4L-B	YB4L-B
	KR250 B, C, KR, 1S	250	-92	RHB4L-B	0012180	EB4L-B	YB4L-B
	KSR110	100	05-	RHTX4L-BS	0012310	ETX4L-BS	YTX4L-BS
	KX1100-E (GPz1100), ABS	1100	95-97	RHTX14-BS	0012390	ETX14-BS	YTX14-BS
	KZ1000 LTD K	1000	81-83	RHTX20L-BS	0012640		YTX20L-BS
KZ1000 R SS	1000	81-83	RHTX20L-BS	0012640		YTX20L-BS	
KZ1000-P Police	1000	02-05	RHTX20L-BS	0012640		YTX20L-BS	
KZ1000-R Replica	1000	82-83	RHTX20L-BS	0012640		YTX20L-BS	
KZ1000, LTD, CSR	1000	81-83	RHTX20L-BS	0012640		YTX20L-BS	

MARCA	MODELLO	CC	ANNO	BATTERIA RHIAG	BATTERIA MPT	BATTERIA EXIDE	BATTERIA YUASA
MAKE	MODEL	CC	YEAR	RHIAG BATTERY	MOTORPARTS BATTERY	EXIDE BATTERY	YUASA BATTERY
KAWASAKI	KZ1000J, M CSR	1000	81-83	RHTX20L-BS	0012640		YTX20L-BS
	KZ1000P Police	1000	82-01	RHTX20L-BS	0012640		YTX20L-BS
	KZ1100A	1100	81-83	RHTX20L-BS	0012640		YTX20L-BS
	KZ1100L LTD	1100	81-83	RHTX20L-BS	0012640		YTX20L-BS
	KZ200 A	200	95	RHB10L-B-P	0012480	EB10L-B	YB10L-B
	KZ200 A	200	77-79	RHB10L-B-P	0012480	EB10L-B	YB10L-B
	KZ200 A, C	200	-92	RHB10L-B-P	0012480	EB10L-B	YB10L-B
	KZ750-L Ninja K	750	93	RHTX9-BS	0012330	ETX9-BS	YTX9-BS
	Ninja 1000, ABS	1000	14-	RHT12A-BS	0012470	ET12A-BS	YT12A-BS
	Ninja 650R	650	06-10	RHTX12-BS	0012320	ETX12-BS	YTX12-BS
	Ninja ZX-14	1400	06-10	RHTX14-BS	0012390	ETX14-BS	YTX14-BS
	Versys 1000	1050	12-	RHTX9-BS	0012330	ETX9-BS	YTX9-BS
	VLE500A	550	91	RHTX12-BS	0012320	ETX12-BS	YTX12-BS
	VN Classic	900	06-08	RHTX12-BS	0012320	ETX12-BS	YTX12-BS
	VN Classic Tourer	1500	00-03	RHTX20L-BS	0012640		YTX20L-BS
	VN Classic Tourer	1500	98-99	RHTX20L-BS	0012640		YTX20L-BS
	VN Drifter	1500	99-00	RHTX20L-BS	0012640		YTX20L-BS
	VN400A, C Vulcan	400	95-	RHTX12-BS	0012320	ETX12-BS	YTX12-BS
	VN800 A	800	96-03	RHTX14-BS	0012390	ETX14-BS	YTX14-BS
	VN800 C	800	99-03	RHTX14-BS	0012390	ETX14-BS	YTX14-BS
	VN800 Classic B	800	96-03	RHTX14-BS	0012390	ETX14-BS	YTX14-BS
	VN800 D	800	99-02	RHTX14-BS	0012390	ETX14-BS	YTX14-BS
	VN800-A,B,C, E Vulcan, Classic, Drifter	800	95-03	RHTX14-BS	0012390	ETX14-BS	YTX14-BS
	VN800-A,B,E Vulcan, Classic, Drifter	800	04-06	RHTX12-BS	0012320	ETX12-BS	YTX12-BS
	VN900, B, C, D	900	06	RHTX12-BS	0012320	ETX12-BS	YTX12-BS
	Vulcan 900 Classic	900	06-10	RHTX12-BS	0012320	ETX12-BS	YTX12-BS
	W 650	650	-	RHTX14-BS	0012390	ETX14-BS	YTX14-BS
	W800	800	11-	RHTX12-BS	0012320	ETX12-BS	YTX12-BS
	Z 750	750	04-05	RHTX12-BS	0012320	ETX12-BS	YTX12-BS
	Z1000	1000	03-10	RHTX9-BS	0012330	ETX9-BS	YTX9-BS
	Z1000 SX	1000	11-	RHTX9-BS	0012330	ETX9-BS	YTX9-BS
	Z1000, ABS	1000	14-	RHT12A-BS	0012470	ET12A-BS	YT12A-BS
	Z750	750	04-08	RHTX9-BS	0012330	ETX9-BS	YTX9-BS
	Z750 (EU)	750	09-10	RHTX9-BS	0012330	ETX9-BS	YTX9-BS
	Z750R	750	12	RHTX9-BS	0012330	ETX9-BS	YTX9-BS
	ZG 1400 Concours	1400	08-10	RHTX14-BS	0012390	ETX14-BS	YTX14-BS
	ZG1000A Concours	1000	86-06	RHTX20L-BS	0012640		YTX20L-BS
	ZR-7, S	750	00-03	RHTX12-BS	0012320	ETX12-BS	YTX12-BS
	ZR250A, B Balius	250	91-	RHTX7L-BS	0012430	ETX7L-BS	YTX7L-BS
	ZR400C, G Zephyr	400	93-	RHTX12-BS	0012320	ETX12-BS	YTX12-BS
	ZR400D Xanthus	400	92-	RHTX9-BS	0012330	ETX9-BS	YTX9-BS
	ZR550B Zephyr	550	94-97	RHTX12-BS	0012320	ETX12-BS	YTX12-BS
	ZR750 (Z750S)	750	05-06	RHTX9-BS	0012330	ETX9-BS	YTX9-BS
	ZR750C, D Zephyr F	750	91-03	RHTX12-BS	0012320	ETX12-BS	YTX12-BS
	ZRX S	1200	04	RHTX14-BS	0012390	ETX14-BS	YTX14-BS
	ZRX S	1200	01-03	RHTX14-BS	0012390	ETX14-BS	YTX14-BS
	ZRX, -II (ZR400E, F, D)	400	95-	RHTX9-BS	0012330	ETX9-BS	YTX9-BS
	ZRX, R	1200	01-05	RHTX14-BS	0012390	ETX14-BS	YTX14-BS
	ZRX1100/II (ZRT10C, D)	1100	97-00	RHTX14-BS	0012390	ETX14-BS	YTX14-BS
	ZRX1200 DAEG	1200	09-10	RHTX12-BS	0012320	ETX12-BS	YTX12-BS
ZRX1200R/S (ZRT20A/B)	1200	01-	RHTX14-BS	0012390	ETX14-BS	YTX14-BS	

BATTERIE MOTO - ATV, UTV - MARINE

MARCA	MODELLO	CC	ANNO	BATTERIA RHIAG	BATTERIA MPT	BATTERIA EXIDE	BATTERIA YUASA
MAKE	MODEL	CC	YEAR	RHIAG BATTERY	MOTORPARTS BATTERY	EXIDE BATTERY	YUASA BATTERY
KAWASAKI	ZS 750	750	05	RHTX12-BS	0012320	ETX12-BS	YTX12-BS
	ZX 10 R NINJA	1000	04-10	RHT12B-BS	0012550	ET12B-BS	YT12B-BS
	ZX-11(ZX1100D1) Ninja	1100	93-01	RHTX14-BS	0012390	ETX14-BS	YTX14-BS
	ZX-1200A1	1200	00-	RHTX14-BS	0012390	ETX14-BS	YTX14-BS
	ZX-12R(ZXT20B)	1200	00-05	RHTX14-BS	0012390	ETX14-BS	YTX14-BS
	ZX-6R	600	12	RHTX9-BS	0012330	ETX9-BS	YTX9-BS
	ZX-6R Ninja	600	98-10	RHTX9-BS	0012330	ETX9-BS	YTX9-BS
	ZX-6R Ninja	636	13-	RHTX9-BS	0012330	ETX9-BS	YTX9-BS
	ZX-7R Ninja	750	96-02	RHTX12-BS	0012320	ETX12-BS	YTX12-BS
	ZX-7R-7RR Ninja	750	91-96	RHTX9-BS	0012330	ETX9-BS	YTX9-BS
	ZX-7RR Ninja	750	96-97	RHTX9-BS	0012330	ETX9-BS	YTX9-BS
	ZX-9R (ZX900B) Ninja	900	94-97	RHTX12-BS	0012320	ETX12-BS	YTX12-BS
	ZX-9R (ZX900C, D) Ninja	900	98-99	RHTX9-BS	0012330	ETX9-BS	YTX9-BS
	ZX-9R (ZX900E, F) Ninja	900	00-03	RHTX9-BS	0012330	ETX9-BS	YTX9-BS
	ZX10 R Ninja	1000	04-10	RHT12B-BS	0012550	ET12B-BS	YT12B-BS
	ZX10 R Ninja	1000	11-	RHTZ75-BS	0012500		YTZ75-BS
	ZX1000-C Ninja (ZX-10R)	1000	04-10	RHT12B-BS	0012550	ET12B-BS	YT12B-BS
	ZX1000-C Ninja ZX-10R	1000	04-09	RHT12B-BS	0012550	ET12B-BS	YT12B-BS
	ZX1000A Concours	1000	96-02	RHTX20L-BS	0012640		YTX20L-BS
	ZX10R ABS	1000	11-	RHTZ10S-BS	0012540		YTZ10S-BS
	ZX1100 C-G	1100	99	RHTX14-BS	0012390	ETX14-BS	YTX14-BS
	ZX1100 D1	1100	94	RHTX14-BS	0012390	ETX14-BS	YTX14-BS
	ZX1100-D Ninja ZX-11	1100	95-01	RHTX14-BS	0012390	ETX14-BS	YTX14-BS
	ZX1100-D Ninja ZX-11 (CN)	1100	93-94	RHTX14-BS	0012390	ETX14-BS	YTX14-BS
	ZX1100-E (GPz1100), ABS	1100	95-97	RHTX14-BS	0012390	ETX14-BS	YTX14-BS
	ZX600 G/H/R	600	95-97	RHTX12-BS	0012320	ETX12-BS	YTX12-BS
	ZX600-E, F Ninja ZX-6, 6R	600	93-02	RHTX12-BS	0012320	ETX12-BS	YTX12-BS
	ZX600-G, J ZX-6R	600	98-08	RHTX9-BS	0012330	ETX9-BS	YTX9-BS
	ZX600-K, M, N ZX-6RR	600	03-06	RHTX9-BS	0012330	ETX9-BS	YTX9-BS
	ZX600F ZX-6R Ninja	600	95-98	RHTX12-BS	0012320	ETX12-BS	YTX12-BS
	ZX636-B, C Ninja ZX-6R	636	02-06	RHTX9-BS	0012330	ETX9-BS	YTX9-BS
	ZX6R-ZZR	600	05	RHTX9-BS	0012330	ETX9-BS	YTX9-BS
	ZX750 Ninja ZX, 7RR	750	91-97	RHTX9-BS	0012330	ETX9-BS	YTX9-BS
	ZX750-H Ninja ZX-7	750	90	RHB12AL-A	0012340	EB12AL-A	YB12AL-A
	ZX750-J Ninja ZX-7	750	91-95	RHTX12-BS	0012320	ETX12-BS	YTX12-BS
	ZX750-JI	750	91	RHB12AL-A	0012340	EB12AL-A	YB12AL-A
	ZX750-L ZX-7	750	93-94	RHTX9-BS	0012330	ETX9-BS	YTX9-BS
	ZX750-P Ninja ZX-7R	750	96-03	RHTX12-BS	0012320	ETX12-BS	YTX12-BS
	ZX900-B Ninja (ZX-9R)	900	94-97	RHTX12-BS	0012320	ETX12-BS	YTX12-BS
	ZX900-C Ninja (ZX-9R)	900	98-99	RHTX9-BS	0012330	ETX9-BS	YTX9-BS
	ZX900-E, F Ninja (ZX-9R)	900	00-03	RHTX9-BS	0012330	ETX9-BS	YTX9-BS
	ZXR1100	1100	99-00	RHTX14-BS	0012390	ETX14-BS	YTX14-BS
	ZXR1100 C	1100	97	RHTX14-BS	0012390	ETX14-BS	YTX14-BS
	ZXR400, R (ZX400M, L)	400	91-	RHTX9-BS	0012330	ETX9-BS	YTX9-BS
	ZXR750 (ZX750L)	750	91-	RHTX12-BS	0012320	ETX12-BS	YTX12-BS
	ZXR750, R (ZX750J)	750	91-	RHTX12-BS	0012320	ETX12-BS	YTX12-BS
	ZXR750R (ZX750K, M)	750	91-	RHTX9-BS	0012330	ETX9-BS	YTX9-BS
ZZ-R (EX250H)	250	94-	RHTX7L-BS	0012430	ETX7L-BS	YTX7L-BS	
ZZ-R400 (ZX400N)	400	93-	RHTX12-BS	0012320	ETX12-BS	YTX12-BS	
ZZ-R500 Ninja (ZX500D)	550	-98	RHTX12-BS	0012320	ETX12-BS	YTX12-BS	
ZZR	600	93-02	RHTX12-BS	0012320	ETX12-BS	YTX12-BS	

MARCA	MODELLO	CC	ANNO	BATTERIA RHIAG	BATTERIA MPT	BATTERIA EXIDE	BATTERIA YUASA	
MAKE	MODEL	CC	YEAR	RHIAG BATTERY	MOTORPARTS BATTERY	EXIDE BATTERY	YUASA BATTERY	
KAWASAKI	ZZR	1200	02-05	RHTX14-BS	0012390	ETX14-BS	YTX14-BS	
	ZZR	1400	06-08	RHTZ14S-BS	0012580		YTZ14S-BS	
	ZZR1000EU (ZXT10D)	1100	93-	RHTX14-BS	0012390	ETX14-BS	YTX14-BS	
	ZZR600	600	02-04	RHTX12-BS	0012320	ETX12-BS	YTX12-BS	
	ZZR600	600	05-09	RHTX9-BS	0012330	ETX9-BS	YTX9-BS	
	ZZR600	600	98-02	RHTX9-BS	0012330	ETX9-BS	YTX9-BS	
	KTM	125LC2	125	96-97	RHTX4L-BS	0012310	ETX4L-BS	YTX4L-BS
		250 EXC Six Days	250	12	RHTX4L-BS	0012310	ETX4L-BS	YTX4L-BS
		300 EXC Six Days	300	12	RHTX4L-BS	0012310	ETX4L-BS	YTX4L-BS
		450EXC, six-days	450	12	RHTX5L-BS	0012380	ETX5L-BS	YTX5L-BS
500K4,LC		500	-	RHB9-B		EB9-B	YB9-B	
80 Chopper, PL		80	-	RHB9-B		EB9-B	YB9-B	
Adventure		620	96-98	RHTX9-BS	0012330	ETX9-BS	YTX9-BS	
Adventure		640	03-05	RHTZ10S-BS	0012540		YTZ10S-BS	
Adventure		950	03-14	RHTZ14S-BS	0012580		YTZ14S-BS	
Adventure ABS, Adventure R ABS		1190	13-	RHTZ14S-BS	0012580		YTZ14S-BS	
Adventure R		625	00-	RHTX9-BS	0012330	ETX9-BS	YTX9-BS	
Adventure, S		990	03-	RHTZ14S-BS	0012580		YTZ14S-BS	
Adventurer		640	99-02	RHTX9-BS	0012330	ETX9-BS	YTX9-BS	
Adventurer, Duke, RXC LC4 Super Moto		640	99-02	RHTX9-BS	0012330	ETX9-BS	YTX9-BS	
All SM		625	03-	RHTZ10S-BS	0012540		YTZ10S-BS	
Chopper, PL, RLW, RSL		80	-	RHB9-B		EB9-B	YB9-B	
Duke		125	11	RHT7B-BS	0012520	ET7B-BS	YT7B-BS	
Duke		125	13-	RHTX7L-BS	0012430	ETX7L-BS	YTX7L-BS	
Duke		200	12	RHT7B-BS	0012520	ET7B-BS	YT7B-BS	
Duke		200	13-	RHTX9-BS	0012330	ETX9-BS	YTX9-BS	
Duke		390	13-	RHTX9-BS	0012330	ETX9-BS	YTX9-BS	
Duke		620	96-98	RHTX9-BS	0012330	ETX9-BS	YTX9-BS	
Duke E		620	96-98	RHTX9-BS	0012330	ETX9-BS	YTX9-BS	
Duke II		640	03-05	RHTZ10S-BS	0012540		YTZ10S-BS	
Duke II		640	99-02	RHTX9-BS	0012330	ETX9-BS	YTX9-BS	
Duke II Schwarz, LC4, Adventure		640	03-	RHTZ10S-BS	0012540		YTZ10S-BS	
Duke, E		640	96-97	RHTX9-BS	0012330	ETX9-BS	YTX9-BS	
Duke, RXC LC4		950	03-07	RHTZ14S-BS	0012580		YTZ14S-BS	
Duke, Supermoto		690	09-10	RHTZ10S-BS	0012540		YTZ10S-BS	
E/XC Racing 4-Stroke (Opt)		400	00-02	RHTX5L-BS	0012380	ETX5L-BS	YTX5L-BS	
E/XC, M/XC Racing 4Stroke		520	00-02	RHTX4L-BS	0012310	ETX4L-BS	YTX4L-BS	
E/XC, M/XC Racing 4Stroke (opt)		520	00-02	RHTZ7S-BS/RHTX5L-BS	0012380	ETX5L-BS	YTX5L-BS	
E/XC520 Racing 4S		520	00-02	RHTX4L-BS	0012310	ETX4L-BS	YTX4L-BS	
ECX-F			05-	RHTX5L-BS	0012380	ETX5L-BS	YTX5L-BS	
Euduo		690	-	RHTZ10S-BS	0012540		YTZ10S-BS	
EXC		250	05-10	RHTX5L-BS/RHTZ7S-BS	0012380	ETX5L-BS	YTX5L-BS	
EXC	400	00-02	RHTX5L-BS/RHTZ7S-BS	0012380	ETX5L-BS	YTX5L-BS		
EXC Racing	250	05-10	RHTX5L-BS	0012380	ETX5L-BS	YTX5L-BS		
EXC Racing 4-stroke	400	00-02	CTZ5S-BS/RHTX4L-BS	0012310	ETX4L-BS	YTX4L-BS		
EXC-F	250	05-	RHTX5L-BS	0012380	ETX5L-BS	YTX5L-BS		
EXC-F	300	-	RHTX4L-BS	0012310	ETX4L-BS	YTX4L-BS		
EXC, Racing	530	05-09	RHTZ7S-BS/RHTX5L-BS	0012380	ETX5L-BS	YTX5L-BS		
EXC, Six-Days	500	12-	RHTX5L-BS/RHB9-B	0012380	ETX5L-BS/EB9-B	YTX5L-BS/YB9-B		
EXF	250	05-10	RHTZ7S-BS/RHTX5L-BS	0012380	ETX5L-BS	YTX5L-BS		
Freeride 350	350	11-	RHTX5L-BS	0012380	ETX5L-BS	YTX5L-BS		

BATTERIE MOTO - ATV, UTV - MARINE

MARCA MAKE	MODELLO MODEL	CC CC	ANNO YEAR	BATTERIA RHIAG RHIAG BATTERY	BATTERIA MPT MOTORPARTS BATTERY	BATTERIA EXIDE EXIDE BATTERY	BATTERIA YUASA YUASA BATTERY
KTM	GO,Go Chrono	50	95-	RHTX4L-BS	0012310	ETX4L-BS	YTX4L-BS
	Kross	50	-	RHB4L-B	0012180	EB4L-B	YB4L-B
	LC4	400	98	RHTX9-BS	0012330	ETX9-BS	YTX9-BS
	LC4	640	03-05	RHTZ10S-BS	0012540		YTZ10S-BS
	LC4 Supercomp.	620	96-98	RHTX9-BS	0012330	ETX9-BS	YTX9-BS
	LC4-E	400	97	RHTX9-BS	0012330	ETX9-BS	YTX9-BS
	LC4-E, LC4 Supermotard	640	99-02	RHTX9-BS	0012330	ETX9-BS	YTX9-BS
	LS-E	400	97	RHTX9-BS	0012330	ETX9-BS	YTX9-BS
	LS-E	620	97	RHTX9-BS	0012330	ETX9-BS	YTX9-BS
	MX Desert Racing	525	03	RHTZ7S-BS/RHTX5L-BS	0012380	ETX5L-BS	YTX5L-BS
	MXC	400	-	RHTX5L-BS	0012380	ETX5L-BS	YTX5L-BS
	MXC Racing	450	00-02	RHTX5L-BS	0012380	ETX5L-BS	YTX5L-BS
	MXC Racing	525	03	RHTZ7S-BS/RHTX5L-BS	0012380	ETX5L-BS	YTX5L-BS
	RC8	1090	09-10	RHTZ14S-BS	0012580		YTZ14S-BS
	RC8 Track , RC8 R	1190	08-	RHTZ14S-BS	0012580		YTZ14S-BS
	RXC LC4	400	96-01	RHTX9-BS	0012330	ETX9-BS	YTX9-BS
	SMC	625	03-09	RHTZ10S-BS	0012540		YTZ10S-BS
	SMR	450	08-	RHTX4L-BS	0012310	ETX4L-BS	YTX4L-BS
	Sting	125	97-98	RHTX4L-BS	0012310	ETX4L-BS	YTX4L-BS
	Super Duke, Adventure	990	03-10	RHTZ14S-BS	0012580		YTZ14S-BS
	Supercromo	625	98	RHTX9-BS	0012330	ETX9-BS	YTX9-BS
	Superenduro	990	09	RHTZ14S-BS	0012580		YTZ14S-BS
	Supermoto	640	03-05	RHTZ10S-BS	0012540		YTZ10S-BS
	Supermoto	950	03-10	RHTZ14S-BS	0012580		YTZ14S-BS
	Supermoto	990	09-10	RHTZ14S-BS	0012580		YTZ14S-BS
	SX-F	250	12-	RHTX4L-BS	0012310	ETX4L-BS	YTX4L-BS
	SX-F	350	11-	RHTX4L-BS	0012310	ETX4L-BS	YTX4L-BS
	SX-F	450	11-	RHTX4L-BS	0012310	ETX4L-BS	YTX4L-BS
	SX-F, XG-F, XC-W	450	09-10	RHTX5L-BS	0012380	ETX5L-BS	YTX5L-BS
	SXC	625	03-09	RHTZ10S-BS	0012540		YTZ10S-BS
	XC	250	11-	RHTX4L-BS	0012310	ETX4L-BS	YTX4L-BS
	XC	300	11-	RHTX4L-BS	0012310	ETX4L-BS	YTX4L-BS
	XC-F	250	-	RHTX5L-BS	0012380	ETX5L-BS	YTX5L-BS
XC-F	350	11-	RHTX5L-BS	0012380	ETX5L-BS	YTX5L-BS	
XC-W	400	09-10	RHTZ7S-BS/RHTX5L-BS	0012380	ETX5L-BS	YTX5L-BS	
XC-W	530	09-10	RHTZ7S-BS/RHTX5L-BS	0012380	ETX5L-BS	YTX5L-BS	
KYMCO	Agility	50	09-10	RHTX7A-BS	0012350	ETX7A-BS	YTX7A-BS
	Agility	125	06-08	RHTX7A-BS	0012350	ETX7A-BS	YTX7A-BS
	Agility	180	10-	RHTX9-BS	0012330	ETX9-BS	YTX9-BS
	Agility RS Naked	50	10-	RHTX7A-BS	0012350	ETX7A-BS	YTX7A-BS
	Agility125	125	11-	RHTX5L-BS	0012380	ETX5L-BS	YTX5L-BS
	AS100	100	99	RHTX5L-BS	0012380	ETX5L-BS	YTX5L-BS
	B & W 125	125	99	RHTX9-BS	0012330	ETX9-BS	YTX9-BS
	B&W 150	150	-	RHTX9-BS	0012330	ETX9-BS	YTX9-BS
	B&W 250	250	01-	RHTX12-BS	0012320	ETX12-BS	YTX12-BS
	B&W 250	250	02-	RHTX12-BS	0012320	ETX12-BS	YTX12-BS
	B&W 50	50	-	RHTX5L-BS	0012380	ETX5L-BS	YTX5L-BS
	Calypso 125	125	99	RHTX9-BS	0012330	ETX9-BS	YTX9-BS
	Calypso 50, Cobra, Cross	50	99	RHTX5L-BS	0012380	ETX5L-BS	YTX5L-BS
	Caro 100	100	-	RHTX7A-BS	0012350	ETX7A-BS	YTX7A-BS
	Cherry 100	100	-	RHTX5L-BS	0012380	ETX5L-BS	YTX5L-BS

MARCA	MODELLO	CC	ANNO	BATTERIA RHIAG	BATTERIA MPT	BATTERIA EXIDE	BATTERIA YUASA
MAKE	MODEL	CC	YEAR	RHIAG BATTERY	MOTORPARTS BATTERY	EXIDE BATTERY	YUASA BATTERY
KYMCO	Cherry 100 Fi	100	11-	RHTX7A-BS	0012350	ETX7A-BS	YTX7A-BS
	Cherry 50	50	-	RHTX5L-BS	0012380	ETX5L-BS	YTX5L-BS
	Cobra	100	-	RHTX5L-BS	0012380	ETX5L-BS	YTX5L-BS
	CX/CX Super	50	00-	RHTX4L-BS	0012310	ETX4L-BS	YTX4L-BS
	CX50, -Curio, -Super	50	95-97	RHTX4L-BS	0012310	ETX4L-BS	YTX4L-BS
	Dink	150	-	RHTX9-BS	0012330	ETX9-BS	YTX9-BS
	Dink	200	04	RHTX9-BS	0012330	ETX9-BS	YTX9-BS
	Dink 180 Fi	180	-	RHTZ12S-BS		ELTZ14S	YTZ12-S
	Dink 180i	180	-	RHTX12-BS	0012320	ETX12-BS	YTX12-BS
	Dink 250	250	-	RHTX12-BS	0012320	ETX12-BS	YTX12-BS
	Dink 50	50	99	RHTX5L-BS	0012380	ETX5L-BS	YTX5L-BS
	Dink Euro3	200	06-07	RHTX12-BS	0012320	ETX12-BS	YTX12-BS
	Dink II	50	-	RHTX5L-BS	0012380	ETX5L-BS	YTX5L-BS
	Dink II	125	-	RHTX9-BS	0012330	ETX9-BS	YTX9-BS
	Dink LX	125	97	RHTX9-BS	0012330	ETX9-BS	YTX9-BS
	Dink LX	150	97	RHTX9-BS	0012330	ETX9-BS	YTX9-BS
	Dink Street 300	300	10-	RHTX12-BS	0012320	ETX12-BS	YTX12-BS
	Dj 50,Djw 50, Djx 50	50	97	RHTX4L-BS	0012310	ETX4L-BS	YTX4L-BS
	Dj 50,Djw 50, Djx 50	50	98-	RHTX4L-BS	0012310	ETX4L-BS	YTX4L-BS
	Downtown	125	-	RHT12A-BS	0012470	ET12A-BS	YT12A-BS
	Downtown	300	10-	RHT12A-BS	0012470	ET12A-BS	YT12A-BS
	Downtown i	200	10-	RHT12A-BS	0012470	ET12A-BS	YT12A-BS
	Easy 100	100	-	RHTX5L-BS	0012380	ETX5L-BS	YTX5L-BS
	Easy 100 Fi	100	-	RHTX7A-BS	0012350	ETX7A-BS	YTX7A-BS
	EGO 150	150	-	RHTX9-BS	0012330	ETX9-BS	YTX9-BS
	EGO 250	250	-	RHTX12-BS	0012320	ETX12-BS	YTX12-BS
	Fever ZX	50	00-	RHTX4L-BS	0012310	ETX4L-BS	YTX4L-BS
	Filly 50	50	99	RHTX5L-BS	0012380	ETX5L-BS	YTX5L-BS
	Filly 80	80	99	RHTX5L-BS	0012380	ETX5L-BS	YTX5L-BS
	Fox Hunt	125	96	RHTX7L-BS	0012430	ETX7L-BS	YTX7L-BS
	Fox Hunt	150	96	RHTX7L-BS	0012430	ETX7L-BS	YTX7L-BS
	G5 125	125	-	RHTX9-BS	0012330	ETX9-BS	YTX9-BS
	G5 125 Fi	125	11-	RHTX9-BS	0012330	ETX9-BS	YTX9-BS
	G5 150	150	-	RHTX9-BS	0012330	ETX9-BS	YTX9-BS
	G5 150 Fi	150	-	RHTX9-BS	0012330	ETX9-BS	YTX9-BS
	GP 125	125	-	RHTX7A-BS	0012350	ETX7A-BS	YTX7A-BS
	Grand Dink	50	-	RHTX4L-BS	0012310	ETX4L-BS	YTX4L-BS
	Grand Dink	125	08-	RHTX9-BS	0012330	ETX9-BS	YTX9-BS
	Grand Dink	150	-	RHTX9-BS	0012330	ETX9-BS	YTX9-BS
	Grand Dink	250	-	RHTX12-BS	0012320	ETX12-BS	YTX12-BS
	Grand Dink	300	12-	RHT12B-BS	0012550	ET12B-BS	YT12B-BS
	Grand King 125 Fi	125	-	RHT9B-BS	0012530	ET9B-BS	YT9B-BS
	Heroism	50	95-97	RHTX4L-BS	0012310	ETX4L-BS	YTX4L-BS
	Heroism	125	95-96	RHTX9-BS	0012330	ETX9-BS	YTX9-BS
	Heroism	150	96	RHTX9-BS	0012330	ETX9-BS	YTX9-BS
	Herself	125	-	RHTX7A-BS	0012350	ETX7A-BS	YTX7A-BS
	Hipster 150	150	-	RHTX7A-BS	0012350	ETX7A-BS	YTX7A-BS
Jockey 125	125	99	RHTX7L-BS	0012430	ETX7L-BS	YTX7L-BS	
Jockey 125	125	-	RHTX7A-BS	0012350	ETX7A-BS	YTX7A-BS	
Jockey 125 Fi	125	-	RHTX9-BS	0012330	ETX9-BS	YTX9-BS	
JR 100	100	-	RHTX7A-BS	0012350	ETX7A-BS	YTX7A-BS	

BATTERIE MOTO - ATV, UTV - MARINE

MARCA MAKE	MODELLO MODEL	CC CC	ANNO YEAR	BATTERIA RHIAG RHIAG BATTERY	BATTERIA MPT MOTORPARTS BATTERY	BATTERIA EXIDE EXIDE BATTERY	BATTERIA YUASA YUASA BATTERY
KYMCO	JR 100 Fi	100	-	RHTX7A-BS	0012350	ETX7A-BS	YTX7A-BS
	K-XCT	125	12-	RHTX9-BS	0012330	ETX9-BS	YTX9-BS
	K-XCT	300	12-	RHT12B-BS	0012550	ET12B-BS	YT12B-BS
	K12	50	96-97	RHTX4L-BS	0012310	ETX4L-BS	YTX4L-BS
	KB	50	97	RHTX4L-BS	0012310	ETX4L-BS	YTX4L-BS
	KB	100	97	RHTX5L-BS	0012380	ETX5L-BS	YTX5L-BS
	Kiwi 100	100	-	RHTX7A-BS	0012350	ETX7A-BS	YTX7A-BS
	Kiwi 50	50	-	RHTX5L-BS	0012380	ETX5L-BS	YTX5L-BS
	KTR 150	150	-	RHT9B-BS	0012530	ET9B-BS	YT9B-BS
	Many 100 Fi	100	11-	RHTX7A-BS	0012350	ETX7A-BS	YTX7A-BS
	Many 110	110	11-	RHTX7A-BS	0012350	ETX7A-BS	YTX7A-BS
	Many 50 Fi	50	11-	RHTX7A-BS	0012350	ETX7A-BS	YTX7A-BS
	Meteorit	125	-	RHTX7L-BS	0012430	ETX7L-BS	YTX7L-BS
	Movie	150	06-07	RHTX9-BS	0012330	ETX9-BS	YTX9-BS
	Movie 125	125	99	RHTX9-BS	0012330	ETX9-BS	YTX9-BS
	My road	700	-	RHTX14-BS	0012390	ETX14-BS	YTX14-BS
	Nikita 300 Fi	300	11-	RHT12A-BS	0012470	ET12A-BS	YT12A-BS
	People	200	05	RHTX7A-BS	0012350	ETX7A-BS	YTX7A-BS
	People	250	04-10	RHTX12-BS	0012320	ETX12-BS	YTX12-BS
	People 125	125	00-10	RHTX7A-BS	0012350	ETX7A-BS	YTX7A-BS
	People 4T	50	06-08	RHTX7A-BS	0012350	ETX7A-BS	YTX7A-BS
	People 9, People	50	00-10	RHTZ7S-BS/RHTX5L-BS	0012380	ETX5L-BS	YTX5L-BS
	People GT	125	-	RHT12A-BS	0012470	ET12A-BS	YT12A-BS
	People GT	300	10-	RHT12A-BS	0012470	ET12A-BS	YT12A-BS
	People GTI	125	10-	RHT12A-BS	0012470	ET12A-BS	YT12A-BS
	People GTI	200	10-	RHT12A-BS	0012470	ET12A-BS	YT12A-BS
	People S	125	-	RHTX7A-BS	0012350	ETX7A-BS	YTX7A-BS
	People S	250	-	RHTX12-BS	0012320	ETX12-BS	YTX12-BS
	People S (2T)	50	-	RHTX4L-BS	0012310	ETX4L-BS	YTX4L-BS
	People S 200I	200	07	RHTZ10S-BS	0012540		YTZ10S-BS
	People S, Super 8	150	09-10	RHTX7A-BS	0012350	ETX7A-BS	YTX7A-BS
	People, S	200	11-	RHTX7A-BS	0012350	ETX7A-BS	YTX7A-BS
	Quannon	125	-	RHT7B-BS	0012520	ET7B-BS	YT7B-BS
	Quannon	150	-	RHT7B-BS	0012520	ET7B-BS	YT7B-BS
	Quannon Naked	125	10-	RHT7B-BS	0012520	ET7B-BS	YT7B-BS
	Racer, Looping, People	50	99	RHTX5L-BS	0012380	ETX5L-BS	YTX5L-BS
	Racing	180	-	RHTX9-BS	0012330	ETX9-BS	YTX9-BS
	Racing 125	125	-	RHTX9-BS	0012330	ETX9-BS	YTX9-BS
	Racing 150	150	-	RHTX9-BS	0012330	ETX9-BS	YTX9-BS
	Racing 150 Fi	150	-	RHTX9-BS	0012330	ETX9-BS	YTX9-BS
	Scout	50	97	RHTX4L-BS	0012310	ETX4L-BS	YTX4L-BS
	Sniper/Sniper DD	50	00-	RHTX4L-BS	0012310	ETX4L-BS	YTX4L-BS
	So Easy	100	-	RHTX5L-BS	0012380	ETX5L-BS	YTX5L-BS
	So Easy Fi	100	-	RHTX7A-BS	0012350	ETX7A-BS	YTX7A-BS
	Sonner 100	100	-	RHTX7A-BS	0012350	ETX7A-BS	YTX7A-BS
	Spacer	50	99	RHTX5L-BS	0012380	ETX5L-BS	YTX5L-BS
	Spacer	125	99	RHTX9-BS	0012330	ETX9-BS	YTX9-BS
	Spacer	150	99	RHTX9-BS	0012330	ETX9-BS	YTX9-BS
	Super 8	50	07	RHTX7A-BS	0012350	ETX7A-BS	YTX7A-BS
	Super 9	50	99-10	RHTX5L-BS/RHTZ7S-BS	0012380	ETX5L-BS	YTX5L-BS

MARCA	MODELLO	CC	ANNO	BATTERIA RHIAG	BATTERIA MPT	BATTERIA EXIDE	BATTERIA YUASA
MAKE	MODEL	CC	YEAR	RHIAG BATTERY	MOTORPARTS BATTERY	EXIDE BATTERY	YUASA BATTERY
KYMCO	Super 9 (2T)	50	-	RHTX4L-BS	0012310	ETX4L-BS	YTX4L-BS
	Super 9 (4T)	50	-	RHTX5L-BS	0012380	ETX5L-BS	YTX5L-BS
	Super-9	250	00-	RHTX12-BS	0012320	ETX12-BS	YTX12-BS
	Top Boy	50	97	RHTX5L-BS	0012380	ETX5L-BS	YTX5L-BS
	Top Boy	100	97	RHTX5L-BS	0012380	ETX5L-BS	YTX5L-BS
	V1 125 Fi	125	11-	RHTX7A-BS	0012350	ETX7A-BS	YTX7A-BS
	V1 150 Fi	150	11-	RHTX9-BS	0012330	ETX9-BS	YTX9-BS
	Venox	250	-	RHTX9-BS	0012330	ETX9-BS	YTX9-BS
	Vitality 2T	50	04	RHTX4L-BS	0012310	ETX4L-BS	YTX4L-BS
	Vitality 4T	50	04	RHTX5L-BS	0012380	ETX5L-BS	YTX5L-BS
	Vivio	125	-	RHTX9-BS	0012330	ETX9-BS	YTX9-BS
	Vivio	150	-	RHTX9-BS	0012330	ETX9-BS	YTX9-BS
	VJR	110	11-	RHTX7A-BS	0012350	ETX7A-BS	YTX7A-BS
	VJR 100 Fi	100	11-	RHTX7A-BS	0012350	ETX7A-BS	YTX7A-BS
	VJR 50 Fi	50	11-	RHTX7A-BS	0012350	ETX7A-BS	YTX7A-BS
	VP 125	125	-	RHTX7A-BS	0012350	ETX7A-BS	YTX7A-BS
	VP125 Fi	125	11-	RHTZ10S-BS	0012540		YTX10S-BS
	X Citing	250	05-10	RHTX12-BS	0012320	ETX12-BS	YTX12-BS
	X Citing	300	08	RHTX12-BS	0012320	ETX12-BS	YTX12-BS
	X Citing	500	05-08	RHTX14-BS	0012390	ETX14-BS	YTX14-BS
	X MODE	100	11-	RHTX7A-BS	0012350	ETX7A-BS	YTX7A-BS
	Xciting	400	09	RHTX12-BS	0012320	ETX12-BS	YTX12-BS
	Xciting 500i	500	-	RHTX14-BS	0012390	ETX14-BS	YTX14-BS
	YN 50	50	-	RHTX4L-BS	0012310	ETX4L-BS	YTX4L-BS
	Yuo	250	03	RHTX12-BS	0012320	ETX12-BS	YTX12-BS
	Yup	50	02-03	RHTX4L-BS	0012310	ETX4L-BS	YTX4L-BS
	Zing	125	99	RHTX7L-BS	0012430	ETX7L-BS	YTX7L-BS
	Zing	150	99	RHTX7L-BS	0012430	ETX7L-BS	YTX7L-BS
	ZX Fever	50	95-97	RHTX4L-BS	0012310	ETX4L-BS	YTX4L-BS
	LAVERDA	1200	1200	-	RH60-N24AL-B		
1000RGS		1000	-	RH60-N30L-AHD	0012730		53030
Phoenix		125	-	RHTX9-BS	0012330	ETX9-BS	YTX9-BS
Phoenix		150	-	RHTX9-BS	0012330	ETX9-BS	YTX9-BS
MALAGUTI	Phoenix	200	-	RHTX9-BS	0012330	ETX9-BS	YTX9-BS
	Centro	125	08	RHTX9-BS	0012330	ETX9-BS	YTX9-BS
	Centro	160	08	RHTX9-BS	0012330	ETX9-BS	YTX9-BS
	Centro, SL	50	94-	RHB4L-B	0012180	EB4L-B	YB4L-B
	Centro, SL/ SL Kar	50	-	RHB5L-B	0012240	EB5L-B	YB5L-B
	CIAK	50	99	RHB4L-B	0012180	EB4L-B	YB4L-B
	Ciak	50	99-	RHB5L-B	0012240	EB5L-B	YB5L-B
	CIAK	100	99	RHB5L-B	0012240	EB5L-B	YB5L-B
	Ciak	125	-	RHB9-B		EB9-B	YB9-B
	Ciak	150	-	RHB9-B		EB9-B	YB9-B
	Ciak Master	50	04-06	RHB5L-B	0012240	EB5L-B	YB5L-B
	Ciak Master	125	04-08	RHTX9-BS	0012330	ETX9-BS	YTX9-BS
	Ciak Master	150	-	RHTX9-BS	0012330	ETX9-BS	YTX9-BS
	Ciak Master	180	06	RHTX9-BS	0012330	ETX9-BS	YTX9-BS
	CNK Drakon	50	-	RHB5L-B	0012240	EB5L-B	YB5L-B
	Colors	50	-	RHB4L-B	0012180	EB4L-B	YB4L-B
	CR1	50	96-	RHB4L-B	0012180	EB4L-B	YB4L-B
Crosser	50	-	RHB4L-B	0012180	EB4L-B	YB4L-B	

BATTERIE MOTO
ATV/UTV/MARINE

BATTERIE MOTO - ATV, UTV - MARINE

MARCA MAKE	MODELLO MODEL	CC CC	ANNO YEAR	BATTERIA RHIAG RHIAG BATTERY	BATTERIA MPT MOTORPARTS BATTERY	BATTERIA EXIDE EXIDE BATTERY	BATTERIA YUASA YUASA BATTERY	
MALAGUTI	Dune ES	50	89	RHB4L-B	0012180	EB4L-B	YB4L-B	
	Evolution	50	-	RHB4L-B	0012180	EB4L-B	YB4L-B	
	F.10	50	-	RHB4L-B	0012180	EB4L-B	YB4L-B	
	F10, F12/F12LC	50	-	RHB4L-B	0012180	EB4L-B	YB4L-B	
	F12	100	-	RHTX5L-BS	0012380	ETX5L-BS	YTX5L-BS	
	F12LC Twin Disk	50	-	RHB4L-B	0012180	EB4L-B	YB4L-B	
	F12R Phantom	50	07-08	RHB5L-B	0012240	EB5L-B	YB5L-B	
	F15 Twin Disk/Digit	50	-	RHB4L-B	0012180	EB4L-B	YB4L-B	
	F15/F15 Twin Disk	50	-	RHB4L-B	0012180	EB4L-B	YB4L-B	
	F18	125	-	RHB9-B		EB9-B	YB9-B	
	F18	150	-	RHB9-B		EB9-B	YB9-B	
	Fire Fox F15/LC	50	-	RHB5L-B	0012240	EB5L-B	YB5L-B	
	Fitty Top	50	91	RHB4L-B	0012180	EB4L-B	YB4L-B	
	Grosser EL	50	98	RHB4L-B	0012180	EB4L-B	YB4L-B	
	Madison	125	00-	RHB9-B		EB9-B	YB9-B	
	Madison	150	-	RHB9-B		EB9-B	YB9-B	
	Madison	180	02-03	RHB9-B		EB9-B	YB9-B	
	Madison	180	-	RHB9-B		EB9-B	YB9-B	
	Madison	250	04	RHB12AL-A	0012340	EB12AL-A	YB12AL-A	
	Madison	250	99-01	RHB9-B		EB9-B	YB9-B	
	Madison	400	-	RHB12AL-A	0012340	EB12AL-A	YB12AL-A	
	Madison 3	250	06	RHTX12-BS	0012320	ETX12-BS	YTX12-BS	
	Mistral	50	-	RHB4L-B	0012180	EB4L-B	YB4L-B	
	New Dribbling	50	-	RHB4L-B	0012180	EB4L-B	YB4L-B	
	Password	250	07-08	RHTX12-BS	0012320	ETX12-BS	YTX12-BS	
	Phantom F.12	50	-	RHB4L-B	0012180	EB4L-B	YB4L-B	
	Phantom F.12	100	99	RHTX5L-BS	0012380	ETX5L-BS	YTX5L-BS	
	Phantom Max	125	03	RHB9-B		EB9-B	YB9-B	
	Phantom Max	180	03	RHB9-B		EB9-B	YB9-B	
	Phantom Max	250	04	RHTX12-BS	0012320	ETX12-BS	YTX12-BS	
	RST	50	-	RHB4L-B	0012180	EB4L-B	YB4L-B	
	RST	90	-	RHB4L-B	0012180	EB4L-B	YB4L-B	
	Spider Max	500	04-08	RHTX14-BS	0012390	ETX14-BS	YTX14-BS	
	Top	50	-	RHB4L-B	0012180	EB4L-B	YB4L-B	
	X3M	125	08	RHTX7L-BS	0012430	ETX7L-BS	YTX7L-BS	
	XMS	50	03-08	RHB4L-B	0012180	EB4L-B	YB4L-B	
	XSM Power-Up	50	07-08	RHB5L-B	0012240	EB5L-B	YB5L-B	
	XTM	50	03-08	RHB4L-B	0012180	EB4L-B	YB4L-B	
	Yesterday, EURO	50	-	RHB4L-B	0012180	EB4L-B	YB4L-B	
	MBK	Active	50	-	RHB4L-B	0012180	EB4L-B	YB4L-B
		Booster	50	93-96	RHB4L-B	0012180	EB4L-B	YB4L-B
		Booster	100	01	RHB4L-B	0012180	EB4L-B	YB4L-B
Booster		100	99-00	RHTX5L-BS	0012380	ETX5L-BS	YTX5L-BS	
Booster NG		50	96-97	RHTX4L-BS	0012310	ETX4L-BS	YTX4L-BS	
Booster Road		50	95	RHTX4L-BS	0012310	ETX4L-BS	YTX4L-BS	
Booster Rocket		50	96-97	RHTX4L-BS	0012310	ETX4L-BS	YTX4L-BS	
Booster Spirit		50	-99	RHTX4L-BS	0012310	ETX4L-BS	YTX4L-BS	
Booster Track		50	-99	RHTX4L-BS	0012310	ETX4L-BS	YTX4L-BS	
CR Z		50	-	RHB4L-B	0012180	EB4L-B	YB4L-B	
CT S		50	-	RHB4L-B	0012180	EB4L-B	YB4L-B	
Equalis		50	-99	RHB4L-B	0012180	EB4L-B	YB4L-B	

MARCA MAKE	MODELLO MODEL	CC CC	ANNO YEAR	BATTERIA RHIAG RHIAG BATTERY	BATTERIA MPT MOTORPARTS BATTERY	BATTERIA EXIDE EXIDE BATTERY	BATTERIA YUASA YUASA BATTERY	
MBK	Evolis	50	93-97	RHB4L-B	0012180	EB4L-B	YB4L-B	
	Evolis	80	95-98	RHB4L-B	0012180	EB4L-B	YB4L-B	
	EW	50	-	RHB4L-B	0012180	EB4L-B	YB4L-B	
	Fizz	50	95-96	RHB4L-B	0012180	EB4L-B	YB4L-B	
	Flame	125	95-97	RHTX7A-BS	0012350	ETX7A-BS	YTX7A-BS	
	Flame-R	125	-98	RHTX7A-BS	0012350	ETX7A-BS	YTX7A-BS	
	Flipper	50	01	RHB4L-B	0012180	EB4L-B	YB4L-B	
	Forte	50	96-97	RHB4L-B	0012180	EB4L-B	YB4L-B	
	Kilibre	250	03	RHTX9-BS	0012330	ETX9-BS	YTX9-BS	
	Kilibre	300	03	RHTX9-BS	0012330	ETX9-BS	YTX9-BS	
	Match G	50	-	RHB4L-B	0012180	EB4L-B	YB4L-B	
	Nitro	50	-99	RHB4L-B	0012180	EB4L-B	YB4L-B	
	Nitro	100	01	RHB4L-B	0012180	EB4L-B	YB4L-B	
	Nitro	100	99-00	RHTX5L-BS	0012380	ETX5L-BS	YTX5L-BS	
	Ovetto	50	-99	RHB4L-B	0012180	EB4L-B	YB4L-B	
	Ovetto	100	01	RHB4L-B	0012180	EB4L-B	YB4L-B	
	Ovetto	100	99-00	RHTX5L-BS	0012380	ETX5L-BS	YTX5L-BS	
	Skyliner	250	99-00	RHTZ7S-BS	0012500		YTZ7S-BS	
	Sorriso	50	-	RHB4L-B	0012180	EB4L-B	YB4L-B	
	Stunt	50	01	RHB4L-B	0012180	EB4L-B	YB4L-B	
	Target	50	-	RHB4L-B	0012180	EB4L-B	YB4L-B	
	Vertex	150	-	RHTX7A-BS	0012350	ETX7A-BS	YTX7A-BS	
	X-Limit	50	03	RHB4L-B	0012180	EB4L-B	YB4L-B	
	X-Limit DT50	50	97	RHB4L-B	0012180	EB4L-B	YB4L-B	
	X-Over	125	10-	RHT7B-BS	0012520	ET7B-BS	YT7B-BS	
	XC Flame/Flame R	125	-	RHTX7A-BS	0012350	ETX7A-BS	YTX7A-BS	
	XT660R	660	-	RHT9B-BS	0012530	ET9B-BS	YT9B-BS	
	MOTO GUZZI	1000 NT	1000	-	RH60-N30L-AHD	0012730		53030
		1000S	1000	94-98	RH60-N30L-AHD	0012730		53030
		Bellagio	936	10-	RHTX20L-BS	0012640		YTX20L-BS
Bellagio		940	07-10	RHTX20L-BS	0012640		YTX20L-BS	
Breva, Griso		1100	05-06	RHTX20L-BS	0012640		YTX20L-BS	
California		1000	-	RH60-N24AL-B				
California		1100	94-05	RH60-N30L-AHD	0012730		53030	
California		1100	94-05	RH60-N30L-AHD	0012730		53030	
California Classic, Vintage		1064	10-	RHTX20L-BS	0012640		YTX20L-BS	
California EV, Stone		1100	99-04	RH60-N30L-AHD	0012730		53030	
California III		1000	88-93	RH60-N30L-AHD	0012730		53030	
California-Alluminium-Titanium		1000	03-04	RH60-N30L-AHD	0012730		53030	
Convert		1000	-	RH60-N30L-AHD	0012730		53030	
Custom		125	-	RHB9-B		EB9-B	YB9-B	
Daytona		1000	-	RH60-N30L-AHD	0012730		53030	
Falcone u .t.		500	-	RHTX20L-BS	0012640		YTX20L-BS	
G5/Convert		1000	-	RH60-N24AL-B				
GT		1000	-	RH60-N24AL-B				
Le Mans		850	-	RH60-N30L-AHD	0012730		53030	
Le Mans		1000	-	RH60-N30L-AHD	0012730		53030	
Le Mans III		1000	85-93	RH60-N30L-AHD	0012730		53030	
MGS-01CORSA		1256	-	RHTX20L-BS	0012640		YTX20L-BS	
Mille		1000	-	RH60-N30L-AHD	0012730		53030	
Nevada N.T		650	94-98	RH60-N30L-AHD	0012730		53030	

BATTERIE MOTO - ATV, UTV - MARINE

MARCA MAKE	MODELLO MODEL	CC CC	ANNO YEAR	BATTERIA RHIAG RHIAG BATTERY	BATTERIA MPT MOTORPARTS BATTERY	BATTERIA EXIDE EXIDE BATTERY	BATTERIA YUASA YUASA BATTERY	
MOTO GUZZI	NTX	650	-	RHTX20L-BS	0012640		YTX20L-BS	
	NTX	750	-	RHTX20L-BS	0012640		YTX20L-BS	
	Quota	1000	-	RH60-N30L-AHD	0012730		53030	
	Quota 1100ES	1100	00-01	RH60-N30L-AHD	0012730		53030	
	SP	1000	-	RHTX20L-BS	0012640		YTX20L-BS	
	SP II/III	1000	-	RH60-N24AL-B				
	SP/California/III	1000	-	RH60-N30L-AHD	0012730		53030	
	Sport Carburatore	1100	94-96	RHTX20L-BS	0012640		YTX20L-BS	
	Sport Corsa	1100	98-99	RH60-N24AL-B				
	Stone, EV	1100	94-05	RH60-N30L-AHD	0012730		53030	
	Strada	750	93-96	RH60-N30L-AHD	0012730		53030	
	Strada	1000	93-96	RH60-N30L-AHD	0012730		53030	
	T3, T4, T5	850	-	RH60-N30L-AHD	0012730		53030	
	T3, T4, T5 III	850	81-88	RH60-N30L-AHD	0012730		53030	
	Targa	750	90-93	RH60-N30L-AHD	0012730		53030	
	V10 Centauro	1000	-	RHT12B-BS	0012550	ET12B-BS	YT12B-BS	
	V11 Ballabio	1100	-	RHTX20L-BS	0012640		YTX20L-BS	
	V11 Bassa	1100	99-00	RH60-N30L-AHD	0012730		53030	
	V11 EV	1100	98-99	RH60-N30L-AHD	0012730		53030	
	V11 Le Mans	1100	-	RH60-N30L-AHD	0012730		53030	
	V11 Sport	1100	99-	RH60-N24AL-B				
	V35	350	80-87	RH60-N30L-AHD	0012730		53030	
	V35 carabinieri	350	92-01	RH60-N30L-AHD	0012730		53030	
	V35 II	350	81-86	RH60-N30L-AHD	0012730		53030	
	V35 Imola/V35 Monza	350	-	RH60-N30L-AHD	0012730		53030	
	V35/V35 GT/V35 C	350	-	RH60-N30L-AHD	0012730		53030	
	V50 Imola/V50 Monza	500	-	RH60-N30L-AHD	0012730		53030	
	V50/V50C/	500	-	RH60-N30L-AHD	0012730		53030	
	V65	650	-	RH60-N30L-AHD	0012730		53030	
	V65 Florida	650	85-92	RHTX20L-BS	0012640		YTX20L-BS	
	V65 GT	650	87-94	RH60-N30L-AHD	0012730		53030	
	V65 Lario	650	84-87	RH60-N30L-AHD	0012730		53030	
	V65 Sport	650	82-87	RH60-N30L-AHD	0012730		53030	
	V7	750	-	RH60-N30L-AHD	0012730		53030	
	V7	750	12-	RHTX14-BS	0012390	ETX14-BS	YTX14-BS	
	V75	750	-	RHTX20L-BS	0012640		YTX20L-BS	
	VII Bassa	1100	99-00	RH60-N30L-AHD	0012730		53030	
	VII EV	1100	98-99	RH60-N30L-AHD	0012730		53030	
	MOTOBECANE	Active	80	-	RHB4L-B	0012180	EB4L-B	YB4L-B
		Booster, Hot Champ	50	-	RHB4L-B	0012180	EB4L-B	YB4L-B
Moped, Target		50	-	RHB4L-B	0012180	EB4L-B	YB4L-B	
MOTRON	Compact Racing RZ1	50	-	RHB4L-B	0012180	EB4L-B	YB4L-B	
	Invader	50	-	RHB4L-B	0012180	EB4L-B	YB4L-B	
	Spike	50	-	RHB4L-B	0012180	EB4L-B	YB4L-B	
	Sting	50	-	RHB4L-B	0012180	EB4L-B	YB4L-B	
	Syncro	50	-	RHB4L-B	0012180	EB4L-B	YB4L-B	
	Thunder	50	-	RHB4L-B	0012180	EB4L-B	YB4L-B	
	XLE	50	-	RHB4L-B	0012180	EB4L-B	YB4L-B	
	MUZ	Roadster	125	-	RHB5L-B	0012240	EB5L-B	YB5L-B
Saxon Sportstar		125	-	RHB5L-B	0012240	EB5L-B	YB5L-B	
Saxton Fun, Tour		251	-	RHB5L-B	0012240	EB5L-B	YB5L-B	

MARCA	MODELLO	CC	ANNO	BATTERIA RHIAG	BATTERIA MPT	BATTERIA EXIDE	BATTERIA YUASA	
MAKE	MODEL	CC	YEAR	RHIAG BATTERY	MOTORPARTS BATTERY	EXIDE BATTERY	YUASA BATTERY	
MUZ MV AGUSTA	Saxton Fun, Tour	301	-	RHB5L-B	0012240	EB5L-B	YB5L-B	
	Aviamento, GT	750	-	RH60-N30L-AHD	0012730		53030	
	Brutale	800	12-	RHTZ10S-BS	0012540		YTZ10S-BS	
	Brutale	910	05-08	RHTZ10S-BS	0012540		YTZ10S-BS	
	Brutale 675	675	11-	RHTZ10S-BS	0012540		YTZ10S-BS	
	Brutale 920 MY2012	920	12	RHTZ10S-BS	0012540		YTZ10S-BS	
	Brutale 990 R	990	11-	RHTZ10S-BS	0012540		YTZ10S-BS	
	Brutale R 1090	1090	11-	RHTZ10S-BS	0012540		YTZ10S-BS	
	Brutale RR 1090	1090	11-	RHTZ10S-BS	0012540		YTZ10S-BS	
	F3 675	675	11-	RHTZ10S-BS	0012540		YTZ10S-BS	
	F4 R	1000	12	RHTZ10S-BS	0012540		YTZ10S-BS	
	F4 RR	1000	12	RHTZ10S-BS	0012540		YTZ10S-BS	
	F4 Series	1000	05-10	RHTZ10S-BS	0012540		YTZ10S-BS	
	F4, Brutale	750	00-06	RHTZ10S-BS	0012540		YTZ10S-BS	
	F4, Brutale(989,1078)	1078	05-10	RHTZ10S-BS	0012540		YTZ10S-BS	
MZ	F4,SERIE Oro	750	01-	RHTX9-BS	0012330	ETX9-BS	YTX9-BS	
	Roadstar	125	93-94	RHB5L-B	0012240	EB5L-B	YB5L-B	
	Saxon Fun	301	93-94	RHB5L-B	0012240	EB5L-B	YB5L-B	
	Saxon Fun, Tour	251	93-94	RHB5L-B	0012240	EB5L-B	YB5L-B	
	Saxon Sport Star	125	93-97	RHB5L-B	0012240	EB5L-B	YB5L-B	
	Saxon Tour	301	93-94	RHB5L-B	0012240	EB5L-B	YB5L-B	
	PEUGEOT	Buxy	50	95-97	RHB4L-B	0012180	EB4L-B	YB4L-B
		Buxy RS	50	96-97	RHB4L-B	0012180	EB4L-B	YB4L-B
		Ciclomotore (Electric-Starter)	105	01-	RHB4L-B	0012180	EB4L-B	YB4L-B
		Ciclomotore(E-Starter)	125	01-	RHB4L-B	0012180	EB4L-B	YB4L-B
CityStar		125	11-	RHB12AL-A	0012340	EB12AL-A	YB12AL-A	
Elyseo		50	98	RHB4L-B	0012180	EB4L-B	YB4L-B	
Elyseo		100	99-01	RHTX5L-BS	0012380	ETX5L-BS	YTX5L-BS	
Elyseo		125	98	RHB12AL-A	0012340	EB12AL-A	YB12AL-A	
Elyseo		150	98	RHB12AL-A	0012340	EB12AL-A	YB12AL-A	
FOX LA		25	95-97	RHB4L-B	0012180	EB4L-B	YB4L-B	
FOX Lux		50	95-97	RHB4L-B	0012180	EB4L-B	YB4L-B	
GEOPOLIS		125	05	RHB12AL-A	0012340	EB12AL-A	YB12AL-A	
GEOPOLIS		250	05	RHB12AL-A	0012340	EB12AL-A	YB12AL-A	
Jet Force		50	03	RHB4L-B	0012180	EB4L-B	YB4L-B	
Liberty		50	-	RHB4L-B	0012180	EB4L-B	YB4L-B	
Looxor	50	01-	RHB4L-B	0012180	EB4L-B	YB4L-B		
Looxor	100	01-	RHTX5L-BS	0012380	ETX5L-BS	YTX5L-BS		
Looxor	125	02-03	RHTX9-BS	0012330	ETX9-BS	YTX9-BS		
Looxor	150	02-03	RHTX9-BS	0012330	ETX9-BS	YTX9-BS		
Ludix	50	04-06	RHB4L-B	0012180	EB4L-B	YB4L-B		
Metal X	50	02	RHB4L-B	0012180	EB4L-B	YB4L-B		
Rapido/Rapido 3	50	01-	RHB4L-B	0012180	EB4L-B	YB4L-B		
SATELIS	250	06	RHB12AL-A	0012340	EB12AL-A	YB12AL-A		
SATELIS	400	07	RHTX12-BS	0012320	ETX12-BS	YTX12-BS		
SATELIS	500	07	RHTX12-BS	0012320	ETX12-BS	YTX12-BS		
SC80LI (Metropolis)	80	-	RHB4L-B	0012180	EB4L-B	YB4L-B		
SCLI Metropolis	50	01-	RHB4L-B	0012180	EB4L-B	YB4L-B		
Speedake	50	01-	RHB4L-B	0012180	EB4L-B	YB4L-B		
Speedfight	50	97-99	RHB4L-B	0012180	EB4L-B	YB4L-B		

BATTERIE MOTO - ATV, UTV - MARINE

MARCA MAKE	MODELLO MODEL	CC CC	ANNO YEAR	BATTERIA RHIAG RHIAG BATTERY	BATTERIA MPT MOTORPARTS BATTERY	BATTERIA EXIDE EXIDE BATTERY	BATTERIA YUASA YUASA BATTERY
PEUGEOT	Speedfight	100	01-	RHTX5L-BS	0012380	ETX5L-BS	YTX5L-BS
	Speedfight 2	50	00-	RHB4L-B	0012180	EB4L-B	YB4L-B
	Speedfight 2	100	00-	RHTX5L-BS	0012380	ETX5L-BS	YTX5L-BS
	Speedfight/LC	50	97-99	RHB4L-B	0012180	EB4L-B	YB4L-B
	Speedfighter	100	98	RHTX5L-BS	0012380	ETX5L-BS	YTX5L-BS
	Squab	50	96-97	RHB4L-B	0012180	EB4L-B	YB4L-B
	ST	50	01-	RHB4L-B	0012180	EB4L-B	YB4L-B
	ST	250	01-	RHTX12-BS	0012320	ETX12-BS	YTX12-BS
	SV	100	-97	RHB5L-B	0012240	EB5L-B	YB5L-B
	SV	250	-	RHTX12-BS	0012320	ETX12-BS	YTX12-BS
	SV 80	80	93-96	RHB5L-B	0012240	EB5L-B	YB5L-B
	SV Blue Star	50	97	RHB4L-B	0012180	EB4L-B	YB4L-B
	SV Junior	50	93-96	RHB4L-B	0012180	EB4L-B	YB4L-B
	SV-125	125	93-97	RHB5L-B	0012240	EB5L-B	YB5L-B
	SV/SV Geo	50	93-97	RHTX5L-BS	0012380	ETX5L-BS	YTX5L-BS
	TKR	100	-	RHTX5L-BS	0012380	ETX5L-BS	YTX5L-BS
	Trekker	100	98	RHTX5L-BS	0012380	ETX5L-BS	YTX5L-BS
	Trekker	100	01-	RHTX5L-BS	0012380	ETX5L-BS	YTX5L-BS
	Trekker Road/Off Road	50	99	RHB4L-B	0012180	EB4L-B	YB4L-B
	TRK2 WRC	50	04-06	RHB4L-B	0012180	EB4L-B	YB4L-B
	Tweet 125	125	10-	RHTX7A-BS	0012350	ETX7A-BS	YTX7A-BS
	Tweet 50	50	10-	RHTX7A-BS	0012350	ETX7A-BS	YTX7A-BS
	Vivacity	50	99	RHB4L-B	0012180	EB4L-B	YB4L-B
	Vivacity	100	99	RHTX5L-BS	0012380	ETX5L-BS	YTX5L-BS
	Vivacity	100	01-	RHTX5L-BS	0012380	ETX5L-BS	YTX5L-BS
	X-Fight	50	-	RHB4L-B	0012180	EB4L-B	YB4L-B
	X-Fight	100	01-	RHB4L-B	0012180	EB4L-B	YB4L-B
	X-Fight	100	01-	RHTX5L-BS	0012380	ETX5L-BS	YTX5L-BS
	XPS	50	03-04	RHB4L-B	0012180	EB4L-B	YB4L-B
	XR6	50	03-04	RHB4L-B	0012180	EB4L-B	YB4L-B
	Xrace	50	03	RHB4L-B	0012180	EB4L-B	YB4L-B
	Zenith	50	95-96	RHB4L-B	0012180	EB4L-B	YB4L-B
	Zenith	100	01-	RHB4L-B	0012180	EB4L-B	YB4L-B
PGO	Big Max	25	-	RHB4L-B	0012180	EB4L-B	YB4L-B
	Big Max	50	95-96	RHB4L-B	0012180	EB4L-B	YB4L-B
	Big Max	90	97	RHB4L-B	0012180	EB4L-B	YB4L-B
	Big Max Sport	50	96-97	RHB4L-B	0012180	EB4L-B	YB4L-B
	Comet	25	95-97	RHB4L-B	0012180	EB4L-B	YB4L-B
	Comet	50	93-96	RHB4L-B	0012180	EB4L-B	YB4L-B
	Comet Junior	50	94-97	RHB4L-B	0012180	EB4L-B	YB4L-B
	Galaxy	25	97	RHB4L-B	0012180	EB4L-B	YB4L-B
	Galaxy	50	93-97	RHB4L-B	0012180	EB4L-B	YB4L-B
	Galaxy	80	93-96	RHB4L-B	0012180	EB4L-B	YB4L-B
	Galaxy	90	94-97	RHB4L-B	0012180	EB4L-B	YB4L-B
	Mega	25	97	RHB4L-B	0012180	EB4L-B	YB4L-B
	Mega	50	97	RHB4L-B	0012180	EB4L-B	YB4L-B
	Star	80	93-96	RHB4L-B	0012180	EB4L-B	YB4L-B
	Star- Star II	50	93-96	RHB4L-B	0012180	EB4L-B	YB4L-B
	Tornado	50	97	RHB4L-B	0012180	EB4L-B	YB4L-B
	Tornado	90	97	RHB4L-B	0012180	EB4L-B	YB4L-B
	Tornado	125	-	RHB4L-B	0012180	EB4L-B	YB4L-B

MARCA	MODELLO	CC	ANNO	BATTERIA RHIAG	BATTERIA MPT	BATTERIA EXIDE	BATTERIA YUASA
MAKE	MODEL	CC	YEAR	RHIAG BATTERY	MOTORPARTS BATTERY	EXIDE BATTERY	YUASA BATTERY
PIAGGIO	APE CAR, MP, MPR, P602		-	RH60-N30L-AHD	0012730		53030
	Beverly	125	00-03	RHB9-B		EB9-B	YB9-B
	Beverly	200	01-	RHT12B-BS	0012550	ET12B-BS	YT12B-BS
	Beverly	250	04	RHB10L-B-P	0012480	EB10L-B	YB10L-B
	Beverly	400	06-08	RHTX14-BS	0012390	ETX14-BS	YTX14-BS
	Beverly	500	02-06	RHTX14-BS	0012390	ETX14-BS	YTX14-BS
	Beverly 125 EUR	125	-	RHB9-B		EB9-B	YB9-B
	Beverly 125 GT, 4T	125	-	RHB9-B		EB9-B	YB9-B
	Beverly 125 UK	125	-	RHB9-B		EB9-B	YB9-B
	Beverly 200	200	07-	RHTX12-BS	0012320	ETX12-BS	YTX12-BS
	Beverly 400 ie (Euro 3)	400	-	RHTX14-BS	0012390	ETX14-BS	YTX14-BS
	Beverly 400 ie Tourer (Euro3)	400	-	RHTX14-BS	0012390	ETX14-BS	YTX14-BS
	Beverly 500 Cruiser (Euro 3)	502	-	RHTX14-BS	0012390	ETX14-BS	YTX14-BS
	Beverly Cruiser	250	07-10	RHTX14-BS	0012390	ETX14-BS	YTX14-BS
	Beverly Cruiser	500	07-08	RHTX14-BS	0012390	ETX14-BS	YTX14-BS
	Beverly Eu3	400	06-07	RHB10L-B-P	0012480	EB10L-B	YB10L-B
	Beverly Eu3	500	06-08	RHTX14-BS	0012390	ETX14-BS	YTX14-BS
	Beverly Eu3/Tourer	125	07-08	RHB10L-B-P	0012480	EB10L-B	YB10L-B
	Beverly Euro3 MIC	250	07	RHTX14-BS	0012390	ETX14-BS	YTX14-BS
	Beverly IE/RST/Sport	250	04-07	RHB10L-B-P	0012480	EB10L-B	YB10L-B
	Beverly RST	125	04-07	RHB9-B		EB9-B	YB9-B
	Beverly RST 4T 4V ie (Euro 3)	125	10-	RHTX12-BS	0012320	ETX12-BS	YTX12-BS
	Beverly RST 4T 4V ie (Euro 3)	300	10-	RHTX12-BS	0012320	ETX12-BS	YTX12-BS
	Beverly Tourer	250	08	RHTX14-BS	0012390	ETX14-BS	YTX14-BS
	BV500	500	08-10	RHTX14-BS	0012390	ETX14-BS	YTX14-BS
	Carnaby	125	07-08	RHB10L-B-P	0012480	EB10L-B	YB10L-B
	Carnaby	200	07-08	RHTX14-BS	0012390	ETX14-BS	YTX14-BS
	Carnaby	250	08	RHTX14-BS	0012390	ETX14-BS	YTX14-BS
	Carnaby 200 4T (Euro 3) (2007-08)	200	-	RHTX14-BS	0012390	ETX14-BS	YTX14-BS
	Cosa	200	-96	RHB9-B		EB9-B	YB9-B
	Cosa, CL,FL, X	125	-95	RHB9-B		EB9-B	YB9-B
	D-M-B-NRG 2T H2O POW	50	-	RHB9-B		EB9-B	YB9-B
	Diesis	50	-	RHB4L-B	0012180	EB4L-B	YB4L-B
	Diesis	100	07-	RHTX4L-BS	0012310	ETX4L-BS	YTX4L-BS
	DNA	50	-	RHTX4L-BS	0012310	ETX4L-BS	YTX4L-BS
	DNA 125	125	-	RHB9-B		EB9-B	YB9-B
	DNA 125 4T	125	-	RHB10L-B-P	0012480	EB10L-B	YB10L-B
	DNA 180	180	-	RHB9-B		EB9-B	YB9-B
	DNA 180 4T	180	-	RHB10L-B-P	0012480	EB10L-B	YB10L-B
	Easy Moving	50	-	RHB4L-B	0012180	EB4L-B	YB4L-B
	ET-2	50	97	RHB4L-B	0012180	EB4L-B	YB4L-B
	Executive	125	00-	RHB9-B		EB9-B	YB9-B
	Executive	150	-	RHB9-B		EB9-B	YB9-B
	Fly	50	09-10	RHB9-B		EB9-B	YB9-B
	Fly	50	12-	RHTX7L-BS	0012430	ETX7L-BS	YTX7L-BS
	Fly	125	05-08	RHB9-B		EB9-B	YB9-B
	Fly	150	05-10	RHB9-B		EB9-B	YB9-B
Fly 150 4T USA	150	-	RHB9-B		EB9-B	YB9-B	
Fly 4T	50	-	RHB9-B		EB9-B	YB9-B	
Fly 4T	125	12-	RHT12B-BS	0012550	ET12B-BS	YT12B-BS	
Free 100 4T	100	-	RHTX7L-BS	0012430	ETX7L-BS	YTX7L-BS	

BATTERIE MOTO - ATV, UTV - MARINE

MARCA MAKE	MODELLO MODEL	CC CC	ANNO YEAR	BATTERIA RHIAG RHIAG BATTERY	BATTERIA MPT MOTORPARTS BATTERY	BATTERIA EXIDE EXIDE BATTERY	BATTERIA YUASA YUASA BATTERY
PIAGGIO	Free 50 Poste	50	-	RHTX4L-BS	0012310	ETX4L-BS	YTX4L-BS
	Free Delivery	50	01	RHTX4L-BS	0012310	ETX4L-BS	YTX4L-BS
	Free PTT	50	-	RHTX4L-BS	0012310	ETX4L-BS	YTX4L-BS
	Free, FD	50	94-99	RHB4L-B	0012180	EB4L-B	YB4L-B
	Free, FL	25	-	RHB4L-B	0012180	EB4L-B	YB4L-B
	Free, FL	50	94-99	RHB4L-B	0012180	EB4L-B	YB4L-B
	Free, FL, Zip	25	-	RHB4L-B	0012180	EB4L-B	YB4L-B
	Free4T	50	05-08	RHB9-B		EB9-B	YB9-B
	GPR 50	50	-	RHTX4L-BS	0012310	ETX4L-BS	YTX4L-BS
	Granturismo	125	-	RHTX12-BS	0012320	ETX12-BS	YTX12-BS
	Granturismo	200	-	RHB10L-B-P	0012480	EB10L-B	YB10L-B
	GTS300	300	10-	RHTX14-BS	0012390	ETX14-BS	YTX14-BS
	GTV250	250	-10	RHTX14-BS	0012390	ETX14-BS	YTX14-BS
	Hexagon	150	95-97	RHB9-B		EB9-B	YB9-B
	Hexagon	250	98	RHB9-B		EB9-B	YB9-B
	Hexagon	250	99	RHB10L-B-P	0012480	EB10L-B	YB10L-B
	Hexagon	250	98-00	RHB10L-B-P	0012480	EB10L-B	YB10L-B
	Hexagon 4T	180	-	RHB10L-B-P	0012480	EB10L-B	YB10L-B
	Hexagon GT	250	00-	RHTX12-BS	0012320	ETX12-BS	YTX12-BS
	Hexagon GTX	125	-	RHB10L-B-P	0012480	EB10L-B	YB10L-B
	Hexagon LX4	125	00-	RHTX12-BS	0012320	ETX12-BS	YTX12-BS
	Hexagon LXT	180	-99	RHB9-B		EB9-B	YB9-B
	Hexagon LXT	180	00-	RHTX12-BS	0012320	ETX12-BS	YTX12-BS
	Hexagon, Hexagon LX, RST	125	-99	RHB9-B		EB9-B	YB9-B
	ICE 50	50	-	RHTX4L-BS	0012310	ETX4L-BS	YTX4L-BS
	IMPELETR.V. 125 ET4	125	-	RHB9-B		EB9-B	YB9-B
	Liberty	50	-99	RHB4L-B	0012180	EB4L-B	YB4L-B
	Liberty	50	07-08	RHB9-B		EB9-B	YB9-B
	Liberty	125	12	RHTX12-BS	0012320	ETX12-BS	YTX12-BS
	Liberty	125	12	RHTX12-BS	0012320	ETX12-BS	YTX12-BS
	Liberty	125	99	RHB9-B		EB9-B	YB9-B
	Liberty	200	06	RHTX12-BS	0012320	ETX12-BS	YTX12-BS
	Liberty	200	03-04	RHB10L-B-P	0012480	EB10L-B	YB10L-B
	Liberty 150 4T (Euro 3)	150	-	RHTX12-BS	0012320	ETX12-BS	YTX12-BS
	Liberty 150 4T Sport (Euro 3)	150	-	RHTX12-BS	0012320	ETX12-BS	YTX12-BS
	Liberty 200 4T	200	-	RHTX12-BS/RHB10L-B-P	0012320/0012480	ETX12-BS/EB10L-B	YTX12-BS/YB10L-B
	Liberty 2T Sport	50	-	RHB9-B		EB9-B	YB9-B
	Liberty 2T, 2T RST	50	-	RHTX4L-BS	0012310	ETX4L-BS	YTX4L-BS
	Liberty 3V	125	14-	RHTX7L-BS	0012430	ETX7L-BS	YTX7L-BS
	Liberty 3V	150	14-	RHTX7L-BS	0012430	ETX7L-BS	YTX7L-BS
	Liberty 4T	50	04-	RHB9-B		EB9-B	YB9-B
	Liberty 4T	150	-	RHB10L-B-P	0012480	EB10L-B	YB10L-B
	Liberty 4T sport	200	06-07	RHB10L-B-P	0012480	EB10L-B	YB10L-B
	Liberty 4T, Sport	125	08	RHTX12-BS	0012320	ETX12-BS	YTX12-BS
	Liberty 4T. 4T RST	50	-	RHB9-B		EB9-B	YB9-B
	Liberty 50 4T PTT (D)	50	-	RHB9-B		EB9-B	YB9-B
	Liberty 50 4T PTT Belgio	50	-	RHB9-B		EB9-B	YB9-B
Liberty 50 4T PTT Portogallo	50	-	RHB9-B		EB9-B	YB9-B	
Liberty 50 4T PTT RST Ital	50	-	RHB9-B		EB9-B	YB9-B	
Liberty 50 4T PTT Slovenia	50	-	RHB9-B		EB9-B	YB9-B	
Liberty 50 4T RST Europa	50	-	RHB9-B		EB9-B	YB9-B	

MARCA	MODELLO	CC	ANNO	BATTERIA RHIAG	BATTERIA MPT	BATTERIA EXIDE	BATTERIA YUASA
MAKE	MODEL	CC	YEAR	RHIAG BATTERY	MOTORPARTS BATTERY	EXIDE BATTERY	YUASA BATTERY
PIAGGIO	Liberty 50 4T RST PTT Fran	50	-	RHB9-B		EB9-B	YB9-B
	Liberty LE 150	150	00-	RHB9-B		EB9-B	YB9-B
	Liberty PTT	50	04-05	RHTX4L-BS	0012310	ETX4L-BS	YTX4L-BS
	Liberty PTT	50	-	RHTX4L-BS	0012310	ETX4L-BS	YTX4L-BS
	Liberty RST	200	04	RHB10L-B-P	0012480	EB10L-B	YB10L-B
	Liberty Sport 150cc	150	-	RHT12A-BS	0012470	ET12A-BS	YT12A-BS
	Liberty4T	200	08	RHTX12-BS	0012320	ETX12-BS	YTX12-BS
	LX150	150	10-	RHB9-B		EB9-B	YB9-B
	LX150	150	12-	RHTX12-BS	0012320	ETX12-BS	YTX12-BS
	LX50	50	10-	RHB9-B		EB9-B	YB9-B
	M. BASE LIBERTY 125 RST	125	-	RHB9-B		EB9-B	YB9-B
	M.B. VESPA 25 KM/H (B-NL) Vers. Spec.	50	08	RHB9-B		EB9-B	YB9-B
	M.B. VESPA 25 KM/H LX (B-NL-D-DK)	50	08	RHB9-B		EB9-B	YB9-B
	M.B. VESPA 50 LX E.3 SVIZZERA	50	08	RHB9-B		EB9-B	YB9-B
	M.B. VESPA 50 LXS BUDGET	50	07	RHB9-B		EB9-B	YB9-B
	M.B. VESPA 50/2T LX 30 Km/h DK	50	08	RHB9-B		EB9-B	YB9-B
	M.B. VESPA 50/2T LX EUROPA	50	08	RHB9-B		EB9-B	YB9-B
	M.B. VESPA 50/2T LX GERMANIA	50	08	RHB9-B		EB9-B	YB9-B
	Motore Go-Kart 200cc	200	-	RHTX7L-BS	0012430	ETX7L-BS	YTX7L-BS
	Mp3	125	07-08	RHTX14-BS	0012390	ETX14-BS	YTX14-BS
	Mp3	250	06-10	RHTX14-BS	0012390	ETX14-BS	YTX14-BS
	Mp3	500	08-10	RHTX14-BS	0012390	ETX14-BS	YTX14-BS
	Nexus 125	125	-	RHTX12-BS	0012320	ETX12-BS	YTX12-BS
	Nexus 300 ie (Euro3)	300	-	RHTX14-BS	0012390	ETX14-BS	YTX14-BS
	Nexus 500cc	500	-	RHTX14-BS	0012390	ETX14-BS	YTX14-BS
	Nexus ie	300	-	RHTX14-BS	0012390	ETX14-BS	YTX14-BS
	Nexus, Euro 3	250	-	RHTX14-BS	0012390	ETX14-BS	YTX14-BS
	Nexus, SP Euro 3	250	-	RHTX14-BS	0012390	ETX14-BS	YTX14-BS
	NRG	50	-	RHTX4L-BS	0012310	ETX4L-BS	YTX4L-BS
	NRG	50	94-96	RHB4L-B	0012180	EB4L-B	YB4L-B
	NRG Extreme	50	95-99	RHB4L-B	0012180	EB4L-B	YB4L-B
	NRG Extreme	50	99-00	RHTX4L-BS	0012310	ETX4L-BS	YTX4L-BS
	NRG MC2	50	96-98	RHB4L-B	0012180	EB4L-B	YB4L-B
	NRG MC3	50	01-04	RHB4L-B	0012180	EB4L-B	YB4L-B
	NRG Power DD/DT	50	05-07	RHB4L-B	0012180	EB4L-B	YB4L-B
	NRG Power DD/DT Serie Speciale	50	07-08	RHB9-B		EB9-B	YB9-B
	NRG Power Pure Jet	50	02-08	RHB9-B		EB9-B	YB9-B
	NRG PureJet	50	03-	RHB9-B		EB9-B	YB9-B
	NTT	50	-	RHB4L-B	0012180	EB4L-B	YB4L-B
	P200E (Electric-Start)	200	-	RHB9-B		EB9-B	YB9-B
	Puch P1-TRE	50	93-98	RHB4L-B	0012180	EB4L-B	YB4L-B
	PX125+80E-ARC	125	-	RHB9-B		EB9-B	YB9-B
	PX125T5	125	-	RHB9-B		EB9-B	YB9-B
	PX150E	150	-	RHB9-B		EB9-B	YB9-B
	PX150E-ARC	150	-	RHB9-B		EB9-B	YB9-B
	PX200-ARC	200	-	RHB9-B		EB9-B	YB9-B
	PX200GS	200	-	RHB9-B		EB9-B	YB9-B
	PX80 E	80	-	RHB9-B		EB9-B	YB9-B
	Quartz	50	93-98	RHB4L-B	0012180	EB4L-B	YB4L-B
	RCR	50	-	RHB4L-B	0012180	EB4L-B	YB4L-B
RS 125 ES, RACING	125	-	RHB9-B		EB9-B	YB9-B	

BATTERIE MOTO - ATV, UTV - MARINE

MARCA MAKE	MODELLO MODEL	CC CC	ANNO YEAR	BATTERIA RHIAG RHIAG BATTERY	BATTERIA MPT MOTORPARTS BATTERY	BATTERIA EXIDE EXIDE BATTERY	BATTERIA YUASA YUASA BATTERY
PIAGGIO	RUNN 50 IN REPLICA UK	50	-	RHB9-B		EB9-B	YB9-B
	Runner 125	125	-	RHB9-B		EB9-B	YB9-B
	RUNNER 125 E2	125	-	RHB9-B		EB9-B	YB9-B
	Runner 125 VX 4T	125	07	RHTX12-BS/RHB9-B	0012320	ETX12-BS/EB9-B	YTX12-BS/YB9-B
	Runner 125 VX 4T - ST (Euro 3)	125	-	RHTX12-BS	0012320	ETX12-BS	YTX12-BS
	Runner 180 2T	180	-	RHB9-B		EB9-B	YB9-B
	Runner 180 4T	180	07-	RHTX12-BS	0012320	ETX12-BS	YTX12-BS
	Runner 200 VXR 4T-ST (Euro 3)	200	-	RHTX12-BS	0012320	ETX12-BS	YTX12-BS
	Runner 4T	200	-	RHB10L-B-P	0012480	EB10L-B	YB10L-B
	Runner Iniez. PureJet	50	-	RHB9-B		EB9-B	YB9-B
	Runner Iniez. Europa	50	-	RHB9-B		EB9-B	YB9-B
	Runner Iniez. UK	50	-	RHB9-B		EB9-B	YB9-B
	Runner Poggiali	50	-	RHTX4L-BS	0012310	ETX4L-BS	YTX4L-BS
	Runner REPLICA	50	-	RHB9-B		EB9-B	YB9-B
	Runner SP Race	50	-	RHB4L-B	0012180	EB4L-B	YB4L-B
	Runner SP SC	50	-	RHB4L-B	0012180	EB4L-B	YB4L-B
	Runner SP, DD, FL	50	-	RHB4L-B	0012180	EB4L-B	YB4L-B
	Runner VXR 4T, RST	200	-	RHTX12-BS/RHB10L-B-P	0012320/0012480	ETX12-BS/EB10L-B	YTX12-BS/YB10L-B
	Runner, DT, DD, 4T, VX	125	-	RHB9-B		EB9-B	YB9-B
	Scatto	50	-	RHB4L-B	0012180	EB4L-B	YB4L-B
	Sfera	50	93-98	RHB4L-B	0012180	EB4L-B	YB4L-B
	Sfera	80	93-95	RHB4L-B	0012180	EB4L-B	YB4L-B
	Sfera	125	96-98	RHB9-B		EB9-B	YB9-B
	Sfera 4T	125	96-98	RHTX7L-BS	0012430	ETX7L-BS	YTX7L-BS
	Sfera RST	125	-	RHTX9-BS/RHB9-B	0012330	ETX9-BS/EB9-B	YTX9-BS/YB9-B
	Skipper	125	-	RHB9-B		EB9-B	YB9-B
	Skipper	125	-	RHB9-B		EB9-B	YB9-B
	Skipper	150	-	RHB4L-B	0012180	EB4L-B	YB4L-B
	Skipper 125 2T	125	-	RHB9-B		EB9-B	YB9-B
	Skipper 150 2T	150	-	RHB9-B		EB9-B	YB9-B
	Skipper LX/ST 4T	125	99	RHB9-B		EB9-B	YB9-B
	Skipper LX/ST 4T	150	99-	RHB9-B		EB9-B	YB9-B
	SKR	80	99	RHB5L-B	0012240	EB5L-B	YB5L-B
	SKR	150	-	RHB9-B		EB9-B	YB9-B
	SMT	50	-	RHB4L-B	0012180	EB4L-B	YB4L-B
	SP 50	50	10-	RHB4L-B	0012180	EB4L-B	YB4L-B
	SR 50 PureJet	50	-	RHB9-B		EB9-B	YB9-B
	ST4 Leader	125	00-	RHTX9-BS	0012330	ETX9-BS	YTX9-BS
	Stalker 50	50	-	RHTX4L-BS/RHB4L-B	0012310/0012180	ETX4L-BS/EB4L-B	YTX4L-BS/YB4L-B
	Stalker Naked	50	-	RHB4L-B	0012180	EB4L-B	YB4L-B
	Superhexagon GTX	125	00-	RHTX12-BS	0012320	ETX12-BS	YTX12-BS
	Superhexagon GTX	250	-99	RHB10L-B-P	0012480	EB10L-B	YB10L-B
	Superhexagon GTX	250	00	RHTX12-BS	0012320	ETX12-BS	YTX12-BS
	Superhexagon GXT	180	01-	RHTX12-BS	0012320	ETX12-BS	YTX12-BS
	Typhoon	80	95-96	RHB5L-B	0012240	EB5L-B	YB5L-B
	TpH	50	-	RHB4L-B	0012180	EB4L-B	YB4L-B
	Typhoon	50	09	RHB9-B		EB9-B	YB9-B
Typhoon	50	94-08	RHB4L-B	0012180	EB4L-B	YB4L-B	
Typhoon	150	-	RHTX9-BS	0012330	ETX9-BS	YTX9-BS	
Typhoon 50 Canada	50	-	RHB9-B		EB9-B	YB9-B	
Typhoon 50 USA	50	-	RHB9-B		EB9-B	YB9-B	

MARCA	MODELLO	CC	ANNO	BATTERIA RHIAG	BATTERIA MPT	BATTERIA EXIDE	BATTERIA YUASA
MAKE	MODEL	CC	YEAR	RHIAG BATTERY	MOTORPARTS BATTERY	EXIDE BATTERY	YUASA BATTERY
PIAGGIO	V.125 ET4 EURO2 EUROPA	125	-	RHB9-B		EB9-B	YB9-B
	V.PX 200 AUSTRALIA '05	200	-	RHB9-B		EB9-B	YB9-B
	Velofax	25	-98	RHB4L-B	0012180	EB4L-B	YB4L-B
	Velofax	50	-98	RHB4L-B	0012180	EB4L-B	YB4L-B
	Vespa GT	125	03-04	RHB10L-B-P	0012480	EB10L-B	YB10L-B
	Vespa 150 LX CANADA 2007	150	-	RHB9-B		EB9-B	YB9-B
	Vespa 150 LX USA 2007	150	-	RHB9-B		EB9-B	YB9-B
	Vespa 151 ET4 EURO2 EUROPA	150	-	RHB9-B		EB9-B	YB9-B
	Vespa ET2 Injection	50	-98	RHB5L-B	0012240	EB5L-B	YB5L-B
	Vespa ET4	50	-	RHB9-B		EB9-B	YB9-B
	Vespa ET4	125	-99	RHB9-B		EB9-B	YB9-B
	Vespa ET4	150	99-	RHB9-B		EB9-B	YB9-B
	Vespa ET4 Euro 2	50	-	RHB9-B		EB9-B	YB9-B
	Vespa FL	125	-	RHB9-B		EB9-B	YB9-B
	Vespa Grant	200	04	RHB10L-B-P	0012480	EB10L-B	YB10L-B
	Vespa Grant 125	125	03-04	RHB10L-B-P	0012480	EB10L-B	YB10L-B
	Vespa Granturismo	125	-	RHB9-B		EB9-B	YB9-B
	Vespa GT	200	04	RHB10L-B-P	0012480	EB10L-B	YB10L-B
	Vespa GT 60,GTS	250	05-08	RHB10L-B-P	0012480	EB10L-B	YB10L-B
	Vespa GT H20, UK	125	-	RHB9-B		EB9-B	YB9-B
	Vespa GTS ie Super	300	10-	RHTX14-BS	0012390	ETX14-BS	YTX14-BS
	Vespa GTS Super	300	08-10	RHTX14-BS	0012390	ETX14-BS	YTX14-BS
	Vespa GTS/GTV	125	07-08	RHB10L-B-P	0012480	EB10L-B	YB10L-B
	Vespa GTS/GTV	250	10-	RHTX14-BS	0012390	ETX14-BS	YTX14-BS
	Vespa GTV	250	08	RHTX14-BS	0012390	ETX14-BS	YTX14-BS
	Vespa GTV	250	06-07	RHB10L-B-P	0012480	EB10L-B	YB10L-B
	Vespa GTV 125 4T Navy (Euro 3)	125	-	RHTX12-BS	0012320	ETX12-BS	YTX12-BS
	Vespa GTV 4T Navy, LXV	125	-	RHTX12-BS	0012320	ETX12-BS	YTX12-BS
	Vespa GTV ie Navy	250	-	RHTX14-BS	0012390	ETX14-BS	YTX14-BS
	Vespa LX	125	05-08	RHB10L-B-P	0012480	EB10L-B	YB10L-B
	Vespa LX	150	05-08	RHB10L-B-P	0012480	EB10L-B	YB10L-B
	Vespa LX 2T	50	05-08	RHB4L-B	0012180	EB4L-B	YB4L-B
	Vespa LX 4T	50	05-08	RHB9-B		EB9-B	YB9-B
	Vespa LX Touring	125	10-	RHTX12-BS	0012320	ETX12-BS	YTX12-BS
	Vespa LX Touring	150	10-	RHTX12-BS	0012320	ETX12-BS	YTX12-BS
	Vespa LXV 125 4T Navy (Euro 3)	125	-	RHTX12-BS	0012320	ETX12-BS	YTX12-BS
	Vespa LXV ie 125 4T	125	10-	RHTX12-BS	0012320	ETX12-BS	YTX12-BS
	Vespa LXV2T	50	06-08	RHB9-B		EB9-B	YB9-B
	Vespa P E	200	-	RHB9-B		EB9-B	YB9-B
	Vespa PK Marce A.EL	50	-	RHTX5L-BS/RHB5L-B	0012380/0012240	ETX5L-BS/EB5L-B	YTX5L-BS/YB5L-B
	Vespa Primavera 2T	50	13-	RHB4L-B	0012180	EB4L-B	YB4L-B
	Vespa Primavera 4T	50	13-	RHTX7L-BS	0012430	ETX7L-BS	YTX7L-BS
	Vespa Primavera 4T	150	13-	RHTX7L-BS	0012430	ETX7L-BS	YTX7L-BS
	Vespa PX	50	-	RHB9-B		EB9-B	YB9-B
	Vespa PX 125 E2	125	-	RHB9-B		EB9-B	YB9-B
	Vespa PX 125 E2 BELGIO 05	125	-	RHB9-B		EB9-B	YB9-B
	Vespa PX 150 USA	150	-	RHB9-B		EB9-B	YB9-B
Vespa PX 151 E2	150	-	RHB9-B		EB9-B	YB9-B	
Vespa PX E	125	-98	RHB9-B		EB9-B	YB9-B	
Vespa PX E	150	-	RHB9-B		EB9-B	YB9-B	
Vespa PX E Lusso	200	-98	RHB9-B		EB9-B	YB9-B	

BATTERIE MOTO - ATV, UTV - MARINE

MARCA MAKE	MODELLO MODEL	CC CC	ANNO YEAR	BATTERIA RHIAG RHIAG BATTERY	BATTERIA MPT MOTORPARTS BATTERY	BATTERIA EXIDE EXIDE BATTERY	BATTERIA YUASA YUASA BATTERY
PIAGGIO	Vespa S	50	07-08	RHB9-B		EB9-B	YB9-B
	Vespa S	125	07-08	RHB10L-B-P	0012480	EB10L-B	YB10L-B
	X Evo	125	-	RHTX14-BS	0012390	ETX14-BS	YTX14-BS
	X Evo 400 (Euro 3)	401	-	RHTX14-BS	0012390	ETX14-BS	YTX14-BS
	X Evo, X8	400	-	RHTX14-BS	0012390	ETX14-BS	YTX14-BS
	X Evo, X7, X8, X9	250	04-08	RHTX14-BS	0012390	ETX14-BS	YTX14-BS
	X7	125	08	RHB10L-B-P	0012480	EB10L-B	YB10L-B
	X8	125	-	RHB10L-B-P	0012480	EB10L-B	YB10L-B
	X8	150	06-08	RHB10L-B-P	0012480	EB10L-B	YB10L-B
	X8	200	05-07	RHB10L-B-P	0012480	EB10L-B	YB10L-B
	X8 125 Premium (Euro 3)	125	-	RHTX14-BS	0012390	ETX14-BS	YTX14-BS
	X8 400 ie (Euro 3)	401	-	RHTX14-BS	0012390	ETX14-BS	YTX14-BS
	X8 Premium/Street	125	-	RHB10L-B-P	0012480	EB10L-B	YB10L-B
	X9	125	00-	RHB10L-B-P	0012480	EB10L-B	YB10L-B
	X9	180	01-	RHB10L-B-P	0012480	EB10L-B	YB10L-B
	X9	200	02-03	RHB10L-B-P	0012480	EB10L-B	YB10L-B
	X9	250	01-	RHTX12-BS	0012320	ETX12-BS	YTX12-BS
	X9	460	09	RHTX14-BS	0012390	ETX14-BS	YTX14-BS
	X9 Evolution	125	03-06	RHB9-B		EB9-B	YB9-B
	X9 Evolution	250	04	RHB10L-B-P	0012480	EB10L-B	YB10L-B
	X9 Evolution Eu3	125	07	RHB10L-B-P	0012480	EB10L-B	YB10L-B
	X9 Evolution USA	500	-	RHTX14-BS	0012390	ETX14-BS	YTX14-BS
	Zip 4 Tempi Euro 2	50	-	RHTX7L-BS	0012430	ETX7L-BS	YTX7L-BS
	Zip 4T	50	00-	RHTX9-BS	0012330	ETX9-BS	YTX9-BS
	Zip 4T	125	00-	RHTX9-BS	0012330	ETX9-BS	YTX9-BS
	Zip Bimodale	50	94-97	RHB4L-B	0012180	EB4L-B	YB4L-B
	Zip cat. 2T	50	00-	RHTX9-BS	0012330	ETX9-BS	YTX9-BS
	Zip FR/RST	50	-	RHB4L-B	0012180	EB4L-B	YB4L-B
	Zip SP	50	96-08	RHB4L-B	0012180	EB4L-B	YB4L-B
	Zip/Zip Fast Rider	50	-	RHB4L-B	0012180	EB4L-B	YB4L-B
POLARIS	8-Ball, Hammer	1507	03-05	RHTX20L-BS	0012640		YTX20L-BS
	Kingpin, Vegas	1507	03-05	RHTX20L-BS	0012640		YTX20L-BS
	V92C, DC Classic, Deluxe Cruiser	1507	98-04	RHTX20L-BS	0012640		YTX20L-BS
	V92DC Deluxe Cruiser	1507	01-03	RHTX20L-BS	0012640		YTX20L-BS
	V92SC Sport Cruiser	1507	00-01	RHTX20L-BS	0012640		YTX20L-BS
	V92TC Toring Cruiser	1507	02-06	RHTX20L-BS	0012640		YTX20L-BS
	Vegas	1507	-	RHTX20L-BS	0012640		YTX20L-BS
	Victory	1507	98-99	RHTX20L-BS	0012640		YTX20L-BS
	Victory 8-Ball/Harlen Ness	1507	04-05	RHTX20L-BS	0012640		YTX20L-BS
	PUCH	Byte AT10	50	-	RHB4L-B	0012180	EB4L-B
Carosello		50	-	RHB4L-B	0012180	EB4L-B	YB4L-B
Cobra GT, GTL		50	-	RHB4L-B	0012180	EB4L-B	YB4L-B
Hacker AT12, LC		50	-	RHB4L-B	0012180	EB4L-B	YB4L-B
Hacker AT12, LC/Racing		50	-	RHB4L-B	0012180	EB4L-B	YB4L-B
Lido SE		80	-	RHB5L-B	0012240	EB5L-B	YB5L-B
Lido SL, Lido Vario		50	-	RHB4L-B	0012180	EB4L-B	YB4L-B
SANYANG	Attila	150	99	RHTX7A-BS	0012350	ETX7A-BS	YTX7A-BS
	Big Wheel, Fancy	50	96	RHTX4L-BS	0012310	ETX4L-BS	YTX4L-BS
	Duke	125	95-96	RHTX7A-BS	0012350	ETX7A-BS	YTX7A-BS
	Free. Jet, Jungle	50	97	RHTX4L-BS	0012310	ETX4L-BS	YTX4L-BS
	Husky	125	96-99	RHTX7L-BS	0012430	ETX7L-BS	YTX7L-BS

MARCA	MODELLO	CC	ANNO	BATTERIA RHIAG	BATTERIA MPT	BATTERIA EXIDE	BATTERIA YUASA
MAKE	MODEL	CC	YEAR	RHIAG BATTERY	MOTORPARTS BATTERY	EXIDE BATTERY	YUASA BATTERY
SANYANG	Pure	50	99	RHTX4L-BS	0012310	ETX4L-BS	YTX4L-BS
	Super Duke	125	96-99	RHTX7L-BS	0012430	ETX7L-BS	YTX7L-BS
	Super Duke, Duke	150	99	RHTX7A-BS	0012350	ETX7A-BS	YTX7A-BS
SIMSON	Super Fancy	50	96-97	RHTX4L-BS	0012310	ETX4L-BS	YTX4L-BS
	Albatros El. Starter	50	97-01	RHB5L-B	0012240	EB5L-B	YB5L-B
	S7 Schwalbe	50	-	RHB5L-B	0012240	EB5L-B	YB5L-B
	Spatz	50	01	RHB4L-B	0012180	EB4L-B	YB4L-B
	SR50 2CE El. Starter	50	93-95	RHB5L-B	0012240	EB5L-B	YB5L-B
	SR50 CC El. -Starter	50	94	RHB5L-B	0012240	EB5L-B	YB5L-B
	SR50 XCE, XGE, El. -Start	50	95	RHB5L-B	0012240	EB5L-B	YB5L-B
	SR80 2CE El.-Starter	80	93	RHB5L-B	0012240	EB5L-B	YB5L-B
	SR80 CCE El.-Starter	80	94	RHB5L-B	0012240	EB5L-B	YB5L-B
	SR80 XCE,XGE	80	95	RHB5L-B	0012240	EB5L-B	YB5L-B
	(El. Starter)	400	72-75	RHB5L-B	0012240	EB5L-B	YB5L-B
	SUZUKI	AD50	50	91-95	RHTX4L-BS	0012310	ETX4L-BS
Address 50		50	-97	RHTX4L-BS	0012310	ETX4L-BS	YTX4L-BS
AE50, 50M		50	91-95	RHTX4L-BS	0012310	ETX4L-BS	YTX4L-BS
AG100		100	91-95	RHTX5L-BS	0012380	ETX5L-BS	YTX5L-BS
AG50T		50	95	RHTX4L-BS	0012310	ETX4L-BS	YTX4L-BS
AH100 Address		100	95-96	RHTX5L-BS	0012380	ETX5L-BS	YTX5L-BS
AH50		50	92-95	RHTX4L-BS	0012310	ETX4L-BS	YTX4L-BS
AJ50		50	95	RHTX4L-BS	0012310	ETX4L-BS	YTX4L-BS
AN		125	-	RHTX7A-BS	0012350	ETX7A-BS	YTX7A-BS
AN Burgman		125	-	RHTX9-BS	0012330	ETX9-BS	YTX9-BS
AN Burgman		150	03-	RHTX9-BS	0012330	ETX9-BS	YTX9-BS
AN T-Y		150	96-00	RHTX7A-BS	0012350	ETX7A-BS	YTX7A-BS
AN125(Vecstar)		125	02-	RHTX7A-BS	0012350	ETX7A-BS	YTX7A-BS
AN125(Vecstar)		125	95-96	RHTX7A-BS	0012350	ETX7A-BS	YTX7A-BS
AN150 Burgman		150	-98	RHTX7A-BS	0012350	ETX7A-BS	YTX7A-BS
AN150 Burgman		150	02-	RHTX7A-BS	0012350	ETX7A-BS	YTX7A-BS
AN250 Burgman		250	99	RHTX7A-BS	0012350	ETX7A-BS	YTX7A-BS
AN250 Burgman		250	00-02	RHTX9-BS	0012330	ETX9-BS	YTX9-BS
AN250 Burgman		250	03-	RHT12A-BS	0012470	ET12A-BS	YT12A-BS
AN250 Burgman		250	03-	RHTX12-BS	0012320	ETX12-BS	YTX12-BS
AN250 Sky Wave		250	98	RHTX7A-BS	0012350	ETX7A-BS	YTX7A-BS
AN400 Burgman		400	03-10	RHTX9-BS/RHT12A-BS	0012330/0012470	ETX9-BS/ET12A-BS	YTX9-BS/YT12A-BS
AN400 Burgman		400	03-	RHT12A-BS	0012470	ET12A-BS	YT12A-BS
AN400 Burgman		400	99-02	RHTX9-BS	0012330	ETX9-BS	YTX9-BS
AN650 ABS Burgman		650	04	RHTX14-BS	0012390	ETX14-BS	YTX14-BS
AN650 BURGMAN		650	02-10	RHTX14-BS	0012390	ETX14-BS	YTX14-BS
AP50, R7		50	94-97	RHB4L-B/RHTX4L-BS	0012310/0012180	ETX4L-BS/EB4L-B	YTX4L-BS/YB4L-B
AY A K5-K6		50	05-06	RHTX5L-BS	0012380	ETX5L-BS	YTX5L-BS
AY50, W, WR Katana		50	-98	RHTX4L-BS	0012310	ETX4L-BS	YTX4L-BS
Bandit1200S		1200	02-06	RHTX12-BS	0012320	ETX12-BS	YTX12-BS
CP50		50	85-95	RHB4L-B	0012180	EB4L-B	YB4L-B
CP80		80	92	RHB5L-B	0012240	EB5L-B	YB5L-B
CS90G	90	91	RHB5L-B	0012240	EB5L-B	YB5L-B	
DG80	80	91	RHB4L-B	0012180	EB4L-B	YB4L-B	
DL V Storm	650	04-10	RHTX12-BS	0012320	ETX12-BS	YTX12-BS	
DL1000 V-STROM	1000	02-10	RHTX14-BS	0012390	ETX14-BS	YTX14-BS	
DR 125 SM	125	12	RHTX7L-BS	0012430	ETX7L-BS	YTX7L-BS	

BATTERIE MOTO - ATV, UTV - MARINE

MARCA MAKE	MODELLO MODEL	CC CC	ANNO YEAR	BATTERIA RHIAG RHIAG BATTERY	BATTERIA MPT MOTORPARTS BATTERY	BATTERIA EXIDE EXIDE BATTERY	BATTERIA YUASA YUASA BATTERY
SUZUKI	DR R N-P	650	92-93	RHTX4L-BS	0012310	ETX4L-BS	YTX4L-BS
	DR R R-S	650	94-95	RHTX12-BS	0012320	ETX12-BS	YTX12-BS
	DR R/RS L-M	650	90-91	RHB5L-B	0012240	EB5L-B	YB5L-B
	DR-Z250	250	01-07	RHTZ7S-BS/RHTX5L-BS	0012380	ETX5L-BS	YTX5L-BS
	DR-Z400, E, S, SM	400	00-10	RHT7B-BS	0012520	ET7B-BS	YT7B-BS
	DR125, D, S	125	-	RHB4L-B	0012180	EB4L-B	YB4L-B
	DR200SE	200	96-10	RHTX7L-BS	0012430	ETX7L-BS	YTX7L-BS
	DR200SE	200	96-99	RHTX7L-BS	0012430	ETX7L-BS	YTX7L-BS
	DR250	250	-01	RHTX5L-BS/RHTZ7S-BS	0012380	ETX5L-BS	YTX5L-BS
	DR250S	250	-87	RHB4L-B	0012180	EB4L-B	YB4L-B
	DR250S	250	90-92	RHTX4L-BS	0012310	ETX4L-BS	YTX4L-BS
	DR250S (Europe)	250	90-95	RHTX7L-BS	0012430	ETX7L-BS	YTX7L-BS
	DR250S EP, ER, ES	250	93-95	RHTX7L-BS	0012430	ETX7L-BS	YTX7L-BS
	DR350S, SH	350	91-99	RHTX4L-BS	0012310	ETX4L-BS	YTX4L-BS
	DR350SE	350	94-99	RHTX7L-BS	0012430	ETX7L-BS	YTX7L-BS
	DR500S	500	92	RHB4L-B	0012180	EB4L-B	YB4L-B
	DR600R, RU, S, SU	600	85-89	RHB5L-B	0012240	EB5L-B	YB5L-B
	DR650R, RU	650	90-91	RHB5L-B	0012240	EB5L-B	YB5L-B
	DR650R, RU	650	92-94	RHTX4L-BS	0012310	ETX4L-BS	YTX4L-BS
	DR650RE, REU	650	94-95	RHTX12-BS	0012320	ETX12-BS	YTX12-BS
	DR650RS, RSU	650	90-91	RHB5L-B	0012240	EB5L-B	YB5L-B
	DR650RSE, RSEU	650	91-	RHTX14-BS	0012390	ETX14-BS	YTX14-BS
	DR650S	650	90-91	RHB5L-B	0012240	EB5L-B	YB5L-B
	DR650S ER, ES	650	94-95	RHTX12-BS	0012320	ETX12-BS	YTX12-BS
	DR650S, N, P	650	92-93	RHTX4L-BS	0012310	ETX4L-BS	YTX4L-BS
	DR650SE (Canada)	650	96-97	RHTX9-BS	0012330	ETX9-BS	YTX9-BS
	DR650SE, SEU	650	98-10	RHTX9-BS	0012330	ETX9-BS	YTX9-BS
	DR650SEE, SEU	650	91-04	RHTX9-BS	0012330	ETX9-BS	YTX9-BS
	DR650SES	650	95-	RHTX12-BS	0012320	ETX12-BS	YTX12-BS
	DR800S, SU Big	800	91-	RHTX14-BS	0012390	ETX14-BS	YTX14-BS
	DZ125	125	02-	RHTX7L-BS	0012430	ETX7L-BS	YTX7L-BS
	Epicuro	125	-	RHTX7A-BS	0012350	ETX7A-BS	YTX7A-BS
	FB100	100	91	RHB5L-B	0012240	EB5L-B	YB5L-B
	FB50, M	50	02-	RHTX4L-BS	0012310	ETX4L-BS	YTX4L-BS
	FB50, M	50	91-95	RHTX4L-BS	0012310	ETX4L-BS	YTX4L-BS
	FB80, M	80	91-95	RHTX4L-BS	0012310	ETX4L-BS	YTX4L-BS
	FB80D	80	95	RHTX5L-BS	0012380	ETX5L-BS	YTX5L-BS
	FB90	90	02-	RHTX4L-BS	0012310	ETX4L-BS	YTX4L-BS
	FE50	50	-	RHTX4L-BS	0012310	ETX4L-BS	YTX4L-BS
	FR80	80	95	RHTX4L-BS	0012310	ETX4L-BS	YTX4L-BS
	GFS1250-FA	1250	11-	RHT12A-BS	0012470	ET12A-BS	YT12A-BS
	GS1100G	1100	91-95	RHTX14-BS	0012390	ETX14-BS	YTX14-BS
	GS1200SS	1200	02-	RHTX12-BS	0012320	ETX12-BS	YTX12-BS
	GS400, E	400	91	RHTX9-BS	0012330	ETX9-BS	YTX9-BS
	GS400X	400	91-95	RHTX9-BS	0012330	ETX9-BS	YTX9-BS
	GS50	50	-	RHTX4L-BS	0012310	ETX4L-BS	YTX4L-BS
	GS550ES, E, L	550	83-86	RHB10L-B-P	0012480	EB10L-B	YB10L-B
GSF Bandit	400	91-93	RHTX9-BS	0012330	ETX9-BS	YTX9-BS	
GSF Bandit	1250	07-08	RHT12A-BS	0012470	ET12A-BS	YT12A-BS	
GSF S Bandit	650	05-08	RHTX9-BS	0012330	ETX9-BS	YTX9-BS	
GSF1200, S, SA Bandit	1200	96-05	RHTX12-BS	0012320	ETX12-BS	YTX12-BS	

MARCA	MODELLO	CC	ANNO	BATTERIA RHIAG	BATTERIA MPT	BATTERIA EXIDE	BATTERIA YUASA
MAKE	MODEL	CC	YEAR	RHIAG BATTERY	MOTORPARTS BATTERY	EXIDE BATTERY	YUASA BATTERY
SUZUKI	GSF1250 FA	1250	10-	RHT12A-BS	0012470	ET12A-BS	YT12A-BS
	GSF1250S, A BANDIT	1250	07-10	RHT12A-BS	0012470	ET12A-BS	YT12A-BS
	GSF250	250	95	RHTX7A-BS	0012350	ETX7A-BS	YTX7A-BS
	GSF400 M	400	-	RHTX9-BS	0012330	ETX9-BS	YTX9-BS
	GSF600, S, SU, U, UII BANDIT	600	02-	RHTX9-BS	0012330	ETX9-BS	YTX9-BS
	GSF600, S, SU, U, UII BANDIT	600	95-	RHTX9-BS	0012330	ETX9-BS	YTX9-BS
	GSF650/U	650	-	RHTX9-BS	0012330	ETX9-BS	YTX9-BS
	GSR 750 (ABS)	750	12	RHT12A-BS	0012470	ET12A-BS	YT12A-BS
	GSR150i	150	11-	RHTX7L-BS	0012430	ETX7L-BS	YTX7L-BS
	GSR400	400	-	RHTX9-BS	0012330	ETX9-BS	YTX9-BS
	GSR600	600	-03	RHTX9-BS	0012330	ETX9-BS	YTX9-BS
	GSX 750WR	750	94-95	RHTX9-BS	0012330	ETX9-BS	YTX9-BS
	GSX B-Kng	1300	08	RHTX12-BS	0012320	ETX12-BS	YTX12-BS
	GSX F	600	98-06	RHTX9-BS	0012330	ETX9-BS	YTX9-BS
	GSX F	650	08	RHTX9-BS	0012330	ETX9-BS	YTX9-BS
	GSX F	750	01-06	RHTX9-BS	0012330	ETX9-BS	YTX9-BS
	GSX K6-K8	600	06-08	RHTX9-BS	0012330	ETX9-BS	YTX9-BS
	GSX W	750	98-01	RHTX9-BS	0012330	ETX9-BS	YTX9-BS
	GSX-R 600 V, W	600	-97	RHTX12-BS	0012320	ETX12-BS	YTX12-BS
	GSX-R 600 V, W	600	02-	RHTX9-BS	0012330	ETX9-BS	YTX9-BS
	GSX-R1000	1000	01-04	RHTX12-BS	0012320	ETX12-BS	YTX12-BS
	GSX-R1000	1000	05-10	RHT12A-BS	0012470	ET12A-BS	YT12A-BS
	GSX-R1100W	1100	93-99	RHTX12-BS	0012320	ETX12-BS	YTX12-BS
	GSX-R400R, RF	400	91-95	RHTX9-BS	0012330	ETX9-BS	YTX9-BS
	GSX-R600	600	11-	RHTX9-BS	0012330	ETX9-BS	YTX9-BS
	GSX-R600	600	97-10	RHTX9-BS	0012330	ETX9-BS	YTX9-BS
	GSX-R600W	600	92-93	RHTX9-BS	0012330	ETX9-BS	YTX9-BS
	GSX-R750	750	00-11	RHT12A-BS	0012470	ET12A-BS	YT12A-BS
	GSX-R750	750	96-99	RHTX9-BS	0012330	ETX9-BS	YTX9-BS
	GSX-R750, W	750	92-93	RHTX12-BS	0012320	ETX12-BS	YTX12-BS
	GSX-R750, W	750	94-96	RHTX9-BS	0012330	ETX9-BS	YTX9-BS
	GSX1100G	1100	91-93	RHTX14-BS	0012390	ETX14-BS	YTX14-BS
	GSX1200	1200	99	RHTX12-BS	0012320	ETX12-BS	YTX12-BS
	GSX1300R, Hayabusa	1300	08	RHTX12-BS	0012320	ETX12-BS	YTX12-BS
	GSX1300R, Hayabusa	1300	99-07	RHT12A-BS	0012470	ET12A-BS	YT12A-BS
	GSX1400	1400	02-	RHTX14-BS	0012390	ETX14-BS	YTX14-BS
	GSX250F, S	250	91-95	RHTX7A-BS	0012350	ETX7A-BS	YTX7A-BS
	GSX400	400	-	RHTX9-BS	0012330	ETX9-BS	YTX9-BS
	GSX400FS Inazuma	400	02-	RHTX7A-BS	0012350	ETX7A-BS	YTX7A-BS
	GSX550	550	94	RHB10L-B-P	0012480	EB10L-B	YB10L-B
	GSX550E, L, ES, EF, EV	550	-92	RHB10L-B-P	0012480	EB10L-B	YB10L-B
	GSX600F Katana	600	98-06	RHTX9-BS	0012330	ETX9-BS	YTX9-BS
	GSX650/F	650	-	RHTX9-BS	0012330	ETX9-BS	YTX9-BS
	GSX750	750	99-	RHTX9-BS	0012330	ETX9-BS	YTX9-BS
	GSX750, F	750	98-99	RHTX9-BS	0012330	ETX9-BS	YTX9-BS
GSX750F Katana	750	98-06	RHTX9-BS	0012330	ETX9-BS	YTX9-BS	
GSX750P	750	-	RHTX12-BS	0012320	ETX12-BS	YTX12-BS	
GT125, E, T, ET	125	74-79	RHB5L-B	0012240	EB5L-B	YB5L-B	
GT250, E Hustler	250	-81	RHB5L-B	0012240	EB5L-B	YB5L-B	
GZ125 Marauder	125	98-04	RHTX7L-BS	0012430	ETX7L-BS	YTX7L-BS	
GZ250	250	99-08	RHTX7L-BS	0012430	ETX7L-BS	YTX7L-BS	

BATTERIE MOTO - ATV, UTV - MARINE

MARCA MAKE	MODELLO MODEL	CC CC	ANNO YEAR	BATTERIA RHIAG RHIAG BATTERY	BATTERIA MPT MOTORPARTS BATTERY	BATTERIA EXIDE EXIDE BATTERY	BATTERIA YUASA YUASA BATTERY
SUZUKI	GZ250 Marauder	250	99-10	RHTX7L-BS	0012430	ETX7L-BS	YTX7L-BS
	HJ125T-9	125	-	RHTX7A-BS	0012350	ETX7A-BS	YTX7A-BS
	HS125T	125	-	RHTX7L-BS	0012430	ETX7L-BS	YTX7L-BS
	Inazuma 250	250	12	RHTX9-BS	0012330	ETX9-BS	YTX9-BS
	Intruder C800	800	12	RHTX12-BS	0012320	ETX12-BS	YTX12-BS
	Intruder M800	800	12	RHTX12-BS	0012320	ETX12-BS	YTX12-BS
	IntruderLC250	250	02-	RHTX7L-BS	0012430	ETX7L-BS	YTX7L-BS
	K125	125	91	RHB10L-B-P	0012480	EB10L-B	YB10L-B
	Katana 50LC	50	97	RHTX4L-BS	0012310	ETX4L-BS	YTX4L-BS
	PG Gamma	125	-	RHTX5L-BS	0012380	ETX5L-BS	YTX5L-BS
	RC50	50	02-	RHTX4L-BS	0012310	ETX4L-BS	YTX4L-BS
	RF RR	900	-	RHTX9-BS	0012330	ETX9-BS	YTX9-BS
	RF600R, S	600	93-96	RHTX9-BS	0012330	ETX9-BS	YTX9-BS
	RF900R, S, ZS	900	94-97	RHTX9-BS	0012330	ETX9-BS	YTX9-BS
	RG125 F	125	92-95	RHTX5L-BS	0012380	ETX5L-BS	YTX5L-BS
	RG250C, E, FC	250	-92	RHB5L-B	0012240	EB5L-B	YB5L-B
	RG50	50	91	RHB4L-B	0012180	EB4L-B	YB4L-B
	RG500 Gamma	500	-92	RHTX5L-BS	0012380	ETX5L-BS	YTX5L-BS
	RG500 Gamma	500	94	RHTX5L-BS	0012380	ETX5L-BS	YTX5L-BS
	RG80, C	80	85-95	RHB4L-B	0012180	EB4L-B	YB4L-B
	RGV250 Gamma	250	91-95	RHTX4L-BS	0012310	ETX4L-BS	YTX4L-BS
	RV Van Van K3-K8	125	03-08	RHTX7L-BS	0012430	ETX7L-BS	YTX7L-BS
	RV125 SE, R	125	94	RHTX7L-BS	0012430	ETX7L-BS	YTX7L-BS
	RV125 Tracker	125	02-	RHTX7L-BS	0012430	ETX7L-BS	YTX7L-BS
	RV200	200	02-	RHTX7L-BS	0012430	ETX7L-BS	YTX7L-BS
	Scrambler TC305	305	69	RHB5L-B	0012240	EB5L-B	YB5L-B
	SFV650 GLAUDIUS	650	09-10	RHT12A-BS	0012470	ET12A-BS	YT12A-BS
	SIXteen 125	125	10-	RHTX7L-BS	0012430	ETX7L-BS	YTX7L-BS
	SP200	200	86-88	RHB4L-B	0012180	EB4L-B	YB4L-B
	SP250	250	92	RHB4L-B	0012180	EB4L-B	YB4L-B
	SP500	500	92	RHB4L-B	0012180	EB4L-B	YB4L-B
	SP6600	600	-85	RHB5L-B	0012240	EB5L-B	YB5L-B
	ST250	250	-	RHTX7L-BS	0012430	ETX7L-BS	YTX7L-BS
	SV 03	1000	-	RHTX14-BS	0012390	ETX14-BS	YTX14-BS
	SV X	650	99-02	RHT12A-BS	0012470	ET12A-BS	YT12A-BS
	SV1000, S	1000	03-07	RHTX14-BS	0012390	ETX14-BS	YTX14-BS
	SV400S	400	02-	RHTX9-BS	0012330	ETX9-BS	YTX9-BS
	SV650	650	99-02	RHT12A-BS	0012470	ET12A-BS	YT12A-BS
	SV650, S, A, SA	650	03-10	RHT12A-BS	0012470	ET12A-BS	YT12A-BS
	SV650/SV650S	650	03-10	RHTX12-BS	0012320	ETX12-BS	YTX12-BS
	SV650A/SV650SA	650	03-10	RHTX12-BS	0012320	ETX12-BS	YTX12-BS
	T20	250	69	RHB5L-B	0012240	EB5L-B	YB5L-B
	T200, TC200	200	-	RHB5L-B	0012240	EB5L-B	YB5L-B
	T250	250	72	RHB5L-B	0012240	EB5L-B	YB5L-B
	T250, T250-II, T250J, T250R	250	72	RHB5L-B	0012240	EB5L-B	YB5L-B
	T305	305	69	RHB5L-B	0012240	EB5L-B	YB5L-B
	T350-1, -2	350	79	RHB5L-B	0012240	EB5L-B	YB5L-B
T350J, R	350	79	RHB5L-B	0012240	EB5L-B	YB5L-B	
TC250 Scrambler	250	69	RHB5L-B	0012240	EB5L-B	YB5L-B	
TC305, T305 SCRAMBLER	305	69	RHB5L-B	0012240	EB5L-B	YB5L-B	
TL 1000S V	1000	02-	RHTX12-BS	0012320	ETX12-BS	YTX12-BS	

MARCA	MODELLO	CC	ANNO	BATTERIA RHIAG	BATTERIA MPT	BATTERIA EXIDE	BATTERIA YUASA
MAKE	MODEL	CC	YEAR	RHIAG BATTERY	MOTORPARTS BATTERY	EXIDE BATTERY	YUASA BATTERY
SUZUKI	TL 1000S V	1000	97-99	RHTX12-BS	0012320	ETX12-BS	YTX12-BS
	TL1000R	1000	98-03	RHT12A-BS	0012470	ET12A-BS	YT12A-BS
	TL1000S	1000	97-01	RHTX12-BS	0012320	ETX12-BS	YTX12-BS
	TL1100R, S	1100	98-03	RHT12A-BS	0012470	ET12A-BS	YT12A-BS
	TL1100S V	1100	97-01	RHTX12-BS	0012320	ETX12-BS	YTX12-BS
	TS125R, SZ	125	89-94	RHTX4L-BS	0012310	ETX4L-BS	YTX4L-BS
	TS125X	125	92	RHB4L-B	0012180	EB4L-B	YB4L-B
	TS185ER	185	02-	RHTX4L-BS	0012310	ETX4L-BS	YTX4L-BS
	TS200R, RM	200	91-92	RHTX4L-BS	0012310	ETX4L-BS	YTX4L-BS
	TS250X	250	-94	RHB4L-B	0012180	EB4L-B	YB4L-B
	TS400 Apache	400	72-75	RHB5L-B	0012240	EB5L-B	YB5L-B
	TS50W, XA, XK	50	91	RHB4L-B	0012180	EB4L-B	YB4L-B
	TS80X	80	84-87	RHB4L-B	0012180	EB4L-B	YB4L-B
	TU250G	250	-	RHTX7L-BS	0012430	ETX7L-BS	YTX7L-BS
	TU250X	250	09-10	RHTX7L-BS	0012430	ETX7L-BS	YTX7L-BS
	UC Epicuro X-K1	150	99-01	RHTX7A-BS	0012350	ETX7A-BS	YTX7A-BS
	UE	125	-	RHTX7A-BS	0012350	ETX7A-BS	YTX7A-BS
	UE CT K1	150	01	RHTX7A-BS	0012350	ETX7A-BS	YTX7A-BS
	UG110 Hokuto	110	00-	RHTX5L-BS	0012380	ETX5L-BS	YTX5L-BS
	UH Burgman	125	02-08	RHTX9-BS	0012330	ETX9-BS	YTX9-BS
	UH Burgman K7	200	07-08	RHTX9-BS	0012330	ETX9-BS	YTX9-BS
	UX Sixteen	125	08	RHTX7A-BS	0012350	ETX7A-BS	YTX7A-BS
	UX Sixteen K2-K6	150	02-06	RHTX9-BS	0012330	ETX9-BS	YTX9-BS
	UX Sixteen K8	150	08	RHTX7L-BS	0012430	ETX7L-BS	YTX7L-BS
	UX50 W Zillion	50	99	RHTX4L-BS	0012310	ETX4L-BS	YTX4L-BS
	UZ50X	50	06	RHTX4L-BS	0012310	ETX4L-BS	YTX4L-BS
	VL125 Intruder LC	125	00-07	RHTX7L-BS	0012430	ETX7L-BS	YTX7L-BS
	VL250	250	01-07	RHTX7L-BS	0012430	ETX7L-BS	YTX7L-BS
	VL400	400	-	RHTX12-BS	0012320	ETX12-BS	YTX12-BS
	VL800 BOULEVARD S50	800	01-10	RHTX12-BS	0012320	ETX12-BS	YTX12-BS
	VL800 Intruder Volusia	800	01-10	RHTX12-BS	0012320	ETX12-BS	YTX12-BS
	VL800 Intruder Volusia, Boulevard C50, T, M50	800	01-10	RHTX12-BS	0012320	ETX12-BS	YTX12-BS
	VS600 GLS	600	-	RHTX9-BS	0012330	ETX9-BS	YTX9-BS
	VZ Intruder M800	800	05-08	RHTX12-BS	0012320	ETX12-BS	YTX12-BS
	VZ400	400	02-	RHTX7A-BS	0012350	ETX7A-BS	YTX7A-BS
	VZ800 Marauder	800	97-08	RHTX12-BS	0012320	ETX12-BS	YTX12-BS
	X5	50	-	RHTX4L-BS	0012310	ETX4L-BS	YTX4L-BS
	XF650 Freewind	650	02-	RHTX9-BS	0012330	ETX9-BS	YTX9-BS
	XF650 Freewind	650	97-	RHTX9-BS	0012330	ETX9-BS	YTX9-BS
	ZZ50	50	97	RHTX4L-BS	0012310	ETX4L-BS	YTX4L-BS
SYM	Attila	125	99-00	RHTX7A-BS	0012350	ETX7A-BS	YTX7A-BS
	Attila	150	00-01	RHTX7A-BS	0012350	ETX7A-BS	YTX7A-BS
	Cinderella	100	99-01	RHTX7A-BS	0012350	ETX7A-BS	YTX7A-BS
	CITYCOM 300 EFI	300	10-	RHTZ10S-BS	0012540		YTZ10S-BS
	DD EU2	50	02-07	RHTX4L-BS	0012310	ETX4L-BS	YTX4L-BS
	Euro MX	150	02-04	RHTX9-BS	0012330	ETX9-BS	YTX9-BS
	Fiddle	50	10-	RHTX7A-BS	0012350	ETX7A-BS	YTX7A-BS
	Fiddle	125	-10	RHTX9-BS	0012330	ETX9-BS	YTX9-BS
	Fiddle	125	10-	RHTX7A-BS	0012350	ETX7A-BS	YTX7A-BS
	Fiddle II	50	10	RHTX7A-BS	0012350	ETX7A-BS	YTX7A-BS
	Fiddle II	125	08-10	RHTX7A-BS	0012350	ETX7A-BS	YTX7A-BS

BATTERIE MOTO - ATV, UTV - MARINE

MARCA MAKE	MODELLO MODEL	CC CC	ANNO YEAR	BATTERIA RHIAG RHIAG BATTERY	BATTERIA MPT MOTORPARTS BATTERY	BATTERIA EXIDE EXIDE BATTERY	BATTERIA YUASA YUASA BATTERY	
SYM	GTS 300 EFI	300	11-	RHTX12-BS	0012320	ETX12-BS	YTX12-BS	
	HD	125	-10	RHTX9-BS	0012330	ETX9-BS	YTX9-BS	
	HD	200	03-10	RHTX9-BS	0012330	ETX9-BS	YTX9-BS	
	Husky	125	99-00	RHTX7L-BS	0012430	ETX7L-BS	YTX7L-BS	
	Jet	50	99-01	RHTX4L-BS	0012310	ETX4L-BS	YTX4L-BS	
	Jet	100	99-00	RHTX5L-BS	0012380	ETX5L-BS	YTX5L-BS	
	Jet Euro 50	50	10	RHTZ75-BS	0012500		YTZ75-BS	
	Joymax	200	06-07	RHTX12-BS	0012320	ETX12-BS	YTX12-BS	
	Joyride	125	01-07	RHTX9-BS	0012330	ETX9-BS	YTX9-BS	
	Joyride	150	01-02	RHTX9-BS	0012330	ETX9-BS	YTX9-BS	
	Joyrider	200	03-08	RHTX9-BS	0012330	ETX9-BS	YTX9-BS	
	Jungle	50	99-00	RHTX4L-BS	0012310	ETX4L-BS	YTX4L-BS	
	Mask	50	00-04	RHTX4L-BS	0012310	ETX4L-BS	YTX4L-BS	
	MAXSYM 400I	400	11-	RHTZ145-BS	0012580		YTZ145-BS	
	Megalo	125	06-07	RHTX7A-BS	0012350	ETX7A-BS	YTX7A-BS	
	MIO 50	50	-10	RHTX7A-BS	0012350	ETX7A-BS	YTX7A-BS	
	New Duke	125	00-01	RHTX7A-BS	0012350	ETX7A-BS	YTX7A-BS	
	Red Devil	50	99-01	RHTX4L-BS	0012310	ETX4L-BS	YTX4L-BS	
	RS50	50	-	RHTX4L-BS	0012310	ETX4L-BS	YTX4L-BS	
	RV250	250	10	RHTX12-BS	0012320	ETX12-BS	YTX12-BS	
	Shark	125	99-02	RHTX9-BS	0012330	ETX9-BS	YTX9-BS	
	Shark	150	00-01	RHTX9-BS	0012330	ETX9-BS	YTX9-BS	
	Super Duke	125	99-02	RHTX7A-BS	0012350	ETX7A-BS	YTX7A-BS	
	Super Duke	150	99-02	RHTX9-BS	0012330	ETX9-BS	YTX9-BS	
	Super Fancy	50	98-00	RHTX4L-BS	0012310	ETX4L-BS	YTX4L-BS	
	Symphony	50	-11	RHTX7A-BS	0012350	ETX7A-BS	YTX7A-BS	
	Symply	50	07-10	RHTX7A-BS	0012350	ETX7A-BS	YTX7A-BS	
	Symply	125	07-08	RHTX7A-BS	0012350	ETX7A-BS	YTX7A-BS	
	VS	125	06	RHTX9-BS	0012330	ETX9-BS	YTX9-BS	
	VS	150	07	RHTX9-BS	0012330	ETX9-BS	YTX9-BS	
	VS Euro3	125	07-08	RHTX9-BS	0012330	ETX9-BS	YTX9-BS	
	VS Euro3	150	07-08	RHTX9-BS	0012330	ETX9-BS	YTX9-BS	
	TRIUMPH	600	650	00-03	RHTX12-BS	0012320	ETX12-BS	YTX12-BS
		America	865	09-10	RHT12B-BS	0012550	ET12B-BS	YT12B-BS
		Bonneville	800	01-05	RHTX12-BS	0012320	ETX12-BS	YTX12-BS
		Bonneville T100, SE	865	11-13	RHTX12-BS	0012320	ETX12-BS	YTX12-BS
		Bonneville T100, SE	865	09-10	RHT12B-BS	0012550	ET12B-BS	YT12B-BS
		Bonneville, Tiger	750	-	RHB9-B		EB9-B	YB9-B
		Daytona 600/650 Speed four	600	03-05	RHTX9-BS	0012330	ETX9-BS	YTX9-BS
		Daytona 675	675	06-11	RHT7B-BS	0012520	ET7B-BS	YT7B-BS
Daytona 675 R		675	11-	RHTX9-BS	0012330	ETX9-BS	YTX9-BS	
Daytona 955i		955	99-04	RHTX14-BS	0012390	ETX14-BS	YTX14-BS	
Rocket III		2300	03-10	RHTX20L-BS	0012640		YTX20L-BS	
Scrambler		865	11-13	RHTX12-BS	0012320	ETX12-BS	YTX12-BS	
Scrambler		865	09-10	RHT12B-BS	0012550	ET12B-BS	YT12B-BS	
Scrambler, Bonneville		900	06-07	RHTX12-BS	0012320	ETX12-BS	YTX12-BS	
Speed Triple		955	99-04	RHTX14-BS	0012390	ETX14-BS	YTX14-BS	
Speed Triple		1050	05-10	RHTX12-BS/RHT12A-BS	0012320/0012470	ETX12-BS/ET12A-BS	YTX12-BS/YT12A-BS	
Speedmaster		800	03-05	RHTX12-BS	0012320	ETX12-BS	YTX12-BS	
Speedmaster		865	09-10	RHT12B-BS	0012550	ET12B-BS	YT12B-BS	
Sprint ST	1050	05-12	RHT12A-BS/RHTX12-BS	0012320/0012470	ETX12-BS/ET12A-BS	YTX12-BS/YT12A-BS		

MARCA	MODELLO	CC	ANNO	BATTERIA RHIAG	BATTERIA MPT	BATTERIA EXIDE	BATTERIA YUASA
MAKE	MODEL	CC	YEAR	RHIAG BATTERY	MOTORPARTS BATTERY	EXIDE BATTERY	YUASA BATTERY
TRIUMPH	Sprint ST, RS	955	99-04	RHTX14-BS	0012390	ETX14-BS	YTX14-BS
	Street Triple, R	675	09-10	RHTX9-BS	0012330	ETX9-BS	YTX9-BS
	Thruxton	900	03-10	RHTX12-BS	0012320	ETX12-BS	YTX12-BS
	Thunderbird	1600	10-	RHTX20L-BS	0012640		YTX20L-BS
	Thunderbird Sport	885	-	RHTX14-BS	0012390	ETX14-BS	YTX14-BS
	Thunderbird Storm 1700 ABS	1700	11-	RHTX20L-BS	0012640		YTX20L-BS
	Tiger	885	99-01	RHTX14-BS	0012390	ETX14-BS	YTX14-BS
	Tiger	900	99-	RHTX14-BS	0012390	ETX14-BS	YTX14-BS
	Tiger	955	02-06	RHTX14-BS	0012390	ETX14-BS	YTX14-BS
	Tiger	1050	07-10	RHT12A-BS/RHTX12-BS	0012320/0012470	ETX12-BS/ET12A-BS	YTX12-BS/YT12A-BS
	Tiger Explorer	1215	12	RHTX20L-BS	0012640		YTX20L-BS
	Tiger SE	1050	12-	RHTX12-BS	0012320	ETX12-BS	YTX12-BS
	Trophy	1200	00-04	RHTX14-BS	0012390	ETX14-BS	YTX14-BS
	TT600	600	00-03	RHTX12-BS	0012320	ETX12-BS	YTX12-BS
VICTORY	Cross Country	1731	10-	RHTX20L-BS	0012640		YTX20L-BS
	Crossroads	1731	12	RHTX20L-BS	0012640		YTX20L-BS
	High Ball	1731	12	RHTX20L-BS	0012640		YTX20L-BS
YAMAHA	Vegas Jackpot, Hammer, Ness, Vision	1731	08-10	RHTX20L-BS	0012640		YTX20L-BS
	Aerox	100	-	RHTX4L-BS	0012310	ETX4L-BS	YTX4L-BS
	AG200FE	200	-	RHTZ75-BS	0012500		YTZ75-BS
	AL115, C	115	-	RHB5L-B	0012240	EB5L-B	YB5L-B
	Bolt, Bolt R-SPEC	950	14-	RHTZ14S-BS	0012580		YTZ14S-BS
	BT Bulldog	1100	02-06	RHT14B-BS			
	Burgman	660	-	RHTX14-BS	0012390	ETX14-BS	YTX14-BS
	BW's 100	90	99	RHTX5L-BS	0012380	ETX5L-BS	YTX5L-BS
	BW's 100	100	99	RHTX5L-BS	0012380	ETX5L-BS	YTX5L-BS
	CE50 RIVA JOG	50	86-87	RHB4L-B	0012180	EB4L-B	YB4L-B
	CE50D	50	-	RHTX5L-BS	0012380	ETX5L-BS	YTX5L-BS
	CE50S Riva	50	86-87	RHB4L-B	0012180	EB4L-B	YB4L-B
	CG50	50	88-91	RHB4L-B	0012180	EB4L-B	YB4L-B
	CP250, V	250	05-	RHTZ10S-BS	0012540		YTZ10S-BS
	CR50, Z	50	89-95	RHB4L-B	0012180	EB4L-B	YB4L-B
	CR90	90	91	RHB4L-B	0012180	EB4L-B	YB4L-B
	CS50, Z	50	05	RHTX4L-BS	0012310	ETX4L-BS	YTX4L-BS
	CT	50	90-95	RHB4L-B	0012180	EB4L-B	YB4L-B
	CV50, ZR	50	84	RHTX4L-BS	0012310	ETX4L-BS	YTX4L-BS
	CV50A, R, ZR	50	04	RHTX4L-BS	0012310	ETX4L-BS	YTX4L-BS
	CW50 Zuma	50	89-90	RHB4L-B	0012180	EB4L-B	YB4L-B
	CW50 Zuma II	50	97-01	RHB4L-B	0012180	EB4L-B	YB4L-B
	CW50, N, RS, RSP	50	09-	RHB4L-B	0012180	EB4L-B	YB4L-B
	CW50, RS, RSX, BW's	50	91-97	RHB4L-B	0012180	EB4L-B	YB4L-B
	CW50RSP NG	50	96-97	RHB4L-B	0012180	EB4L-B	YB4L-B
	CW65	65	94	RHB4L-B	0012180	EB4L-B	YB4L-B
	CX50L, LN, N, RS, RSP	50	04-09	RHB4L-B	0012180	EB4L-B	YB4L-B
	CY50 Riva Jog	50	92-01	RHTX4L-BS	0012310	ETX4L-BS	YTX4L-BS
	CY50, B, D, E, G, R, Z	50	89-95	RHTX4L-BS	0012310	ETX4L-BS	YTX4L-BS
	DS6B, DS6C	250	69-70	RHB5L-B	0012240	EB5L-B	YB5L-B
	DT	50	03-08	RHB4L-B	0012180	EB4L-B	YB4L-B
	EW Slider	50	00-02	RHB4L-B	0012180	EB4L-B	YB4L-B
	EW50	50	05	RHB4L-B	0012180	EB4L-B	YB4L-B
	EW50N	50	05-	RHB4L-B	0012180	EB4L-B	YB4L-B

BATTERIE MOTO - ATV, UTV - MARINE

MARCA MAKE	MODELLO MODEL	CC CC	ANNO YEAR	BATTERIA RHIAG RHIAG BATTERY	BATTERIA MPT MOTORPARTS BATTERY	BATTERIA EXIDE EXIDE BATTERY	BATTERIA YUASA YUASA BATTERY
YAMAHA	FJ1200, A	1200	91-93	RHTX14-BS	0012390	ETX14-BS	YTX14-BS
	FJR1300	1300	03-10	RHT14B-BS			
	FJR1300, A, AP, AS, ASY, AW, AWCS, SC	1300	01-	RHT14B-BS			
	FTZ6 Fazer	600	04-05	RHT12B-BS	0012550	ET12B-BS	YT12B-BS
	FZ-09	850	14-	RHTZ10S-BS	0012540		YTZ10S-BS
	FZ1	1000	06-08	RHTZ14S-BS	0012580		YTZ14S-BS
	FZ1 Fazer	1000	06-08	RHTZ14S-BS	0012580		YTZ14S-BS
	FZ1-N, S, SA	1000	06-	RHTZ14S-BS	0012580		YTZ14S-BS
	FZ6 Fazer	600	04-08	RHT12B-BS	0012550	ET12B-BS	YT12B-BS
	FZ6, NS, S2	600	04-08	RHT12B-BS	0012550	ET12B-BS	YT12B-BS
	FZ6, R	600	05-10	RHT12B-BS	0012550	ET12B-BS	YT12B-BS
	FZ8 Fazer	779	10-	RHTZ10S-BS	0012540		YTZ10S-BS
	FZ8, R	800	10-	RHTZ10S-BS	0012540		YTZ10S-BS
	FZR1000	1000	91-95	RHTX14-BS	0012390	ETX14-BS	YTX14-BS
	FZR1000 Exup	1000	92-95	RHTX14-BS	0012390	ETX14-BS	YTX14-BS
	FZR1000, FZR1000F	1000	91-95	RHTX14-BS	0012390	ETX14-BS	YTX14-BS
	FZR400RR, RRSP	400	92-	RHTX9-BS	0012330	ETX9-BS	YTX9-BS
	FZR600	600	89-90	RHB12AL-A	0012340	EB12AL-A	YB12AL-A
	FZR600R	600	94-95	RHTX12-BS	0012320	ETX12-BS	YTX12-BS
	FZR750	750	91-	RHTX9-BS	0012330	ETX9-BS	YTX9-BS
	FZS Fazer	1000	01-05	RHT14B-BS			
	FZS1000 FZ1	1000	01-06	RHT14B-BS			
	FZS1000 FZ1	1000	06-10	RHTZ10S-BS	0012540		YTZ10S-BS
	FZS1000, S, T, FZ1	1000	01-05	RHT14B-BS			
	FZS6	600	04	RHT12B-BS	0012550	ET12B-BS	YT12B-BS
	FZS600 Fazer	600	99	RHT12B-BS	0012550	ET12B-BS	YT12B-BS
	FZS600S Fazer	600	00-	RHT12B-BS	0012550	ET12B-BS	YT12B-BS
	GTS1000, A	1000	93-94	RHTX14-BS	0012390	ETX14-BS	YTX14-BS
	JOG ZR	50	11-	RHTX5L-BS	0012380	ETX5L-BS	YTX5L-BS
	KJR400R	400	04-	RHTX9-BS	0012330	ETX9-BS	YTX9-BS
	MAXAM	250	10-	RHTZ10S-BS	0012540		YTZ10S-BS
	MORPHOUS	250	06-07	RHTZ10S-BS	0012540		YTZ10S-BS
	MT-01, S	1700	02-08	RHT14B-BS			
	MT-03	660	06-10	RHT9B-BS	0012530	ET9B-BS	YT9B-BS
	MT09, ABS	850	14-	RHTZ10S-BS	0012540		YTZ10S-BS
	NEO'S	50	98	RHB4L-B	0012180	EB4L-B	YB4L-B
	Neo's	100	-	RHTX4L-BS	0012310	ETX4L-BS	YTX4L-BS
	NXC Cygnus X	125	06	RHTX7A-BS	0012350	ETX7A-BS	YTX7A-BS
	NXC Cygnus X	125	04-05	RHTX7L-BS	0012430	ETX7L-BS	YTX7L-BS
	NXC Cygnus X	125	07-08	RHT7B-BS	0012520	ET7B-BS	YT7B-BS
NXC125	125	04-	RHTX7A-BS	0012350	ETX7A-BS	YTX7A-BS	
Original	50	-	RHB4L-B	0012180	EB4L-B	YB4L-B	
R3	350	69	RHB5L-B	0012240	EB5L-B	YB5L-B	
RD125LC	125	82	RHB5L-B	0012240	EB5L-B	YB5L-B	
RD200, DX	200	75-79	RHB9-B		EB9-B	YB9-B	
RD350LC-FH, FN, H, N	350	86-90	RHB5L-B	0012240	EB5L-B	YB5L-B	
S1000	1000	93-94	RHTX14-BS	0012390	ETX14-BS	YTX14-BS	
SH50 Riva Razz	50	87-01	RHB4L-B	0012180	EB4L-B	YB4L-B	
SH50, E, D, M Riva	50	87-94	RHB4L-B	0012180	EB4L-B	YB4L-B	
Slider	50	00-	RHB4L-B	0012180	EB4L-B	YB4L-B	
SP500 T-MAX	500	09-10	RHTZ10S-BS	0012540		YTZ10S-BS	

MARCA MAKE	MODELLO MODEL	CC CC	ANNO YEAR	BATTERIA RHIAG RHIAG BATTERY	BATTERIA MPT MOTORPARTS BATTERY	BATTERIA EXIDE EXIDE BATTERY	BATTERIA YUASA YUASA BATTERY
YAMAHA	Spy	50	-	RHB4L-B	0012180	EB4L-B	YB4L-B
	SRV250, G	250	93-	RHTX7A-BS	0012350	ETX7A-BS	YTX7A-BS
	SRX600	600	10-	RHT12B-BS	0012550	ET12B-BS	YT12B-BS
	SRX600, H, N	600	86-90	RHB5L-B	0012240	EB5L-B	YB5L-B
	STS/SS	50	-	RHB4L-B	0012180	EB4L-B	YB4L-B
	SZR660	660	96-	RHTX9-BS	0012330	ETX9-BS	YTX9-BS
	T-MAX	500	00-	RHT9B-BS	0012530	ET9B-BS	YT9B-BS
	T110S, SE, SEC, LSE	110	-	RHB5L-B	0012240	EB5L-B	YB5L-B
	T115LE, LSE	115	09-	RHB5L-B	0012240	EB5L-B	YB5L-B
	T90D, N	90	-	RHTX4L-BS	0012310	ETX4L-BS	YTX4L-BS
	TDM 02	900	-	RHT12B-BS	0012550	ET12B-BS	YT12B-BS
	TDM850	850	92-93	RHTX12-BS	0012320	ETX12-BS	YTX12-BS
	TDM850, N	850	91-	RHT12B-BS	0012550	ET12B-BS	YT12B-BS
	TDM900	900	10-	RHTX12-BS	0012320	ETX12-BS	YTX12-BS
	TDM900 (EU)	900	10	RHT12B-BS	0012550	ET12B-BS	YT12B-BS
	TDM900, A	900	04-	RHT12B-BS	0012550	ET12B-BS	YT12B-BS
	TDR125, R	125	93-	RHTX5L-BS	0012380	ETX5L-BS	YTX5L-BS
	TDR250	250	88-90	RHB5L-B	0012240	EB5L-B	YB5L-B
	TQ100	100	01	RHTX4L-BS	0012310	ETX4L-BS	YTX4L-BS
	TRICKER	250	10-	RHTZ7S-BS	0012500		YTZ7S-BS
	TRX850	850	95-99	RHTX12-BS	0012320	ETX12-BS	YTX12-BS
	TT250	250	99-03	RHT7B-BS	0012520	ET7B-BS	YT7B-BS
	TT600RE	600	04	RHT9B-BS	0012530	ET9B-BS	YT9B-BS
	TT600S	600	93	RHTX4L-BS	0012310	ETX4L-BS	YTX4L-BS
	TTR125/LE Electric Start	125	03-07	RHTX4L-BS	0012310	ETX4L-BS	YTX4L-BS
	TTR125E, -S, LE, LES, LWE	125	03-07	RHTX4L-BS	0012310	ETX4L-BS	YTX4L-BS
	TTR225	225	99-05	RHT7B-BS	0012520	ET7B-BS	YT7B-BS
	TTR230, T, V	230	05-	RHTX5L-BS	0012380	ETX5L-BS	YTX5L-BS
	TTR230E	230	06-07	RHTZ7S-BS/RHTX5L-BS	0012380	ETX5L-BS	YTX5L-BS
	TTR250, V	250	99-06	RHT7B-BS	0012520	ET7B-BS	YT7B-BS
	TX750	750	73-74	RHTX20L-BS	0012640		YTX20L-BS
	TZR125, R	125	-	RHB5L-B	0012240	EB5L-B	YB5L-B
	TZR250	250	88-90	RHB5L-B	0012240	EB5L-B	YB5L-B
	TZR50	50	03-08	RHTX4L-BS	0012310	ETX4L-BS	YTX4L-BS
	TZR80, D	80	91-	RHTX4L-BS	0012310	ETX4L-BS	YTX4L-BS
	V-Star_XV51100	1100	99-10	RHT14B-BS			
	V100E	100	93-94	RHB5L-B	0012240	EB5L-B	YB5L-B
	V110, E	110	93-95	RHB5L-B	0012240	EB5L-B	YB5L-B
	Vity	125	08	RHTX7A-BS	0012350	ETX7A-BS	YTX7A-BS
	VMAX	1700	09-10	RHTZ14S-BS	0012580		YTZ14S-BS
	VMX12 F, V-MAX	1200	85-07	RHB16AL-A2			
	VOX	50	10	RHTZ7S-BS/RHTX5L-BS	0012380	ETX5L-BS	YTX5L-BS
	VOX	50	11-	RHTX5L-BS	0012380	ETX5L-BS	YTX5L-BS
	VP X City	250	07-08	RHTX9-BS	0012330	ETX9-BS	YTX9-BS
	VP X-City	125	08	RHTX9-BS	0012330	ETX9-BS	YTX9-BS
VP125, R	125	09-	RHTX9-BS	0012330	ETX9-BS	YTX9-BS	
VP250	250	07-	RHTX9-BS	0012330	ETX9-BS	YTX9-BS	
VP300	300	04-	RHTX9-BS	0012330	ETX9-BS	YTX9-BS	
Why	50	99	RHB4L-B	0012180	EB4L-B	YB4L-B	
WR F, R, X	250	08	RHTZ7S-BS	0012500		YTZ7S-BS	
WR250F	250	03-07	RHTX5L-BS/RHTZ7S-BS	0012380	ETX5L-BS	YTX5L-BS	

BATTERIE MOTO - ATV, UTV - MARINE

MARCA	MODELLO	CC	ANNO	BATTERIA RHIAG	BATTERIA MPT	BATTERIA EXIDE	BATTERIA YUASA
MAKE	MODEL	CC	YEAR	RHIAG BATTERY	MOTORPARTS BATTERY	EXIDE BATTERY	YUASA BATTERY
YAMAHA	WR250FR	250	07	RHTZ75-BS	0012500		YTZ75-BS
	WR250R, RY, RYC, X, XY, XYC	250	09-	RHTZ75-BS	0012500		YTZ75-BS
	WR450F	450	03	RHTX5L-BS	0012380	ETX5L-BS	YTX5L-BS
	WR450F, S	450	03-08	RHTZ75-BS	0012500		YTZ75-BS
	WY600SD SECA II	600	92-94	RHTX9-BS	0012330	ETX9-BS	YTX9-BS
	XC Fly One	150	97-98	RHTX7L-BS	0012430	ETX7L-BS	YTX7L-BS
	XC Versity	300	03-06	RHTX9-BS	0012330	ETX9-BS	YTX9-BS
	XC100	100	07	RHT7B-BS/RHTX5L-BS	0012520/0012380	ET7B-BS/ETX5L-BS	YT7B-BS/YTX5L-BS
	XC125 Cygus-X	125	04-	RHTX7A-BS	0012350	ETX7A-BS	YTX7A-BS
	XC125, CR	125	07-09	RHT7B-BS	0012520	ET7B-BS	YT7B-BS
	XC125E	125	-	RHTX7A-BS	0012350	ETX7A-BS	YTX7A-BS
	XC125R, T, TR Cygnus	125	93-	RHTX7A-BS	0012350	ETX7A-BS	YTX7A-BS
	XC125TRB	125	07	RHTX7A-BS	0012350	ETX7A-BS	YTX7A-BS
	XC180, D, Z Riva	180	83-85	RHB10L-B-P	0012480	EB10L-B	YB10L-B
	XC50 VINO CLASSIC	50	06-10	RHTZ75-BS/RHTX5L-BS	0012380	ETX5L-BS	YTX5L-BS
	XC50, D	50	04	RHTX5L-BS	0012380	ETX5L-BS	YTX5L-BS
	Xenter 125	125	12	RHT7B-BS	0012520	ET7B-BS	YT7B-BS
	XF-Giggle	50	08	RHTX5L-BS	0012380	ETX5L-BS	YTX5L-BS
	XF50	50	07-09	RHTX5L-BS	0012380	ETX5L-BS	YTX5L-BS
	XF50W (C3)	50	07-10	RHTZ75-BS/RHTX5L-BS	0012380	ETX5L-BS	YTX5L-BS
	XG250	250	04-	RHTZ75-BS	0012500		YTZ75-BS
	XJ6 (ABS)	600	12	RHT12B-BS	0012550	ET12B-BS	YT12B-BS
	XJ6 Diversion, F	600	12	RHT12B-BS	0012550	ET12B-BS	YT12B-BS
	XJ6 Diversion, F	600	10-	RHT12B-BS	0012550	ET12B-BS	YT12B-BS
	XJ600N	600	94-	RHTX9-BS	0012330	ETX9-BS	YTX9-BS
	XJ600S	600	09-	RHT12B-BS	0012550	ET12B-BS	YT12B-BS
	XJ600S Diversion	600	92-	RHTX9-BS	0012330	ETX9-BS	YTX9-BS
	XJ600S SECA II	600	92-98	RHTX9-BS	0012330	ETX9-BS	YTX9-BS
	XJ6N, NA, S, SA, SY	600	09-	RHT12B-BS	0012550	ET12B-BS	YT12B-BS
	XJ900P	900	-	RHTX14-BS	0012390	ETX14-BS	YTX14-BS
	XJ900S Diversion	900	95-	RHTX14-BS	0012390	ETX14-BS	YTX14-BS
	XJ900S Diversion	900	95-02	RHTX14-BS	0012390	ETX14-BS	YTX14-BS
	XJR	1300	07-10	RHTZ14S-BS	0012580		YTZ14S-BS
	XJR1200, SP	1200	95-	RHTX14-BS	0012390	ETX14-BS	YTX14-BS
	XJR1300, SP	1300	99-06	RHT14B-BS			
	XJR1300, Y	1300	07-	RHTZ14S-BS	0012580		YTZ14S-BS
	XPT-Max	500	08	RHTZ10S-BS	0012540		YTZ10S-BS
	XPT-Max	500	01-07	RHT9B-BS	0012530	ET9B-BS	YT9B-BS
	XP500, A, Y	500	08-09	RHTZ10S-BS	0012540		YTZ10S-BS
	XT	600	84-89	RHB5L-B	0012240	EB5L-B	YB5L-B
	XT R	125	05-08	RHTX7L-BS	0012430	ETX7L-BS	YTX7L-BS
	XT X	125	05-08	RHTX7L-BS	0012430	ETX7L-BS	YTX7L-BS
XT1200Z Super Tenere	1200	10-	RHTZ12S-BS		ELTZ14S	YTZ12-S	
XT225	225	01-07	RHTZ75-BS	0012500		YTZ75-BS	
XT225 Serow	225	92-00	RHTX7L-BS	0012430	ETX7L-BS	YTX7L-BS	
XT225, E, EC, F, FG, G, GC	225	93-	RHTX7L-BS	0012430	ETX7L-BS	YTX7L-BS	
XT225, V	225	01-03	RHTZ75-BS	0012500		YTZ75-BS	
XT250	250	08-10	RHTZ75-BS	0012500		YTZ75-BS	
XT250V	250	06	RHTX7L-BS	0012430	ETX7L-BS	YTX7L-BS	
XT500E	500	93-	RHTX9-BS	0012330	ETX9-BS	YTX9-BS	
XT550	550	82-83	RHB5L-B	0012240	EB5L-B	YB5L-B	

MARCA	MODELLO	CC	ANNO	BATTERIA RHIAG	BATTERIA MPT	BATTERIA EXIDE	BATTERIA YUASA
MAKE	MODEL	CC	YEAR	RHIAG BATTERY	MOTORPARTS BATTERY	EXIDE BATTERY	YUASA BATTERY
YAMAHA	XT600E, EH, EN	600	90-02	RHTX9-BS	0012330	ETX9-BS	YTX9-BS
	XT600E, EH, EN, H, N, Z	600	83-85	RHB5L-B	0012240	EB5L-B	YB5L-B
	XT600E, F, G	600	90-95	RHTX9-BS	0012330	ETX9-BS	YTX9-BS
	XT600KH	600	91-93	RHTX4L-BS	0012310	ETX4L-BS	YTX4L-BS
	XT600KH	600	94-95	RHTX4L-BS	0012310	ETX4L-BS	YTX4L-BS
	XT600X	660	04-10	RHT9B-BS	0012530	ET9B-BS	YT9B-BS
	XT660Z (EU)	660	04-10	RHT9B-BS	0012530	ET9B-BS	YT9B-BS
	XTZ125E, K	125	-	RHB5L-B	0012240	EB5L-B	YB5L-B
	XTZ250	250	07-	RHTX7L-BS	0012430	ETX7L-BS	YTX7L-BS
	XTZ660 Tenere	660	08	RHT9B-BS	0012530	ET9B-BS	YT9B-BS
	XTZ660 Tenere	660	92-96	RHTX9-BS	0012330	ETX9-BS	YTX9-BS
	XV A Midnight Star	1900	06-08	RHT14B-BS			
	XV1600, Road Star	1600	99-06	RHTX20L-BS	0012640		YTX20L-BS
	XV1600A Wild Star	1600	00-	RHTX20L-BS	0012640		YTX20L-BS
	XV1700 Road Star Warrior	1700	02-06	RHT14B-BS			
	XV1700ATMV, AV, AVC	1700	-	RHTX20L-BS	0012640		YTX20L-BS
	XV1700PC, CMV	1700	02-	RHT14B-BS			
	XV17AT Road Star, Silverado	1700	04-07	RHTX20L-BS	0012640		YTX20L-BS
	XV17AT Road Star, Silverado	1700	08-10	RHT14B-BS			
	XV1900, A, CT	1900	07-	RHT14B-BS			
	XV19CSY, CSYC, CY, CYC	1854	09-	RHT14B-BS			
	XV19SV, SVC, CTSV	1900	06	RHT14B-BS			
	XV400	400	95	RHB12AL-A	0012340	EB12AL-A	YB12AL-A
	XV700 Virago	700	84-87	RHB16AL-A2			
	XV700C	700	84-87	RHB16AL-A2			
	XV700S	700	84-86	RHB16AL-A2			
	XV750, MIDNIGHT VIRAGO	750	81-96	RHB16AL-A2			
	XV750SE, Virago	750	81-	RHB16AL-A2			
	XVF600RT, C	650	05	RHTX12-BS	0012320	ETX12-BS	YTX12-BS
	XVS 1300A Midnight	1300	11-	RHTX20L-BS	0012640		YTX20L-BS
	XVS 1900A Midnight	1900	11	RHT14B-BS			
	XVS A Mdnight Star	1300	07-08	RHTX20L-BS	0012640		YTX20L-BS
	XVS1100 Drag Star	1100	99	RHT14B-BS			
	XVS1100 V-Star	1100	99-10	RHT14B-BS			
	XVS1100A Drag Star	1100	00-	RHT14B-BS			
	XVS1100A, W, WC	1100	01-	RHT14B-BS			
	XVS125	125	01-04	RHTZ75-BS	0012500		YTZ75-BS
	XVS1300, AY	1300	07-	RHTX20L-BS	0012640		YTX20L-BS
	XVS13AY V STAR 1300	1300	09-10	RHTX20L-BS	0012640		YTX20L-BS
	XVS250, S	250	04-	RHTZ75-BS	0012500		YTZ75-BS
	XVS400, C	400	04	RHT12B-BS	0012550	ET12B-BS	YT12B-BS
	XVS650 Drag Star	650	97-06	RHT12B-BS	0012550	ET12B-BS	YT12B-BS
	XVS650 V-STAR	650	98-09	RHT12B-BS	0012550	ET12B-BS	YT12B-BS
	XVS650, W, WC	650	97-	RHT12B-BS	0012550	ET12B-BS	YT12B-BS
	XVS650A Drag Star Cla.	650	00-	RHT12B-BS	0012550	ET12B-BS	YT12B-BS
	XVS650V, VC	650	-	RHT12B-BS	0012550	ET12B-BS	YT12B-BS
	XVS950A	950	09-	RHTZ145-BS	0012580		YTZ145-BS
XVS95CT, Y V STAR 950	950	09-10	RHTZ145-BS	0012580		YTZ145-BS	
XVZ13 Royal Star/Venture (All)	1300	96-07	RHTX20L-BS	0012640		YTX20L-BS	
XVZ1300 AT Tour Classic	1300	99	RHTX20L-BS	0012640		YTX20L-BS	
XVZ1300A Royal Star	1300	96-10	RHTX20L-BS	0012640		YTX20L-BS	

BATTERIE MOTO - ATV, UTV - MARINE

MARCA	MODELLO	CC	ANNO	BATTERIA RHIAG	BATTERIA MPT	BATTERIA EXIDE	BATTERIA YUASA
MAKE	MODEL	CC	YEAR	RHIAG BATTERY	MOTORPARTS BATTERY	EXIDE BATTERY	YUASA BATTERY
YAMAHA	XVZ1300TF Royal Star	1300	00-	RHTX20L-BS	0012640		YTX20L-BS
	XVZ13CT, CTS	1300	09-	RHTX20L-BS	0012640		YTX20L-BS
	YA ZA Jog Z	50	95-96	RHB4L-B	0012180	EB4L-B	YB4L-B
	YA50R Axis	50	96-	RHTX4L-BS	0012310	ETX4L-BS	YTX4L-BS
	YA50T	50	93	RHTX4L-BS	0012310	ETX4L-BS	YTX4L-BS
	YA6	125	64-66	RHB10L-B-P	0012480	EB10L-B	YB10L-B
	YA90	90	93-	RHTX4L-BS	0012310	ETX4L-BS	YTX4L-BS
	YB125E, C, CE	125	-	RHB5L-B	0012240	EB5L-B	YB5L-B
	YB50	50	98	RHTX4L-BS	0012310	ETX4L-BS	YTX4L-BS
	YBR	250	07	RHTX7L-BS	0012430	ETX7L-BS	YTX7L-BS
	YBR 125 Custom	125	11-	RHTX7L-BS	0012430	ETX7L-BS	YTX7L-BS
	YBR110A	110	-	RHB5L-B	0012240	EB5L-B	YB5L-B
	YBR125DX	125	09-	RHB5L-B	0012240	EB5L-B	YB5L-B
	YBR125ED	125	07-09	RHTX7L-BS	0012430	ETX7L-BS	YTX7L-BS
	YBR125EG, EGD	125	05	RHB5L-B	0012240	EB5L-B	YB5L-B
	YE50 Zest	50	93-97	RHTX4L-BS	0012310	ETX4L-BS	YTX4L-BS
	YE80 Zesyt	80	94-96	RHB4L-B	0012180	EB4L-B	YB4L-B
	YH50	50	09-	RHB4L-B	0012180	EB4L-B	YB4L-B
	YJ125T VINO 125	125	04-10	RHTX7A-BS	0012350	ETX7A-BS	YTX7A-BS
	YL50	50	-	RHTX4L-BS	0012310	ETX4L-BS	YTX4L-BS
	YM50 Breeze	50	95-96	RHB4L-B	0012180	EB4L-B	YB4L-B
	YN Neo's	50	07-08	RHB4L-B	0012180	EB4L-B	YB4L-B
	YN Neo's	100	-	RHTX4L-BS	0012310	ETX4L-BS	YTX4L-BS
	YN50, M	50	09-	RHB4L-B	0012180	EB4L-B	YB4L-B
	YP MAJESTY	400	03-10	RHT9B-BS	0012530	ET9B-BS	YT9B-BS
	YP R X-Max	125	06-08	RHTX9-BS	0012330	ETX9-BS	YTX9-BS
	YP R X-Max	250	05-08	RHTX9-BS	0012330	ETX9-BS	YTX9-BS
	YP125, E	125	09-	RHB7L-B2/RHTX9-BS	0012420/0012330	ETX9-BS	YB7L-B2/YTX9-BS
	YP250	250	07-	RHTZ10S-BS	0012540		YTZ10S-BS
	YP250 DX/ABS Majesty	250	96-	RHT7B-BS	0012520	ET7B-BS	YT7B-BS
	YP250 Majesty	250	00-	RHT7B-BS	0012520	ET7B-BS	YT7B-BS
	YP250, L, C, G	250	04-	RHT9B-BS	0012530	ET9B-BS	YT9B-BS
	YP250, YP250R, YP250RA	250	07-	RHTX9-BS	0012330	ETX9-BS	YTX9-BS
	YP250R	250	-	RHTX9-BS	0012330	ETX9-BS	YTX9-BS
	YP250RA	250	-	RHTX9-BS	0012330	ETX9-BS	YTX9-BS
	YPR X-MAX, ABS	125	14-	RHT9B-BS	0012530	ET9B-BS	YT9B-BS
	YPR125R Majesty	125	99-	RHB7L-B2/RHTX9-BS	0012420/0012330	ETX9-BS	YB7L-B2/YTX9-BS
	YQ50, L	50	05-	RHB4L-B	0012180	EB4L-B	YB4L-B
	YS250	250	07-	RHTX7L-BS	0012430	ETX7L-BS	YTX7L-BS
	YT100 (Taiwan)	100	99	RHTX5L-BS	0012380	ETX5L-BS	YTX5L-BS
	YTZF-R1, W, WC	1000	04-	RHTZ10S-BS	0012540		YTZ10S-BS
	YVX11AWY, AWYC, AY	1100	09-	RHT14B-BS			
YW125	125	09-	RHT7B-BS	0012520	ET7B-BS	YT7B-BS	
YW50A Zuma	50	02-04	RHTX5L-BS/RHTZ7S-BS	0012380	ETX5L-BS	YTX5L-BS	
YZ50, D, ZS	50	-	RHTX4L-BS	0012310	ETX4L-BS	YTX4L-BS	
YZF R6	600	06-10	RHTZ10S-BS	0012540		YTZ10S-BS	
YZF R6 Limited Edition	600	07	RHTZ10S-BS	0012540		YTZ10S-BS	
YZF-R1	1000	99-03	RHT12B-BS	0012550	ET12B-BS	YT12B-BS	
YZF-R1 LEV	1000	06	RHTZ10S-BS	0012540		YTZ10S-BS	
YZF-R1, Y, YC	1000	04-10	RHTZ10S-BS	0012540		YTZ10S-BS	
YZF-R1S	1000	06	RHTZ10S-BS	0012540		YTZ10S-BS	

MARCA	MODELLO	CC	ANNO	BATTERIA RHIAG	BATTERIA MPT	BATTERIA EXIDE	BATTERIA YUASA
MAKE	MODEL	CC	YEAR	RHIAG BATTERY	MOTORPARTS BATTERY	EXIDE BATTERY	YUASA BATTERY
YAMAHA	YZF-R6	600	99-00	RHT12B-BS	0012550	ET12B-BS	YT12B-BS
	YZF-R6, R6S	600	01-05	RHT9B-BS	0012530	ET9B-BS	YT9B-BS
	YZF-R6, S, SC, SV	600	01-05	RHT9B-BS	0012530	ET9B-BS	YT9B-BS
	YZF-R6, W, EC	600	06-09	RHTZ10S-BS	0012540		YTZ10S-BS
	YZF-R7, owo2	750	99	RHT9B-BS	0012530	ET9B-BS	YT9B-BS
	YZF1000R Thunderace	1000	96-	RHTX14-BS	0012390	ETX14-BS	YTX14-BS
	YZF1000R, RJ	1000	97-98	RHTX14-BS	0012390	ETX14-BS	YTX14-BS
	YZF600FGC, RG, RW	600	95	RHTX12-BS	0012320	ETX12-BS	YTX12-BS
	YZF600R Thunder Cat	600	96-03	RHTX12-BS	0012320	ETX12-BS	YTX12-BS
	YZF600R, RH, RJ, RK	600	95-07	RHTX12-BS	0012320	ETX12-BS	YTX12-BS
	YZF750R, SP, RF, RJ, RH, RK	750	93-98	RHTX12-BS	0012320	ETX12-BS	YTX12-BS
	Zuma	50	-	RHB4L-B	0012180	EB4L-B	YB4L-B
Zuma 125	125	09-10	RHTX7A-BS	0012350	ETX7A-BS	YTX7A-BS	
BATTERIE ATV - UTV							
AEON (BENZA)	Cobra/CX-Sport	50	All	RHTX4L-BS	0012310	ETX4L-BS	YTX4L-BS
	Cobra/CX-Sport	90	All	RHTX4L-BS	0012310	ETX4L-BS	YTX4L-BS
	Cobra/CX-Sport	100	All	RHTX4L-BS	0012310	ETX4L-BS	YTX4L-BS
ARCTIC CAT	150	150	10	RHTX9-BS	0012330	ETX9-BS	YTX9-BS
	250	250	10	RHTX12-BS	0012320	ETX12-BS	YTX12-BS
	All Models	90	02	RHTX4L-BS	0012310	ETX4L-BS	YTX4L-BS
	DVX250, 2X4	250	06	RHTX12-BS	0012320	ETX12-BS	YTX12-BS
	DVX300	300	10	RHTX12-BS	0012320	ETX12-BS	YTX12-BS
	DVX400	400	All	RHTX9-BS	0012330	ETX9-BS	YTX9-BS
	DVX50	50	06-10	RHTX5L-BS/RHTZ75-BS	0012380	ETX5L-BS	YTX5L-BS
	DVX90	90	06-10	RHTX5L-BS/RHTZ75-BS	0012380	ETX5L-BS	YTX5L-BS
	Prowler 1000	1000	10	RHB30L-B			YB30L-B
	BOMBARDIER	Commander	800	11-	RHTX20L-BS	0012640	
Commander		1000	11-	RHTX20L-BS	0012640		YTX20L-BS
DS250		250	06-10	RHTX12-BS	0012320	ETX12-BS	YTX12-BS
DS450		450	09-10	RHT7B-BS	0012520	ET7B-BS	YT7B-BS
DS50, Quest		50	02-06	RHTX4L-BS	0012310	ETX4L-BS	YTX4L-BS
DS70		70	10	RHTX4L-BS	0012310	ETX4L-BS	YTX4L-BS
DS90, DS90F, Quest		90	02-10	RHTX4L-BS	0012310	ETX4L-BS	YTX4L-BS
Outlander 660 EFI		660	06	RHTX20L-BS	0012640		YTX20L-BS
Outlander 800 EFI		800	06-10	RHTX20L-BS	0012640		YTX20L-BS
Outlander, Max		650	10	RHTX20L-BS	0012640		YTX20L-BS
Outlander, Max, Renegade		500	09-10	RHTX20L-BS	0012640		YTX20L-BS
Outlander, Renegade		1000	12-	RHTX20L-BS	0012640		YTX20L-BS
Outlander400XT,MAX		400	04-10	RHTX20L-BS	0012640		YTX20L-BS
BRP-SKI-DOO	Grand Touring, Renegade	550	-12	RHTX20L-BS	0012640		YTX20L-BS
	ZX		02-03	RHTX20L-BS	0012640		YTX20L-BS
CANNONDALE	All Models	60	01-03	RHTX9-BS	0012330	ETX9-BS	YTX9-BS
	Blaze, Cannibal, Moto	440	02-03	RHTX9-BS	0012330	ETX9-BS	YTX9-BS
	FX400	400	01	RHTX9-BS	0012330	ETX9-BS	YTX9-BS
	Glamis, Speed	440	02-03	RHTX9-BS	0012330	ETX9-BS	YTX9-BS
HM	All Models	50	04-05	RHTX5L-BS/RHTZ75-BS	0012380	ETX5L-BS	YTX5L-BS
	All Models	90	04-10	RHTX5L-BS/RHTZ75-BS	0012380	ETX5L-BS	YTX5L-BS
	AXL, TXL, NXL, RXL	50	99-03	RHTX4L-BS	0012310	ETX4L-BS	YTX4L-BS
	AXL, TXL, NXL, RXL	90	99-03	RHTX4L-BS	0012310	ETX4L-BS	YTX4L-BS
	CXL150 Yukon II	150	00-01	RHTX9-BS	0012330	ETX9-BS	YTX9-BS
	DXL90 Sierra	90	99-03	RHTX5L-BS	0012380	ETX5L-BS	YTX5L-BS

BATTERIE MOTO - ATV, UTV - MARINE

MARCA	MODELLO	CC	ANNO	BATTERIA RHIAG	BATTERIA MPT	BATTERIA EXIDE	BATTERIA YUASA
MAKE	MODEL	CC	YEAR	RHIAG BATTERY	MOTORPARTS BATTERY	EXIDE BATTERY	YUASA BATTERY
HM	TRX EX Sportrax 5-6-7	400	05-07	RHTX9-BS	0012330	ETX9-BS	YTX9-BS
	TRX FA Fourtrax Rincon 5 (CAN)	650	05	RHTX14-BS	0012390	ETX14-BS	YTX14-BS
	TRX FA Fourtrax Rincon 5 (EUR,AUS)	650	05	RHTX20L-BS	0012640		YTX20L-BS
	TRX FA Fourtrax Rincon 6-7	680	07	RHTX20L-BS	0012640		YTX20L-BS
	TRX FA Rancher 4-6	400	04-06	RHTX14-BS	0012390	ETX14-BS	YTX14-BS
	TRX R 5-7 TRX ER 6-7 Sportrax	450	05-07	RHTZ75-BS	0012500		YTZ75-BS
	TRX TE Fourtrax Rincon 6-7	250	06-07	RHTX12-BS	0012320	ETX12-BS	YTX12-BS
	Vector 250	250	10	RHTX12-BS	0012320	ETX12-BS	YTX12-BS
	Viper 150R	150	10	RHTX9-BS	0012330	ETX9-BS	YTX9-BS
	Viper 70	70	10	RHTZ75-BS/RHTX5L-BS	0012380	ETX5L-BS	YTX5L-BS
HONDA	YXL150 Yukon	150	02-03	RHTX9-BS	0012330	ETX9-BS	YTX9-BS
	ATC125M	125	86-87	RHTX12-BS	0012320	ETX12-BS	YTX12-BS
	ATC250EC Big Red	250	85-87	RHTX12-BS	0012320	ETX12-BS	YTX12-BS
	ATC250SX	250	85-87	RHTX12-BS	0012320	ETX12-BS	YTX12-BS
	FL350R Odissey	350	85	RHTX12-BS	0012320	ETX12-BS	YTX12-BS
	FL400R Pilot	400	89-90	RHTX14-BS	0012390	ETX14-BS	YTX14-BS
	Foreman, TRX500 S/ES Foreman	500	98-09	RHTX14-BS	0012390	ETX14-BS	YTX14-BS
	Four 300EX	300	96	RHTX14-BS	0012390	ETX14-BS	YTX14-BS
	FourTrax Foreman ES, 4X4	500	05-09	RHTX14-BS	0012390	ETX14-BS	YTX14-BS
	MUV700 Big Red	700	08-10	RHTX14-BS	0012390	ETX14-BS	YTX14-BS
	TR250TE, TM, FourTraxRecon	250	97-11	RHTX12-BS	0012320	ETX12-BS	YTX12-BS
	TRX125 Fourtrax	125	87-88	RHTX9-BS	0012330	ETX9-BS	YTX9-BS
	TRX200 Fourtrax	200	90-97	RHTX12-BS	0012320	ETX12-BS	YTX12-BS
	TRX200D Fourtrax Type II	200	91-96	RHTX12-BS	0012320	ETX12-BS	YTX12-BS
	TRX200SX Fourtrax	200	86-88	RHTX12-BS	0012320	ETX12-BS	YTX12-BS
	TRX250 EX, Sportrax	250	01-03	RHTX9-BS	0012330	ETX9-BS	YTX9-BS
	TRX250 EX, TE, TM	250	01-12	RHTX9-BS	0012330	ETX9-BS	YTX9-BS
	TRX250 Fourtrax	250	85-87	RHTX12-BS	0012320	ETX12-BS	YTX12-BS
	TRX250 Recon, ES	250	97-07	RHTX12-BS	0012320	ETX12-BS	YTX12-BS
	TRX250TE, TM FourTrax Recon ES	250	97-10	RHTX12-BS	0012320	ETX12-BS	YTX12-BS
	TRX250X, EX Sportrax	250	01-10	RHTX9-BS	0012330	ETX9-BS	YTX9-BS
	TRX300 Fourtrax	300	88-02	RHTX14-BS	0012390	ETX14-BS	YTX14-BS
	TRX300EX Fourtrax	300	88-00	RHTX9-BS	0012330	ETX9-BS	YTX9-BS
	TRX300EX Fourtrax 4X4	300	88-00	RHTX14-BS	0012390	ETX14-BS	YTX14-BS
	TRX300FW Fourtrax 300 4X4	300	88-00	RHTX12-BS	0012320	ETX12-BS	YTX12-BS
	TRX300X, EX	300	93-12	RHTX9-BS	0012330	ETX9-BS	YTX9-BS
	TRX350 Fourtrax	350	86-87	RHTX14-BS	0012390	ETX14-BS	YTX14-BS
	TRX350 Fourtrax 4X4	350	86-89	RHTX14-BS	0012390	ETX14-BS	YTX14-BS
	TRX350 Rancher	350	00-06	RHTX14-BS	0012390	ETX14-BS	YTX14-BS
	TRX350D Rancher	350	00-	RHTX14-BS	0012390	ETX14-BS	YTX14-BS
	TRX400 Rancher AT	400	04-07	RHTX14-BS	0012390	ETX14-BS	YTX14-BS
	TRX400EX, FourTrax, Sportrax	400	99-10	RHTX9-BS	0012330	ETX9-BS	YTX9-BS
	TRX400FE, FM, TM	400	05-06	RHTX14-BS	0012390	ETX14-BS	YTX14-BS
	TRX400FW Foreman	400	95-06	RHTX14-BS	0012390	ETX14-BS	YTX14-BS
	TRX420 Fourtrax Rancher 4X4	420	09	RHTX14-BS	0012390	ETX14-BS	YTX14-BS
	TRX450ER	450	06-09	RHTZ75-BS	0012500		YTZ75-BS
TRX450R	450	06-08	RHTZ75-BS	0012500		YTZ75-BS	
TRX450S Fourtrax S.ES	450	98-04	RHTX14-BS	0012390	ETX14-BS	YTX14-BS	
TRX450S Fourtrax Rubicon	450	01-03	RHTX14-BS	0012390	ETX14-BS	YTX14-BS	
TRX500 Fourtrax Rubicon	500	01-10	RHTX14-BS	0012390	ETX14-BS	YTX14-BS	
TRX500FE, FM, TM Four Trax	500	05-10	RHTX14-BS	0012390	ETX14-BS	YTX14-BS	

MARCA	MODELLO	CC	ANNO	BATTERIA RHIAG	BATTERIA MPT	BATTERIA EXIDE	BATTERIA YUASA
MAKE	MODEL	CC	YEAR	RHIAG BATTERY	MOTORPARTS BATTERY	EXIDE BATTERY	YUASA BATTERY
HONDA	TRX650 Fourtrax Rincon	650	03-05	RHTX14-BS	0012390	ETX14-BS	YTX14-BS
	TRX650A (Optionl cold starting)	650	03-05	RHTX20L-BS	0012640		YTX20L-BS
	TRX680 Fourtrax Rincon	680	06-10	RHTX20L-BS	0012640		YTX20L-BS
	TRX700XX	700	08-10	RHTX9-BS	0012330	ETX9-BS	YTX9-BS
	TRX90	90	06	RHTX5L-BS	0012380	ETX5L-BS	YTX5L-BS
HYOSUNG	TRX900X, EX	90	06-10	RHTZ7S-BS/RHTX5L-BS	0012380	ETX5L-BS	YTX5L-BS
	TE	50	05	RHTX5L-BS	0012380	ETX5L-BS	YTX5L-BS
	TE	90	05	RHTX5L-BS	0012380	ETX5L-BS	YTX5L-BS
	TE	450	07	RHTX9-BS	0012330	ETX9-BS	YTX9-BS
KASEA	TE450S	450	10	RHTX9-BS	0012330	ETX9-BS	YTX9-BS
	KS, KU Models	65	All	RHTX7A-BS	0012350	ETX7A-BS	YTX7A-BS
KAWASAKI	KS, KU Models	90	All	RHTX7A-BS	0012350	ETX7A-BS	YTX7A-BS
	KS, KU Models, Adventure buggy	125	All	RHTX7A-BS	0012350	ETX7A-BS	YTX7A-BS
	Mini Skyhawk	50	All	RHTX4L-BS	0012310	ETX4L-BS	YTX4L-BS
	Skyhawk150, Adventure Buggy	150	All	RHTX7A-BS	0012350	ETX7A-BS	YTX7A-BS
	Skyhawk170	170	All	RHTX7A-BS	0012350	ETX7A-BS	YTX7A-BS
	Skyhawk250	250	All	RHTX7A-BS	0012350	ETX7A-BS	YTX7A-BS
	Skyhawk50	50	All	RHTX5L-BS/RHTZ7S-BS	0012380	ETX5L-BS	YTX5L-BS
	Skyhawk90	90	All	RHTX5L-BS/RHTZ7S-BS	0012380	ETX5L-BS	YTX5L-BS
	4X4 Advantage Classic	650	04-06	RHTX14-BS	0012390	ETX14-BS	YTX14-BS
	FKLF185-A Bayou	185	85-88	RHB10L-B-P	0012480	EB10L-B	YB10L-B
	JH 1200-A,B Ultra 150	1200	99-05	RHTX20L-BS	0012640		YTX20L-BS
	JH1100 ZXi	1100	96-03	RHTX20L-BS	0012640		YTX20L-BS
	JH1100-B Ultra 130	1100	01-04	RHTX20L-BS	0012640		YTX20L-BS
	JT1100-A1 STX	1100	97-03	RHTX20L-BS	0012640		YTX20L-BS
	JT1200-A-B,C, STX-R,STX-12F	1200	02-07	RHTX20L-BS	0012640		YTX20L-BS
	JT1500-A STX-15F	1500	04-10	RHTX20L-BS	0012640		YTX20L-BS
	JT1500B,C,250X,Ultra LX	1500	07-10	RHTX20L-BS	0012640		YTX20L-BS
KAF400, Mule 600, 610	400	05-12	RHTX14-BS	0012390	ETX14-BS	YTX14-BS	
KAF620, Mule 3000, 3010, 3020	620	03-07	RHTX20L-BS	0012640		YTX20L-BS	
KAF620, Mule 3010 4*4, Advantage Classic	620	03-07	RHTX20L-BS	0012640		YTX20L-BS	
KAF650F, Mule 4010 4*4 (CN)	620	10	RHTX20L-BS	0012640		YTX20L-BS	
KFX R B8F	450	08-12	RHTX7L-BS	0012430	ETX7L-BS	YTX7L-BS	
KFX50	50	07-10	RHTZ7S-BS/RHTX5L-BS	0012380	ETX5L-BS	YTX5L-BS	
KFX700 V-Force	700	05-10	RHTX14-BS	0012390	ETX14-BS	YTX14-BS	
KFX90	90	07-10	RHTZ7S-BS/RHTX5L-BS	0012380	ETX5L-BS	YTX5L-BS	
KLT200-A. C	200	81-84	RHB10L-B-P	0012480	EB10L-B	YB10L-B	
KLT250-C Prairie	250	84-85	RHB10L-B-P	0012480	EB10L-B	YB10L-B	
KSF400-A (KFX400)	400	03-06	RHTX9-BS	0012330	ETX9-BS	YTX9-BS	
KSF80-A(KFX80)	80	03-05	RHTX5L-BS/RHTZ7S-BS	0012380	ETX5L-BS	YTX5L-BS	
KSV700A, B, D Prairie 700, 4X4	700	04-08	RHTX14-BS	0012390	ETX14-BS	YTX14-BS	
KVF 4X4 Brute Force	650	06-08	RHTX14-BS	0012390	ETX14-BS	YTX14-BS	
KVF400-C, -D Prairie (CN)	400	99-00	RHTX14-BS	0012390	ETX14-BS	YTX14-BS	
KVF650A, B, D Prairie 650	650	04-06	RHTX14-BS	0012390	ETX14-BS	YTX14-BS	
KVF700A, B, D Prairie 700, 4X4	700	04-06	RHTX14-BS	0012390	ETX14-BS	YTX14-BS	
KVF750A, B Brute Force750 4X4	750	05-10	RHTX14-BS	0012390	ETX14-BS	YTX14-BS	
Teryx (CN)	750	08-10	RHTX14-BS	0012390	ETX14-BS	YTX14-BS	
KTM	SX ATV	450	08-10	RHTZ7S-BS/RHTX5L-BS	0012380	ETX5L-BS	YTX5L-BS
	SX ATV	505	08-10	RHTZ7S-BS/RHTX5L-BS	0012380	ETX5L-BS	YTX5L-BS
	SX ATV	525	10	RHTZ7S-BS/RHTX5L-BS	0012380	ETX5L-BS	YTX5L-BS
	XC ATV	450	08-09	RHTZ7S-BS/RHTX5L-BS	0012380	ETX5L-BS	YTX5L-BS

BATTERIE MOTO
ATV/UTV/MARINE

BATTERIE MOTO - ATV, UTV - MARINE

MARCA MAKE	MODELLO MODEL	CC CC	ANNO YEAR	BATTERIA RHIAG RHIAG BATTERY	BATTERIA MPT MOTORPARTS BATTERY	BATTERIA EXIDE EXIDE BATTERY	BATTERIA YUASA YUASA BATTERY	
KTM KYMCO	XC ATV	505	08-09	RHTZ75-BS/RHTX5L-BS	0012380	ETX5L-BS	YTX5L-BS	
	KXR	50	04	RHTX5L-BS	0012380	ETX5L-BS	YTX5L-BS	
	MAXXER	50	05	RHTX5L-BS	0012380	ETX5L-BS	YTX5L-BS	
	MAXXER	300	05-06	RHTX12-BS	0012320	ETX12-BS	YTX12-BS	
	MAXXER 400	400	11-	RHTX20L-BS	0012640		YTX20L-BS	
	MAXXER 450	450	-	RHTX20L-BS	0012640		YTX20L-BS	
	MAXXER 500	350	11-	RHTX14-BS	0012390	ETX14-BS	YTX14-BS	
	MAXXER 90	90	-	RHTX5L-BS	0012380	ETX5L-BS	YTX5L-BS	
	Mongoose 300	300	10	RHTX12-BS	0012320	ETX12-BS	YTX12-BS	
	Mongoose 50	50	All	RHTZ75-BS/RHTX5L-BS	0012380	ETX5L-BS	YTX5L-BS	
	Mongoose 90	90	All	RHTZ75-BS/RHTX5L-BS	0012380	ETX5L-BS	YTX5L-BS	
	Mongoose, MXU250	250	All	RHTX12-BS	0012320	ETX12-BS	YTX12-BS	
	MXER	50	02-03	RHTX5L-BS	0012380	ETX5L-BS	YTX5L-BS	
	MXER	125	02-03	RHTX9-BS	0012330	ETX9-BS	YTX9-BS	
	MXER	150	04	RHTX9-BS	0012330	ETX9-BS	YTX9-BS	
	MXU	150	05-06	RHTX9-BS	0012330	ETX9-BS	YTX9-BS	
	MXU	300	05-06	RHTX12-BS	0012320	ETX12-BS	YTX12-BS	
	MXU	500	05-06	RHTX20L-BS	0012640		YTX20L-BS	
	MXU	500	10-	RHTX20L-BS	0012640		YTX20L-BS	
	MXU 400	400	11-	RHTX12-BS	0012320	ETX12-BS	YTX12-BS	
	MXU 450i	400	-	RHTX20L-BS	0012640		YTX20L-BS	
	MXU SR	50	06-07	RHTX9-BS	0012330	ETX9-BS	YTX9-BS	
	MXU300SD	300	All	RHTX12-BS	0012320	ETX12-BS	YTX12-BS	
	UXV 500	500	11-	RHTX20L-BS	0012640		YTX20L-BS	
	UXV 500	500	11-	RHTX20L-BS	0012640		YTX20L-BS	
	UXV500	500	10	RHTX20L-BS	0012640		YTX20L-BS	
	LAVERDA	Qusar 125-150	125	02-04	RHTX9-BS	0012330	ETX9-BS	YTX9-BS
		Qusar 50-100	50	02-04	RHTX9-BS	0012330	ETX9-BS	YTX9-BS
	PIAGGIO	Ape 50 FL		89-95	RHB9-B		EB9-B	YB9-B
		Ape 50 FL/FL2		00-	RHB9-B		EB9-B	YB9-B
		Ape 50 FL2		00-	RHB9-B		EB9-B	YB9-B
		Ape 50 FL3		93-99	RHB9-B		EB9-B	YB9-B
Ape 50 FL3 Europa/UN/			00-	RH60-N35L-AHD			53211/6MK5	
Ape P50 / Ape MP, MPR			-	RH60-N30L-AHD	0012730		53030	
Ape RST Mix			99-05	RHB9-B		EB9-B	YB9-B	
APE TM			82-83	RH60-N35L-AHD			53211/6MK5	
Ape TM P703-P703V			84-05	RH60-N35L-AHD			53211/6MK5	
Cross/Ape 50 P			00-	RH60-N35L-AHD			53211/6MK5	
POLARIS	Diesel (primary)	450	99-03	RHB30L-B			YB30L-B	
	FS/FST	750	06-10	RHTX20L-BS	0012640		YTX20L-BS	
	Outlaw 450	450	07-10	RHTX9-BS	0012330	ETX9-BS	YTX9-BS	
	Outlaw 525	525	08-10	RHTX9-BS	0012330	ETX9-BS	YTX9-BS	
	Phoenix, Sawtooth	200	05-10	RHTX12-BS	0012320	ETX12-BS	YTX12-BS	
	Predator, Outlaw	50	04-10	RHTX5L-BS/RHTZ75-BS	0012380	ETX5L-BS	YTX5L-BS	
	Predator, Outlaw	500	03-06	RHTX9-BS	0012330	ETX9-BS	YTX9-BS	
	Predator, Sportsman, Outlaw	90	03-10	RHTX5L-BS/RHTZ75-BS	0012380	ETX5L-BS	YTX5L-BS	
	Ranger 2x4	425	02-03	RHB30L-B			YB30L-B	
	Ranger 6X6	500	98-00	RHB30L-B			YB30L-B	
	Ranger 6x6, 4x4	500	98-11	RHB30L-B			YB30L-B	
	Ranger RZR	170	-12	RHTX12-BS	0012320	ETX12-BS	YTX12-BS	
Ranger RZR	170	10	RHTX12-BS	0012320	ETX12-BS	YTX12-BS		

MARCA MAKE	MODELLO MODEL	CC CC	ANNO YEAR	BATTERIA RHIAG RHIAG BATTERY	BATTERIA MPT MOTORPARTS BATTERY	BATTERIA EXIDE EXIDE BATTERY	BATTERIA YUASA YUASA BATTERY
POLARIS	Ranger RZR	170	14-	RHTX12-BS	0012320	ETX12-BS	YTX12-BS
	Ruch, RMK, Pro, Assault, SWBK	800	12	RHTX20L-BS	0012640		YTX20L-BS
	Rush RMK Pro Assault SWBK	800	12-	RHTX20L-BS	0012640		YTX20L-BS
	Scrambler	50	03	RHTX5L-BS/RHTZ7S-BS	0012380	ETX5L-BS	YTX5L-BS
	Scrambler	50	01-02	RHTX4L-BS	0012310	ETX4L-BS	YTX4L-BS
	Scrambler	850	14-	RHTX20L-BS	0012640		YTX20L-BS
	Scrambler	1000	14-	RHTX20L-BS	0012640		YTX20L-BS
	Scrambler, Sportsman	90	01-02	RHTX4L-BS	0012310	ETX4L-BS	YTX4L-BS
	Sportman	600	04-05	RHB30L-B			YB30L-B
	Sportman, Military	700	02-08	RHB30L-B			YB30L-B
	Sportsman	550	10	RHB30L-B			YB30L-B
	Sportsman	800	14-	RHTX20L-BS	0012640		YTX20L-BS
	Turbo LX	750	10	RHTX20L-BS	0012640		YTX20L-BS
	Turbo Switchback, Turbo Dragon	750	06-10	RHTX20L-BS	0012640		YTX20L-BS
	QIANJIANG	ATV100	100	-	RHTX4L-BS	0012310	ETX4L-BS
ATV50		50	-	RHTX4L-BS	0012310	ETX4L-BS	YTX4L-BS
SUZUKI	LT-A Kingquad	400	10	RHTX14-BS	0012390	ETX14-BS	YTX14-BS
	LT-A Kingquad	450	07-10	RHTX14-BS	0012390	ETX14-BS	YTX14-BS
	LT-A400 Eiger 2WD, F Eiger 4WD	400	02-07	RHTX14-BS	0012390	ETX14-BS	YTX14-BS
	LT-F Kingquad FS	400	08	RHTX14-BS	0012390	ETX14-BS	YTX14-BS
	LT-F250, F Qzark	250	02-10	RHTX12-BS	0012320	ETX12-BS	YTX12-BS
	LT-F400 Eiger 2WD, F Eiger 4WD	400	02-07	RHTX14-BS	0012390	ETX14-BS	YTX14-BS
	LT-R Quad racer	450	06-10	RHTX7A-BS/RHTZ10S-BS	0012350	ETX7A-BS	YTX7A-BS
	LT-V700F Twin Peaks	700	04-05	RHTX14-BS	0012390	ETX14-BS	YTX14-BS
	LT-Z QuadSport K4-K8	400	03-10	RHTX9-BS	0012330	ETX9-BS	YTX9-BS
	LT-Z250 QuadSport	250	04-10	RHTX12-BS	0012320	ETX12-BS	YTX12-BS
	LT-Z90 QuadSport	90	07-10	RHTX7A-BS	0012350	ETX7A-BS	YTX7A-BS
	LT700 Twin Peaks	700	04-05	RHTX14-BS	0012390	ETX14-BS	YTX14-BS
	LT80 Quad Sport	80	87-06	RHTX5L-BS/RHTZ7S-BS	0012380	ETX5L-BS	YTX5L-BS
	LTZ250 Quad Runner	250	04-05	RHTX12-BS	0012320	ETX12-BS	YTX12-BS
	Quad Sport Z 50	50	06-10	RHTX5L-BS/RHTZ7S-BS	0012380	ETX5L-BS	YTX5L-BS
	QUV F	620	05	RHTX20L-BS	0012640		YTX20L-BS
	QUV F	620	05	RHTX20L-BS	0012640		YTX20L-BS
	SYM	Quad Lender	250	06-07	RHTX12-BS	0012320	ETX12-BS
Quad Lender		300	07-08	RHTX12-BS	0012320	ETX12-BS	YTX12-BS
TGB/WINKING	Track Runner	180	-	RHTX12-BS	0012320	ETX12-BS	YTX12-BS
	50 Akros	50	97	RHTX4L-BS	0012310	ETX4L-BS	YTX4L-BS
	50 Ergon	50	97	RHTX4L-BS	0012310	ETX4L-BS	YTX4L-BS
	AS25 Bunny	50	96	RHB4L-B	0012180	EB4L-B	YB4L-B
	AS50 X Bunny	50	94-95	RHB4L-B	0012180	EB4L-B	YB4L-B
	AS50 X Kurier	50	95	RHB4L-B	0012180	EB4L-B	YB4L-B
	AT50 Bunny	50	93	RHB4L-B	0012180	EB4L-B	YB4L-B
	AT50 Bunny Gespann	50	93-94	RHB4L-B	0012180	EB4L-B	YB4L-B
	Tutti i modelli / All models	50	00	RHB4L-B	0012180	EB4L-B	YB4L-B
	Tutti i modelli / All models	90	00	RHB4L-B	0012180	EB4L-B	YB4L-B
	Tutti i modelli / All models	125	00	RHB4L-B	0012180	EB4L-B	YB4L-B
	Tutti i modelli / All models	150	00	RHB4L-B	0012180	EB4L-B	YB4L-B
YAMAHA	Apex	998	06-10	RHTX14-BS	0012390	ETX14-BS	YTX14-BS
	CF300	300	83-96	RHB16AL-A2			
	EX570	570	88-96	RHB16AL-A2			
	FX Nytro	1049	09-10	RHTX20L-BS	0012640		YTX20L-BS

BATTERIE MOTO - ATV, UTV - MARINE

MARCA MAKE	MODELLO MODEL	CC CC	ANNO YEAR	BATTERIA RHIAG RHIAG BATTERY	BATTERIA MPT MOTORPARTS BATTERY	BATTERIA EXIDE EXIDE BATTERY	BATTERIA YUASA YUASA BATTERY
YAMAHA	Phazer	499	09	RHTX14-BS	0012390	ETX14-BS	YTX14-BS
	Phazer	500	10	RHTX14-BS	0012390	ETX14-BS	YTX14-BS
	PZ50, GT, MP, MT, RT, VT	500	09-	RHTX14-BS	0012390	ETX14-BS	YTX14-BS
	PZ500DX Phazer500 Deluxe	500	01	RHTX14-BS	0012390	ETX14-BS	YTX14-BS
	Raptor	350	04-05	RHTZ10S-BS	0012540		YTZ10S-BS
	RS Vector	1049	10	RHTX20L-BS	0012640		YTX20L-BS
	RS Venture	1049	10	RHTX20L-BS	0012640		YTX20L-BS
	RS Viking Professional	1049	09-10	RHTX20L-BS	0012640		YTX20L-BS
	RS1000S, GT, RS	1000	06-10	RHTX20L-BS	0012640		YTX20L-BS
	RS90GT, LTGT	973	09-	RHTX20L-BS	0012640		YTX20L-BS
	RX10 LTGT, MT, MTR, RTR	1000	09-	RHTX14-BS	0012390	ETX14-BS	YTX14-BS
	RX1000R RX (All Models)	1000	03-05	RHTX20L-BS	0012640		YTX20L-BS
	RX10GT	1000	09-	RHTX14-BS	0012390	ETX14-BS	YTX14-BS
	V-max 500	500	94-99	RHB16AL-A2			
	V-max 600DX, ST	600	94-97	RHB16AL-A2			
	Vector	973	09	RHTX20L-BS	0012640		YTX20L-BS
	Venture Lite	499	09	RHTX14-BS	0012390	ETX14-BS	YTX14-BS
	Venture Lite	500	10	RHTX14-BS	0012390	ETX14-BS	YTX14-BS
	Viking	973	09	RHTX20L-BS	0012640		YTX20L-BS
	VK1000	1000	-	RHTX20L-BS	0012640		YTX20L-BS
	VK1000	1000	-	RHTX20L-BS	0012640		YTX20L-BS
	VK540E, II, III	540	89-03	RHB16AL-A2			
	VT500 Venture	500	97-01	RHB16AL-A2			
	VT500 Venture 500XL	500	99-00	RHB16AL-A2			
	VT600 Venture	600	97-98	RHB16AL-A2			
	VX500 Ovation	500	96-97	RHB16AL-A2			
	VX500E Vmax	500	94-01	RHB16AL-A2			
	VX600 Ovation	600	96-97	RHB16AL-A2			
	VX600E/DX Vmax 600 LE/DX	600	94-96	RHB16AL-A2			
	VX60XTC Vmax 600 XTC	600	97-98	RHB16AL-A2			
	VX700 Ovation	700	96	RHB16AL-A2			
	XL540	540	85-96	RHB16AL-A2			
	YF40FG Grizzly	400	07-08	RHTX20L-BS	0012640		YTX20L-BS
	YFM	250	08	RHTZ7S-BS	0012500		YTZ7S-BS
	YFM 350RV Raptor	350	04-05	RHTZ10S-BS	0012540		YTZ10S-BS
	YFM 35RX	350	08	RHTZ10S-BS	0012540		YTZ10S-BS
	YFM 7GPW Grizzly	700	07-10	RHTX20L-BS	0012640		YTX20L-BS
	YFM AS Bruin, FAS, FGW, FGX, GW	350	04-07	RHTX14-BS	0012390	ETX14-BS	YTX14-BS
	YFM FS Grizzly	660	04	RHTX20L-BS	0012640		YTX20L-BS
	YFM RW	700	07	RHT9B-BS	0012530	ET9B-BS	YT9B-BS
	YFM S	350	08	RHTZ10S-BS	0012540		YTZ10S-BS
	YFM12R Raptor	125	11-	RHTZ7S-BS	0012500		YTZ7S-BS
	YFM250R Raptor	250	08-10	RHTZ7S-BS	0012500		YTZ7S-BS
	YFM25RY, RSEY	250	09-	RHTZ7S-BS	0012500		YTZ7S-BS
YFM350R Raptor	350	07-10	RHTZ10S-BS	0012540		YTZ10S-BS	
YFM400FM Kodiak	400	96-08	RHTX20L-BS	0012640		YTX20L-BS	
YFM400FW Kodiak	400	02	RHTX20L-BS	0012640		YTX20L-BS	
YFM400FWFN Big Bear	400	00-03	RHTX20L-BS	0012640		YTX20L-BS	
YFM400N Big Bear	400	00-03	RHTX20L-BS	0012640		YTX20L-BS	
YFM40FB Big Bear	400	00-10	RHTX20L-BS	0012640		YTX20L-BS	

MARCA	MODELLO	CC	ANNO	BATTERIA RHIAG	BATTERIA MPT	BATTERIA EXIDE	BATTERIA YUASA
MAKE	MODEL	CC	YEAR	RHIAG BATTERY	MOTORPARTS BATTERY	EXIDE BATTERY	YUASA BATTERY
YAMAHA	YFM40FW Kodiak/Automatic	400	96-02	RHTX20L-BS	0012640		YTX20L-BS
	YFM40FW Kodiak/Automatic	400	96-02	RHTX20L-BS	0012640		YTX20L-BS
	YFM40N Big Bear 2WD	400	00-03	RHTX20L-BS	0012640		YTX20L-BS
	YFM450FW Kodiak/Automatic	450	03-	RHTX20L-BS	0012640		YTX20L-BS
	YFM45FW Automatic	450	03-09	RHTX20L-BS	0012640		YTX20L-BS
	YFM550G, GY	550	09-	RHTX20L-BS	0012640		YTX20L-BS
	YFM5FGPY, GPSEY	550	09-	RHTX20L-BS	0012640		YTX20L-BS
	YFM600FW Grizzly	600	02-03	RHTX20L-BS	0012640		YTX20L-BS
	YFM660FA Grizzly	660	02-08	RHTX20L-BS	0012640		YTX20L-BS
	YFM660R Rapter	660	01-06	RHTX14-BS	0012390	ETX14-BS	YTX14-BS
	YFM700 Raptor	700	06-10	RHT9B-BS	0012530	ET9B-BS	YT9B-BS
	YFM700FWAD	700	07	RHTX20L-BS	0012640		YTX20L-BS
	YFM70RY	700	09-	RHT9B-BS	0012530	ET9B-BS	YT9B-BS
	YFM7FG Grizzly	700	07-12	RHTX20L-BS	0012640		YTX20L-BS
	YFM90R Raptor	90	09-10	RHTZ7S-BS/RHTX5L-BS	0012380	ETX5L-BS	YTX5L-BS
	YFV600FW Grizzly	600	98-01	RHTX20L-BS	0012640		YTX20L-BS
	YFZ S	450	04	RHT7B-BS	0012520	ET7B-BS	YT7B-BS
	YFZ450,SEW,V	450	04-09	RHT7B-BS	0012520	ET7B-BS	YT7B-BS
	YFZ450R	450	09-10	RHTZ7S-BS	0012500		YTZ7S-BS
	YFZ450V	450	-09	RHTX20L-BS	0012640		YTX20L-BS
	YFZ450X	450	08	RHT7B-BS	0012520	ET7B-BS	YT7B-BS
	YMF FAS, FGW Grizzly	450	02-10	RHTX20L-BS	0012640		YTX20L-BS
	YMF FPS Big Bear Profesional	400	04	RHTX20L-BS	0012640		YTX20L-BS
	YMF FXW, FXX Wolverine	450	07-10	RHTX20L-BS	0012640		YTX20L-BS
	YMF RR, RS	660	03-04	RHTX14-BS	0012390	ETX14-BS	YTX14-BS
	YMF XW	350	07	RHTX14-BS	0012390	ETX14-BS	YTX14-BS
	YMF5FG Grizzly	550	10	RHTX20L-BS	0012640		YTX20L-BS
	YZF450R, RSEY	450	09-12	RHTZ7S-BS	0012500		YTZ7S-BS
YZF450X	450	-12	RHT7B-BS	0012520	ET7B-BS	YT7B-BS	
BATTERIE MARINE							
HONDA	Aqua Trax F-12X, F-12	1235	02-09	RHTX20L-BS	0012640		YTX20L-BS
	Aqua Trax R-12X, R-12	1235	02-09	RHTX20L-BS	0012640		YTX20L-BS
KAWASAKI	AquaTrax F-15, F-15X	1470	03-10	RHTX20L-BS	0012640		YTX20L-BS
	JH750 C1-C3(Zxi)	750	95-97	RHTX20L-BS	0012640		YTX20L-BS
	JH750 E1(X-4)	750	95-99	RHTX20L-BS	0012640		YTX20L-BS
	JH750 F2(Xi-II)	750	95-99	RHTX20L-BS	0012640		YTX20L-BS
	JH750 G1/G2	750	95-99	RHTX20L-BS	0012640		YTX20L-BS
	JH750 ST,Zxi	750	95-97	RHTX20L-BS	0012640		YTX20L-BS
	JH900 A1/A2 (Zxi)	900	95-97	RHTX20L-BS	0012640		YTX20L-BS
	JS400-A Jet Ski	400	76	RHTX20L-BS	0012640		YTX20L-BS
	JS440-A Jet Ski	440	77-86	RHTX20L-BS	0012640		YTX20L-BS
	JS550	550	82-85	RHTX20L-BS	0012640		YTX20L-BS
	JS750 SXi,SXi Pro	750	95-02	RHTX20L-BS	0012640		YTX20L-BS
	JS800 SX-R	800	03-10	RHTX20L-BS	0012640		YTX20L-BS
	JS900 ZXi	900	95-97	RHTX20L-BS	0012640		YTX20L-BS
	JT750 STS,STX	750	96-98	RHTX20L-BS	0012640		YTX20L-BS
	JT900 B1(STX)	900	99	RHTX20L-BS	0012640		YTX20L-BS
	JT900 STX,STS	900	97-05	RHTX20L-BS	0012640		YTX20L-BS
JT900A2	900	98	RHTX20L-BS	0012640		YTX20L-BS	





***FILTRI HIFLO
ATV - UTV***

FILTRI HIFLO ATV - UTV

MARCA MAKE	MODELLO MODEL	CC CC	ANNO YEAR	OLIO OIL	RICAMBIO FILTRO DI SERIE REPLAC. FOR OE FILTER	DISPONIBILE VER- SIONE SPECIALE SPECIAL TYPE AVAILABLE	ARIA AIR	RICAMBIO FILTRO DI SERIE REPLAC. FOR OE FILTER
ACCESS	450 SP S	450		HF303	•	RC		
	450 SP SM Supermoto	450		HF303	•	RC		
	450 SP Sport	450		HF303	•	RC		
	450 Warrior	450		HF303	•	RC		
	700 AX	450		HF303	•	RC		
ADLY	220 S Sentinel	220	07-	HF185	•			
	300 Crossover / Crossroad / Sport / II / RS	300		HF112	•			
	300 S Interceptor / II / Sentinel	300		HF112	•			
	300 Utility	300		HF112	•			
	300 XS Hurricane / Assault	300		HF112	•			
AEON	500 Flat LOF	500		HF112	•			
	500 S Hurrincance	500		HF112	•			
	200 Quad	200	02-08	HF197	•			
	350 Cobra / S	350		HF197	•			
	350 Crossland 2 x 4 / 4 x 4	350		HF197	•			
APACHE	350 Cube 4 x 4	350		HF197	•			
	450 RLX SPORT	450		HF303	•	RC		
ARCTIC CAT	500 RLX 4x4 Landowner	500		HF682	•			
	1000 4x4 Automatic MUD PRO H2 EFI	1000	10-11	HF621	•			
ARCTIC CAT	1000 Alterra TRV 1000 XT	700	17	HF621	•			
	1000 MUD PRO LTD.	1000	13-17	HF621	•			
	1000 MUD PRO LTD. EPS	1000	15	HF621	•			
	1000 MUD PRO LTD. EPS SE	1000	16	HF621	•			
	1000 S H2 EFI	1000	11	HF621	•			
	1000 Thundercat H2	1000	08-10	HF621	•			
	1000 Thundercat H2 LE	1000	10	HF621	•			
	1000 Wildcat LTD / X / XX / 4X	1000	13-18	HF621	•			
	1000 XT	1000	13-17	HF621	•			
	1000 XT EPS	1000	15-17	HF621	•			
	1000i GT	1000	12	HF621	•			
	250 Arctic Cat	250	99-05	HF132	•			
	300 Arctic Cat	300	98-05	HF132	•			
	350 CR	350	11-12	HF621	•			
	366 4x4 Automatic / FIS	366	08-09	HF621	•			
	366 SE	366	10-11	HF621	•			
	400 2x4 Automatic	400	03-04	HF138	•	RC		
	400 4x4	400	04-07	HF138	•	RC		
	400 4x4 ACT	400	04	HF138	•	RC		
	400 4x4 ACT Auto	400	04	HF138	•	RC		
	400 4x4 Automatic	400	03-08	HF138	•	RC		
	400 4x4 Automatic LE	400	05-07	HF138	•	RC		
	400 4x4 Automatic TBX	400	04-06	HF138	•	RC		
	400 4x4 Automatic TRV	400	06-07	HF138	•	RC		
	400 4x4 Automatic VP	400	05-06	HF138	•	RC		
	400 4x4 VP	400	05-06	HF138	•	RC		
	400 Alterra	400	16-17	HF621	•			
400 Arctic Cat	400	98-03	HF138	•	RC			
400 ATV CR / International	400	03-15	HF621	•				
400 Core	400	13						
400 DVX	400	04-08	HF139	•		HFF3022	•	

MARCA MAKE	MODELLO MODEL	CC CC	ANNO YEAR	OLIO OIL	RICAMBIO FILTRO DI SERIE REPLAC. FOR OE FILTER	DISPONIBILE VER- SIONE SPECIALE SPECIAL TYPE AVAILABLE	ARIA AIR	RICAMBIO FILTRO DI SERIE REPLAC. FOR OE FILTER
ARCTIC CAT	400 DVX TS	400	06-07	HF139	•		HFF3022	
	400 TRV Core	400	13	HF621	•			
	400 TRV H1	400	09-10	HF621	•			
	425 CR EFI / SE	425	11-12	HF621	•			
	450 Alterra	450	16	HF621	•			
	450 ATV EFT / International	450	15-16	HF621	•			
	450 Core	450	13	HF621	•			
	450 EFI	450	11	HF621	•			
	450 H1 EFI	450	10	HF621	•			
	450 LTD	450	11	HF621	•			
	450i	450	12	HF621	•			
	454 Arctic Cat	454	96-98	HF138	•	RC		
	500 4x4	500	09	HF621	•			
	500 4x4	500	04-08	HF138	•	RC		
	500 4x4 Automatic	500	04-07	HF138	•	RC		
	500 4x4 Automatic	500	08-09	HF621	•			
	500 4x4 Automatic LE	500	05-06	HF138	•	RC		
	500 4x4 Automatic M4	500	08	HF621	•			
	500 4x4 Automatic TBX	500	04-06	HF138	•	RC		
	500 4x4 Automatic TRV	500	08	HF621	•			
	500 4x4 Automatic TRV	500	04-06	HF138	•	RC		
	500 Alterra	500	17-18	HF621	•			
	500 Alterra XT EPS	500	16	HF621	•			
	500 Arctic Cat	500	98-04	HF138	•	RC		
	500 ATV Red / Green	500	15-16	HF621	•			
	500 Core	500	13-14	HF621	•			
	500 Core EFI	500	13	HF621	•			
	500 HDX XT	500	17	HF621	•			
	500 XR Red / Green	500	15	HF621	•			
	500 XT	500	13	HF621	•			
	550 Alterra TRV XT EPS	550	17	HF621	•			
	550 Core	550	13-14	HF621	•			
	550 H1 EFI Automatic	550	11	HF621	•			
	550 H1 EFI Automatic	550	09-10	HF621	•			
	550 H1 EFI LE	550	09-10	HF621	•			
	550 LTD	550	13-14	HF621	•			
	550 Prowler H1 EFI	550	09	HF621	•			
	550 Prowler HDX	500	15-18	HF621	•			
	550 Prowler XT 4x4	550	10-13	HF621	•			
	550 S H1 EFI Automatic	550	10-11	HF621	•			
	550 S H1 EFI Automatic LTD	550	10-11	HF621	•			
	550 XT	550	13-14	HF621	•			
550i	550	12	HF621	•				
550i GT	550	12	HF621	•				
550i LTD	550	12	HF621	•				
600 4x4	600	04	HF204	•	RC			
600 4x4 LE	600	04	HF204	•	RC			
650 H1 4x4 Automatic	650	07-11	HF621	•				
650 H1 4x4 Automatic FIS	650	07-08	HF621	•				
650 H1 4x4 Automatic LE	650	07	HF621	•				

FILTRI HIFLO ATV - UTV

MARCA MAKE	MODELLO MODEL	CC CC	ANNO YEAR	OLIO OIL	RICAMBIO FILTRO DI SERIE REPLAC. FOR OE FILTER	DISPONIBILE VER- SIONE SPECIALE SPECIAL TYPE AVAILABLE	ARIA AIR	RICAMBIO FILTRO DI SERIE REPLAC. FOR OE FILTER
ARCTIC CAT	650 H1 4x4 Automatic TBX	650	07	HF621	•			
	650 H1 4x4 Automatic TRV Plus	650	07-08	HF621	•			
	650 H1 4x4 SE	650	06-07	HF621	•			
	650 H1 4x4 TRV Plus LE	650	07	HF621	•			
	650 H1 MUD PRO	650	10-11	HF621	•			
	650 Prowler 4x4 Auto	650	08	HF621	•			
	650 Prowler H1	650	07	HF621	•			
	650 Prowler XT 650 H1	650	06-09	HF621	•			
	650 Prowler XT 650 H1 M4	650	08-09	HF621	•			
	650 V-2 4x4	650	06	HF204	•	RC		
	650 V-2 4x4 Automatic	650	04-05	HF204	•	RC		
	650 V-2 4x4 Automatic LE	650	04-05	HF204	•	RC		
	650 V-2 4x4 LE TS	650	06	HF204	•	RC		
	700 4x4 Automatic FIS EFI	700	08	HF621	•			
	700 4x4 Automatic LE EFI	700	07	HF621	•			
	700 4x4 Automatic M4 EFI	700	08	HF621	•			
	700 4x4 Automatic TRV EFI	700	08	HF621	•			
	700 4x4 Automatic TRV LE EFI	700	08	HF621	•			
	700 4x4 Diesel Automatic	700	08-11					
	700 Alterra	700	17-18	HF621	•			
	700 Alterra TBX EPS	700	18	HF621	•			
	700 Alterra TRV XT EPS	700	17	HF621	•			
	700 Alterra VLX Camo	700	18	HF621	•			
	700 Alterra VLX EPS Camo	700	18	HF621	•			
	700 Alterra XT EPS	700	17-18	HF621	•			
	700 Core	700	13-14	HF621	•			
	700 H1 4x4 Automatic EFI	700	07-11	HF621	•			
	700 H1 4x4 Automatic LE EFI	700	09-10	HF621	•			
	700 H1 4x4 Automatic MUD PRO EFI	700	09-11	HF621	•			
	700 HDX Crew XT	700	17	HF621	•			
	700 HDX XT	700	17	HF621	•			
	700 S H1 4x4 Automatic EFI	700	10-11	HF621	•			
	700 S H1 4x4 Automatic LTD EFI	700	10-11	HF621	•			
	700 S H1 4x4 Automatic TBX EFI	700	11	HF621	•			
	700 SE EFI	700	09	HF621	•			
	700 Super Duty Diesel	700	13-15					
	700 TBX EPS	700	17	HF621	•			
	700 Wildcat Sport / International / LTD / Trail / XT / EPS	700	15-18	HF621	•			
	700 XT	700	13-14	HF621	•			
	700i	700	12	HF621	•			
	700i GT	700	12	HF621	•			
	700i LTD	700	12-14	HF621	•			
	700i MudPro	700	12	HF621	•			
	700i MudPro LTD	700	12-17	HF621	•			
	700i MudPro LTD EPS	700	17	HF621	•			
	700i Prowler 4X4 XT	700	17	HF621	•			
	TBX700 EPS	700	15	HF621	•			
TBX700 H1 EFI	700	10	HF621	•				
TBX700 XT Diesel	700	13						
TRV1000 H2 EFI Cruiser	1000	09-10	HF621	•				

MARCA MAKE	MODELLO MODEL	CC CC	ANNO YEAR	OLIO OIL	RICAMBIO FILTRO DI SERIE REPLAC. FOR OE FILTER	DISPONIBILE VER- SIONE SPECIALE SPECIAL TYPE AVAILABLE	ARIA AIR	RICAMBIO FILTRO DI SERIE REPLAC. FOR OE FILTER	
ARCTIC CAT	TRV1000 LTD	1000	13-15	HF621	•				
	TRV1000 LTD EPS	1000	15	HF621	•				
	TRV1000 S H2 EFI Cruiser	1000	11	HF621	•				
	TRV1000 XT EPS	1000	15	HF621	•				
	TRV450	450	11	HF621	•				
	TRV450 EFI	450	11	HF621	•				
	TRV450i	450	12	HF621	•				
	TRV500 Core / International	500	13-15	HF621	•				
	TRV550 H1 EFI	550	11	HF621	•				
	TRV550 H1 EFI	550	09-10	HF621	•				
	TRV550 H1 EFI LE	550	09	HF621	•				
	TRV550 LTD / EPS / XT / International	550	13-15	HF621	•				
	TRV550 S GT	550	10	HF621	•				
	TRV550 S H1 Cruiser EFI	550	11	HF621	•				
	TRV550 S H1 GT EFI	550	11	HF621	•				
	TRV550i Cruiser EFI	550	12	HF621	•				
	TRV550i GT EFI	550	12	HF621	•				
	TRV650 H1	650	09	HF621	•				
	TRV700 H1 EFI	700	10-11	HF621	•				
	TRV700 H1 EFI Cruiser	700	09-11	HF621	•				
	TRV700 LTD EPS	700	13-15	HF621	•				
	TRV700 S GT	700	10	HF621	•				
	TRV700 XT EPS	700	13-15	HF621	•				
	TRV700i GT	700	12	HF621	•				
	XC450 i EFI / EFT / International	450	11-16	HF621	•				
	XR550	550	15	HF621	•				
	XR550 XT EPS	550	15	HF621	•				
	XR700	700	15	HF621	•				
	XR700 XT EPS	700	15	HF621	•				
	XR700 XT EPS Limited	700	15	HF621	•				
	XT1000 Prowler	1000	17	HF621	•				
	XTX700 Prowler 4X4 International Timber Camo	700	10	HF621	•				
	XTX700 Prowler EFI H1	700	09	HF621	•				
	XTX700 Prowler EFI LE	700	09	HF621	•				
	XTX700i Prowler 4X4	700	11-17	HF621	•				
	XTX700i Prowler 4X4 HDX	700	11-16	HF621	•				
	XTZ1000 Prowler	1000	13	HF621	•				
	XTZ1000 Prowler H2 EFI 4x4	1000	09-12	HF621	•				
	BOMBARDIER	650	650	00	HF151	•			
		650	650	01-06	HF152				
200 RALLY		200	03-07	HF559	•				
330 Outlander 330 H.O. 2x4, 4x4		330	04-06	HF152	•				
400 Outlander 400 H.O. 2x4, 4x4		400	04-06	HF152	•				
400 Outlander 400 H.O. 4x4 XT		400	04-06	HF152	•				
400 Outlander Max 400 H.O.		400	04-06	HF152	•				
400 Outlander Max 400 H.O. XT		400	04-06	HF152	•				
500 Quest		500	03-04	HF556	•				
500 Traxter		500	99-05	HF557	•				
500 Traxter Auto CVT		500	05	HF556	•				
500 Traxter Max 5 Speed Auto-Shift		500	03-05	HF557	•				

FILTRI HI FLO
ATV / UTV

FILTRI HIFLO ATV - UTV

MARCA MAKE	MODELLO MODEL	CC CC	ANNO YEAR	OLIO OIL	RICAMBIO FILTRO DI SERIE REPLAC. FOR OE FILTER	DISPONIBILE VER- SIONE SPECIALE SPECIAL TYPE AVAILABLE	ARIA AIR	RICAMBIO FILTRO DI SERIE REPLAC. FOR OE FILTER	
BOMBARDIER	500 Traxter XL 5 Speed	500	99-05	HF557	•				
	500 Traxter XT	500	99-04	HF557	•				
	650 Baja	650	03-04	HF152	•				
	650 Outlander H.O. EFI	650	06	HF152	•				
	650 Outlander H.O. EFI XT	650	06	HF152	•				
	650 Outlander Max H.O. EFI	650	06	HF152	•				
	650 Outlander Max H.O. EFI XT	650	06	HF152	•				
	650 Quest	650	02-04	HF556	•				
	650 Quest Max	650	04	HF556	•				
	650 Quest XT	650	02-03	HF556	•				
	650 Traxter 650 Auto CVT	650	05	HF556	•				
	650 Traxter Max 650 Auto CVT	650	05	HF556	•				
	650 X	650	05-06	HF152	•				
	800 Outlander 800 H.O. EFI	800	06	HF152	•				
	800 Outlander 800 H.O. EFI XT	800	06	HF152	•				
	800 Outlander Max 800 H.O. EFI	800	06	HF152	•				
	800 Outlander Max 800 H.O. EFI XT	800	06	HF152	•				
	CAN-AM	450	450	08	HF560	•			
		450	450	09	HF560	•			
1000 Outlander		1000	12-14	HF152	•				
1000 Outlander 6x6 EFI		1000	15-18	HF152	•				
1000 Outlander 6x6 XT EFI		1000	16-17	HF152	•				
1000 Outlander DPS		1000	13-17	HF152	•				
1000 Outlander EFI		1000	15	HF152	•				
1000 Outlander Max DPS		1000	13-14	HF152	•				
1000 Outlander Max EFI LTD.		1000	15	HF152	•				
1000 Outlander Max LTD.		1000	13-14	HF152	•				
1000 Outlander Max XT		1000	13-14	HF152	•				
1000 Outlander Max XT-P		1000	13-14	HF152	•				
1000 Outlander R DPS		1000	16	HF152	•				
1000 Outlander R EFI		1000	18	HF152	•				
1000 Outlander R Max EFI		1000	15-18	HF152	•				
1000 Outlander R Max LTD		1000	17	HF152	•				
1000 Outlander R Max XT		1000	17	HF152	•				
1000 Outlander R Max XT-P		1000	17	HF152	•				
1000 Outlander R Mossy Oak Huntng Edition		1000	17	HF152	•				
1000 Outlander R X mr EFI		1000	15-18	HF152	•				
1000 Outlander R XT		1000	16-17	HF152	•				
1000 Outlander R XT-P		1000	16-17	HF152	•				
1000 Outlander T3 EFI		1000	18	HF152	•				
1000 Outlander T3 Max EFI		1000	18	HF152	•				
1000 Outlander X mr		1000	13-14	HF152	•				
1000 Outlander X mr EFI		1000	15	HF152	•				
1000 Outlander XT		1000	12-14	HF152	•				
1000 Outlander XT-P		1000	13-14	HF152	•				
1000 Renegade		1000	12-17	HF152	•				
1000 Renegade R EFI		1000	18	HF152	•				
1000 Renegade T3 EFI	1000	18	HF152	•					
1000 Renegade X mr	1000	17	HF152	•					
1000 Renegade X xc	1000	12-17	HF152	•					

MARCA MAKE	MODELLO MODEL	CC CC	ANNO YEAR	OLIO OIL	RICAMBIO FILTRO DI SERIE REPLAC. FOR OE FILTER	DISPONIBILE VER- SIONE SPECIALE SPECIAL TYPE AVAILABLE	ARIA AIR	RICAMBIO FILTRO DI SERIE REPLAC. FOR OE FILTER	
CAN-AM	1000 SSV Commander 4x4	1000	11-15	HF152	•				
	1000 SSV Commander DPS. 4x4	1000	13-17	HF152	•				
	1000 SSV Commander Ltd. 4x4	1000	12-17	HF152	•				
	1000 SSV Commander MAX DPS 4x4	1000	16-17	HF152	•				
	1000 SSV Commander MAX Ltd 4x4	1000	16-17	HF152	•				
	1000 SSV Commander MAX R EFI	1000	18	HF152	•				
	1000 SSV Commander MAX XT 4x4	1000	14-17	HF152	•				
	1000 SSV Commander Mossy Oak Hunter Edition	1000	16-17	HF152	•				
	1000 SSV Commander R EFI 4x4	1000	18	HF152	•				
	1000 SSV Commander X 4x4	1000	11-15	HF152	•				
	1000 SSV Commander XT 4x4	1000	11-17	HF152	•				
	1000 SSV Commander XT-P 4x4	1000	14-16	HF152	•				
	1000 SSV Maverick 1000R	1000	16	HF152	•				
	1000 SSV Maverick 1000R	1000	14-15	HF152	•				
	1000 SSV Maverick 1000R DPS	1000	16-18	HF152	•				
	1000 SSV Maverick 1000R Turbo	1000	17	HF152	•				
	1000 SSV Maverick 1000R xc	1000	17-18	HF152	•				
	1000 SSV Maverick 1000R xc DPS	1000	17-18	HF152	•				
	1000 SSV Maverick MAX DPS 1000R	1000	16-17	HF152	•				
	1000 SSV Maverick MAX Turbo	1000	17	HF152	•				
	1000 SSV Maverick MAX X 1000R	1000	16	HF152	•				
	1000 SSV Maverick MAX X 1000R Turbo	1000	16-17	HF152	•				
	1000 SSV Maverick Max X MR 1000R	1000	17	HF152	•				
	1000 SSV Maverick MAX X RS 1000R	1000	14-15	HF152	•				
	1000 SSV Maverick MAX X RS 1000R Turbo	1000	16-17	HF152	•				
	1000 SSV Maverick Trail EFI	1000	18	HF152	•				
	1000 SSV Maverick X 1000R	1000	16	HF152	•				
	1000 SSV Maverick X 1000R Turbo	1000	16	HF152	•				
	1000 SSV Maverick X MR 1000R	1000	17	HF152	•				
	1000 SSV Maverick X MR DPS 1000R	1000	14-16	HF152	•				
	1000 SSV Maverick X RS 1000R	1000	14-16	HF152	•				
	1000 SSV Maverick X RS 1000R Turbo	1000	16	HF152	•				
	1000 SSV Maverick X RS DPS 1000R	1000	14-15	HF152	•				
	1000 SSV Maverick X XC 1000R	1000	17	HF152	•				
	1000 SSV Maverick X XC DPS 1000R	1000	14-16	HF152	•				
	1330 F3 Spyder SE6	1330	15						
	1330 F3 Spyder SE6 LTD	1330	18						
	1330 F3 Spyder SM6	1330	15						
	1330 F3 STD Spyder SE6	1330	18						
	1330 F3 T Spyder SE6	1330	18						
	1330 F3-S Spyder SE6	1330	15-18						
	1330 F3-S Spyder SM6	1330	15-18						
	1330 RT Spyder SE6	1330	15						
	1330 RT Spyder SE6 LTD.	1330	15-18						
	1330 RT Spyder SM6	1330	15						
1330 RT STD Spyder SE6	1330	18							
1330 RT STD Spyder SM6	1330	18							
1330 RTS Spyder Special Seeries SE6	1330	15							
400 Outlander EFI	400	09-14		HF152	•				
400 Outlander EFI XT	400	09-13		HF152	•				

FILTRI HIFLO ATV - UTV

MARCA MAKE	MODELLO MODEL	CC CC	ANNO YEAR	OLIO OIL	RICAMBIO FILTRO DI SERIE REPLAC. FOR OE FILTER	DISPONIBILE VER- SIONE SPECIALE SPECIAL TYPE AVAILABLE	ARIA AIR	RICAMBIO FILTRO DI SERIE REPLAC. FOR OE FILTER	
CAN-AM	400 Outlander H.O	400	07-08	HF152	•				
	400 Outlander H.O XT	400	07-08	HF152	•				
	400 Outlander Max EFI	400	09-15	HF152	•				
	400 Outlander Max EFI XT	400	09-15	HF152	•				
	400 Outlander Max H.O	400	07-08	HF152	•				
	400 Outlander Max H.O XT	400	07-08	HF152	•				
	425 Defender DPS (HD5 Engine)	425	17						
	425 Traxter (HD5 Engine)	425	17-18	HF152	•				
	450 EFI	450	09-15	HF560	•				
	450 EFI X mx	450	09-15	HF560	•				
	450 EFI X xc	450	09-15	HF560	•				
	450 Outlander L DPS EFI	450	16-17	HF152	•				
	450 Outlander L EFI	450	15-18	HF152	•				
	450 Outlander L Max DPS EFI	450	16-17	HF152	•				
	450 Outlander L Max EFI	450	15-18	HF152	•				
	450 X	450	08	HF560	•				
	500 Outlander EFI	500	09-15	HF152	•				
	500 Outlander EFI DPS	500	13-14	HF152	•				
	500 Outlander EFI XT	500	09-14	HF152	•				
	500 Outlander EFI XT-P	500	14	HF152	•				
	500 Outlander H.O EFI	500	07-08	HF152	•				
	500 Outlander H.O EFI XT	500	07-08	HF152	•				
	500 Outlander L EFI	500	15	HF152	•				
	500 Outlander L Max EFI	500	15	HF152	•				
	500 Outlander Max EFI	500	09-13	HF152	•				
	500 Outlander Max EFI DPS	500	13	HF152	•				
	500 Outlander Max EFI XT	500	09-13	HF152	•				
	500 Outlander Max H.O EFI	500	07-08	HF152	•				
	500 Outlander Max H.O EFI XT	500	07-08	HF152	•				
	500 Renegade EFI	500	08-15	HF152	•				
	500 Renegade X xc EFI	500	14	HF152	•				
	570 Outlander DPS EFI	570	16	HF152	•				
	570 Outlander L EFI	570	16-18	HF152	•				
	570 Outlander L LE EFI	570	16	HF152	•				
	570 Outlander L Max DPS EFI	570	16-17	HF152	•				
	570 Outlander L Max EFI	570	16-18	HF152	•				
	570 Outlander L Max mr EFI	570	16	HF152	•				
	570 Outlander L Mossy Oak Hunting Edition EFI	570	16-17	HF152	•				
	570 Outlander Max XT EFI	570	17	HF152	•				
	570 Outlander T3 Max EFI PRO	570	18	HF152	•				
	570 Outlander X mr	570	17	HF152	•				
	570 Outlander XT EFI	570	16-17	HF152	•				
	570 Renegade EFI	570	16-18	HF152	•				
	570 Renegade X mr	570	17	HF152	•				
	650 Outlander 6x6 DPS	650	17	HF152	•				
650 Outlander 6x6 EFI	650	15-18	HF152	•					
650 Outlander 6x6 XT EFI	650	16	HF152	•					
650 Outlander DPS	650	13-17	HF152	•					
650 Outlander EFI	650	09-18	HF152	•					
650 Outlander EFI X mr	650	15-17	HF152	•					

MARCA MAKE	MODELLO MODEL	CC CC	ANNO YEAR	OLIO OIL	RICAMBIO FILTRO DI SERIE REPLAC. FOR OE FILTER	DISPONIBILE VER- SIONE SPECIALE SPECIAL TYPE AVAILABLE	ARIA AIR	RICAMBIO FILTRO DI SERIE REPLAC. FOR OE FILTER
CAN-AM	650 Outlander EFI XT	650	09-17	HF152	•			
	650 Outlander EFI XT-P	650	14	HF152	•			
	650 Outlander H.O EFI	650	07-08	HF152	•			
	650 Outlander H.O EFI XT	650	07-08	HF152	•			
	650 Outlander Max EFI	650	09-18	HF152	•			
	650 Outlander Max EFI DPS	650	13-17	HF152	•			
	650 Outlander Max EFI XT	650	09-17	HF152	•			
	650 Outlander Max EFI XT-P	650	12	HF152	•			
	650 Outlander Max H.O EFI	650	07-08	HF152	•			
	650 Outlander Max H.O EFI XT	650	07-08	HF152	•			
	650 Outlander T3 Max EFI	650	18	HF152	•			
	650 Outlander X mr	650	14	HF152	•			
	800 Defender DPS / XT / XT CAB (HD8 Engine)	800	16-17	HF152	•			
	800 Defender Max DPS / XT (HD8 Engine)	800	16-17	HF152	•			
	800 Outlander H.O EFI	800	07-08	HF152	•			
	800 Outlander H.O EFI XT	800	07-08	HF152	•			
	800 Outlander Max H.O EFI	800	07-08	HF152	•			
	800 Outlander Max H.O EFI Ltd / XT	800	07-08	HF152	•			
	800 R Outlander EFI	800	09-15	HF152	•			
	800 R Outlander EFI DPS	800	13-14	HF152	•			
	800 R Outlander EFI X xc	800	10-12	HF152	•			
	800 R Outlander EFI XMR	800	15	HF152	•			
	800 R Outlander EFI XT	800	09	HF152	•			
	800 R Outlander EFI XT / XT-P	800	10-13	HF152	•			
	800 R Outlander EFI XT mr	800	10-12	HF152	•			
	800 R Outlander Max EFI	800	09-15	HF152	•			
	800 R Outlander Max EFI DPS	800	13-14	HF152	•			
	800 R Outlander Max EFI Ltd.	800	09-14	HF152	•			
	800 R Outlander Max EFI XT	800	09-13	HF152	•			
	800 R Outlander Max EFI XT-P	800	11-14	HF152	•			
	800 R Renegade EFI	800	08-15	HF152	•			
	800 R Renegade EFI X	800	08-10	HF152	•			
	800 R Renegade EFI X xc	800	11-14	HF152	•			
	800 SSV Maverick Trail EFI	800	18	HF152	•			
	800 SSV R Commander	800	11-18	HF152	•			
	800 SSV R Commander DPS	800	13-17	HF152	•			
	800 SSV R Commander XT	800	12-17	HF152	•			
	800 Traxter (HD8 Engine)	800	16-18	HF152	•			
	800 Traxter MAX (HD8 Engine)	800	18	HF152	•			
	850 Outlander DPS	850	16-17	HF152	•			
	850 Outlander EFI X mr	850	16-17	HF152	•			
	850 Outlander Max EFI	850	18	HF152	•			
	850 Outlander Max Ltd.	850	16	HF152	•			
	850 Outlander Max XT	850	17	HF152	•			
	850 Outlander Max XT-P	850	17	HF152	•			
850 Outlander XT	850	16-17	HF152	•				
850 Outlander XT-P	850	16-17	HF152	•				
850 Renegade EFI	850	16-18	HF152	•				
850 Renegade X xc	850	16-17	HF152	•				
900 Maverick 900HO	900	18						

FILTRI HIFLO ATV - UTV

MARCA MAKE	MODELLO MODEL	CC CC	ANNO YEAR	OLIO OIL	RICAMBIO FILTRO DI SERIE REPLAC. FOR OE FILTER	DISPONIBILE VER- SIONE SPECIALE SPECIAL TYPE AVAILABLE	ARIA AIR	RICAMBIO FILTRO DI SERIE REPLAC. FOR OE FILTER
CAN-AM	900 Maverick X3 / X / X rs (154hp)	900	17					
	900 Maverick X3 Turbo (120hp)	900	18					
	900 Maverick X3 Turbo R (172hp)	900	18					
	900 Maverick X3 Turbo R X (172hp)	900	18					
	975 Defender DPS / XT / XT CAB (HD10 Engine)	975	16-17	HF152	•			
	975 Defender Max DPS / XT (HD10 Engine)	975	16-17	HF152	•			
	975 Defender Mossy Oak Hunter Ed. (HD10 Engine)	975	16-17	HF152	•			
	975 Traxter (HD10 Engine)	975	17-18	HF152	•			
	975 Traxter MAX (HD10 Engine)	975	18	HF152	•			
	975 Traxter Xmr (HD10 Engine)	975	18	HF152	•			
	990 GS Spyder Engine	990	08	HF564	•			
	990 GS Spyder (Filter for Extended Filter Cover) Filter	990	08		•			
	990 GS Spyder (Filter for Original Shorter Filter Cover) Transmission Filter	990	08	HF559				
	990 GS Spyder SE5 Engine	990	09	HF564	•			
	990 GS Spyder SE5 (Filter for Extended Filter Cover) Filter	990	09		•			
	"990 GS Spyder SE5 (Filter for Original Shorter Filter Transmission Filter Cover)" Transmission Filter	990	09	HF559				
	990 GS Spyder SM5	990	09	HF564	•			
	990 RS Spyder SE5 Engine Filter	990	10-12	HF564	•			
	"990 RS Spyder SE5 Engine Filter Transmission Filter"	990	13-15		•			
	990 RS Spyder SE5 (Filter for Extended Filter Cover) Transmission Filter	990	10-12					
	"990 RS Spyder SE5 (Filter for Original Shorter Filter Transmission Filter Cover)" Filter	990	10-12	HF559				
	990 RS Spyder SM5	990	10-12	HF564				
	990 RS Spyder SM5	990	13-15		•			
	990 RT Spyder SE5 Engine Filter	990	10-12	HF564	•			
	990 RT Spyder SE5 (Filter for Extended Filter Cover) Transmission Filter	990	10-12					
	"990 RT Spyder SE5 (Filter for Original Shorter Filter Transmission Filter Cover)" Filter	990	10-12	HF559				
	990 RT Spyder SE5 / Ltd. Engine Filter Transmission Filter	990	13-14		•			
	990 RT Spyder SM5	990	13					
	990 RT Spyder SM5	990	10-12	HF564				
	990 RT Spyder SMS LTD	990	11-12	HF564				
	990 RT Spyder SM6 / Ltd.	990	14		•			
	990 ST Spyder SE5 / Ltd. Engine Filter Transmission Filter	990	13-15					
	990 ST Spyder SM5	990	13-15		•			
CF MOTO	700 X-Lander	700		HF682	•			
	CF118 Engine 500cc	500		HF682	•			
	CF500 - 3	500		HF682	•			
	CF500 - 5 / 5A	500		HF682	•			
DINLI	450 DL901	450	05-08	HF112	•			
	450 DL901 DMX	450	07-08	HF112	•			
	450 DL902	450		HF112	•			
	460 DL 904 DMX	460	08-	HF112	•			
GOES	450 X	450		HF682	•			
	520 CUV UTX	520		HF682	•			
	520/520 Max	520		HF682	•			
	625i X6 Max 4x4	625		HF682	•			
	625i X6 Max 4x4 Ltd.	625		HF682	•			
	725i S	725		HF682	•			
HISUN	400 HS ATV-2	800		HF112	•			
HISU	800 HS UTV	800		HF152				
HONDA	MUV700 Big Red	700	12-13	HF111	•			

MARCA MAKE	MODELLO MODEL	CC CC	ANNO YEAR	OLIO OIL	RICAMBIO FILTRO DI SERIE REPLAC. FOR OE FILTER	DISPONIBILE VER- SIONE SPECIALE SPECIAL TYPE AVAILABLE	ARIA AIR	RICAMBIO FILTRO DI SERIE REPLAC. FOR OE FILTER	
HONDA	SXS1000 Pioneer 1000 M3,M3L,M3P 1st Oil Filter 2nd Oil Filter	1000	16-18	HF114 HF117	•				
	SXS1000 Pioneer 1000 M5D,MSL,M5P 1st Oil Filter 2nd Oil Filter	1000	16-18	HF114 HF117	•				
HYOVSUNG	SXS500 M PIONEER 500	500	15-16	HF113	•				
	SXS700 M2,M2D,M4,M4D Pioneer 700	700	14-18	HF111	•		HFF1029	X	
JOHN DEERE	TE 450	450	08-11	HF682	•				
	500 Buck	500	05	HF557	•				
	500 Buck EX / EXT	500	05	HF557	•				
	500 Trail Buck	500	05	HF557	•				
KAWASAKI	650 Trail Buck	650	05	HF556	•				
	650 Trail Buck EX / EXT	650	05	HF556	•				
	KAF1000 AGF-AJF Mule PRO-DXT Diesel	1000	16-18						
	KAF1000 BGF-BJF Mule PRO-DXT EPS Diesel	1000	16-18						
	KAF1000 CGF-CHF Mule PRO-DXT EPS LE Diesel	1000	16-17						
	KAF1000 DGF-DHF Mule PRO-DX Diesel	1000	16-17						
	KAF1000 EGF-EJF Mule PRO-DX EPS Diesel	1000	16-18						
	KAF1000 FGF-FHF Mule PRO-DX EPS LE Diesel	1000	16-17						
	KAF300 A1 B1-B2 MULE 500	300			HF128	•			
	KAF300 C1-C7 MULE 550	300			HF128	•			
	KAF300 D1-D2 MULE 520	300			HF128	•			
	KAF400 A1,A6F,A7F,A8F,A9F,AAF-AFF MULE 610 4x4	400	05-15		HF128	•			
	KAF400 B1,B6F,B7F,BAF,B9F,BAF-BGF MULE 600	400	05-16		HF128	•			
	KAF400 C1,C6F-C9F MULE 610 4x4 Hardwo Green HD	400	05-09		HF128	•			
	KAF400 CAF MULE 610 4x4 Realtree APG HD	400	10		HF128	•			
	"KAF400 DAF-DGF,ECF-EGF,FEF-FGF,GGF MULE 610 4x4 XC / Camo / SE / Fleet"	400	10-16		HF128	•			
	KAF400 EBF MULE 610 4x4 Realtree APG HD	400	11		HF128	•			
	KAF400 HJF,JJF,KJF,LJF,MJF,NJF MULE SX	400	18		HF128	•			
	KAF450 B1 MULE 1000	450			HF303	•	RC	HFA2405	X
	KAF540 C1,D1,E1 MULE 2010 / 2020 / 2030	540			HF303	•	RC		
	KAF620 A1-A6 MULE 2510 4x4	620			HF128	•			
	KAF620 B1-B6 MULE 2520	620			HF128	•			
	KAF620 C1-C6 MULE 2500	620			HF128	•			
	KAF620 E1-E5,E6F,E7F,E8F MULE 3010 4 x 4	620			HF128	•			
	KAF620 F1-F3 MULE 3020	620			HF128	•			
	KAF620 G1-G5,G6F,G7F,G8F MULE 3000	620			HF128	•			
	KAF620 H1 MULE 3010 4 x 4 Advantage Classic	620			HF128	•			
	KAF620 H2-H3,H6F,H7F,H8F MULE 3010 4 x 4 Hardwo Green HD	620			HF128	•			
	KAF620 J1,J6F,J7F,J8F MULE 3010 Trans4x4	620			HF128	•			
	KAF620 K1,K6F,K7F,K8F MULE 3010 Trans4x4 Hardwo Green HD	620			HF128	•			
	KAF620 M9F,MAF,MBF-MJF MULE 4010 4x4	620			HF128	•			
	KAF620 N9F MULE 4010 4x4 Hardwo Green HD	620			HF128	•			
KAF620 P9F,PAF-PJF MULE 4000	620			HF128	•				
KAF620 R9F,RAF-RJF MULE 4010 Trans 4x4	620			HF128	•				
KAF620 S9F MULE 4010 Trans 4x4 Hardwo Green HD	620			HF128	•				
KAF620 SAF,SBF MULE 4010 Trans 4x4 Realtree APG HD	620			HF128	•				
KAF620 SEF-SJF MULE 4010 Trans 4x4 Camo	620			HF128	•				
KAF620 TGF-TJF MULE 4010 4x4 SE	620			HF128	•				
KAF620 VGF-VJF MULE 4010 Trans 4x4 Camo SE	620			HF128	•				
KAF620 WJF MULE 4000 Trans 4x4	620				•				
KAF820 EJF Mule PRO-FX	820	18		HF129	•				
KAF820 FJF Mule PRO-FX	820	18		HF129	•				

FILTRI HIFLO ATV - UTV

MARCA MAKE	MODELLO MODEL	CC CC	ANNO YEAR	OLIO OIL	RICAMBIO FILTRO DI SERIE REPLAC. FOR OE FILTER	DISPONIBILE VER- SIONE SPECIALE SPECIAL TYPE AVAILABLE	ARIA AIR	RICAMBIO FILTRO DI SERIE REPLAC. FOR OE FILTER
KAWASAKI	KAF820 GJF Mule PRO-FX	820	18	HF129	•			
	KAF820 Mule PRO-FXT Ranch Edition	820	16	HF129	•			
	KAF820AJF Mule PRO-FXT	820	18	HF129	•			
	KAF820BFF-BJF Mule PRO-FXT EPS	820	15-18	HF129	•			
	KAF820CFF-CJF Mule PRO-FXT EPS LE	820	15-18	HF129	•			
	KAF820DFF-DJF Mule PRO-FXT EPS Camo	820	15-18	HF129	•			
	KAF820JJF Mule PRO-FXT	820	18	HF129	•			
	KAF950 A1-A3 Mule 2510 Diesel 4x4	950	00-03	HF129	•			
	KAF950 B1-B3,B6F,B7F,D8F Mule 3010 Diesel 4x4	950	04-08	HF129	•			
	KAF950 C7F,E8F,F9F,FAF,FBF Mule 3010 Trans 4x4 Diesel	950	07-11	HF129	•			
	KAF950 F9F,FAF,FBF,FCF,DFE,FEF Mule 4010 Diesel 4x4	950	09-15	HF129	•			
	KAF950 G9F,GAF,GBF,GCF,GDF,GEF Mule 4010 Trans 4x4 Diesel	950	09-15	HF129	•			
	KAF950 HAF Mule 4010 Trans 4x4 Diesel Realtree APG HD	950	10	HF129	•			
	KRF750 A8F, B8F Teryx 4x4	750	08	HF204	•	RC		
	KRF750 C8F, D8F Teryx 4x4 LE	750	08	HF204	•	RC		
	KRF750 F8F Teryx 4x4 NRA Outdoors	750	08	HF204	•	RC		
	KRF750 G9F,NAF,NBF,NCS,NDF Teryx 4x4 FI	750	09-13	HF204	•	RC		
	KRF750 J9FA,K9F,PAF-PDF,RAF-RDF Teryx 4x4 FI LE	750	09-13	HF204	•	RC		
	KRF750 K9F,M9F Teryx 4x4 FI NRA Outdoors	750	09	HF204	•	RC		
	KRF750 L9F,L9FA,SAF-SDF Teryx 4x4 FI LE Sport	750	09-13	HF204	•	RC		
	KRF750 TAF Teryx 4x4 FI SGE	750	10	HF204	•	RC		
	KRF750 VBF,VCS Teryx 4x4 FI SGE LE	750	11-12	HF204	•	RC		
	KRF800 FJF,GJF,GJFA,HJF Teryx	800	18	HF204	•	RC		
	KRT800 BEF-BGF,CEF-CGF,DEF-DGF,HJF Teryx4 / LE / Camo	800	14-18	HF204	•	RC		
	KRT800 FJF,GJF,GJFA,HJF Teryx4	800	18	HF204	•	RC		
Teryx4 750 4x4 / EPS / LE	750	13	HF204	•	RC			
KTM	"450 SC ATV"	450	09-11	HF650	•		HFF5016	X
	"450 XC ATV 1st Oil Filter 2nd Oil Filter"	450	08-11	HF155 HF157	•		HFF5016	X
	505 SX ATV	505	09-12	HF650	•		HFF5016	X
	"525 XC ATV 1st Oil Filter 2nd Oil Filter"	525	08-11	HF155 HF157	•		HFF5016	X
KYMCO	375 MXU / MAXEER	375	08-12	HF138	•	RC		
	400 MXU (ATV)	400	08-12	HF138	•	RC		
	450 MXU i / Maxxer i	450	11-15	HF138	•	RC		
	500 MXU / XL	500	06-15	HF147	•			
	500 UXV 4x4	500	08-15	HF147	•			
	550 MXU i.e.	550	11-12	HF147	•			
	700 MXU i.e.	700	13	HF147	•			
PGO	125/150 ALORA	125		HF197	•			
	1000 General 4P MD / PS	1000	18	HF198	•			
POLARIS	1000 General EPS	1000	18	HF198	•			
	1000 Ranger PS	1000	18	HF198	•			
	1000 Ranger PS HD MD	1000	18	HF198	•			
	1000 Ranger XP PS MUD	1000	18	HF198	•			
	1000 RZR 1000 XP / MD EPS	1000	14-18	HF198	•			
	1000 RZR 1000 XP 4 / MD EPS	1000	14-18	HF198	•			
	1000 Scrambler HP H.O. EPS	1000	14-15	HF199	•			
	1000 Scrambler HP H.O. EPS INTL	1000	14-15	HF199	•			
	1000 Scrambler XP	1000	16-18	HF199	•			
	1000 Sportsman HL	1000	16	HF199	•			
	1000 Sportsman Touring	1000	16	HF199	•			

MARCA MAKE	MODELLO MODEL	CC CC	ANNO YEAR	OLIO OIL	RICAMBIO FILTRO DI SERIE REPLAC. FOR OE FILTER	DISPONIBILE VER- SIONE SPECIALE SPECIAL TYPE AVAILABLE	ARIA AIR	RICAMBIO FILTRO DI SERIE REPLAC. FOR OE FILTER	
POLARIS	1000 Sportsman Touring XP	1000	18	HF199	•				
	1000 Sportsman XP	1000	16-18	HF199	•				
	1000 Sportsman XP High Lifting	1000	18	HF199					
	1000 Sportsman XP Hunter	1000	18	HF199	•				
	200 PHOENIX (FOAM AIR FILTER OUTER COVER)			05-18	HF197	•		HFF7012	•
	200 Sawtooth	200	06-07	HF197	•				
	250 Trail Blazer (Foam air filter outer cover)	250	01-07					HFF7012	•
	300 Hawkeye 2x4,4x4 (Foam air filter outer cover)	300	07-11	HF303	•	RC		HFF7012	•
	300 Sportsman (Foam air filter outer cover)	300	08-10	HF303	•	RC		HFF7012	
	325 Ace	325	15-16	HF116	•				
	325 Hawkeye 2x4,4x4	325	15	HF303	•	RC			•
	325 Magnum 2x4,4x4	325	00-02	HF303	•	RC		HFF7011	
	325 Ranger ETX	325	15	HF116	•				
	325 RANGER ETX	325	16	HF116	•				
	325 Sportsman ACE / ETX	325	14-15	HF116	•				•
	325 Trail Boss	325	00-02	HF303	•	RC		HFF7011	•
	325 Xpedition	325	00-02	HF303	•	RC		HFF7011	
	330 ATP	330	04-05	HF303	•	RC			
	330 Hawkeye 2x4,4x4	330	06	HF303	•	RC			•
	330 Magnum 2x4,4x4	330	03-06	HF303	•	RC		HFF7011	•
	330 Magnum 4x4 Mossy Oak	330	04	HF303	•	RC		HFF7011	•
	330 Trail Blazer	330	08-11	HF303	•	RC		HFF7011	•
	330 Trail Blazer	330	12-13	HF199	•			HFF7011	•
	330 Trail Boss	330	03-11	HF303	•	RC		HFF7011	•
	330 Trail Boss	330	12-13	HF199	•			HFF7011	•
	335 Sportsman	335	99-01	HF303	•	RC		HFF7011	•
	335 Worker	335	99	HF303	•	RC		HFF7011	•
	400 Hawkeye HO 2x4	400	11	HF303	•	RC		HFF7011	•
	400 Hawkeye HO 2x4	400	12-14	HF199	•			HFF7011	•
	400 Ranger	400	11-13	HF303	•			RC	
	400 Ranger 4x4 H.O.	400	10	HF303	•			RC	
	400 Sportsman 4x4	400	01-05	HF303	•	RC		HFF7011	•
	400 Sportsman H.O. 4x4	400	08-11	HF303	•	RC		HFF7011	•
	400 Sportsman H.O. 4x4	400	12-14	HF199	•			HFF7011	
	400L Xplorer	400	96-01	HF303	•	RC			
	425 Magnum 2x4,4x4	425	95-98	HF303	•	RC			
	425 Magnum 6x6	425	96-97	HF303	•	RC			•
	425 Ranger	425	01-03	HF303	•			RC	
	425 Xpedition	425	00-02	HF303	•	RC		HFF7011	
	"450 Outlaw MXR / S 1st Oil Filter 2nd Oil Filter"	450	08-09	HF155 HF157	•				•
	450 Sportsman	450	06-07	HF303	•	RC		HFF7011	
	450 Sportsman H.O.	450	18	HF199	•				
450 Sportsman H.O. Utility Edition	450	18	HF199	•					
500 Ace	500	18	HF198	•				•	
500 ATP HO	500	04-05	HF303	•	RC				
500 Big Boss 6x6	500	98-99	HF303	•	RC				
500 Magnum	500	00-02	HF303	•	RC		HFF7011		
500 Outlaw	500	06-07	HF112	•					
500 Predator	500	03-07	HF112	•					
500 Predator Troy Lee Edition	500	05	HF112	•				•	

FILTRI HIFLO ATV - UTV

MARCA MAKE	MODELLO MODEL	CC CC	ANNO YEAR	OLIO OIL	RICAMBIO FILTRO DI SERIE REPLAC. FOR OE FILTER	DISPONIBILE VER- SIONE SPECIALE SPECIAL TYPE AVAILABLE	ARIA AIR	RICAMBIO FILTRO DI SERIE REPLAC. FOR OE FILTER	
POLARIS	500 Ranger	500	18	HF198	•				
	500 Ranger 2x4, 4x4, 4x4, 6x6 EFI / LE	500	06-13	HF303	•		RC		
	500 Ranger Crew / EFI / LE	500	11-13	HF303	•		RC		
	500 Scrambler 4x4	500	12	HF199	•		HFF7011	•	
	500 Scrambler 4x4	500	96-11	HF303	•	RC	HFF7011	•	
	500 Sportsman 6x6	500	08	HF303	•	RC	HFF7011	•	
	500 Sportsman 6x6	500	00-07	HF303	•	RC	HFF7011	•	
	500 Sportsman EFI	500	06-10	HF303	•	RC	HFF7011	•	
	500 Sportsman EFI Touring	500	08-10	HF303	•	RC	HFF7011	•	
	500 Sportsman EFI Touring H.O.	500	11	HF303	•	RC	HFF7011	•	
	500 Sportsman EFI Touring H.O.	500	12-13	HF199	•		HFF7011	•	
	500 Sportsman Forest / Forest Tractor	500	12-14	HF199	•		HFF7011	•	
	500 Sportsman HO	500	00-11	HF303	•	RC	HFF7011	•	
	500 Sportsman HO	500	12-13	HF199	•		HFF7011	•	
	500 Sportsman HO Mossy Oak	500	04	HF303	•	RC	HFF7011	•	
	500 Sportsman X2	500	06-07	HF303	•	RC	HFF7011	•	
	500 Sportsman X2 EFI	500	08-09	HF303	•	RC	HFF7011	•	
	500 Worker	500	99-01	HF303	•	RC		•	
	500 Xplorer 4x4	500	97	HF303	•	RC	HFF7011		
	"525 Outlaw / IRS 1st Oil Filter 2nd Oil Filter"	525	07-11	HF155 HF157	•				•
	550 Sportsman EFI	550	11-14	HF199	•		HFF7011	•	
	550 Sportsman EFI EPS	550	11-14	HF199	•		HFF7011	•	
	550 Sportsman Forest	550	12-14	HF199	•		HFF7011	•	
	550 Sportsman Touring EFI EPS	550	11-14	HF199	•		HFF7011	•	
	550 Sportsman X2 EFI	550	11-13	HF199	•		HFF7011	•	
	550 Sportsman X2 EFI INLT / EPS / LE UE	550	14	HF199	•		HFF7011		
	550 Sportsman XP EFI	550	09-10	HF199	•				
	550 Sportsman XP EFI LE Browning / EPS	550	09-11	HF199	•				
	550 Sportsman XP EFI w/EPS	550	09-10	HF199	•				
	550 Sportsman XP EPS HD INTL	550	14	HF199	•				
	550 Sportsman XP Touring EPS	550	12	HF199	•				
	570 Ace EFI	570	16-18	HF198	•				
	570 Ranger RZR / EFI / Full Size / Crew / FS / PS	570	12-18	HF198	•				
	570 Ranger RZR EPS Trail LE	570	13	HF198					
	570 Sportsman 6x6	570	18	HF199	•				
	570 Sportsman EFI	570	14-18	HF199	•				
	570 Sportsman EFI EPS	570	14-18	HF199	•				
	570 Sportsman EFI HD	570	14-16	HF199	•				
	570 Sportsman EFI UTE HD / MD EPS	570	14-16	HF199	•				
	570 Sportsman EFI X2 EPS	570	16	HF199	•				
	570 Sportsman Forest	570	14-16	HF199	•				
	570 Sportsman Forest EFI EPS	570	14-16	HF199	•				
	570 Sportsman SP MD	570	16-18	HF199	•				
	570 Sportsman SP Touring	570	16-18	HF199	•				
	570 Sportsman Touring EFI	570	14-16	HF199	•				
	570 Sportsman Touring EFI INTL	570	14-16	HF199	•				
	570 Sportsman Touring Tractor EFI	570	16	HF199	•				
570 TR	570	15	HF199	•					
600 Sportsman	600	03	HF196	•					
600 Sportsman Twin (built after 10/2/03)	600	04-06	HF198	•				•	

MARCA MAKE	MODELLO MODEL	CC CC	ANNO YEAR	OLIO OIL	RICAMBIO FILTRO DI SERIE REPLAC. FOR OE FILTER	DISPONIBILE VER- SIONE SPECIALE SPECIAL TYPE AVAILABLE	ARIA AIR	RICAMBIO FILTRO DI SERIE REPLAC. FOR OE FILTER
POLARIS	600 Sportsman Twin (built before 10/2/03)	600	04	HF196	•			
	650 Ranger TM	650	04-06		•			
	700 Ranger 6x6 EFI	700	07-09	HF198	•			
	700 Ranger Crew	700	09	HF198	•			
	700 Ranger HD	700	09	HF198	•			
	700 Ranger XP	700	08-09	HF198	•			
	700 Sportsman MV7	700	06		•			•
	700 Sportsman Twin	700	02-04	HF196	•		HFF7011	•
	700 Sportsman Twin	700	04-06	HF198	•		HFF7011	•
	700 Sportsman Twin EFI	700	05-07	HF198			HFF7011	
	700 Sportsman X2 EFI	700	08	HF198			HFF7011	
	800 Ranger 4x4, 6x6 EFI / EPS / Miize / LE	800	10-13	HF198	•			
	800 Ranger Crew	800	11-13	HF198	•			
	800 Ranger Crew EPS LE	800	12-13	HF198	•			
	800 Ranger HD	800	11-12	HF198	•			
	800 Ranger RZR	800	08-16	HF198	•			
	800 Ranger RZR 4	800	12-13	HF198	•			
	800 Ranger RZR 4 EPS LE	800	12-13	HF198	•			
	800 Ranger RZR EPS LE	800	12-13	HF198	•			
	800 Ranger RZR LE	800	13	HF198	•			
	800 Ranger RZR S	800	09-15	HF198	•			
	800 Ranger RZR S LE	800	13	HF198	•			
	800 Ranger XP	800	11-12	HF198	•			
	800 Ranger XP EPS	800	12	HF198	•			
	800 Sportsman 6x6 EFI	800	14	HF198	•		HFF7011	•
	800 Sportsman 6x6 Forest EFI	800	14	HF198	•		HFF7011	•
	800 Sportsman Big Boss 6x6	800	11-13	HF198	•		HFF7011	•
	800 Sportsman EFI	800	06-14	HF198	•		HFF7011	•
	800 Sportsman Forest EFI	800	14	HF198	•		HFF7011	•
	800 Sportsman H.O. EFI	800	08-09	HF198	•		HFF7011	•
	800 Sportsman Touring EFI	800	08-09	HF198	•		HFF7011	•
	800 Sportsman Twin	800	05	HF198	•		HFF7011	•
	800 Sportsman X2 EFI	800	07-09	HF198	•		HFF7011	•
	850 Scrambler	850	16-18	HF199	•			•
	850 Sportsman Forest	850	14-15	HF199	•			
	850 Sportsman High Lifter Edition	850	18	HF199	•			•
	850 Sportsman SP	850	16-18	HF199	•			
	850 Sportsman Touring EFI EPS	850	11	HF199	•		HFF7011	•
	850 Sportsman Touring EFI LE Super Graphite EPS	850	11	HF199	•		HFF7011	•
	850 Sportsman Touring H.O. EPS	850	12-15	HF199	•		HFF7011	•
	850 Sportsman Touring H.O. EPS LE	850	13	HF199	•		HFF7011	
	850 Sportsman Touring SP	850	18	HF199	•			•
850 Sportsman WV	850	14	HF199	•		HFF7011		
850 Sportsman X2 EFI LE	850	11	HF199	•		HFF7011		
850 Sportsman XP EFI	850	11	HF199	•				
850 Sportsman XP EFI EPS	850	09-11	HF199	•				
850 Sportsman XP EFI LE Browning	850	09-10	HF199	•				
850 Sportsman XP EFI LE Browning EPS	850	11	HF199	•				
850 Sportsman XP EFI LE Nuclear Sunset	850	09	HF199	•				
850 Sportsman XP EFI LE Orange Madness EPS	850	11	HF199	•				

FILTRI HIFLO ATV - UTV

MARCA MAKE	MODELLO MODEL	CC CC	ANNO YEAR	OLIO OIL	RICAMBIO FILTRO DI SERIE REPLAC. FOR OE FILTER	DISPONIBILE VER- SIONE SPECIALE SPECIAL TYPE AVAILABLE	ARIA AIR	RICAMBIO FILTRO DI SERIE REPLAC. FOR OE FILTER
POLARIS	850 Sportsman XP H.O.	850	12-13	HF199	•			
	850 Sportsman XP H.O. EPS	850	12-15	HF199	•			
	850 Sportsman XP H.O. EPS LE	850	13	HF199	•			
	900 Ace EFI EPS / XC	900	16-18	HF198	•			
	900 Ranger 50 Inch / 60 Inch	900	18	HF198				
	900 Ranger Crew XP	900	18	HF198	•			
	900 Ranger Diesel	900	11					
	900 Ranger RZR XP	900	11-18	HF199	•			
	900 Ranger RZR XP 4	900	13	HF198	•			
	900 Ranger RZR XP 4 EPS LE	900	13	HF198	•			
	900 Ranger RZR XP EFI	900	13-15	HF198	•			
	900 Ranger RZR XP EPS LE	900	13-15	HF198	•			
	900 Ranger RZR XP LE	900	13	HF198	•			
	900 Ranger XP	900	13	HF198	•			
	900 Ranger XP LE	900	13	HF198	•			
	904 Ranger Diesel / Crew	904	12-13		•			
	925 RZR XP Turbo / MD / S	925	18	HF198	•			
	925 RZR XP4 Turbo / MD	925	18	HF198	•			
	MV800 4x4	800	07		•			•
	QUADZILLA	450 R / RS / SPORT	450		HF112	•		
500 CUV E 2x4 / 4x4		500		HF682	•			
500 ES 4x4		500		HF682	•			
500 RS5 2x4 / 4x4		500		HF682	•			
500 XLC		500		HF682	•			
600 RS 6 EFI		600		HF682	•			
TGB	400 AVANGER LE / R	400	07-10	HF148	•			
	400 Target E / LE	400	06-10	HF148	•			
	425 Avenger	425	07-10	HF148	•			
	425 Blade	425	08-10	HF148	•			
	425 Outback	425	07-08	HF148	•			
	425 Target	425		HF148	•			
	450 Blade SE	450	10-	HF148	•			
	500 Avenger R	500		HF148	•			
	500 Blade R	500	10-14	HF148	•			
	500 Target R 4x2 / 4x4	500	10-14	HF148	•			
	525 Blade R IRS / SE	525	09-14	HF148	•			
	525 Target	525	08-10	HF148	•			
	550 Blade	550	09-14	HF148	•			
	550 Blade LT IRS	550	09-14	HF148	•			
	550 Target IRS	550	10-14	HF148	•			
YAMAHA	YXC700 VDX-F,G,H,J VI Viking	700	15-18	HF204	•	RC		
	YXC700 VPA-J VI Viking EPS	700	18	HF204	•	RC		
	YXC700 VPH-F,G,H,J VI Viking Hunter EPS	700	15-18	HF204	•	RC		
	YXC700 VPR-G,H,J VI Viking Ranch Edition EPS	700	16-18	HF204	•	RC		
	YXC700 VPS-F,G,H VI Viking EPS SE	700	15-17	HF204	•	RC		
	YXC700 VPX-F,G,H,J VI Viking EPS	700	15-18	HF204	•	RC		
	YXE700 WDB-J Wolverine R-Spec	700	18	HF204	•	RC		
	YXE700 WDH-G Wolverine R-Spec Hunter	700	16	HF204	•	RC		
	YXE700 WDX-G Wolverine R-Spec	700	16	HF204	•	RC		
	YXE700 WPA-J Wolverine R-Spec	700	18	HF204	•	RC		

MARCA MAKE	MODELLO MODEL	CC CC	ANNO YEAR	OLIO OIL	RICAMBIO FILTRO DI SERIE REPLAC. FOR OE FILTER	DISPONIBILE VER- SIONE SPECIALE SPECIAL TYPE AVAILABLE	ARIA AIR	RICAMBIO FILTRO DI SERIE REPLAC. FOR OE FILTER
YAMAHA	YXE700 WPH-G,H,J Wolverine R-Spec EPS Hunter	700	16-18	HF204	•	RC		
	YXE700 WPX-G,H Wolverine R-Spec EPS	700	16-17	HF204	•	RC		
	YXF850 WPA-J Wolverine	850	18	HF204	•	RC		
	YXF850 WPH-J Wolverine	850	18	HF204	•	RC		
	YXF850 WPS-J Wolverine X4 SE	850	18	HF204	•	RC		
	YXM700 VDH-H Viking	700	17	HF204	•	RC		
	YXM700 VDX-F,G,H,J Viking	700	15-18	HF204	•	RC		
	YXM700 VPA-H,J Viking EPS	700	17-18	HF204	•	RC		
	YXM700 VPH-G,H,J Viking Hunter EPS	700	15-18	HF204	•	RC		
	YXM700 VPR-J Viking EPS Ranch Edition	700	18	HF204	•	RC		
	YXM700 VPS-G,H Viking EPS SE	700	15-17	HF204	•	RC		
	YXM700 VPX-F,G,H,J Viking EPS	700	15-18	HF204	•	RC		
	YXR450 Rhino AUTO 4X4	450	06-09	HF303	•	RC		
	YXR660 Rhino	660	04-06	HF303	•	RC		
	YXR660 Rhino Exploring Edition / Special Edition	660	06	HF303	•	RC		
	YXR660 Rhino Hardwood Camo.	660	04-05	HF303	•	RC		
	YXR700 F-X,Y,A,B,D Rhino FI Auto 4x4	700	08-13	HF204	•	RC		
	YXR700 FDU-X,Y Rhino FI Auto 4x4 Ducks Unlimited Ed.	700	08-09	HF204	•	RC		
	YXR700 FH-A,B,D Rhino Hunter Auto 4x4	700	11-13	HF204	•	RC		
	YXR700 FSE-X,Y Rhino FI Auto 4x4 SE	700	08-09	HF204	•	RC		
	YXR700 FSP-X,Y,A,B,D Rhino FI Auto 4x4 Sport Ed.	700	08-13	HF204	•	RC		
	YZX1000 Viking EPS SE	700	16	HF204	•	RC		
	YZX1000 R YES-H EPS SS SE	700	17	HF204	•	RC		
YZX1000 R YEX-H EPS SS	700	17	HF204	•	RC			
YZX1000 R YMS-H EPS SE	700	17	HF204	•	RC			
YZX1000 R YMX-H EPS	700	17	HF204	•	RC			

FILTRI HI FLO
ATV UTC

MOTORPARTS
YOUR QUALITY SUPPLIER

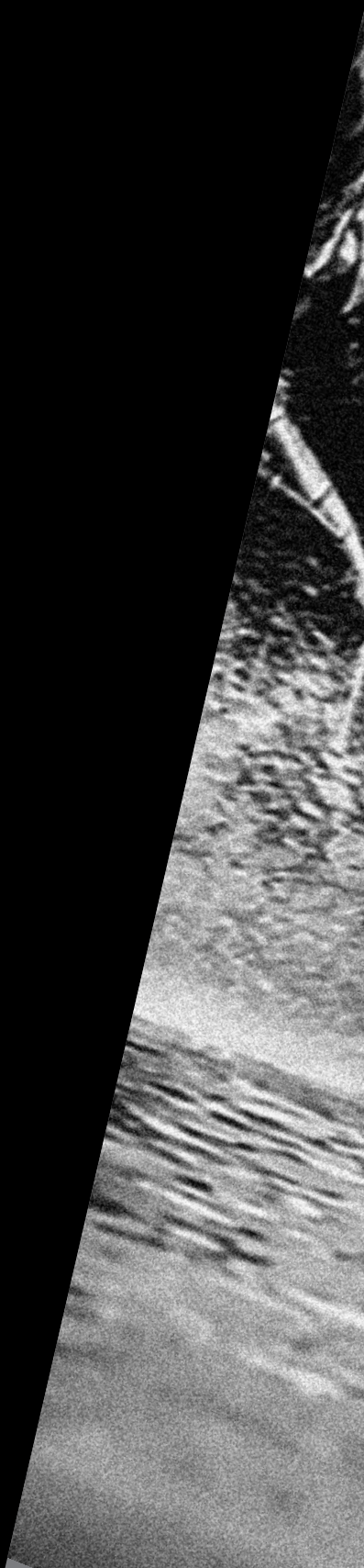



***FILTRI HIFLO
MARINE***

FILTRI HIFLO - MARINE

MARCA MAKE	MODELLO MODEL	ANNO YEAR	NUMERO DI SERIE SERIAL NUMBER	FILTRO OLIO OIL FILTER	RIFERIMENTO ORIGINALE OE Part Number
HONDA OUTBOARD	115 hp	00-06	up to 1102862	HF 148	15400-PLM-A01PE
	115 hp	07-	1102863-	HF 148	15400-PLM-A02
	130 hp	00-04		HF 148	15400-PLM-A01PE
	135 hp	05-		HF 148	15400-PLM-A01PE
	15 hp	03-		HF 204	15400-PFB-014
	150 hp	04-	1010961-	HF 148	15400-PLM-A01PE
	20 hp	03-		HF 204	15400-PFB-014
	200 hp	02-07	up to 1101744	HF 148	15400-PLM-A01PE
	200 hp	07-	1101745-	HF 148	15400-PLM-A02
	225 hp	02-06	up to 1107491	HF 148	15400-PLM-A01PE
	225 hp	07-	1107492-	HF 148	15400-PLM-A02
	25 hp	01-05	up to 1003206	HF 303	15400-PFB-007
	25 hp	05-	1003207 -	HF 204	15400-PFB-014
	30 hp	01-05	up to 1005016	HF 303	15400-PFB-007
	30 hp	05-	1005017-	HF 204	15400-PFB-014
	40 hp	01-05	up to 3007642	HF 303	15400-PFB-007
	40 hp	05-	3007643-	HF 204	15400-PFB-014
	50 hp	00-05	up to 3014456	HF 303	15400-PFB-007
	50 hp	05-	3014457-	HF 204	15400-PFB-014
	75 hp	00-		HF 148	15400-PLM-A01PE
9.9 hp	01-		HF 204	15400-PFB-014	
90 hp	00-		HF 148	15400-PLM-A01PE	
HONDA PERSONAL WATERCRAFT	AquaTrax F-12	02-07		HF 204	15410-MFJ-D01
	AquaTrax F-12X	02-07		HF 204	15410-MFJ-D01
	AquaTrax F-12X GPScape	05-07		HF 204	15410-MFJ-D01
	AquaTrax F-15	09		HF 204	15410-MFJ-D01
	AquaTrax F-15X	08-09		HF 204	15410-MFJ-D01
	AquaTrax F-15X GPScape	08-09		HF 204	15410-MFJ-D01
	AquaTrax R-12	04-06		HF 204	15410-MFJ-D01
KAWASAKI PERSONAL WATERCRAFT	AquaTrax R-12X	03-07		HF 204	15410-MFJ-D01
	Jet Ski STX	09-10		HF 303	16097-0004
	Jet Ski STX 15F	04-10		HF 303	16097-0004
	Jet Ski STX 15F	11-17		HF 204	16097-0003 / 0007
	Jet Ski STX-12F	03-07		HF 303	16097-0004
	Jet Ski Ultra 250X	07-08		HF 204	16097-0003
	Jet Ski Ultra 260LX	09-12		HF 204	16097-0003
	Jet Ski Ultra 260X	09-12		HF 204	16097-0003
	Jet Ski Ultra 300LX	11-12		HF 204	16097-0003
	Jet Ski Ultra 300X	11-12		HF 204	16097-0003
	Jet Ski Ultra 310LX	14-17		HF 204	16097-0003 / 0007
	Jet Ski Ultra 310R	14-17		HF 204	16097-0003 / 0007
	Jet Ski Ultra 310X	14-17		HF 204	16097-0003 / 0007
	Jet Ski Ultra 310X SE	14-17		HF 204	16097-0003 / 0007
	Jet Ski Ultra LX	07-11		HF 303	16097-0004
Jet Ski Ultra LX	12-17		HF 204	16097-0003 / 0007	
MERCURY / MARINER OUTBOARD	FourStroke 100 EFI		up to 1B366822	HF 148	822626K04 / 35-822626K04
	FourStroke 115 EFI		0T178500 - 1B366822	HF 148	822626K04 / 35-822626K04
	Fourstroke 25 Carb		0G590000 - 0G760299	HF 204	822626K03 / 35-822626K03
	Fourstroke 25 Carb		0G760300 - 1B344298	HF 148	822626K04 / 35-822626K04
	FourStroke 25 EFI		0R106999 -	HF 204	822626K03 / 35-822626K03

MARCA MAKE	MODELLO MODEL	ANNO YEAR	NUMERO DI SERIE SERIAL NUMBER	FILTRO OLIO OIL FILTER	RIFERIMENTO ORIGINALE OE Part Number
MERCURY / MARINER OUTBOARD	Fourstroke 30 Carb		0P153500 -	HF 148	822626K04 / 35-822626K04
	FourStroke 30 EFI		0T409000 - 1B226999	HF 148	822626K04 / 35-822626K04
	OUTBOARD		0R106999-	HF 204	822626K03 / 35-822626K03
	FourStroke 30 EFI		1C109093-	HF 148	822626K04 / 35-822626K04
	FourStroke 40 Carb (3 cyl)		0P153500-	HF 148	822626K04 / 35-822626K04
	FourStroke 40 EFI (3 cyl)		ALL	HF 148	822626K04 / 35-822626K04
	FourStroke 40 EFI (4 cyl)		ALL	HF 148	822626K04 / 35-822626K04
	FourStroke 40 EFI Jet (4 cyl)		1C051324-	HF 148	822626K04 / 35-822626K04
	FourStroke 50 EFI (4 cyl)		ALL	HF 148	822626K04 / 35-822626K04
	FourStroke 60 EFI (4 cyl)		ALL	HF 148	822626K04 / 35-822626K04
	FourStroke 75 EFI		up to 1B366822	HF 148	822626K04 / 35-822626K04
	FourStroke 80 EFI		up to 1B366822	HF 148	822626K04 / 35-822626K04
	FourStroke 90 EFI		up to 1B366822	HF 148	822626K04 / 35-822626K04
	FourStroke Jet 25		0R165086 -	HF 204	822626K03 / 35-822626K03
NISSAN OUTBOARD	NSF 15		ALL	HF 199	3R0-07615-0
	NSF 20		ALL	HF 199	3R0-07615-0
	NSF 25		ALL	HF 199	3R0-07615-0
	NSF 30		ALL	HF 199	3R0-07615-0
SEA-DOO PERSONAL WATERCRAFT	GTI	06		HF 556	420956741
	GTI 130	08-12		HF 556	420956741
	GTI 4-TEC	07		HF 556	420956741
	GTI 4-TEC Rental	07		HF 556	420956741
	GTI 4-TEC SE	07		HF 556	420956741
	GTI Limited 155	11-16		HF 556	420956741
	GTI Rental	06		HF 556	420956741
	GTI Rental 130	08		HF 556	420956741
	GTI SE	06		HF 556	420956741
	GTI SE 155/130	08-16		HF 556	420956741
	GTR 215	12-16		HF 556	420956741
	GTS 130	11-16		HF 556	420956741
	GTX	07		HF 556	420956741
	GTX 215/155	08-12		HF 556	420956741
	GTX 4-TEC	02-06		HF 556	420956741
	GTX 4-TEC LTD	03-06		HF 556	420956741
	GTX 4-TEC SC (Supercharged)	03-06		HF 556	420956741
	GTX 4-TEC WAKE	03-06		HF 556	420956741
	GTX iS 215	10-11		HF 556	420956741
	GTX Limited iS 260	10-16		HF 556	420956741
	GTX LTD	07		HF 556	420956741
	GTX S 155	12-16		HF 556	420956741
	GTX WAKE	07		HF 556	420956741
	RXP	04-07		HF 556	420956741
	RXP-X 255	08-11		HF 556	420956741
	RXP-X 260	12-16		HF 556	420956741
RXT	05-07		HF 556	420956741	
RXT 260	11-16		HF 556	420956741	
RXT iS 260	10-12		HF 556	420956741	
RXT-X 260	10-16		HF 556	420956741	
RXT-X aS 260	10-16		HF 556	420956741	
Wake 155	08-16		HF 556	420956741	

FILTRI HIFLO - MARINE

MARCA MAKE	MODELLO MODEL	ANNO YEAR	NUMERO DI SERIE SERIAL NUMBER	FILTRO OLIO OIL FILTER	RIFERIMENTO ORIGINALE OE Part Number
SEA-DOO PERSONAL WATERCRAFT SUZUKI OUTBOARD	Wake Pro 215	08-16		HF 556	420956741
	DF140	02-10		HF 129	16510-82703
TOHATSU OUTBOARD	DF140	11-	14002F-110001 -	HF 129	16510-82703
	DF15	11-	01503F-110001 -	HF 131	16510-05240
	DF15	96-10		HF 131	16510-05240
	DF9.9 / 9.9A	11-	00993F-110001-	HF 131	16510-05240
	DF9.9 / 9.9A	96-10		HF 131	16510-05240
	MFS 15	All		HF 199	37-3R0076150
YAMAHA OUTBOARD	MFS 20	All		HF 199	37-3R0076150
	MFS 25	All		HF 199	37-3R0076150
	MFS 30	All		HF 199	37-3R0076150
	F100	00-03		HF 303	5GH-13440-00-00
	F115	00-05		HF 303	5GH-13440-00-00
	F115 In Line Four	06-		HF 303	5GH-13440-00-00
	F115 Jet Drive	06-		HF 303	5GH-13440-00-00
	F15	00-05		HF 303	5GH-13440-00-00
	F15 Portable	06-		HF 204	5GH-13440-20-00
	F150	04-05		HF 740	69J-13440-01-00
	F150 In Line Four	06-		HF 740	69J-13440-01-00
	F150 Jet Drive	06-		HF 740	69J-13440-01-00
	F20 Portable	06-		HF 204	5GH-13440-20-00
	F200	02-05		HF 740	69J-13440-01-00
	F200 High Power	06-		HF 740	69J-13440-01-00
	F225	02-05		HF 740	69J-13440-01-00
	F225 High Power	06-		HF 740	69J-13440-01-00
	F225 V6 Offshore	11-		HF 750	N26-13440-00-00
	F25	00-05		HF 303	5GH-13440-00-00
	F25 Midrange	06-		HF 204	5GH-13440-20-00
	F250	05		HF 740	69J-13440-01-00
	F250 High Power	06-		HF 740	69J-13440-01-00
	F250 V6 Offshore	11-		HF 750	N26-13440-00-00
	F30	01-05		HF 303	5GH-13440-00-00
	F300 V6 Offshore	11-		HF 750	N26-13440-00-00
	F350 V8 5.3l	06-		HF 750	N26-13440-00-00
	F40	00-05		HF 303	5GH-13440-00-00
	F40 Jet Drive	06-		HF 204	5GH-13440-20-00
	F40 Midrange	06-		HF 303	5GH-13440-00-00
	F50	00-05		HF 303	5GH-13440-00-00
F50 Midrange	06-		HF 204	5GH-13440-20-00	
F60	02-05		HF 303	5GH-13440-00-00	
F60 Jet Drive	06-		HF 204	5GH-13440-20-00	
F60 Midrange	06-		HF 204	5GH-13440-20-00	
F70 Midrange	06-		HF 204	5GH-13440-20-00	
F75	03-05		HF 303	5GH-13440-00-00	
F75 Midrange	06-		HF 303	5GH-13440-00-00	
F80	00-03		HF 303	5GH-13440-00-00	
F90	03-05		HF 303	5GH-13440-00-00	
F90 Jet Drive	06-		HF 303	5GH-13440-00-00	
F90 Midrange	06-		HF 303	5GH-13440-00-00	
Sport Model 225	06-		HF 740	69J-13440-01-00	

MOTORPARTS
YOUR QUALITY SUPPLIER



***ATV - UTV
ELECTRIC PARTS***

ELECTRIC PARTS ATV - UTV

MARCA MAKE	MODELLO MODEL	CC CC	DA FROM	A TO	ALTERNATORE ALTERNATORE	CENTRALINA CDI	GENERATORE GENERATOR
ALIEN MOTORS	Desert Rat 50						
	Mohave 110						
	Rockstar 150						
ARCTIC CAT	150	149cc	2009	2014			
	150	149cc	2015	2016			
	300	270cc	2010	2015			
	350	366cc	2011	2012			
	400	366cc	2013	2015			
	425	443cc	2011	2012			
	450	443cc	2011	2015			
	550	550cc	2009	2014			
	650	550cc	2010	2012			
	700	695cc	2011	2014			
	1000 EFI H2 4x4 Auto Mud Pro	951cc	2010	2013			
	1000 EFI H2 4x4 Auto Mud Pro	951cc	2014	2015			
	1000 EFI H2 4x4 Auto TRV	951cc	2010	2011			
	1000 H2 Cruiser	951cc	2009	2009			
	1000 LTD	951cc	2011	2011			
	1000 TRV	951cc	2009	2013			
	1000 TRV	951cc	2009	2015			
	1000 TRV Cruiser	951cc	2009	2011			
	1000 TRV Cruiser	951cc	2009	2013			
	1000 XT	951cc	2013	2014			
	1000 XT	951cc	2014	2014			
	1000i GT	951cc	2012	2012			
	1000i GT	951cc	2012	2013			
	250 2x4	--L 249cc -cid	2006	2009			
	250 2x4	249cc	1999	2005			
	250 4x4	249cc	2001	2005			
	300 2x4	280cc	1998	2002			
	300 2x4	280cc	1998	2003			
	300 2x4 Auto	280cc	2010	2010			
	300 2x4 Auto		2011	2016			
	300 4x4	280cc	1998	2002			
	300 4x4	280cc	1998	2005			
	366 4x4 Auto SE	366cc	2011	2011			
	375 Auto 2x4	375cc	2002	2002			
	375 Auto 4x4	375cc	2002	2002			
	400 2x4	376cc	1998	2002			
	400 2x4	376cc	1998	2004			
	400 2x4	376cc	2003	2004			
	400 2x4 Auto	376cc	2003	2004			
	400 2x4 FIS	376cc	2002	2002			
	400 2x4 FIS		2003	2007			
400 2x4 FIS		2007	2008				
400 4x4	376cc	1998	2002				
400 4x4	376cc	1998	2004				
400 4x4	376cc	2003	2007				
400 4x4 ACT	376cc	2003	2004				
400 4x4 Auto	376cc	2003	2008				

ELECTRIC PARTS ATV - UTV

MARCA MAKE	MODELLO MODEL	CC CC	DA FROM	A TO	ALTERNATORE ALTERNATORE	CENTRALINA CDI	GENERATORE GENERATOR
ARCTIC CAT	400 4x4 Auto ACT	376cc	2003	2004			
	400 4x4 Auto LE	376cc	2005	2007			
	400 4x4 Auto MRP	376cc	2003	2004			
	400 4x4 Auto TBX	376cc	2004	2006			
	400 4x4 Auto TRV	376cc	2006	2008			
	400 4x4 Auto TRV	376cc	2007	2010			
	400 4x4 Auto TRV		2011	2014			
	400 4x4 Auto TRV Plus	376cc	2007	2007			
	400 4x4 Auto VP	376cc	2005	2006			
	400 4x4 FIS	376cc	2002	2002			
	400 4x4 FIS		2003	2007			
	400 4x4 Man		2003	2005			
	400 4x4 VP	376cc	2005	2006			
	400 Man		2002	2002			
	425i	443cc	2012	2012			
	425i SE	443cc	2012	2012			
	450 Core	443cc	2012	2013			
	450 EFI H1 4x4 Auto	443cc	2010	2012			
	450 LTD	443cc	2011	2011			
	450 TRV	443cc	2011	2011			
	450 TRV		2012	2012			
	450i	443cc	2012	2012			
	450i GT	443cc	2012	2012			
	500 4x4	493cc	1998	1999			
	500 4x4	493cc	1998	2001			
	500 4x4	493cc	2002	2009			
	500 4x4 Auto	493cc	2000	2005			
	500 4x4 Auto	493cc	2000	2009			
	500 4x4 Auto	493cc	2007	2009			
	500 4x4 Auto FIS	493cc	2002	2002			
	500 4x4 Auto LE	493cc	2005	2006			
	500 4x4 Auto MRP	493cc	2003	2004			
	500 4x4 Auto TBX	493cc	2002	2006			
	500 4x4 Auto TRV	493cc	2003	2008			
	500 4x4 Auto TRV	493cc	2008	2008			
	500 4x4 Auto TRV		2007	2013			
	500 4X4 Hunter Automatic LE		2001	2001			
	500 Core	443cc	2013	2013			
	500 Core	443cc	2013	2015			
	500 Man		2000	2002			
	500 Man		2002	2002			
	500 XT	443cc	2013	2014			
	500 XT	443cc	2013	2015			
	550 4x4 Auto	545cc	2009	2011			
	550 4x4 Auto LE	545cc	2009	2010			
	550 4x4 Auto TRV	545cc	2009	2011			
	550 4x4 Auto TRV LE	545cc	2009	2009			
	550 Core	545cc	2013	2013			
	550 EFI		2010	2010			
	550 EFI TRV		2010	2015			

BOBINE ACCENSIONE IGNITION COILS	REGOLATORI & RADDRIZZATORI REGULATORS & RECTIFIERS	KIT RIPARAZIONE REPAIR KIT	INTERRUTTORI SOLENOIDI SOLENOID SWITCH	MOTORINI AVVIAMENTO STARTER	INGRANAGGI AVVIAMENTO STARTER DRIVES	KIT RIPARAZIONE MOTORINI AVVIAMENTO STARTER REPAIR KIT	STATORI STATORS
			67-766				
			67-766				
				18809N			
				18809N			
				18790N			
				18809N			
				18809N			
				18809N			
				18790N			
				16077N			
				16077N			
				16077N			
				16077N			
				16077N			
			67-766	16077N			
				16077N			
			67-766	16077N			
			67-766				
				16077N			
				16077N			
			67-748				
				18790N			
				18796N			
			67-748				
				18796N			
			67-766				
				18790N			
				18796N			
				18796N			
				18796N			
				18796N			
			67-766				
			67-766				
				18796N			
			67-766				
				16077N			
			67-748				
				18790N			
			67-766				
				16077N			
				18882N			
				18882N			
				18882N			
				18882N			
				18882N			
			67-766	18882N			
				18882N			
				18882N			
			67-766	18882N			
				18882N			

ELECTRIC PARTS
ATV - UTV

ELECTRIC PARTS ATV - UTV

MARCA MAKE	MODELLO MODEL	CC CC	DA FROM	A TO	ALTERNATORE ALTERNATORE	CENTRALINA CDI	GENERATORE GENERATOR
ARCTIC CAT	550 GT		2012	2012			
	550 GT Cruiser		2012	2012			
	550 H1 EFI	545cc	2009	2009			
	550 H1 EFI		2010	2011			
	550 LTD	545cc	2011	2014			
	550 LTD	545cc	2014	2014			
	550 LTD		2012	2015			
	550 PS		2011	2011			
	550 PS Cruiser		2011	2012			
	550 S	545cc	2011	2011			
	550 TRV		2009	2011			
	550 TRV Cruiser	545cc	2011	2011			
	550 TRV Cruiser		2012	2012			
	550 TRV GT	545cc	2011	2011			
	550 TRV GT	545cc	2011	2012			
	550 TRV GT		2012	2012			
	550 TRV LTD		2013	2014			
	550 TRV LTD		2013	2015			
	550 TRV XT		2013	2014			
	550 TRV XT		2013	2015			
	550 XR		2015	2015			
	550 XR LTD		2015	2015			
	550 XR XT		2015	2015			
	550 XT	545cc	2013	2015			
	550 XT EFT		2013	2013			
	550i	545cc	2012	2014			
	550i GT	545cc	2012	2012			
	550i LTD	545cc	2012	2013			
	550S EFI TRV		2010	2010			
	550TRV EFT		2013	2013			
	650 4x4 Auto	641cc	2004	2004			
	650 4x4 Auto LE	641cc	2004	2004			
	650 4x4 Auto TBX	641cc	2009	2009			
	650 H1		2011	2011			
	650 H1 4x4 Auto	641cc	2005	2007			
	650 H1 4x4 Auto	641cc	2007	2010			
	650 H1 4x4 Auto	641cc	2008	2011			
	650 H1 4x4 Auto		2009	2009			
	650 H1 4x4 Auto LE	641cc	2007	2007			
	650 H1 4x4 Auto Mud Pro	641cc	2010	2011			
	650 H1 4x4 Auto Mud Pro		2012	2012			
	650 H1 4x4 Auto SE	641cc	2006	2006			
	650 H1 4x4 Auto TBX	641cc	2007	2007			
	650 H1 4x4 Auto TRV	641cc	2008	2008			
	650 H1 4x4 Auto TRV	641cc	2008	2009			
	650 H1 4x4 Auto TRV		2007	2007			
	650 H1 4x4 Auto TRV Plus	641cc	2007	2007			
650 H1 4x4 Auto TRV Plus LE	641cc	2007	2007				
650 H1 FIS		2007	2007				
650 H1 FIS		2007	2008				

BOBINE ACCENSIONE IGNITION COILS	REGOLATORI & RADDRIZZATORI REGULATORS & RECTIFIERS	KIT RIPARAZIONE REPAIR KIT	INTERRUTTORI SOLENOIDI SOLENOID SWITCH	MOTORINI AVVIAMENTO STARTER	INGRANAGGI AVVIAMENTO STARTER DRIVES	KIT RIPARAZIONE MOTORINI AVVIAMENTO STARTER REPAIR KIT	STATORI STATORS
			67-766	18882N			
			67-766				
				18882N			
			67-766				
			67-766				
				18882N			
				18882N			
			67-766	18882N			
			67-766	18882N			
				18882N			
			67-766				
			67-766				
				18882N			
			67-766				
			67-766				
				18882N			
				18882N			
				18882N			
				18882N			
				18882N			
				18882N			
			67-766	18882N			
				18882N			
				18842N			
				18842N			
				18882N			
				18882N			
				18796N			
			67-766				
				18882N			
			67-766				
				18882N			
			67-766	18882N			
			67-766				
				18796N			
				18796N			
			67-766				
				18796N			
			67-766	18882N			
				18882N			
				18882N			
				18796N			
			67-766				
				18882N			

ELECTRIC PARTS
ATV - UTV

ELECTRIC PARTS ATV - UTV

MARCA MAKE	MODELLO MODEL	CC CC	DA FROM	A TO	ALTERNATORE ALTERNATORE	CENTRALINA CDI	GENERATORE GENERATOR
ARCTIC CAT	650 Mud Pro		2011	2011			
	650 TBX		2007	2009			
	650 TBX		2009	2009			
	650 TRV		2009	2009			
	650 V-2 4x4 Auto	641cc	2004	2006			
	650 V-2 4x4 Auto LE/TS	641cc	2004	2006			
	650 V-2 4x4 Auto MRP	641cc	2004	2004			
	650 V-Twin FIS		2004	2006			
	700 Core	695cc	2013	2013			
	700 Cruiser		2012	2012			
	700 Diesel	695cc	2007	2008			
	700 Diesel	695cc	2007	2013			
	700 Diesel	695cc	2007	2014	13127N		
	700 EFI 4x4 Auto	695cc	2007	2008			
	700 EFI 4x4 Auto LE	695cc	2007	2007			
	700 EFI 4x4 Auto M4	695cc	2008	2008			
	700 EFI 4x4 Auto SE	695cc	2006	2006			
	700 EFI 4x4 Auto TRV Cruiser	695cc	2008	2008			
	700 EFI 4x4 Auto TRV Cruiser	695cc	2009	2011			
	700 EFI 4x4 Auto TRV LE	695cc	2008	2008			
	700 EFI FIS		2007	2007			
	700 EFI H1 4x4 Auto	695cc	2009	2010			
	700 EFI H1 4x4 Auto LE	695cc	2009	2010			
	700 EFI H1 4x4 Auto Mud Pro	695cc	2009	2011			
	700 EFI H1 4x4 Auto Mud Pro	695cc	2011	2011			
	700 EFI H1 4x4 Auto Mud Pro		2012	2013			
	700 EFI H1 4x4 Auto SE	695cc	2008	2009			
	700 EFI H1 4x4 Auto TBX	695cc	2010	2010			
	700 EFI H1 4x4 Auto TRV	695cc	2009	2011			
	700 EFI TRV		2010	2010			
	700 EFI TRV LE		2008	2008			
	700 GT		2011	2012			
	700 GT		2012	2012			
	700 H1		2009	2011			
	700 H1 EFI		2008	2010			
	700 H1 EFI		2008	2011			
	700 LTD	695cc	2011	2014			
	700 LTD		2015	2015			
	700 Mud Pro		2009	2013			
	700 Mud Pro LTD		2012	2014			
	700 Mud Pro LTD		2012	2015			
	700 PS Cruiser		2011	2011			
	700 S	695cc	2010	2011			
	700 Super Duty Diesel	670cc	2010	2010			
	700 Super Duty Diesel	686cc	2011	2015			
	700 TBX		2010	2015			
	700 TBX GT		2012	2012			
700 TBX PS		2011	2011				
700 TRV		2007	2011				
700 TRV		2011	2011				

BOBINE ACCENSIONE IGNITION COILS	REGOLATORI & RADDRIZZATORI REGULATORS & RECTIFIERS	KIT RIPARAZIONE REPAIR KIT	INTERRUTTORI SOLENOIDI SOLENOID SWITCH	MOTORINI AVVIAMENTO STARTER	INGRANAGGI AVVIAMENTO STARTER DRIVES	KIT RIPARAZIONE MOTORINI AVVIAMENTO STARTER REPAIR KIT	STATORI STATORS
			67-766				
				18882N			
				18882N			
				18842N			
				18842N			
				18842N			
				18842N			
				18842N			
			67-766	18882N			
				18882N			
				18882N			
				18365N			
			67-766				
				18810N			
			67-766	18810N			
				18810N			
				18810N			
				18882N			
				18810N			
				18810N			
				18882N			
			67-766	18882N			
				18882N			
			67-766				
			67-766				
				18882N			
			67-766	18882N			
				18882N			
				18882N			
				18810N			
			67-766	18882N			
				18882N			
			67-766				
				18882N			
			67-766	18882N			
				18882N			
				18882N			
			67-766	18882N			
				18882N			
				18365N			
				18365N			
			67-766	18882N			
				18882N			
				18882N			
			67-766				
				18882N			

ELECTRIC PARTS
ATV - UTV

ELECTRIC PARTS ATV - UTV

MARCA MAKE	MODELLO MODEL	CC CC	DA FROM	A TO	ALTERNATORE ALTERNATORE	CENTRALINA CDI	GENERATORE GENERATOR
ARCTIC CAT	700 TRV Cruiser		2009	2011			
	700 TRV Cruiser		2009	2012			
	700 TRV GT	695cc	2010	2011			
	700 TRV GT	695cc	2011	2011			
	700 TRV GT		2012	2012			
	700 TRV LTD		2013	2014			
	700 TRV LTD		2013	2015			
	700 TRV XT		2013	2014			
	700 TRV XT		2013	2015			
	700 XR		2015	2015			
	700 XR LTD		2015	2015			
	700 XR XT		2015	2015			
	700 XT	695cc	2013	2015			
	700i	695cc	2012	2012			
	700i GT	695cc	2012	2012			
	700i LTD	695cc	2012	2015			
	700S EFI TRV		2010	2010			
	700S H1 EFI		2010	2010			
	700S H1 EFI		2010	2011			
	90 2x4 4-Stroke	89cc	2004	2005			
	Bearcat 454 2x4	454cc	1997	1998			
	Bearcat 454 4x4	454cc	1996	1998			
	Bearcat 570	565cc	2010	2012			
	Bearcat 570		2009	2009			
	Bearcat 570 XT	565cc	2011	2012			
	Bearcat 570 XT	570cc	2009	2010			
	Bearcat Z1 XT	1056cc	2009	2011			
	Bearcat Z1 XT Limited		2011	2011			
	DVX 250	--L 250cc -cid	2006	2008			
	DVX 300	270cc	2009	2010			
	DVX 300	270cc	2009	2014			
	DVX 300	300cc	2011	2015			
	DVX 400	400cc	2004	2008			
	DVX 400 TS	400cc	2006	2007			
	F5 EFI LXR	499cc	2011	2011			
	F5 EFI LXR	500cc	2007	2010			
	F5 EFI LXR		2012	2012			
	F570	565cc	2011	2013			
	F570	570cc	2008	2010			
	F8 EFI LXR	794cc	2011	2011			
	F8 EFI LXR	800cc	2007	2010			
	MudPro 1000	951cc	2011	2011			
	MudPro 1000i LTD	951cc	2012	2013			
	MudPro 650	641cc	2011	2011			
	MudPro 700	695cc	2011	2015			
	MudPro 700i	695cc	2012	2012			
	MudPro 700i LTD	695cc	2012	2014			
Prowler 1000 XT		2015	2015				
Prowler 550	550cc	2009	2009				
Prowler 650 4x4 Auto	650cc	2008	2008				

BOBINE ACCENSIONE IGNITION COILS	REGOLATORI & RADDRIZ- ZATORI REGULATORS & RECTIFIERS	KIT RIPARAZIONE REPAIR KIT	INTERRUTTORI SOLENOIDI SOLENOID SWITCH	MOTORINI AVVIAMENTO STARTER	INGRANAGGI AVVIAMENTO STARTER DRIVES	KIT RIPARAZIONE MOTO- RINI AVVIAMENTO STARTER REPAIR KIT	STATORI STATORS
				18882N			
			67-766				
				18882N			
			67-766				
			67-766				
			67-766				
				18882N			
			67-766				
				18882N			
			67-766				
			67-766				
			67-766				
			67-766	18882N			
				18882N			
				18882N			
				18882N			
				18882N			
			67-766				
				18884N			
			67-748	18790N			
			67-748	18790N			
			67-766				
			67-766				
			67-766				
			67-766				
			67-766				
			67-766				
			67-784	19599N			
			67-784				
				19599N			
			67-784	19599N			
				18718N			
				18718N			
			67-766				
			67-766				
			67-766				
			67-766				
			67-766				
			67-766				
			67-766				
				19879N			
				19879N			
				18882N			
				18882N			
				18882N			
				18882N			
				18882N			
				18882N			
				18882N			

ELECTRIC PARTS
ATV - UTV

ELECTRIC PARTS ATV - UTV

MARCA MAKE	MODELLO MODEL	CC CC	DA FROM	A TO	ALTERNATORE ALTERNATORE	CENTRALINA CDI	GENERATORE GENERATOR
ARCTIC CAT	Prowler 650 H1	650cc	2006	2007			
	Prowler 650 H1	650cc	2007	2007			
	Prowler 650 H1		2008	2008			
	Prowler 650 H1		2008	2009			
	Prowler 650 XT		2009	2009			
	Prowler H1 700		2008	2008			
	Prowler HDX		2011	2012			
	Prowler HDX 500	443cc	2014	2015			
	Prowler HDX 500 Limited	443cc	2014	2014			
	Prowler HDX 500 Limited	443cc	2014	2015			
	Prowler HDX 500 XT	443cc	2014	2014			
	Prowler HDX 500 XT	443cc	2014	2015			
	Prowler HDX 700	695cc	2011	2012			
	Prowler HDX 700	695cc	2011	2013			
	Prowler HDX 700		2014	2014			
	Prowler HDX 700 Limited	695cc	2014	2014			
	Prowler HDX 700 XT	695cc	2015	2015			
	Prowler HDX 700i	695cc	2012	2013			
	Prowler XT		2012	2012			
	Prowler XT 1000	-- 952cc	2015	2015			
	Prowler XT 550	550cc	2010	2012			
	Prowler XT 550	550cc	2010	2015			
	Prowler XT 550	550cc	2013	2015			
	Prowler XT 550i	545cc	2012	2013			
	Prowler XT 650 4x4 Auto	650cc	2008	2008			
	Prowler XT 650 4x4 Auto M4	650cc	2008	2008			
	Prowler XT 650 H1	650cc	2006	2009			
	Prowler XT 650 H1	650cc	2007	2007			
	Prowler XT 700	695cc	2010	2015			
	Prowler XT 700	695cc	2015	2015			
	Prowler XT 700	700cc	2009	2009			
	Prowler XT 700		2008	2008			
	Prowler XTX		2008	2012			
	Prowler XTX 700	695cc	2010	2012			
	Prowler XTX 700	695cc	2010	2014			
	Prowler XTX 700		2008	2009			
	Prowler XTX 700 H1 EFI	695cc	2009	2011			
	Prowler XTX 700 LE	700cc	2008	2009			
	Prowler XTX 700i	695cc	2012	2013			
	Prowler XTZ 1000	1000cc	2008	2013			
	Prowler XTZ 1000	1000cc	2009	2011			
	Prowler XTZ 1000	951cc	2010	2011			
	Prowler XTZ 1000	951cc	2014	2014			
	Prowler XTZ 1000 Baja	1000cc	2009	2009			
	Prowler XTZ 1000 H2 EFI	1000cc	2009	2009			
	Prowler XTZ 1000 H2 EFI	951cc	2010	2011			
	Prowler XTZ 1000i	951cc	2012	2013			
SBS 1000	1000cc	2002	2002				
T570	565cc	2011	2013				
T570	570cc	2008	2010				

BOBINE ACCENSIONE	REGOLATORI & RADDRIZZATORI	KIT RIPARAZIONE	INTERRUTTORI SOLENOIDI	MOTORINI AVVIAMENTO	INGRANAGGI AVVIAMENTO	KIT RIPARAZIONE MOTORINI AVVIAMENTO	STATORI
IGNITION COILS	REGULATORS & RECTIFIERS	REPAIR KIT	SOLENOID SWITCH	STARTER	STARTER DRIVES	STARTER REPAIR KIT	STATORS
				18796N			
			67-766				
				18882N			
			67-766				
				18882N			
				18882N			
				18882N			
			67-766	16077N			
			67-766				
				16077N			
			67-766				
				16077N			
				19879N			
			67-766	18882N			
			67-766				
				18882N			
			67-766	18882N			
				18882N			
			67-766				
				18882N			
				19879N			
				18882N			
			67-766				
				18882N			
				18882N			
				18882N			
				18882N			
				18796N			
			67-766				
			67-766	18882N			
				18882N			
			67-766				
				18882N			
			67-766				
				19879N			
			67-766	18882N			
				18882N			
				18882N			
				18882N			
			67-766	19879N			
				18882N			
				19879N			
			67-766				
				19879N			
				19879N			
				19879N			
			67-766				
			67-766				
				18882N			

ELECTRIC PARTS
ATV - UTV

ELECTRIC PARTS ATV - UTV

MARCA MAKE	MODELLO MODEL	CC CC	DA FROM	A TO	ALTERNATORE ALTERNATORE	CENTRALINA CDI	GENERATORE GENERATOR
ARCTIC CAT	TBX 700	695cc	2014	2014			
	TBX 700 LTD	695cc	2011	2011			
	TBX 700 XT	695cc	2013	2013			
	TBX 700i GT	695cc	2012	2012			
	Thundercat	895cc	2008	2009			
	Thundercat 1000 4x4 Auto	1000cc	2008	2009			
	Thundercat 1000 4x4 Auto	1000cc	2010	2010			
	Thundercat 1000 4x4 Auto LE	1000cc	2010	2010			
	Thundercat H2		2008	2010			
	TRV 1000 LTD	951cc	2013	2013			
	TRV 1000i Cruiser	951cc	2012	2012			
	TRV 1000i GT	951cc	2012	2012			
	TRV 450i	443cc	2012	2012			
	TRV 450i GT	443cc	2012	2012			
	TRV 500 Core	443cc	2013	2015			
	TRV 550 LTD	545cc	2013	2014			
	TRV 550 XT	545cc	2013	2014			
	TRV 550i Crusier	545cc	2012	2012			
	TRV 550i GT	545cc	2012	2012			
	TRV 700 LTD	695cc	2013	2014			
	TRV 700 XT	695cc	2013	2014			
	TRV 700i Cruiser	695cc	2012	2012			
	TRV 700i GT	695cc	2012	2012			
	TZ1	1056cc	2010	2011			
	TZ1		2008	2009			
	TZ1 LXR	1056cc	2010	2011			
	TZ1 Park	1050cc	2009	2009			
	TZ1 Turbo LXR	1050cc	2009	2010			
	TZ1 Turbo LXR	1056cc	2011	2011			
	Wildcat		2014	2015			
	Wildcat 1000		2013	2014			
	Wildcat 1000 LTD	951cc	2013	2013			
	Wildcat 1000 LTD	951cc	2013	2014			
	Wildcat 1000i HO	951cc	2012	2014			
	Wildcat 4 1000	951cc	2013	2014			
	Wildcat 4 Limited	951cc	2014	2014			
	Wildcat 4X	951cc	2014	2015			
	Wildcat 4X Limited	951cc	2014	2015			
	Wildcat Sport	700cc	2015	2015			
	Wildcat Sport Limited	700cc	2015	2015			
	Wildcat Sport XT	700cc	2015	2015			
	Wildcat Trail	700cc	2014	2015			
	Wildcat Trail Limited	700cc	2015	2015			
	Wildcat Trail XT	700cc	2014	2015			
	Wildcat X 1000	951cc	2013	2015			
	Wildcat X 1000	951cc	2014	2015			
	Wildcat X Limited	951cc	2014	2015			
	XC 450i	443cc	2011	2015			
	XC 450i	445cc	2013	2013			
	XR 500	443cc	2015	2015			

BOBINE ACCENSIONE	REGOLATORI & RADDRIZZATORI	KIT RIPARAZIONE	INTERRUTTORI SOLENOIDI	MOTORINI AVVIAMENTO	INGRANAGGI AVVIAMENTO	KIT RIPARAZIONE MOTORINI AVVIAMENTO	STATORI
IGNITION COILS	REGULATORS & RECTIFIERS	REPAIR KIT	SOLENOID SWITCH	STARTER	STARTER DRIVES	STARTER REPAIR KIT	STATORS
				18882N			
				18882N			
				18882N			
				18882N			
				19879N			
				18882N			
				18882N			
			67-766				
				18882N			
				18882N			
				18882N			
				16077N			
				16077N			
				16077N			
				18882N			
				18882N			
				18882N			
				18882N			
				18882N			
				18882N			
				18882N			
			67-766				
			67-766				
			67-766				
			67-766				
			67-766				
			67-766				
			67-766				
				19879N			
			67-766				
				19879N			
			67-766				
			67-766				
			67-766				
			67-766				
			67-766				
			67-766				
			67-766				
			67-766				
			67-766				
			67-766				
			67-766				
				19879N			
			67-766				
				16077N			
				16077N			
				16077N			
				18882N			

ELECTRIC PARTS
ATV - UTV

ELECTRIC PARTS ATV - UTV

MARCA MAKE	MODELLO MODEL	CC CC	DA FROM	A TO	ALTERNATORE ALTERNATORE	CENTRALINA CDI	GENERATORE GENERATOR
ARCTIC CAT	XR 550	545cc	2015	2015			
	XR 550 LTD	545cc	2015	2015			
	XR 550 XT	545cc	2015	2015			
	XR 700	695cc	2015	2015			
	XR 700 LTD	695cc	2015	2015			
	XR 700 XT	695cc	2015	2015			
	Z1 Turbo	1100cc	2009	2010			
	Z1 Turbo EXT	1100cc	2010	2011			
	Z1 Turbo LXR	1056cc	2011	2011			
	Z1 Turbo LXR LE		2011	2011			
BAJA MOTORSPORTS	Z1 Turbo Sno Pro	1100cc	2010	2011			
	BA150 Baja 150		2006	2006			
	STR125 Baja Storm 125						
	WD250U Wilderness Trail 250		2006	2010			
	WD50 Baja 50		2006	2006			
	WD50U Baja Wilderness 50		2006	2006			
	WD90 Baja Wilderness 90		2006	2006			
	WD90S Baja Wilderness 90		2006	2006			
	WD90U Baja Canyon 90-U		2006	2006			
	WD90U Baja Wilderness Trail 90		2006	2006			
	WD90UR Baja Wilderness Trail 90R		2006	2006			
	110cc Leopard						
	110cc Sports						
	150cc Sports						
	200cc Sports						
	250cc Utility						
	300cc Utility A 2x4			2005	2008		
	300cc Utility B 2x4			2005	2008		
	400cc Sports						
	400cc Utility						
	400cc Utility A						
	400cc Utility B						
	70cc Formula						
	70cc Premium						
	Bemine 150cc						
	Go Kart 150cc						
	Go Kart 250cc						
	Heritage 150cc						
	Machoman 250cc						
	Pathfinder 150cc						
	Pinnacle 150cc						
	Power Buggy 250cc						
Ranch Pony 400cc							
Robot 150cc							
Romans 150cc							
Teamguys 150cc							
Teamguys 250cc							
BOBCAT	2300	719cc	2008	2010			
	2200S (Diesel)	719cc	2004	2009			
	3400 4x4 (Diesel)	903cc	2011	2015			

BOBINE ACCENSIONE	REGOLATORI & RADDRIZZATORI	KIT RIPARAZIONE	INTERRUTTORI SOLENOIDI	MOTORINI AVVIAMENTO	INGRANAGGI AVVIAMENTO	KIT RIPARAZIONE MOTORINI AVVIAMENTO	STATORI
IGNITION COILS	REGULATORS & RECTIFIERS	REPAIR KIT	SOLENOID SWITCH	STARTER	STARTER DRIVES	STARTER REPAIR KIT	STATORS
				18882N			
				18882N			
				18882N			
				18882N			
				18882N			
			67-766				
			67-766				
			67-766				
			67-766				
			67-766				
				19574N			
				19575N			
				19577N			
				19576N			
				19576N			
				19575N			
				19575N			
				19575N			
				19575N			
				19575N			
				19575N			
				19572N			
				19578N			
				18753N			
				19589N			
				19589N			
				18756N			
				18683N			
				18683N			
				18683N			
				19576N			
				19576N			
				19572N			
				19572N			
				19577N			
				19572N			
				19577N			
				19572N			
				19572N			
				19577N			
				18683N			
				19572N			
				19572N			
				19572N			
				19577N			
				18880N			
				18880N			
				18880N			
			67-784	19599N			

ELECTRIC PARTS
ATV - UTV

ELECTRIC PARTS ATV - UTV

MARCA MAKE	MODELLO MODEL	CC CC	DA FROM	A TO	ALTERNATORE ALTERNATORE	CENTRALINA CDI	GENERATORE GENERATOR
BOBCAT	3400XL 4x4 (Diesel)	904cc	2011	2015			
	3450 4x4	903cc	2011	2012			
	3600 4x4	903cc	2013	2015			
	3600 4x4 Deluxe Package	903cc	2014	2014			
	3650 4x4	903cc	2013	2015			
BOMBARDIER	Commander 1000		2011	2015			
	Commander 800		2011	2015			
	Commander Max 1000		2014	2015			
	DS250	--L 249cc -cid	2006	2006			
	DS250	249cc	2007	2009			
	DS250		2010	2014			
	DS450 EFI		2009	2015			
	DS450 X		2008	2011			
	DS50 Mini		2002	2006			
	DS650	649cc	2000	2002			
	DS650 Baja	649cc	2002	2002			
	DS90 Mini - 2-Stroke		2002	2006			
	DS90 Mini - 4-Stroke		2002	2005			
	DS90 Mini - 4-Stroke		2006	2007			
	Maverick 1000		2013	2015			
	Maverick Max 1000		2014	2015			
	Outlander 1000 EFI		2012	2015			
	Outlander 330 2X4		2004	2005			
	Outlander 330 4X4		2004	2005			
	Outlander 400 2X4		2003	2006			
	Outlander 400 4X4		2003	2009			
	Outlander 400 EFI		2008	2015			
	Outlander 400 XT 4X4		2003	2008			
	Outlander 500 HO EFI		2007	2015			
	Outlander 500 HO EFI XT		2007	2014			
	Outlander 650 HO EFI		2006	2015			
	Outlander 650 HO EFI XT		2006	2012			
	Outlander 6X6		2014	2015			
	Outlander 800 HO EFI		2006	2009			
	Outlander 800 HO EFI XT		2006	2009			
	Outlander 800R EFI		2009	2015			
	Outlander L 450 EFI		2015	2015			
	Outlander L 500 EFI		2015	2015			
	Outlander L Max 450 EFI		2015	2015			
	Outlander L Max 500 EFI		2015	2015			
	Outlander Max 1000 EFI		2013	2015			
	Outlander Max 400 4X4		2004	2009			
	Outlander Max 400 EFI		2008	2015			
	Outlander Max 400 HO	400cc	2004	2006			
	Outlander Max 400 XT 4X4		2005	2006			
	Outlander Max 500 HO EFI		2007	2015			
	Outlander Max 500 HO EFI XT		2007	2013			
Outlander Max 650 HO EFI		2006	2015				
Outlander Max 650 HO EFI XT		2006	2012				
Outlander Max 800 HO EFI		2006	2009				

BOBINE ACCENSIONE	REGOLATORI & RADDRIZZATORI	KIT RIPARAZIONE	INTERRUTTORI SOLENOIDI	MOTORINI AVVIAMENTO	INGRANAGGI AVVIAMENTO	KIT RIPARAZIONE MOTORINI AVVIAMENTO	STATORI
IGNITION COILS	REGULATORS & RECTIFIERS	REPAIR KIT	SOLENOID SWITCH	STARTER	STARTER DRIVES	STARTER REPAIR KIT	STATORS
				19599N			
				19599N			
				19189N			
				19189N			
				18821N			
	51008N						
	4229-124						
				18821N			
				18822N			
				19640N			
				18880N			
				18880N			
				18880N			
				18823N			
				18823N			
				18823N			
				18823N			
				18823N			
				18823N			
				18880N			
				18880N			
				18880N			
				18880N			
				18880N			
				18880N			
				18880N			
				18880N			
				18880N			
				18823N			
				18880N			
				18880N			
				18880N			
				18823N			
				18880N			
				18880N			
				18880N			
				18880N			
				18880N			
				18880N			
				18880N			
				18880N			
				18821N			
				18817N			
				18817N			
				18817N			
				18817N			
				18817N			

ELECTRIC PARTS
ATV - UTV

ELECTRIC PARTS ATV - UTV

MARCA MAKE	MODELLO MODEL	CC CC	DA FROM	A TO	ALTERNATORE ALTERNATORE	CENTRALINA CDI	GENERATORE GENERATOR
BOMBARDIER	Outlander Max 800 HO EFI XT		2006	2009			
	Outlander Max 800R EFI		2009	2015			
	Outlander Max XT 800 4X4		2006	2007			
	Quest 50 - 2-Stroke		2003	2004			
	Quest 500 2X2		2002	2004			
	Quest 500 4X4	499cc	2002	2004			
	Quest 500 XT		2002	2004			
	Quest 650		2002	2004			
	Quest 650 XT		2002	2004			
	Quest 90 4-stroke	89cc	2003	2004			
	Quest Max 650		2004	2004			
	Rally 175		2003	2004			
	Rally 175		2005	2007			
	Rally 200	176cc	2005	2006			
	Renegade 1000 EFI		2012	2015			
	Renegade 500 EFI		2008	2015			
	Renegade 800 EFI		2007	2009			
	Renegade 800 EFI X		2007	2009			
	Renegade 800R EFI		2009	2015			
	Sarasota 1000	--L 249cc -cid	2004	2005			
	Traxter 500		1999	2001			
	Traxter 500 5-Speed		2004	2005			
	Traxter 500 Autoshift		2001	2003			
	Traxter 500 Autoshift XT		2002	2003			
	Traxter 500 CVT (Auto)		2005	2005			
	Traxter 500 Foot Shift		2001	2001			
	Traxter 650 Auto CVT		2005	2005			
	Traxter 650 Max Auto CVT		2005	2005			
	Traxter Max 500		2003	2005			
	Traxter Max XT 500		2004	2005			
	Traxter XL 500		2001	2005			
	Traxter XT 500		2001	2005			
	CAN-AM	Commander 1000	1000cc	2011	2014		
Commander 1000		976cc	2012	2014			
Commander 1000 DPS		976cc	2014	2015			
Commander 1000 LTD		976cc	2012	2015			
Commander 1000 X		976cc	2011	2013			
Commander 1000 X		976cc	2012	2013			
Commander 1000 XT		976cc	2011	2015			
Commander 1000 XT		976cc	2012	2015			
Commander 1000 XT-P		976cc	2014	2015			
Commander 800R		800cc	2011	2015			
Commander 800R DPS		800cc	2015	2015			
Commander 800R XT		800cc	2011	2015			
Commander 800R XT		800cc	2012	2015			
Commander DPS 1000		976cc	2013	2013			
Commander DPS 800R		800cc	2013	2014			
Commander Max 1000 DPS		976cc	2014	2015			
Commander Max 1000 XT		976cc	2014	2015			
Defender HD5		-- 427cc	2017	2017			

BOBINE ACCENSIONE	REGOLATORI & RADDRIZZATORI	KIT RIPARAZIONE	INTERRUTTORI SOLENOIDI	MOTORINI AVVIAMENTO	INGRANAGGI AVVIAMENTO	KIT RIPARAZIONE MOTORINI AVVIAMENTO	STATORI
IGNITION COILS	REGULATORS & RECTIFIERS	REPAIR KIT	SOLENOID SWITCH	STARTER	STARTER DRIVES	STARTER REPAIR KIT	STATORS
				18822N			
				18817N			
				18813N			
				18818N			
				18818N			
				18880N			
				18880N			
				18880N			
				18880N			
				18880N			
				18819N			
				18819N			
				18819N			
				18819N			
				18817N			
				18819N			
				18817N			
				18817N			
				18819N			
				18819N			
				18819N			
				18819N			
				18819N			
	S1005N			18880N			
				18880N			
	S1005N			18880N			
	S1005N			18880N			
				18880N			
				18880N			
	S1005N			18880N			
	S1005N			18880N			
	S1005N			18880N			
				18880N			
				18880N			
				18880N			
	S1005N			18880N			
	S1005N			18880N			
							27-7071
				19599N			
			67-784				
				19189N			
				19189N			
				19189N			
				19189N			
				19189N			
				19189N			
				19189N			
				19189N			
				18821N			
				18880N			
				18880N			
				18880N			

ELECTRIC PARTS
ATV - UTV

ELECTRIC PARTS ATV - UTV

MARCA MAKE	MODELLO MODEL	CC CC	DA FROM	A TO	ALTERNATORE ALTERNATORE	CENTRALINA CDI	GENERATORE GENERATOR
CAN-AM	DS 250	--L 249cc -cid	2007	2015			
	DS 250	--L 249cc -cid	2007	2016			
	DS 450	449cc	2008	2014			
	DS 450 EFI	449cc	2012	2012			
	DS 450 EFI X mx	449cc	2012	2012			
	DS 450 EFI X xc	449cc	2012	2012			
	DS 450 X	449cc	2008	2008			
	DS 450 X mx	449cc	2009	2015			
	DS 450 X xc	449cc	2009	2015			
	DS 50	49cc	2007	2007			
	Maverick 1000R	976cc	2013	2015			
	Maverick 1000R Turbo X ds	976cc	2015	2015			
	Maverick 1000R X ds	976cc	2015	2015			
	Maverick 1000R X mr DPS	976cc	2015	2015			
	Maverick 1000R X rs DPS	976cc	2015	2015			
	Maverick 1000R X xc DPS	976cc	2015	2015			
	Maverick Max 1000R	976cc	2013	2015			
	Maverick Max 1000R Turbo X ds	976cc	2015	2015			
	Maverick Max 1000R X ds	976cc	2015	2015			
	Maverick Max 1000R X rs DPS	976cc	2015	2015			
	Maverick Max X rs DPS 1000R	976cc	2013	2014			
	Maverick X mr 1000R	976cc	2014	2014			
	Maverick X rs 1000R	976cc	2013	2014			
	Maverick X rs DPS 1000R	976cc	2014	2014			
	Maverick X xc DPS 1000R	976cc	2014	2014			
	Outlander 1000 6x6 XT	976cc	2015	2015			
	Outlander 1000 EFI	976cc	2012	2012			
	Outlander 1000 EFI	976cc	2012	2015			
	Outlander 1000 EFI DPS	976cc	2013	2015			
	Outlander 1000 EFI DPS	976cc	2013	2016			
	Outlander 1000 EFI XT	976cc	2012	2014			
	Outlander 1000 EFI XT	976cc	2012	2015			
	Outlander 1000 EFI XT-P	976cc	2013	2014			
	Outlander 1000 EFI XT-P	976cc	2013	2015			
	Outlander 1000 X mr	976cc	2013	2015			
	Outlander 1000 X mr	976cc	2013	2016			
	Outlander 400 EFI	400cc	2011	2014			
	Outlander 400 EFI XT	400cc	2011	2014			
	Outlander 400 HO	400cc	2007	2008			
	Outlander 400 HO EFI	400cc	2008	2010			
	Outlander 400 HO EFI XT	400cc	2008	2010			
	Outlander 400 HO XT	400cc	2007	2008			
	Outlander 500 EFI	500cc	2011	2014			
	Outlander 500 EFI DPS	500cc	2013	2015			
	Outlander 500 EFI XT	500cc	2011	2015			
	Outlander 500 EFI XT	500cc	2012	2015			
	Outlander 500 HO 4x4 EFI	499cc	2007	2010			
Outlander 500 HO 4x4 EFI XT	499cc	2007	2010				
Outlander 500 HO 4x4 EFI XT-P	499cc	2010	2010				
Outlander 650 6x6 XT	650cc	2015	2015				

BOBINE ACCENSIONE IGNITION COILS	REGOLATORI & RADDRIZ- ZATORI REGULATORS & RECTIFIERS	KIT RIPARAZIONE REPAIR KIT	INTERRUTTORI SOLENOIDI SOLENOID SWITCH	MOTORINI AVVIAMENTO STARTER	INGRANAGGI AVVIAMENTO STARTER DRIVES	KIT RIPARAZIONE MOTO- RINI AVVIAMENTO STARTER REPAIR KIT	STATORI STATORS
				18880N			
				18880N			
				18880N			
				18880N			
				18880N			
				18880N			
				18880N			
				18880N			
				18880N			
				18880N			
				18880N			
				18880N			
				18880N			
				18880N			
				18880N			
				18880N			
				18880N			
				18823N			
				18823N			
				18823N			
				18823N			
				18823N			
				18823N			
	S1005N			18880N			
	S1005N			18880N			
				18880N			
				18880N			
				18880N			
	S1005N			18880N			
	S1005N			18880N			
	S1005N			18880N			
				18880N			
				18880N			
				18880N			
	S1005N			18880N			
	S1005N			18880N			
				18880N			
				18880N			
	S1005N			18880N			
				18880N			
				18880N			
				18880N			
				18823N			

ELECTRIC PARTS
ATV - UTV

ELECTRIC PARTS ATV - UTV

MARCA MAKE	MODELLO MODEL	CC CC	DA FROM	A TO	ALTERNATORE ALTERNATORE	CENTRALINA CDI	GENERATORE GENERATOR
CAN-AM	Outlander 650 EFI	650cc	2011	2015			
	Outlander 650 EFI DPS	650cc	2013	2015			
	Outlander 650 EFI XT	650cc	2011	2015			
	Outlander 650 EFI XT	650cc	2012	2015			
	Outlander 650 EFI XT-P	650cc	2010	2011			
	Outlander 650 HO 4x4 EFI	649cc	2007	2010			
	Outlander 650 HO 4x4 EFI XT	649cc	2007	2010			
	Outlander 650 HO 4x4 EFI XT-P	649cc	2010	2010			
	Outlander 650 X mr	650cc	2013	2015			
	Outlander 800 HO 4x4 EFI	799cc	2007	2010			
	Outlander 800 HO 4x4 EFI XT	799cc	2007	2010			
	Outlander 800 HO 4x4 EFI XT-P	799cc	2010	2010			
	Outlander 800R EFI	800cc	2011	2015			
	Outlander 800R EFI DPS	800cc	2013	2015			
	Outlander 800R EFI X mr	800cc	2012	2012			
	Outlander 800R EFI X mr	800cc	2012	2015			
	Outlander 800R EFI X mr	976cc	2013	2013			
	Outlander 800R EFI X xc	800cc	2011	2011			
	Outlander 800R EFI XT	800cc	2011	2015			
	Outlander 800R EFI XT	800cc	2012	2015			
	Outlander 800R EFI XT-P	800cc	2010	2015			
	Outlander 800R EFI XT-P	800cc	2013	2015			
	Outlander L 450	-- 427cc	2015	2015			
	Outlander L 450 DPS	-- 427cc	2015	2015			
	Outlander L 500	500cc	2015	2015			
	Outlander L 500 DPS	500cc	2015	2015			
	Outlander L Max 450	-- 427cc	2015	2015			
	Outlander L Max 450 DPS	-- 427cc	2015	2015			
	Outlander L Max 500	500cc	2015	2015			
	Outlander L Max 500 DPS	500cc	2015	2015			
	Outlander Max 1000 EFI DPS	976cc	2013	2014			
	Outlander Max 1000 EFI DPS	976cc	2013	2015			
	Outlander Max 1000 EFI LTD	976cc	2013	2015			
	Outlander Max 1000 EFI LTD	976cc	2013	2016			
	Outlander Max 1000 EFI XT	976cc	2013	2014			
	Outlander Max 1000 EFI XT	976cc	2013	2015			
	Outlander Max 1000 EFI XT-P	976cc	2013	2014			
	Outlander Max 1000 EFI XT-P	976cc	2013	2015			
	Outlander Max 400 EFI	400cc	2011	2014			
	Outlander Max 400 EFI XT	400cc	2011	2014			
	Outlander Max 400 HO	400cc	2007	2008			
	Outlander Max 400 HO EFI	400cc	2008	2010			
	Outlander Max 400 HO EFI XT	400cc	2008	2010			
	Outlander Max 400 HO XT	400cc	2007	2008			
	Outlander Max 500 EFI	500cc	2011	2014			
Outlander Max 500 EFI DPS	500cc	2013	2014				
Outlander Max 500 EFI DPS	500cc	2013	2015				
Outlander Max 500 EFI XT	500cc	2011	2015				
Outlander Max 500 EFI XT	500cc	2012	2014				
Outlander Max 500 HO EFI	499cc	2007	2010				

ELECTRIC PARTS ATV - UTV

MARCA MAKE	MODELLO MODEL	CC CC	DA FROM	A TO	ALTERNATORE ALTERNATORE	CENTRALINA CDI	GENERATORE GENERATOR
CAN-AM	Outlander Max 500 HO EFI LTD	499cc	2010	2010			
	Outlander Max 500 HO EFI XT	499cc	2007	2010			
	Outlander Max 500 HO EFI XT-P	499cc	2010	2010			
	Outlander Max 650 EFI	650cc	2011	2015			
	Outlander Max 650 EFI DPS	650cc	2013	2014			
	Outlander Max 650 EFI DPS	650cc	2013	2015			
	Outlander Max 650 EFI XT	650cc	2011	2015			
	Outlander Max 650 EFI XT	650cc	2012	2014			
	Outlander Max 650 EFI XT-P	650cc	2010	2012			
	Outlander Max 650 HO EFI	649cc	2007	2010			
	Outlander Max 650 HO EFI XT	649cc	2007	2010			
	Outlander Max 650 HO EFI XT-P	649cc	2010	2010			
	Outlander Max 800 HO EFI	799cc	2007	2010			
	Outlander Max 800 HO EFI LTD	799cc	2007	2010			
	Outlander Max 800 HO EFI XT	799cc	2007	2010			
	Outlander Max 800 HO EFI XT-P	799cc	2010	2010			
	Outlander Max 800R EFI	800cc	2011	2012			
	Outlander Max 800R EFI DPS	800cc	2013	2015			
	Outlander Max 800R EFI LTD	799cc	2012	2012			
	Outlander Max 800R EFI LTD	800cc	2011	2012			
	Outlander Max 800R EFI XT	799cc	2012	2012			
	Outlander Max 800R EFI XT	800cc	2011	2015			
	Outlander Max 800R EFI XT	800cc	2012	2015			
	Outlander Max 800R EFI XT-P	799cc	2012	2012			
	Outlander Max 800R EFI XT-P	800cc	2010	2015			
	Outlander Max 800R EFI XT-P	800cc	2012	2015			
	Rally 200	176cc	2007	2007			
	Renegade 1000	976cc	2012	2015			
	Renegade 1000 EFI X xc	976cc	2012	2012			
	Renegade 1000 X xc	976cc	2013	2015			
	Renegade 500	499cc	2008	2010			
	Renegade 500	500cc	2013	2015			
	Renegade 500 EFI	500cc	2011	2012			
	Renegade 800	799cc	2007	2010			
	Renegade 800 R	800cc	2011	2011			
	Renegade 800 X	799cc	2008	2009			
	Renegade 800 X	800cc	2010	2010			
	Renegade 800 X xc	799cc	2010	2010			
	Renegade 800 X xc	800cc	2011	2011			
	Renegade 800R	800cc	2012	2015			
	Renegade 800R	800cc	2013	2015			
	Renegade 800R		2011	2011			
	Renegade 800R EFI X xc	800cc	2012	2012			
	Renegade 800R X xc	800cc	2013	2015			
	Sarasota 1000	249cc	2004	2005			
Spyder RS (SE5)	998cc	2013	2015				
Spyder RS (SM5)	998cc	2013	2015				
Spyder RT (SE5)	998cc	2010	2013				
Spyder RT (SE5) 990	998cc	2011	2011				
Spyder RT (SE5) 990 Audio/Convenience	990cc	2010	2010				

BOBINE ACCENSIONE IGNITION COILS	REGOLATORI & RADDRIZ- ZATORI REGULATORS & RECTIFIERS	KIT RIPARAZIONE REPAIR KIT	INTERRUTTORI SOLENOIDI SOLENOID SWITCH	MOTORINI AVVIAMENTO STARTER	INGRANAGGI AVVIAMENTO STARTER DRIVES	KIT RIPARAZIONE MOTO- RINI AVVIAMENTO STARTER REPAIR KIT	STATORI STATORS
				18880N			
				18880N			
				18880N			
				18880N			
				18880N			
				18880N			
				18880N			
	S1005N			18880N			
				18880N			
				19584N			
				19584N			
				19584N			
				19584N			
				19495N			
				19584N			
				19495N			
				19495N			
				19575N			
				19575N			
				19575N			
				19578N			
				19578N			
				19578N			
				19578N			
				19578N			
				19578N			
				19578N			
				19578N			
				19575N			
				19575N			
				19575N			
				19578N			
				19578N			
				19572N			
				19575N			
				19575N			
				19572N			
				19572N			
				19575N			
				19575N			
				19575N			
				19575N			
				19575N			
				19575N			
				19572N			
				19572N			
				19578N			
				19578N			
				19575N			
				19578N			

ELECTRIC PARTS
ATV - UTV

MARCA MAKE	MODELLO MODEL	CC CC	DA FROM	A TO	ALTERNATORE ALTERNATORE	CENTRALINA CDI	GENERATORE GENERATOR
CAN-AM	Spyder RT (SM5)	998cc	2010	2013			
	Spyder RT (SM5) 990	998cc	2010	2012			
	Spyder RT (SM5) Audio/Convenience	998cc	2010	2012			
	Spyder RT 990	990cc	2010	2010			
	Spyder RT Limited (SE5)	998cc	2010	2013			
	Spyder RT Limited 990	990cc	2010	2010			
	Spyder ST (SE5)	998cc	2013	2015			
	Spyder ST (SM5)	998cc	2013	2015			
	Spyder ST Limited (SE5)	998cc	2013	2015			
CF MOTO	CF500		2007	2009			
	CF500-2		2011	2012			
	CF500-2A		2011	2012			
	Rancher 500		2011	2013			
	Rancher 600		2011	2013			
	Tracker 800		2013	2013			
	X5 Terralander 500		2011	2013			
	X6 Terralander 625		2011	2013			
	X8 Terralander 800		2012	2013			
	Z6 Terracross 600		2012	2013			
	Z6-EX Terracross 625 EX		2012	2013			
	Z6-EX Terracross 625 EX		2014	2014			
	CUB CADET	7252		1998	2003		
7254			1998	2003			
365L			2000	2002			
5254E			2004	2006			
5254L			2004	2006			
Big Country 4x2 Utility			2003	2005			
GT2521			2004	2004			
LT2180			2003	2004			
M60-KW LC Tank			2004	2006			
M72-KW LC Tank			2005	2006			
Volunteer Diesel			2008	2012			
Z48L			1997	1998			
Z54L			1997	1999			
DAIHATSU	Various Models						
DAYANG	DY100		2005	2008			
	DY110		2010	2010			
	DY90		2008	2008			
E-TON	AXL 90	83cc	2001	2001			
	Beamer R4 (150)	150cc	2007	2009			
	DXL 90	83cc	1999	2001			
	DXL 90U	83cc	1999	2001			
	Thunder 90	88cc	1999	2001			
	TXL 90	83cc	2000	2001			
	Viper 150R	149cc	2005	2011			
	Viper 50	49cc	2002	2004			
	Viper 90	88cc	2002	2007			
	Viper 90R 4-Stroke	88cc	2006	2011			
	Viper 90R Silver Series	88cc	2009	2013			
	Yukon II CXL 150	149cc	2002	2010			

BOBINE ACCENSIONE	REGOLATORI & RADDRIZZATORI	KIT RIPARAZIONE	INTERRUTTORI SOLENOIDI	MOTORINI AVVIAMENTO	INGRANAGGI AVVIAMENTO	KIT RIPARAZIONE MOTORINI AVVIAMENTO	STATORI
IGNITION COILS	REGULATORS & RECTIFIERS	REPAIR KIT	SOLENOID SWITCH	STARTER	STARTER DRIVES	STARTER REPAIR KIT	STATORS
				19572N			
				19575N			
				19575N			
				19575N			
				19575N			
				19575N			
				19575N			
				19575N			
				19572N			
				19572N			
				19575N			
				19575N			
				19572N			
				19575N			
				19578N			
				19578N			
				19572N			
				19575N			
				19575N			
				19572N			
				19575N			
				19572N			
				19578N			
				19572N			
				19575N			
				19575N			
				19572N			
				19578N			
				19578N			
				19572N			
				19572N			
				19572N			
				19572N			
				19572N			
				19572N			
				19572N			
				19575N			
				19575N			
				19577N			
				19572N			
				19572N			
				19578N			
				19578N			
				19572N			
				19578N			
				19575N			
				19578N			
				19589N			
				18644N			
				19572N			
				18644N			

ELECTRIC PARTS
ATV - UTV

ELECTRIC PARTS ATV - UTV

MARCA MAKE	MODELLO MODEL	CC CC	DA FROM	A TO	ALTERNATORE ALTERNATORE	CENTRALINA CDI	GENERATORE GENERATOR
E-TON EAGLE	YXL 150	150cc	2001	2002			
	200 GY						
	200 HS						
	200 ST						
	200 ST-7						
	200 STV						
	250 ST						
	250 ST-5						
	250 ST-6						
	250 Utility						
	Apache 110 Big Wheel						
	Apache 110 Widetrack						
	AR 125						
	Avenger 200 Sport RS						
	Avenger 250 Sport						
	B08 150						
	BC 110						
	CA-7 110						
	Capri 150						
	Carino 150						
	Eagle 110 BI						
	Eagle 110 CA-8						
	Eagle 110 FA						
	Eagle 110 FE						
	Eagle 125 CD-7						
	Eagle 150						
	Eagle 200						
	Eagle 250						
	Eagle 90 FA						
	Enduro 200						
	Euro 150						
	FA 70						
	FAC 110						
	FAC 90						
	FAE 110						
	FAE 70						
	FAE 90						
	FS 706						
	GK150						
	GSR 150						
	Hanma 110						
	Hanwei 110						
	Hanwei 150						
	Hawk 110 Youth						
	Hellkat 250-R						
	Kazuma 250						
	Milano 150						
	Mini Utility 110						
	Mini Utility BI						
	Racer 150						

BOBINE ACCENSIONE	REGOLATORI & RADDRIZZATORI	KIT RIPARAZIONE	INTERRUTTORI SOLENOIDI	MOTORINI AVVIAMENTO	INGRANAGGI AVVIAMENTO	KIT RIPARAZIONE MOTORINI AVVIAMENTO	STATORI
IGNITION COILS	REGULATORS & RECTIFIERS	REPAIR KIT	SOLENOID SWITCH	STARTER	STARTER DRIVES	STARTER REPAIR KIT	STATORS
							27-7019
				18644N			27-7019
				18644N			
				19572N			
							27-7019
				18644N			
				18644N			
				18644N			
				19572N			
				19572N			
				18365N			
				19597N			
				19597N			
				19597N			
				19597N			
				19597N			
				19597N			
				19597N			
				19597N			
				19597N			
				19597N			
				19597N			
				19597N			
				19597N			
				19597N			
				19597N			
				19597N			
				19597N			
				19572N			
				19572N			
				19572N			
				19572N			
				19572N			
				19572N			
				19572N			
				19572N			
				19572N			
				19572N			
				19575N			
				19577N			
				19574N			
				19577N			
				19575N			
				19575N			
				19574N			
				19577N			
				19575N			
				19572N			
				19575N			
				19575N			
				19575N			
				19575N			
				19575N			
				19576N			
				19576N			
				19575N			

ELECTRIC PARTS ATV - UTV

MARCA MAKE	MODELLO MODEL	CC CC	DA FROM	A TO	ALTERNATORE ALTERNATORE	CENTRALINA CDI	GENERATORE GENERATOR
EAGLE	Reaction 110						
	Reaction 150 Auto						
	Reaction 200 WC						
	Rugged 150						
	Scout 125						
	Sport Utility 125 HW						
	Sport Utility 150 HW						
	Sport Utility 200 HW						
	Sport Utility 250 HW						
	Sporty 150						
	ST 150						
	STI 150						
	T-5 150						
	T-8 150						
	Tianke 150						
	Tomahawk 110 SE						
	Tonga 110 Big Wheel						
	Touring 250						
	Touring A 150						
	Touring B 150						
	Trail King 250 Chain						
	Trail King 250 Shaft						
	Trail Master 150						
	Trail Master 200						
	Wildfire 110						
Wildkat 250S							
Woodsman 300XL			2005	2008			
EZ-GO	BC-960GX		1994	2008			15423N
	Cargo Shuttle		1994	2008			15423N
	Grand Oasis		1994	2008			15423N
	GXI-875		1994	2008			15423N
	GXI-875P		1994	2008			15423N
	GXT-875		1994	2008			15423N
	GXT-875P		1994	2008			15423N
	Industrial 800		1999	2008			15423N
	Medalist		1993	2008			15423N
	MG2 4 Caddy		1998	2008			15423N
	MG2 Fleet		1998	2008			15423N
	MG2 Freedom		1998	2008			15423N
	MG2 Freedom HP		1998	2008			15423N
	Oasis		1996	2008			15423N
	PC-952GX		1994	2008			15423N
	PC-954GX		1994	2008			15423N
	PC-956GX		1994	2008			15423N
	Shuttle 6		1994	2008			15423N
	TXT 4 Caddy		1998	2008			15423N
	TXT Fleet		1998	2008			15423N
	TXT Freedom		1998	2008			15423N
	TXT Freedom HP		1998	2008			15423N
	TXT Models			1980	1993		

BOBINE ACCENSIONE	REGOLATORI & RADDRIZZATORI	KIT RIPARAZIONE	INTERRUTTORI SOLENOIDI	MOTORINI AVVIAMENTO	INGRANAGGI AVVIAMENTO	KIT RIPARAZIONE MOTORINI AVVIAMENTO	STATORI
IGNITION COILS	REGULATORS & RECTIFIERS	REPAIR KIT	SOLENOID SWITCH	STARTER	STARTER DRIVES	STARTER REPAIR KIT	STATORS
CPS27							
CPS27							
			67-748				
CPS27							
			67-748				
			67-748				
CPS27			67-748				
CPS27			67-748	18603N			
CPS27			67-748	18603N			
CPS27							
			67-748	18603N			
CPS27							
			67-748				
CPS27							
			67-748				
				18341N			
						79-85112	
				18337N			
		79-85107					
CPS27							
			67-748				
				18341N		79-85112	
				18337N		79-85101	
			67-748				
			67-748				
			67-748				
CPS27							
CPS27							
		79-85107					
						79-85101	
						79-85101	
						79-85101	
		79-85107					
		79-85107					
						79-85101	
CPS27							
						79-85101	
						79-85101	
						79-85101	
						79-85101	
CPS27							
CPS27							
CPS27							
CPS27							
CPS27							
CPS27							
CPS27							

ELECTRIC PARTS
ATV - UTV

ELECTRIC PARTS ATV - UTV

MARCA MAKE	MODELLO MODEL	CC CC	DA FROM	A TO	ALTERNATORE ALTERNATORE	CENTRALINA CDI	GENERATORE GENERATOR
EZ-GO	Workhorse 1200		1994	2008			15423N
	Workhorse 1200 LX		1994	2008			15423N
	Workhorse 800		1994	2008			15423N
	Workhorse 800 LX		1994	2008			15423N
	Workhorse ST350		1994	2008			15423N
FLEXI-COIL GMI	Various Models						
	GMI 101		2004	2008			
	GMI 102		2004	2008			
	GMI 102P		2004	2008			
	GMI 103		2004	2008			
	GMI 104		2004	2008			
	GMI 106		2004	2008			
	GMI 106I		2004	2008			
	GMI 107		2004	2008			
	GMI 107XP		2004	2008			
	GMI 108		2004	2008			
	GMI 109		2004	2008			
	GMI 110		2005	2008			
	GMI 111		2004	2008			
	GMI 301		2004	2008			
	GMI 304		2004	2008			
	GMI 306		2004	2008			
	GMI 307		2004	2008			
	GMI 401		2004	2008			
	GMI 403		2004	2008			
GMI 404		2004	2008				
GMI 405		2004	2008				
GMI 406		2004	2008				
GO SCOOT	Baby Falcon 110						
	Cougar 250						
	Dingo 150						
	Dingo 250						
	Falcon 110						
	Falcon 110 Deluxe						
	Falcon 150						
	Falcon 250						
	Jaguar 110						
	Jaguar 150						
	Kat 150						
	Lacoste 110						
	Lacoste 150						
	Meercat 50						
	Meercat 50 Deluxe						
HONDA	Panda 110						
	ATC110	105cc	1979	1985			
	ATC110		1981	1984			
	ATC125M	124cc	1984	1987			
	ATC125M		1984	1984			
	ATC185S	180cc	1981	1983			
ATC185S		1979	1983				

BOBINE ACCENSIONE IGNITION COILS	REGOLATORI & RADDRIZ- ZATORI REGULATORS & RECTIFIERS	KIT RIPARAZIONE REPAIR KIT	INTERRUTTORI SOLENOIDI SOLENOID SWITCH	MOTORINI AVVIAMENTO STARTER	INGRANAGGI AVVIAMENTO STARTER DRIVES	KIT RIPARAZIONE MOTO- RINI AVVIAMENTO STARTER REPAIR KIT	STATORI STATORS
						79-85101	
CPS27			67-748				
			67-748				
			67-748	18338N		79-85108	
CPS27						79-85101	
CPS27							
CPS27							
CPS27							
CPS27							
CPS27							
CPS27							
CPS27							
CPS27							
CPS27							
CPS27							
CPS27							
CPS27							
CPS27							
CPS27							
		79-85107					
CPS27							
CPS27							
				18921N			
				18921N			
				18329N			
				18603N			
				18605N		79-85108	
				18605N		79-85108	
				18341N			
						79-85112	
				18337N			
		79-85107					
	HN1016N						
	HN1016N						
		79-85107		18336N			
			67-783				
	HN1016N						
		79-85107		18336N			
				19642N			
				18336N			
	HN1016N						
		79-85107					
			67-783				
				19642N			
				18336N			

ELECTRIC PARTS
ATV - UTV

ELECTRIC PARTS ATV - UTV

MARCA MAKE	MODELLO MODEL	CC CC	DA FROM	A TO	ALTERNATORE ALTERNATORE	CENTRALINA CDI	GENERATORE GENERATOR
HONDA	ATC185S		1980	1980			
	ATC200	192cc	1981	1983			
	ATC200E	192cc	1982	1983			
	ATC200ES	192cc	1984	1984			
	ATC200M	192cc	1984	1985			
	ATC200M		1984	1984			
	ATC200S	192cc	1984	1986			
	ATC200S		1984	1984			
	ATC200X	192cc	1983	1987			
	ATC200X		1983	1985			
	ATC250ES Big Red	246cc	1985	1986			
	ATC250ES Big Red	246cc	1985	1987			
	ATC250ES Big Red	246cc	1986	1987		HNC1036	
	ATC250ES Big Red	246cc	1987	1987			
	ATC250ES Big Red		1988	1988			
	ATC250R	248cc	1981	1986			
	ATC250R	248cc	1986	1986		HNC1037	
	ATC250R		1981	1984			
	ATC250SX	246cc	1985	1986			
	ATC250SX	246cc	1986	1987		HNC1036	
	ATC250SX	246cc	1987	1987			
	ATC350X	350cc	1985	1986			
	ATC70	72cc	1978	1985			
	ATC90	89cc	1976	1978			
	CB125TD		1982	1987			
	CB250RS		1980	1983			
	CB400F CB-1	395cc	1989	1990			
	CB550SC Nighthawk	544cc	1983	1983			
	CB650SC Nighthawk	655cc	1983	1985			
	CBR1000F Hurricane	998cc	1987	1991			
	CBR600F	598cc	1990	1990			
	CBR600F		1987	1989			
	CH250 Elite	249cc	1985	1988			
	CL250SC		1981	1984			
	CMX450C Rebel	447cc	1986	1987			
	CN250 Fusion		1986	1988			
	CN250 Helix	244cc	1986	1987			
	CN250 Spazio		1986	1988			
	CR125R		1999	1999			
	CR250R		1981	1999			
	CR450R		1981	1981			
	CR480R		1982	1983			
	CR80R		1980	1986			
	CRM50R		1992	1996			
	CRM75R		1989	1994			
	CX650T Turbo	673cc	1983	1983			
	FL250 Odyssey	248cc	1977	1984			
FL250 Odyssey		1981	1984				
FL350R Odyssey	329cc	1985	1985				
FL400R Pilot	397cc	1989	1990				

BOBINE ACCENSIONE IGNITION COILS	REGOLATORI & RADDRIZ- ZATORI REGULATORS & RECTIFIERS	KIT RIPARAZIONE REPAIR KIT	INTERRUTTORI SOLENOIDI SOLENOID SWITCH	MOTORINI AVVIAMENTO STARTER	INGRANAGGI AVVIAMENTO STARTER DRIVES	KIT RIPARAZIONE MOTO- RINI AVVIAMENTO STARTER REPAIR KIT	STATORI STATORS
		79-85107					
	HN1024N						
		79-85107		18337N			27-7039
	HN1019						
						79-85108	
	H1059N						
				18329N			27-7035
	HN1024N						
		79-85107		18337N			27-7039
	HN1019						
						79-85108	27-7035
				18335N			
						79-85101	
				18339N			
				18339N		79-85101	
	HN1015N						
				18607N			
	HN1015N						
				18607N			
	HN1015N						
				18607N			
	HN1015N						
				18607N			
				18608N			
	HN1016N						
				18855N			
	H1049N						
				18683N			
	H1049N						
				18683N			
		79-85107					
	HN1015N			18638N			
				18855N			
				18921N			
				18921N			
	HN1023			18921N			27-7074
				18921N			
	HN1023			18921N			27-7074
				18921N			
				18921N			
	HN1023			18921N			
	HN1023			18921N			27-7074
	HN1023			18921N			27-7074
	HN1023			18921N			27-7074
				18921N			

ELECTRIC PARTS ATV - UTV

MARCA MAKE	MODELLO MODEL	CC CC	DA FROM	A TO	ALTERNATORE ALTERNATORE	CENTRALINA CDI	GENERATORE GENERATOR
HONDA	FT500 Ascot	497cc	1982	1983			
	MB5		1982	1982			
	MBX50		1983	1986			
	MBX80		1983	1986			
	MT5 / MT50		1980	1993			
	MTX125		1983	1995			
	MTX200		1983	1985			
	MTX50		1982	1985			
	MUV700 Big Red	675cc	2009	2013			
	NB50 Aero		1984	1984			
	NC50		1982	1983			
	NH125 Aero		1983	1984			
	NH80 Mascot		1983	1984			
	NH80 Vision		1983	1984			
	NU50		1982	1983			
	NV50		1984	1984			
	NX50		1980	1982			
	NX650	644cc	1988	1989			
	PX50		1981	1986			
	PXR50		1984	1987			
	SXS500M			2015	2015		
	SXS500M2			2015	2015		
	SXS700M2 Pioneer 700	675cc	2014	2014			
	SXS700M2 Pioneer 700			2015	2015		
	SXS700M4 Pioneer 700-4	675cc	2014	2014			
	SXS700M4 Pioneer 700-4			2015	2015		
	TR300X	282cc	2009	2009			
	TRX200	--L 198cc -cid	1984	1984			
	TRX200 FourTrax	198cc	1990	1991			HNC1026
	TRX200D FourTrax Type II	198cc	1991	1997			HNC1026
	TRX250	248cc	1985	1986			
	TRX250	248cc	1985	1987			HNC1036
	TRX250	248cc	1987	1987			
	TRX250	248cc	1987	2001			
	TRX250	248cc	1997	2001			
	TRX250	248cc	1998	2001			HNC1023
	TRX250EX Sportrax	229cc	2001	2005			
	TRX250EX Sportrax	229cc	2001	2008			
	TRX250R	249cc	1986	1987			HNC1037
	TRX250R	249cc	1988	1989			HNC1038
	TRX250R		2005	2016			
	TRX250TE FourTrax Recon ES	229cc	2002	2004			
	TRX250TE FourTrax Recon ES	229cc	2002	2007			
TRX250TE FourTrax Recon ES	229cc	2008	2014				
TRX250TM FourTrax Recon	229cc	1997	2007				
TRX250TM FourTrax Recon	229cc	2002	2004				
TRX250TM FourTrax Recon	229cc	2002	2007				
TRX250TM FourTrax Recon	229cc	2005	2016				
TRX250TM FourTrax Recon	229cc	2008	2014				
TRX250X	229cc	2009	2014				

BOBINE ACCENSIONE IGNITION COILS	REGOLATORI & RADDRIZ- ZATORI REGULATORS & RECTIFIERS	KIT RIPARAZIONE REPAIR KIT	INTERRUTTORI SOLENOIDI SOLENOID SWITCH	MOTORINI AVVIAMENTO STARTER	INGRANAGGI AVVIAMENTO STARTER DRIVES	KIT RIPARAZIONE MOTO- RINI AVVIAMENTO STARTER REPAIR KIT	STATORI STATORS
	HN1023			18921N			27-7074
				18921N			
				18922N			
				18922N			
	HN1015N						
				18638N			
				18638N			
	HN1015N						
	HN1015N						
		79-85107					
				18666N			
		79-85107					
							27-7072
				18921N			
							27-7075
				18638N			
							27-7075
				18638N			
							27-7073
				18921N			
				18921N			
				18921N			
		79-85107		18666N			
							27-7072
				18638N			
							27-7075
				18638N			
							27-7073
				18921N			
				18921N			
				18921N			
				18666N			
							27-7072
				18666N			
		79-85107					
				18638N			
				18638N			27-7075
				18921N			27-7073
				18638N			
							27-7075
				18638N			
				18921N			27-7073
				18638N			
				19650N			
				19081N			
				19081N			
				19081N			
						79-85101	

ELECTRIC PARTS ATV - UTV

MARCA MAKE	MODELLO MODEL	CC CC	DA FROM	A TO	ALTERNATORE ALTERNATORE	CENTRALINA CDI	GENERATORE GENERATOR
HONDA	TRX250X	229cc	2009	2016			
	TRX300 FourTrax	282cc	1988	1992			
	TRX300 FourTrax	282cc	1988	2000			
	TRX300 FourTrax	282cc	1989	1992		HNC1033	
	TRX300 FourTrax	282cc	1993	2000			
	TRX300 FourTrax	282cc	1994	1997		HNC1024	
	TRX300EX Sportrax	282cc	1993	1998			
	TRX300EX Sportrax	282cc	1993	2004			
	TRX300EX Sportrax	282cc	1993	2006		HNC1027	
	TRX300EX Sportrax	282cc	1993	2008			
	TRX300FW FourTrax 4x4	282cc	1988	1992			
	TRX300FW FourTrax 4x4	282cc	1988	2000			
	TRX300FW FourTrax 4x4	282cc	1990	1993		HNC1033	
	TRX300FW FourTrax 4x4	282cc	1993	2000			
	TRX300FW FourTrax 4x4	282cc	1994	1997		HNC1024	
	TRX300X	282cc	2009	2009			
	TRX350	329cc	1986	1986			
	TRX350	329cc	1986	1987			
	TRX350	329cc	1987	1989			
	TRX350D	329cc	1987	1989			
	TRX350FE FourTrax Rancher 4x4 ES	329cc	2000	2003			
	TRX350FE FourTrax Rancher 4x4 ES	329cc	2000	2006			
	TRX350FM FourTrax Rancher 4X4	329cc	2000	2003			
	TRX350FM FourTrax Rancher 4X4	329cc	2000	2006			
	TRX350TE FourTrax Rancher ES	329cc	2000	2003			
	TRX350TE FourTrax Rancher ES	329cc	2000	2006			
	TRX350TM FourTrax Rancher	329cc	2000	2003			
	TRX350TM FourTrax Rancher	329cc	2000	2006			
	TRX400EX Sportrax	397cc	1999	2004			HNC1029
	TRX400EX Sportrax	397cc	2000	2004			
	TRX400EX Sportrax	397cc	2005	2008			HNC1039
	TRX400FA FourTrax Rancher AT	395cc	2004	2006			
	TRX400FA FourTrax Rancher AT	395cc	2004	2007			
	TRX400FGA FourTrax Rancher AT GPScape	395cc	2004	2006			
	TRX400FGA FourTrax Rancher AT GPScape	395cc	2004	2007			
	TRX400FW Foreman 4x4	395cc	1995	2001			
	TRX400FW Foreman 4x4	395cc	1995	2003			HNC1031
	TRX400X	397cc	2009	2014			HNC1039
	TRX420FA Rancher AT	420cc	2009	2013			
	TRX420FA Rancher AT	420cc	2009	2014			
	TRX420FA1 FourTrax Rancher 4x4 Auto DCT	420cc	2014	2014			
	TRX420FA1 FourTrax Rancher 4x4 Auto DCT	420cc	2014	2016			
	TRX420FA2 FourTrax Rancher 4x4 Auto DCT with EPS	420cc	2014	2014			
	TRX420FE FourTrax Rancher 4X4 ES	420cc	2007	2013			
	TRX420FE1 FourTrax Rancher 4x4 ES	420cc	2014	2016			
	TRX420FM FourTrax Rancher 4X4	420cc	2007	2013			
	TRX420FM1 FourTrax Rancher 4x4	420cc	2014	2016			
	TRX420FM2 FourTrax Rancher 4x4 with EPS	420cc	2014	2016			
	TRX420FPA Rancher AT 4x4 w/ Power Steering	420cc	2009	2014			
	TRX420FPE Rancher ES 4x4 w/ Power Steering	420cc	2009	2013			

BOBINE ACCENSIONE	REGOLATORI & RADDRIZZATORI	KIT RIPARAZIONE	INTERRUTTORI SOLENOIDI	MOTORINI AVVIAMENTO	INGRANAGGI AVVIAMENTO	KIT RIPARAZIONE MOTORINI AVVIAMENTO	STATORI
IGNITION COILS	REGULATORS & RECTIFIERS	REPAIR KIT	SOLENOID SWITCH	STARTER	STARTER DRIVES	STARTER REPAIR KIT	STATORS
						79-85101	
						79-85101	
						79-85101	
						79-85101	
						79-85101	
						79-85101	
	HN1015N						
	HN1015N						
	HN1015N						
	HN1015N						
						79-85108	
CPS27							
CPS27							
CPS27							
CPS27							
						79-85101	
CPS27							
CPS27							
CPS27							
CPS27							
CPS27							
CPS27							
		79-85107					
				19575N			
				19576N			
				19575N			
				19574N			
				19578N			
				19576N			
				18817N			
				18817N			
				18817N			
				18817N			
CPS27							
CPS27							
CPS27							
CPS27							
			67-748				
			67-748				
			67-748				
			67-748				
			67-748				
			67-748				
			67-748				
			67-748				
			67-748				
			67-748				
						79-85101	
						79-85101	
			67-748				

ELECTRIC PARTS
ATV - UTV

ELECTRIC PARTS ATV - UTV

MARCA MAKE	MODELLO MODEL	CC CC	DA FROM	A TO	ALTERNATORE ALTERNATORE	CENTRALINA CDI	GENERATORE GENERATOR
HONDA	TRX420FPM Rancher 4x4 w/ Power Steering	420cc	2009	2013			
	TRX420TE FourTrax Rancher ES	420cc	2007	2013			
	TRX420TE1 FourTrax Rancher ES	420cc	2014	2016			
	TRX420TM FourTrax Rancher	420cc	2007	2013			
	TRX420TM1 FourTrax Rancher	420cc	2014	2016			
	TRX450ER Electric Start	432cc	2012	2012			
	TRX450ER Electric Start	450cc	2006	2014			
	TRX450ES		1998	2001			
	TRX450FE FourTrax Foreman ES	433cc	1998	2004			
	TRX450FM FourTrax Foreman S	433cc	1998	2004			
	TRX450R	450cc	2004	2005		HNC1034	
	TRX450R	450cc	2006	2009		HNC1043	
	TRX450S		1998	2001			
	TRX450S Fourtrax Foreman S		1998	2001			
	TRX500FA FourTrax Foreman Rubicon	499cc	2001	2014			
	TRX500FA FourTrax Foreman Rubicon	499cc	2004	2012			
	TRX500FA FourTrax Foreman Rubicon	499cc	2005	2014			
	TRX500FA FourTrax Foreman Rubicon		2015	2016			
	TRX500FE FourTrax Foreman 4x4 ES	475cc	2009	2011			
	TRX500FE FourTrax Foreman 4x4 ES	475cc	2011	2011			
	TRX500FE FourTrax Foreman 4x4 ES	475cc	2012	2013			
	TRX500FE FourTrax Foreman 4x4 ES	475cc	2012	2016			
	TRX500FE FourTrax Foreman 4x4 ES	499cc	2005	2008			
	TRX500FE FourTrax Foreman 4x4 ES	499cc	2005	2009			
	TRX500FE1 FourTrax Foreman 4x4 ES	475cc	2014	2016			
	TRX500FE2 FourTrax Foreman 4x4 ES with EPS	475cc	2014	2014			
	TRX500FGA FourTrax Foreman Rubicon GPScape	499cc	2004	2008			
	TRX500FGA FourTrax Foreman Rubicon GPScape	499cc	2005	2008			
	TRX500FM FourTrax Foreman 4x4	475cc	2009	2011			
	TRX500FM FourTrax Foreman 4x4	475cc	2011	2011			
	TRX500FM FourTrax Foreman 4x4	475cc	2012	2013			
	TRX500FM FourTrax Foreman 4x4	475cc	2012	2016			
	TRX500FM FourTrax Foreman 4x4	499cc	2005	2009			
	TRX500FM1 FourTrax Foreman 4x4	475cc	2014	2016			
	TRX500FM2 FourTrax Foreman 4x4 with EPS	475cc	2014	2016			
	TRX500FPA FourTrax Foreman 4x4 AT w/ Power Steering	499cc	2009	2012			
	TRX500FPA FourTrax Foreman Rubicon with EPS	499cc	2009	2009			
	TRX500FPA FourTrax Foreman Rubicon with EPS	499cc	2011	2014			
	TRX500FPA FourTrax Rincon GPS		2009	2014			
	TRX500FPE FourTrax Foreman 4x4 ES w/ Power Steering	475cc	2011	2011			
	TRX500FPE FourTrax Foreman 4x4 ES w/ Power Steering	475cc	2012	2013			
	TRX500FPE FourTrax Foreman 4x4 ES w/ Power Steering	499cc	2007	2009			
	TRX500FPM FourTrax Foreman 4x4 w/ Power Steering	475cc	2009	2011			
	TRX500FPM FourTrax Foreman 4x4 w/ Power Steering	475cc	2011	2011			
	TRX500FPM FourTrax Foreman 4x4 w/ Power Steering	475cc	2012	2013			
	TRX500FPM FourTrax Foreman 4x4 w/ Power Steering	499cc	2008	2009			
	TRX500TM FourTrax Foreman	499cc	2005	2006			
	TRX650FA FourTrax Rincon	649cc	2003	2005			
	TRX650FGA FourTrax Rincon GPScape	649cc	2004	2005			
	TRX680FA FourTrax Rincon	675cc	2006	2016			

BOBINE ACCENSIONE	REGOLATORI & RADDRIZZATORI	KIT RIPARAZIONE	INTERRUTTORI SOLENOIDI	MOTORINI AVVIAMENTO	INGRANAGGI AVVIAMENTO	KIT RIPARAZIONE MOTORINI AVVIAMENTO	STATORI
IGNITION COILS	REGULATORS & RECTIFIERS	REPAIR KIT	SOLENOID SWITCH	STARTER	STARTER DRIVES	STARTER REPAIR KIT	STATORS
			67-748				
CPS27							
CPS27							
CPS27							
CPS27							
			67-748	18701N			
			67-748	18701N			
			67-748	18718N			
				19032N			
			67-748				
				18719N			
				18332N		79-85110	
				18816N			
CPS27							
			67-748				
			67-748				
			67-748				
			67-748				
			67-748	18693N			
			67-748	18716N			
				18716N			
			67-748				
				18716N			
	KW1027N						
			67-748	18701N			
				18701N			
			67-748				
		79-85107	67-748	18702N			
			67-748				
			67-748				
	KW1026N		67-748				
	KW1026N						
			67-748				
	KW1026N						
CPS27							
				18718N			
				18718N			
				18719N			
	KW1033N			18719N			
			67-748				
			67-748	18719N			
	KW1033N						
	KW1033N		67-748	18719N			
				18719N			
			67-748	18719N			
	KW1033N		67-748	18719N			
				18719N			
			67-748	18719N			
			67-748	18719N			
			67-748				
	KW1033N						

ELECTRIC PARTS ATV - UTV

MARCA	MODELLO	CC	DA	A	ALTERNATORE	CENTRALINA	GENERATORE	
MAKE	MODEL	CC	FROM	TO	ALTERNATORE	CDI	GENERATOR	
HONDA	TRX680FGA FourTrax Rincon GPScape	675cc	2006	2009				
	TRX700XX	686cc	2008	2009				
	TRX90 Sportrax	86cc	1993	2005		HNC1025		
	TRX90 Sportrax	86cc	2006	2008				
	TRX90EX Sportrax	86cc	2007	2008				
	TRX90X	86cc	2009	2014				
	VF500C V30 Magna	497cc	1984	1985				
	VF500F Interceptor	497cc	1984	1986				
	VT1100C Shadow	1099cc	1985	1994				
	VT500C Shadow	491cc	1983	1986				
	VT500FT Ascot	491cc	1983	1984				
	VT700C Shadow	694cc	1984	1987				
	VT750C Shadow	745cc	1983	1983				
	VT750C Shadow Aero	745cc	2004	2009				
	VT750C2 Shadow Spirit	745cc	2007	2009				
	VT750C2F			2007	2008			
	VT750CA			2004	2009			
	VTR250 Interceptor	249cc	1988	1990				
	XL125S			1979	1983			
	XL185S			1979	1983			
	XL200R			1983	1983			
	XL250R			1982	1983			
	XL600V Transalp	591cc	1989	1990				
	XR185			1979	1979			
	XR200			1980	1983			
	XR200R			1981	1983			
	XR250R			1981	1983			
	XR350R			1983	1984			
	XR500R			1981	1982			
	XR650L	644cc	1993	2016				
	HUSQVARNA	HUV 4421 DXL		2006	2010	12650N		
	ISEKI	TG5390		2005	2015	12650N		
JACKEL	110 ATV							
	50R ATV							
JETMOTO	ATV 125							
	ATV 150							
	ATV 200							
	ATV 50							
JOHN DEERE	285	2 Cyl. 0.58L 585cc 36cid	1987	1992				
	320	2 Cyl. 0.58L 585cc 36cid	1992	1994				
	345	2 Cyl. 0.58L 585cc 36cid	1994	2000				
	345		2001	2006				
	777	2 Cyl. 0.75L 745cc 45cid	2003	2003				
	797	2 Cyl. 0.75L 745cc 45cid	2003	2003				
	2243	2 Cyl. 0.58L 585cc 36cid	1991	1998				
	AMT622 Transporter		1988	1990				
	AMT626 Transporter		1990	1992				
	Bunker & Field Rake 1200							
	Bunker & Field Rake 1200 Hydro							
	Bunker & Field Rake 1200A							

BOBINE ACCENSIONE	REGOLATORI & RADDRIZZATORI	KIT RIPARAZIONE	INTERRUTTORI SOLENOIDI	MOTORINI AVVIAMENTO	INGRANAGGI AVVIAMENTO	KIT RIPARAZIONE MOTORINI AVVIAMENTO	STATORI
IGNITION COILS	REGULATORS & RECTIFIERS	REPAIR KIT	SOLENOID SWITCH	STARTER	STARTER DRIVES	STARTER REPAIR KIT	STATORS
				18719N			
			67-748				
	KW1033N			18719N			
				18719N			
				18719N			
				18719N			
			67-748	18719N			
			67-748	18719N			
				18719N			
			67-748	18719N			
				18719N			
			67-748	18719N			
			67-748	18719N			
			67-748	18719N			
			67-748	18719N			
			67-748	18701N			
			67-748	18701N			
				18717N			
			67-748				
				19058N			
				18717N			
			67-748				
				19058N			
		79-85107	67-748	18702N			
		79-85107	67-748	18702N			
			67-748	18719N			
	KW1033N		67-748	18719N			
			67-748	18719N			
			67-748	18719N			
			67-748	18719N			
				18719N			
	KW1033N			18719N			
			67-748				
						79-85101	
						79-85101	
						79-85101	
		79-85107					
						79-85101	
						79-85101	
						79-85101	
						79-85101	
						79-85101	
	KW1026N						
	KW1026N						
	KW1026N						
	KW1026N						
	KW1026N						
	KW1026N						
						79-85101	
						79-85101	

ELECTRIC PARTS
ATV - UTV

ELECTRIC PARTS ATV - UTV

MARCA MAKE	MODELLO MODEL	CC CC	DA FROM	A TO	ALTERNATORE ALTERNATORE	CENTRALINA CDI	GENERATORE GENERATOR	
JOHN DEERE	F725	2 Cyl. 0.62L 617cc 38cid	1992	1997				
	G5500KE Generator							
	Gator 4 x 2							
	Gator CS Compact Series							
	Gator CX Compact Series							
	Gator TX Turf						15420N	
	Gator XUV 550	570cc	2012	2015				
	Gator XUV 550 S4	570cc	2012	2015				
	Gator XUV 825i 4x4	812cc	2011	2013	14882N			
	Gator XUV 825i 4x4 Power Steering	812cc	2013	2013				
	Gator XUV 825i 4x4 S4	812cc	2013	2013				
	GX345	2 Cyl. 0.58L 585cc 36cid	2003	2005				
	LT170		2002	2002				
	LX178	2 Cyl. 0.44L 437cc 27cid	1993	1998				
	LX188	2 Cyl. 0.44L 437cc 27cid	1992	1998				
	LX279	2 Cyl. 0.44L 437cc 27cid	1998	2002				
	LX289	2 Cyl. 0.49L 494cc 30cid	2003	2005				
	SST16	2 Cyl. 0.48L 479cc 29cid	2000	2005				
	SST18	2 Cyl. 0.57L 570cc 35cid	2000	2005				
	Trail Buck 500	500cc	2004	2005				
	Trail Buck 650	650cc	2004	2005				
	Trail Buck 650 EX	650cc	2004	2005				
	Trail Buck 650 EXT	650cc	2004	2005				
	Trail Gator 4 x 2							
	X475		2002	2005				
	X485		2002	2005				
	X485 AWS	2 Cyl. 0.75L 745cc 45cid	2003	2005				
	X575 4WD	2 Cyl. 0.75L 745cc 45cid	2003	2005				
	X585		2002	2006				
	X585 4WD	2 Cyl. 0.75L 745cc 45cid	2003	2005				
	X700	2 Cyl. 0.75L 745cc 45cid	2006	2009				
	X720		2006	2012				
	X720SE		2006	2012				
	X724		2006	2012				
	X728		2006	2012				
	X728SE		2006	2012				
	X729		2006	2012				
	KAWASAKI	AE50		1981	1982			
		AE80		1981	1984			
		AR50		1981	1994			
AR80			1981	1990				
EN450A 454 LTD		454cc	1985	1990				
EN500 Vulcan 500		499cc	1990	1996				
EN500C Vulcan 500 LTD		499cc	1996	2009				
EX250F Ninja 250R		249cc	1986	2012				
EX500 GPZ 500			1987	1993				
EX500 Ninja 500		498cc	1994	1996				
EX500 Ninja 500R		498cc	1997	2009				
EX650 Ninja 650		649cc	2013	2015				
EX650 Ninja 650 ABS		649cc	2013	2015				

BOBINE ACCENSIONE	REGOLATORI & RADDRIZZATORI	KIT RIPARAZIONE	INTERRUTTORI SOLENOIDI	MOTORINI AVVIAMENTO	INGRANAGGI AVVIAMENTO	KIT RIPARAZIONE MOTORINI AVVIAMENTO	STATORI
IGNITION COILS	REGULATORS & RECTIFIERS	REPAIR KIT	SOLENOID SWITCH	STARTER	STARTER DRIVES	STARTER REPAIR KIT	STATORS
						79-85101	
						79-85101	
						79-85101	
						79-85101	
	KW1026N						
	KW1026N						
	KW1026N						
	KW1026N						
			67-748				
	KW1027N						
	KW1027N						
	KW1027N						
						79-85101	
	KW1027N						
						79-85101	
						79-85101	
						79-85101	
	KW1027N						
	KW1027N						
						79-85101	
	KW1027N						
		79-85107				79-85112	
	KW1027N						
		79-85107				79-85112	
						79-85101	
						79-85101	
						79-85101	
						79-85101	
	KW1027N						
	KW1027N						
						79-85108	
	KW1027N						
	KW1027N						
						79-85112	
						79-85108	
						79-85112	
						79-85112	
						79-85112	
						79-85112	
						79-85112	
						79-85112	
						79-85112	
					19575N		
					19577N		
					19572N		
					19577N		
					19575N		
					19572N		
					19577N		
					19575N		

ELECTRIC PARTS
ATV - UTV

ELECTRIC PARTS ATV - UTV

MARCA MAKE	MODELLO MODEL	CC CC	DA FROM	A TO	ALTERNATORE ALTERNATORE	CENTRALINA CDI	GENERATORE GENERATOR	
KAWASAKI	EX650 Ninja 650R	649cc	2006	2011				
	FB460V							
	FD440V							
	FD501V							
	FD590V							
	FD611V							
	FD671D							
	FD711D							
	FD750D							
	FD791D							
	FD795D							
	FE250D							
	FE290D							
	FE350D							
	FE400D							
	GE4000A							
	GE4500A							
	GE5000AS							
	JF650 X2		650cc	1986	1995			
	JF650 X2			1987	1987			
	KAF300 Mule 500		--L 286cc -cid	1991	1995			
	KAF300 Mule 520		--L 286cc -cid	2000	2001			
	KAF300 Mule 550		--L 286cc -cid	1997	2004			
	KAF400 Mule 600		401cc	2005	2015			
	KAF400 Mule 610 4x4		401cc	2005	2015			
	KAF400 Mule 610 4x4 XC		401cc	2010	2015			
	KAF400 Mule 610 4x4 XC SE		401cc	2014	2015			
	KAF450 Mule 1000		450cc	1988	1988			
	KAF540 Mule 2010		540cc	1990	1990			
	KAF540 Mule 2020		540cc	1990	1990			
	KAF540 Mule 2030		540cc	1991	1991			
	KAF620 Mule 2500		617cc	1995	2000			
	KAF620 Mule 2500		620cc	1994	1994			
	KAF620 Mule 2510 4x4		617cc	1993	2000			
	KAF620 Mule 2520		617cc	1993	2000			
	KAF620 Mule 3000		617cc	2001	2008			
	KAF620 Mule 3010 4x4		617cc	2001	2008			
	KAF620 Mule 3010 Trans 4x4		617cc	2005	2008			
	KAF620 Mule 3020		617cc	2001	2003			
	KAF620 Mule 4000		617cc	2009	2010			
	KAF620 Mule 4000		617cc	2011	2011			
	KAF620 Mule 4010 4x4		617cc	2009	2011			
	KAF620 Mule 4010 4x4		617cc	2012	2012			
	KAF620 Mule 4010 Trans 4x4		617cc	2009	2011			
	KAF620 Mule 4010 Trans 4x4		617cc	2012	2012			
	KAF950 Mule 2510 Diesel			2003	2007			
	KAF950 Mule 3010 Diesel 4x4		953cc	2003	2007			
KAF950 Mule 3010 Diesel 4x4		953cc	2005	2008				
KAF950 Mule 3010 Trans 4x4 Diesel		953cc	2007	2007				
KDX200			1995	2006				

BOBINE ACCENSIONE IGNITION COILS	REGOLATORI & RADDRIZ- ZATORI REGULATORS & RECTIFIERS	KIT RIPARAZIONE REPAIR KIT	INTERRUTTORI SOLENOIDI SOLENOID SWITCH	MOTORINI AVVIAMENTO STARTER	INGRANAGGI AVVIAMENTO STARTER DRIVES	KIT RIPARAZIONE MOTO- RINI AVVIAMENTO STARTER REPAIR KIT	STATORI STATORS
				19575N			
				19575N			
				19576N			
				19575N			
				19575N			
				19575N			
	KW1008N			19599N			
	KW1008N						
				19599N			
				18809N			
				18809N			
	KW1008N						
				19599N			
	KW1008N						
				19599N			
				19597N			
				19597N			
				19583N			
	KW1008N						
				19583N			
	KW1008N			19599N			
				19599N			
	KW1008N						
				18809N			
				18809N			
				18809N			
				19228N			
				19228N			
				19228N			
				19228N			
				19228N			
				19228N			
				19228N			
				19228N			
				19228N			
				19228N			
				19228N			
				19228N			
				19228N			
				19228N			
				18880N			
				18880N			
				18880N			
				18880N			
				19574N			
				19574N			
				19576N			
				19576N			
				19589N			
			66-8210	33285N			
				18331N			

ELECTRIC PARTS
ATV - UTV

ELECTRIC PARTS ATV - UTV

MARCA MAKE	MODELLO MODEL	CC CC	DA FROM	A TO	ALTERNATORE ALTERNATORE	CENTRALINA CDI	GENERATORE GENERATOR	
KAWASAKI	KDX200R		1997	2001				
	KDX220R		2002	2005				
	KDX250		1991	1995				
	KEF300 Lakota Sport	290cc	2001	2003				
	KEF300 Lakota Utility	290cc	1995	2000				
	KFX400	398cc	2003	2006				
	KFX450R	449cc	2008	2014				
	KFX700	697cc	2004	2005				
	KFX700	697cc	2004	2009				
	KFX80	79cc	2003	2006				
	KFX90	89cc	2007	2015				
	KL250 Super Sherpa			2000	2010			
	KLE650 Versys	649cc	2011	2014				
	KLE650 Versys	652cc	2008	2010				
	KLE650 Versys ABS	649cc	2014	2015				
	KLF110 Mojave	110cc	1987	1988				
	KLF110 Mojave 110E			1987	1988			
	KLF185 Bayou	185cc	1985	1988				
	KLF220 Bayou	215cc	1988	2002				
	KLF250 Bayou	228cc	2011	2011				
	KLF250 Bayou	249cc	2003	2010				
	KLF250 Bayou	249cc	2003	2011				
	KLF300 Bayou 2x4	290cc	1986	1991				
	KLF300 Bayou 2x4	290cc	1986	2004				
	KLF300 Bayou 4x4	290cc	1989	2004				
	KLF300 Bayou 4x4	290cc	1989	2005				
	KLF400 Bayou 4x4	398cc	1993	1999				
	KLR650	651cc	2011	2015				
	KLR650	652cc	1987	2010				
	KLT200	198cc	1981	1984				
	KLT250	248cc	1982	1984				
	KLT250	248cc	1983	1984				
	KLT250			1985	1985			
	KLX250			2006	2007			
	KLX400R	398cc	2003	2003				
	KLX400SR	398cc	2003	2003				
	KRF750 Teryx	749cc	2010	2010				
	KRF750 Teryx 4x4	749cc	2008	2009				
	KRF750 Teryx FI 4x4	--L 749cc -cid	2010	2013				
	KRF750 Teryx FI 4x4	749cc	2009	2013				
	KRF750 Teryx FI 4x4			2005	2005			
	KRF750 Teryx FI 4x4 LE	749cc	2008	2013				
	KRF750 Teryx FI 4x4 LE Camo	749cc	2013	2013				
	KRF750 Teryx FI 4x4 LE SGE	749cc	2011	2012				
	KRF750 Teryx FI 4x4 LE Sport	749cc	2009	2009				
	KRF750 Teryx FI 4x4 Sport	--L 749cc -cid	2012	2013				
	KRF750 Teryx FI 4x4 Sport	749cc	2009	2013				
KRF750 Teryx FI 4x4 Sport	749cc	2010	2013					
KRF750 Teryx LE	749cc	2008	2010					
KRF750 Teryx NRA Outdoors	749cc	2008	2009					

BOBINE ACCENSIONE	REGOLATORI & RADDRIZZATORI	KIT RIPARAZIONE	INTERRUTTORI SOLENOIDI	MOTORINI AVVIAMENTO	INGRANAGGI AVVIAMENTO	KIT RIPARAZIONE MOTORINI AVVIAMENTO	STATORI
IGNITION COILS	REGULATORS & RECTIFIERS	REPAIR KIT	SOLENOID SWITCH	STARTER	STARTER DRIVES	STARTER REPAIR KIT	STATORS
CPS30							
	PL1009N			18331N			
CPS30							
	PL1009N						
CPS30							27-7068
				19622N			
				19622N			
				18645N		79-85118	
	PL1012N						
				18645N		79-85118	
				18645N		79-85118	
CPS30	PL1010N			18331N			
	PL1010N			18331N			
CPS30							
CPS30	PL1010N						
CPS30	PL1010N						
				18331N			
				18331N			
	PL1010N						
CPS30				18331N			
	PL1009N						
	PL1008N					79-85118	27-7010
				18645N			
							27-7010
						79-85118	
	PL1008N			18645N		79-85118	27-7010
	PL1008N			18645N		79-85118	
				19622N			
	PL1022N						
				18912N			
				18645N			
				34022N			
			67-777				27-7068
				34050N			
	OL1023N		67-777				
				18912N			
	PL1022N						27-7068
	PL1004N			18645N		79-85118	
	PL1004N			18645N		79-85118	
				18645N		79-85118	
				18645N		79-85118	
	PL1009N						
				18645N		79-85118	27-7013
	PL1004N						
	PL1009N						
				18645N		79-85118	27-7013
	PL1004N						
	PL1009N						

ELECTRIC PARTS ATV - UTV

MARCA MAKE	MODELLO MODEL	CC CC	DA FROM	A TO	ALTERNATORE ALTERNATORE	CENTRALINA CDI	GENERATORE GENERATOR
KAWASAKI	KRF750 Teryx NRA Outdoors		2008	2008			
	KRF750 Teryx Sport	749cc	2009	2010			
	KRF800 Teryx Camo	-- 783cc	2015	2015			
	KRF800 Teryx LE	-- 783cc	2015	2015			
	KRT750 Teryx4 4x4	749cc	2012	2012			
	KRT750 Teryx4 4x4 EPS	749cc	2012	2013			
	KRT750 Teryx4 4x4 EPS Camo	749cc	2013	2013			
	KRT750 Teryx4 4x4 EPS LE	749cc	2012	2013			
	KRT750 Teryx4 4x4 EPS LE Camo	749cc	2012	2012			
	KRT800 Teryx4	-- 783cc	2014	2015			
	KRT800 Teryx4 Camo	-- 783cc	2014	2015			
	KRT800 Teryx4 LE	-- 783cc	2014	2015			
	KVF300 Prairie 2x4	290cc	1999	2002			
	KVF300 Prairie 4x4	290cc	1999	2002			
	KVF360 Prairie 2x4	362cc	2003	2008			
	KVF360 Prairie 2x4	362cc	2003	2009			
	KVF360 Prairie 2x4	362cc	2009	2009			
	KVF360 Prairie 4x4	362cc	2003	2008			
	KVF360 Prairie 4x4	362cc	2003	2012			
	KVF360 Prairie 4x4	362cc	2009	2013			
	KVF400 Prairie 2x4	398cc	1998	2002			
	KVF400 Prairie 4x4	398cc	1997	2002			
	KVF650 Brute Force 4x4	633cc	2005	2013			
	KVF650 Brute Force 4x4i	633cc	2006	2013			
	KVF650 Prairie 4x4	633cc	2002	2003			
	KVF700 Prairie 4x4	697cc	2004	2006			
	KVF750 Brute Force 4x4i	-- L 749cc -cid	2008	2011			
	KVF750 Brute Force 4x4i	749cc	2005	2014			
	KVF750 Brute Force 4x4i	749cc	2005	2015			
	KVF750 Brute Force 4x4i EPS	749cc	2012	2015			
	KVF750 Brute Force 4x4i EPS	749cc	2012	2016			
	KZ1000A/J	1015cc	1981	1983			
	KZ1000B/K LTD	1015cc	1981	1981			
	KZ1000C/P Police	1015cc	1982	2005			
	KZ1000C/P Police	1015cc	1986	1989			
	KZ1000M CSR	1015cc	1981	1982			
	KZ1000R Lawson Replica	1015cc	1982	1983			
	KZ1100A	1089cc	1981	1983			
	KZ1100D Spectre	1089cc	1982	1983			
	KZ1100L LTD Shaft	1089cc	1983	1983			
	KZ250 CSR		1980	1981			
	KZ250 CSR Belt		1982	1982			
	KZ440 Sports Belt		1982	1982			
	KZ440A LTD	444cc	1980	1983			
KZ440B/G	444cc	1980	1981				
KZ440D LTD Belt	444cc	1980	1983				
KZ550A	550cc	1980	1983				
KZ550C LTD	550cc	1980	1983				
KZ550D/H GPZ	550cc	1981	1983				
KZ550F LTD Shaft	550cc	1984	1984				

BOBINE ACCENSIONE	REGOLATORI & RADDRIZZATORI	KIT RIPARAZIONE	INTERRUTTORI SOLENOIDI	MOTORINI AVVIAMENTO	INGRANAGGI AVVIAMENTO	KIT RIPARAZIONE MOTORINI AVVIAMENTO	STATORI
IGNITION COILS	REGULATORS & RECTIFIERS	REPAIR KIT	SOLENOID SWITCH	STARTER	STARTER DRIVES	STARTER REPAIR KIT	STATORS
						79-85118	27-7013
	PL1009N					79-85118	27-7013
	PL1009N			18645N		79-85118	27-7013
	PL1008N			18645N		79-85118	
	PL1012N					79-85118	
							27-7010
	PL1008N			18645N			
							27-7010
	PL1012N						27-7013
				18644N			
				18647N		79-85118	
				19621N			
				18563N			
				18647N		79-85118	
				18644N			27-7019
	PL1004N			18645N		79-85118	
	PL1012N			18645N		79-85118	
				18645N		79-85118	
			67-777				
				18645N			
			67-777	18645N		79-85118	
	OL1023N						
			67-777	18645N		79-85118	
	PL1004N						
				18645N		79-85118	
			67-777				
				18645N			
			67-777	18645N		79-85118	
						79-85118	
			67-777				
			67-777				
			67-777				
			67-777				
				18645N			
			67-777				
			67-777				
			67-777				
	PL1008N						
				18645N		79-85118	
							27-7010
			67-777				
			67-777				
			67-777				
			67-777				
							27-7068
			67-777	34050N			27-7069

ELECTRIC PARTS
ATV - UTV

ELECTRIC PARTS ATV - UTV

MARCA MAKE	MODELLO MODEL	CC CC	DA FROM	A TO	ALTERNATORE ALTERNATORE	CENTRALINA CDI	GENERATORE GENERATOR
KAWASAKI	KZ550F Spectre	550cc	1983	1983			
	KZ550M LTD Shaft	550cc	1983	1983			
	KZ650B/F	650cc	1980	1980			
	KZ650E LTD	650cc	1980	1980			
	KZ750G LTD II	750cc	1980	1980			
	KZ750M CSR	750cc	1982	1982			
	VN1500A Vulcan 1500	1471cc	1996	1999			
	VN1500A Vulcan 88	1471cc	1987	1991			
	VN1500B Vulcan 88 SE	1471cc	1987	1990			
	VN700 LTD			1985	1985		
	VN700A Vulcan	699cc	1985	1985			
	VN750A Vulcan 750	749cc	1986	1993			
	VN750A Vulcan 750	749cc	1986	1998			
	ZG1000 Concours	997cc	1986	1989			
	ZL1000 Eliminator	997cc	1987	1987			
	ZL600 Eliminator	592cc	1986	1987			
	ZN1100 LTD Shaft			1984	1985		
	ZN1100B LTD	1089cc	1984	1985			
	ZN700 LTD Shaft			1984	1985		
	ZN700A LTD	694cc	1984	1985			
	ZR-7	738cc	2000	2000			
	ZR-7S	738cc	2001	2005			
	ZR750C Zephyr	738cc	1991	1993			
	ZR750C Zephyr	738cc	1992	1993			
	ZX1000 Ninja 1000R	998cc	1986	1987			
	ZX1100 GPZ	1089cc	1983	1984			
	ZX1100 GPZ			1985	1985		
	ZX550 GPZ	553cc	1984	1985			
	ZX600 Ninja 600			1985	1989		
	ZX600 Ninja 600R	599cc	1988	1993			
	ZX600 Ninja 600R	599cc	1990	1997			
	ZX600 Ninja 600RX			1987	1987		
	ZX600 Ninja ZX-6	599cc	1990	1990			
	ZX600 Ninja ZX-6	599cc	1990	2001			
	ZX600 Ninja ZX-6R	599cc	1995	1997			
	ZX750 GPZ	739cc	1983	1985			
	ZX750 Ninja ZX-7	748cc	1989	1995			
	ZX750 Ninja ZX-7R	748cc	1991	2003			
	ZX750 Ninja ZX-7RR	748cc	1996	1997			
	ZX750F Ninja 750R	748cc	1987	1990			
KAZUMA	Baby Falcon 110						
	Cougar 250						
	Dingo 150						
	Dingo 250						
	Falcon 110						
	Falcon 150						
	Falcon 250						
	Kat 150						
	Lacoste 110						
	Lacoste 150						

BOBINE ACCENSIONE	REGOLATORI & RADDRIZZATORI	KIT RIPARAZIONE	INTERRUTTORI SOLENOIDI	MOTORINI AVVIAMENTO	INGRANAGGI AVVIAMENTO	KIT RIPARAZIONE MOTORINI AVVIAMENTO	STATORI
IGNITION COILS	REGULATORS & RECTIFIERS	REPAIR KIT	SOLENOID SWITCH	STARTER	STARTER DRIVES	STARTER REPAIR KIT	STATORS
			67-777			79-85118	27-7068
				18648N			
			67-777	18648N			
			67-777				27-7068
	PL1015N		67-777				
			67-777				
			67-777				
			67-777	18648N			
			67-777	18648N			
							27-7068
	PL1015N		67-777				
			67-777				
			67-777	18648N			
			67-777	18648N			
			67-777				
			67-777				
				18563N			
				19622N			27-7068
				19622N			
				19622N			
				18331N			
			67-748				
CPS30	PL1010N						
				18331N			
	PL1021N						
	PL1010N						
CPS30				18331N			
	PL1021N						
						79-85118	27-7010
	PL1008N			18645N		79-85118	
			67-777			79-85118	
							27-7010
	PL1008N						
				18645N		79-85118	
	PL1012N						
			67-777				
	OL1023N						
			67-777	18645N		79-85118	
				19622N			
				19622N			
				19622N			
				18644N			
							27-7019
	PL1010N						
				18331N			
	PL1021N						
				19494N			
				19622N			

ELECTRIC PARTS
ATV - UTV

ELECTRIC PARTS ATV - UTV

MARCA MAKE	MODELLO MODEL	CC CC	DA FROM	A TO	ALTERNATORE ALTERNATORE	CENTRALINA CDI	GENERATORE GENERATOR
KAZUMA	MeerKat 50						
	Mini Falcon 90						
	Panda 110						
	Viper 110 Dirt Bike						
KUBOTA	RTV1100		2007	2007	11634N		
	RTV400Ci	-- 404cc	2012	2013			
	RTV500 4x4	454cc	2008	2015	22581N		
KYMCO	RTV900	898cc	2004	2011	12534N		
	Maxxer 250	--L 249cc -cid	2008	2008			
	Maxxer 300	270cc	2006	2010			
	Maxxer 300	270cc	2008	2008			
	Maxxer 375 4x4	367cc	2012	2012			
	Maxxer 375 4x4 IRS	366cc	2010	2011			
	Mongoose 250	--L 249cc -cid	2004	2009			
	Mongoose 250	250cc	2004	2008			
	Mongoose 300	270cc	2006	2010			
	Mongoose 300	270cc	2006	2014			
	Mongoose 50	49cc	2004	2009			
	Mongoose 70	69cc	2007	2010			
	Mxer 150	149cc	2002	2004			
	MXU150	149cc	2005	2010			
	MXU150	149cc	2005	2014			
	MXU250	--L 249cc -cid	2004	2009			
	MXU300	270cc	2005	2014			
	MXU300	270cc	2006	2010			
	MXU375 4x4 IRS	366cc	2012	2013			
	MXU375 IRS	366cc	2010	2011			
	MXU375 IRS LE	366cc	2011	2011			
	MXU500	499cc	2006	2009			
	MXU500 4x4 IRS	499cc	2012	2014			
	MXU500 IRS	499cc	2010	2011			
	MXU500i 4x4 IRS	499cc	2012	2014			
	MXU500i 4x4 IRS LE	499cc	2012	2014			
	UXV 500 4X4 SE	498cc	2011	2011			
	UXV 500i 4X4	499cc	2012	2014			
UXV 500i HE	499cc	2014	2014				
UXV 500i LE	499cc	2012	2014				
UXV 500i SE	498cc	2012	2012				
UXV 500i SE	499cc	2013	2013				
UXV 500i SP	499cc	2013	2014				
UXV 500i TURF	499cc	2014	2014				
LYNX	Adventure V-800		2007	2008			
	Ranger V-800		2008	2008			
	Xtrim SC 800		2008	2008			
MASSEY FERGUSON	YETI V-800 Pro		2006	2008			
	MF-1547		2005	2015	12650N		
MAXAM	MX150 LE		2004	2008			
	MX150 Sport		2004	2008			
	MX50		2004	2008			
	MX50 Mini		2004	2008			

BOBINE ACCENSIONE	REGOLATORI & RADDRIZZATORI	KIT RIPARAZIONE	INTERRUTTORI SOLENOIDI	MOTORINI AVVIAMENTO	INGRANAGGI AVVIAMENTO	KIT RIPARAZIONE MOTORINI AVVIAMENTO	STATORI
IGNITION COILS	REGULATORS & RECTIFIERS	REPAIR KIT	SOLENOID SWITCH	STARTER	STARTER DRIVES	STARTER REPAIR KIT	STATORS
				19622N			
	PL1022N			18912N			
			67-777				
				18645N			
	PL1004N					79-85118	27-7013
	PL1010N						
CPS30							
	PL1004N						27-7013
				18331N		79-85118	
	PL1012N						
				18331N			
	PL1009N						
				19619N			
	PL1022N			19619N			
						79-85118	
				18645N			
	OL1023N		67-777				
				34022N			
				34022N			
CPS30							
				18331N			
				18645N		79-85118	
			67-777				
	PL1009N						27-7013
							27-7013
	PL1009N						
				18645N		79-85118	
	PL1008N						27-7010
							27-7010
	PL1008N						
				18645N		79-85118	
	PL1012N						
			67-777				
							27-7010
			67-777	18645N		79-85118	
				18645N			
			67-777				
				18645N		79-85118	
				18645N			
				18645N			
			67-777				
			67-777	18645N			
			67-777				
				18645N		79-85118	
			67-777				
	PL1008N						
				18645N			
						79-85118	
	PL1012N						
			67-777				

ELECTRIC PARTS ATV - UTV

MARCA MAKE	MODELLO MODEL	CC CC	DA FROM	A TO	ALTERNATORE ALTERNATORE	CENTRALINA CDI	GENERATORE GENERATOR
MILLER ELECTRIC	Bobcat 225						
	Bobcat 250						
MOUNTAINEER	All		2005	2008			
	Porter		1998	1998			
PIAGGIO	300 2x4	294cc	1994	1995			
	400L 2x4	400cc	1994	1995			
POLARIS	400L 2x4	400cc	1995	1995			
	400L 2x4		1994	1994			
	400L 4x4	400cc	1994	1994			
	400L 4x4	400cc	1994	1995			
	570 Forest Tractor		2015	2015			
	850 Forest		2015	2015			
	850 Scrambler HO EPS		2013	2014			
	ATP 330	329cc	2004	2005			
	ATP 500	499cc	2004	2004			
	ATP 500	499cc	2004	2005			
	ATV Pro 500 4x4 PPS		2002	2002			
	Big Boss 250 4x6	249cc	1989	1992			
	Big Boss 250 6x6	249cc	1991	1993			
	Big Boss 250 6x6	249cc	1991	1994			
	Big Boss 300 2x4		1994	1995			
	Big Boss 300 4x4		1994	1995			
	Big Boss 300 6x6	298cc	1994	1994			
	Big Boss 350L 6x6	350cc	1993	1993			
	Big Boss 400L 6x6	400cc	1994	1997			
	Big Boss 400L 6x6	400cc	1995	1997			
	Big Boss 400L 6x6		1994	1994			
	Big Boss 500 6x6	500cc	1998	1999			
	Big Boss 500 6x6	500cc	1998	2002			
	Big Boss 500 6X6 INT'L	499cc	1998	2001			
	Big Boss 500 6X6 INT'L		1999	2002			
	Big Boss 500 6X6 Norweigen		1998	1998			
	Big Boss 500 6X6 Swedish		1998	1998			
	Brutus	904cc	2013	2014			
	Forest 1000		2015	2015			
	Hawkeye 2x4	299cc	2006	2011			
	Hawkeye 2x4	300cc	2006	2010			
	Hawkeye 2x4	300cc	2015	2015			
	Hawkeye 2x4	455cc	2013	2013			
	Hawkeye 2x4		2011	2012			
	Hawkeye 325		2015	2015			
	Hawkeye 400 HO		2011	2014			
	Hawkeye 4x4	300cc	2006	2007			
	Hawkeye 4x4	300cc	2006	2008			
	M1400	325cc	2015	2015			
	Magnum 325 2x4	325cc	2000	2002			
	Magnum 325 4x4	325cc	2000	2002			
	Magnum 330 2x4	329cc	2003	2005			
	Magnum 330 4x4	329cc	2003	2006			
	Magnum 425 2x4	425cc	1995	1997			

BOBINE ACCENSIONE IGNITION COILS	REGOLATORI & RADDRIZ- ZATORI REGULATORS & RECTIFIERS	KIT RIPARAZIONE REPAIR KIT	INTERRUTTORI SOLENOIDI SOLENOID SWITCH	MOTORINI AVVIAMENTO STARTER	INGRANAGGI AVVIAMENTO STARTER DRIVES	KIT RIPARAZIONE MOTO- RINI AVVIAMENTO STARTER REPAIR KIT	STATORI STATORS
	OL1023N			18645N			
	OL1023N		67-777	34022N		79-85118	
			67-777	34022N			
	PL1008N			18645N		79-85118	
	OL1023N		67-777	18645N			
				34022N			
	PL1008N			18645N			27-7010
							27-7013
				18645N			27-7010
			67-777				
			67-777				
			67-777				
			67-777				
	PL1008N			18645N		79-85118	
			67-777				
				19089N			
				19089N			
			67-777				
				19089N			
				19089N			
				19089N			
			67-777	19089N			
				19089N			
				19089N			
				19089N			
				19089N			
				19089N			
			67-777				
				19089N			
				19089N			
			67-777				27-7068
			67-777				27-7068
			67-777				
			67-777				27-7068
			67-777				
							27-7068
			67-777				
	PL1012N			18648N			
				18648N			
				18648N			

ELECTRIC PARTS
ATV - UTV

ELECTRIC PARTS ATV - UTV

MARCA MAKE	MODELLO MODEL	CC CC	DA FROM	A TO	ALTERNATORE ALTERNATORE	CENTRALINA CDI	GENERATORE GENERATOR
POLARIS	Magnum 425 2x4	425cc	1995	1998			
	Magnum 425 2x4	425cc	1998	1998			
	Magnum 425 4x4	425cc	1995	1997			
	Magnum 425 4x4	425cc	1995	1998			
	Magnum 425 4x4	425cc	1998	1998			
	Magnum 425 4X4 Norweigen	425cc	1995	1998			
	Magnum 425 4X4 Norweigen		1995	1997			
	Magnum 425 4X4 Swedish	425cc	1995	1998			
	Magnum 425 4X4 Swedish		1995	1997			
	Magnum 425 6x6	425cc	1996	1997			
	Magnum 500 2x4	499cc	2002	2002			
	Magnum 500 2x4		2003	2003			
	Magnum 500 4x4	499cc	1999	2000			
	Magnum 500 4x4	499cc	1999	2002			
	Magnum 500 4x4	499cc	1999	2003			
	Magnum 500 HDS	499cc	2000	2000			
	Magnum 500 HDS		2003	2003			
	Magnum 6X6 Swedish	425cc	1996	1997			
	Outlaw 50	49cc	2008	2009			
	Outlaw 500	499cc	2006	2007			
	Outlaw 90	89cc	2007	2014			
	Phoenix 200	196cc	2005	2014			
	Predator 500	499cc	2003	2007			
	Predator 90	89cc	2003	2006			
	Ranger 2x4 425	425cc	2001	2002			
	Ranger 2x4 425	425cc	2001	2004			
	Ranger 2x4 425	425cc	2002	2003			
	Ranger 2x4 425	425cc	2004	2004			
	Ranger 2x4 500	499cc	2005	2009			
	Ranger 2x4 500	499cc	2007	2009			
	Ranger 2x4 500		2004	2004			
	Ranger 400 Midsize			2013	2013		
	Ranger 4x4 400	455cc	2010	2014			
	Ranger 4x4 400	455cc	2012	2014			
	Ranger 4x4 400	499cc	2010	2011			
	Ranger 4x4 500	499cc	2001	2002			
	Ranger 4x4 500	499cc	2001	2007			
	Ranger 4x4 500	499cc	2007	2007			
	Ranger 4x4 500		2012	2012			
	Ranger 4x4 500 EFI	499cc	2006	2011			
	Ranger 4x4 500 EFI		2012	2013			
	Ranger 4x4 500 EFI		2012	2014			
	Ranger 4x4 700		2005	2009			
	Ranger 4x4 700 EFI	683cc	2007	2007			
	Ranger 4x4 700 EFI		2008	2009			
	Ranger 4x4 900 Dsl.		2011	2014			
	Ranger 500 Crew	498cc	2011	2013			
	Ranger 500 Midsize		2013	2013			
	Ranger 570 Crew	567cc	2015	2015			
	Ranger 570 EFI	567cc	2014	2014			

BOBINE ACCENSIONE	REGOLATORI & RADDRIZZATORI	KIT RIPARAZIONE	INTERRUTTORI SOLENOIDI	MOTORINI AVVIAMENTO	INGRANAGGI AVVIAMENTO	KIT RIPARAZIONE MOTORINI AVVIAMENTO	STATORI
IGNITION COILS	REGULATORS & RECTIFIERS	REPAIR KIT	SOLENOID SWITCH	STARTER	STARTER DRIVES	STARTER REPAIR KIT	STATORS
	PL1012N						
				18648N			
	PL1019N						
			67-777				
			67-777	18648N			
				18648N			
				18648N			
			67-777	18648N			
	PL1019N						
				18648N			
			67-777				
			67-777	18648N			
			67-777				
				18648N			
			67-777				
				18648N			
			67-777	18648N			
			67-777	18648N			
				18648N			
				18648N			
				18648N			
				18648N			
				18648N			
				19622N			
				19622N			
				19622N			
				19622N			
				19622N			
				19622N			
				19622N			
				19622N			
				19622N			
				19622N			
				19622N			
				19622N			
				19622N			
				19622N			
				19622N			
				19622N			
				19622N			
				19622N			
				18644N			27-7019
				19621N			
							27-7069
				34050N			
				18645N			
				34022N			
				19089N			
				18648N			
				18648N			
				19622N			
				19622N			
				34022N			
				19089N			

ELECTRIC PARTS
ATV - UTV

ELECTRIC PARTS ATV - UTV

MARCA MAKE	MODELLO MODEL	CC CC	DA FROM	A TO	ALTERNATORE ALTERNATORE	CENTRALINA CDI	GENERATORE GENERATOR
POLARIS	Ranger 570 EFI		2015	2015			
	Ranger 570 EPS Full-Size	--L 567cc -cid	2016	2016			
	Ranger 6x6 500	499cc	1998	2002			
	Ranger 6x6 500	499cc	1998	2005			
	Ranger 6x6 500	499cc	1999	1999			
	Ranger 6x6 500	499cc	2004	2004			
	Ranger 6x6 700 EFI	683cc	2006	2009			
	Ranger 6x6 800	760cc	2010	2014			
	Ranger 6x6 800	760cc	2013	2015			
	Ranger 6X6 EFI		2006	2009			
	Ranger 800 Crew	760cc	2011	2014			
	Ranger 800 EFI	760cc	2011	2014			
	Ranger 800 EFI		2010	2010			
	Ranger 800 EFI Mid-Size	760cc	2013	2014			
	Ranger 800 XP	760cc	2010	2012			
	Ranger 800 XP	760cc	2012	2012			
	Ranger 900 Crew	--L 875cc -cid	2013	2015			
	Ranger 900 Crew EPS	--L 875cc -cid	2014	2014			
	Ranger 900 Crew EPS LE	--L 875cc -cid	2014	2014			
	Ranger 900 XP	--L 875cc -cid	2013	2013			
	Ranger 900 XP	--L 875cc -cid	2013	2015			
	Ranger 900 XP	--L 875cc -cid	2014	2014			
	Ranger 900 XP	875cc	2013	2014			
	Ranger 900 XP Bronze Mist LE	--L 875cc -cid	2013	2013			
	Ranger 900 XP EPS	--L 875cc -cid	2013	2014			
	Ranger 900 XP EPS Browning LE	--L 875cc -cid	2013	2014			
	Ranger 900 XP EPS LE	--L 875cc -cid	2013	2014			
	Ranger 900 XP LE	--L 875cc -cid	2013	2013			
	Ranger ETX	325cc	2015	2015			
	Ranger ETX	325cc	2016	2016			
	Ranger RZR 4 800	760cc	2012	2013			
	Ranger RZR 4 800 EPS LE	760cc	2013	2013			
	Ranger RZR 4 800 EPS Robby Gordon	760cc	2011	2011			
	Ranger RZR 4 800 EPS Robby Gordon LE	760cc	2012	2012			
	Ranger RZR 4 800 Gordon Edition	760cc	2011	2012			
	Ranger RZR 4 EPS Robby Gordon	760cc	2011	2011			
	Ranger RZR 4 Robby Gordon Edition	760cc	2011	2011			
	Ranger RZR 570	567cc	2012	2013			
	Ranger RZR 570 EPS Trail LE	567cc	2013	2013			
	Ranger RZR 800	760cc	2011	2013			
	Ranger RZR 800 EFI		2008	2009			
	Ranger RZR 800 EPS	760cc	2011	2011			
	Ranger RZR 800 EPS LE	760cc	2012	2013			
	Ranger RZR 800 LE	760cc	2012	2013			
	Ranger RZR 800 S	760cc	2011	2013			
	Ranger RZR 800 S LE	760cc	2012	2013			
Ranger RZR 800 SW Military	760cc	2011	2011				
Ranger RZR S 800 EPS LE	760cc	2013	2013				
Ranger RZR XP 4 900	--L 875cc -cid	2012	2012				
Ranger RZR XP 4 900	--L 875cc -cid	2013	2013				

BOBINE ACCENSIONE	REGOLATORI & RADDRIZZATORI	KIT RIPARAZIONE	INTERRUTTORI SOLENOIDI	MOTORINI AVVIAMENTO	INGRANAGGI AVVIAMENTO	KIT RIPARAZIONE MOTORINI AVVIAMENTO	STATORI
IGNITION COILS	REGULATORS & RECTIFIERS	REPAIR KIT	SOLENOID SWITCH	STARTER	STARTER DRIVES	STARTER REPAIR KIT	STATORS
				18648N			
				18648N			
				18648N			
				19089N			
				19089N			
				19089N			
				19486N			
CPS30				18331N			
	PL1010N						
	PL1021N						
						79-85118	
			67-777	18645N			
	OL1023N						
CPS30	PL1021N			18331N			
CPS30							
	PL1010N						
				18331N			
				18331N			
				18331N			
				18331N			
				18331N			
				18331N			
				18331N			
	PL1004N			18645N		79-85118	
						79-85118	
				18645N			
			67-777				
	OL1023N						
CPS30	PL1010N			18331N			
CPS30	PL1010N			18331N			
	PL1004N			18645N		79-85118	27-7013
	PL1008N			18645N		79-85118	27-7010
				18645N			
	PL1004N			18641N			
	PL1004N			18641N			
CPS30	PL1021N			18331N			
	PL1010N						
CPS30							
				18331N			
	PL1009N						
CPS30				18331N			
	PL1004N						
				18331N			
	PL1009N			18645N		79-85118	27-7013
	PL1010N						
CPS30				18331N			
	PL1009N						
CPS30	PL1009N			18331N			
				19577N			

ELECTRIC PARTS
ATV - UTV

ELECTRIC PARTS ATV - UTV

MARCA	MODELLO	CC	DA	A	ALTERNATORE	CENTRALINA	GENERATORE
MAKE	MODEL	CC	FROM	TO	ALTERNATORE	CDI	GENERATOR
POLARIS	Ranger RZR XP 4 900 EPS LE	--L 875cc -cid	2013	2013			
	Ranger RZR XP 900	--L 875cc -cid	2011	2012			
	Ranger RZR XP 900	--L 875cc -cid	2013	2013			
	Ranger RZR XP 900 HO Jagged X Edition	--L 875cc -cid	2013	2013			
	Ranger TM		2004	2006			
	Ranger XP 700	683cc	2006	2006			
	RZR 1000 XP		2014	2015			
	RZR 1000 XP Int'l		2014	2015			
	RZR 4		2011	2011			
	RZR 4 1000 XP		2014	2015			
	RZR 4 800 EFI		2010	2014			
	RZR 4 800 EPS LE	875cc	2014	2014			
	RZR 4 900 EPS	--L 875cc -cid	2015	2016			
	RZR 4 900 EPS LE	--L 875cc -cid	2014	2015			
	RZR 4 900 XP		2012	2015			
	RZR 4 900 XP		2013	2014			
	RZR 4 900 XP EFI		2013	2013			
	RZR 570	567cc	2014	2014			
	RZR 570	567cc	2014	2015			
	RZR 570		2013	2013			
	RZR 570 EPS Trail LE	567cc	2014	2014			
	RZR 800	760cc	2013	2014			
	RZR 800	760cc	2014	2014			
	RZR 800		2008	2012			
	RZR 800 EPS LE	760cc	2014	2014			
	RZR 900	--L 875cc -cid	2014	2014			
	RZR 900	--L 875cc -cid	2015	2015			
	RZR 900 EPS		2014	2014			
	RZR 900 EPS Int'l		2014	2014			
	RZR 900 EPS LE	--L 875cc -cid	2014	2015			
	RZR 900 XP EFI		2012	2013			
	RZR 900 XP EFI		2013	2013			
	RZR 900 XP EPS		2013	2013			
	RZR S 800	760cc	2013	2014			
	RZR S 800	760cc	2014	2014			
	RZR S 800		2009	2012			
	RZR S 800 EPS LE	760cc	2014	2014			
	RZR S 900 EPS	875cc	2015	2015			
	RZR XP 1000 EPS	--L 999cc -cid	2014	2015			
	RZR XP 1000 EPS	--L 999cc -cid	2015	2016			
	RZR XP 4 1000 EPS	999cc	2014	2016			
	RZR XP 4 1000/PS		2014	2015			
	RZR XP 4 900 EFI		2013	2013			
	RZR XP 4 Turbo EPS	--L 925cc -cid	2016	2016			
	RZR XP 900		2013	2013			
Sawtooth	196cc	2006	2007				
Scrambler 1000 XP	--952cc	2016	2016				
Scrambler 1000 XP EPS	--952cc	2014	2015				
Scrambler 1000 XP HO EPS		2014	2014				
Scrambler 250	244cc	1985	1986				

BOBINE ACCENSIONE	REGOLATORI & RADDRIZZATORI	KIT RIPARAZIONE	INTERRUTTORI SOLENOIDI	MOTORINI AVVIAMENTO	INGRANAGGI AVVIAMENTO	KIT RIPARAZIONE MOTORINI AVVIAMENTO	STATORI
IGNITION COILS	REGULATORS & RECTIFIERS	REPAIR KIT	SOLENOID SWITCH	STARTER	STARTER DRIVES	STARTER REPAIR KIT	STATORS
				19577N			
				19572N			
				19575N			
				19575N			
				19575N			
				19575N			
				19572N			
	S1008N						
	S1008N						
				18880N			
				18880N			
				18880N			
				18880N			
				18880N			
				18880N			
				19586N			
				19631N			
	S1034N						
				18790N			
				18790N			
				18796N			
				18790N			
				18718N			
				18718N			
				18718N			
				18718N			
CPS27							
						79-85112	
						79-85112	
						79-85112	
CPS27							
CPS27							
CPS27							
CPS27							
						79-85112	
CPS27							
						79-85112	
						79-85112	
						79-85112	
						79-85112	
CPS27							
CPS27							
		79-85107					
						79-85112	
	S1032						
						79-85112	
	S1032						
						79-85101	
						79-85101	

ELECTRIC PARTS
ATV - UTV

ELECTRIC PARTS ATV - UTV

MARCA MAKE	MODELLO MODEL	CC CC	DA FROM	A TO	ALTERNATORE ALTERNATORE	CENTRALINA CDI	GENERATORE GENERATOR	
POLARIS	Scrambler 250	244cc	1986	1986				
	Scrambler 400 2x4	400cc	1997	2002				
	Scrambler 400 2x4	400cc	2000	2002				
	Scrambler 400 2x4		1997	1997				
	Scrambler 400 4x4	400cc	1995	2002				
	Scrambler 400 4x4	400cc	1999	2002				
	Scrambler 400 4x4		1995	1997				
	Scrambler 500 2x4	499cc	1997	2000				
	Scrambler 500 2x4	499cc	2001	2002				
	Scrambler 500 2x4 Intl.			2007	2009			
	Scrambler 500 4x4	498cc	2011	2012				
	Scrambler 500 4x4	499cc	1997	2000				
	Scrambler 500 4x4	499cc	1997	2002				
	Scrambler 500 4x4	499cc	1997	2010				
	Scrambler 500 4x4	499cc	2003	2003				
	Scrambler 500 4x4	499cc	2007	2010				
	Scrambler 500 4x4	499cc	2010	2012				
	Scrambler 850	850cc	2015	2015				
	Scrambler 850 XP HO	850cc	2013	2014				
	Scrambler 850 XP HO EPS LE	850cc	2013	2014				
	Scrambler 90	89cc	2001	2002				
	Scrambler 90	89cc	2001	2003				
	Sport 400L	400cc	1994	1999				
	Sport 400L	400cc	1999	1999				
	Sport 400L			1994	1997			
	Sportsman & Ranger 570	570cc	2014	2015				
	Sportsman 1000 Touring XP	-- 952cc	2015	2015				
	Sportsman 1000 XP	-- 952cc	2015	2015				
	Sportsman 300	283cc	2008	2010				
	Sportsman 325 Ace EFI			2014	2014			
	Sportsman 335	335cc	1998	2000				
	Sportsman 335	335cc	1999	2000				
	Sportsman 350			1993	1993			
	Sportsman 400	400cc	1994	1997				
	Sportsman 400	400cc	2001	2002				
	Sportsman 400	400cc	2001	2005				
	Sportsman 400	400cc	2003	2004				
	Sportsman 400 4x4	400cc	1993	1996				
	Sportsman 400 4x4	400cc	1994	1996				
	Sportsman 400 HO	400cc	2007	2007				
	Sportsman 400 HO	455cc	2008	2010				
	Sportsman 400 HO	455cc	2011	2011				
	Sportsman 400 HO	455cc	2011	2012				
	Sportsman 400 HO	455cc	2011	2014				
	Sportsman 400 HO	455cc	2012	2012				
Sportsman 400 HO South Edition	455cc	2013	2014					
Sportsman 400L	400cc	1997	1997					
Sportsman 400L			1994	1999				
Sportsman 450	455cc	2006	2007					
Sportsman 450	455cc	2007	2007					

BOBINE ACCENSIONE IGNITION COILS	REGOLATORI & RADDRIZ- ZATORI REGULATORS & RECTIFIERS	KIT RIPARAZIONE REPAIR KIT	INTERRUTTORI SOLENOIDI SOLENOID SWITCH	MOTORINI AVVIAMENTO STARTER	INGRANAGGI AVVIAMENTO STARTER DRIVES	KIT RIPARAZIONE MOTO- RINI AVVIAMENTO STARTER REPAIR KIT	STATORI STATORS
CPS27						79-85101	
		79-85107		18808N			
		79-85107		18808N			
			67-748				
				18808N			
				18808N			
						79-85112	
		79-85107		18807N			
				18807N			
				18332N			
						79-85110	
			67-748	18809N			
			67-748	18809N			
							27-7070
	S1034N			19631N			
				19631N			
				19631N			
	S1019N			18796N			
			67-748	18796N			
				18810N			
				19488N			
				18810N			
				19488N			
		79-85107					
				18808N			
				18808N			
				18808N			
	S1016N	79-85107	67-748				
				18808N			
		79-85107					
				18807N			
				18807N			
		79-85107		18807N			
			67-748	18809N			
			67-748	18809N			
				18809N			
							27-7070
							27-7070
		79-85107		18807N			
	S1009N		67-748	18796N			
				18796N			
			67-748				
				19632N			
				18719N			
		79-85107	67-748	18808N			
	S1016N						
	S1016N						27-7045
	S1016N		67-748				27-7045
				18718N			
			67-748				
				19630N			

ELECTRIC PARTS ATV - UTV

MARCA MAKE	MODELLO MODEL	CC CC	DA FROM	A TO	ALTERNATORE ALTERNATORE	CENTRALINA CDI	GENERATORE GENERATOR
POLARIS	Sportsman 50	499cc	1997	1997			
	Sportsman 500	499cc	1996	1997			
	Sportsman 500 4x4	499cc	1996	1997			
	Sportsman 500 4x4	499cc	1996	2000			
	Sportsman 500 4x4	499cc	1998	2000			
	Sportsman 500 6x6	499cc	2000	2001			
	Sportsman 500 6x6	499cc	2000	2002			
	Sportsman 500 6x6	499cc	2000	2008			
	Sportsman 500 6x6	499cc	2003	2003			
	Sportsman 500 6x6	499cc	2007	2008			
	Sportsman 500 Duse	499cc	2001	2001			
	Sportsman 500 EFI	499cc	2006	2009			
	Sportsman 500 EFI Deluxe	499cc	2007	2007			
	Sportsman 500 EFI Touring	499cc	2008	2009			
	Sportsman 500 EFI Touring	499cc	2008	2010			
	Sportsman 500 EFI Touring			2009	2009		
	Sportsman 500 EFI X2	499cc	2006	2009			
	Sportsman 500 EFI X2	499cc	2007	2009			
	Sportsman 500 EFI X2 Deluxe	499cc	2007	2007			
	Sportsman 500 EFI X2 Deluxe			2008	2009		
	Sportsman 500 Forest Tracker EFI			2011	2011		
	Sportsman 500 Forest Tracker EFI			2011	2013		
	Sportsman 500 HO	455cc	2013	2013			
	Sportsman 500 HO	498cc	2011	2012			
	Sportsman 500 HO	498cc	2012	2013			
	Sportsman 500 HO	499cc	2001	2002			
	Sportsman 500 HO	499cc	2001	2010			
	Sportsman 500 HO	499cc	2001	2011			
	Sportsman 500 HO	499cc	2003	2004			
	Sportsman 500 HO	499cc	2008	2011			
	Sportsman 500 HO	499cc	2009	2011			
	Sportsman 500 HO EFI			2008	2008		
	Sportsman 500 HO Polaris Pursuite	498cc	2012	2012			
	Sportsman 500 HO RSE	499cc	2001	2001			
	Sportsman 500 HO Touring	498cc	2010	2011			
	Sportsman 500 HO Touring	498cc	2010	2013			
	Sportsman 500 HO Touring	498cc	2012	2012			
	Sportsman 500 RSE	499cc	1999	2000			
	Sportsman 500 Swedish	499cc	1996	1997			
	Sportsman 500 Swedish	499cc	1998	1998			
	Sportsman 500 Swedish			1996	1998		
	Sportsman 500 Touring Quad EFI			2008	2009		
	Sportsman 500 Tractor EFI			2009	2010		
Sportsman 500 Tractor EFI Forest			2011	2011			
Sportsman 500 Tractor Forest			2012	2014			
Sportsman 500 X			2002	2002			
Sportsman 500 X2			2006	2006			
Sportsman 500 X2			2006	2009			
Sportsman 550	549cc	2011	2013				
Sportsman 550 EFI	549cc	2010	2011				

BOBINE ACCENSIONE IGNITION COILS	REGOLATORI & RADDRIZZATORI REGULATORS & RECTIFIERS	KIT RIPARAZIONE REPAIR KIT	INTERRUTTORI SOLENOIDI SOLENOID SWITCH	MOTORINI AVVIAMENTO STARTER	INGRANAGGI AVVIAMENTO STARTER DRIVES	KIT RIPARAZIONE MOTORINI AVVIAMENTO STARTER REPAIR KIT	STATORI STATORS
CPS27				19031N			
CPS27							
CPS27							
CPS27							
	S1032						
	S1032						
CPS27							
CPS27							
						79-85112	
	S1032						
	S1019N						
		79-85107					
				17628N			
				19572N			
			67-777				
			67-777				
			67-777				
			67-777				
			67-777				
			67-777				
			67-777				
			67-777				
			67-777				
			67-777				
			67-777				
			67-777				
			67-777				
			67-777				
			67-777				
			67-777				
			67-777				
			67-777				
			67-777				
			67-777				
			67-777				
			67-777				
			67-777				
			67-777				
			67-777				
			67-777				
			67-777				
			67-777				
			67-777				
			67-777				
			67-777				
			67-777				
			67-777				
			67-777				
			67-777				

ELECTRIC PARTS ATV - UTV

MARCA MAKE	MODELLO MODEL	CC CC	DA FROM	A TO	ALTERNATORE ALTERNATORE	CENTRALINA CDI	GENERATORE GENERATOR	
POLARIS	Sportsman 550 EFI Touring w/ EPS	549cc	2010	2010				
	Sportsman 550 EFI Touring w/ EPS	549cc	2010	2014				
	Sportsman 550 EFI w/ EPS	549cc	2010	2011				
	Sportsman 550 EFI XP	549cc	2009	2009				
	Sportsman 550 EFI XP w/ EPS	549cc	2009	2009				
	Sportsman 550 EFI XP w/ EPS			2015	2015			
	Sportsman 550 EPS	549cc	2011	2014				
	Sportsman 550 EPS Browning LE	549cc	2011	2014				
	Sportsman 550 EPS Orange Madness LE	549cc	2012	2012				
	Sportsman 550 EPS Stealth Black LE	549cc	2013	2013				
	Sportsman 550 Touring EPS	549cc	2011	2014				
	Sportsman 550 X2	549cc	2010	2010				
	Sportsman 550 X2	549cc	2010	2014				
	Sportsman 550 X2 EPS	549cc	2014	2014				
	Sportsman 570	--L 567cc -cid		2014	2014			
	Sportsman 570	567cc		2014	2016			
	Sportsman 570 EPS	--L 567cc -cid		2014	2015			
	Sportsman 570 EPS	567cc		2014	2016			
	Sportsman 570 SP	567cc		2015	2015			
	Sportsman 570 Touring	--L 567cc -cid		2014	2015			
	Sportsman 570 Touring SP	567cc		2015	2015			
	Sportsman 570 X2 EPS	--L 567cc -cid		2015	2015			
	Sportsman 570 X2 EPS	567cc		2015	2016			
	Sportsman 600	597cc		2003	2004			
	Sportsman 600	597cc		2003	2005			
	Sportsman 600	597cc		2004	2004			
	Sportsman 6x6			2009	2009			
	Sportsman 700	683cc		2002	2006			
	Sportsman 700	683cc		2003	2004			
	Sportsman 700	683cc		2004	2004			
	Sportsman 700 EFI	683cc		2004	2004			
	Sportsman 700 EFI	683cc		2004	2007			
	Sportsman 700 EFI	683cc		2005	2006			
	Sportsman 700 EFI	683cc		2007	2007			
	Sportsman 700 EFI X2	683cc		2008	2008			
	Sportsman 700 MV	683cc		2006	2010			
	Sportsman 700 Twin Mossy Oak			2004	2004			
	Sportsman 700 Twin Mossy Oak			2004	2006			
	Sportsman 800 6x6 Big Boss	760cc		2012	2014			
	Sportsman 800 EFI	760cc		2005	2006			
	Sportsman 800 EFI	760cc		2005	2014			
	Sportsman 800 EFI	760cc		2007	2014			
	Sportsman 800 EFI 6x6 Big Boss	760cc		2009	2011			
	Sportsman 800 EFI 6x6 Big Boss			2012	2014			
	Sportsman 800 EFI Deluxe	760cc		2007	2007			
Sportsman 800 EFI HO	760cc		2008	2009				
Sportsman 800 EFI HO	760cc		2008	2010				
Sportsman 800 EFI Touring	760cc		2008	2009				
Sportsman 800 EFI X2	760cc		2007	2009				
Sportsman 800 EFI X2 Deluxe	760cc		2007	2007				

BOBINE ACCENSIONE IGNITION COILS	REGOLATORI & RADDRIZZATORI REGULATORS & RECTIFIERS	KIT RIPARAZIONE REPAIR KIT	INTERRUTTORI SOLENOIDI SOLENOID SWITCH	MOTORINI AVVIAMENTO STARTER	INGRANAGGI AVVIAMENTO STARTER DRIVES	KIT RIPARAZIONE MOTORINI AVVIAMENTO STARTER REPAIR KIT	STATORI STATORS
			67-777				
			67-777				
			67-777				
			67-777				
			67-777				
			67-777				
			67-777				
			67-777				
			67-777				
			67-777				
			67-777				
			67-777				
CPS27							
CPS27							
		79-85107					
		79-85107					
CPS27							
CPS27							
CPS27							
CPS27							
CPS27							
CPS27							
						79-85108	
CPS27							
CPS27							
				19639N			
				18755N		79-85123	
	YM1044N			18754N			
	YM1032N						
	YM1032N						
				18754N			
	YMN1008N						
				18340N			
				18340N			
	YM1033N			18755N		79-85123	
				18754N			
	YM1043N			18753N			
				18753N			
	YMN1008N						
			67-771				
				18754N			
	YM1033N		67-771	18753N			
	YM1033N		67-771	18753N			
	YM1043N			18753N			
				19639N			
				19639N			
	YM1033N						
				19639N			

ELECTRIC PARTS
ATV - UTV

ELECTRIC PARTS ATV - UTV

MARCA MAKE	MODELLO MODEL	CC CC	DA FROM	A TO	ALTERNATORE ALTERNATORE	CENTRALINA CDI	GENERATORE GENERATOR
POLARIS	Sportsman 800 Forest		2012	2012			
	Sportsman 800 HO EFI Military	760cc	2008	2008			
	Sportsman 850	850cc	2015	2015			
	Sportsman 850 EFI Touring EPS	850cc	2010	2011			
	Sportsman 850 EFI X2	850cc	2011	2011			
	Sportsman 850 EFI XP	850cc	2009	2011			
	Sportsman 850 EFI XP w/ EPS	850cc	2009	2014			
	Sportsman 850 HO Touring EPS	850cc	2012	2014			
	Sportsman 850 HO Touring EPS Bronze Mist LE	850cc	2012	2014			
	Sportsman 850 HO Touring EPS Sunset Red LE	850cc	2013	2013			
	Sportsman 850 HO XP	850cc	2012	2013			
	Sportsman 850 HO XP EPS	850cc	2012	2014			
	Sportsman 850 HO XP EPS	850cc	2015	2015			
	Sportsman 850 HO XP EPS Browning LE	850cc	2012	2014			
	Sportsman 850 HO XP EPS Orange Madness LE	850cc	2012	2012			
	Sportsman 850 HO XP EPS Pearl White LE	850cc	2014	2014			
	Sportsman 850 HO XP EPS Stealth Black LE	850cc	2013	2013			
	Sportsman 850 Touring SP	850cc	2015	2015			
	Sportsman 90	89cc	2001	2006			
	Sportsman 90	89cc	2007	2014			
	Sportsman ACE	325cc	2014	2014			
	Sportsman ACE 570	--L 567cc -cid	2015	2015			
	Sportsman ACE 570 SP	--L 567cc -cid	2015	2015			
	Sportsman ETX	325cc	2015	2015			
	Sportsman Forest 500	498cc	2011	2012			
	Sportsman Forest 500	498cc	2013	2013			
	Sportsman Forest 550	498cc	2011	2014			
	Sportsman Forest 800	498cc	2012	2013			
	Sportsman Forest 800 6x6	498cc	2012	2014			
	Sportsman Forest 850	498cc	2011	2014			
	Sportsman Forest 850	850cc	2014	2014			
	Sportsman Forest Tractor 500	498cc	2011	2011			
	Sportsman Forest Tractor 500	498cc	2011	2012			
	Sportsman MV7	683cc	2005	2005			
	Sportsman X2 700 EFI		2008	2008			
	Sportsman X2 800 EFI		2007	2009			
	Sportsman XP 550		2009	2009			
	Sportsman XP 550 EPS		2009	2014			
	Sportsman XP 550 Touring EPS		2012	2012			
	Sportsman, RZR & Ranger 570	570cc	2015	2015			
	Trail Blazer 250	244cc	1990	2006			
	Trail Blazer 250	244cc	1999	2003			
	Trail Blazer 250		1996	1997			
	Trail Blazer 330	329cc	2008	2011			
	Trail Blazer 330	329cc	2008	2013			
	Trail Blazer 330	329cc	2010	2013			
	Trail Blazer 400	400cc	2003	2003			
Trail Boss 250	244cc	1991	1999				
Trail Boss 250		1988	1999				
Trail Boss 250		1989	1997				

BOBINE ACCENSIONE	REGOLATORI & RADDRIZZATORI	KIT RIPARAZIONE	INTERRUTTORI SOLENOIDI	MOTORINI AVVIAMENTO	INGRANAGGI AVVIAMENTO	KIT RIPARAZIONE MOTORINI AVVIAMENTO	STATORI
IGNITION COILS	REGULATORS & RECTIFIERS	REPAIR KIT	SOLENOID SWITCH	STARTER	STARTER DRIVES	STARTER REPAIR KIT	STATORS
				19639N			
	YM1033N						
	YM1033N						27-7024
	YM1033N			18757N			
	YM1033N			18757N			
				18757N			
	YM1033N						
	YM1033N						
				18757N			
				18756N			27-7021
			67-771	18757N			
				18756N		79-85112	
	YM1043N						27-7026
	YM1032N						27-7011
				18758N		79-85105	
	YM1041N						
							27-7038
	YM1033N			18757N			
	YM1043N						
				18756N			
							27-7026
	YM1032N						
							27-7011
						79-85105	
				18758N			
	YM1033N						
							27-7021
							27-7021
							27-7011
	YMN1008N			18756N			
						79-85105	
	YM1043N						
				18756N			
							27-7026
	YMN1008N						27-7011
	YM1041N						27-7021
	YMN1008N						
				18758N			
	YM1033N						
	YMN1008N						
				18758N		79-85105	
							27-7038
	YM1033N						
						79-85105	
				18758N			
						79-85105	
	YM1033N						
				18758N			
						79-85105	
				18758N			

ELECTRIC PARTS ATV - UTV

MARCA MAKE	MODELLO MODEL	CC CC	DA FROM	A TO	ALTERNATORE ALTERNATORE	CENTRALINA CDI	GENERATORE GENERATOR
POLARIS	Trail Boss 250 2x4	244cc	1988	1993			
	Trail Boss 250 4x4	244cc	1987	1993			
	Trail Boss 250R/ES	244cc	1985	1988			
	Trail Boss 300 2x4	300cc	1995	1995			
	Trail Boss 300 4x4	300cc	1995	1995			
	Trail Boss 325	325cc	1999	1999			
	Trail Boss 325	325cc	2000	2002			
	Trail Boss 330	329cc	2003	2011			
	Trail Boss 330	329cc	2003	2013			
	Trail Boss 330	329cc	2007	2013			
	Trail Boss 330	329cc	2010	2013			
	Trail Boss 350L 2x4	352cc	1990	1993			
	Trail Boss 350L 4x4	352cc	1990	1993			
	Worker 335	335cc	1999	1999			
	Worker 500	499cc	1999	2001			
	X2 500 EFI	499cc	2007	2007			
	Xpedition 325	325cc	2000	2002			
	Xpedition 425	425cc	2000	2002			
	Xplorer 250 4x4	244cc	2000	2002			
	Xplorer 300 4x4	283cc	1996	2001			
	Xplorer 300 4x4			1996	1997		
	Xplorer 300 4x4			1996	2000		
	Xplorer 400 4x4	400cc	1995	1997			
	Xplorer 400 4x4	400cc	1995	2001			
	Xplorer 400 4x4	400cc	1998	2001			
	Xplorer 400 4x4			1995	2002		
	Xplorer 400L	400cc	2002	2002			
	Xplorer 500 4x4	499cc	1997	1997			
	Xpress 300	283cc	1996	1999			
	Xpress 300	283cc	1997	1997			
	Xpress 300			1996	1997		
	Xpress 400L	400cc	1996	1997			
	REDCAT MOTORS	DPX 250	244cc	2005	2006		
FX 250		249cc	2005	2006			
KMZ 150		149cc	2005	2005			
MPX 110		107cc	2006	2007			
RFX 110MKII		108cc	2005	2005			
SFX 110		108cc	2005	2005			
VX 110		107cc	2005	2006			
SEA-DOO	VX 150	147cc	2005	2006			
	3D DI		2004	2004			
	GTI LE	718cc	2003	2004			
	Expedition TUV V-800	799cc	2007	2009			
	Legend Touring V-800	799cc	2007	2009			
	Legend V-800		2007	2008			
	Scandic Super Wide Track V-800		2007	2008			
	Skandic Tundra V-800		2007	2009			
	Skandic V-800 SWT		2011	2012			
	SUNL SUZUKI	4 Wheeler					
500 KingQuad AXi		454cc	2010	2010			

BOBINE ACCENSIONE	REGOLATORI & RADDRIZZATORI	KIT RIPARAZIONE	INTERRUTTORI SOLENOIDI	MOTORINI AVVIAMENTO	INGRANAGGI AVVIAMENTO	KIT RIPARAZIONE MOTORINI AVVIAMENTO	STATORI
IGNITION COILS	REGULATORS & RECTIFIERS	REPAIR KIT	SOLENOID SWITCH	STARTER	STARTER DRIVES	STARTER REPAIR KIT	STATORS
	YM1033N			18759N			
				18756N			
	YM1033N						27-7020
				18759N			
	YM1032N						
							27-7011
				18756N			
	YMN1008N					79-85105	
	YM1033N						27-7020
				18759N			
				18759N			
				19499N			
				19499N			
				18759N			
	YM1033N						27-7020
	YM1033N			18759N			27-7020
							27-7020
							27-7020
	YM1033N						27-7020
	YM1033N						27-7020
	YM1033N			18759N			27-7020
							27-7020
	YM1044N			18340N			
				19500N			27-7037
				19500N			27-7037
	YMN1008N						27-7022
				18759N			
	YM1033N						27-7014
				18759N			
	YM1033N		67-771				
				18888N			
							27-7037
				19500N			
				18888N			
							27-7037
				19500N			
				19500N			
							27-7037
							27-7037
				18888N			
				18888N			
				18888N			
				18888N			
				18340N			
	YM1044N						
	YM1044N			18340N			
	YM1044N			18340N			
				18756N			

ELECTRIC PARTS ATV - UTV

MARCA MAKE	MODELLO MODEL	CC CC	DA FROM	A TO	ALTERNATORE ALTERNATORE	CENTRALINA CDI	GENERATORE GENERATOR	
SUZUKI	DL1000 V-Strom	996cc	2002	2006				
	DR-Z400	398cc	2000	2004				
	DR-Z400E	398cc	2000	2007				
	DR-Z400S	398cc	2000	2015				
	DR-Z400SM	398cc	2005	2015				
	DR650S	644cc	1992	1993				
	DR650SE	644cc	1996	2013				
	DR650SE	644cc	1998	1999				
	DR650SES	644cc	1992	1995				
	DS80			1978	2000			
	GN250	249cc		1982	1988			
	GS1150E	1168cc		1984	1986			
	GS1150ES	1168cc		1985	1985			
	GS450E			1983	1988			
	GS450G			1982	1983			
	GS450GA			1983	1985			
	GS450L	448cc		1985	1988			
	GS450L			1983	1988			
	GS450TX			1983	1983			
	GS500	487cc		1989	2002			
	GS500F	487cc		2004	2009			
	GS550E	549cc		1983	1986			
	GS550ES	549cc		1983	1986			
	GS550L	549cc		1983	1986			
	GSX-R600	--L 599cc -cid		1997	2000			
	GSX-R750	--L 749cc -cid		1996	1997			
	GSX-R750	749cc		1988	1992			
	GSX250E			1982	1983			
	GSX400E			1982	1982			
	GSX600F Katana	599cc		1988	1997			
	GSX750F Katana	748cc		1989	1997			
	GV1200 Madura	1165cc		1985	1986			
	GV1400 Cavalcade	1360cc		1986	1988			
	GV700GL Madura	698cc		1985	1986			
	JR80			2001	2004			
	LT-4WD QuadRunner 250	249cc		1987	1998			
	LT-4WDX King Quad 250	249cc		1996	1998			
	LT-A400 Eiger 2x4 Auto	376cc		2002	2007			
	LT-A400F Eiger 4x4 Auto	376cc		2002	2007			
	LT-A400F KingQuad AS	376cc		2008	2015			
	LT-A450X KingQuad AXi 4x4	454cc		2007	2010			
	LT-A500 KingQuad AXi	493cc		2011	2014			
	LT-A500 KingQuad AXi Power Steering	493cc		2009	2014			
	LT-A500F QuadMaster	493cc		2000	2001			
	LT-A500F Vinson 500 4x4 Auto	493cc		2002	2007			
LT-A700X KingQuad 4x4	695cc		2005	2007				
LT-A750 KingQuad AXi Power Steering	--L 722cc -cid		2011	2014				
LT-A750X KingQuad AXi 4x4	--L 722cc -cid		2011	2014				
LT-A750X KingQuad AXi 4x4	722cc		2008	2009				
LT-F160 QuadRunner	158cc		1991	2001				

BOBINE ACCENSIONE	REGOLATORI & RADDRIZZATORI	KIT RIPARAZIONE	INTERRUTTORI SOLENOIDI	MOTORINI AVVIAMENTO	INGRANAGGI AVVIAMENTO	KIT RIPARAZIONE MOTORINI AVVIAMENTO	STATORI
IGNITION COILS	REGULATORS & RECTIFIERS	REPAIR KIT	SOLENOID SWITCH	STARTER	STARTER DRIVES	STARTER REPAIR KIT	STATORS
				18753N			
				18753N			
							27-7018
							27-7012
				18761N			
				18761N			
				18761N			
				19200N			
							27-7041
	YM1034N			19200N			
	YM1034N			19200N			
				19200N			
				19200N			
				18754N			
				18754N			
				18754N			
				18888N			
				18888N			
				18888N			
				18888N			
				18888N			
				18888N			
				18888N			
				18888N			
				18888N			
				18888N			
				18888N			
				18888N			
				18888N			
				18888N			
	YM1034N			18759N			
				18759N			
	YM1034N			18759N			
				18759N			
				18759N			
				18759N			
				18759N			
				18888N			
				18888N			
				18888N			
				18888N			
CPS27							
CPS27							
CPS27							
		79-85107					
				18757N			
			67-748	5776N-HD			
				10872N			
				10872N			
				19451N			

ELECTRIC PARTS
ATV - UTV

ELECTRIC PARTS ATV - UTV

MARCA MAKE	MODELLO MODEL	CC CC	DA FROM	A TO	ALTERNATORE ALTERNATORE	CENTRALINA CDI	GENERATORE GENERATOR
SUZUKI	LT-F160 QuadRunner	158cc	1991	2004			
	LT-F230	230cc	1986	1987			
	LT-F250 Ozark	249cc	2002	2012			
	LT-F250 Ozark	249cc	2002	2014			
	LT-F250 Ozark	250cc	2013	2014			
	LT-F250 QuadRunner	249cc	1988	2001			
	LT-F250 QuadRunner	249cc	1988	2002			
	LT-F250F QuadRunner 4x4	249cc	1999	2002			
	LT-F300F KingQuad 4x4	300cc	1999	2002			
	LT-F400 Eiger 2x4	376cc	2002	2007			
	LT-F400F Eiger 4x4	376cc	2002	2007			
	LT-F400F KingQuad FS	376cc	2008	2010			
	LT-F400F KingQuad FSi LE	376cc	2014	2014			
	LT-F4WDX King Quad 300	300cc	1991	1998			
	LT-F500F QuadRunner 4x4	493cc	1998	2002			
	LT-F500F Vinson 500 4x4	493cc	2003	2007			
	LT-F500F Vinson 500 4x4	493cc	2004	2007			
	LT-R450 QuadRacer	450cc	2006	2009			
	LT-V700F Twin Peaks 700 4x4	697cc	2004	2005			
	LT-Z250 QuadSport Z	246cc	2004	2009			
	LT-Z250 QuadSport Z	246cc	2005	2009			
	LT-Z400			2003	2008		
	LT-Z400 QuadSport Z	398cc		2003	2009		
	LT-Z400 QuadSport Z			2003	2008		
	LT-Z400 QuadSport Z LE			2012	2012		
	LT-Z50 QuadSport	49cc		2006	2009		
	LT-Z90 QuadSport	90cc		2007	2014		
	LT160	158cc		2003	2004		
	LT160E	158cc		1989	1992		
	LT185	185cc		1984	1987		
	LT230E QuadRunner	230cc		1987	1993		
	LT230GE	230cc		1985	1986		
	LT250EF	249cc		1985	1986		
	LT80 QuadSport	82cc		1987	2006		
	QUV620F	620cc		2005	2005		
	RG125FU Gamma II			1992	1994		
	RG125U Wolf			1992	1992		
	RGV250			1988	1996		
	RMX250			1989	1999		
	SV650	654cc		1999	2002		
	SV650S	654cc		1999	2002		
	TS125			1989	1994		
TS50			1984	1994			
TU250X	249cc		2009	2011			
VL1500 Intruder	1462cc		1998	2004			
VL800 Intruder Volusia	805cc		2001	2004			
VZ800 Marauder	805cc		1997	2003			
THOMAS EQUIPMENT	T95		1994	2007	12650N		
TORO	212-6 Tractor		1987	1988			
	Greensmaster 3050		1997	2009			

ELECTRIC PARTS ATV - UTV

MARCA MAKE	MODELLO MODEL	CC CC	DA FROM	A TO	ALTERNATORE ALTERNATORE	CENTRALINA CDI	GENERATORE GENERATOR
TORO	Greensmaster 3100		1992	2009			
	Greensmaster 3150		2002	2009			
	Grounds Pro 2000		1998	1999			
	Infield Pro 3040		2006	2009			
	Infield Pro 5040		2006	2009			
	Sand Pro 2020		1997	2009			
	Sand Pro 3020		1997	2006			
	Sand Pro 5000		1994	1997			
	Sand Pro 5020		1998	2006			
	Twister 1400	16HP	2002	2002			
	Twister 1400 UTV		2002	2002			
	Twister 1600	16HP	2002	2002			
	Twister 1600 UTV		2002	2008			
	Workman 3100	23HP	1994	1994			
	Workman 3200		1993	2001	12855N		
	Workman 4200		1995	2001	12855N		
	Z287L Z Master		2001	2003			
	Z580 Z Master		2008	2009			
	Z587L Z Master		2004	2006			
	Z589 Z Master		2007	2007			
VENTO VICTORY	GY6						
	Arlen Ness Jackpot	1634cc	2006	2008			
	Arlen Ness Vision	1670cc	2009	2010			
	Arlen Ness Vision	1731cc	2011	2013			
	Boardwalk	1731cc	2013	2013			
	Cory Ness Jackpot	1634cc	2008	2008			
	Cory Ness Jackpot	1731cc	2009	2010			
	Cross Country	1731cc	2010	2014			
	Cross Country 8-Ball	1731cc	2014	2014			
	Cross Country Tour	1731cc	2014	2014			
	Cross Roads	1731cc	2010	2012			
	Cross Roads		2013	2013			
	Hammer	1634cc	2005	2008			
	Hammer	1731cc	2009	2011			
	Hammer 8-Ball	1731cc	2010	2014			
	Hammer S	1634cc	2007	2008			
	Hammer S	1731cc	2009	2012			
	High-Ball	1731cc	2012	2014			
	Jackpot	1731cc	2014	2014			
	Jackpot		2006	2010			
	Judge	1731cc	2013	2013			
	Kingpin	1507cc	2004	2005			
	Kingpin	1634cc	2006	2010			
	Kingpin	1731cc	2011	2012			
	Kingpin 8-Ball	1634cc	2008	2010			
	Kingpin 8-Ball	1731cc	2011	2011			
	Kingpin Low	1634cc	2009	2009			
	Kingpin Tour	1634cc	2007	2009			
	Kingpin Tour		2004	2006			
	Touring Cruiser	1507cc	2004	2006			

ELECTRIC PARTS ATV - UTV

MARCA MAKE	MODELLO MODEL	CC CC	DA FROM	A TO	ALTERNATORE ALTERNATORE	CENTRALINA CDI	GENERATORE GENERATOR
VICTORY	Vegas	1507cc	2004	2005			
	Vegas	1634cc	2006	2010			
	Vegas	1731cc	2011	2012			
	Vegas		2013	2013			
	Vegas 8-Ball	1507cc	2005	2005			
	Vegas 8-Ball	1634cc	2006	2010			
	Vegas 8-Ball	1731cc	2011	2013			
	Vegas Jackpot	1634cc	2006	2008			
	Vegas Jackpot	1731cc	2009	2013			
	Vegas Low	1634cc	2008	2009			
	Vision 8-Ball	1731cc	2010	2011			
	Vision Street	1731cc	2008	2009			
	Vision Street Premium	1731cc	2008	2009			
	Vision Tour	1731cc	2008	2014			
	Vision Tour 10th Anniv.	1731cc	2009	2009			
	Vision Tour Comfort	1731cc	2008	2009			
	Vision Tour Comfort		2010	2010			
	Vision Tour Premium	1731cc	2008	2009			
	Vision Tour Premium		2010	2010			
	YAMAHA	BL125 Beluga		1985	1987		
DT125 LC			1982	1988			
FZR600			1989	1993			
FZR600R		599cc	1989	1999			
G16			1996	1996			15422N
G17			1996	1996			15422N
G18			1996	1996			15422N
G19			1996	1996			15422N
G20			1996	1996			15422N
G21			1996	1996			15422N
G22			1996	1996			15422N
RD125			1982	1989			
RD80			1982	1984			
RX100			1985	1996			
SA50 Passola			1980	1984			
T50 Townmate			1986	1986			
T80 Townmate			1983	1996			
XJ600S Seca II		599cc	1992	1998			
XT125R			2005	2007			
XT125X Supermotard			2005	2007			
XT250		249cc	2008	2015			
YFA-1 Breeze125		124cc	1989	2004			
YFA-1 Breeze125		124cc	1997	2004			
YFB250 Timberwolf 2x4		230cc	1992	1998			
YFB250 Timberwolf 2x4		230cc	1994	1996			
YFB250FW Timberwolf 4x4		230cc	1994	1996			
YFB250FW Timberwolf 4x4		230cc	1994	2000			
YFB250FW Timberwolf 4x4	230cc	1997	2000				
YFM100 Champ	99cc	1987	1991				
YFM100 Moto		1985	1989				
YFM125 Grizzly	124cc	2004	2013				

BOBINE ACCENSIONE	REGOLATORI & RADDRIZZATORI	KIT RIPARAZIONE	INTERRUTTORI SOLENOIDI	MOTORINI AVVIAMENTO	INGRANAGGI AVVIAMENTO	KIT RIPARAZIONE MOTORINI AVVIAMENTO	STATORI
IGNITION COILS	REGULATORS & RECTIFIERS	REPAIR KIT	SOLENOID SWITCH	STARTER	STARTER DRIVES	STARTER REPAIR KIT	STATORS
				18667N			
				18667N			
				18667N			
			66-8210		54-8244		
	KW2056		66-8210		54-8244		
	KW2056		66-8210		54-8244		
			66-8210		54-8244		
			66-8210		54-8244		
			66-8210		54-8244		
			66-8210		54-8244		
			66-8210		54-8244		
			66-8210		54-8244		
			66-8210	18404N	54-8244		
			66-8210	18404N	54-8244		
	JDR6304		66-8210	18404N	54-8244		
				5776N			
	JDR6304		66-8210	18404N	54-8244		
	KW2056		66-8210		54-8244		
			66-8210	18404N	54-8244		
			66-8210	18404N	54-8244		
			66-8210	18404N	54-8244		
			66-8210	18404N	54-8244		
			66-8210	18404N	54-8244		
				16094N			
				16094N			
				19119N			
				19119N			
				19119N			
			66-8210		54-8244		
				5776N			
			66-8210		54-8244		
			66-8210		54-8244		
			66-8210		54-8244		
			66-8210		54-8244		
			66-8210		54-8244		
			66-8210		54-8244		
			66-8210	5776N			
			66-8210	5776N			
			66-8210	18404N	54-8244		
			66-8210		54-8244		
			66-8210		54-8244		
			66-8210		54-8244		
			66-8210		54-8244		
			66-8210		54-8244		
			66-8210		54-8244		
			66-8210		54-8244		
			66-8210		54-8244		
			66-8210		54-8244		
			66-8210		54-8244		
			66-8210		54-8244		
			66-8210		54-8244		
			66-8210		54-8244		
			66-8210		54-8244		
			66-8210		54-8244		
			66-8210		54-8244		
			66-8210		54-8244		
			66-8210		54-8244		

ELECTRIC PARTS ATV - UTV

MARCA MAKE	MODELLO MODEL	CC CC	DA FROM	A TO	ALTERNATORE ALTERNATORE	CENTRALINA CDI	GENERATORE GENERATOR
YAMAHA	YFM200 Moto-4	198cc	1985	1989			
	YFM225 Moto-4	223cc	1986	1988			
	YFM250 Bear Tracker	230cc	1999	2002			
	YFM250 Bear Tracker	230cc	2000	2000			
	YFM250 Bear Tracker	230cc	2000	2004			
	YFM250 Bear Tracker	230cc	2003	2004			
	YFM250 Big Bear	230cc	2007	2009			
	YFM250 Bruin	230cc	2005	2006			
	YFM250 Moto-4	230cc	1989	1991			
	YFM250 Raptor	249cc	2008	2013			
	YFM250 Raptor SE	249cc	2008	2008			
	YFM250 Raptor SE	249cc	2008	2012			
	YFM250 Raptor SE Custom	249cc	2008	2008			
	YFM250R Raptor	249cc	2011	2011			
	YFM250R Raptor	249cc	2011	2013			
	YFM250X Bear Tracker	230cc	2001	2004			
	YFM350 Bruin Auto 2x4	348cc	2004	2006			
	YFM350 Grizzly 4x4 Auto	348cc	2007	2014			
	YFM350 Grizzly Auto	348cc	2007	2012			
	YFM350 Grizzly Auto	348cc	2007	2014			
	YFM350 Grizzly IRS 4x4 Auto	348cc	2007	2011			
	YFM350 Grizzly IRS 4x4 Auto	348cc	2007	2012			
	YFM350 Raptor	348cc	2004	2013			
	YFM350 Wolverine	348cc	2006	2009			
	YFM350ER Moto-4	348cc	1987	1995			
	YFM350ER Moto-4	348cc	1990	1994			
	YFM350ER Moto-4	348cc	1995	1995			
	YFM350F Wolverine 4x4	--L 348cc -cid	2002	2005			
	YFM350F Wolverine 4x4	--L 348cc -cid	2003	2005			
	YFM350F Wolverine 4x4	348cc	1995	2005			
	YFM350FA Bruin Auto 4x4	348cc	2004	2006			
	YFM350FW Big Bear 4x4	348cc	1987	1994			
	YFM350FW Big Bear 4x4	348cc	1987	1999			
	YFM350FW Big Bear 4x4	348cc	1990	1994			
	YFM350FW Big Bear 4x4	348cc	1995	1996			
	YFM350FW Big Bear 4x4	348cc	1995	1997			
	YFM350FW Big Bear 4x4	348cc	1996	1999			
	YFM350FW Big Bear 4x4	348cc	1997	1999			
	YFM350R Raptor 350	348cc	2004	2014			
	YFM350R Raptor 350		2004	2013			
	YFM350RSE Raptor 350	348cc	2005	2007			
	YFM350U Big Bear 2x4	348cc	1996	1998			
	YFM350U Big Bear 2x4	348cc	1996	1999			
	YFM350U Big Bear 2x4	348cc	1999	1999			
	YFM350X Warrior	348cc	1987	1995			
	YFM350X Warrior	348cc	1987	2004			
	YFM350X Warrior	348cc	1990	1995			
	YFM350X Warrior	348cc	1996	2001			
	YFM350X Warrior	348cc	2002	2004			
	YFM35FX Wolverine	348cc	1995	2000			

BOBINE ACCENSIONE	REGOLATORI & RADDRIZZATORI	KIT RIPARAZIONE	INTERRUTTORI SOLENOIDI	MOTORINI AVVIAMENTO	INGRANAGGI AVVIAMENTO	KIT RIPARAZIONE MOTORINI AVVIAMENTO	STATORI
IGNITION COILS	REGULATORS & RECTIFIERS	REPAIR KIT	SOLENOID SWITCH	STARTER	STARTER DRIVES	STARTER REPAIR KIT	STATORS
			66-8210		54-8244		
			66-8210		54-8244		
			66-8210		54-8244		
			66-8210		54-8244		
			66-8210		54-8244		
			66-8210		54-8244		
			66-8210		54-8244		
			66-8210		54-8244		
			66-8210		54-8244		
			66-8210		54-8244		
			66-8210	18404N	54-8244		
			66-8210	18404N	54-8244		
			66-8210	18404N	54-8244		
			66-8210	18404N	54-8244		
			66-8210	18404N	54-8244		
			66-8210	18404N	54-8244		
			66-8210	18404N	54-8244		
			66-8210	18404N	54-8244		
			66-8210	18450N			
			66-8210	18450N			
			66-8210	18450N			
				18533N			
				18533N			
				18533N			
				18533N			
	KW2056			18511N			
	KW2056			18511N			
				18511N			
			66-8210	18512N	54-8244		
			66-8210	18512N	54-8244		
	KW2056		66-8210	18512N	54-8244		
	KW2056		66-8210	18512N	54-8244		
				18629N			
				18629N			
				18629N			
				18629N			
				18629N			
				16011N			
				18629N			
				16011N			
				18629N			
				16011N			
				18630AN			
				18630AN			
				18630AN			
				10706N			
				18419N			
				18565N			

ELECTRIC PARTS
ATV - UTV

ELECTRIC PARTS ATV - UTV

MARCA MAKE	MODELLO MODEL	CC CC	DA FROM	A TO	ALTERNATORE ALTERNATORE	CENTRALINA CDI	GENERATORE GENERATOR
YAMAHA	YFM35FX Wolverine		2004	2005			
	YFM35FX Wolverine		2006	2009			
	YFM400 Big Bear 2x4	386cc	2000	2001			
	YFM400 Big Bear 2x4	386cc	2000	2004			
	YFM400 Big Bear 2x4	386cc	2000	2009			
	YFM400 Big Bear 2x4	386cc	2002	2004			
	YFM400 Big Bear 2x4			2005	2009		
	YFM400 Big Bear 4x4	386cc	2000	2006			
	YFM400 Big Bear 4x4	386cc	2000	2008			
	YFM400 Big Bear 4x4	386cc	2002	2008			
	YFM400 Big Bear 4x4			2007	2008		
	YFM400 Big Bear 4x4			2009	2012		
	YFM400 Big Bear IRS 4x4	386cc	2007	2012			
	YFM400 Grizzly 4x4 Auto	401cc	2007	2008			
	YFM400A Kodiak	401cc	2000	2002			
	YFM400A Kodiak	401cc	2000	2004			
	YFM400A Kodiak	401cc	2003	2004			
	YFM400F Kodiak 4x4	401cc	1993	1995			
	YFM400F Kodiak 4x4	401cc	1993	1998			
	YFM400F Kodiak 4x4	401cc	1993	2003			
	YFM400F Kodiak 4x4	401cc	1996	1999			
	YFM400F Kodiak 4x4	401cc	1999	1999			
	YFM400F Kodiak 4x4	401cc	2000	2006			
	YFM400F Kodiak 4x4	401cc	2004	2006			
	YFM450 Grizzly 4x4 Auto	421cc	2007	2008			
	YFM450 Grizzly 4x4 Auto	421cc	2011	2014			
	YFM450 Grizzly 4x4 Auto EPS	421cc	2011	2014			
	YFM450 Grizzly 4x4 Auto IRS	421cc	2009	2010			
	YFM450DAE Grizzly 450 4WD Hunting	449cc	2014	2014			
	YFM450F Kodiak Auto 4x4	421cc	2003	2006			
	YFM450FG Grizzly 450 4WD	421cc	2007	2014			
	YFM450FGH Grizzly 450 4WD Hunter	449cc	2007	2013			
	YFM450FGH Grizzly 450 4WD Hunter			2007	2014		
	YFM450FGI Grizzly 450 4WD	449cc	2007	2014			
	YFM450FX Wolverine 4x4	421cc	2006	2010			
	YFM4FG Grizzly 400	421cc	2007	2008			
	YFM50 Raptor	49cc	2004	2008			
	YFM550 Grizzly FI 4x4 Auto	558cc	2009	2014			
	YFM550 Grizzly FI 4x4 Auto EPS	558cc	2009	2014			
	YFM600FW Grizzly 4x4	598cc	1998	1998			
	YFM600FW Grizzly 4x4	598cc	1998	2001			
	YFM600FW Grizzly 4x4	598cc	1999	2001			
	YFM660F Grizzly 4x4	660cc	2002	2008			
	YFM660F Grizzly 4x4	660cc	2004	2008		YMC1000	
	YFM660R Raptor	660cc	2001	2005			
	YFM700 Grizzly FI 4x4 Auto	--L 686cc -cid	2007	2012			
	YFM700 Grizzly FI 4x4 Auto	686cc	2007	2008			
YFM700 Grizzly FI 4x4 Auto	686cc	2009	2015				
YFM700 Grizzly FI 4x4 Auto EPS	--L 686cc -cid	2007	2015				
YFM700 Grizzly FI 4x4 Auto EPS	686cc	2007	2008				

BOBINE ACCENSIONE	REGOLATORI & RADDRIZZATORI	KIT RIPARAZIONE	INTERRUTTORI SOLENOIDI	MOTORINI AVVIAMENTO	INGRANAGGI AVVIAMENTO	KIT RIPARAZIONE MOTORINI AVVIAMENTO	STATORI
IGNITION COILS	REGULATORS & RECTIFIERS	REPAIR KIT	SOLENOID SWITCH	STARTER	STARTER DRIVES	STARTER REPAIR KIT	STATORS
				18565N			
				19451N			
	PL1005N						
	PL1005N						
				18648N			
				19451N			
							27-7067
	PL1005N						
				18648N			
				18648N			
				18648N			
			67-777	18648N			
			67-777	18648N			
				18648N			
				18648N			
				19487N			
				19487N			
				19487N			
							27-7067
				19487N			
				19487N			
				19487N			
				19487N			
				19487N			
	PL1013N						
	PL1013N						
	PL1013N						
	PL1013N						
	PL1013N						
	PL1013N						
	PL1013N						
	PL1013N						
	PL1013N						
	PL1013N						
				18648N			
	PL1013N						
	PL1013N						
	PL1013N						
	PL1013N						
	PL1013N						
	PL1013N						
	PL1013N						
				19881N			
							27-7067
							27-7067
				19881N			
				19487N			
				19487N			
				18565N			

ELECTRIC PARTS
ATV - UTV

ELECTRIC PARTS ATV - UTV

MARCA MAKE	MODELLO MODEL	CC CC	DA FROM	A TO	ALTERNATORE ALTERNATORE	CENTRALINA CDI	GENERATORE GENERATOR
YAMAHA	YFM700 Grizzly FI 4x4 Auto EPS	686cc	2009	2015			
	YFM700 Grizzly FI 4x4 Auto EPS SE	--L 686cc -cid	2014	2015			
	YFM700 Grizzly FI 4x4 Auto EPS SE	686cc	2009	2015			
	YFM700 Grizzly		2013	2015			
	YFM700 Raptor	686cc	2013	2014			
	YFM700R Raptor	686cc	2006	2015			
	YFM700R Raptor GYTR Edition	686cc	2007	2007			
	YFM700R Raptor SE	686cc	2007	2015			
	YFM80 Badger	79cc	1985	2001			
	YFM80 Badger	79cc	1997	2001			
	YFM80 Grizzly	79cc	2005	2008			
	YFM80W Raptor	79cc	2002	2008			
	YFP350 TerraPro	348cc	1988	1988			
	YFU1TW Pro Hauler Turf	229cc	1989	1989			
	YFU1W Pro Hauler	229cc	1989	1989			
	YFZ350 Banshee	347cc	1987	1994			
	YFZ350 Banshee	347cc	1995	2006			
	YFZ450	449cc	2004	2013			
	YFZ450 Bill Balance Edition	449cc	2006	2007			
	YFZ450 SE	449cc	2007	2008			
	YFZ450R	449cc	2009	2015			
	YFZ450R	449cc	2012	2018			
	YFZ450R SE	449cc	2009	2015			
	YFZ450X	449cc	2010	2011			
	YFZ450X Bill Balance	449cc	2010	2010			
	YFZ450X SE	449cc	2011	2011			
	YTM200 Tri-Moto	198cc	1983	1985			
	YTM200E Yamahauler	198cc	1983	1985			
	YTM225 Tri-Moto	223cc	1983	1986			
	YXC700DF Viking VI			2015	2015		
	YXC700DH Viking VI Hunter			2015	2015		
	YXC700PF Viking VI 700 EPS			2015	2015		
	YXC700PH Viking VI EPS Hunter			2015	2015		
	YXC700PS Viking EPS SE			2015	2015		
	YXM700 Viking FI 4x4	686cc		2014	2014		
	YXM700 Viking FI 4x4 EPS	686cc		2014	2015		
	YXM700 Viking FI 4x4 EPS with Suntop	686cc		2014	2015		
	YXM700 Viking FI 4x4 with Suntop	686cc		2014	2015		
	YXM700DF Viking			2015	2015		
	YXM700DH Viking Hunter			2014	2015		
	YXM700PF Viking EPS			2015	2015		
	YXM700PH Viking EPS Hunter			2014	2015		
	YXM700PS Viking EPS SE			2014	2015		
	YXR45F Rhino 450	449cc		2006	2009		
	YXR45F Rhino 450 Special Edition	421cc		2007	2008		
	YXR66F Rhino 660	660cc		2004	2007		
	YXR66F Rhino 660 Ducks Unlimited	660cc		2007	2007		
YXR66F Rhino 660 Exploring Edition	660cc		2006	2007			
YXR66F Rhino 660 Special Edition	660cc		2006	2007			
YXR66F Rhino 660 Sport Edition	660cc		2007	2007			

BOBINE ACCENSIONE	REGOLATORI & RADDRIZZAZORI	KIT RIPARAZIONE	INTERRUTTORI SOLENOIDI	MOTORINI AVVIAMENTO	INGRANAGGI AVVIAMENTO	KIT RIPARAZIONE MOTORINI AVVIAMENTO	STATORI
IGNITION COILS	REGULATORS & RECTIFIERS	REPAIR KIT	SOLENOID SWITCH	STARTER	STARTER DRIVES	STARTER REPAIR KIT	STATORS
	PL1015N						
	PL1015N						
	PL1015N						
	PL1013N						
				19487N			
	PL1015N						
	PL1013N						
	PL1013N						
	PL1013N						
	PL1013N						
							27-7067
	PL1015N						
	PL1015N						
				19487N			
	PL1015N						
	PL1013N						
	PL1013N						
			67-777	19487N			
							27-7067
				19487N			
				19487N			
							27-7067
				19487N			
	PL1005N						
	PL1005N						
	PL1005N						
	PL1005N						
							27-7067
							27-7067
				18629N			
			66-8210		54-8244		
				5776N			
				5776N			
				5776N			
				5776N			
				5776N			
				5776N			
				5776N			
				5776N			
				5776N			
				5776N			
				5776N-HD			
				5776N			
				5776N-HD			
				5776N			
				19617N			
			66-8210		54-8244		
			66-8210		54-8244		

ELECTRIC PARTS
ATV - UTV

ELECTRIC PARTS ATV - UTV

MARCA MAKE	MODELLO MODEL	CC CC	DA FROM	A TO	ALTERNATORE ALTERNATORE	CENTRALINA CDI	GENERATORE GENERATOR
YAMAHA	YXR700F Rhino 700 FI	686cc	2008	2013			
	YXR700F Rhino 700 FI Ducks Unlimited	686cc	2008	2009			
	YXR700F Rhino 700 FI Special Edition	686cc	2008	2013			
	YXR700F Rhino 700 FI Sport Edition	686cc	2008	2013			
	YZ125		1983	1989			
	YZ250		1983	1989			
	YZ80		1983	1983			
	YZF600R	599cc	1995	1999			
YZF600R	599cc	2000	2007				

BOBINE ACCENSIONE	REGOLATORI & RADDRIZZATORI	KIT RIPARAZIONE	INTERRUTTORI SOLENOIDI	MOTORINI AVVIAMENTO	INGRANAGGI AVVIAMENTO	KIT RIPARAZIONE MOTORINI AVVIAMENTO	STATORI
IGNITION COILS	REGULATORS & RECTIFIERS	REPAIR KIT	SOLENOID SWITCH	STARTER	STARTER DRIVES	STARTER REPAIR KIT	STATORS
			66-8210		54-8244		
			66-8210		54-8244		

MOTORPARTS
YOUR QUALITY SUPPLIER

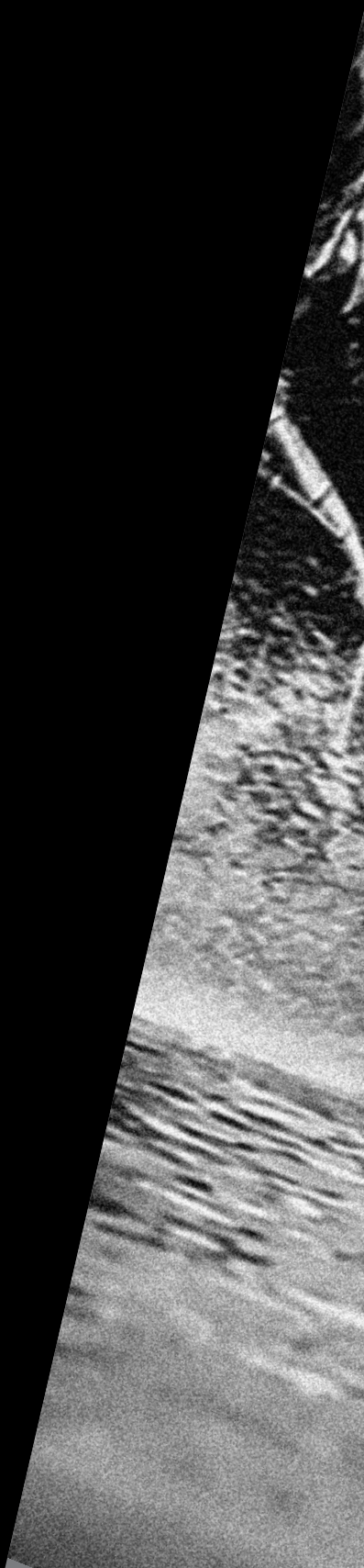



***PERSONAL WATERCRAFT
ELECTRIC PARTS***

ELECTRIC PARTS PERSONAL WATERCRAFT

MARCA MAKE	MODELLO MODEL	CC CC	DA FROM	A TO	REGOLATORI & RADDRIZ- ZATORI REGULATORS & RECTIFIERS	MOTORINI AVVIAMENTO STARTER	KIT RIPARAZIONE MOTO- RINI AVVIAMENTO STARTER REPAIR KIT	STATORE STATOR
ARCTIC CAT	Barracuda		1994	1995		18435N		
	Daytona		1993	1995		18435N		
	Daytona 1000		1997	1997		18435N		
	Daytona 770		1996	1997		18435N		
	Monte Carlo 1000		1997	1997		18435N		
	Monte Carlo 640		1994	1997		18435N		
	Monte Carlo 770		1996	1997		18435N		
	Monte Carlo 900		1996	1996		18435N		
	Montego 640		1994	1997		18435N		
	Montego Deluxe 640		1994	1997		18435N		
	Tigershark 640		1993	1993		18435N		
	Tigershark 900		1995	1995		18435N		
	TS1000L		1998	1998		18435N		
	TS1000R		1998	1998		18435N		
	TS1100Li		1999	1999		18435N		
	TS1100R		1999	1999		18435N		
	TS640		1998	1999		18435N		
	TS770		1998	1999		18435N		
	TS770L		1998	1999		18435N		
	TS770R		1998	1999		18435N		
TS900L		1999	1999		18435N			
HONDA	AquaTrax F-12	1235cc	2002	2007		18431N		
	AquaTrax F-12X	1235cc	2002	2007		18431N		
	AquaTrax F-12X GPScape	1235cc	2005	2007		18431N		
	AquaTrax R-12	1235cc	2004	2006		18431N		
	AquaTrax R-12X	1235cc	2003	2007		18431N		
KAWASAKI	JB650 Jet Mate	650cc	1989	1992		18330N-K	79-85101	
	JF650 TS	650cc	1989	1996	KW1007N	18330N-K	79-85101	
	JF650 X2	650cc	1988	1991	KW1003N			
	JF650 X2	650cc	1988	1995		18330N-K		
	JF650 X2	650cc	1992	1995	KW1007N			
	JH1100 1100ZXi	1071cc	1996	2003	KW1005N	18330N-K	79-85101	
	JH1100 Ultra 130	1071cc	2001	2004		18330N-K	79-85101	
	JH1200 Ultra 150	1176cc	1999	2005	KW1003N	18445N		
	JH750 750SS	750cc	1992	1997	KW1005N	18330N-K	79-85101	
	JH750 750ZXi	750cc	1995	1997	KW1005N	18330N-K	79-85101	
	JH750 Super Sport XI	750cc	1993	1997	KW1001N	18330N-K	79-85101	
	JH750 Xi Sport	750cc	1998	1998	KW1005N			
	JH750 Xi Sport	750cc	1998	1999		18330N-K	79-85101	
	JH750 Xi Sport	750cc	1999	1999	KW1001N			
	JH750 XiR	750cc	1994	1994	KW1005N	18330N-K	79-85101	
	JH900 900ZXi	900cc	1995	1997	KW1005N	18330N-K	79-85101	
	JL650 SC	650cc	1991	1995	KW1007N	18330N-K	79-85101	
	JS400	400cc	1976	1976		18305N		
	JS440	436cc	1977	1992		18305N		
	JS550	530cc	1982	1989		18305N		
JS550 550SX	530cc	1990	1995		18305N			
JS550 550SX		1989	1989		18305N			
JS650 650SX	650cc	1987	1993		18330N-K	79-85101		

MARCA MAKE	MODELLO MODEL	CC CC	DA FROM	A TO	REGOLATORI & RADDRIZ- ZATORI REGULATORS & RECTIFIERS	MOTORINI AVVIAMENTO STARTER	KIT RIPARAZIONE MOTO- RINI AVVIAMENTO STARTER REPAIR KIT	STATORE STATOR
KAWASAKI	JS650 650SX	650cc	1988	1991	KW1003N			
	JS650 650SX	650cc	1992	1993	KW1007N			
	JS750 750SX	750cc	1992	1995	KW1004N	18330N-K	79-85101	
	JS750 750SXi	750cc	1995	1996	KW1004N	18330N-K	79-85101	
	JS750 SXI Pro	750cc	1998	2002	KW1004N	18330N-K	79-85101	
	JS800 800 SX-R	781cc	2011	2011	KW1004N	18330N-K	79-85101	
	JS800 800 SX-R	782cc	2003	2010	KW1004N	18330N-K	79-85101	
	JT1100 1100STX	1071cc	1997	1999	KW1005N	18330N-K	79-85101	
	JT1100 1100STX D.I.	1071cc	2000	2003		18330N-K	79-85101	
	JT1200 1200STX-R	1176cc	2002	2005	KW1004N	18445N		
	JT1200 STX-12F	1176cc	2003	2003	KW1023N			
	JT1200 STX-12F	1176cc	2003	2007		18432N		
	JT1200 STX-12F			2004	2007	KW1005N		
	JT1500 STX	1498cc	2009	2010	KW1005N	18432N		
	JT1500 STX-15F	1498cc	2004	2015		18432N		
	JT1500 STX-15F			2004	2014	KW1005N		
	JT1500 Ultra 250X	1498cc	2007	2008		18432N		
	JT1500 Ultra 250X			2007	2009	KW1005N		
	JT1500 Ultra 250X			2009	2009		18432N	
	JT1500 Ultra 260LX	1498cc	2009	2010	KW1005N	18432N		
	JT1500 Ultra 260X	1498cc	2009	2010	KW1005N	18432N		
	JT1500 Ultra 300 LX	1498cc	2013	2013		18432N		
	JT1500 Ultra 300 LX			2011	2013	KW1005N		
	JT1500 Ultra 300 X	1498cc	2013	2013		18432N		
	JT1500 Ultra 300 X			2011	2013	KW1005N		
	JT1500 Ultra 310LX	1498cc	2014	2015		18432N		
	JT1500 Ultra 310LX			2014	2014	KW1005N		
	JT1500 Ultra 310R	1498cc	2014	2015		18432N		
	JT1500 Ultra 310R			2014	2014	KW1005N		
	JT1500 Ultra 310X	1498cc	2014	2015		18432N		
	JT1500 Ultra 310X			2014	2014	KW1005N		
	JT1500 Ultra LX	1498cc	2007	2015		18432N		
	JT1500 Ultra LX			2007	2014	KW1005N		
JT750 750STX	750cc	1998	1998	1998	KW1001N	18330N-K	79-85101	
JT750 ST	750cc	1994	1995	1995	KW1001N	18330N-K	79-85101	
JT750 STS	750cc	1995	1997	1997	KW1001N	18330N-K	79-85101	
JT900 900STS	891cc	2001	2002	2002	KW1005N	18330N-K	79-85101	
JT900 900STX	891cc	1997	2006	2006	KW1005N	18330N-K	79-85101	
Ultra 300 LX	1498cc	2011	2012			18432N		
Ultra 300 X	1498cc	2011	2012			18432N		
POLARIS	Freedom	701cc	2002	2004	PL1002N			
	Genesis	1165cc	1999	1999	PL1006N			
	Genesis	1165cc	2000	2002	PL1002N			
	Hurricane	700cc	1996	1997	PL1006N			
	Octane	777cc	2002	2004	PL1000N			
	Pro 1200	1165cc	2000	2001	PL1000N			
	Pro 785	785cc	1999	2000		18330N-P		
	Pro 785	785cc	2000	2000	PL1006N			
	SL 1050	1050cc	1997	1997	PL1006N			

ELECTRIC PARTS PERSONAL WATERCRAFT

MARCA MAKE	MODELLO MODEL	CC CC	DA FROM	A TO	REGOLATORI & RADDRIZ- ZATORI REGULATORS & RECTIFIERS	MOTORINI AVVIAMENTO STARTER	KIT RIPARAZIONE MOTO- RINI AVVIAMENTO STARTER REPAIR KIT	STATORE STATOR
POLARIS	SL 650	650cc	1992	1995		18330N-P		
	SL 650	650cc	1995	1995	PL1006N			
	SL 650 Std	650cc	1995	1995		18330N-P		
	SL 750	750cc	1993	1995		18330N-P		
	SL 750	750cc	1994	1995	PL1006N			
	SL 780	780cc	1996	1997	PL1006N	18330N-P		
	SL 900	900cc	1996	1997	PL1006N			
	SLH	700cc	1998	2001	PL1006N			
	SLT 750	750cc	1994	1995		18330N-P		
	SLT 780	780cc	1996	1997	PL1006N	18330N-P		
	SLTH	700cc	1998	1999	PL1006N			
	SLTX	1050cc	1996	1999	PL1006N			
	SLX	1050cc	2000	2001	PL1006N			
	SLX 780	780cc	1995	1996		18330N-P		
	SLX 780	780cc	1996	1996	PL1006N			
	SLX Pro 785	785cc	1997	1998		18330N-P		
	SLXH	1050cc	1998	1998	PL1006N			
	Virage	777cc	2000	2004	PL1002N			
	Virage TX	1165cc	2000	2002	PL1002N			
	Wave Runner					18330N-P		
SEA-DOO	3D DI		2004	2005		18531N		
	3D DI		2005	2007	BR1003N			
	3D DI		2006	2007		18399N		
	3D DI		2007	2007		18532N		
	Challenger		1996	1997	BR1000N			
	Challenger		1998	1999	AS1012N			
	Challenger		2005	2007	BR1003N			
	Explorer		1993	1994		17605N		
	Explorer		1995	1997		18415N		
	Explorer		1996	1997	BR1001N			
	GS	718cc	1997	2001		18415N		
	GSI		1997	1998		18415N		
	GSX	782cc	1996	1997	BR1000N	18416N		
	GSX LTD		1998	1999		18399N		
	GSX RFI	782cc	1999	2000	S1008N	18531N		
	GTI	718cc	1996	1997	BR1001N			
	GTI	718cc	1996	2005		18415N		
	GTI		2014	2015		18532N		
	GTI 130	-- 1503cc	2014	2015		18532N		
	GTI 130	1494cc	2008	2013		18532N		
	GTI LE	718cc	2002	2004		18415N		
	GTI Limited 155	-- 1503cc	2014	2015		18532N		
	GTI Limited 155	1494cc	2011	2013		18532N		
	GTI RFI	782cc	2004	2004	S1008N	18531N		
	GTI SE	1494cc	2006	2007	BR1003N	18532N		
	GTI SE 130	-- 1503cc	2014	2015		18532N		
	GTI SE 130	1494cc	2008	2013		18532N		
	GTI SE 155	-- 1503cc	2014	2015		18532N		
GTI SE 155	1494cc	2008	2013		18532N			

MARCA MAKE	MODELLO MODEL	CC CC	DA FROM	A TO	REGOLATORI & RADDRIZ- ZATORI REGULATORS & RECTIFIERS	MOTORINI AVVIAMENTO STARTER	KIT RIPARAZIONE MOTO- RINI AVVIAMENTO STARTER REPAIR KIT	STATORE STATOR	
SEA-DOO	GTR 215	-- 1503cc	2014	2015		18532N			
	GTR 215	1494cc	2012	2013		18532N			
	GTS	718cc	1992	1995		17605N			
	GTS	718cc	1996	2001	BR1001N	18415N			
	GTS - 2-Passenger			1995	1995		18415N		
	GTS - 3-Passenger			1995	1996		18415N		
	GTS - 3-Passenger			1996	1996	BR1001N			
	GTS 130	-- 1503cc	2014	2015		18532N			
	GTS 130	1494cc	2011	2013		18532N			
	GTX	782cc	1992	1994		17605N			
	GTX	782cc	1996	1997	BR1000N	18416N			
	GTX	782cc	1998	2001		18399N			
	GTX - 2-Passenger			1995	1995		18415N		
	GTX - 3-Passenger			1995	1995		18415N		
	GTX 155	-- 1503cc	2014	2015		18532N			
	GTX 155	1494cc	2008	2013		18532N			
	GTX 215	1494cc	2008	2013		18532N			
	GTX 4-TEC	1494cc	2002	2004		18532N			
	GTX 4-TEC	1494cc	2002	2007	BR1003N				
	GTX DI	951cc	2000	2003	S1008N	18399N			
	GTX iS 215	1494cc	2010	2011		18532N			
	GTX Limited 215	-- 1503cc	2014	2015		18532N			
	GTX Limited iS 255	1494cc	2009	2009		18532N			
	GTX Limited iS 260	-- 1503cc	2014	2015		18532N			
	GTX Limited iS 260	1494cc	2010	2013		18532N			
	GTX RFI	782cc	1998	2002		18416N			
	GTX S 155	-- 1503cc	2014	2015		18532N			
	GTX S 155	1494cc	2012	2013		18532N			
	GTX Wake	1494cc	2005	2007	BR1003N	18532N			
	GTX Wake 155			2005	2008		18532N		
	GTX Wake 215			2008	2008		18532N		
	HX	718cc	1995	1997		18415N			
	HX	718cc	1996	1997	BR1001N				
	Islandia			2006	2007	BR1003N			
	LRV	951cc	2000	2001		18399N			
	LRV DI	951cc	2002	2003	S1008N	18399N			
	RX	951cc	2000	2002		18399N			
	RX DI	951cc	2000	2003	S1008N	18399N			
	RXX	951cc	2001	2001		18399N			
	RXP	1494cc	2004	2007	BR1003N				
	RXP	1494cc	2005	2006		18532N			
	RXP 155	1494cc	2008	2008		18532N			
RXP 215	1494cc	2008	2010		18532N				
RXP X 255	1494cc	2008	2011		18532N				
RXP X 260	-- 1503cc	2014	2015		18532N				
RXP X 260	1494cc	2012	2013		18532N				
RXT	1494cc	2005	2006		18532N				
RXT	1494cc	2005	2007	BR1003N					
RXT 215	1494cc	2008	2010		18532N				

ELECTRIC PARTS PERSONAL WATERCRAFT

MARCA MAKE	MODELLO MODEL	CC CC	DA FROM	A TO	REGOLATORI & RADDRIZ- ZATORI REGULATORS & RECTIFIERS	MOTORINI AVVIAMENTO STARTER	KIT RIPARAZIONE MOTO- RINI AVVIAMENTO STARTER REPAIR KIT	STATORE STATOR	
SEA-DOO	RXT 255		2008	2008		18532N			
	RXT 260	-- 1503cc	2014	2015		18532N			
	RXT 260	1494cc	2011	2013		18532N			
	RXT iS 255	1494cc	2009	2009		18532N			
	RXT iS 260	1494cc	2010	2011		18532N			
	RXT X 255	1494cc	2008	2009		18532N			
	RXT X 260	-- 1503cc	2014	2015		18532N			
	RXT X 260	1494cc	2010	2013		18532N			
	RXT X aS 260	-- 1503cc	2014	2015		18532N			
	RXT X aS 260	1494cc	2011	2013		18532N			
	SP	580cc	1992	1996		17605N			
	SP	580cc	1996	1997	BR1001N				
	SP	580cc	1997	1997		18415N			
	SP 180			2012	2012		18532N		
	SP 210			2011	2012		18532N		
	SP 230			2011	2012		18532N		
	Speedster			1996	1997	BR1001N			
	SPI	580cc	1993	1996	1996		17605N		
	SPI	580cc	1996	1996	1996	BR1001N			
	Sportster			1996	1997	BR1001N			
	Sportster			2004	2006	BR1003N			
	SPX	782cc	1993	1994	1994		17605N		
	SPX	782cc	1995	1997	1997		18415N		
	SPX	782cc	1996	1996	1996	BR1001N			
	SPX	782cc	1997	1999	1999	BR1000N			
	SPX	782cc	1998	1999	1999		18416N		
	Wake 155	-- 1503cc	2014	2014	2015		18532N		
	Wake 155	1494cc	2008	2008	2013		18532N		
	Wake 210			2010	2012		18532N		
	Wake 215	1494cc	2008	2008	2008		18532N		
	Wake 230			2008	2012		18532N		
	Wake Pro 215	-- 1503cc	2014	2014	2015		18532N		
	Wake Pro 215	1494cc	2009	2009	2013		18532N		
	Wake SE 230			2010	2010		18532N		
	XP	782cc	1992	1994	1994		17605N		
	XP	782cc	1995	1995	1995		18415N		
	XP	782cc	1995	1997	1997		18416N		
	XP	782cc	1996	1996	1996	BR1000N			
	XP	782cc	1997	1997	1997	AS1012N			
	XP	782cc	2000	2002	2002		18399N		
	XP DI	951cc	2003	2004	2004	S1008N	18399N		
	YAMAHA	EXS1200 Exciter		1998	1999	YM1029N	18421N		
EXT1100 Exciter			1996	1998	YM1028N	18421N			
EXT1200 Exciter			1998	1999		18421N			
FA1800 WaveRunner FX SHO		1812cc	2013	2013	2015		18895N		
FA1800A WaveRunner FX Cruiser SHO		1812cc	2013	2013	2014		18895N		
FAT1100			2008	2009	2009	YM1038N			
FAT1100			2008	2008	2010		18433N		
FB1800 WaveRunner FX HO		1812cc	2013	2013	2015		18895N		

MARCA MAKE	MODELLO MODEL	CC CC	DA FROM	A TO	REGOLATORI & RADDRIZ- ZATORI REGULATORS & RECTIFIERS	MOTORINI AVVIAMENTO STARTER	KIT RIPARAZIONE MOTO- RINI AVVIAMENTO STARTER REPAIR KIT	STATORE STATOR
YAMAHA	FB1800A WaveRunner FX Cruiser HO	1812cc	2013	2015		18895N		
	FC1800 WaveRunner FX SVHO	1812cc	2014	2015		18895N		
	FC1800A WaveRunner FX Cruiser SVHO	1812cc	2014	2015		18895N		
	FRT1100		2006	2011		18436N		
	FX1000 FX140	998cc	2003	2004		18433N		
	FX1000 WaveRunner FX	998cc	2005	2008		18433N		
	FX1000 WaveRunner FX	998cc	2007	2008	YM1038N			
	FX1000A FX140 Cruiser	998cc	2002	2004		18433N		
	FX1000A WaveRunner FX Cruiser	998cc	2005	2008		18433N		
	FX1100 WaveRunner FX HO	1052cc	2004	2008		18433N		
	FX1100 WaveRunner VX	1052cc	2007	2007		18433N		
	FX1100A WaveRunner FX Cruiser HO	1052cc	2004	2008		18433N		
	FX1100B WaveRunner FX Cruiser HO 50th Ann.	1052cc	2006	2006		18433N		
	FX1800 WaveRunner FX Cruiser SHO	1812cc	2008	2012		18895N		
	FX1800 WaveRunner FX SHO	1812cc	2008	2012		18895N		
	FX700 FX-1	700cc	1994	1995	YM1030N	18420N		
	FY1800 WaveRunner FX HO	1812cc	2009	2011		18895N		
	FY1800A WaveRunner FX Cruiser HO	1812cc	2009	2012		18895N		
	GP1200 WaveRunner GP1200	1176cc	1997	1999	YM1029N			
	GP1200 WaveRunner GP1200	1176cc	1997	2002		18421N		
	GP1200 WaveRunner GP1200	1176cc	2000	2002	YM1004N			
	GP1300 WaveRunner GP1300R	1297cc	2003	2008		18421N		
	GP1300 WaveRunner GP1300R	1297cc	2005	2008	YM1038N			
	GP760 WaveRunner GP760	760cc	1997	2000	YM1030N	18894N		
	GP800 WaveRunner GP800	800cc	1998	2000	YM1028N	18421N		
	GP800A WaveRunner GP800R	800cc	2001	2005	YM1028N	18421N		
	GX1800 WaveRunner FZR	1812cc	2009	2015		18895N		
	GX1800A WaveRunner FZS	1812cc	2009	2015		18895N		
	LAT1100			2012	2015		18436N	
	LST1200			1999	2005	YM1029N	18421N	
	RA1100 WaveRaider 1100	1052cc	1995	1996	YM1028N	18421N		
	RA700 WaveRaider	699cc	1994	1997	YM1030N	18420N		
	RA700A WaveRaider Deluxe	699cc	1995	1995		18420N		
	RA760 WaveRaider 760	760cc	1996	1996	YM1030N	18894N		
	RM1800			2013	2015		18436N	
	RX1800			2012	2015		18895N	
	SAT1800			2015	2015		18895N	
	SJ650 Super Jet	650cc	1990	1993	YM1030N	18420N		
	SJ700 Super Jet	701cc	1994	2015		18420N		
	SJ700 Super Jet	701cc	1994	2016	YM1030N			
	SRT1000			2003	2006		18433N	
	SRT1100			2005	2005		18433N	
SV1200 WaveRunner SUV1200	1176cc		1999	2004		18421N		
SXT1100			2007	2009	YM1038N	18433N		
SXT1800			2010	2014		18895N		
VX1050B VX Cruiser Deluxe			2016	2016	YM1038N			
VX1050C VX			2016	2016	YM1038N			
VX1050D V1 Sport			2016	2016	YM1038N			
VX1050E V1			2016	2016	YM1038N			

ELECTRIC PARTS PERSONAL WATERCRAFT

MARCA MAKE	MODELLO MODEL	CC CC	DA FROM	A TO	REGOLATORI & RADDRIZ- ZATORI REGULATORS & RECTIFIERS	MOTORINI AVVIAMENTO STARTER	KIT RIPARAZIONE MOTO- RINI AVVIAMENTO STARTER REPAIR KIT	STATORE STATOR	
YAMAHA	VX1050F VX Limited		2016	2016	YM1038N				
	VX1100 WaveRunner 1100 Sport	1052cc	2005	2006		18436N			
	VX1100 WaveRunner VX	1052cc	2007	2010		18436N			
	VX1100 WaveRunner VX		2015	2015		18436N			
	VX1100A WaveRunner 1100 Deluxe	1052cc	2005	2006		18436N			
	VX1100A WaveRunner VX Cruiser	1052cc	2007	2015		18436N			
	VX1100B WaveRunner VX Deluxe	1052cc	2007	2015		18436N			
	VX1100C WaveRunner VX Sport	1052cc	2007	2015		18436N			
	VX1800AK WaveRunner VXR	1812cc	2011	2015		18895N			
	VX1800K WaveRunner VXS	1812cc	2011	2015		18895N			
	WB700 WaveBlaster	--L 700cc -cid	1994	1995				27-7028	
	WB700 WaveBlaster	700cc	1994	1996	YM1030N	18420N			
	WB700 WaveBlaster	800cc	1993	1993	YM1030N	18420N		27-7028	
	WB760 WaveBlaster 760	760cc	1996	1997	YM1030N	18894N			
	WJ500 WaveJammer	500cc	1987	1990	YM1039N				
	WR500 WaveRunner	499cc	1987	1993	YM1039N				
	WR650 WaveRunner LX	650cc	1990	1993	YM1030N	18420N		27-7028	
	WRA650 WaveRunner III	--L 650cc -cid	1990	1995				27-7028	
	WRA650 WaveRunner III	650cc	1990	1996		18420N			
	WRA650 WaveRunner III	650cc	1990	1997	YM1030N				
	WRA700 WaveRunner 3	696cc	1994	1994		18420N			
	WRA700 WaveRunner III 700	696cc	1997	1997		18420N			
	WRA700 WaveRunner III 700		1994	1995				27-7028	
	WRA700 WaveRunner III GP	696cc	1995	1995	YM1030N	18420N			
	WRA700 WaveRunner III GP		1994	1994	YM1030N				
	WRB650 WaveRunner VXR	--L 650cc -cid	1992	1995				27-7028	
	WRB650 WaveRunner VXR	650cc	1991	1995	YM1030N	18420N			
	WRB700 WaveRunner Pro VXR	696cc	1993	1994	YM1030N	18420N		27-7028	
	WVT1100 WaveVenture 1100	1052cc	1996	1997	YM1028N	18421N			
	WVT700 WaveVenture 700	696cc	1995	1998	YM1030N	18420N			
	WVT760 WaveVenture 760	760cc	1997	1997	YM1030N	18894N			
	XA1200 WaveRunner XL12 LTD	1176cc	1999	2000		18421N			
	XA1200 WaveRunner XLT1200	1176cc	2009	2009		18421N			
	XA1200A WaveRunner XLT1200	1176cc	2001	2005		18421N			
	XA800 WaveRunner XL800	784cc	2000	2001		18421N			
	XA800A WaveRunner XLT800	784cc	2002	2004		18421N			
	XAT1800			2012	2015		18895N		
	XL1200 WaveRunner XL1200	1176cc	1998	1998	YM1029N	18421N			
	XL1200 WaveRunner XL1200	1176cc	1999	2000	YM1004N				
	XL700 WaveRunner XL700	696cc	1999	2001		18420N			
	XL700 WaveRunner XL700	696cc	1999	2004	YM1030N				
	XL700A WaveVenture XL700	696cc	2002	2004		18420N			
	XL760 WaveRunner XL760	760cc	1998	1999	YM1030N	18894N			
	XLT1200 WaveRunner XLT1200			2002	2005	YM1004N			
	XRT1200			2000	2001		18421N		
	YAMAHA (BOATS)	RM1800 AR192	1812cc	2013	2013		18895N		
		RM1800 SX192	1812cc	2013	2013		18895N		

MOTORPARTS
YOUR QUALITY SUPPLIER

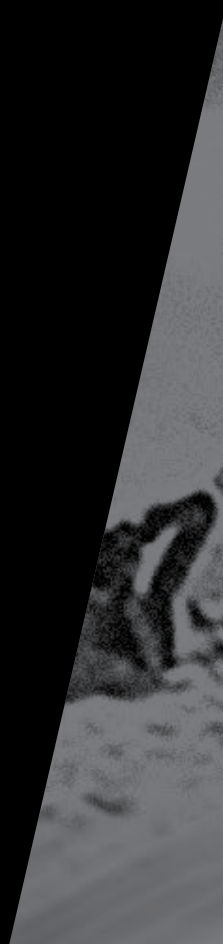

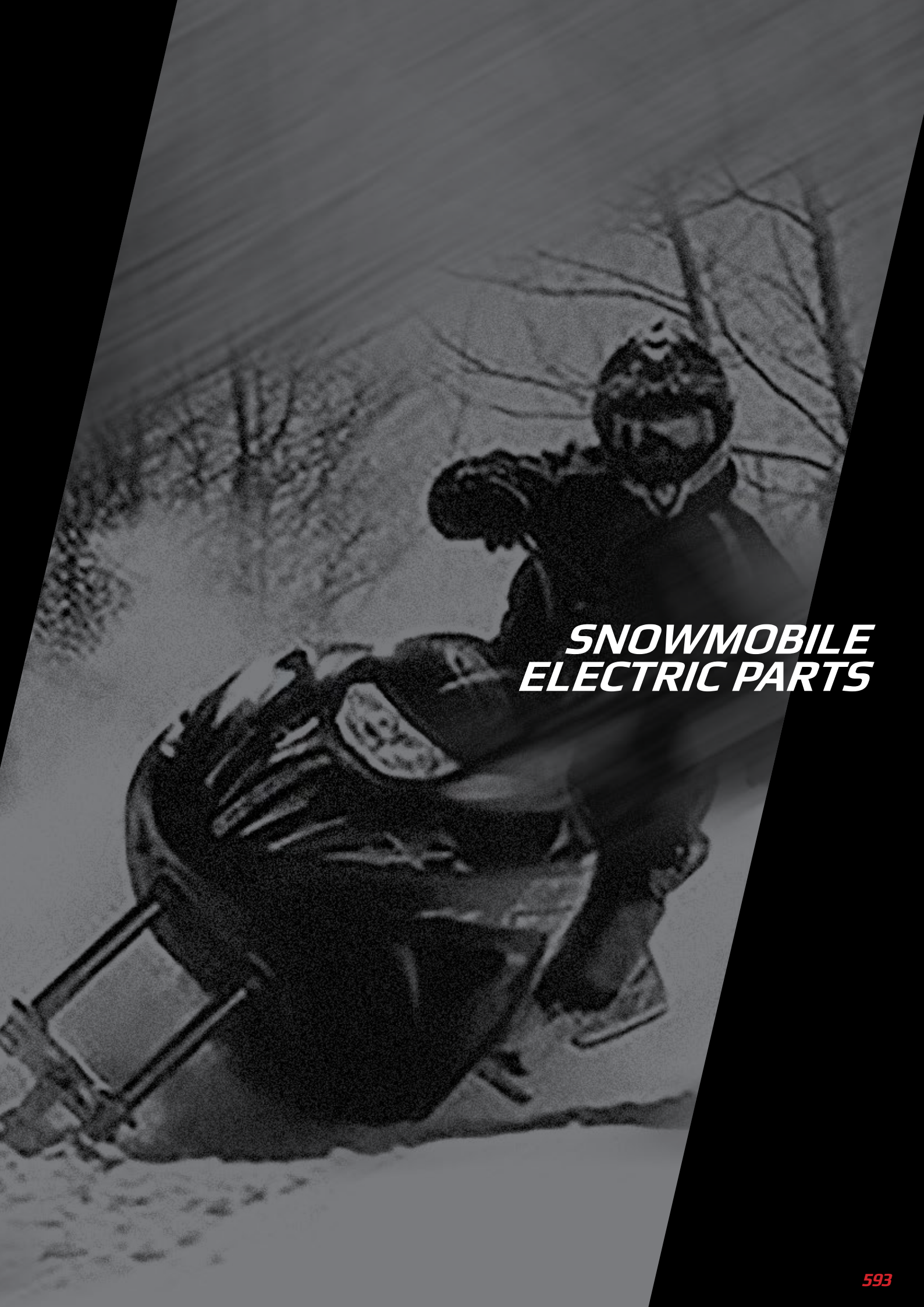

***SNOWMOBILE
ELECTRIC PARTS***

ELECTRIC PARTS SNOWMOBILE

MARCA MAKE	MODELLO MODEL	CC CC	DA FROM	A TO	ALTERNATORE ALTERNATORE	REGOLATORI & RADDRIZZATORI REGULATORS & RECTIFIERS	MOTORINI AVVIAMENTO STARTER	STATORE STATOR	
ARCTIC CAT	700 Diesel	695cc	2007	2009	13127N-55A				
	Bearcat 340	340cc	1995	1997		AC1000N			
	Bearcat 340	340cc	1995	2000			5944N		
	Bearcat 440	440cc	1995	1997		AC1000N			
	Bearcat 440	440cc	1995	1998			5944N		
	Bearcat 454 2x4	454cc	1997	1997		AC1000N			
	Bearcat 454 4x4	454cc	1996	1997		AC1000N			
	Bearcat 550	550cc	1995	1996			5943N		
	Bearcat 570 Long Track	570cc	2004	2008			5945N		
	Bearcat Widetrack	550cc	1996	1999			5943N		
	Bearcat Widetrack	550cc	1999	2002		AC1003N			
	Bearcat Widetrack	550cc	2006	2008	12877N				
	Bearcat Widetrack Turbo	660cc	2006	2008	12877N				
	Cheetah 340	340cc	1994	1994			5944N		
	Cheetah 440	440cc	1993	1994			5944N		
	Cheetah 550	550cc	1994	1994			5943N		
	Cougar	550cc	1991	1998			5943N		
	Cougar	550cc	1995	1997		AC1000N			
	Cougar 2-Up	500cc	1996	1996		AC1000N			
	Cougar 440			1991	1992			5944N	
	Cougar Deluxe	500cc	1998	1998			5943N		
	Cougar Mountain Cat	500cc	1993	1998			5943N		
	Cougar Mountain Cat	500cc	1995	1997		AC1000N			
	El Tigre EXT	600cc	1989	1991			5944N		
	El Tigre EXT Mountain Cat	600cc	1989	1991			5944N		
	EXT 550	550cc	1992	1993			5943N		
	EXT 550	550cc	1993	1993				27-7036	
	EXT 580	580cc	1994	1996			5943N		
	EXT 580	580cc	1995	1996		AC1000N			
	EXT 580 EFI	580cc	1997	1998			5943N		
	EXT 580 EFI	580cc	1998	1998				27-7032	
	EXT 580 EFI			1994	1996			27-7036	
	EXT 580 EFI Deluxe	580cc	1996	1996				27-7036	
	EXT 580 EFI Deluxe	580cc	1996	1997		AC1000N			
	EXT 580 EFI Deluxe	580cc	1996	1998			5943N		
	EXT 580 Mountain Cat	580cc	1992	1994			5943N		
	EXT 580 Mountain Cat	580cc	1993	1994				27-7036	
	EXT 580 Mountain Cat			1995	1996			27-7036	
	EXT 580 Powder Special			1995	1995			27-7036	
	EXT 580 Powder Special			1995	1996		AC1000N	5943N	
	EXT 580 Z	600cc	1993	1993			5943N		
	EXT 600	600cc	1997	1997		AC1000N	5943N		
	EXT 600 Tour	600cc	1998	1998			5943N		
	EXT 600 Triple	600cc	1998	1998			5943N		
	EXT EFI	550cc	1995	1996		AC1000N			
	EXT EFI Mountain Cat	550cc	1995	1996		AC1000N			
EXT Powder Special	550cc	1995	1996		AC1000N	5943N			
F1000 EFI	1000cc	2007	2008			5945N			
F1000 EFI LXR	1000cc	2007	2008			5945N			

MARCA MAKE	MODELLO MODEL	CC CC	DA FROM	A TO	ALTERNATORE ALTERNATORE	REGOLATORI & RADDRIZZATORI REGULATORS & RECTIFIERS	MOTORINI AVVIAMENTO STARTER	STATORE STATOR
ARCTIC CAT	F1000 EFI Sno Pro	1000cc	2007	2008			5945N	
	F5	499cc	2013	2014			5945N	
	F5 EFI	500cc	2007	2009			5945N	
	F5 EFI LXR	499cc	2009	2011			5945N	
	F5 EFI LXR	500cc	2007	2008			5945N	
	F5 LXR	499cc	2012	2012			5945N	
	F6 EFI	600cc	2007	2008			5945N	
	F6 EFI LXR	600cc	2007	2008			5945N	
	F6 EFI Sno Pro	599cc	2009	2011			5945N	
	F6 EFI Sno Pro	600cc	2007	2008			5945N	
	F8 EFI	800cc	2007	2010			5945N	
	F8 EFI LXR	794cc	2009	2011			5945N	
	F8 EFI LXR	800cc	2007	2008			5945N	
	F8 EFI LXR LE	800cc	2009	2009			5945N	
	F8 EFI Sno Pro	794cc	2009	2011			5945N	
	F8 EFI Sno Pro	800cc	2007	2008			5945N	
	F8 EFI Sno Pro Tony Stewart	800cc	2007	2007			5945N	
	F8 EXT	794cc	2011	2011			5945N	
	F8 Sno Pro Limited	794cc	2010	2011			5945N	
	Jag	340cc	1995	1997		AC1000N		
	Jag	340cc	1997	1997			5944N	
	Jag 340	340cc	1989	1998			5944N	
	Jag 340 Deluxe	340cc	1988	1999			5944N	
	Jag 340 Mountain Cat		1990	1991			5944N	
	Jag 440	440cc	1998	1999			5944N	
	Jag 440 AFS Special		1991	1991			5944N	
	Jag 440 Deluxe	440cc	1993	1999			5944N	
	Jag 440 Deluxe	440cc	1995	1997		AC1000N		
	Jag AFS	440cc	1989	1991			5944N	
	Jag AFS Deluxe	440cc	1990	1991			5944N	
	Jag AFS Long Track	440cc	1990	1991			5944N	
	Jag AFS LT 1 Speed	440cc	1992	1993			5944N	
	Jag Deluxe	440cc	1995	1997		AC1000N		
	Jag Liquid	440cc	1996	1996		AC1000N	5944N	
	Jag Special	440cc	1992	1992			5944N	
	Jag Z	440cc	1993	1994			5944N	
	King Cat 900	900cc	2004	2005			5945N	
	King Cat 900 EFI	900cc	2005	2006			5945N	
	King Cat 900 EFI Early Build	900cc	2005	2005			5945N	
	Kitty Cat	60cc	1995	1997		AC1000N		
	Lynx	340cc	1991	1993			5944N	
	Lynx Deluxe	340cc	1991	1993			5944N	
	Lynx Mountain Cat	340cc	1992	1993			5944N	
	Mountain Cat 1000	1000cc	2001	2002			5943N	
	Mountain Cat 500	500cc	2002	2002			5945N	
	Mountain Cat 500 EFI	500cc	2001	2001			5945N	
	Mountain Cat 570	570cc	2002	2004			5945N	
Mountain Cat 600 EFI	600cc	2001	2004			5945N		
Mountain Cat 600 EFI 136	600cc	2003	2003			5945N		

ELECTRIC PARTS SNOWMOBILE

MARCA MAKE	MODELLO MODEL	CC CC	DA FROM	A TO	ALTERNATORE ALTERNATORE	REGOLATORI & RADDRIZZATORI REGULATORS & RECTIFIERS	MOTORINI AVVIAMENTO STARTER	STATORE STATOR
ARCTIC CAT	Mountain Cat 600 EFI 144	600cc	2003	2003			5945N	
	Mountain Cat 600 EFI LE	600cc	2001	2002			5945N	
	Mountain Cat 600 VEV	600cc	2001	2001			5945N	
	Mountain Cat 800	800cc	2001	2002			5945N	
	Mountain Cat 800 EFI	800cc	2002	2002			5945N	
	Mountain Cat 800 EFI 144	800cc	2003	2003			5945N	
	Mountain Cat 800 EFI 151	800cc	2003	2004			5945N	
	Mountain Cat 800 EFI 159	800cc	2004	2004			5945N	
	Mountain Cat 800 EFI LE 144	800cc	2002	2002			5945N	
	Mountain Cat 800 EFI LE 151	800cc	2002	2002			5945N	
	Mountain Cat 800 LE	800cc	2001	2001			5945N	
	Mountain Cat 800 LE 144	800cc	2002	2002			5945N	
	Mountain Cat 800 LE 151	800cc	2002	2002			5945N	
	Mountain Cat 900 144	900cc	2003	2003			5945N	
	Mountain Cat 900 151	900cc	2003	2004			5945N	
	Mountain Cat 900 159	900cc	2004	2004			5945N	
	Mountain Cat 900 1M	900cc	2003	2003			5945N	
	Mountain Cat 900 Early Build	900cc	2003	2003			5945N	
	Mountain Cat 900 EFI 151	900cc	2004	2004			5945N	
	Mountain Cat 900 EFI 159	900cc	2004	2004			5945N	
	Pantera	440cc	1988	1992			5944N	
	Pantera	550cc	1995	1997		AC1000N		
	Pantera 1000	1000cc	2000	2001			5943N	
	Pantera 440	440cc	1991	1992			5944N	
	Pantera 550	550cc	2002	2005		AC1003N	5945N	
	Pantera 550		1993	1994				27-7036
	Pantera 580	580cc	1998	1998			5943N	
	Pantera 580		1999	2001				27-7032
	Pantera 580 EFI	580cc	1999	2001			5943N	
	Pantera 580 EFI		1995	1996				27-7036
	Pantera 600 EFI	600cc	2004	2005		AC1003N	5945N	
	Pantera 800	--L 800cc -cid	1998	1999		AC1003N	5943N	27-7029
	Pantera 800 EFI	800cc	2004	2004			5945N	
	Pantera 800 EFI ESR	800cc	2002	2003			5945N	
	Panther	440cc	1989	1993			5944N	
	Panther 340	340cc	1998	2000			5944N	
	Panther 370	370cc	2001	2008			5944N	
	Panther 370 R	370cc	2003	2006			5944N	
	Panther 440	440cc	1997	1997		AC1000N		
	Panther 440	440cc	1997	2002			5944N	
	Panther 440 ESR	440cc	2001	2001			5944N	
	Panther 550	550cc	1997	1997		AC1000N		
Panther 550	550cc	1997	2001			5943N		
Panther 570	570cc	2004	2007			5945N		
Panther 570 ESR	570cc	2002	2003			5945N		
Panther 570 R	570cc	2002	2002			5945N		
Panther 660		2006	2008		12877N			
Panther Deluxe	440cc	1991	1996			5944N		
Panther Deluxe	440cc	1995	1996			AC1000N		

MARCA MAKE	MODELLO MODEL	CC CC	DA FROM	A TO	ALTERNATORE ALTERNATORE	REGOLATORI & RADDRIZZATORI REGULATORS & RECTIFIERS	MOTORINI AVVIAMENTO STARTER	STATORE STATOR
ARCTIC CAT	Panther LC	440cc	1996	1996		AC1000N	5944N	
	Panther Mountain Cat	440cc	1990	1991			5944N	
	Powder Extreme	600cc	1997	1997		AC1000N		
	Powder Extreme	600cc	1997	1998			5943N	
	Powder Special 500 EFI	--L 500cc -cid	1999	2000				27-7032
	Powder Special 580 EFI		1997	1997				27-7032
	Powder Special 600	--L 600cc -cid	1998	1999				27-7032
	Powder Special 600	600cc	1997	1997			5943N	
	Prowler	440cc	1990	1992			5944N	
	Prowler 2-Up	440cc	1995	1995		AC1000N		
	Prowler Mountain Cat	440cc	1991	1992			5944N	
	Prowler Special	440cc	1991	1992			5944N	
	Puma	340cc	1994	1997			5944N	
	Puma	340cc	1995	1997		AC1000N		
	Puma 2-Up	340cc	1994	1997			5944N	
	Puma 2-Up	340cc	1995	1997		AC1000N		
	Puma Deluxe	340cc	1994	1997			5944N	
	Puma Deluxe	340cc	1995	1997		AC1000N		
	Sabercat 500	500cc	2004	2005			5945N	
	Sabercat 500 EFI	500cc	2006	2006			5945N	
	Sabercat 500 EFI LX	500cc	2006	2006			5945N	
	Sabercat 500 LX	500cc	2004	2005			5945N	
	Sabercat 600	600cc	2004	2004			5945N	
	Sabercat 600 EFI	600cc	2004	2005			5945N	
	Sabercat 600 EFI EXT	600cc	2004	2005			5945N	
	Sabercat 600 EFI LX	600cc	2004	2006			5945N	
	Sabercat 600 LX	600cc	2004	2004			5945N	
	Sabercat 700 EFI	700cc	2004	2005			5945N	
	Sabercat 700 EFI EXT	700cc	2004	2006			5945N	
	Sabercat 700 EFI LX	700cc	2004	2006			5945N	
	Super Jag	440cc	1989	1992			5944N	
	T500	500cc	2008	2009			5945N	
	T660 Touring	660cc	2004	2008	12877N			
	T660 Turbo	660cc	2005	2005	12877N			
	T660 Turbo ST	660cc	2005	2006	12877N			
	T660 Turbo ST EFI Early Build	660cc	2005	2005	12877N			
	T660 Turbo Touring	660cc	2004	2007	12877N			
	Thundercat	--L 999cc -cid	1998	1999				27-7029
	Thundercat	895cc	1995	1997		AC1000N		
	Thundercat	895cc	1997	2002			5943N	
Thundercat	900cc	1993	1997				27-7029	
Thundercat MC	--L 999cc -cid	1999	1999				27-7029	
Thundercat MC	1000cc	1997	1997		AC1000N			
Thundercat MC	1000cc	1997	2000			5943N		
Thundercat MC	900cc	1998	1998				27-7029	
Thundercat MC		1994	1997				27-7029	
Thundercat Mountain Cat	1000cc	1995	1996		AC1000N			
Thundercat THC	1000cc	2000	2000			5943N		
Triple Touring	600cc	1999	2001			5943N		

ELECTRIC PARTS SNOWMOBILE

MARCA MAKE	MODELLO MODEL	CC CC	DA FROM	A TO	ALTERNATORE ALTERNATORE	REGOLATORI & RADDRIZZATORI REGULATORS & RECTIFIERS	MOTORINI AVVIAMENTO STARTER	STATORE STATOR
ARCTIC CAT	Wildcat 700 EFI		1991	1996				27-7036
	Wildcat 700 Mountain Cat EFI		1991	1996				27-7036
	Wildcat 700 Touring R		1996	1996				27-7036
	Wildcat EFI	700cc	1995	1996		AC1000N		
	Wildcat Mountain Cat	700cc	1995	1996		AC1000N		
	Wildcat Touring	700cc	1995	1996		AC1000N		
	Z 370	370cc	1999	1999			5943N	
	Z 370	370cc	2000	2007		AC1003N	5944N	
	Z 370 ES	370cc	2000	2002			5944N	
	Z 370 ESR	370cc	2003	2003			5944N	
	Z 370 IPM		2001	2001			5944N	
	Z 370 LX	370cc	2004	2007			5944N	
	Z 440	440cc	1995	1997		AC1000N		
	Z 440	440cc	1995	1999			5943N	
	Z 440	440cc	2000	2002		AC1003N	5944N	
	Z 440 ES	440cc	2000	2002			5944N	
	Z 440 ESR	440cc	2003	2003			5944N	
	Z 440 LX	440cc	2004	2006			5944N	
	Z 440 Sno Pro	440cc	1999	2003			5944N	
	Z 570	570cc	2002	2007			5945N	
	Z 570 ESR	570cc	2002	2003			5945N	
	Z 570 LX	570cc	2004	2007			5945N	
	Z 570 SS	570cc	2002	2002			5945N	
	ZL 500	-- -L 500cc -cid	1999	2000				27-7032
	ZL 500	500cc	2002	2002			5945N	
	ZL 500 EFI ESR	500cc	2001	2001			5945N	
	ZL 550	550cc	2001	2003		AC1003N	5945N	
	ZL 550 ESR	550cc	2000	2000			5943N	
	ZL 550 ESR	550cc	2001	2003			5945N	
	ZL 580 EFI ESR	580cc	2000	2000			5943N	27-7032
	ZL 600	-- -L 600cc -cid	1999	1999				27-7032
	ZL 600 EFI	600cc	2001	2003			5945N	
	ZL 600 EFI ESR	600cc	2001	2003			5945N	
	ZL 600 EFI SS	600cc	2002	2003			5945N	
	ZL 600 EFI SS ESR	600cc	2002	2003			5945N	
	ZL 800 EFI ESR	800cc	2002	2003			5945N	
	ZL 800 EFI SS	800cc	2002	2003			5945N	
	ZL 800 ESR	800cc	2001	2001			5945N	
	ZR 400	400cc	1995	1995		AC1000N		
	ZR 440	440cc	1995	1997		AC1000N		
ZR 500	-- -L 500cc -cid	1999	2000				27-7032	
ZR 500	500cc	2001	2002			5945N		
ZR 500 EFI	500cc	2001	2001			5945N		
ZR 500 EFI ESR	500cc	2001	2001			5945N		
ZR 500 LE	500cc	2002	2002			5945N		
ZR 580	580cc	1995	1996		AC1000N			
ZR 580		1997	1997				27-7032	
ZR 580 EFI	580cc	1995	1996				27-7036	
ZR 580 EFI	580cc	1995	1997		AC1000N			

MARCA MAKE	MODELLO MODEL	CC CC	DA FROM	A TO	ALTERNATORE ALTERNATORE	REGOLATORI & RADDRIZZATORI REGULATORS & RECTIFIERS	MOTORINI AVVIAMENTO STARTER	STATORE STATOR
LYNX	Touring 500		2000	2000			18871N	
	XR 500F		1999	2000			18871N	
	YETI 550		2008	2008			18871N	
	YETI 550 Pro		2008	2008			18871N	
	YETI 600HO TUV SDI		2006	2006			18875N	
POLARIS POLARIS	340	339cc	1999	2008			5768N	
	500	488cc	1997	2005			5768N	
	500	599cc	2006	2006			5768N	
	550	544cc	2009	2009			10927N	
	600	599cc	2010	2010			10927N	
	800	794cc	2009	2009			10927N	
	340 Classic	339cc	2003	2006			5768N	
	340 Classic	339cc	2005	2006		PL1007N		
	340 Deluxe	339cc	1999	2002			5768N	
	340 Edge	339cc	2003	2003		PL1007N	5768N	
	340 Indy		1999	2004			5768N	
	340 Indy		2004	2004		PL1001N		
	340 Indy Deluxe		1999	1999			5768N	
	340 LX	339cc	2007	2007		PL1007N	5768N	
	340 Touring	339cc	1999	2007			5768N	
	340 Touring	339cc	2005	2007		PL1007N		
	340 Transport	339cc	2008	2008		PL1001N	5768N	
	440 IQ	438cc	2005	2007		PL1001N		
	440 Pro X	438cc	2002	2003		PL1001N		
	440 Pro XR	438cc	2004	2004		PL1001N		
	440 XC SP	438cc	2000	2000		PL1001N		
	440 XC SP		2001	2001		PL1001N		
	500 Classic	488cc	1999	2006			5768N	
	500 Classic	488cc	2002	2006		PL1007N		
	500 Classic Touring	488cc	2001	2003			5768N	
	500 Classic Touring	488cc	2002	2003		PL1007N		
	500 EFI	488cc	1997	1997			5768N	
	500 SKS	488cc	1997	1997			5768N	
	500 XC	488cc	2003	2003		PL1001N	5768N	
	500 XC SP	488cc	2001	2007		PL1001N		
	500 XC SP	488cc	2002	2005		PL1007N		
	500 XC SP	488cc	2002	2007			5768N	
	550 Classic	544cc	2002	2006		PL1007N	5768N	
550 IQ LXT	544cc	2011	2013		PL1007N			
550 IQ Shift	544cc	2009	2013		PL1007N			
550 LX	544cc	2007	2008		PL1007N	5768N		
550 Pro X Fan	544cc	2004	2004		PL1001N			
550 Shift 136	544cc	2012	2013		PL1007N			
550 Transport	544cc	2009	2009			5768N		
600 Classic	599cc	2001	2006		PL1007N	5768N		
600 Classic Touring	599cc	2001	2004			5768N		
600 Classic Touring	599cc	2002	2004		PL1007N			
600 Dragon		2009	2009			5927N		
600 Dragon IQ	599cc	2008	2008			5927N		

ELECTRIC PARTS SNOWMOBILE

MARCA MAKE	MODELLO MODEL	CC CC	DA FROM	A TO	ALTERNATORE ALTERNATORE	REGOLATORI & RADDRIZZATORI REGULATORS & RECTIFIERS	MOTORINI AVVIAMENTO STARTER	STATORE STATOR	
POLARIS	600 Dragon SP	599cc	2009	2009			5927N		
	600 Dragon SwitchBack	599cc	2008	2009			5927N		
	600 Edge Touring		2005	2006		PL1007N	5768N		
	600 HO CFI SwitchBack	599cc	2007	2007			5927N		
	600 HO CFI Touring	599cc	2007	2007			5927N		
	600 HO IQ	599cc	2007	2007			5927N		
	600 HO IQ CFI	599cc	2007	2007			5927N		
	600 HO IQ LX CFI	599cc	2007	2007			5927N		
	600 HO IQ Touring	599cc	2008	2008			5927N		
	600 IQ	599cc	2009	2009			5927N		
	600 IQ CFI			2007	2007			5927N	
	600 IQ LX	599cc	2008	2008			5927N		
	600 IQ Racer			2010	2015		PL1001N		
	600 IQ Shift	599cc	2009	2009			PL1007N		
	600 IQ Touring	599cc	2007	2009				5927N	
	600 IQ Widetrack	599cc	2011	2012			PL1020N		
	600 IQ Widetrack			2010	2010		PL1020N		
	600 Pro Ride Rush			2010	2010		PL1020N		
	600 PRO X	599cc	2001	2004			PL1001N		
	600 PRO-RMK 155	599cc	2012	2012			PL1007N		
	600 RMK	599cc	2002	2005			PL1001N		
	600 RMK	599cc	2004	2005			PL1007N		
	600 RMK	599cc	2004	2006				5768N	
	600 RMK			2009	2012		PL1020N		
	600 RMK			2012	2012		PL1007N		
	600 Rush	599cc	2011	2012			PL1007N		
	600 Rush PRO-R	599cc	2011	2012			PL1020N		
	600 Rush PRO-R			2010	2010		PL1007N		
	600 SwitchBack	599cc	2004	2005			PL1001N		
	600 SwitchBack	599cc	2004	2009				5768N	
	600 SwitchBack	599cc	2004	2012			PL1007N		
	600 SwitchBack	599cc	2012	2012			PL1020N		
	600 SwitchBack Adventure	599cc	2013	2013			PL1020N		
	600 SwitchBack PRO-R	599cc	2012	2012			PL1007N		
	600 Touring	599cc	2000	2006				5768N	
	600 XC	599cc	2003	2003			PL1001N	5768N	
	600 XC Deluxe	599cc	2000	2000				5768N	
	600 XC SP	599cc	2000	2005			PL1001N		
	600 XC SP	599cc	2002	2005			PL1007N	5768N	
	700 Classic	700cc	2001	2006				5768N	
	700 Classic	700cc	2002	2004			PL1007N		
	700 Classic Touring	700cc	2003	2004			PL1007N	5768N	
	700 Dragon IQ	700cc	2008	2008				5927N	
	700 Dragon SwitchBack	700cc	2008	2008				5927N	
	700 Fusion	700cc	2006	2006				5926N	
	700 HO Touring	700cc	2006	2006				5926N	
	700 IQ	700cc	2008	2008				5927N	
700 PRO X	700cc	2003	2004			PL1001N			
700 RMK	700cc	2002	2005			PL1001N	5768N		

MARCA MAKE	MODELLO MODEL	CC CC	DA FROM	A TO	ALTERNATORE ALTERNATORE	REGOLATORI & RADDRIZZATORI REGULATORS & RECTIFIERS	MOTORINI AVVIAMENTO STARTER	STATORE STATOR	
POLARIS	700 RMK	700cc	2003	2005		PL1007N			
	700 RMK 144	700cc	2006	2006			5926N		
	700 RMK 155	700cc	2009	2009			5927N		
	700 RMK151	700cc	2006	2006			5926N		
	700 RMK159	700cc	2006	2006			5926N		
	700 SKS	700cc	2003	2003		PL1001N	5768N		
	700 SwitchBack	700cc	2004	2004		PL1001N	5768N		
	700 SwitchBack	700cc	2008	2008			5927N		
	700 Touring HO	700cc	2006	2006			5926N		
	700 XC	700cc	2003	2004		PL1001N	5768N		
	700 XC SP	700cc	2001	2005		PL1001N			
	700 XC SP	700cc	2002	2005		PL1007N	5768N		
	800 Classic	794cc	2004	2004		PL1007N	5768N		
	800 Classic Touring	794cc	2003	2004		PL1007N	5768N		
	800 Dragon	794cc	2009	2009			5927N		
	800 Dragon RMK			2009	2009			5927N	
	800 Dragon SP	794cc	2009	2009			5927N		
	800 Edge Touring			2005	2005			5768N	
	800 IQ	794cc	2009	2009			5927N		
	800 LE	794cc	2001	2001		PL1001N			
	800 PRO RMK			2011	2012		PL1020N		
	800 PRO X	794cc	2003	2004		PL1001N			
	800 PRO-RMK 155	795cc	2011	2012		PL1007N			
	800 PRO-RMK 163	795cc	2011	2012		PL1007N			
	800 RMK	794cc	2002	2005		PL1001N			
	800 RMK	794cc	2003	2005		PL1007N	5768N		
	800 RMK			2011	2012		PL1007N		
	800 Rush	795cc	2011	2012		PL1007N			
	800 Rush ES			2011	2012		PL1020N		
	800 Rush PRO-R	795cc	2011	2011		PL1007N			
	800 Rush PRO-R	795cc	2011	2012		PL1020N			
	800 SKS	794cc	2003	2003		PL1001N	5768N		
	800 SwitchBack	794cc	2004	2005		PL1001N	5768N		
	800 SwitchBack	794cc	2009	2009			5927N		
	800 SwitchBack	795cc	2011	2012		PL1007N			
	800 SwitchBack PRO-R	795cc	2012	2012		PL1007N			
	800 Touring	794cc	2004	2005			5768N		
	800 XC	794cc	2003	2004		PL1007N	5768N		
	800 XC Edge			2003	2004		PL1001N	5768N	
	800 XC SP	794cc	2001	2005			5768N		
	800 XC SP	794cc	2002	2005		PL1001N			
	800 XC Special			2002	2005			5768N	
	900 Fusion	866cc	2005	2006			5926N		
	900 RMK	866cc	2005	2006			5926N		
	900 Switchback	866cc	2005	2006			5926N		
Classic	488cc	1997	1998			5768N			
Classic Touring	488cc	1997	2000			5768N			
Frontier	784cc	2002	2002			18648N			
Frontier Classic	784cc	2003	2004			18648N			

ELECTRIC PARTS SNOWMOBILE

MARCA MAKE	MODELLO MODEL	CC CC	DA FROM	A TO	ALTERNATORE ALTERNATORE	REGOLATORI & RADDRIZZATORI REGULATORS & RECTIFIERS	MOTORINI AVVIAMENTO STARTER	STATORE STATOR	
POLARIS	Frontier Touring	784cc	2003	2005			18648N		
	FS Classic	750cc	2006	2006			5925N		
	FS IQ Touring	750cc	2007	2009			5925N		
	FS IQ Widetrack	599cc	2011	2012			5925N		
	FS IQ Widetrack	750cc	2012	2013			5925N		
	FS Touring	750cc	2006	2006			5925N		
	FST Classic	750cc	2006	2006			5925N		
	FST IQ	750cc	2007	2007			5925N		
	FST IQ Cruiser	750cc	2007	2008			5925N		
	FST IQ LX	750cc	2007	2007			5925N		
	FST IQ Switchback			2006	2007			5925N	
	FST IQ Touring	750cc	2007	2010			5925N		
	FST SwitchBack	750cc	2006	2007			5925N		
	FST Touring	750cc	2006	2006			5925N		
	IQ Cruiser	750cc	2008	2008			5925N		
	IQ Turbo Dragon	750cc	2009	2010			5925N		
	IQ Turbo LX	750cc	2008	2008			5925N		
	Lite	339cc	1996	1998			5768N		
	Lite Deluxe	339cc	1996	1998			5768N		
	Lite GT	339cc	1996	1997			5768N		
	MSX 110	750cc	2004	2004			5925N		
	MSX 150	750cc	2004	2004			5925N		
	Sport Touring	544cc	2002	2002			PL1007N		
	Sport Touring	544cc	2002	2004			PL1001N		
	Sport Touring ES	544cc	2001	2001			PL1001N	5768N	
	Super Sport	544cc	2001	2008			PL1001N		
	Super Sport	544cc	2003	2006			PL1007N	5768N	
	Super Sport X	544cc	2003	2003				5768N	
	Trail	488cc	1996	1999				5768N	
	Trail RMK	544cc	2004	2010			PL1001N	5768N	
	Trail Touring	544cc	1996	2010				5768N	
	Trail Touring	544cc	2002	2010			PL1007N		
	Trail Touring	544cc	2005	2006			PL1001N		
	Trail Touring DLX	544cc	2005	2009				5768N	
	Turbo Dragon	750cc	2008	2008				5925N	
	Turbo IQ	750cc	2011	2012				5925N	
	Turbo IQ LX	750cc	2011	2012				5925N	
	Turbo IQ LXT	750cc	2011	2014				5925N	
	Turbo LX	750cc	2010	2010				5925N	
	Turbo SwitchBack	750cc	2008	2009				5925N	
	Ultra Touring	679cc	1997	1998				5768N	
	Wide Track IQ	750cc	2009	2010				5925N	
	Wide Track IQ 600	599cc	2010	2010				10927N	
	Wide Track LX	488cc	2011	2011				5768N	
	Wide Trak LX	488cc	1997	2015				5768N	
Wide Trak LX	488cc	2003	2014			PL1007N			
X2 800 EFI	760cc	2007	2007				18648N		
XLT Classic	597cc	1998	1999				5768N		
XLT Touring	597cc	1997	1999				5768N		

MARCA MAKE	MODELLO MODEL	CC CC	DA FROM	A TO	ALTERNATORE ALTERNATORE	REGOLATORI & RADDRIZZATORI REGULATORS & RECTIFIERS	MOTORINI AVVIAMENTO STARTER	STATORE STATOR
SKI-DOO	Alpine II	497cc	1988	1995		AS1010N		
	Alpine II	497cc	1991	1995			18871N	
	Alpine II		1988	1992			18871N	
	Alpine IV		1990	1990		AS1010N	18871N	
	Citation	248cc	1985	1988		AS1010N		
	Citation LS		1985	1988			17383N	
	Eacapade		1987	1988		AS1010N	18871N	
	Eacapade		1989	1989		AS1011N		
	Elan 250	248cc	1990	1996		AS1011N		
	Everest L/C	463cc	1983	1983		AS1010N		
	Expedition 550F	553cc	2005	2006		SK1000N		
	Expedition 550F Sport	553cc	2007	2008		SK1000N		
	Expedition LE E-TEC 600 HO	594cc	2014	2015			19496N	
	Expedition SE E-TEC 600 HO	594cc	2014	2015			19496N	
	Expedition Sport 550F	553cc	2013	2015			19496N	
	Expedition TUV 600	597cc	2005	2005			18875N	
	Expedition TUV 600HO SDI XU			2010	2010		19496N	
	Expedition TUV SE 600HO SDI XU			2010	2010		19496N	
	Formula 500	496cc	1997	1999			AS1010N	
	Formula 500	496cc	1997	2000			18871N	
	Formula 583	583cc	1997	1997			18871N	
	Formula Deluxe 380 Fan	368cc	1999	2001			18871N	
	Formula Deluxe 500	496cc	1997	1998			18871N	
	Formula Deluxe 500	496cc	2001	2001				27-7031
	Formula Deluxe 500 Fan	496cc	1999	2001			18871N	
	Formula Deluxe 500 Fan	496cc	2001	2001				27-7031
	Formula Deluxe 500 LC	496cc	1999	2000			18871N	
	Formula Deluxe 583	583cc	1998	1999			18871N	
	Formula Deluxe 600	594cc	2000	2001				27-7031
	Formula Deluxe 670	670cc	1999	1999		AS1010N	18871N	
	Formula Deluxe 700	697cc	2000	2000				27-7031
	Formula Deluxe 700		2001	2001				27-7031
	Formula Mach 1	580cc	1989	1993			AS1011N	
	Formula MX	460cc	1988	1995			AS1011N	
	Formula MX Z	460cc	1993	1993			AS1011N	
	Formula Plus	580cc	1988	1993			AS1010N	
	Formula S	580cc	2000	2000				18871N
	Formula SS	580cc	1995	1995			AS1011N	
	Formula STX	580cc	1994	1995			AS1011N	
	Formula Z	581cc	1994	1995			AS1011N	
	Formula Z 600	--L 600cc -cid	2000	2000				27-7031
	Formula Z 700	--L 700cc -cid	2000	2000				27-7031
	Freeride 154R 800RE XP			2013	2013			19496N
	Freeride E-TEC 800R 137	800cc	2013	2015				19496N
	Freeride E-TEC 800R 146	800cc	2013	2015				19496N
Freeride E-TEC 800R 154	800cc	2013	2015				19496N	
Freestyle 300F	300cc	2006	2006			SK1000N		
Freestyle Back Country 550F	553cc	2007	2009			SK1000N		
Freestyle Park 550F	553cc	2007	2008			SK1000N		

ELECTRIC PARTS SNOWMOBILE

MARCA MAKE	MODELLO MODEL	CC CC	DA FROM	A TO	ALTERNATORE ALTERNATORE	REGOLATORI & RADDRIZZATORI REGULATORS & RECTIFIERS	MOTORINI AVVIAMENTO STARTER	STATORE STATOR
SKI-DOO	Freestyle Session 300F	268cc	2007	2008		SK1000N		
	Freestyle Session 550F	553cc	2007	2007		SK1000N		
	Grand Touring 380 Fan	368cc	2002	2003			18873N	
	Grand Touring 470	470cc	1995	1995		AS1010N	18871N	
	Grand Touring 500	499cc	1996	1999		AS1010N	18871N	
	Grand Touring 500	499cc	2001	2001				27-7031
	Grand Touring 500 Fan	499cc	2002	2002			18873N	
	Grand Touring 500 Sport	499cc	2002	2003			18875N	
	Grand Touring 500 Sport	499cc	2003	2003				27-7030
	Grand Touring 550 Fan	553cc	2003	2003			18873N	
	Grand Touring 550F Sport	553cc	2010	2015			19496N	
	Grand Touring 580	581cc	1995	1996		AS1010N		
	Grand Touring 583	581cc	1997	1999		AS1010N	18871N	
	Grand Touring 600	598cc	2000	2001				27-7031
	Grand Touring 600 GS	598cc	2002	2002			18875N	
	Grand Touring 600 SE	598cc	2003	2003			18875N	27-7030
	Grand Touring 600 Sport	598cc	2003	2003			18875N	27-7030
	Grand Touring 700	697cc	1998	1999		AS1010N		
	Grand Touring 700		2001	2001				27-7031
	Grand Touring 700 GS	697cc	2002	2002			18875N	
	Grand Touring 700 SE	697cc	2003	2003			18875N	27-7030
	Grand Touring 700 Sport	697cc	2002	2003			18875N	
	Grand Touring 700 Sport	697cc	2003	2003				27-7030
	Grand Touring 800 SE	799cc	1999	1999		AS1010N		
	Grand Touring 800 SE	799cc	2002	2003			18875N	
	Grand Touring LE E-TEC 600 HO	594cc	2013	2015			19496N	
	Grand Touring SE		1995	1996			18871N	
	Grand Touring Sport 600 Carb	597cc	2013	2014			19496N	
	GSX 380 Fan	368cc	2005	2006			SK1000N	
	GSX 500F		2005	2006				18875N
	GSX 500SS Sport	499cc	2004	2006				18875N
	GSX 500SS Sport	499cc	2009	2009				19496N
	GSX 500SS Sport	597cc	2004	2007				27-7030
	GSX 500SS Sport	597cc	2008	2008				16093N
	GSX 550 Fan	553cc	2005	2009			SK1000N	
	GSX 550F Sport	553cc	2010	2010				19496N
	GSX 600	598cc	2004	2005				18875N
	GSX 600 Limited	594cc	2008	2008				16093N
	GSX 600 Limited	598cc	2009	2009				19496N
	GSX 600 Sport	598cc	2006	2006				18875N
GSX 800	799cc	2004	2005				18875N	
GSX 800 Limited	799cc	2006	2006				18875N	
GSX 800 Limited	799cc	2008	2008				16093N	
GSX LE E-TEC 600 HO	594cc	2013	2015				19496N	
GSX SE E-TEC 600 HO	594cc	2013	2015				19496N	
GSX SE E-TEC 800R	800cc	2013	2015				19496N	
GTX 380F	368cc	2005	2006			SK1000N		
GTX 500F		2005	2005				18875N	
GTX 500SS Sport	499cc	2005	2006				18875N	

MARCA MAKE	MODELLO MODEL	CC CC	DA FROM	A TO	ALTERNATORE ALTERNATORE	REGOLATORI & RADDRIZZATORI REGULATORS & RECTIFIERS	MOTORINI AVVIAMENTO STARTER	STATORE STATOR
SKI-DOO	GTX 500SS Sport	499cc	2009	2009			19496N	
	GTX 500SS Sport	597cc	2005	2008				27-7030
	GTX 550 Fan	553cc	2005	2009		SK1000N		
	GTX 600	598cc	2005	2005			18875N	27-7030
	GTX 600 Limited	598cc	2009	2009			19496N	
	GTX 800	799cc	2005	2005			18875N	
	GTX 800	799cc	2005	2007				27-7030
	GTX 800 Limited	799cc	2006	2006			18875N	
	Legend 380 Fan	368cc	2002	2003		AS1007N		
	Legend 380 Fan	368cc	2002	2004			18873N	
	Legend 500 Fan	499cc	2002	2002		AS1007N		
	Legend 500 Fan	499cc	2002	2003			18873N	
	Legend 500 Sport	499cc	2002	2004			18875N	
	Legend 500 Sport	499cc	2003	2003				27-7030
	Legend 550 Fan	553cc	2003	2003		AS1007N		
	Legend 550 Fan	553cc	2004	2004			18873N	
	Legend 600 GS	598cc	2002	2002			18875N	
	Legend 600 SE	594cc	2004	2004			18875N	
	Legend 600 SE	598cc	2003	2003			18875N	27-7030
	Legend 600 Sport	598cc	2003	2003			18875N	27-7030
	Legend 700 GS	697cc	2002	2002			18875N	
	Legend 700 SE	697cc	2003	2003			18875N	27-7030
	Legend 700 SE	698cc	2004	2004			18875N	
	Legend 700 Sport	697cc	2002	2003			18875N	
	Legend 700 Sport	697cc	2003	2003				27-7030
	Legend 800 SE	799cc	2002	2002			18875N	
	Legend 800 SE SDI	799cc	2003	2004			18875N	
	Mach 1	669cc	1994	1994		AS1011N		
	MX Z 380 Fan	368cc	2001	2001		AS1010N	18871N	
	MX Z 380 Fan	368cc	2002	2004		AS1007N		
	MX Z 380 Fan	368cc	2002	2006			18873N	
	MX Z 440 Fan	436cc	2001	2001			18871N	
	MX Z 440 X	436cc	2003	2005		AS1007N		
	MX Z 440 X	436cc	2006	2007				27-7030
	MX Z 440 X		1999	1999				27-7031
	MX Z 500	499cc	2000	2002				27-7031
	MX Z 500 Adrenaline	499cc	2003	2003				27-7030
	MX Z 500 Adrenaline	499cc	2003	2005			18875N	
	MX Z 500 Fan	499cc	2001	2001			18871N	27-7031
	MX Z 500 Fan	499cc	2002	2002		AS1007N	18873N	
	MX Z 500 Trail	499cc	2003	2003				27-7030
	MX Z 500 Trail	499cc	2003	2006			18875N	
	MX Z 500 Trail	499cc	2009	2009			19496N	
MX Z 500 Trial	597cc	2008	2008			16093N		
MX Z 50th Anniversary			2009	2009			19496N	
MX Z 550 Fan	552cc	2003	2003			18873N		
MX Z 550 Fan	552cc	2003	2004		AS1007N			
MX Z 550 Fan	552cc	2004	2006			18875N		
MX Z 550 Fan	552cc	2007	2008		SK1000N			

ELECTRIC PARTS SNOWMOBILE

MARCA MAKE	MODELLO MODEL	CC CC	DA FROM	A TO	ALTERNATORE ALTERNATORE	REGOLATORI & RADDRIZZATORI REGULATORS & RECTIFIERS	MOTORINI AVVIAMENTO STARTER	STATORE STATOR	
SKI-DOO	MX Z 550 X	552cc	2007	2008		SK1000N			
	MX Z 550F TNT	552cc	2010	2010			19496N		
	MX Z 550SS TNT	553cc	2008	2008			16093N		
	MX Z 550SS TNT		2009	2009			19496N		
	MX Z 600	597cc	1999	2002				27-7031	
	MX Z 600 Adrenaline	597cc	2003	2006			18875N		
	MX Z 600 Adrenaline	597cc	2009	2009			19496N		
	MX Z 600 Adrenaline	594cc	2008	2008			16093N		
	MX Z 600 Adrenaline HO SDI			2005	2006			18875N	
	MX Z 600 Renegade	597cc	2003	2003				27-7030	
	MX Z 600 Renegade	597cc	2003	2006			18875N		
	MX Z 600 Renegade	597cc	2009	2009			19496N		
	MX Z 600 Renegade X	594cc	2004	2004			18875N	27-7030	
	MX Z 600 Renegade X	597cc	2006	2006			18875N		
	MX Z 600 Renegade X	597cc	2008	2008			16093N		
	MX Z 600 Renegade X	597cc	2009	2009			19496N		
	MX Z 600 Renegade X	600cc	2005	2005			18875N		
	MX Z 600 Sport	597cc	2003	2003			18875N	27-7030	
	MX Z 600 TNT	597cc	2009	2009			19496N		
	MX Z 600 Trail	597cc	2003	2005			18875N	27-7030	
	MX Z 600 X	594cc	2004	2004				27-7030	
	MX Z 600 X	594cc	2008	2008			16093N		
	MX Z 600 X	597cc	2001	2002				27-7031	
	MX Z 600 X	597cc	2001	2006			18875N		
	MX Z 600 X	597cc	2003	2003				27-7030	
	MX Z 600 X	597cc	2009	2009			19496N		
	MX Z 600 X-RS			2009	2009			19496N	
	MX Z 700	697cc	1999	2002				27-7031	
	MX Z 700 Adrenaline	697cc	2003	2003			18875N	27-7030	
	MX Z 700 X	697cc	2001	2002				27-7031	
	MX Z 800	797cc	2000	2002				27-7031	
	MX Z 800 Adrenaline	797cc	2003	2006			18875N		
	MX Z 800 Adrenaline	797cc	2003	2007				27-7030	
	MX Z 800 Adrenaline R	799cc	2008	2008			16093N		
	MX Z 800 Adrenaline R			2009	2009			19496N	
	MX Z 800 R X	800cc	2008	2008			16093N		
	MX Z 800 Renegade	797cc	2003	2006			18875N		
	MX Z 800 Renegade	797cc	2003	2007				27-7030	
	MX Z 800 Renegade	797cc	2009	2009			19496N		
	MX Z 800 Renegade	797cc	2008	2008			16093N		
	MX Z 800 Renegade X	797cc	2004	2007				27-7030	
	MX Z 800 Renegade X	797cc	2008	2008			16093N		
	MX Z 800 Sport	797cc	2003	2003			18875N	27-7030	
	MX Z 800 X	797cc	2001	2003			18875N		
	MX Z 800 X	797cc	2003	2003				27-7030	
	MX Z 800R Renegade X			2009	2009			19496N	
	MX Z Iron Dog E-TEC 600 HO			2015	2015			19496N	
MX Z Iron Dog E-TEC 800R			2015	2015			19496N		
MX Z REV 007 Bond Special ED			2003	2003			18875N		

MARCA MAKE	MODELLO MODEL	CC CC	DA FROM	A TO	ALTERNATORE ALTERNATORE	REGOLATORI & RADDRIZZATORI REGULATORS & RECTIFIERS	MOTORINI AVVIAMENTO STARTER	STATORE STATOR	
SKI-DOO	MX Z Sport 550F	553cc	2013	2014			19496N		
	MX Z Sport 600 Carb	597cc	2013	2015			19496N		
	MX Z TNT E-TEC 600 HO	594cc	2013	2015			19496N		
	MX Z TNT E-TEC 800R	800cc	2013	2015			19496N		
	MX Z Trail			2009	2009			19496N	
	MX Z X E-TEC 600 HO	594cc	2013	2015			19496N		
	MX Z X E-TEC 800R	800cc	2013	2015			19496N		
	MX Z X-RS E-TEC 600 HO	594cc	2013	2015			19496N		
	MX Z X-RS E-TEC 800R	800cc	2013	2015			19496N		
	MX ZX 600 HO SDI			2006	2006			18875N	
	Nordik 50	436cc	1988	1991			AS1011N		
	Nordik 60	496cc	1988	1991			AS1011N		
	Renegade 550F Sport	550cc	2010	2010				19496N	
	Renegade Adrenaline E-TEC 600 HO	594cc	2013	2015				19496N	
	Renegade Adrenaline E-TEC 800R	800cc	2013	2015				19496N	
	Renegade Backcountry E-TEC 600 HO	594cc	2013	2015				19496N	
	Renegade Backcountry E-TEC 800R	800cc	2013	2015				19496N	
	Renegade Backcountry X E-TEC 600 HO	594cc	2013	2015				19496N	
	Renegade Backcountry X E-TEC 800R	800cc	2013	2015				19496N	
	Renegade Sport 550F	553cc	2013	2014				19496N	
	Renegade X E-TEC 600 HO	594cc	2013	2015				19496N	
	Renegade X E-TEC 800R	800cc	2013	2015				19496N	
	Safari 377	368cc	1984	1986			AS1010N	18871N	
	Safari 377	377cc	1987	1988			AS1011N		
	Safari 503	500cc	1988	1988			AS1010N	18871N	
	Safari Chyenne	496cc	1989	1990			AS1011N		
	Safari Citation	248cc	1989	1990			AS1010N	17383N	
	Safari Deluxe	368cc	1993	1994			AS1010N	18871N	
	Safari Escapade	368cc	1989	1989			AS1010N	18871N	
	Safari GLX	463cc	1990	1992			AS1010N	18871N	
	Safari L	463cc	1990	1994			AS1010N		
	Safari LC	463cc	1990	1990			AS1010N	18871N	
	Safari LCE	463cc	1991	1992			AS1010N	18871N	
	Safari LE	463cc	1990	1992			AS1010N	18871N	
	Safari LX	499cc	1990	1991			AS1010N	18871N	
	Safari LXE	499cc	1990	1991			AS1010N	18871N	
	Safari Rally	499cc	1993	1993				18871N	
	Safari Rally E	499cc	1994	1994			AS1010N	18871N	
	Safari Saga	499cc	1989	1989			AS1010N	18871N	
	Safari Scout	499cc	1989	1990			AS1010N	18871N	
	Safari Voyageur	499cc	1989	1989			AS1010N	18871N	
	Scandic LT 440			2001	2007			18871N	
	Scandic Super Wide Track 500			1997	2000			17383N	
	Scandic Super Wide Track 500			2001	2003			18871N	
	Scandic Wide Track 500			1995	2000			17383N	
	Scandic Wide Track 500			2001	2003			18871N	
	Scandic Wide Track LC			1996	2000			18871N	
Skandic 500			2001	2002				27-7031	
Skandic 500			2003	2003		AS1007N			

ELECTRIC PARTS SNOWMOBILE

MARCA MAKE	MODELLO MODEL	CC CC	DA FROM	A TO	ALTERNATORE ALTERNATORE	REGOLATORI & RADDRIZZATORI REGULATORS & RECTIFIERS	MOTORINI AVVIAMENTO STARTER	STATORE STATOR
SKI-DOO	Skandic 500 SWT	497cc	1997	2001		AS1010N		
	Skandic 500 SWT	497cc	2001	2002				27-7031
	Skandic 500 WT	497cc	2001	2002				27-7031
	Skandic 500 WT	497cc	2001	2003			18871N	
	Skandic 500 WT		2015	2015			19496N	
	Skandic 503	497cc	1987	1987		AS1010N	18871N	
	Skandic 550F SUV	553cc	2004	2004		AS1007N		
	Skandic 550F SUV	553cc	2004	2007			18873N	
	Skandic 550F SUV	553cc	2008	2010		SK1000N	18871N	
	Skandic 550F SWT	553cc	2004	2007			18873N	
	Skandic 550F SWT	553cc	2008	2009			18871N	
	Skandic 550F SWT		2014	2014			19496N	
	Skandic 550F WT	553cc	2004	2007			18873N	
	Skandic 550F WT	553cc	2008	2010			18871N	
	Skandic 550F WT	553cc	2014	2014			19496N	
	Skandic 550F WT		2011	2011			18871N	
	Skandic 600 SUV	597cc	2003	2006			18875N	
	Skandic 600 SUV	597cc	2008	2008		SK1000N		
	Skandic 600 WT	597cc	2002	2002				27-7031
	Skandic 600 WT	597cc	2002	2006			18875N	
	Skandic 600 WT	597cc	2008	2010				27-7030
	Skandic 600 WT		2001	2001				27-7031
	Skandic II	368cc	1992	1993			AS1011N	
	Skandic II 503R	499cc	1993	1994			AS1011N	
	Skandic SWT		2008	2008			SK1000N	
	Skandic SWT ACE 600	600cc	2014	2014				19496N
	Skandic Tundra	553cc	2010	2010				19496N
	Skandic Tundra 300F		2007	2009			SK1000N	
	Skandic Tundra 550F		2008	2009			SK1000N	
	Skandic WT 550 Fan	594cc	2011	2011			SK1000N	
	Skandic WT 550 Fan		2008	2010			SK1000N	
	Skandic WTE-TEC 600 HO	594cc	2014	2014				19496N
	Stratos	499cc	1987	1987			AS1010N	18871N
	Summit 470	463cc	1994	1994			AS1011N	
	Summit 500		2002	2002			AS1007N	
	Summit 550 Fan	553cc	2003	2003				18873N
	Summit 550 Fan	553cc	2003	2004			AS1007N	
	Summit 550 Fan	553cc	2005	2005			SK1000N	
	Summit 583	583cc	1994	1995			AS1011N	
	Summit 600	598cc	1999	2002				27-7031
	Summit 600 Adrenaline	598cc	2003	2004				27-7030
	Summit 600 X		2009	2009				19496N
Summit 670	669cc	1995	1995			AS1011N		
Summit 700	697cc	2000	2002				27-7031	
Summit 700		1999	1999				27-7031	
Summit 700 Adrenaline	697cc	2003	2003				27-7030	
Summit 700 Highmark	697cc	2003	2003				27-7030	
Summit 700 X	697cc	2003	2003				27-7030	
Summit 800	799cc	2001	2001				27-7031	

MARCA MAKE	MODELLO MODEL	CC CC	DA FROM	A TO	ALTERNATORE ALTERNATORE	REGOLATORI & RADDRIZZATORI REGULATORS & RECTIFIERS	MOTORINI AVVIAMENTO STARTER	STATORE STATOR	
SKI-DOO	Summit 800		2000	2002				27-7031	
	Summit 800 Adrenaline 144	799cc	2005	2006			18875N		
	Summit 800 X	799cc	2008	2008			16093N		
	Summit 800 X		2009	2009			19496N		
	Summit Everest 500SS		2009	2009			19496N		
	Summit Everest 600HO		2009	2009			19496N		
	Summit Everest 800R	799cc	2008	2008			16093N		
	Summit Everest 800R		2009	2009			19496N		
	Summit SP E-TEC 600 HO 146	594cc	2013	2015			19496N		
	Summit SP E-TEC 600 HO 154	594cc	2013	2015			19496N		
	Summit SP E-TEC 800R 146	800cc	2013	2015			19496N		
	Summit SP E-TEC 800R 154	800cc	2013	2015			19496N		
	Summit SP E-TEC 800R 163	800cc	2013	2015			19496N		
	Summit Sport 600 Carb	597cc	2013	2014			19496N		
	Summit Sport Power TEK 800R	800cc	2014	2014			19496N		
	Summit X E-TEC 800R 146	800cc	2013	2015			19496N		
	Summit X E-TEC 800R 154	800cc	2013	2015			19496N		
	Summit X E-TEC 800R 163	800cc	2013	2015			19496N		
	Touring 380 Fan	368cc	2001	2001			18871N		
	Touring 500 Fan	499cc	2001	2001			18871N		
	Touring 500 LC	499cc	2000	2000			18871N		
	Touring E	368cc	1995	2000			18871N		
	Touring LE	437cc	1995	2000			18871N		
	Touring SLE	497cc	1995	2000			18871N		
	Tundra	248cc	1986	1992			17383N		
	Tundra	248cc	1987	1987		AS1010N			
	Tundra	248cc	1988	1992		AS1011N			
	Tundra Extreme E-TEC 600 HO	600cc	2013	2015			19496N		
	Tundra LT 550F	553cc	2013	2015			19496N		
	Tundra Sport 550F	553cc	2013	2015			19496N		
	Tundra WT 550F RER		2015	2015			19496N		
	YAMAHA	BR250 Bravo	246cc	1982	1987		YM1031N		
		BR250 Bravo	246cc	1988	1993		YM1037N		
		BR250T Bravo	246cc	2007	2011		YM1037N		
BR250T Bravo LT		246cc	1990	2000		YM1037N			
BW200		196cc	1985	1986		YM1031N			
CF300 Inviter		292cc	1989	1990		YM1037N			
CS340E Ovation LE		340cc	1994	2000			18890N		
EC340		338cc	1981	1983		YM1031N			
EC340 Excel III		338cc	1984	1987		YM1031N			
EC340 Excel III		338cc	1988	1988		YM1037N			
EC540		535cc	1979	1980		YM1031N			
ET250		246cc	1978	1981		YM1031N			
ET300		292cc	1979	1980		YM1031N			
ET300 Enticer 300		292cc	1983	1984		YM1031N			
ET340		338cc	1978	1980		YM1031N			
ET340 Enticer 340		338cc	1984	1987		YM1031N			
ET340T Enticer 340T		338cc	1982	1987		YM1031N			
ET340T Enticer 340T		338cc	1988	1988		YM1037N			

ELECTRIC PARTS SNOWMOBILE

MARCA MAKE	MODELLO MODEL	CC CC	DA FROM	A TO	ALTERNATORE ALTERNATORE	REGOLATORI & RADDRIZZATORI REGULATORS & RECTIFIERS	MOTORINI AVVIAMENTO STARTER	STATORE STATOR
YAMAHA	ET400TR Enticer LTR	400cc	1988	1990		YM1037N		
	EX340	338cc	1978	1978		YM1031N		
	EX440	437cc	1978	1981		YM1031N		
	EX570 Exciter	570cc	1988	1990		YM1037N		
	EX570E Exciter II LE	570cc	1991	1993		YM1037N		
	EX570E Exciter LE	570cc	1990	1990		YM1037N		
	EX570ST Exciter II ST	570cc	1993	1993		YM1037N		
	EX570SX Exciter II SX	570cc	1993	1993		YM1037N		
	FX10 FX Nytro	1049cc	2011	2014			18892N	
	FX10 FX Nytro	998cc	2008	2010			18892N	
	FX10M FX Nytro MTX 153	1049cc	2012	2014			18892N	
	FX10M FX Nytro MTX 162	1049cc	2012	2014			18892N	
	FX10M FX Nytro MTX SE 153	1049cc	2010	2014			18892N	
	FX10MT FX Nytro MTX	998cc	2008	2010			18892N	
	FX10MTR FX Nytro MX	998cc	2008	2008			18892N	
	FX10MTRA FX Nytro MTX 40th Anniv	998cc	2008	2008			18892N	
	FX10MTS FX Nytro MTX SE 162	1049cc	2011	2011			18892N	
	FX10MTS FX Nytro MTX SE 162	998cc	2010	2010			18892N	
	FX10RT FX Nytro RTX Non- Reverse	1340cc	2008	2008			18892N	
	FX10RTR FX Nytro RTX	1049cc	2011	2013			18892N	
	FX10RTR FX Nytro RTX	998cc	2008	2010			18892N	
	FX10RTRA FX Nytro RTX 40th Anniv	998cc	2008	2008			18892N	
	FX10RTRS FX Nytro RTX SE	998cc	2009	2010			18892N	
	FX10XT FX Nytro XTX	1049cc	2011	2012			18892N	
	FX10XT FX Nytro XTX	998cc	2009	2010			18892N	
	FX10XT FX Nytro XTX 1.75	1049cc	2013	2014			18892N	
	MM600 Mountain Max 600	599cc	1997	2002			18891N	
	MM700 Mountain Max 700	698cc	1997	2003			18891N	
	MM800 Mountain Max 800	798cc	1997	1997		YM1037N		
	MSRX700 Mountain SRX 700	798cc	1998	1998		YM1037N		
	PZ480 Phazer	480cc	1988	1989		YM1037N		
	PZ480 Phazer II	480cc	1990	1996		YM1037N		
	PZ480 Phazer SS	480cc	1997	1998		YM1037N		
	PZ480E Phazer II LE	480cc	1990	1991		YM1037N		
	PZ480E Phazer II LE	480cc	1996	1996			18890N	
	PZ480E Phazer SS Electric	480cc	1997	1998		YM1037N	18890N	
	PZ480ST Phazer II ST	480cc	1991	1995			18890N	
	PZ480ST Phazer II ST	480cc	1991	1991		YM1037N		
	PZ480ST Phazer Mountain Lite	480cc	1996	1999			18890N	
	PZ500 Phazer 500	499cc	1999	2001			18891N	
	PZ500DX Phazer Deluxe	499cc	2001	2001			18891N	
	PZ500ML Phazer Mountain Lite	499cc	2000	2001			18891N	
	RS Venture GT	973cc	2007	2010			18892N	
	RS10 RS Venture TF	1049cc	2013	2014			18892N	
	RS90 RS Vector	973cc	2005	2006			18892N	
RS90GT Vector GT	1049cc	2011	2011			18892N		
RS90GT Vector GT	973cc	2006	2010			18892N		
RS90GTA RS Vector 40th Anniv	973cc	2008	2008			18892N		
RS90L RS Vector LE	1049cc	2016	2016			18892N		

MARCA MAKE	MODELLO MODEL	CC CC	DA FROM	A TO	ALTERNATORE ALTERNATORE	REGOLATORI & RADDRIZZATORI REGULATORS & RECTIFIERS	MOTORINI AVVIAMENTO STARTER	STATORE STATOR	
YAMAHA	RS90LT RS Vector LTX	1049cc	2012	2014			18892N		
	RS90LT RS Vector LTX	973cc	2008	2009			18892N		
	RS90LTGT RS Vector LT GT	973cc	2009	2009			18892N		
	RS90LTGT RS Vector LTX GT	1049cc	2011	2011			18892N		
	RS90LTGT RS Vector LTX GT	973cc	2008	2010			18892N		
	RS90M RS Vector Mountain	973cc	2005	2007			18892N		
	RS90MS RS Vector Mountain SE	973cc	2006	2007			18892N		
	RS90N Nytro	973cc	2006	2007			18892N		
	RS90NR Nytro ER	973cc	2006	2007			18892N		
	RS90P RS Vector	1049cc	2015	2015			18892N		
	RS90P RS Vector LTX			2013	2015			18892N	
	RS90R RS Vector	1049cc	2012	2014			18892N		
	RS90R RS Vector	973cc	2008	2009			18892N		
	RS90R RS Vector ER	973cc	2005	2007			18892N		
	RS90XT RS Vector XTX	1049cc	2016	2016			18892N		
	RS90XT RS Vector XTX 1.75			2016	2016			18892N	
	RS90XT RS Vector XTX LE			2016	2016			18892N	
	RSG90 RS Rage	973cc	2005	2007			18892N		
	RSG90GT RS Rage GT	973cc	2007	2007			18892N		
	RST90 RS Venture	973cc	2005	2016			18892N		
	RST90GT RS Venture GT	1049cc	2009	2015			18892N		
	RST90GT RS Venture GT	973cc	2007	2008			18892N		
	RST90P RS Venture TF			2015	2016			18892N	
	RST90TF RS Venture TF E-Bat			2016	2016			18892N	
	RST90TF RS Venture TF LE			2016	2016			18892N	
	RX10GT Apex GT	998cc	2006	2010			16092N		
	RX10GTA Apex GT 40th Anniv	998cc	2008	2008			16092N		
	RX10L Apex LE	998cc	2016	2016			16092N		
	RX10LT Apex LTX	998cc	2008	2010			16092N		
	RX10LTGT Apex LTX GT	998cc	2008	2010			16092N		
	RX10LTGTA Apex LTX GT 40th Anniv	998cc	2008	2008			16092N		
	RX10M Apex Mountain	998cc	2006	2007			16092N		
	RX10MS Apex Mountain SE	998cc	2007	2007			16092N		
	RX10MT Apex MTX	998cc	2008	2010			16092N		
	RX10MTA Apex MTX SE 40th Anniv	998cc	2008	2008			16092N		
	RX10PS Apex SE	998cc	2011	2015			16092N		
	RX10PX Apex XTX	998cc	2011	2015			16092N		
	RX10R Apex	998cc	2008	2016			16092N		
	RX10R Apex ER	998cc	2006	2007			16092N		
	RX10RT Apex RTX	998cc	2006	2009			16092N		
	RX10RTR Apex RTX ER	998cc	2007	2008			16092N		
	RX10X Apex XTX 1.75 LE			2015	2015			16092N	
	RX10XT Apex XTX			2015	2015			16092N	
	RX10XT Apex XTX 1.75			2015	2015			16092N	
	RXW10 Attack	998cc	2006	2007			16092N		
RXW10GT Attack GT	998cc	2007	2007			16092N			
SR Viper	1049cc	2014	2014			18892N			
SR Viper LTX	1049cc	2014	2014			18892N			
SR Viper LTX DX			2015	2015			18892N		

MARCA MAKE	MODELLO MODEL	CC CC	DA FROM	A TO	ALTERNATORE ALTERNATORE	REGOLATORI & RADDRIZZATORI REGULATORS & RECTIFIERS	MOTORINI AVVIAMENTO STARTER	STATORE STATOR
YAMAHA	SR Viper LTX LE 1.75		2015	2015			18892N	
	SR Viper LTX SE	1049cc	2014	2015			18892N	
	SR Viper MTX 153		2015	2015			18892N	
	SR Viper MTX 153 SE		2015	2015			18892N	
	SR Viper MTX 162 LE		2015	2015			18892N	
	SR Viper MTX 162 SE		2015	2015			18892N	
	SR Viper RTX		2014	2014			18892N	
	SR Viper RTX DX		2015	2015			18892N	
	SR Viper RTX LE		2015	2015			18892N	
	SR Viper RTX SE	1049cc	2014	2014			18892N	
	SR Viper RTX SE		2015	2015			18892N	
	SR Viper STX DX		2015	2015			18892N	
	SR Viper XTX LE		2015	2015			18892N	
	SR Viper XTX SE	1049cc	2014	2015			18892N	
	SR540 SRV	538cc	1988	1990			YM1037N	
	SRX600		1998	1999			YM1037N	
	SRX700	698cc	1998	1999			YM1037N	
	SRX700	698cc	1998	2002				18891N
	SX500/R	500cc	2000	2001				18891N
	SX600/R	593cc	2000	2003				18891N
	SX700/R	696cc	2000	2001				18891N
	SX700S	696cc	2000	2000				18891N
	SXV60 SX Venom	593cc	2004	2006			YM1034N	18891N
	SXV60ER SX Venom ER	593cc	2004	2006			YM1034N	18891N
	SXV700 SX Viper	696cc	2002	2004				18891N
	SXV700 SX Viper	696cc	2003	2004			YM1034N	
	SXV700ER SX Viper ER	696cc	2002	2004				18891N
	SXV700ER SX Viper ER	696cc	2003	2004			YM1034N	
	SXV70MH SX Viper Mountain	696cc	2003	2006			YM1034N	18891N
	VK10 Viking Professional	973cc	2006	2015				18892N
	VK540 II	540cc	1994	1998				18890N
	VK540 III	540cc	1999	2005				18890N
	VK540E VK540 III		1989	2005			YM1037N	
	VT480 Venture XL	480cc	1991	1997				18890N
	VT480TR Venture TR	480cc	1996	1998				18890N
	VT500 Venture 500	498cc	1997	2001				18891N
	VT500XL Venture 500 XL	498cc	1999	2001				18891N
	VT600 Venture 600	593cc	1997	2006				18891N
	VT600 Venture 600	593cc	2004	2006			YM1034N	
	VT700 Venture 700	696cc	1998	2004				18891N
	VT700 Venture 700	696cc	2004	2004			YM1034N	
	VX500 VMAX 500	498cc	1994	2000				18890N
	VX500 VMAX 500	498cc	2001	2001				18891N
	VX500DX VMAX 500 Deluxe	498cc	2000	2001				18891N
	VX500DX VMAX 500 DX	498cc	1994	1996				18890N
	VX500E VAMX 500 LE	498cc	1994	1996				18890N
VX500ER	498cc	1999	1999				18891N	
VX500ST VMAX 500 ST	498cc	1994	1994				18890N	
VX500SX VMAX 500 SX	498cc	1999	1999				18891N	

MARCA MAKE	MODELLO MODEL	CC CC	DA FROM	A TO	ALTERNATORE ALTERNATORE	REGOLATORI & RADDRIZZATORI REGULATORS & RECTIFIERS	MOTORINI AVVIAMENTO STARTER	STATORE STATOR
YAMAHA	VX500XT VMAX 500 XT	498cc	1997	1998			18891N	
	VX500XTC VMAX 500 XTC	498cc	1997	1998			18891N	
	VX500XTCD VMAX 500 XTC Deluxe	498cc	1998	1998			18891N	
	VX500XTR VMAX 500 XTR	498cc	1998	1998			18891N	
	VX500XTW VMAX 500 XT Proaction Plus	498cc	1996	1996			18891N	
	VX600 VMAX 600	593cc	1994	1997			18890N	
	VX600 VMAX 600	593cc	1999	1999			18891N	
	VX600DX VMAX 600 Deluxe	593cc	2000	2001			18891N	
	VX600DX VMAX 600 DX	593cc	1994	1996			18890N	
	VX600E VMAX 600 LE	593cc	1994	1996			18890N	
	VX600ER VMAX 600 ER	593cc	2002	2003			18891N	
	VX600ST VMAX 600 Mountain Max	593cc	1996	1996		YM1037N	18890N	
	VX600ST VMAX 600 ST	593cc	1994	1995			18890N	
	VX600SX VMAX 600 SX	593cc	1997	1999			18891N	
	VX600SXS VMAX 600 SXS	593cc	1998	1998			18891N	
	VX600XT VMAX 600 XT	593cc	1997	1998			18891N	
	VX600XTC VMAX 600 XTC	593cc	1997	1998			18891N	
	VX600XTC VMAX 600 XTC (Reverse)	593cc	1997	1997			18891N	
	VX600XTCD VMAX 600 XTC Deluxe	593cc	1998	1998			18891N	
	VX600XTR VMAX 600 XTR	593cc	1998	1998			18891N	
	VX600XTW VMAX 600 XT Proaction Plus	593cc	1996	1996			18890N	
	VX700 VMAX 700	696cc	1999	2001			18891N	
	VX700DX VMAX 700 Deluxe	696cc	1999	2001			18891N	
	VX700ER VMAX 700 ER	696cc	2002	2002			18891N	
	VX700SX VMAX 700 SX	696cc	1997	1999			18891N	
	VX700SXS VMAX 700 SXS	696cc	1998	1998			18891N	
	VX700XT VMAX 700 XT	696cc	1998	1998			18891N	
	VX700XTC VMAX 700 XTC	696cc	1998	1998			18891N	
	VX700XTCD VMAX 700 XTC Deluxe	696cc	1998	1998			18891N	
	VX700XTCP VMAX 700 XTCP	696cc	1998	1998			18891N	
	VX800 VMAX-4 800	800cc	1995	1997			YM1037N	
	XV1600A Road Star	1602cc	2003	2003			YM1034N	
	XV1600AS Road Star Midnight	1602cc	2001	2003			YM1034N	
	XVS1100 V Star 1100 Custom	1063cc	2000	2001			YM1034N	
	XVS1100A V Star 1100 Classic	1063cc	2000	2002			YM1034N	
	XVS650 V Star Custom	649cc	1998	2000			YM1034N	
	XVS650A V Star Classic	649cc	1999	2000			YM1034N	
	YFM660F Grizzly 4x4	660cc	2001	2008			YM1034N	
	YFM700R Raptor	686cc	2006	2014			YM1034N	
	YFS200 Blaster	195cc	1988	2006			YM1031N	
YFZ350 Banshee	347cc	1987	2006			YM1031N		
YFZ450R	449cc	2009	2014			YM1034N		



A black and white photograph of a person riding an ATV through a wooded area. The image is tilted at an angle, creating a sense of motion and adventure. The rider is wearing a helmet and protective gear. The background consists of trees and foliage, which are slightly blurred to emphasize the speed of the ride.

***DISCHI FRENO TRW
ATV - UTV***

DISCHI FRENO TRW ATV - UTV

MARCA	TIPO	CC	MODELLO	ANNO	CODICE VEICOLO
MAKE	TYPE	CC	MODEL	YEARS	VEHICLE CODE
ARCTIC CAT	DVX	50		06-	DVX50
	DVX	90		06-	DVX90
BOMBARDIER	DS	650	Baja X	00-06	A
DERBI	DXR	200		04-	SM
	DXR	250		04-	SM
HONDA	TRX	250	EX	01-08	TRX250
	TRX	400	EX Fourtrax	99-02	TE23
	TRX	400	EX Sporttrax	99-08	TE23
	TRX	300	EX Sporttrax	93-	TE19
	TRX	450	R, ER	04-	TE22
KAWASAKI	TRX	250	X	87-92	TE13
	KVF	650	Brute Force	04-11	KVF650D
	KVF	650	Brute Force	12-	KVF650G
	KVF	650	Brute Force	12-	KVF650H
	KVF	700	Brute Force	04-06	KVF700
	KVF	750	Brute Force	05-11	KVF750D
	KVF	750	Brute Force	12-11	KVF750F
	KVF	360	Prairie	03-13	VF360A
	KVF	650	Prairie	01-03	KVF650
	KFX	400		03-	AK47B
	KFX	450		07-	SF450B
	KFX	700		07-	SV700A
KTM	XC	450		08-	
	XC	505		08-	
KYMCO		125	Mxer	02-	L1
		150	Mxer	02-	L1
SUZUKI	LTA	700	King Quad	05-07	LTA 700
	LTA	750	King Quad	05-	LTA750
	LTZ	400	Quad Sport	02-	LTZ400
	LT	250	Quadracer, Quad Sport	85-92	LTZ250
YAMAHA	LTR	450		06-	LTR450
	YZF	350	Banshee	87-06	YZF350
	YFM	250	Big Bear	07-	YFM250
	YFS	200	Blaster	06-	YFS200
	YFS	200	Blaster	88-05	YFS200
	YFM	250	Bruin	05-	YFM250
	YFM	400	Grizzly	07	YFM400
	YFM	700	Grizzly	07-	YFM700
	YFM	400	Kodiak	00-02	AJ03
	YFM	250	Raptor	08-	YFM250
	YFM	350	Raptor	04-	YFM350
	YFM	660	Raptor	01-05	AM01
	YFM	700	Raptor	06-	AM07
	YFM	350	Warrior	92-04	YFM350
	YFM	350	Wolverine	95-06	YFM350
YFM	250	X	01-04	YFM250	
YFZ	450		04-05	AJ11	
YFZ	450		06-10	YFZ450	

DISCO ANTERIORE	DIAMETRO	SET BULLONI ANTERIORI	DISCO POSTERIORE	DIAMETRO	SET BULLONI POSTERIORI
FRONT DISC	DIAMETER	FRONT SCREW KIT	REAR DISC	DIAMETER	REAR SCREW KIT
MST 256	180		MST 256	180	
MST 256	180		MST 256	180	
MST 400	165		MST 401	196	
MST 405	161		MST 407	220	
MST 405	161		MST 407	220	
MST 403	174	MSS 126-3			
MST 403	174	MSS 126-3	MST 245	220	MSS 126-4
MST 403	174	MSS 126-3	MST 245	220	MSS 126-4
MST 403	174	MSS 126-3	MST 404	220	
MST 403	174	MSS 126-3			
MST 403	174	MSS 126-3			
MST 415	200				
MST 415	200				
MST 415	200				
MST 415	200				
MST 415	200				
MST 415	200				
MST 415	200				
MST 415	200				
MST 402	160		MST 323	220	
MST 408	163		MST 413	200	
MST 408	163				
MST 384	180		MST 385	200	
MST 384	180		MST 385	200	
MST 256	180		MST 256	180	
MST 256	180		MST 256	180	
MST 414	200				
MST 414	200				
MST 402	160	MSS 114-3	MST 323	220	MSS 114-3
MST 402	160				
MST 411	160	MSS 114-3	MST 412	190	MSS 114-3
MST 405	161		MST 407	220	MSS 128-4
MST 405	161				
MST 405	161		MST 407	220	MSS 128-4
MST 405	161		MST 407	220	MSS 128-4
MST 405	161				
MST 405	161				
MST 416	220		MST 417	205	
MST 257	180				
MST 405	161				
MST 405	161				
MST 405	161		MST 407	220	MSS 128-4
MST 405	161		MST 410	200	
MST 405	161		MST 406	245	MSS 128-4
MST 405	161		MST 407	220	MSS 128-4
MST 405	161				
MST 405	161				
MST 405	161		MST 410	200	

DISCHI FRENO
TRW ATV - UTV





***PASTIGLIE TRW FRENO
ATV - UTV***

PASTIGLIE FRENO TRW ATV - UTV

MARCA	MODELLO	CC	TELAIO	ANNO	NOTE	DOPPO DISCO	PASTIGLIE ANT	TIPO 1	TIPO 2	PASTIGLIE POST	TIPO '1	TIPO '2	NOTE'	
MAKE	MODEL	CC	VIN	YEARS	NOTE	DOUBLE DISC	FRONT PAD	TYPE 1	TYPE 2	REAR PAD	TYPE '1	TYPE '2	NOTE'	
ADLY (HER CHEE)	Buffalo	300		05-06		*	MCB 517			MCB 517				
	Canyon	280		07-09	Herkules	*	MCB 760 SI			MCB 805 SI			Herkules	
	Canyon, SE	320		07-	Herkules	*	MCB 760 SI			MCB 805 SI			Herkules	
	Crossover	150		05-09		*	MCB 519 SI	EC		MCB 519 SI	EC			
	Crossover	300		05-09		*	MCB 760 SI			MCB 805 SI				
	Crossroad	150		06-10		*	MCB 519 SI	EC		MCB 519 SI	EC			
	Crossroad	300		05-10		*	MCB 760 SI			MCB 805 SI				
	Crossroad Sentinel	150		06-10		*	MCB 760 SI			MCB 805 SI				
	Hurricane	320		07-	Herkules	*	MCB 760 SI			MCB 805 SI			Herkules	
	Hurricane	280		07-	Herkules	*	MCB 760 SI			MCB 805 SI			Herkules	
	Hurricane S Flat	320		07-	Herkules	*	MCB 760 SI			MCB 805 SI			Herkules	
	Hurricane XS	300		07-	Herkules	*	MCB 760 SI			MCB 805 SI			Herkules	
	Hurricane XS	400		13-	Herkules	*	MCB 760 SI			MCB 805 SI			Herkules	
	Interceptor	150		05-		*	MCB 519 SI	EC		MCB 519 SI	EC			
	Interceptor	300		07-	Herkules	*	MCB 519 SI	EC		MCB 519 SI	EC		Herkules	
	S Hurricane	500		08-	Herkules	*	MCB 760 SI			MCB 805 SI			Herkules	
	Sport	150		04-09		*	MCB 519 SI	EC		MCB 519 SI	EC			
	Sport	300		07-		*	MCB 760 SI			MCB 805 SI				
	AEON	Super Sonic	50		00-			MCB 519	EC	SR	MCB 519	EC	SR	
		Super Sonic	125		01-			MCB 519	EC	SR				
Utility		300		04-09		*	MCB 760 SI			MCB 805 SI				
Cobra		220		05-12		*	MCB 519 SI	EC		MCB 523 SI				
Cobra		320		08-		*	MCB 519 SI			MCB 582 SI				
Cobra		350		09-		*	MCB 519 SI			MCB 582 SI				
Cobra		400		10-		*	MCB 519 SI			MCB 519 SI	EC			
Crossland		350		11-		*	MCB 519 SI			MCB 615 SI				
Crossland		400		12-		*	MCB 519 SI			MCB 582 SI				
Overland		125		02-						MCB 615 SI	EC			
Overland		180		02-						MCB 615 SI	EC			
Overland		300		06-		*	MCB 519 SI	EC		MCB 519 SI	EC			
Overland		600		11-		*	MCB 760 SI			MCB 523 SI				
Two Hundred		200		06-		*	MCB 519 SI	EC		MCB 519 SI	EC			
ARCTIC CAT		, Cruiser, H2 Cruiser, GT	700		09-		*	MCB 773 SI			MCB 773 SI			
		, H1	400		09-		*	MCB 773 SI			MCB 773 SI			
		, i	450		11-		*	MCB 773 SI			MCB 773 SI			
		2x4 (2T) Youth	90		02-04						MCS 843			
	2x4 (4T) Youth	90		04-05						MCS 843				
	2x4/4x4	250		05-		*	MCB 773 SI			MCB 773 SI				
	2x4/4x4	250		99-04		*	MCB 763 SI			MCB 763 SI				
	2x4/4x4	300		98-04		*	MCB 763 SI			MCB 763 SI				
	2x4/4x4	400		05-		*	MCB 773 SI			MCB 773 SI				
	2x4/4x4	400		98-04		*	MCB 763 SI			MCB 763 SI				
	2x4/4x4	500		05-		*	MCB 773 SI			MCB 773 SI				
	2x4/4x4	500		98-04		*	MCB 763 SI			MCB 763 SI				
	4x4	300		05-		*	MCB 773 SI			MCB 773 SI				
	4x4	500		02-04		*	MCB 763 SI			MCB 763 SI				
	4x4	500		03-04		*	MCB 763 SI			MCB 763 SI				
4x4	500		05-		*	MCB 773 SI			MCB 773 SI					

MARCA	MODELLO	CC	TELAIO	ANNO	NOTE	DOPPO DISCO	PASTIGLIE ANT	TIPO 1	TIPO 2	PASTIGLIE POST	TIPO '1	TIPO '2	NOTE'
MAKE	MODEL	CC	VIN	YEARS	NOTE	DOUBLE DISC	FRONT PAD	TYPE 1	TYPE 2	REAR PAD	TYPE '1	TYPE '2	NOTE'
ARCTIC CAT	4x4	500		05-		*	MCB 773 SI			MCB 773 SI			
	ATV	300		10-		*	MCB 773 SI			MCB 773 SI			
	ATV	350		12-		*	MCB 773 SI			MCB 773 SI			
	Cruiser, H2 EFI Cruiser	1000		09-		*	MCB 773 SI			MCB 773 SI			
	Diesel Utility, Super Duty D.	700		07-		*	MCB 773 SI			MCB 773 SI			
	DVX	250		06-09		*	MCB 760 SI			MCB 732 SI			
	DVX	300		09-		*	MCB 760 SI			MCB 732 SI			
	DVX	400		04-08		*	MCB 561 SI			MCB 626 SI			
	Efi 4x4	700		06-		*	MCB 773 SI			MCB 773 SI			
	EFI, EFI LE, Cruiser, C.i	550		09-		*	MCB 773 SI			MCB 773 SI			
	FIS	400		05-		*	MCB 773 SI			MCB 773 SI			
	FIS	400		98-04		*	MCB 763 SI			MCB 763 SI			
	GT, GT S	550		10-		*	MCB 773 SI			MCB 773 SI			
	H1 EFI, i, iGT	450		10-		*	MCB 773 SI			MCB 773 SI			
	H1, V2 4x4	650		05-		*	MCB 773 SI			MCB 773 SI			
	H2 EFI, 4x4	1000		08-		*	MCB 773 SI			MCB 773 SI			
	i	450		11-		*	MCB 773 SI			MCB 773 SI			
	i, i GT, i LTD	550		11-		*	MCB 773 SI			MCB 773 SI			
	LTD	700		11-		*	MCB 773 SI			MCB 773 SI			
	Mudpro, i Mudpro	700		09-		*	MCB 773 SI			MCB 773 SI			
	Mudpro, i Mudpro	1000		10-		*	MCB 773 SI			MCB 773 SI			
	Prowler	550		09-		*	MCB 773 SI			MCB 773 SI			
	Prowler	650		06-		*	MCB 773 SI			MCB 773 SI			
	Prowler	700		08-		*	MCB 773 SI			MCB 773 SI			
	Prowler	1000		09-		*	MCB 773 SI			MCB 773 SI			
	S, S LTD	550		10-		*	MCB 773 SI			MCB 773 SI			
	S, S LTD	700		10-		*	MCB 773 SI			MCB 773 SI			
	Thundercat H2	1000		08-10		*	MCB 773 SI			MCB 773 SI			
	Wildcat Sport	700		15-		*	MCB 890 SI			MCB 773 SI			
	Wildcat X	1000		16-		*	MCB 889 SI			MCB 773 SI			
	Y12 Youths	90		02-05		*	MCS 843						
	Y6 Youths 2x4	50		04-05		*	MCS 843						
	BAROSSA	Bronco	300	SMC			*	MCB 523 SI			MCB 523 SI		
Cheetah		170		03-06			MCS 962			MCB 519 SI			
Cheetah		250		03-06			MCS 962			MCB 519 SI			
Stinger		170		06-			MCS 962			MCB 582 SI			
BOMBARDIER		50		02-04			MCS 832			MCS 819			
		90		02-04			MCS 832			MCS 819			
		250		06-	links/left		MCB 724 SI						rechts
		250		06-	rechts/right		MCB 723 SI			MCB 724 SI			links
		650	A	01-06	links/left		MCB 724 SI						rechts
		650	A	01-06	rechts/right		MCB 723 SI			MCB 724 SI			links
	Outlander	330		03-	links/left		MCB 724 SI						rechts
	Outlander	330		03-	rechts/right		MCB 723 SI			MCB 724 SI			links
	Outlander	400		03-06	links/left		MCB 724 SI						rechts
	Outlander	400		03-06	rechts/right		MCB 723 SI			MCB 724 SI			links
Outlander	800		06-	links/left		MCB 724 SI						rechts	
Outlander	800		06-	rechts/right		MCB 723 SI			MCB 724 SI			links	

PASTIGLIE FRENO TRW ATV - UTV

MARCA	MODELLO	CC	TELAIO	ANNO	NOTE	DOPPO DISCO	PASTIGLIE ANT	TIPO 1	TIPO 2	PASTIGLIE POST	TIPO '1	TIPO'2	NOTE'	
MAKE	MODEL	CC	VIN	YEARS	NOTE	DOUBLE DISC	FRONT PAD	TYPE 1	TYPE 2	REAR PAD	TYPE '1	TYPE '2	NOTE'	
BOMBARDIER	Quest	50		03-04			MCS 832			MCS 819				
	Quest	90		03-04			MCS 832			MCS 819				
	Quest	500		02-	links/left		MCB 724 SI						rechts	
	Quest	500		02-	rechts/right		MCB 723 SI			MCB 724 SI			links	
	Quest	650		02-	links/left		MCB 724 SI						rechts	
	Quest	650		02-	rechts/right		MCB 723 SI			MCB 724 SI			links	
	Quest Max	650			links/left		MCB 724 SI						rechts	
	Quest Max	650			rechts/right		MCB 723 SI			MCB 724 SI			links	
	Rally 2x4	200		03-		*	MCB 519 SI							
	Traxter	500		01-06	links/left		MCB 724 SI						links	
	Traxter	500		01-06	rechts/right		MCB 723 SI			MCB 724 SI				
	Traxter	500	Traxter	99-00		*	MCB 700			MCB 700			rechts	
	Traxter Max	500		01-06	links/left		MCB 724 SI						rechts	
	Traxter Max	500		01-06	rechts/right		MCB 723 SI			MCB 724 SI			links	
	Traxter Max	650		03-05	links/left		MCB 724 SI						rechts	
	Traxter Max	650		03-05	rechts/right		MCB 723 SI			MCB 724 SI			links	
	CAN-AM	Commander	800		11-	links/left		MCB 615 SI			MCB 582 SI			
		Commander	800		11-	rechts/right		MCB 582SI						
		Commander	1000		11-	links/left		MCB 615 SI			MCB 582 SI			
		Commander	1000		11-	rechts/right		MCB 582 SI						
Commander MAX		1000		14-	links/left		MCB 615 SI			MCB 724 SI				
Commander MAX		1000		14-	rechts/right		MCB 582 SI			MCB 723 SI				
Maverick		1000		13-	links/left		MCB 615 SI			MCB 724 SI				
Maverick		1000		13-	rechts/right		MCB 582 SI			MCB 723 SI				
Outlander Max R		800		07-	links/left		MCB 724 SI			MCB 724 SI			rechts/right	
Outlander Max R		800		07-	rechts/right		MCB 723 SI						links/left	
Outlander R, R Max		800		12-	links/left		MCB 862 SI						rechts/right	
Outlander R, R Max		800		12-	rechts/right		MCB 861 SI			MCB 861 SI			links/left	
Outlander, EFI, Max		400		07-	links/left		MCB 724 SI			MCB 724 SI			rechts/right	
Outlander, EFI, Max		400		07-	rechts/right		MCB 723 SI						links/left	
Outlander, Max		500		07-	links/left		MCB 724 SI			MCB 724 SI			rechts/right	
Outlander, Max		500		07-	rechts/right		MCB 723 SI						links/left	
Outlander, Max		570		16-	links/left		MCB 862 SI							
Outlander, Max		570		16-	rechts/right		MCB 861 SI			MCB 861 SI				
Outlander, Max		650		07-	links/left		MCB 724 SI			MCB 724 SI			rechts/right	
Outlander, Max		650		07-	rechts/right		MCB 723 SI						links/left	
Outlander, Outlander Max		450		15-	links/left		MCB 862 SI							
Outlander, Outlander Max		450		15-	rechts/right		MCB 861 SI			MCB 861 SI				
Outlander, Outlander Max		500		07-12	links/left		MCB 724 SI			MCB 724 SI			rechts/right	
Outlander, Outlander Max		500		07-12	rechts/right		MCB 723 SI						links/left	
Outlander, Outlander Max		500		13-	links/left		MCB 862 SI						rechts/right	
Outlander, Outlander Max		500		13-	rechts/right		MCB 861 SI			MCB 861 SI			links/left	
Outlander, Outlander Max		650		13-	links/left		MCB 862 SI						rechts/right	
Outlander, Outlander Max		650		13-	rechts/right		MCB 861 SI			MCB 861 SI			links/left	
Outlander, Outlander Max		1000		13-	links/left		MCB 862 SI						rechts/right	
Outlander, Outlander Max		1000		13-	rechts/right		MCB 861 SI			MCB 861 SI			links/left	
Outlander, R, R EFI, R XT	800		07-	links/left		MCB 724 SI			MCB 724 SI			rechts/right		
Outlander, R, R EFI, R XT	800		07-	rechts/right		MCB 723 SI						links/left		

MARCA	MODELLO	CC	TELAIO	ANNO	NOTE	DOPPO DISCO	PASTIGLIE ANT	TIPO 1	TIPO 2	PASTIGLIE POST	TIPO '1	TIPO '2	NOTE'	
MAKE	MODEL	CC	VIN	YEARS	NOTE	DOUBLE DISC	FRONT PAD	TYPE 1	TYPE 2	REAR PAD	TYPE '1	TYPE '2	NOTE'	
CAN-AM	Renegade	500		07-	links/left		MCB 724 SI			MCB 724 SI			rechts/right	
	Renegade	500		07-	rechts/right		MCB 723 SI						links/left	
	Renegade	500		12-	links/left		MCB 862 SI						rechts/right	
	Renegade	500		12-	rechts/right		MCB 861 SI			MCB 861 SI			links/left	
	Renegade	570		16-	links/left		MCB 862 SI							
	Renegade	570		16-	rechts/right		MCB 861 SI			MCB 861 SI				
	Renegade	800		12-13	links/left		MCB 862 SI						rechts/right	
	Renegade	800		12-13	rechts/right		MCB 861 SI			MCB 861 SI			links/left	
	Renegade	800		08-11	links/left		MCB 724 SI			MCB 724 SI			rechts/right	
	Renegade	800		08-11	rechts/right		MCB 723 SI						links/left	
	Renegade	800		14-	links/left		MCB 862 SI			MCB 862 SI			rechts/right	
	Renegade	800		14-	rechts/right		MCB 861 SI			MCB 861 SI			links/left	
	Renegade	1000		12-13	links/left		MCB 862 SI			MCB 862 SI			rechts/right	
	Renegade	1000		12-13	rechts/right		MCB 861 SI			MCB 861 SI			links/left	
	Renegade	1000		14-	links/left		MCB 862 SI			MCB 862 SI			rechts/right	
	Renegade	1000		14-	rechts/right		MCB 861 SI			MCB 861 SI			links/left	
	X	90		10-13			*	MCB 519	SI	EC	MCB 519	SI	EC	
	X	650		07	links/left			MCB 724 SI			MCB 861 SI			rechts/right
	X	650		07	rechts/right			MCB 723 SI						links/left
	X3 Max Turbo, Max Turbo R	900		18-	links/left			MCB 862 SI			MCB 862 SI			
	X3 Max Turbo, Max Turbo R	900		18-	rechts/right			MCB 861 SI			MCB 861 SI			
	X3 Turbo, Turbo R	900		18-	links/left			MCB 862 SI			MCB 862 SI			
	X3 Turbo, Turbo R	900		18-	rechts/right			MCB 861 SI			MCB 861 SI			
	X3, X3 Max	900		17-	links/left			MCB 862 SI			MCB 862 SI			
	X3, X3 Max	900		17-	rechts/right			MCB 861 SI			MCB 861 SI			
		70		08-12							MCS 843			
		90		10-							MCS 843			
		250		08-				MCB 760 SI			MCB 760 SI			
	450		08-12	VA: don't use shim			MCB 859 SI			MCB 860 SI				
CECTEK	EFI Estoc	500		09-			MCB 836 SI			MCB 519 SI				
	EFI Gladiator	500		09-			MCB 760 SI			MCB 519 SI				
	EFI Gladiator	525		12-			MCB 760 SI			MCB 519 SI				
	EFI King Cobra	500		09-			MCB 836 SI			MCB 519 SI				
	EFI Quadrift	500		09-			MCB 836 SI			MCB 519 SI				
	EFI Quadrift	525		12-			MCB 836 SI			MCB 519 SI				
CF MOTO	C-Force L, G-Force L	450		16-			MCB 863 SI			MCB 756 SI				
	Terralander	500		11-	Parkingbrake					MCB 668 SI				
	Terralander	500		11-			MCB 863 SI			MCB 756 SI				
	Terralander	625		11-	Parkingbrake					MCB 668 SI				
	Terralander	625		11-			MCB 863 SI			MCB 756 SI				
	Terralander	800		12-			MCB 863 SI			MCB 756 SI				
	U-Force	550		15-	links/left		MCB 615 SI							
	U-Force	550		15-	rechts/right		MCB 582 SI							
	Z-Force, EX	550		15-	links/left		MCB 615 SI							
	Z-Force, EX	550		15-	rechts/right		MCB 582 SI							
CPI	Z-Force, EX	800		15-	links/left		MCB 615 SI							
	Z-Force, EX	800		15-	rechts/right		MCB 582 SI							
	ATV	250		06-07			MCB 760 SI			MCB 615 SI				

PASTIGLIE FRENO TRW ATV - UTV

MARCA	MODELLO	CC	TELAIO	ANNO	NOTE	DOPPO DISCO	PASTIGLIE ANT	TIPO 1	TIPO 2	PASTIGLIE POST	TIPO '1	TIPO'2	NOTE'
MAKE	MODEL	CC	VIN	YEARS	NOTE	DOUBLE DISC	FRONT PAD	TYPE 1	TYPE 2	REAR PAD	TYPE '1	TYPE '2	NOTE'
CPI	Crab	50		03-						MCB 615 SI			
	Crab	100		03-						MCB 615 SI			
	Power Quad	250		07-		*	MCB 519 SI	EC		MCB 805 SI			
	Quad	50		06-						MCB 615 SI			
DAELIM	Quad	250		05-09		*	MCB 519 SI	EC		MCB 604			
	Quad	300		07-12		*	MCB 519 SI	EC		MCB 800			
DERBI	Sector Quad	250		05-06		*	MCB 519 SI	EC		MCB 800	SI		
		50		04-07			MCS 832			MCS 805			
		200		04-05			MCS 962			MCB 523 SI			
		200		04-07		*	MCB 519 SI	EC		MCB 523 SI			
E-TON		250		04-05			MCS 962			MCB 523 SI			
		250		04-07		*	MCB 519 SI	EC		MCB 523 SI			
	Eukon	150		05-07			MCS 838			MCB 615 SI			
	Ranger	90		03-04						MCS 819			
	Sierra	90		99-03			MCS 838			MCS 819			
	Vector, ST Vector	250		06-		*	MCB 519	SI	EC	MCB 800	SI		
	Vector, ST Vector	300		06-		*	MCB 519	SI	EC	MCB 800	SI		
	Viper	40		03-04						MCS 819			
	Viper R	150		05-		*	MCS 800			MCB 615 SI			
	Viper ST	150		05-		*	MCB 519	SI	EC	MCS 819			
FACTORY	Vortex, ST Vortex	300		06-		*	MCB 519	SI	EC	MCB 800	SI		
	Yukon	150		00-03		*	MCS 800			MCB 615 SI			
	Yukon ST	150		05-		*	MCB 519	SI	EC	MCS 819			
	Helix	50		04-						MCB 519	SI	EC	
	Helix	100		04-						MCB 519	SI	EC	
	Rex	50		04-						MCB 519	SI	EC	
GAS GAS	Rex	100		04-						MCB 519	SI	EC	
	Wild HP	50		04-		*	MCB 648 SI	RSI	EC	MCB 648 SI	RSI	EC	
	Wild HP	240		04-		*	MCB 648 SI	RSI	EC	MCB 648 SI	RSI	EC	
	Wild HP	300		03-		*	MCB 648 SI	RSI	EC	MCB 648 SI	RSI	EC	
GILERA	Wild HP	450		03-		*	MCB 648 SI	RSI	EC	MCB 648 SI	RSI	EC	
	Oregon Quad	250		07-		*	MCB 539 SI			MCB 732 SI			
GOES	Max	360		08-		*	MCB 863 SI						
	Max	520		07-		*	MCB 863 SI			MCB 756 SI			
		520		07-		*	MCB 863 SI			MCB 756 SI			
		525		12-		*	MCB 863 SI			MCB 756 SI			
		620		11-		*	MCB 863 SI			MCB 756 SI			
HERCULES		625		12-		*	MCB 863 SI			MCB 756 SI			
	ATV	280		07-		*	MCB 760 SI						
HONDA	ATV Sport	300		07-		*	MCB 760 SI						
	EX Sporttrax	250		01-08		*	MCB 561SI			MCS 821			
	EX Sporttrax	300	TE19	93-08		*	MCB 561 SI			MCB 561 SI			
	EX Sporttrax	400	TE23	99-		*	MCB 561 SI	EC		MCB 561 SI	EC		
	FA, Fourtrax	400		04-07			MCS 837			MCS 995			
	FA6, FGA6 Rincon	680		06-		*	MCB 823 SI			MCB 769 SI			
	FGA, Fourtrax Rancher	400		04-07			MCS 837			MCS 995			
	FM, FE	450		02-04			MCS 837						
	Fourtrax	70		86-87			MCS 837						

MARCA	MODELLO	CC	TELAIO	ANNO	NOTE	DOPPO DISCO	PASTIGLIE ANT	TIPO 1	TIPO 2	PASTIGLIE POST	TIPO '1	TIPO '2	NOTE'
MAKE	MODEL	CC	VIN	YEARS	NOTE	DOUBLE DISC	FRONT PAD	TYPE 1	TYPE 2	REAR PAD	TYPE '1	TYPE '2	NOTE'
HONDA	Fourtrax	200		90-93		*	MCS 836						
	Fourtrax	500		01-04			MCS 837			MCS 822			
	Fourtrax	680		06-		*	MCB 823 SI			MCB 769 SI			
	Fourtrax	700		08-			MCB 669 SI			MCB 823 SI			
	Fourtrax	500		05-		*	MCB 823 SI			MCS 806			
	Fourtrax Rancher AT	420		09-		*	MCB 561 SI			MCB 769 SI			
	FW	300		88-00		*	MCS 837			MCS 802			
	FW	400		95-00			MCS 837			MCS 995			
	G-N	350		86-93			MCS 823			MCS 823			
	M	125		84-85	AU market		MCS 800						
	R	250	ATC250	81		*	MCB 510 SI						
	R	250	ATC250	82-84		*	MCB 554 SI			MCB 538 SI			
	R	250	ATC250	85-86		*	MCB 534 SI			MCB 534 SI			
	R, ER	450	TE22	04-		*	MCB 669	SI	EC	MCB 769 SI			
	Rincon	650		03-			MCS 837			MCB 769 SI			
	S, ES	450		98-02			MCS 837						
	Sporttrax	250		01-		*	MCB 561 SI		EC				
	Sporttrax	450		01-		*	MCB 561 SI	EC		MCB 561 SI	EC		
	SX	200		86-87		*	MCS 836						
	V/W/X/Y	250	TRX250	97-12	AU market	*	MCS 836			MCS 821			
X	350		85		*	MCB 534 SI			MCB 538 SI				
X	350		86-		*	MCB 574 SI			MCB 538 SI				
		300		88-00		*	MCS 836						
HYOSUNG		400		05-06		*	MCB 510 SI						
	S Sport	450		07-10		*	MCB 510 SI			MCB 626 SI			
JOHN DEERE		855		11-		*	MCB 889 SI						
	D Gator	350		10-	don't use shim	*	MCB 860 SI			MCB 860 SI			
	Gator	625		11-		*	MCB 889 SI						
	Gator	825		11-		*	MCB 889 SI						
KAWASAKI		400	KFX 400	03-		*	MCB 554 SI			MCB 626 SI			
		450	SF450B	07-	links/left		MCB 757 SI						
	A, B, 4WD	300		99-04			MCB 510 SI			MCS 892			
	B	300		95-		*	MCB 560 SI			MCB 561 SI			
	Bayou	220		88-01			MCS 839			MCS 853			
	Bayou	250		03-11			MCS 839			MCS 853			
	Bayou	300		88		*	MCB 523 SI			MCS 853			
	Bayou	300		89-	links/left		MCB 582 SI	SV		MCS 892			
	Bayou	300		89-	rechts/right		MCB 615 SI						
	Bayou	400		93-99	links/left		MCB 582 SI			MCS 892			
	Bayou	400		93-99	rechts/right		MCB 615 SI						
	Brute Force	750	KVF750	05-	rechts/right		MCB 615 SI						
	Brute Force	300		13-		*	MCB 510 SI			MCB 760 SI			links/left
	Brute Force	750	KVF750	05-	links/left		MCB 582 SI						
	Brute Force 4x4i	650		05-	links/left		MCB 582 SI						
	Brute Force 4x4i	650		05-	rechts/right		MCB 615 SI						
	KSF	50	LM4AA	03-05			MCS 838			MCS 901			
	KSF	50	WA04A	07-						MCB 712			
	KSF	90	WE07A	07-						MCB 712			

PASTIGLIE FRENO TRW ATV - UTV

MARCA	MODELLO	CC	TELAIO	ANNO	NOTE	DOPPO DISCO	PASTIGLIE ANT	TIPO 1	TIPO 2	PASTIGLIE POST	TIPO '1	TIPO'2	NOTE'	
MAKE	MODEL	CC	VIN	YEARS	NOTE	DOUBLE DISC	FRONT PAD	TYPE 1	TYPE 2	REAR PAD	TYPE '1	TYPE '2	NOTE'	
KAWASAKI	KSV	700	SV700A	04-	links/left		MCB 757 SI							
	KSV	700	SV700A	04-	rechts/right		MCB 758 SI							
	Mule Pro	800		15-17	rechts/right		MCB 615 SI							
	Prairie	400	VF400A	97-98		*	MCB 510 SI			MCS 892			links/left	
	Prairie	650	KV650	01-03	links/left		MCB 757 SI							
	Prairie	650		01-03	rechts/right		MCB 758 SI							
	Prairie	700	KVF700	04-06	links/left		MCB 757 SI						links/left	
	Prairie	700	KVF700	04-06	rechts/right		MCB 758 SI							rechts/right
	Prairie 2x4	400	VF400D	98-01		*	MCB 510 SI			MCS 892				rechts/right
	Prairie 4x4	400	VF400C	98-01		*	MCB 510 SI			MCS 892				
	Teryx	800		14-17	links/left		MCB 582 SI							
	Teryx	800		14-17	links/left		MCB 582 SI							
	Teryx	800		14-17	rechts/right		MCB 615 SI							
	Teryx	800		14-17	rechts/right		MCB 615 SI							
	V-Force	700	SV700A	04-	links/left		MCB 757 SI							
	V-Force	700	SV700A	04-	rechts/right		MCB 758 SI							
			80		03-06			MCS 838						
			200		81-84			MCS 854			MCS 839			
			200		88-97			MCS 839						
			360		03-11			MCB 510 SI						
			400	KFX400	03-04		*	MCB 554 SI			MCB 626 SI			
			400	AK47B	05-		*	MCB 554 SI			MCB 626 SI			
			450	SF450B	07-	rechts/right		MCB 758 SI			MCB 561SI			
			750		08-	links/left		MCB 582 SI						
			750		08-	rechts/right		MCB 615 SI						
	KEEWAY	Dragon Quad	250		07-09		*	MCB 519 SI			MCB 510 SI			
KREIDLER	Mustang	170		06-			MCS 962			MCB 582 SI				
KTM	ATV	450		08-09			MCB 824 SI			MCB 825 SI				
	ATV	450		08-10			MCB 824 SI			MCB 825 SI				
	ATV	505		08-			MCB 824 SI			MCB 825 SI				
	ATV	505		08-			MCB 824 SI			MCB 825 SI				
	ATV	525		08-			MCB 824 SI			MCB 825 SI				
	Racing	525		06-07			MCB 648 SI	RSI	EC	MCB 743 SI	RSI	EC		
KYMCO	Easy	50		01-			MCB 665	EC		MCS 800				
	Grumbler i.	450		13-16		*	MCB 773 SI			MCB 773 SI				
	i Turf	700	U11	14-	Parkingbrake					MCB 760 SI				
	i Turf	700	U11	14-		*	MCB 891 SI			MCB 891 SI				
	Maxxer	250	L30	09-		*	MCB 760 SI			MCB 760 SI			links/left	
	Maxxer	300	L30	06-17	Parkingbrake					MCB 832 P			Parkbremse	
	Maxxer	300	L30	06-17		*	MCB 760 SI			MCB 732 SI				
	Maxxer	400		08-10	Parkingbrake					MCB 875 P			Parkbremse	
	Maxxer	400		08-10		*	MCB 773 SI			MCB 773 SI				
	Maxxer i	450	A40	09-	Parkingbrake					MCB 875 P			Parkbremse	
	Maxxer i	450	A40	09-		*	MCB 773 SI			MCB 773 SI				
	Maxxer Supermoto	300	L30	15-		*	MCB 760 SI			MCB 732 SI			links/left	
	Mongoose Quad	250	L30	04-07		*	MCB 760 SI			MCB 732 SI				
	Mxer	125	L1	03-07				MCS 800			MCB 712			
	Mxer	150	L1	03-07				MCS 800			MCB 712			

MARCA	MODELLO	CC	TELAIO	ANNO	NOTE	DOPPO DISCO	PASTIGLIE ANT	TIPO 1	TIPO 2	PASTIGLIE POST	TIPO '1	TIPO '2	NOTE'
MAKE	MODEL	CC	VIN	YEARS	NOTE	DOUBLE DISC	FRONT PAD	TYPE 1	TYPE 2	REAR PAD	TYPE '1	TYPE '2	NOTE'
KYMCO	MXU	150	L8	07-17			MCS 800			MCB 712			
	MXU	250	L60	04-		*	MCB 760 SI			MCB 732 SI			
	MXU	300	L60	06-10		*	MCB 760 SI			MCB 760 SI			
	MXU	400	A40	08-	Parkingbrake					MCB 875 P			Parkbremse
	MXU	400	A40	08-		*	MCB 760 SI			MCB 760 SI			
	MXU	500		05-		*	MCB 760 SI			MCB 760 SI			
	MXU i	450	A40	11-	Parkingbrake					MCB 875 P			Parkbremse
	MXU i	450	A40	11-		*	MCB 760 SI			MCB 760 SI			
	MXU i.	500		09-14	Parkbremse					MCB 760 SI			
	MXU i.	500		09-14		*	MCB 891 SI			MCB 891 SI			
	MXU i.	550	Z21	12-	Parkingbrake					MCB 760 SI			
	MXU i.	550	Z21	12-		*	MCB 891 SI			MCB 891 SI			
	MXU i.	700	Z22	13-	Parkingbrake					MCB 760 SI			
	MXU i.	700	Z22	13-		*	MCB 891 SI			MCB 891 SI			
	MXU R	250	L61	11-13		*	MCB 760 SI			MCB 760 SI			
	MXU R	300	A60	10-		*	MCB 760 SI			MCB 760 SI			
	LAVERDA	Urban Quad	250		06			MCB 769 SI			MCB 769 SI		
		450	Y10	15-		*	MCB 760 SI			MCB 760 SI			
		500	U10	08-15		*	MCB 760 SI			MCB 760 SI			
Phoenix		125		01-04						MCB 712			
Phoenix		150		01-04						MCB 712			
Phoenix		250		01-04						MCB 712			
Quasar		50		04-			MCS 832			MCS 805			
Quasar		100		04-			MCS 832			MCS 805			
Quasar		125		04-						MCB 763 SI			
Quasar		180		04-						MCB 763 SI			
MASSEY FERGUSON	Quasar 4x4	400		04-		*	MCB 763 SI			MCB 763 SI			
	Quasar 4x4	500		04-		*	MCB 763 SI			MCB 763 SI			
	2WD/4WD	250		04		*	MCB 763 SI			MCB 763 SI			
	2WD/4WD	300		04		*	MCB 763 SI			MCB 763 SI			
	4WD	400		04		*	MCB 763 SI			MCB 763 SI			
	4WD Auto	400		04		*	MCB 763 SI			MCB 763 SI			
	4WD Auto	500		05-09		*	MCB 773 SI			MCB 773 SI			
	4WD Auto	500		05-09		*	MCB 773 SI			MCB 773 SI			
	4WD Auto	650		05-09		*	MCB 773 SI			MCB 773 SI			
	4WD Auto Diesel	700		05-09		*	MCB 773 SI			MCB 773 SI			
PGO	4WD TBX Auto	500		04		*	MCB 763 SI			MCB 763 SI			
	Bug	500		08-	Parkingbrake					MCB 668 SI			
	Bug	500		08-			MCB 836 SI			MCB 760 SI			Parkbremse
	Bugrider	50		06-			MCB 807			MCB 510			
	Bugrider	150		05-		*	MCB 807			MCB 510			
	Bugrider	200		07-		*	MCB 807			MCB 805 SI			
	Bugrider	250		05-		*	MCB 807			MCB 805 SI			
	Bugxter	150		05-		*	MCB 807			MCB 510			
	Racer	500		07-			MCB 836 SI			MCB 760 SI			
	X-Rider	50		03-						MCB 519 SI	EC		
	X-Rider	125		03-						MCB 519 SI	EC		
	X-Rider	150		03-						MCB 519 SI	EC		

PASTIGLIE FRENO TRW ATV - UTV

MARCA	MODELLO	CC	TELAIO	ANNO	NOTE	DOPPO DISCO	PASTIGLIE ANT	TIPO 1	TIPO 2	PASTIGLIE POST	TIPO '1	TIPO'2	NOTE'
MAKE	MODEL	CC	VIN	YEARS	NOTE	DOUBLE DISC	FRONT PAD	TYPE 1	TYPE 2	REAR PAD	TYPE '1	TYPE '2	NOTE'
POLARIS		500		04-		*	MCB 761 SI			MCB 761 SI			
	ATP	330		04-		*	MCB 761 SI			MCB 761 SI			
	Forest	850		15-		*	MCB 855 SI			MCB 855 SI			
	Forest	1000		15-		*	MCB 855 SI			MCB 855 SI			
	General EPS	1000		16-		*	MCB 853 SI			MCB 854 SI			
	Hawkeye	300		07-09		*	MCB 761 SI			MCB 761 SI			
	Magnum 2x4,4x4	325		00-02		*	MCB 761 SI			MCB 762 SI			
	Magnum 2x4,4x4	330		03-		*	MCB 761 SI						
	Magnum 2x4,4x4 HDS	500		02-		*	MCB 761 SI			MCB 798 SI			
	Magnum 4x4	500		00-01		*	MCB 761 SI			MCB 762 SI			
	MVRS 4x4	700		08-		*	MCB 853 SI			MCB 853 SI			
	Outlaw	50		08-			MCS 832			MCS 843			
	Outlaw	90		43411						MCS 843			
	Outlaw	500		06-07		*	MCB 761 SI			MCB 761 SI			
	Outlaw S, IRS	525		07-		*	MCB 854 SI			MCB 761 SI			
	Outlaw S, MXR	450		08-		*	MCB 854 SI			MCB 619			
	Phoenix	200		10-		*	MCB 868 SI			MCB 523 SI			
	Predator	50		04-			MCS 832			MCS 843			
	Predator	90		03-04			MCS 832			MCS 843			
	Predator	500		03-07		*	MCB 761 SI			MCB 761 SI			
	Ranger 2x4/4x4	500		06-07		*	MCB 854 SI			MCB 854 SI			
	Ranger 2x4/4x4 EFI	500		08-10		*	MCB 853 SI			MCB 854 SI			
	Ranger 4x4 EFI	500		11-		*	MCB 854 SI			MCB 854 SI			
	Ranger 4x4 EFI	700		07		*	MCB 857 SI			MCB 857 SI			
	Ranger 4x4 EFI	700		08-		*	MCB 853 SI			MCB 857 SI			
	Ranger 6x4 EFI	700		08		*	MCB 853 SI			MCB 857 SI			
	Ranger 6x6	500		04-05		*	MCB 761 SI						
	Ranger 6x6 EFI	700		06-09		*	MCB 857 SI			MCB 857 SI			
	Ranger Crew	500		11-		*	MCB 853 SI			MCB 854 SI			
	Ranger Crew	800		10-		*	MCB 853 SI			MCB 857 SI			
	Ranger Crew 4x4 EFI	700		09		*	MCB 853 SI			MCB 857 SI			
	Ranger Diesel	900		11-		*	MCB 853 SI			MCB 857 SI			
	Ranger EV, HD, XP, 6x6	800		10-11		*	MCB 853 SI			MCB 857 SI			
	Ranger HO	400		10-		*	MCB 853 SI			MCB 854 SI			
	Ranger HO 4x4 EFI	500		09-11		*	MCB 853 SI			MCB 854 SI			
	Ranger RZR	170		09-17		*	MCB 868 SI			MCB 869 SI			
	Ranger RZR EFI	570		12-		*	MCB 854 SI			MCB 619			
	Ranger RZR-4, EPS	800		10-		*	MCB 853 SI			MCB 857 SI			
	Ranger RZR, S EFI	800		08-		*	MCB 854 SI			MCB 619			
	Ranger XP 4x4	700		06-08		*	MCB 857 SI			MCB 857 SI			
Revolver	500		06-		*	MCB 619			MCB 619				
RZR XP	900		11-		*	MCB 853 SI			MCB 857 SI				
Scrambler	50		01-03			MCS 832			MCS 843				
Scrambler	90		01-03			MCS 832			MCS 843				
Scrambler 2x4	500		01-02		*	MCB 761 SI			MCB 762 SI				
Scrambler 2x4	500		07-08		*	MCB 761 SI			MCB 798 SI				
Scrambler 2x4,4x4	400		00-		*	MCB 761 SI			MCB 762 SI				
Scrambler 4x4	500		97		*	MCB 761 SI			MCB 668 SI				

MARCA	MODELLO	CC	TELAIO	ANNO	NOTE	DOPPO DISCO	PASTIGLIE ANT	TIPO 1	TIPO 2	PASTIGLIE POST	TIPO '1	TIPO '2	NOTE'	
MAKE	MODEL	CC	VIN	YEARS	NOTE	DOUBLE DISC	FRONT PAD	TYPE 1	TYPE 2	REAR PAD	TYPE '1	TYPE '2	NOTE'	
POLARIS	Scrambler 4x4	500		05-		*	MCB 761 SI			MCB 798 SI				
	Scrambler 4x4	500		98-04		*	MCB 761 SI			MCB 762 SI				
	Scrambler HO/ HO EPS	850		13-		*	MCB 855 SI			MCB 855 SI				
	Scrambler MD, XP	1000		15-		*	MCB 855 SI			MCB 855 SI				
	Sportsman	300		08-10		*	MCB 761 SI			MCB 761 SI				
	Sportsman	400		01-02		*	MCB 761 SI			MCB 762 SI				
	Sportsman	400		03-05		*	MCB 761 SI			MCB 798 SI				
	Sportsman	450		06-07		*	MCB 761 SI			MCB 798 SI				
	Sportsman 4x4	500		96-		*	MCB 761 SI			MCB 668 SI				
	Sportsman 4x4	600		03-05		*	MCB 619			MCB 798 SI				
	Sportsman 4x4	700		02-06		*	MCB 619			MCB 798 SI				
	Sportsman 6x6	500		00-08		*	MCB 761 SI							
	Sportsman 6x6 Big Boss	800		09-		*	MCB 761 SI			MCB 761 SI				
	Sportsman EFI Quad HO	500		08-		*	MCB 619			MCB 855 SI				
	Sportsman EFI, MV	700		05-07		*	MCB 761 SI			MCB 798 SI				
	Sportsman EFI/HO	800		05-08		*	MCB 619			MCB 798 SI				
	Sportsman EFI/HO	800		09-		*	MCB 619			MCB 855 SI				
	Sportsman HO 4x4	400		08-10		*	MCB 761 SI			MCB 761 SI				
	Sportsman HO 4x4	400		11-		*	MCB 761 SI			MCB 855 SI				
	Sportsman HO/EFI	500		03-08		*	MCB 619			MCB 798 SI				
	Sportsman MD, Touring, XP	1000		15-		*	MCB 855 SI			MCB 855 SI				
	Sportsman Touring EPS	850		10-		*	MCB 855 SI			MCB 855 SI				
	Sportsman Touring HO	500		09-11		*	MCB 619			MCB 855 SI				
	Sportsman Touring HO EPS	850		13-		*	MCB 855 SI			MCB 855 SI				
	Sportsman Touring, X 2 EFI	800		07-		*	MCB 761 SI			MCB 761 SI				
	Sportsman X2 EFI	500		07-09		*	MCB 761 SI			MCB 761 SI				
	Sportsman X2, XP, XP EPS	550		09-		*	MCB 855 SI			MCB 855 SI				
	Sportsman X2, XP, XP EPS	850		09-		*	MCB 855 SI			MCB 855 SI				
	Sportsman XP	500		09		*	MCB 855 SI			MCB 855 SI				
	Sportsman, EPS, Touring EPS	550		10-		*	MCB 855 SI			MCB 855 SI				
	Sportsmann	90		01-15				MCS 832			MCS 843			
	Trail Blazer	250		94-98			*	MCB 761 SI			MCB 668 SI			
	Trail Blazer	250		99-			*	MCB 761 SI			MCB 762 SI			
	Trail Boss	250		88-90			*	MCB 619			MCB 620			
	Trail Boss	250		91-99			*	MCB 761 SI			MCB 668 SI			
	Trail Boss	325		00-			*	MCB 761 SI			MCB 762 SI			
	Trail Boss, Trail Blazer	330		03-			*	MCB 761 SI			MCB 762 SI			
	X 2	700		08			*	MCB 761 SI			MCB 761 SI			
	Xpedition 4x4	400		00-			*	MCB 761 SI			MCB 762 SI			
	Xplorer L 4x4	400		00-			*	MCB 761 SI			MCB 762 SI			
QUADZILLA		50		06-			MCS 838			MCS 838				
		70		06-			MCS 838			MCS 838				
		110		06-			MCB 590	EC						
		125		06-			MCB 590	EC						
	4WD	600	links/left	10-			MCB 582 SI							
	4WD	600	rechts/right	10-			MCB 615 SI							
	4x4	500		06-						MCB 762 SI				
	Buggie	300		07-		*	MCB 807			MCB 805 SI				

PASTIGLIE FRENO TRW ATV - UTV

MARCA	MODELLO	CC	TELAIO	ANNO	NOTE	DOPPO DISCO	PASTIGLIE ANT	TIPO 1	TIPO 2	PASTIGLIE POST	TIPO '1	TIPO'2	NOTE'	
MAKE	MODEL	CC	VIN	YEARS	NOTE	DOUBLE DISC	FRONT PAD	TYPE 1	TYPE 2	REAR PAD	TYPE '1	TYPE '2	NOTE'	
QUADZILLA	Buggie	500		08-		*	MCB 617			MCB 617				
	E	100		06-			MCS 962			MCB 523 SI				
	E	250		06-		*	MCB 807			MCB 805 SI				
	E	500		10-		*	MCB 523 SI			MCB 523 SI				
	e 4x4	500		07-						MCB 756 SI				
	E Bugrider	200		07-		*	MCB 807			MCB 805 SI				
	E Stinger	170		06-			MCS 962			MCB 582 SI				
	E Stinger	250		06-		*	MCB 519 SI	EC		MCB 523 SI				
	E, LE	300		07-		*	MCB 523 SI			MCB 523 SI				
	Sport	450		08-		*	MCB 523 SI			MCB 523 SI				
	XLC Stinger	300		09-		*	MCB 523 SI			MCB 523 SI				
		50		03-06				MCS 838			MCS 968			
		100		06-09				MCS 838			MCS 968			
		140		06-				MCB 844			MCB 846			
	800	links/left	10-				MCB 582 SI							
	800	rechts/right	10-				MCB 615 SI							
REX	Quad	150	SMC	10-						MCB 582 SI				
	Quad	250	SMC	10-						MCB 582 SI				
SUZUKI		160		91-01			MCS 921			MCS 902				
	ATV MINI	50		02-05			MCS 838			MCS 901				
	ATV MINI	50		86-02						MCS 840				
	F	250		99-02						MCS 842				
	F King Quad	300		02	links/left		MCB 582 SI			MCS 905			links/left	
	F King Quad	300		02	rechts/right		MCB 615 SI			MCS 905			rechts/right	
	F King Quad	300		99-01						MCS 905				
	F Quadmaster	500	AM42A	00-01	links/left		MCB 582 SI			MCS 905			links/left	
	F Quadmaster	500	AM42A	00-01	rechts/right		MCB 615 SI						rechts/right	
	F Quadrunner	500		03-04		*	MCB 510 SI			MCB 723 SI				
	F Quadrunner	500	AM41A	98-02	links/left		MCB 582 SI			MCS 905			links/left	
	F Quadrunner	500	AM41A	98-02	rechts/right		MCB 615 SI						rechts/right	
	FK2 Vinson 4WD	500	AM43A	02-07		*	MCB 510 SI			MCB 523 SI				
	K2 Eiger	400	AK	02-		*	MCB 510 SI							
	K2 Eiger	400	AK	02-		*	MCB 510 SI			MCS 907				
	K2 Eiger 4WD	400	AK	02-		*	MCB 510 SI			MCS 907				
	King Quad	400		08-10	links/left		MCB 788 SI			MCS 959			rechts/right	
	King Quad	400		08-10	rechts/right		MCB 787 SI			MCS 959			links/left	
	King Quad	400		08-12	links/left		MCB 788 SI			MCS 959			rechts/right	
	King Quad	400		08-12	rechts/right		MCB 787 SI			MCS 959			links/left	
	King Quad	500	AM45P	11-16	links/left		MCB 787 SI						links/left	
	King Quad	500	AM45P	11-16	rechts/right		MCB 788 SI						rechts/right	
	King Quad	700		05-07	links/left		MCB 787 SI						links/left	
	King Quad	700		05-07	rechts/right		MCB 788 SI						rechts/right	
	King Quad X	750	AR41A	08-16	links/left		MCB 787 SI						links/left	
	King Quad X	750	AR41A	08-16	rechts/right		MCB 788 SI						rechts/right	
	King Quad XP	750	AR41P	09-16	links/left		MCB 787 SI						links/left	
	King Quad XP	750	AR41P	09-17	rechts/right		MCB 788 SI						rechts/right	
	Ozark	250		02-		*	MCB 510 SI							
	Quad Sport	400	AK	03-		*	MCB 554 SI			MCB 626 SI				

MARCA	MODELLO	CC	TELAIO	ANNO	NOTE	DOPPO DISCO	PASTIGLIE ANT	TIPO 1	TIPO 2	PASTIGLIE POST	TIPO '1	TIPO '2	NOTE'	
MAKE	MODEL	CC	VIN	YEARS	NOTE	DOUBLE DISC	FRONT PAD	TYPE 1	TYPE 2	REAR PAD	TYPE '1	TYPE '2	NOTE'	
SUZUKI	Quadrunner	700		04-08	links/left		MCB 757 SI						links/left	
	Quadrunner	700		04-08	rechts/right		MCB 758 SI						rechts/right	
	Quadsport	50		06-19			MCS 838			MCS 901				
	Quadsport	90		07-19			MCS 901							
	Quadsport	250	AJ4AA	04-		*	MCB 510 Si							
	R Quadracer	500	AM11A	88-90		*	MCB 519 SI	EC						
	RF Quadracer	250		85		*	MCB 523 SI			MCB 510 SI				
	RH Quadzilla	500		87-		*	MCB 560 SI			MCB 561 SI	EC			
	RH/RJ/RK/RL	250		87-90		*	MCB 560 SI			MCB 626 SI				
	RL	500		90		*	MCB 560 SI			MCB 626 SI				
			80		87-06			MCS 838						
			250		88-01					MCS 842				
			450		06-	links/left		MCB 582 SI			MCB 626 SI			links/left
	SYM		450		06-	rechts/right		MCB 615 SI						rechts/right
City Max		300		06-		*	MCB 760 SI			MCB 800			4 Beläge/pads	
Quad Raider		600		08-		*	MCB 760 SI			MCB 760 SI				
Quadlander		200		06-07		*	MCB 760 SI			MCB 800 SI				
Quadlander		250	UA25A	05-10		*	MCB 760 SI			MCB 800			4 Beläge/pads	
Quadlander		300	UA30A	06-16		*	MCB 760 SI			MCB 760 SI				
TGB	Track Runner	200		05-08		*	MCB 760 SI			MCB 800 SI	SRM			
	Avenger	400		07-10		*	MCB 760 SI			MCB 760 SI				
	Avenger	500		09-10		*	MCB 760 SI			MCB 760 SI				
	Blade	250		06-07		*	MCB 523 SI			MCB 519 SI	EC			
	Blade LE, SL	325		07-		*	MCB 519 SI			MCB 523 SI				
	Blade R Target	460		12		*	MCB 519 SI	EC		MCB 523 SI				
	Blade SE	425		07-10		*	MCB 760 SI			MCB 760 SI				
	Blade SE	525		09-		*	MCB 760 SI			MCB 760 SI				
	Blade SE, SL	500		07-		*	MCB 760 SI			MCB 523 SI				
	Blade SE, SL, LT	550		09-		*	MCB 760 SI			MCB 523 SI				
	Target	325		09-11		*	MCB 519 SI	EC		MCB 523 SI				
	Target	400		09-10		*	MCB 519 SI	EC		MCB 523 SI				
	Target	425		09-11		*	MCB 519 SI	EC		MCB 523 SI				
	Target	500		09-10		*	MCB 519 SI	EC		MCB 523 SI				
	Target	525		09-11		*	MCB 519 SI	EC		MCB 523 SI				
	Target	550		10-		*	MCB 519 SI	EC		MCB 523 SI				
	YAMAHA		450	AJ20	06-09	links/left		MCB 582 SI			MCB 561 SI			links/left
		450	AJ20	06-09	rechts/right		MCB 615 SI						rechts/right	
Badger		80	4EM	95-01			MCS 962			MCS 953				
Banshee		350	3GG	90-		*	MCB 510 SI			MCB 554 SI				
Bear Tracker		250	AG01	00-04		*	MCB 510 SI							
Bear Tracker		250		99-00			MCS 833			MCS 833				
Big Bear		250	AG01	07-11		*	MCB 510 SI							
Big Bear		400	4SH	00-04		*	MCB 510 SI			MCS 958				
Big Bear		400	4SH	05-06		*	MCB 510 SI			MCB 724 SI				
Blaster		200	AG02	03-07		*	MCB 510 SI			MCB 561 SI		EC		
Blaster		200	3JM	88-02			MCS 962							
Breeze		125		89-91			MCS 962			MCS 953				
Breeze		125	3FA	92-04			MCS 962			MCS 968				

PASTIGLIE FRENO TRW ATV - UTV

MARCA	MODELLO	CC	TELAIO	ANNO	NOTE	DOPPO DISCO	PASTIGLIE ANT	TIPO 1	TIPO 2	PASTIGLIE POST	TIPO '1	TIPO'2	NOTE'
MAKE	MODEL	CC	VIN	YEARS	NOTE	DOUBLE DISC	FRONT PAD	TYPE 1	TYPE 2	REAR PAD	TYPE '1	TYPE '2	NOTE'
YAMAHA	Bruin	250	AG01	05-06		*	MCB 510 SI						
	Bruin	350	AH0, AH1	04-09		*	MCB 510 SI			MCS 958			
	ER	350		89-95			MCS 833						
	FW Big Bear	350		96-98			MCS 844			MCS 958			
	FW W-G	350		89-95			MCS 844						
	FWA Grizzly 4x4	600	AJ02	98-01		*	MCB 561 SI	EC		MCS 958			
	FWA Grizzly 4x4	660	AM03	02-08		*	MCB 561 SI			MCB 756 SI			
	FWAD Grizzly EPS	700	AM09/56/57/59	07-17	links/left		MCB 801 SI			MCB 803 SI			links/left
	FWAD Grizzly EPS	700	AM09	07-17	rechts/right		MCB 802 SI			MCB 804 SI			rechts/right
	Grizzly	80		05-08			MCS 962			MCS 953			
	Grizzly	125	AE02	04-14			MCS 962			MCS 968			
	Grizzly	300	AH3	12-14			MCB 519 SI			MCB 523 SI			
	Grizzly	400		07-08		*	MCB 510 SI			MCB 724 SI			
	Grizzly	450	AJ14/16/18	07-		*	MCB 510 SI			MCB 724 SI			
	Grizzly	550	AJ39	09-	links/left		MCB 801 SI			MCB 803 SI			links/left
	Grizzly	550	AJ39	09-	rechts/right		MCB 802 SI			MCB 804 SI			rechts/right
	Grizzly EPS	450	AJ47/48/50	11-		*	MCB 510 SI						
	Grizzly EPS	550	AJ41	09-11	links/left		MCB 801 SI			MCB 803 SI			links/left
	Grizzly EPS	550	AJ41	09-11	rechts/right		MCB 802 SI			MCB 804 SI			rechts/right
	Grizzly EPS	550	AJ53/54/58	12-	links/left		MCB 801 SI			MCB 803 SI			links/left
	Grizzly EPS	550	AJ53/54/58	12-	rechts/right		MCB 802 SI			MCB 804 SI			rechts/right
	Grizzly IRS	450	AJ14	10-12		*	MCB 510 SI						
	Grizzlyl 2x4, 4x4	350	AH1, AH2	07-		*	MCB 510 SI			MCS 958			
	Kodiak	400		93-99			MCS 844			MCS 958			
	Kodiak	450	AJ06	03-04		*	MCB 510 SI			MCB 724 SI			
	Kodiak	450	AJ14	05-07		*	MCB 510 SI			MCB 724 SI			
	Kodiak 2WD	400	AJ08	03-04		*	MCB 510 SI			MCB 724 SI			
	Kodiak 4WD	400	AJ07	03-05		*	MCB 510 SI			MCS 958			
	Kodiak 4WD	400	AJ03	00-02		*	MCB 510 SI			MCS 958			
	L Big Bear	350	4WU	99		*	MCB 510 SI			MCS 958			
	R	450	AJ42	09-	links/left		MCB 582 SI			MCB 561 SI			links/left
	R	450	AJ42	09-	rechts/right		MCB 615 SI						rechts/right
	R Raptor	350	AH1	04-		*	MCB 561 SI			MCB 561 SI			
	R Raptor	660	AM01	01-05		*	MCB 561 SI			MCB 561 SI			
	R Raptor	700	AM07	06-12	links/left		MCB 582 SI			MCB 723 SI			links/left
	R Raptor	700	AM07	06-12	rechts/right		MCB 615 SI			MCB 723 SI			rechts/right
	R Raptor	700	AM46/47/77	13-	links/left		MCB 582 SI			MCB 685			
	R Raptor	700	AM46/47/77	13-	rechts/right		MCB 615 SI			MCB 685			
	Raptor	50		04-			MCS 962			MCS 962			
	Raptor	80	AB02	02-08			MCS 962			MCS 953			
Raptor	90		10-			MCS 962			MCB 523 SI				
Raptor	250	AG03/06	08-	links/left		MCB 801 SI			MCB 561 SI			links/left	
Raptor	250	AG03/06	08-	rechts/right		MCB 802 SI						rechts/right	
Rhino	660		04-06	links/left		MCB 582 SI			MCB 723 SI			links/left	
Rhino	660		04-06	rechts/right		MCB 615 SI			MCB 723 SI			rechts/right	
Rhino	700	AM17/19/22/25	09-14	links/left		MCB 582 SI			MCB 582 SI			links/left	
Rhino	700	AM17/19/22/25	09-14	rechts/right		MCB 615 SI			MCB 582 SI			rechts/right	
T	450	AJ11	04-05	links/left		MCB 582 SI			MCB 561 SI			links/left	

MARCA	MODELLO	CC	TELAIO	ANNO	NOTE	DOPPO DISCO	PASTIGLIE ANT	TIPO 1	TIPO 2	PASTIGLIE POST	TIPO '1	TIPO'2	NOTE'
MAKE	MODEL	CC	VIN	YEARS	NOTE	DOUBLE DISC	FRONT PAD	TYPE 1	TYPE 2	REAR PAD	TYPE '1	TYPE '2	NOTE'
YAMAHA	T	450	AJ11	04-05	rechts/right		MCB 615 SI						rechts/right
	Timberwolf	250		92-94			MCS 962			MCS 833			
	Timberwolf	250		94-00			MCS 833			MCS 833			
	UH, UJ, UK	350		96-98			MCS 844			MCS 833			
	Wolverine	350	AH4, 4KB	95-05		*	MCB 510 SI			MCS 958			
	Wolverine	450	AJ21/23	06-11	links/left		MCB 582 SI			MCB 724 SI			links/left
	Wolverine	450	AJ21/23	06-11	rechts/right		MCB 615 SI						rechts/right
	X Warrior	350	3GD	89-04		*	MCB 510 SI			MCB 554 SI			



TPR
FACTORY

cod. 99CRPT0700 per Piaggio 70cc - cod. 99CRPT1000 per Piaggio 100cc

CARATTERISTICHE TECNICHE

- Costruito in **Lega 6082 Anticorodal** (Lega Al-Si-Mg-Mn)
- Carter pompa dimensionati per l'installazione di alberi motore con **corsa fino a 47mm** con interasse biella 95/96mm, senza alcun intervento aggiuntivo.
- Alloggiamento esclusivo per l'accensione a rotore interno **PVL**.
- L'utilizzo della pompa di raffreddamento elettrica, per **eliminare l'assorbimento di potenza** della tradizionale pompa meccanica.
- Sedi dei cuscinetti allargate e maggiorate con caratteristiche particolari
- Sezioni passaggio liquido di raffreddamento maggiorate

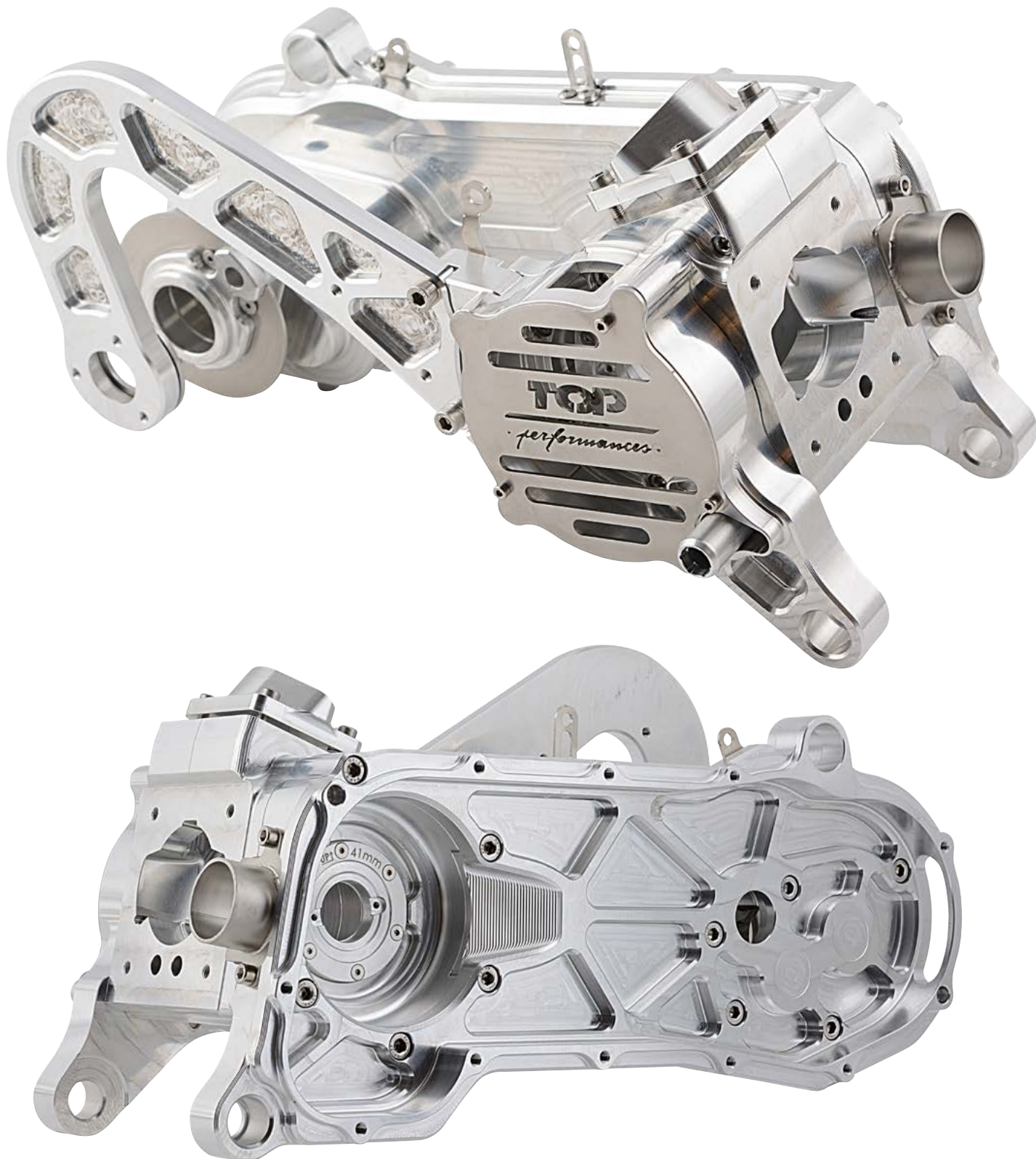

VERSIONI E COMPATIBILITÀ

Particolare attenzione è stata dedicata ad una compatibilità assoluta.

Con questo carter, possiamo intercambiare:

- Semicamere (70cc / 100cc / prototipi)
- Monobraccio (lungo / corto)
- Sistema frenate (disco / tamburo)
- Modello (Piaggio / Minarelli)

Versioni disponibili:

- Piaggio 70cc cod. 99CRPT0700
- Piaggio 100cc cod. 99CRPT1000

****POSSIBILITÀ DI SODDISFARE QUALUNQUE APPLICAZIONE CON UN'UNICA SEMICAMERA**

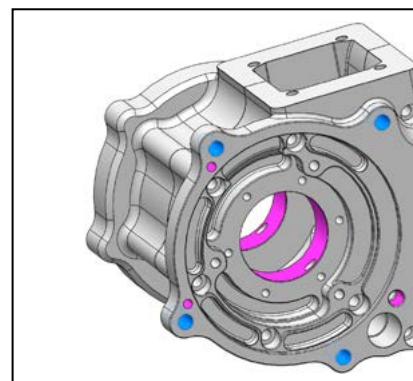

PASSO ALLUNGATO

Il passo è stato allungato traslando la posizione dell'asse ruota di 10mm verso il retrotreno e 10mm verso l'asfalto.

Questa soluzione migliora la ciclistica e permette di utilizzare l'ammortizzatore posteriore con 10mm in meno di lunghezza, riducendo l'inclinazione dell'alimentazione e del carter.

****MANTIENE INVARIATA LA LUNGHEZZA TRASMISSIONE ED I RAPPORTI (possibilità di montare qualunque marchio)**

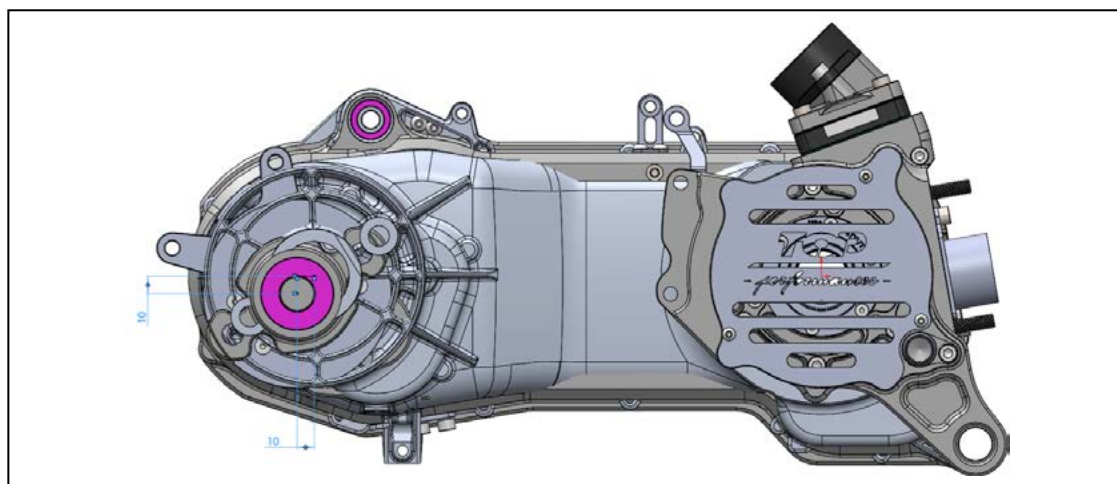

CAMBIO ROVESCiato AD INTERASSE ALLUNGATO

La scatola rapporti è stata radicalmente innovata, introducendo l'incremento del passo.

È stata rovesciata con apertura verso l'esterno

Ciò permette di eliminare il coperchio rapporti, migliorando la precisione delle coassialità, inoltre un o-ring garantisce una tenuta ottimale dell'olio.

****MANTIENE INVARIATA LA LUNGHEZZA TRASMISSIONE ED I RAPPORTI (possibilità di montare qualunque marchio)**

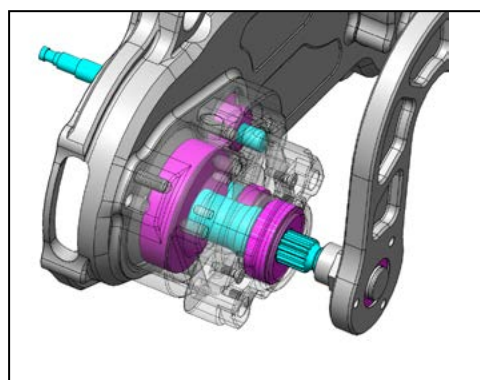

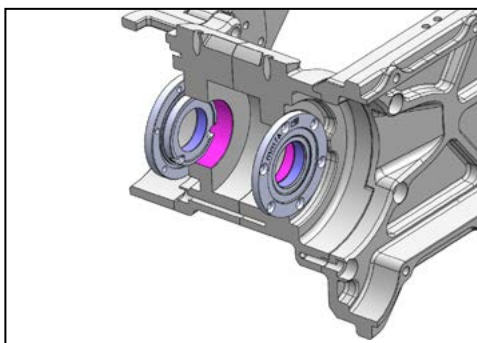

PARAOLI FLANGIATI

L'alloggiamento dei paraoli ora prevede due boccole flangiate, ciò permette di eseguire le barenature di entrambi i cuscinetti in una sola operazione, insieme al piano di appoggio del cilindro ottenendo una concentricità ed una tolleranza diametrica assoluta di entrambe le sedi. Diminuendo lo sforzo dell'albero sui cuscinetti ed aumentando la potenza e l'erogazione.

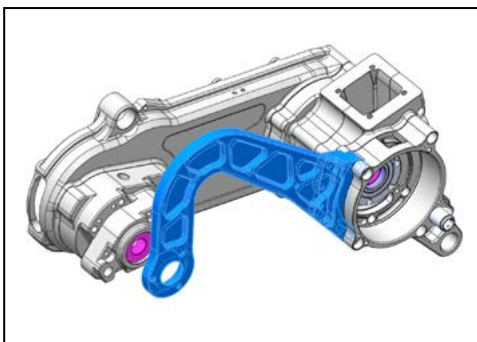

TORSEN INTEGRATO SCOMPONIBILE

Completamente rivisto, ora il torsen prevede l'attacco su un diametro nettamente più compatto, senza agire sui fori dello scarico (come invece avviene per tutti i concorrenti). Ciò permette di avere un collegamento molto più solido e sono previste anche due spine calibrate per un allineamento perfetto. Inoltre la sezione da oltre 14mm, risulta molto più robusta rispetto alle altre proposte.

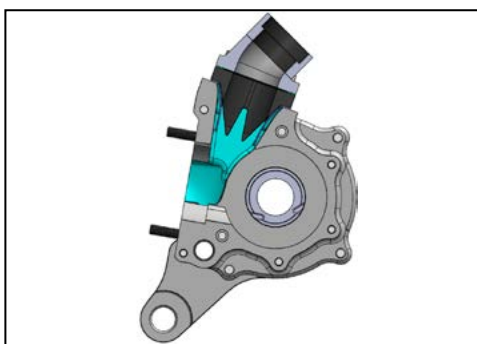

ALIMENTAZIONE MAGGIORATA

L'alimentazione si presenta radicalmente riprogettata. Oltre a poter alloggiare valvole e carburatori maggiorati, permette anche una migliore disposizione del carburatore rispetto alla ruota. Inoltre grazie ad un doppio schema di foratura è possibile montare sia valvole maggiorate che valvole già in uso, con interasse 60x40 (es. AM6)

****CON FORATURE COMMERCIALI (possibilità di montare qualunque marchio)**

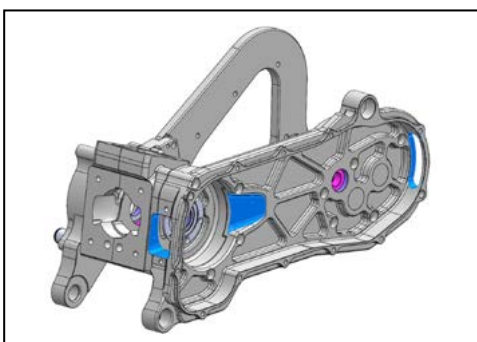

VENTILAZIONE OTTIMIZZATA

La ventilazione della zona trasmissione è stata nettamente ottimizzata. Molti problemi sono causati dalle temperature elevate; ora presenta due generosi passaggi (in ingresso ed in uscita) ed anche una zona centrale di estrazione per il variatore. Possibilità di installare portate forzate sulla presa d'aria in ingresso.

****MANTIENE LA POSSIBILITÀ DI ALLOGGIARE QUALUNQUE TRASMISSIONE (possibilità di montare qualunque marchio)**

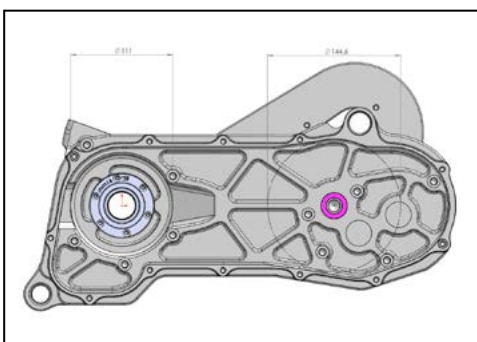

SEDE TRASMISSIONE MAGGIORATA

Di serie la sede della trasmissione è sottodimensionata per la piena escursione dei componenti, portando frequentemente la cinghia a strisciamenti e rotture. Ora sono previsti diametri di ingombro per variatori fino a 111mm e per i correttori fino a 145mm. A parità di utilizzo, la maggior volumetria genera inoltre anche una migliore dissipazione del calore

****MANTIENE LA POSSIBILITÀ DI ALLOGGIARE QUALUNQUE TRASMISSIONE**

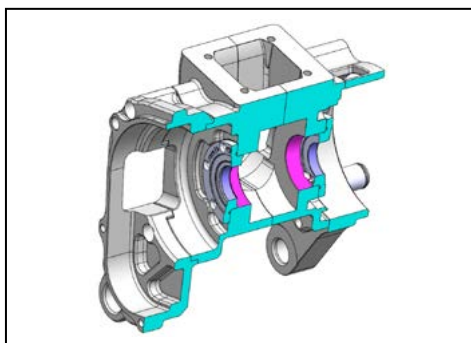

SEZIONE RESISTENTE ZONA ALBERO

Ad oggi nessun carter motore può vantare una tale resistenza nella zona albero motore. Tale sezione garantisce una planarità ed una qualità degli accoppiamenti più duratura. Tutte le lavorazioni vengono gestite su un centro di lavoro 5Assi pallettizzato leader nel settore Automotive e certificati su macchine di misura.

****MIGLIORE VALORE NEL SETTORE**

****MANTIENE LA POSSIBILITÀ DI ALLOGGIARE QUALUNQUE ALBERO E TRASMISSIONE**

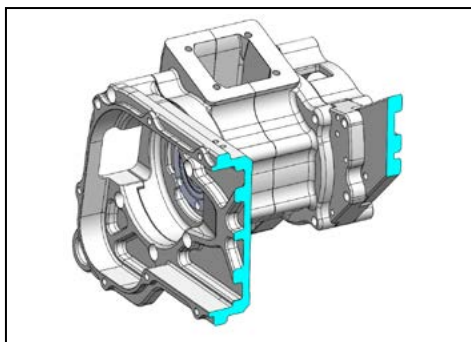

SEZIONE RESISTENTE ZONA TRASMISSIONE

Ad oggi nessun carter motore può vantare una tale resistenza nella zona trasmissione. Utilizzando il metodo degli elementi finiti FEM (Finite Element Method) è stata bilanciata e compensata la struttura del monobraccio, annullando di fatto qualsiasi momento torcente dato dal carico a sbalzo dell'asse ruota. Grazie alla spinatura di centraggio di tutti i componenti, migliora l'allineamento rispetto alle altre soluzioni.

****MANTIENE LA POSSIBILITÀ DI ALLOGGIARE QUALUNQUE TIPO DI TRASMISSIONE**

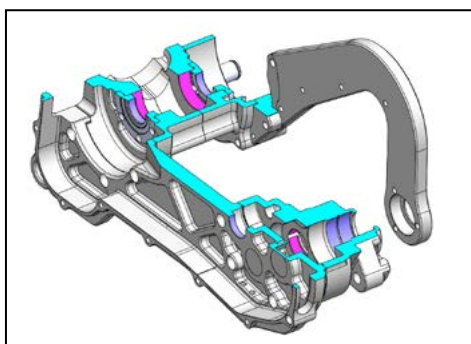

SEZIONE RESISTENTE ZONA ASSE RUOTA

Tramite simulazioni al FEM è stata incrementata la struttura nella scatola rapporti. Oltre all'aumento delle sollecitazioni abbiamo considerato l'adozione totale della cuscinetteria per migliorare l'alloggio dei rapporti, diminuendo i disallineamenti dei rapporti che generano calore e diminuiscono la potenza alla ruota.

****MANTIENE LA POSSIBILITÀ DI ALLOGGIARE QUALUNQUE TIPO DI RAPPORTI ED ASSI RUOTA**

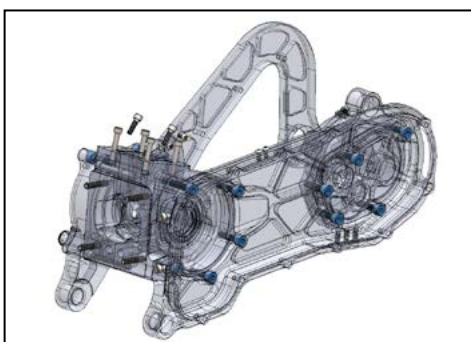

VITERIA MAGGIORATA

Motori sempre più performanti necessitano di estrema sicurezza negli accoppiamenti. Ad oggi l'impiego di Viteria M6 su alluminio risulta sottodimensionato e critico nei carter disponibili sul mercato.

Siamo riusciti a riprogettare tutto il carter con viteria M8 per tutti gli accoppiamenti (con sezione resistente +70% rispetto ad un M6).

Ciò aumenta la stabilità ed il grado di sicurezza dell'utilizzatore

****UNICO CARTER AD ADOTTARE FILETTATURE M8 PER TORSEN-MONOBRACCIO-RAPPORTI**

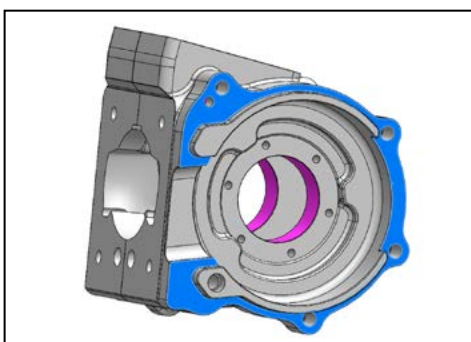

ACCOPIAMENTO MONOBRACCIO

Un approfondito studio per ottimizzare l'accoppiamento tra Semicamera e Monobraccio garantisce un impiego stabile e duraturo.

Oltre al centraggio e la fase, è stata posta particolare attenzione anche alla distribuzione omogenea del carico delle viti, posizionandole in zone equidistanti tra di loro e dal centro, completamente in acciaio altoresistenziale ad elevata inossidabilità, con testa cilindrica e filettatura metrica M8

****MANTIENE LA POSSIBILITÀ DI ALLOGGIARE QUALUNQUE ALBERO E TRASMISSIONE**

COPERCHIO FRIZIONE IN ALLUMINIO Cod. 99CFAMA10**COPERCHIO FRIZIONE IN ALLUMINIO TRASPARENTE Cod. 99CFAMT10**

**Coperchio frizione TPR Factory per motori AM
Progettato e realizzato per utilizzo esclusivamente agonistico.**

Costruito in pregiata **Lega 6082 Anticorodal** (Lega alluminio-silicio-magnesio-manganese) il coperchio frizione TPR Factory è completamente **ricavato dal pieno** su centri di lavoro CNC ed è corredato di viteria e guarnizioni necessarie al montaggio su tutti i veicoli equipaggiati con motore AM 3-4-5-6. Il coperchio frizione **scomponibile** offre la possibilità di ispezionare o sostituire i componenti della frizione senza dover togliere l'olio motore ed il liquido di raffreddamento, garantendo l'aumento delle **prestazioni** tramite l'eliminazione del miscelatore automatico e degli attriti da esso derivati.



Cod. 99CFAMA10

Carter frizione trasparente in alluminio ricavato dal pieno per motori MInarelli AM
Kit completo di guarnizione e bulloneria



Cod. 99CFAMA20

Cover coperchio frizione in alluminio



Cod. 99CFAMT10

Carter frizione trasparente in alluminio ricavato dal pieno per motori MInarelli AM
Kit completo di guarnizione e bulloneria

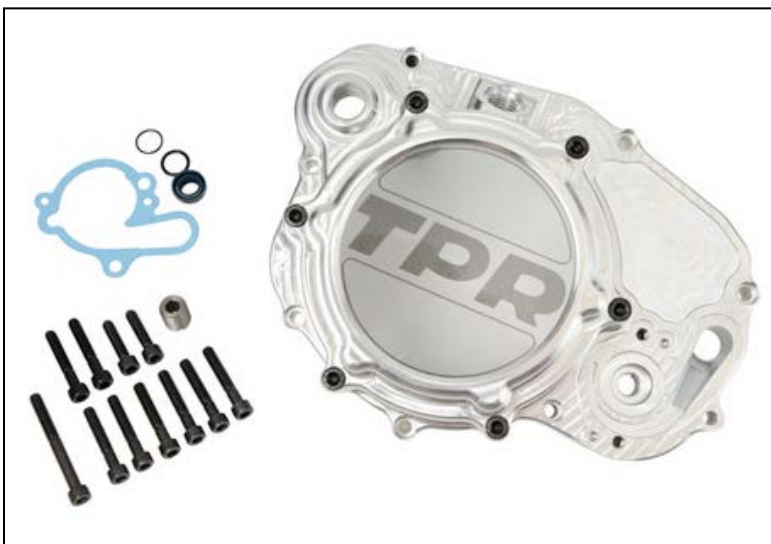

Cod. 99CFAMT20

Cover coperchio frizione in alluminio trasparente



Cod. 9937850 - OPZIONALE

Kit chiusura Kick Starter per coperchio frizione TPR Factory

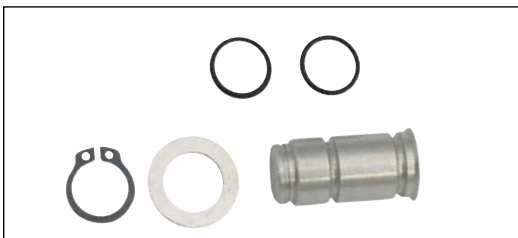

Filtri aria Racing TPR Factory per motori AM
Progettato e realizzato per utilizzo esclusivamente agonistico.



Cod. 99AF7070R

Filtro aria TPR Factory imbocco ø70 rosso



Cod. 99AF2843R

Filtro aria TPR Factory imbocco ø28-32-36-39-43 rosso



Cod. 99AF4662R

Filtro aria TPR Factory imbocco ø46-49-52-55-58-62 rosso

Cod. 99AF7070B

Filtro aria TPR Factory imbocco ø70 blu



Cod. 99AF7070N

Filtro aria TPR Factory imbocco ø70 nero



Cod. 99AF2843B

Filtro aria TPR Factory imbocco ø28-32-36-39-43 blu



Cod. 99AF2843N

Filtro aria TPR Factory imbocco ø28-32-36-39-43 nero



Cod. 99AF4662N

Filtro aria TPR Factory imbocco ø46-49-52-55-58-62 blu



Cod. 99AF4662N

Filtro aria TPR Factory imbocco ø46-49-52-55-58-62 nero



Cod. 99GT525000 - Gruppo termico Ø52 TPR Factory 100cc

- In alluminio con riporto galvanico
- Alesaggio Ø52
- Corsa 47mm
- Luce di scarico sdoppiata
- 6 travasi
- **Applicabilità:**
 - Interasse fissaggio cilindro compatibile con Carter TPR Factory ed altri produttori

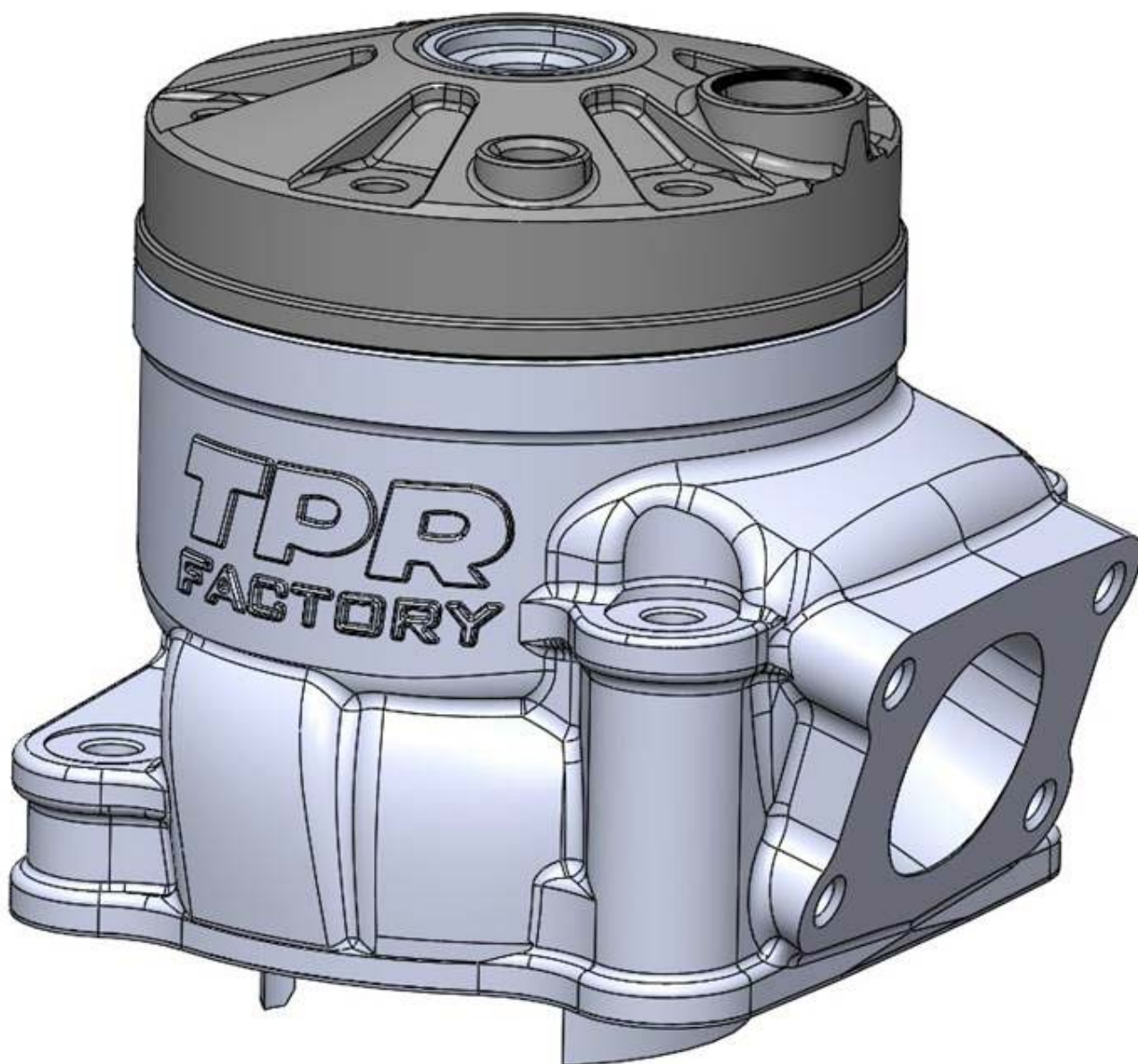
COMING SOON

Cod. 99AL47S000 - Albero motore TPR Factory 100cc scooter

- Acciaio 18NiCrMo5 forgiato
- Corsa 47mm
- Diametro - larghezza spalle $\varnothing 84 - 44$ mm
- Gabbia a rulli argentata
- Asse accoppiamento $\varnothing 20$ mm
- Bilanciamento dinamico a 18000 rpm
- Inserti in Tungsteno per bilanciatura
- Peso Albero completo 2,030 Kg
- Biella interasse 98 mm in acciaio 18NiCrMo5 forgiato-

Applicazioni:

- Carter TPR Factory



Cod. 99F5MAM10 - Kit frizione Racing TPR Factory 5 molle per motori AM

- Superficie materiale di attrito **maggiorata del 25%** grazie ad 1 disco rivestito ed 1 disco in acciaio in più rispetto all'originale
- Migliore distribuzione della pressione specifica grazie all'utilizzo di **5 molle** (1 in più dell'originale)
- Tamburo e spingidisco in alluminio **anticorodal** ricavati da pieno con macchine CNC 5 assi
- Tamburo con anodizzazione militare, spessore **40 micron** e durezza superficiale superiore ai 500 HV
- Spingidisco con anodizzazione anticorrosiva, spessore **40 Micron**
- **Applicabilità:**
 - Tutti i motori Minarelli della serie AM, AM3, AM4, AM5, AM6 prima e seconda generazione

APRILIA	CLASSIC 50 2T 92-99, EUROPA 50 2T 91-92, MX 50 2T 04-04, MX MOTARD 50 2T 95-03, PEGASO 50 2T 92-94, RS 50 2T 91-05, RX 50 2T 03-04, RX 3-5 MARCE 50 2T 91-94, RX ENDURO 50 2T 95-03, RX RACING 50 2T 03-06, TUONO 50 2T 03-04	FANTIC	CABALLERO MOTARD 50 2T 06-10, CABALLERO MOTARD COMPETITION 50 2T 06-10, CABALLERO REGOLARITÀ 50 2T 06-10, CABALLERO REGOLARITÀ COMPETITION 50 2T 06-10, ENDURO COMPETITION EU4 50 2T 18-20, ENDURO PERFORMANCE EU4 50 2T 18-20, MOTARD COMPETITION EU4 50 2T 18-20, MOTARD PERFORMANCE EU4 50 2T 18-20	PEUGEOT	SUPERMOTARD 50 2T 90-02, XP6 TRAIL S/AVV. ELETTRICO 50 2T 90-02, XR6 RACING CAT. C/AVV.ELETT. 50 2T 90-02		
BETA	RR 2T 50 EU4 50 2T 18-20, RR 50 RACING EU4 50 2T 18-20, RR ALU 50 2T 08-12, RR ENDURO 50 2T 06-17, RR MOTARD 50 2T 06-17	HM	BAJA, DERAPAGE BASIC 50 2T 10-11, CMC 50 2T 10-11, CRE BAJA RR, DERAPAGE RR 50 2T 07-11, CRE BAJA, DERAPAGE 50 2T 07-11, CRE SIX COMPETITION 50 2T 10-11, CRE SIX, BAJA, DERAPAGE 50 2T 95-06, CRE SIX, DERAPAGE COMPETITION 50 2T 07-09, DERAPAGE COMPETITION 50 2T 10-11	RIEJU	MRT 50 2T 09-12, MRT 50 EU4 50 2T 18-20, MRT PRO 50 2T 09-12, MRT PRO EU4 50 2T 18-20, MRT PRO REPLICA EU4 50 2T 18-20, MRT PRO REPLICA SM EU4 50 2T 18-20, MRT PRO SM 50 2T 09-12, MRT PRO SM EU4 50 2T 18-20, MRT SM 50 2T 09-12, MRT SM EU4 50 2T 18-20, MRT TROPHY EU4 50 2T 18-20, MRX 50 2T 01-04, MRX PRO 50 2T 01-04, RR 50 2T 05-06, RS1 50 2T 98-01, RS2 MATRIX 50 2T 05-06, RS2 MATRIX PRO 50 2T 05-06, RS2 NAKED 50 2T 04-05, RS3 EU4 50 2T 18-20, RS3 NKD EU4 50 2T 18-20, SMX E.S./K.S. 50 2T 01-01, SMX PRO E.S./K.S. 50 2T 03-03, SPIKE 50 2T 98-01	SHERCO	FACTORY SE-R EU4 50 2T 18-20, FACTORY SE-RS EU4 50 2T 18-20, FACTORY SILVER SM-R EU4 50 2T 18-20, FACTORY SILVER SM-RS EU4 50 2T 18-20, FACTORY SM-R EU4 50 2T 18-20, FACTORY SM-RS EU4 50 2T 18-20, HRD ENDURO 50 2T 09-13, HRD MOTARD 50 2T 09-13
CH HUSQUARNA	SM 50 2T 00-10, WR 50 2T 00-10, WSM 50 2T 00-10	MALAGUTI	CNK DRAGON 50 2T 05-07, FIFTY EVOLUTION 50 2T 90-93, XSM 50 2T 03-06, XSM POWER-UP 50 2T 07-10, XTM 50 2T 03-03, XTM 50 2T 06-06, XTM POWER-UP 50 2T 07-10	YAMAHA	DT R 50 2T 03-11, DT RSM 50 2T 03-05, DT X 50 2T 06-11, TZR 50 2T 03-08, TZR 50 2T 10-11, TZR RR 50 2T 05-05		
CMC	ENDURO 50 2T 11-11, MOTARD 50 2T 11-11	MBK	X LIMIT 50 2T 03-04, X POWER 50 2T 03-04				
FANTIC	CABALLERO MOTARD 50 2T 06-10, CABALLERO MOTARD COMPETITION 50 2T 06-10, CABALLERO REGOLARITÀ 50 2T 06-10, CABALLERO REGOLARITÀ COMPETITION 50 2T 06-10, ENDURO COMPETITION EU4 50 2T 18-20, ENDURO PERFORMANCE EU4 50 2T 18-20, MOTARD COMPETITION EU4 50 2T 18-20, MOTARD PERFORMANCE EU4 50 2T 18-20	MINARELLI	MOTORE AM 3-4-5 50 2T 91-95				
		MOTORHISPANIA	FURIA 50 2T 97-00, FURIA MAX 50 2T 10-12, RX 50 2T 09-12, RX R 50 2T 09-12				



Cod. 99PFR0010 - Pinza freno radiale TPR Factory

- Pinza Freno radiale racing in **Avional** con interasse fissaggio 84 mm, pistoncini in Inox rettificato ed attacco tubo freno M8x1.
- Completa di **pastiglie sinterizzate**, Vite M8x1 per raccordi Ø10 e M8x1 per raccordi Ø8.
- La struttura, sviluppata utilizzando il **metodo degli elementi finiti FEM** (Finite Element Method), garantisce rigidità.
- Le finiture di pistoncini e tenute garantiscono **modulabilità e precisione** della frenata.
- **Applicazioni:**
 - KTM SX/SXS 85
 - OHVALE GP-0
 - Compatibile con pinze VOCA, Stage6, Formula, 8.1, PIT BIKE



Ricambi

99PFR0012	Kit 4 pistoncini inox
99PFR0020	Kit revisione pinza freno radiale TPR Factory
99PFRA080	Kit vite M8x1 per raccordo Ø8 con rondelle
99PFRA100	Kit vite M8x1 per raccordo Ø10 con rondelle
MCB842SI	Pads front

cod. 99PFR0020 Kit revisione pinza

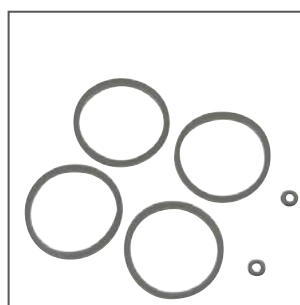

cod. 99PFR0012 Kit 4 pistoncini INOX





TOP[®]
- *performances* -

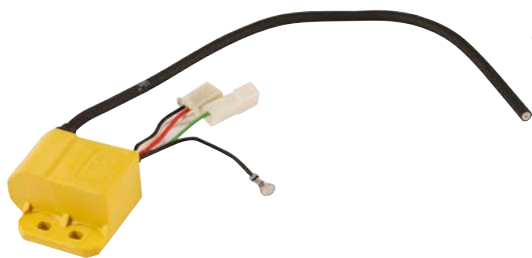

◀ **cod. 9910090**
Centralina ad anticipo fisso 6 poli Ducati

APPLICABILITÀ

BETA ARK 50 2T 96-08, ARK LC 50 2T 96-08, CHRONO 50 2T 95-96, QUADRA 50 2T 95-95, QUADRA 50 2T 99-01, TEMPO 50 2T 93-02, TEMPO 50 2T 95-95
KTM K50 50 2T 96-01
MACAL STING 50 2T 95-96, THUNDER 50 2T 95-96

MALAGUTI CENTRO SL 50 2T 94-98, CIAK 50 2T 99-01, CIAK EURO2 50 2T 01-03, F10 50 2T 92-00, F10 EURO 2 50 2T 02-06, F12 PHANTOM 50 2T 94-98, F12 PHANTOM LC 50 2T 94-98, F12 RESTYLING EURO 1 50 2T 99-02, F15 FIRE FOX 50 2T 96-98, YESTERDAY 50 2T 97-00

MOTRON STING 50 2T 95-96, SYNCRO 50 2T 98-00, THUNDER 50 2T 95-98



◀ **cod. 9910150**
Centralina ad anticipo fisso 6 poli per motori Minarelli AM

APPLICABILITÀ

APRILIA CLASSIC 50 2T 92-99, EUROPA 50 2T 91-92, MX 50 2T 04-04, MX MOTARD 50 2T 95-03, PEGASO 50 2T 92-94, RS 50 2T 91-05, RX 50 2T 03-04, RX 3-5 MARCE 50 2T 91-94, RX ENDURO 50 2T 95-03, RX RACING 50 2T 03-06, TUONO 50 2T 03-04
CH HUSQVARNA SM 50 2T 00-10, WR 50 2T 00-10, WSM 50 2T 00-10
HM CRE SIX, BAIA, DERAPAGE 50 2T 95-05
MALAGUTI CNK DRAGON 50 2T 05-07, FIFTY EVOLUTION 50 2T 90-93, XSM 50 2T 03-03, XTM 50 2T 03-03
MBK X LIMIT 50 2T 03-04, X POWER 50 2T 03-04
MOTOR HISPANIA FURIA 50 2T 97-00, FURIA MAX 50 2T 10-12, RX 50 2T 09-12, RX R 50 2T 09-12

PEUGEOT SUPERMOTARD 50 2T 90-02, XP6 TRAIL S/AVV. ELETTRICO 50 2T 90-02, XR6 RACING CAT. C/AVV.ELETT. 50 2T 90-02

RIEJU MRT 50 2T 09-12, MRT PRO 50 2T 09-12, MRT PRO SM 50 2T 09-12, MRT SM 50 2T 09-12, MRX 50 2T 01-04, MRX PRO 50 2T 01-04, RR 50 2T 05-06, RS1 50 2T 98-01, RS2 MATRIX 50 2T 05-06, RS2 MATRIX PRO 50 2T 05-06, RS2 NAKED 50 2T 04-05, SMX E.S./K.S. 50 2T 01-01, SMX PRO E.S./K.S. 50 2T 03-03, SPIKE 50 2T 98-01

SHERCO HRD ENDURO 50 2T 09-13, HRD MOTARD 50 2T 09-13

YAMAHA DT R 50 2T 03-06, DT RSM 50 2T 03-05, DT X 50 2T 06-06

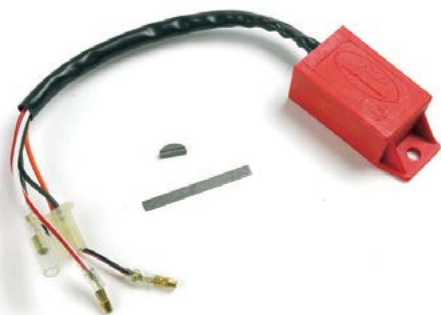

◀ **cod. 9909230**
Centralina ad anticipo variabile per motore orizzontale (Japan)

APPLICABILITÀ

APRILIA AREA 51 50 2T 98-00, GULLIVER 50 2T 95-98, GULLIVER LC 50 2T 96-98, RALLY 50 2T 95-03, RALLY LIQUID COOLED 50 2T 96-99, SCARABEO 50 2T 93-05, SONIC 50 2T 98-07, SONIC GP 50 2T 98-08, SR (ORIZZONTALE) 50 2T 94-96, SR LIQUID COOLED 50 2T 94-96, SR RACING 50 2T 97-99, SR STEALTH 50 2T 97-00, SR WWW 50 2T 97-01
BENELLI 491 GT 50 2T 98-99, 491 NAKED 50 2T 02-02, 491 RACING 50 2T 98-99, 491 RR 50 2T 99-01, 491 SP 50 2T 99-99, 491 SPORT 50 2T 98-99, 491 ST 50 2T 99-01, K2 50 2T 98-01, K2 LIQUID COOLED 50 2T 98-01, PEPE 50 2T 99-01, PEPE LX 50 2T 03-04
BETA CHRONO 50 2T 95-97, QUADRA 50 2T 99-01, TEMPO 50 2T 93-02
ITALJET DRAGSTER 50 2T 98-02

MBK BOOSTER 50 2T 90-04, BOOSTER 50 2T 90-94, BOOSTER NG 50 2T 95-03, BOOSTER ROCKET 50 2T 97-98, BOOSTER SPIRIT 50 2T 96-00, BOOSTER TRACK 50 2T 96-98, EVOLIS 50 2T 92-95, FIZZ 50 2T 94-95, FLIPPER 50 2T 98-04, NITRO 50 2T 97-04, OVETTO 50 2T 97-04, STUNT 50 2T 00-02

YAMAHA EROX 50 2T 97-02, AEROX 50 2T 04-16, AEROX NAKED 50 2T 13-16, AEROX R 50 2T 99-00, AEROX R 50 2T 99-99, AXIS 50 2T 95-96, BREEZE 50 2T 94-95, BW'S 50 2T 97-04, BW'S BUMP 50 2T 97-98, BW'S NAKED 50 2T 03-03, BW'S NEXT GENERATION 50 2T 97-00, BW'S NEXT GENERATION 50 2T 99-02, BW'S ORIGINAL 50 2T 99-00, BW'S ORIGINAL 50 2T 99-02, JOG 50 2T 92-01, JOG ER 50 2T 00-02, JOG Z 50 2T 95-95, NEO'S 50 2T 97-02, RS SPY 50 2T 95-98, SLIDER 50 2T 00-02, WHY 50 2T 98-05, ZEST 50 2T 95-92, ZUMA 50 2T 97-01

RICAMBI

9909180	Chiavetta disassata per anticipo variabile
----------------	--

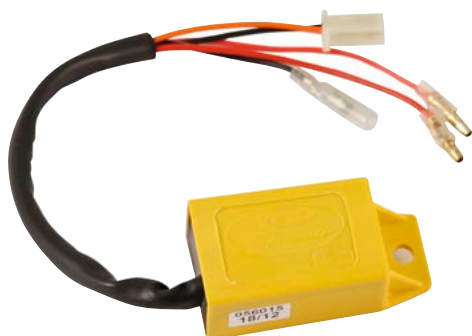

◀ **cod. 9910100**
Centralina ad anticipo fisso per motori scooter 50 cc Minarelli/Yamaha

APPLICABILITÀ

APRILIA AREA 51 50 2T 98-00, GULLIVER 50 2T 95-98, GULLIVER LC 50 2T 96-98, RALLY 50 2T 95-03, RALLY LIQUID COOLED 50 2T 96-99, SCARABEO 50 2T 93-05, SONIC 50 2T 98-07, SONIC GP 50 2T 98-08, SR (ORIZZONTALE) 50 2T 94-96, SR LIQUID COOLED 50 2T 94-96, SR RACING 50 2T 97-99, SR STEALTH 50 2T 97-00, SR WWW 50 2T 97-01
BENELLI 491 GT 50 2T 98-99, 491 NAKED 50 2T 02-02, 491 RACING 50 2T 98-99, 491 RR 50 2T 99-01, 491 SP 50 2T 99-99, 491 SPORT 50 2T 98-99, 491 ST 50 2T 99-01, K2 50 2T 98-01, K2 LIQUID COOLED 50 2T 98-01, PEPE 50 2T 99-01, PEPE LX 50 2T 03-04
BETA CHRONO 50 2T 95-97, EIKON 50 2T 99-03, QUADRA 50 2T 99-01, TEMPO 50 2T 93-02
ITALJET DRAGSTER 50 2T 98-02

MBK BOOSTER 50 2T 90-04, BOOSTER 50 2T 90-94, BOOSTER NG 50 2T 95-03, BOOSTER ROCKET 50 2T 97-98, BOOSTER SPIRIT 50 2T 96-00, BOOSTER TRACK 50 2T 96-98, EVOLIS 50 2T 92-95, FIZZ 50 2T 94-95, FLIPPER 50 2T 98-04, NITRO 50 2T 97-04, OVETTO 50 2T 97-04, STUNT 50 2T 00-02

YAMAHA AEROX 50 2T 97-02, AEROX 50 2T 04-16, AEROX NAKED 50 2T 13-16, AEROX R 50 2T 99-00, AEROX R 50 2T 99-99, AXIS 50 2T 95-96, BREEZE 50 2T 94-95, BW'S 50 2T 97-04, BW'S BUMP 50 2T 97-98, BW'S NAKED 50 2T 03-03, BW'S NEXT GENERATION 50 2T 97-00, BW'S NEXT GENERATION 50 2T 99-02, BW'S ORIGINAL 50 2T 99-00, BW'S ORIGINAL 50 2T 99-02, JOG 50 2T 92-01, JOG ER 50 2T 00-02, JOG Z 50 2T 95-95, NEO'S 50 2T 97-02, RS SPY 50 2T 95-98, SLIDER 50 2T 00-02, WHY 50 2T 98-05, ZEST 50 2T 95-92, ZUMA 50 2T 97-01



◀ cod. **9921210**
Centralina digitale ad anticipo variabile per scooter 50 cc

APPLICABILITÀ

MALAGUTI CIAK EURO 2,2,3 50 2T 03-03, F10 EURO 2,2,3 50 2T 03-04, F12 PHANTOM EURO 2,2,3 50 2T 03-04, F12 PHANTOM LC EURO 2,2,3 50 2T 03-04, F15 FIRE FOX EURO 2,2,3 50 2T 03-04



◀ cod. **9921690**
Centralina digitale ad anticipo variabile per motori Minarelli AM6 con volano Ducati 6 poli

APPLICABILITÀ

APRILIA CLASSIC 50 2T 92-99, EUROPA 50 2T 91-92, MX 50 2T 04-04, MX MOTARD 50 2T 95-03, PEGASO 50 2T 92-94, RS 50 2T 91-05, RX 50 2T 03-04, RX 3-5 MARCE 50 2T 91-94, RX ENDURO 50 2T 95-03, RX RACING 50 2T 03-06, TUONO 50 2T 03-04

CH HUSQVARNA SM 50 2T 00-10, WR 50 2T 00-10, WSM 50 2T 00-10

FANTIC CABALLERO MOTARD 50 2T 06-10, CABALLERO REGOLARITÀ 50 2T 06-10

HM CRE SIX, BAIA, DERAPAGE 50 2T 95-05

MALAGUTI CNK DRAGON 50 2T 05-07, FIFTY EVOLUTION 50 2T 90-93, XSM 50 2T 03-03, XTM 50 2T 03-03

MBK X LIMIT 50 2T 03-04, X POWER 50 2T 03-04

MOTOR HISPANIA FURIA 50 2T 97-00, FURIA MAX 50 2T 10-12, RX 50 2T 09-12, RX R 50 2T 09-12

PEUGEOT SUPERMOTARD 50 2T 90-02, XP6 TRAIL S/AVV. ELETTRICO 50 2T 90-02, XR6 RACING CAT. C/AVV.ELETT. 50 2T 90-02

RIEJU MRX 50 2T 01-04, MRX PRO 50 2T 01-04, RR 50 2T 05-06, RS1 50 2T 98-01, RS2 MATRIX 50 2T 05-06, RS2 MATRIX PRO 50 2T 05-06, RS2 NAKED 50 2T 04-05, SMX E.S./K.S. 50 2T 01-01, SMX PRO E.S./K.S. 50 2T 03-03, SPIKE 50 2T 98-01

SHERCO HRD ENDURO 50 2T 09-13, HRD MOTARD 50 2T 09-13

YAMAHA DT R 50 2T 03-06, DT RSM 50 2T 03-05, DT X 50 2T 06-06



◀ cod. **9924870**
Centralina con bobina ad anticipo fisso

APPLICABILITÀ

GILERA DNA 50 2T 00-02, DNA GP EXPERIENCE 50 2T 03-04, EASY MOVING 50 2T 95-96, ICE 50 2T 01-05, RUNNER 50 2T 97-00, RUNNER POGGIALI 50 2T 02-02, RUNNER SP 50 2T 02-04, STALKER 50 2T 97-04, STORM 50 2T 94-95, TYPHOON 50 2T 94-97, TYPHOON X 50 2T 98-99, TYPHOON XR 50 2T 00-00

ITALJET JET SET 50 2T 02-02, TORPEDO NEW 50 2T 00-01

PIAGGIO FREE 50 2T 92-94, FREE DELIVERY 50 2T 00-01, FREE FL 50 2T 95-02, LIBERTY 50 2T 97-05, NRG EXTREME LC 50 2T 99-00, NRG MC3 50 2T 01-04, NRG RST MC2 50 2T 96-98, NTT 50 2T 95-96, QUARTZ 50 2T 92-96, SFERA 50 2T 91-93, SFERA MAQUILLAGE 2 50 2T 94-94, SFERA RST 50 2T 95-97, VESPA ET2 50 2T 97-05, ZIP 50 2T 92-93, ZIP 50 2T 95-96, ZIP BIMODALE 50 2T 94-97, ZIP FAST RIDER 50 2T 93-94, ZIP FAST RIDER RST 50 2T 96-97, ZIP RST 50 2T 96-99, ZIP SP 50 2T 96-00



◀ cod. **9924880**
Centralina con bobina ad anticipo variabile

APPLICABILITÀ

GILERA DNA 50 2T 00-02, DNA GP EXPERIENCE 50 2T 03-04, EASY MOVING 50 2T 95-96, ICE 50 2T 01-05, RUNNER 50 2T 97-00, RUNNER POGGIALI 50 2T 02-02, RUNNER SP 50 2T 02-04, STALKER 50 2T 97-04, STORM 50 2T 94-95, TYPHOON 50 2T 94-97, TYPHOON X 50 2T 98-99, TYPHOON XR 50 2T 00-00

ITALJET JET SET 50 2T 02-02, TORPEDO NEW 50 2T 00-01

PIAGGIO FREE 50 2T 92-94, FREE DELIVERY 50 2T 00-01, FREE FL 50 2T 95-02, LIBERTY 50 2T 97-05, NRG EXTREME LC 50 2T 99-00, NRG MC3 50 2T 01-04, NRG RST MC2 50 2T 96-98, NTT 50 2T 95-96, QUARTZ 50 2T 92-96, SFERA 50 2T 91-93, SFERA MAQUILLAGE 2 50 2T 94-94, SFERA RST 50 2T 95-97, VESPA ET2 50 2T 97-05, ZIP 50 2T 92-93, ZIP 50 2T 95-96, ZIP BIMODALE 50 2T 94-97, ZIP FAST RIDER 50 2T 93-94, ZIP FAST RIDER RST 50 2T 96-97, ZIP RST 50 2T 96-99, ZIP SP 50 2T 96-00

RICAMBI

9909940	Chiavetta disassata
---------	---------------------



◀ cod. **9921790**
Centralina digitale ad anticipo variabile per motori scooter 50 cc Minarelli/Yamaha

APPLICABILITÀ

MBK BOOSTER EURO 2 50 2T 04-04, BOOSTER NG 50 2T 03-03, BOOSTER SPIRIT 50 2T 03-03, BOOSTER SPIRIT EURO2 50 2T 03-03, FLIPPER EURO 2 50 2T 03-03, MACH G 50 2T 02-04, MACH G LC 50 2T 02-04, NITRO EURO 2 50 2T 03-03, OVETTO EURO 2 50 2T 02-02

YAMAHA AEROX 50 2T 04-16, AEROX EURO 2 50 2T 03-03, AEROX NAKED 50 2T 13-16, BW'S 50 2T 04-16, BW'S EASY 50 2T 13-13, BW'S NAKED 50 2T 04-04, BW'S NAKED 50 2T 09-16, BW'S NEXT GENERATION 50 2T 03-06, JOG R EURO2 50 2T 02-02, JOG R EURO2 50 2T 06-15, JOG R LC 50 2T 02-15, NEO'S 50 2T 04-16, NEO'S EASY 50 2T 13-13, NEO'S EURO 2 50 2T 02-02, WHY EURO 2 50 2T 03-05



◀ cod. **9925780**
Centralina digitale ad anticipo variabile F12 EU2 dal '06

APPLICABILITÀ

MALAGUTI CIAK MASTER EURO 2 50 2T 06-06, F10 RESTYLING EURO 2 50 2T 06-06, F12 R PHANTOM LC 50 2T 07-10, F12 RESTYLING EURO 2 50 2T 06-06, F12 RESTYLING LC EURO 2 50 2T 06-06, F15 FIRE FOX AIR COOLED 50 2T 05-06, F15 FIRE FOX EURO 2 50 2T 04-06



◀ cod. **9926150**
Centralina digitale ad anticipo variabile per Piaggio 50 4T

APPLICABILITÀ

PIAGGIO FLY 4T 50 4T 05-07, FLY 4T & 25-30 KM/H 50 4T 08-11, FLY 4T MOTORE CHN 50 4T 06-07, LIBERTY 4T 50 4T 00-02, LIBERTY 4T 50 4T 05-08, LIBERTY 4T DELIVERY - SINGLE 50 4T 10-14, LIBERTY 4T DELIVERY TNT 50 4T 09-09, LIBERTY 4T PTT - DOUBLE - NEXIVE 50 4T 09-17, LIBERTY 4T RST 50 4T 04-04, LIBERTY 4T SPORT 50 4T 06-08, LIBERTY MOC 4T & ELLE 50 4T 09-16, VESPA ET4 50 4T 00-05, VESPA LX 4T 50 4T 05-09, ZIP 4T 50 4T 00-13



◀ cod. **9934440**
Centralina digitale "TPR" per AM6 EU4

APPLICABILITÀ

BETA RR 2T 50 EU4 50 2T 18-20, RR 50 RACING EU4 50 2T 18-20
FANTIC ENDURO COMPETITION EU4 50 2T 18-20, ENDURO PERFORMANCE EU4 50 2T 18-20, MOTARD COMPETITION EU4 50 2T 18-20, MOTARD PERFORMANCE EU4 50 2T 18-20
RIEJU MRT 50 EU4 50 2T 18-20, MRT PRO EU4 50 2T 18-20, MRT PRO REPLICA EU4 50 2T 18-20, MRT PRO REPLICA SM EU4 50 2T 18-20, MRT PRO SM EU4 50 2T 18-20, MRT SM EU4 50 2T 18-20, MRT TROPHY EU4 50 2T 18-20, RS3 EU4 50 2T 18-20, RS3 NKD EU4 50 2T 18-20

SHERCO FACTORY SE-R EU4 50 2T 18-20, FACTORY SE-RS EU4 50 2T 18-20, FACTORY SILVER SM-R EU4 50 2T 18-20, FACTORY SILVER SM-RS EU4 50 2T 18-20, FACTORY SM-R EU4 50 2T 18-20, FACTORY SM-RS EU4 50 2T 18-20

VENT BAJA 50 2T 18-20, BAJA RR 50 2T 18-20, DERAPAGE 50 2T 18-20, DERAPAGE RR 50 2T 18-20

RICAMBI

9934460	MAP SWITCH
---------	------------



◀ cod. **9922900**
Cappuccio candela con resistore

ALBERI A CAMME



◀ **cod. 9927230**
Kit albero a camme per motori Minarelli/Yamaha 125 4v

APPLICABILITÀ

BETA	RR 125 4T-4V 10-17	MOTOR	KN1 125 4T-4V 08-08, MH7 125 4T-4V 08-08, RX-R 125 4T-4V 08-08
FANTIC	CABALLERO MOTARD 125 4T-4V 08-18, CABALLERO REGOLARITÀ 125 4T-4V 08-08	HISPANIA	
HM	CITY 125 4T-4V 11-13, CRE F125X 125 4T-4V 08-09, CRE F125X BAJA 125 4T-4V 10-12, CRE F125X BAJA RR 125 4T-4V 10-12, CRE F125X SIX 125 4T-4V 10-11, CRM F125X 125 4T-4V 08-09, CRM F125X DERAPAGE 125 4T-4V 10-11, CRM F125X DERAPAGE RR 125 4T-4V 10-12, LOCUSTA 125 4T-4V 11-13, CITY 200 4T-4V 11-13, LOCUSTA 200 4T-4V 11-13	RIEJU	MARATHON 125 4T-4V 09-09, MARATHON PRO 125 4T-4V 09-09, MARATHON PRO COMPETITION 125 4T-4V 11-11, RS3 125 4T-4V 11-11
HUSQVARNA	SM 125 4T-4V 10-10, TE 125 4T-4V 10-10	VENT	BAJA 125 4T-4V 18-19, BAJA RR 125 4T-4V 18-19, DERAPAGE 125 4T-4V 18-19, DERAPAGE RR 125 4T-4V 18-19, TRAIL 125 4T-4V 18-19
MBK	CITYLINER EU3 125 4T-4V 08-10, SKYCRUISER 125 4T-4V 07-07	YAMAHA	MT 125 4T 4V IE 15-15, MT A 125 4T 4V IE 15-15, WR-R IE 125 4T 4V IE 09-11, WR-X IE 125 4T 4V IE 09-11, WR-X IE 125 4T 4V IE 13-14, X-CITY EU3 125 4T-4V 08-11, X-MAX R 125 4T-4V 06-16, X-MAX R ABS 125 4T-4V 11-11, X-MAX RA ABS 125 4T-4V 13-16, YZF-R A IE 125 4T 4V IE 15-15, YZF-R IE 125 4T 4V IE 08-15

◀ **cod. 9928160**
Albero a camme Yamaha YZF 125 R con kit 183 cc

APPLICABILITÀ

Yamaha YZF-R IE 125 4T 4V IE 08-13

RICAMBI

9928130	REGOLATORE PRESSIONE 3.5 BAR
---------	------------------------------

CAMBIO COMPLETO



◀ **cod. 9935000**
Cambio completo AM6

RACING

APPLICABILITÀ

APRILIA	CLASSIC 50 2T 92-99, MX 50 2T 04-04, MX MOTARD 50 2T 95-03, RS 50 2T 93-05, RX 50 2T 03-04, RX ENDURO 50 2T 95-03, TUONO 50 2T 03-04	MOTOR	FURIA 50 2T 97-00, FURIA MAX 50 2T 10-12, RX 50 2T 09-12, RX R 50 2T 09-12
BETA	RR 2T 50 EU4 50 2T 18-20, RR 50 RACING EU4 50 2T 18-20, RR ALU 50 2T 08-12, RR ENDURO 50 2T 06-17, RR MOTARD 50 2T 06-17	HISPANIA	
CH HUSQVARNA	SM 50 2T 00-10, WR 50 2T 00-10, WSM 50 2T 00-10	PEUGEOT	SUPERMOTARD 50 2T 90-02, XP6 TRAIL S/AVV. ELETTRICO 50 2T 90-02, XR6 RACING CAT. C/AVV.ELETT. 50 2T 90-02
CMC	ENDURO 50 2T 11-11, MOTARD 50 2T 11-11	RIEJU	MRT 50 2T 09-12, MRT 50 EU4 50 2T 18-20, MRT PRO 50 2T 09-12, MRT PRO EU4 50 2T 18-20, MRT PRO REPLICA EU4 50 2T 18-20, MRT PRO REPLICA SM EU4 50 2T 18-20, MRT PRO SM 50 2T 09-12, MRT SM EU4 50 2T 18-20, MRT TROPHY EU4 50 2T 18-20, MRX 50 2T 01-04, MRX PRO 50 2T 01-04, RR 50 2T 05-06, RS1 50 2T 98-01, RS2 MATRIX 50 2T 05-06, RS2 MATRIX PRO 50 2T 05-06, RS2 NAKED 50 2T 04-05, RS3 EU4 50 2T 18-20, RS3 NKD EU4 50 2T 18-20, SMX E.S./K.S. 50 2T 01-01, SMX PRO E.S./K.S. 50 2T 03-03, SPIKE 50 2T 98-01
FANTIC	CABALLERO MOTARD 50 2T 06-10, CABALLERO REGOLARITÀ 50 2T 06-10, ENDURO COMPETITION EU4 50 2T 18-20, ENDURO PERFORMANCE EU4 50 2T 18-20, MOTARD COMPETITION EU4 50 2T 18-20, MOTARD PERFORMANCE EU4 50 2T 18-20	SHERCO	FACTORY SE-R EU4 50 2T 18-20, FACTORY SE-RS EU4 50 2T 18-20, FACTORY SILVER SM-R EU4 50 2T 18-20, FACTORY SILVER SM-RS EU4 50 2T 18-20, FACTORY SM-R EU4 50 2T 18-20, FACTORY SM-RS EU4 50 2T 18-20, HRD ENDURO 50 2T 09-13, HRD MOTARD 50 2T 09-13
HM	BAJA, DERAPAGE BASIC 50 2T 10-11, CMC 50 2T 10-11, CRE BAJA RR, DERAPAGE RR 50 2T 07-11, CRE BAJA, DERAPAGE 50 2T 07-11, CRE SIX COMPETITION 50 2T 10-11, CRE SIX, BAJA, DERAPAGE 50 2T 95-06, CRE SIX, DERAPAGE COMPETITION 50 2T 07-09, DERAPAGE COMPETITION 50 2T 10-11	VENT	BAJA 50 2T 18-20, BAJA RR 50 2T 18-20, DERAPAGE 50 2T 18-20, DERAPAGE RR 50 2T 18-20
MALAGUTI	CNK DRAGON 50 2T 05-07, XSM 50 2T 03-03, XTM 50 2T 03-03	YAMAHA	DT R 50 2T 03-11, DT RSM 50 2T 03-05, DT X 50 2T 06-11, TZR 50 2T 03-08, TZR 50 2T 10-10, TZR RR 50 2T 05-05
MBK	X LIMIT 50 2T 03-04, X POWER 50 2T 03-04		
MINARELLI	MOTORE AM 6 1° SERIE 50 2T 96-11, MOTORE AM 6 2° SERIE 50 2T 12-18		

DESMODROMICO CAMBIO



◀ **cod. 9920020**

RACING

Desmodromico cambio in "ERGA 55" per motori Minarelli AM6

APPLICABILITÀ

APRILIA	CLASSIC 50 2T 92-99, MX 50 2T 04-04, RS 50 2T 93-05, RX 50 2T 03-04, TUONO 50 2T 03-04	MOTOR	FURIA 50 2T 97-00, FURIA MAX 50 2T 10-12, RX 50 2T 09-12, RX R 50 2T 09-12
BETA	RR 2T 50 EU4 50 2T 18-20, RR 50 RACING EU4 50 2T 18-20, RR ALU 50 2T 08-12, RR ENDURO 50 2T 06-17, RR MOTARD 50 2T 06-17	HISPANIA	
CH HUSQVARNA	SM 50 2T 00-10, WR 50 2T 00-10, WSM 50 2T 00-10	PEUGEOT	SUPERMOTARD 50 2T 90-02, XP6 TRAIL S/AVV. ELETTRICO 50 2T 90-02, XR6 RACING CAT. C/AVV.ELETT. 50 2T 90-02
CMC	ENDURO 50 2T 11-11, MOTARD 50 2T 11-11	RIEJU	MRT 50 2T 09-12, MRT 50 EU4 50 2T 18-20, MRT PRO 50 2T 09-12, MRT PRO EU4 50 2T 18-20, MRT PRO REPLICA EU4 50 2T 18-20, MRT PRO REPLICA SM EU4 50 2T 18-20, MRT PRO SM 50 2T 09-12, MRT SM EU4 50 2T 18-20, MRT TROPHY EU4 50 2T 18-20, MRX 50 2T 01-04, MRX PRO 50 2T 01-04, RR 50 2T 05-06, RS1 50 2T 98-01, RS2 MATRIX 50 2T 05-06, RS2 MATRIX PRO 50 2T 05-06, RS2 NAKED 50 2T 04-05, RS3 EU4 50 2T 18-20, RS3 NKD EU4 50 2T 18-20, SMX E.S./K.S. 50 2T 01-01, SMX PRO E.S./K.S. 50 2T 03-03, SPIKE 50 2T 98-01
FANTIC	CABALLERO MOTARD 50 2T 06-10, CABALLERO REGOLARITÀ 50 2T 06-10, ENDURO COMPETITION EU4 50 2T 18-20, ENDURO PERFORMANCE EU4 50 2T 18-20, MOTARD COMPETITION EU4 50 2T 18-20, MOTARD PERFORMANCE EU4 50 2T 18-20	SHERCO	FACTORY SE-R EU4 50 2T 18-20, FACTORY SE-RS EU4 50 2T 18-20, FACTORY SILVER SM-R EU4 50 2T 18-20, FACTORY SILVER SM-RS EU4 50 2T 18-20, FACTORY SM-R EU4 50 2T 18-20, FACTORY SM-RS EU4 50 2T 18-20, HRD ENDURO 50 2T 09-13, HRD MOTARD 50 2T 09-13
HM	BAJA, DERAPAGE BASIC 50 2T 10-11, CMC 50 2T 10-11, CRE BAJA RR, DERAPAGE RR 50 2T 07-11, CRE BAJA, DERAPAGE 50 2T 07-11, CRE SIX COMPETITION 50 2T 10-11, CRE SIX, BAJA, DERAPAGE 50 2T 95-06, CRE SIX, DERAPAGE COMPETITION 50 2T 07-09, DERAPAGE COMPETITION 50 2T 10-11	VENT	BAJA 50 2T 18-20, BAJA RR 50 2T 18-20, DERAPAGE 50 2T 18-20, DERAPAGE RR 50 2T 18-20
MALAGUTI	CNK DRAGON 50 2T 05-07, XSM 50 2T 03-03, XTM 50 2T 03-03	YAMAHA	DT R 50 2T 03-11, DT RSM 50 2T 03-05, DT X 50 2T 06-11, TZR 50 2T 03-08, TZR 50 2T 10-11, TZR RR 50 2T 05-05
MBK	X LIMIT 50 2T 03-04, X POWER 50 2T 03-04		
MINARELLI	MOTORE AM 6 1° SERIE 50 2T 96-11, MOTORE AM 6 2° SERIE 50 2T 12-18		

ATTENZIONE: QUESTI PRODOTTI SONO DESTINATI ESCLUSIVAMENTE AD USO AGONISTICO. NE È QUINDI VIETATO L'UTILIZZO SU STRADA PUBBLICA.



◀ **cod. 9921280**
Albero motore competizione corsa 40,2 mm con ralle
Per motore scooter 50 cc Minarelli/Yamaha tipo orizzontale A.C. e L.C.

RICAMBI

9914540	Gabbia a rulli	9921410	Biella completa
---------	----------------	---------	-----------------



◀ **cod. 9921720** **RACING**
Albero motore corsa 39 mm a piattelli pieni per motori Minarelli AM6

APPLICABILITÀ

APRILIA	CLASSIC 50 2T 92-99, EUROPA 50 2T 91-92, MX 50 2T 04-04, MX MOTARD 50 2T 95-03, PEGASO 50 2T 92-94, RS 50 2T 91-05, RX 50 2T 03-04, RX 3-5 MARCE 50 2T 91-94, RX ENDURO 50 2T 95-03, RX RACING 50 2T 03-06, TUONO 50 2T 03-04	MINARELLI	MOTORE AM 3-4-5 50 2T 91-95, MOTORE AM 6 1° SERIE 50 2T 96-11, MOTORE AM 6 2° SERIE 50 2T 12-18
BETA	RR 2T 50 EU4 50 2T 18-20, RR 50 RACING EU4 50 2T 18-20, RR ALU 50 2T 08-12, RR ENDURO 50 2T 06-17, RR MOTARD 50 2T 06-17	MOTOR HISPANIA	FURIA 50 2T 97-00, FURIA MAX 50 2T 10-12, RX 50 2T 09-12, RX R 50 2T 09-12
CH HUSQUARNA	SM 50 2T 00-10, WR 50 2T 00-10, WSM 50 2T 00-10	PEUGEOT	SUPERMOTARD 50 2T 90-02, XP6 TRAIL S/AVV. ELETTRICO 50 2T 90-02, XR6 RACING CAT. C/AVV.ELETT. 50 2T 90-02
CMC	ENDURO 50 2T 11-11, MOTARD 50 2T 11-11	RIEJU	MRT 50 2T 09-12, MRT 50 EU4 50 2T 18-20, MRT PRO 50 2T 09-12, MRT PRO EU4 50 2T 18-20, MRT PRO REPLICA EU4 50 2T 18-20, MRT PRO REPLICA SM EU4 50 2T 18-20, MRT PRO SM 50 2T 09-12, MRT PRO SM EU4 50 2T 18-20, MRT SM 50 2T 09-12, MRT SM EU4 50 2T 18-20, MRT TROPHY EU4 50 2T 18-20, MRX 50 2T 01-04, MRX PRO 50 2T 01-04, RR 50 2T 05-06, RS1 50 2T 98-01, RS2 MATRIX 50 2T 05-06, RS2 MATRIX PRO 50 2T 05-06, RS2 NAKED 50 2T 04-05, RS3 EU4 50 2T 18-20, RS3 NKD EU4 50 2T 18-20, SMX E.S./K.S. 50 2T 01-01, SMX PRO E.S./K.S. 50 2T 03-03, SPIKE 50 2T 98-01
FANTIC	CABALLERO MOTARD 50 2T 06-10, CABALLERO REGOLARITÀ 50 2T 06-10, ENDURO COMPETITION EU4 50 2T 18-20, ENDURO PERFORMANCE EU4 50 2T 18-20, MOTARD COMPETITION EU4 50 2T 18-20, MOTARD PERFORMANCE EU4 50 2T 18-20	SHERCO	FACTORY SE-R EU4 50 2T 18-20, FACTORY SE-RS EU4 50 2T 18-20, FACTORY SILVER SM-R EU4 50 2T 18-20, FACTORY SILVER SM-RS EU4 50 2T 18-20, FACTORY SM-R EU4 50 2T 18-20, FACTORY SM-RS EU4 50 2T 18-20, HRD ENDURO 50 2T 09-13, HRD MOTARD 50 2T 09-13
HM	BAJA, DERAPAGE BASIC 50 2T 10-11, CMC 50 2T 10-11, CRE BAJA RR, DERAPAGE RR 50 2T 07-11, CRE BAJA, DERAPAGE 50 2T 07-11, CRE SIX COMPETITION 50 2T 10-11, CRE SIX, BAIA, DERAPAGE 50 2T 95-06, CRE SIX, DERAPAGE COMPETITION 50 2T 07-09, DERAPAGE COMPETITION 50 2T 10-11	VENT	BAJA 50 2T 18-20, BAJA RR 50 2T 18-20, DERAPAGE 50 2T 18-20, DERAPAGE RR 50 2T 18-20
MALAGUTI	CNK DRAGON 50 2T 05-07, FIFTY EVOLUTION 50 2T 90-93, XSM 50 2T 03-03, XTM 50 2T 03-03	YAMAHA	DT R 50 2T 03-11, DT RSM 50 2T 03-05, DT X 50 2T 06-11, TZR 50 2T 03-08, TZR 50 2T 10-11, TZR RR 50 2T 05-05
MBK	X LIMIT 50 2T 03-04, X POWER 50 2T 03-04		

RICAMBI

9924750	Kit cuscinetti paraoli banco	IM07036	Biella
9921330	Gabbia a rulli		



◀ **cod. 9925910** **RACING**
Albero motore completo "TPR" corsa 39,2 spinotto Ø 10 per motore scooter 50 cc Minarelli/Yamaha tipo orizzontale con cuscinetti

RICAMBI

9914540	Gabbia a rulli	9925920	Biella spinotto Ø 10
KK01002	Kit cuscinetti e paraoli		



◀ **cod. 9926180** **RACING**
Albero motore completo "TPR" corsa 39,3 spinotto Ø 12
Per motore scooter 50 cc Piaggio/Gilera con cuscinetti

RICAMBI

9907820	Gabbia a rulli	9926190	Biella spinotto Ø 12
KK01009	Kit cuscinetti e paraoli		



◀ cod. **9927900** **RACING**

Albero motore completo "TPR" corsa 39,2 spinotto Ø 10 per motore scooter 50 cc Minarelli/Yamaha tipo verticale con cuscinetti

RICAMBI

9914540	Gabbia a rulli
KK01002	Kit cuscinetti paraoli

9925920	Biella spinotto Ø 10
---------	----------------------



◀ cod. **9928320** **RACING**

Albero motore completo "TPR" corsa 39,2 spinotto Ø 12 per motore scooter 50 cc Minarelli/Yamaha tipo orizzontale con cuscinetti

RICAMBI

9907820	Gabbia a rulli
KK01002	Kit cuscinetti paraoli

9929490	Biella spinotto Ø 12
---------	----------------------



◀ cod. **9930150** **RACING**

Albero motore "TPR" corsa std per Derbi (d50b0) + cuscinetti e paraoli

APPLICABILITÀ

APRILIA RS 50 2T 06-10, RS4 50 2T 11-13, RS4 REPLICA 50 2T 14-16, RX 50 2T 06-10, RX 50 2T 14-16, SX 50 2T 06-16, SX LIMITED EDITION 50 2T 14-16

DERBI GPR 2T 50 2T 13-13, GPR 2T EU2 50 2T 09-10, GPR NUDE & GPR NUDE TUNING 50 2T 06-08, GPR NUDE SPORT 50 2T 06-06, GPR R EU2 - GPR REPLICA EU2 50 2T 08-08, GPR RACING EU2 50 2T 06-06, GPR REPLICA & GPR R EU2 50 2T 06-06, GPR REPLICA 2T MALOSSÌ 50 2T 07-07, GPR REPLICA PESEK EU2 50 2T 07-07, SENDA HYP DRD EVO EU2 50 2T 08-09, SENDA HYP DRD EVO LIMITED EDITION EU2 50 2T 08-08, SENDA R DRD PRO EU2 50 2T 05-11, SENDA R DRD RACING EU2 50 2T 05-08, SENDA R DRD X-TREME 2T EU2 50 2T 14-15, SENDA R DRD X-TREME 2T EURO2 50 2T 10-12, SENDA R X-RACE 2T EU2 50 2T 10-10, SENDA R X-RACE EU2 50 2T 06-09, SENDA R X-TREME 2T EU2 50 2T 10-10, SENDA R X-TREME EU2 50 2T 05-08, SENDA SM DRD PRO EU2 50 2T 05-11, SENDA SM DRD PRO EU2 2VER 50 2T 05-08, SENDA SM DRD RACING EU2 50 2T 05-08, SENDA SM DRD RACING EU2 50 2T 10-13, SENDA SM DRD RACING LTD EU2 50 2T 07-07, SENDA SM DRD X-TREME 2T EU2 50 2T 14-15, SENDA SM DRD X-TREME 2T EU2 LIMITED ED 50 2T 14-15, SENDA SM X-RACE 2T EU2 50 2T 10-10, SENDA SM X-RACE EU2 50 2T 06-09, SENDA SM X-RACE EU2 2VER 50 2T 07-09, SENDA SM X-TREME 2T EU2 50 2T 10-10, SENDA SM X-TREME EU2 50 2T 05-08

GILERA RCR 50 2T 06-07, RCR 50 2T 11-12, RCR (CHE-SYC) 50 2T 13-15, SMT 50 2T 06-17, SMT RACING 50 2T 11-12

VALENTI RACING RME 50 2T 15-17, SM 50 2T 15-17

RICAMBI

AA00766	Gabbia su spinotto d.12X15x15 AM6-Derbi
KK01008	Kit cuscin/paraoli banco Derbi plurimarc



◀ **cod. 9924940** **RACING**
Campane frizione "TPR" Ø 107 per motore scooter 50 cc Minarelli/Yamaha orizzontale

APPLICABILITÀ

- APRILIA** AREA 51 50 2T 98-00, GULLIVER 50 2T 95-98, GULLIVER LC 50 2T 96-98, RALLY 50 2T 95-03, RALLY LIQUID COOLED 50 2T 96-99, SCARABEO 50 2T 93-05, SONIC 50 2T 98-07, SONIC GP 50 2T 98-08, SR (ORIZZONTALE) 50 2T 94-96, SR LIQUID COOLED 50 2T 94-96, SR RACING 50 2T 97-99, SR STEALTH 50 2T 97-00, SR WWW 50 2T 97-01
- ATALA** CAROSELLO 50 2T 99-01
- BENELLI** 491 GT 50 2T 98-99, 491 NAKED 50 2T 02-02, 491 RACING 50 2T 98-99, 491 RR 50 2T 99-01, 491 SP 50 2T 99-99, 491 SPORT 50 2T 98-99, 491 ST 50 2T 99-01, K2 50 2T 98-01, K2 LIQUID COOLED 50 2T 98-01, PEPE 50 2T 99-01, PEPE LX 50 2T 03-04
- BETA** ARK 50 2T 96-08, ARK LC 50 2T 96-08, CHRONO 50 2T 95-96, EIKON 50 2T 99-03, QUADRA 50 2T 95-95, QUADRA 50 2T 99-01, TEMPO 50 2T 93-02, TEMPO 50 2T 95-95
- ITALJET** DRAGSTER 50 2T 98-02
- KTM** K50 50 2T 96-01
- MACAL** THUNDER 50 2T 95-96

- MALAGUTI** CENTRO SL 50 2T 94-98, CIAK 50 2T 99-01, CIAK EURO 2 2,3 50 2T 03-03, CIAK EURO2 50 2T 01-03, CIAK MASTER EURO 2 50 2T 06-06, F10 50 2T 92-00, F10 EURO 2 50 2T 02-06, F10 EURO 2,2,3 50 2T 03-04, F10 RESTYLING EURO 2 50 2T 06-06, F12 PHANTOM 50 2T 94-98, F12 PHANTOM EURO 2,2,3 50 2T 03-04, F12 PHANTOM LC 50 2T 94-98, F12 R PHANTOM LC 50 2T 07-10, F12 RESTYLING EURO 2 50 2T 06-06, F15 FIRE FOX 50 2T 96-98, F15 FIRE FOX AIR COOLED 50 2T 05-06, F15 FIRE FOX EURO 2 50 2T 02-06, F15 FIRE FOX EURO 2,2,3 50 2T 03-04, YESTERDAY 50 2T 97-00
- MBK** EVOLIS 50 2T 92-95, FIZZ 50 2T 94-95, FLIPPER 50 2T 98-04, FLIPPER EURO 2 50 2T 03-03, FORTE 50 2T 94-96, MACH G 50 2T 02-04, MACH G LC 50 2T 02-04, NITRO 50 2T 97-04, NITRO EURO 2 50 2T 03-03, OVETTO 50 2T 97-04, OVETTO EURO 2 50 2T 02-02
- MOTRON** SYNCRO 50 2T 98-00, THUNDER 50 2T 95-98
- RIEJU** FIRST 50 2T 95-98, WINDY 50 2T 95-98
- YAMAHA** AEROX 50 2T 97-02, AEROX 50 2T 04-16, AEROX EURO 2 50 2T 03-03, AEROX NAKED 50 2T 13-16, AEROX R 50 2T 99-00, AEROX R 50 2T 99-99, AXIS 50 2T 95-96, BREEZE 50 2T 94-95, JOG 50 2T 92-01, JOG R 50 2T 02-02, JOG R EURO2 50 2T 02-02, JOG R EURO2 50 2T 06-15, JOG R LC 50 2T 02-15, NEO'S 50 2T 97-02, NEO'S 50 2T 04-16, NEO'S EASY 50 2T 13-13, NEO'S EURO 2 50 2T 02-02, WHY 50 2T 98-05, WHY EURO 2 50 2T 03-05



◀ **cod. 9924950** **RACING**
Campane frizione "TPR" Ø 107 scooter 50 cc Piaggio

APPLICABILITÀ

- APRILIA** MOJITO CUSTOM 2T MOTORE PIAGGIO 50 2T 04-10, SCARABEO 2T EU2 MOTORE PIAGGIO 50 2T 10-12, SCARABEO 2T NET 50 2T 09-10, SCARABEO 4T 50 4T 02-06, SCARABEO 4T 4V 50 4T 4V 10-12, SCARABEO 4T 4V NET 50 4T 4V 09-10, SCARABEO 4T RESTYLING EU3 50 4T 06-09, SCARABEO QUATTRO 50 4T 4V 09-09, SCARABEO STREET 50 2T 05-06, SCARABEO STREET 2T RESTYLING 50 2T 06-09, SPORT CITY ONE 2T 50 2T 08-11, SPORT CITY ONE 4T 50 4T 08-10, SR MOTARD 50 2T 12-14, SR R 50 2T 04-09, SR R FACTORY CARBURATORE 50 2T 10-14, SR R FACTORY IE 50 2T 10-14, SR STREET CARBURATORE 50 2T 03-12
- DERBI** ATLANTIS 2T 50 2T 10-10, ATLANTIS 2T EU 50 2T 07-09, ATLANTIS O2 50 2T 02-02, ATLANTIS O2 BULLET 50 2T 03-05, ATLANTIS O2 CITY 50 2T 04-06, ATLANTIS O2 RED BULLET 50 2T 03-03, ATLANTIS O2 TWO CHIC 50 2T 05-05, BOULEVARD 2T 50 2T 09-14, GP1 50 2T 01-03, GP1 EU 2 50 2T 05-05, GP1 OPEN EU 2 50 2T 06-09, GP1 RACE EU 2 50 2T 05-07, SONAR 2T 50 2T 09-09
- GILERA** DNA 50 2T 00-02, DNA 50 2T 05-07, DNA GP EXPERIENCE 50 2T 03-04, EASY MOVING 50 2T 95-96, ICE 50 2T 01-05, RUNNER 50 2T 97-00, RUNNER POGGIALI 50 2T 02-02, RUNNER PURE JET 50 2T-IE 02-07, RUNNER PURE JET 50 2T-IE 10-11, RUNNER PURE JET ST 50 2T-IE 08-08, RUNNER SP 50 2T 02-07, RUNNER SP 50 2T 10-12, RUNNER SP SPECIAL EDITION 50 2T 07-07, RUNNER SP ST & SIMONCELLI 50 2T 08-09, STALKER 50 2T 97-11, STALKER NAKED 50 2T 08-08, STALKER SPECIAL EDITION 50 2T 07-08, STORM 50 2T 94-95, STORM EURO 2 50 2T 07-07, TYPHOON 50 2T 94-97, TYPHOON X 50 2T 98-99, TYPHOON XR 50 2T 00-00

- ITALJET** JET SET 50 2T 02-02, TORPEDO NEW 50 2T 00-01
- PIAGGIO** DIESIS 50 2T 01-01, FLY 2T 50 2T 05-07, FLY 2T 50 2T 10-11, FREE 50 2T 92-94, FREE DELIVERY 50 2T 00-01, FREE FL 50 2T 95-02, LIBERTY 50 2T 97-05, LIBERTY 2T 50 2T 06-08, LIBERTY 2T PTT EU 2 50 2T 04-05, LIBERTY 2T RST 50 2T 04-04, LIBERTY 2T SPORT 50 2T 06-08, LIBERTY 4T 3V IE 50 4T 3V 15-17, LIBERTY 4T 3V IE E4 50 4T 3V 17-18, LIBERTY MOC 2T & ELLE 50 2T 09-13, NRG 50 2T 94-96, NRG EXTREME LC 50 2T 99-00, NRG MC3 50 2T 01-04, NRG POWER DD 50 2T 05-17, NRG POWER DD SERIE SPECIALE 50 2T 07-12, NRG POWER DT 50 2T 06-15, NRG POWER DT SERIE SPECIALE 50 2T 07-08, NRG POWER PUREJET 50 2T-IE 04-11, NRG PUREJET 50 2T-IE 02-04, NRG PUREJET 50 2T-IE 10-10, NRG RST MC2 50 2T 96-98, NIT 50 2T 95-96, QUARTZ 50 2T 92-96, SFERA 50 2T 91-93, SFERA MAQUILLAGE 2 50 2T 94-94, SFERA RST 50 2T 95-97, TYPHOON 50 2T 01-11, TYPHOON 2T E2 50 2T 10-12, TYPHOON 2T E3 CH 50 2T 11-11, VESPA ET2 50 2T 97-05, VESPA ET2 INIEZIONE 50 2T 97-00, VESPA LX 2T 50 2T 05-13, VESPA LX 2T TOURING & 30KM 50 2T 10-13, VESPA LXV 2T 50 2T 06-09, VESPA LXV 2T NAVY 50 2T 08-08, VESPA S 2T & COLLEGE 50 2T 07-12, ZIP 50 2T 92-93, ZIP 50 2T 95-96, ZIP 2T 50 2T 08-13, ZIP BIMODALE 50 2T 94-97, ZIP FAST RIDER 50 2T 93-94, ZIP FAST RIDER RST 50 2T 96-97, ZIP LC 50 2T 00-04, ZIP RST 50 2T 96-99, ZIP SP 50 2T 96-04, ZIP SP EURO 2 50 2T 06-13



◀ **cod. 9938000** **RACING**
Campana frizione AM con ribattini
A RICAMBIO PER

9918550 Coppia frizione denti dritti Z=68

APPLICABILITÀ

- APRILIA** CLASSIC 50 2T 92-99, EUROPA 50 2T 91-92, MX 50 2T 04-04, MX MOTARD 50 2T 95-03, PEGASO 50 2T 92-94, RS 50 2T 91-92, RS 50 2T 96-05, RX 50 2T 03-04, RX 3-5 MARCE 50 2T 91-94, RX ENDURO 50 2T 95-03, RX RACING 50 2T 03-06, TUONO 50 2T 03-04
- BETA** RR 2T 50 EU4 50 2T 18-20, RR 50 RACING EU4 50 2T 18-20, RR ALU 50 2T 08-12, RR ENDURO 50 2T 06-17, RR MOTARD 50 2T 06-17
- CH HU-SQUARNA** SM 50 2T 00-10, WR 50 2T 00-10, WSM 50 2T 00-10
- CMC** ENDURO 50 2T 11-11, MOTARD 50 2T 11-11
- FANTIC** CABALLERO MOTARD 50 2T 06-10, CABALLERO MOTARD COMPETITION 50 2T 06-10, CABALLERO REGOLARITÀ 50 2T 06-10, CABALLERO REGOLARITÀ COMPETITION 50 2T 06-10, ENDURO COMPETITION EU4 50 2T 18-20, ENDURO PERFORMANCE EU4 50 2T 18-20, MOTARD COMPETITION EU4 50 2T 18-20, MOTARD PERFORMANCE EU4 50 2T 18-20

- HM** BAJA, DERAPAGE BASIC 50 2T 10-11, CMC 50 2T 10-11, CRE BAJA RR, DERAPAGE RR 50 2T 07-11, CRE BAJA, DERAPAGE 50 2T 07-11, CRE SIX COMPETITION 50 2T 10-11, CRE SIX, BAJA, DERAPAGE 50 2T 95-06, CRE SIX, DERAPAGE COMPETITION 50 2T 07-09, DERAPAGE COMPETITION 50 2T 10-11
- MALAGUTI** CNK DRAGON 50 2T 05-07, FIFTY EVOLUTION 50 2T 90-93, XSM 50 2T 03-06, XSM POWER-UP 50 2T 07-10, XTM 50 2T 03-03, XTM 50 2T 06-06, XTM POWER-UP 50 2T 07-10
- MBK** X LIMIT 50 2T 03-04, X POWER 50 2T 03-04
- MINARELLI** MOTORE AM 3-4-5 50 2T 91-95, MOTORE AM 6 1° SERIE 50 2T 96-11, MOTORE AM 6 2° SERIE 50 2T 12-18
- MOTORHISPANIA** FURIA 50 2T 97-00, FURIA MAX 50 2T 10-12, RX 50 2T 09-12, RX R 50 2T 09-12
- PEUGEOT** SUPERMOTARD 50 2T 90-02, XP6 TRAIL S/AVV. ELETTRICO 50 2T 90-02, XR6 RACING CAT. C/AVV.ELETT. 50 2T 90-02

- RIEJU** MRT 50 2T 09-12, MRT 50 EU4 50 2T 18-20, MRT PRO 50 2T 09-12, MRT PRO EU4 50 2T 18-20, MRT PRO REPLICA EU4 50 2T 18-20, MRT PRO REPLICA SM EU4 50 2T 18-20, MRT PRO SM 50 2T 09-12, MRT PRO SM EU4 50 2T 18-20, MRT SM 50 2T 09-12, MRT SM EU4 50 2T 18-20, MRT TROPHY EU4 50 2T 18-20, MRX 50 2T 01-04, MRX PRO 50 2T 01-04, RR 50 2T 05-06, RS1 50 2T 98-01, RS2 MATRIX 50 2T 05-06, RS2 MATRIX PRO 50 2T 05-06, RS2 NAKED 50 2T 04-05, RS3 EU4 50 2T 18-20, RS3 NKD EU4 50 2T 18-20, SMX E.S./K.S. 50 2T 01-01, SMX PRO E.S./K.S. 50 2T 03-03, SPIKE 50 2T 98-01
- SHERCO** FACTORY SE-R EU4 50 2T 18-20, FACTORY SE-RS EU4 50 2T 18-20, FACTORY SILVER SM-R EU4 50 2T 18-20, FACTORY SILVER SM-RS EU4 50 2T 18-20, FACTORY SM-R EU4 50 2T 18-20, FACTORY SM-RS EU4 50 2T 18-20, HRD ENDURO 50 2T 09-13, HRD MOTARD 50 2T 09-13
- YAMAHA** DT R 50 2T 03-11, DT RSM 50 2T 03-05, DT X 50 2T 06-11, TZR 50 2T 03-08, TZR 50 2T 10-11, TZR RR 50 2T 05-05

CARICA BATTERIE



◀ cod. **9934160**
Professional Battery Charger



◀ cod. **9980060**
Carica batterie 12V per scooter

CARICATORI USB



◀ cod. **9980070**
Caricatore USB Presa Singola (2A - Cavo 0,5 m)



◀ cod. **9980080**
Caricatore USB Presa Doppia (5A - Cavo 3 m)

CONTAGIRI

NOVITÀ



◀ cod. **9937800**
Contagiri digitale con contaore - Alimentazione 12v

KIT DI PROGRAMMAZIONE



◀ cod. **9927340**
Kit programmazione centralina TFI
Per programmare le centraline iniezione. Consente la sostituzione delle mappe di iniezione all'interno delle centraline.

APPLICABILITÀ

MBK CITYLINER EU3 125 4T-4V 08-10, SKYCRUISER 125 4T-4V 07-07

YAMAHA WR-R IE 125 4T 4V IE 09-11, WR-X IE 125 4T 4V IE 09-11, WR-X IE 125 4T 4V IE 13-14, X-CITY EU3 125 4T-4V 08-11, X-MAX R 125 4T-4V 06-16, X-MAX R ABS 125 4T-4V 11-11, X-MAX RA ABS 125 4T-4V 13-16, YZF-R IE 125 4T 4V IE 08-13

SCOOTER 50 cc



◀ **cod. 9907770** 
Cinghia di trasmissione per motori scooter 50 cc Minarelli/Yamaha

RIFERIMENTO ORIGINALE

Aprilia	AP8206109
Benelli	R16140011A0

Yamaha	SRNE76411000
--------	--------------

APPLICABILITÀ: SCOOTER 50 CC

APRILIA AMICO 50 2T 94-94, AMICO 50 2T 96-98, AMICO GL/GLE 50 2T 93-95, AMICO LX/SPORT/CAT 50 2T 92-93, AREA 51 50 2T 98-00, GULLIVER 50 2T 95-98, GULLIVER LC 50 2T 96-98, RALLY 50 2T 95-03, RALLY LIQUID COOLED 50 2T 96-99, SCARABEO 50 2T 93-05, SR (ORIZZONTALE) 50 2T 94-96, SR (VERTICALE) 50 2T 93-93, SR LIQUID COOLED 50 2T 94-96, SR RACING 50 2T 97-99, SR STEALTH 50 2T 97-00, SR WWW 50 2T 97-01

ATALA CAROSELLO 50 2T 99-01

BENELLI 491 GT 50 2T 98-99, 491 NAKED 50 2T 02-02, 491 RACING 50 2T 98-99, 491 RR 50 2T 99-01, 491 SP 50 2T 99-99, 491 SPORT 50 2T 98-99, 491 ST 50 2T 99-01, K2 50 2T 98-01, K2 LIQUID COOLED 50 2T 98-01, PEPE 50 2T 99-01, PEPE LX 50 2T 03-04

BETA ARK 50 2T 96-08, ARK LC 50 2T 96-08, CHRONO 50 2T 95-96, EIKON 50 2T 99-03, QUADRA 50 2T 95-95, QUADRA 50 2T 99-01, TEMPO 50 2T 93-02, TEMPO 50 2T 95-95

ITALJET DRAGSTER 50 2T 98-02, PISTA 2 50 2T 97-98, SCOOOP 2 50 2T 96-98, YANKEE 50 2T 93-97

KTM K50 50 2T 96-01

MACAL THUNDER 50 2T 95-96

MALAGUTI CENTRO SL 50 2T 94-98, CIAK 50 2T 99-01, CIAK EURO 2 2,3 50 2T 03-03, CIAK EURO2 50 2T 01-03, CIAK MASTER EURO 2 50 2T 06-06, F12 PHANTOM 50 2T 94-98, F12 PHANTOM EURO 2 50 2T 02-02, F12 PHANTOM EURO 2 2,3 50 2T 03-04, F12 PHANTOM LC 50 2T 94-98, F12 PHANTOM LC EURO 2 2,3 50 2T 03-04, F12 R PHANTOM LC 50 2T 07-10, F12 RESTYLING EURO 1 50 2T 99-02, F12 RESTYLING EURO 2 50 2T 06-06, F12 RESTYLING LC EURO 2 50 2T 06-06, F15 FIRE FOX 50 2T 96-98, F15 FIRE FOX AIR COOLED 50 2T 05-06, F15 FIRE FOX EURO 2 50 2T 02-06, F15 FIRE FOX EURO 2,2,3 50 2T 03-04

MBK BOOSTER 50 2T 90-04, BOOSTER 50 2T 90-94, BOOSTER EURO 2 50 2T 04-04, BOOSTER NG 50 2T 95-03, BOOSTER ROCKET 50 2T 97-98, BOOSTER SPIRIT 50 2T 96-00, BOOSTER SPIRIT 50 2T 03-03, BOOSTER SPIRIT EURO2 50 2T 03-03, BOOSTER TRACK 50 2T 96-98, FLIPPER 50 2T 98-04, FLIPPER EURO 2 50 2T 03-03, MACH G 50 2T 02-04, MACH G LC 50 2T 02-04, NITRO 50 2T 97-04, NITRO EURO 2 50 2T 03-03, OVETTO 50 2T 97-04, OVETTO EURO 2 50 2T 02-02, STUNT 50 2T 00-02

MOTRON SYNCRO 50 2T 98-00, THUNDER 50 2T 95-98

RIEJU FIRST 50 2T 95-98, WINDY 50 2T 95-98

YAMAHA AEROX 50 2T 97-02, AEROX 50 2T 04-16, AEROX EURO 2 50 2T 03-03, AEROX NAKED 50 2T 13-16, AEROX R 50 2T 99-00, AEROX R 50 2T 99-99, BW'S 50 2T 97-16, BW'S BUMP 50 2T 97-98, BW'S EASY 50 2T 13-13, BW'S NAKED 50 2T 03-04, BW'S NAKED 50 2T 09-16, BW'S NEXT GENERATION 50 2T 97-00, BW'S NEXT GENERATION 50 2T 99-06, BW'S ORIGINAL 50 2T 99-00, BW'S ORIGINAL 50 2T 99-02, BW'S ORIGINAL EURO 2 50 2T 03-03, JOG R 50 2T 02-02, JOG R EURO2 50 2T 02-02, JOG R EURO2 50 2T 06-15, JOG R LC 50 2T 02-15, NEO'S 50 2T 97-02, NEO'S 50 2T 04-16, NEO'S EASY 50 2T 13-13, NEO'S EURO 2 50 2T 02-02, RS SPY 50 2T 95-98, SLIDER 50 2T 00-02, WHY 50 2T 98-05, WHY EURO 2 50 2T 03-05, ZUMA 50 2T 97-01

◀ **cod. 9907900** 
Cinghia di trasmissione per motori scooter 50 cc Minarelli/Yamaha tipo orizzontale corto

RIFERIMENTO ORIGINALE

Aprilia	AP8206818
---------	-----------

Yamaha	3WF176410000
--------	--------------

APPLICABILITÀ: SCOOTER 50 cc - ATV QUAD

APRILIA SONIC 50 2T 98-07, SONIC GP 50 2T 98-08

DINLI HELIX DL603 50 2T 07-13, HELIX DL603 90 50 2T 07-13, T-REX 50 2T 07-13

E-TON VIPER RXL 50 2T 06-06

LAVERDA QUASAR 50 2T 02-04

MALAGUTI F10 50 2T 92-00, F10 EURO 2 50 2T 02-06, F10 EURO 2 2,3 50 2T 03-04, F10 RESTYLING EURO 2 50 2T 06-06, YESTERDAY 50 2T 97-00

MBK EVOLIS 50 2T 92-95, FIZZ 50 2T 94-95, FORTE 50 2T 94-96

YAMAHA AXIS 50 2T 95-96, BREEZE 50 2T 94-95, CRZ 50 2T 91-95, JOG 50 2T 92-01, ZEST 50 2T 95-92

◀ **cod. 9910790** 
Cinghia di trasmissione per motori scooter 50 cc Peugeot

RIFERIMENTO ORIGINALE

Peugeot	729171
---------	--------

APPLICABILITÀ

PEUGEOT BUXY 50 2T 90-02, BUXY RS 50 2T 90-02, ELYSEO 50 2T 90-02, JET FORCE 50 2T 90-02, LUDIX 50 2T 90-02, SPEEDAKE 50 2T 90-02, SPEEDFIGHT 50 2T 97-04, SPEEDFIGHT LC 50 2T 97-04, SQUAB 50 2T 90-02, TREKKER 50 2T 90-02, VIVACITY 50 2T 90-02, X-FIGHT 50 2T 00-02

SCOOTER 50 cc



◀ cod. **9913280** ^{TOP}
-performance-
Cinghia di trasmissione per motori scooter 50 cc Piaggio

RIFERIMENTO ORIGINALE

Benelli	R030424102000
Garelli	GA06570
Garelli	GA02165
Gilera	430728

Keeway	24107B01F000
Malaguti	59015000
Piaggio	430728

APPLICABILITÀ: SCOOTER 50 cc - ATV QUAD

BENELLI PEPE 50 2T 10-10, PEPE LX 50 2T 07-09, PEPE OLD 50 2T 07-09, PEPE OLD 50 2T 11-11, QUATTRONEX 50 2T 08-11 CPI: ARAGON 50 2T 03-03, HUSSAR 50 2T 03-03, OLIVER 50 2T 03-03, POP CORN 50 2T 03-03

EXPLORER CRACKER 50 2T 03-03

GARELLI TIESE 2T 50 2T 08-08, VIP 50 4T 06-06

GILERA STORM 50 2T 94-95, TYPHOON 50 2T 94-97, TYPHOON X 50 2T 98-99

HUPPER MONTECARLO 30 50 2T 09-09

KEEWAY ATV EC2 50 2T 06-06, ATV OFF ROAD 50 2T 07-07, F-ACT 50 2T 07-08, FLASH 50 2T 07-08, FOCUS 50 2T 06-06, GOCCIA 50 2T 09-09, HURRICANE 50 2T 06-08, MATRIX 50 2T 06-08, PIXEL EURO 2 50 2T 09-12, RY8 50 2T 08-08

MALAGUTI F10 AC WAP 50 2T 08-08, F12 R PHANTOM AC 50 2T 07-08

PIAGGIO FREE 50 2T 92-94, FREE FL 50 2T 95-02, NRG 50 2T 94-96, NRG RST MC2 50 2T 96-98, NTT 50 2T 95-96

◀ cod. **9913350** ^{TOP}
-performance-
Cinghia di trasmissione per motori scooter 50 cc Piaggio

RIFERIMENTO ORIGINALE

Piaggio	431190
---------	--------

APPLICABILITÀ

GILERA EASY MOVING 50 2T 95-96

PIAGGIO QUARTZ 50 2T 92-96, SFERA RST 50 2T 95-97, ZIP 50 2T 95-96, ZIP BIMODALE 50 2T 94-97, ZIP FAST RIDER 50 2T 93-94, ZIP FAST RIDER RST 50 2T 96-97, ZIP RST 50 2T 96-99, ZIP SP 50 2T 96-00

◀ cod. **9913360** ^{TOP}
-performance-
Cinghia di trasmissione per motori scooter 50 cc Piaggio

RIFERIMENTO ORIGINALE

Piaggio	286175
---------	--------

APPLICABILITÀ

PIAGGIO SFERA 50 2T 91-93, ZIP 50 2T 92-93

◀ cod. **9920440** ^{TOP}
-performance-
Cinghia di trasmissione per motori scooter 50 cc Aprilia Ditech

RIFERIMENTO ORIGINALE

Aprilia	AP2MCA000014
---------	--------------

APPLICABILITÀ

APRILIA HABANA-MOJITO CUSTOM 50 2T 99-03, HABANA-MOJITO RETRO* 50 2T 99-03, SCARABEO DITECH 50 2T-IE 01-04, SR DITECH EU2 50 2T-IE 02-04, SR H2O DITECH 50 2T-IE 00-04, SR R FACTORY MOTORE APRILIA 50 2T-IE 05-05

Suzuki KATANA K1-K4 50 2T 01-04, KATANA V-Y 50 2T 97-00, ZIL-LION UX 50 2T 99-99

Sym SYMPHONY EURO 2 50 4T 09-09

SCOOTER 50 cc



◀ **cod. 9922030** 
Cinghia di trasmissione per motori scooter 50 cc Piaggio

RIFERIMENTO ORIGINALE

Piaggio	436864
---------	--------

APPLICABILITÀ

APRILIA	MOJITO CUSTOM 2T MOTORE PIAGGIO 50 2T 04-10, SR MOTARD 50 2T 12-14, SR R 50 2T 04-09, SR R FACTORY CARBURATORE 50 2T 10-14, SR R FACTORY IE 50 2T 10-14, SR STREET CARBURATORE 50 2T 03-12	GILERA	ICE 50 2T 01-05, RUNNER 50 2T 97-00, RUNNER PURE JET 50 2T-IE 02-04, RUNNER SP 50 2T 02-06, STALKER 50 2T 97-11, STALKER NAKED 50 2T 08-08, STALKER SPECIAL EDITION 50 2T 07-08, STORM EURO 2 50 2T 07-07, TYPHOON XR 50 2T 00-00
DERBI	ATLANTIS 2T 50 2T 10-10, ATLANTIS 2T EU2 50 2T 07-09, ATLANTIS O2 50 2T 02-02, ATLANTIS O2 BULLET 50 2T 03-05, ATLANTIS O2 CITY 50 2T 04-06, ATLANTIS O2 RED BULLET 50 2T 03-03, ATLANTIS O2 TWO CHIC 50 2T 05-05, GP1 50 2T 01-03, GP1 EU 2.50 2T 05-05, GP1 OPEN EU2 50 2T 06-09, GP1 RACE EU2 50 2T 05-07	ITALJET PIAGGIO	JET SET 50 2T 02-02, TORPEDO NEW 50 2T 00-01 DIESIS 50 2T 01-01, FREE DELIVERY 50 2T 00-01, NRG MC3 50 2T 01-04, NRG POWER DD 50 2T 05-17, NRG POWER DD SERIE SPECIALE 50 2T 07-12, NRG POWER DT 50 2T 06-15, NRG POWER DT SERIE SPECIALE 50 2T 07-08, NRG PUREJET 50 2T-IE 02-04, TYPHOON 50 2T 01-11

◀ **cod. 9922040** 
Cinghia di trasmissione per motori scooter 50 cc Piaggio

RIFERIMENTO ORIGINALE

Piaggio	82645R
---------	--------

APPLICABILITÀ

PIAGGIO	VESPA ET2 INIEZIONE 50 2T 97-00, VESPA ET4 50 4T 00-05, VESPA LX 2T 50 2T 05-13, VESPA LX 2T TOURING & 30KM 50 2T 10-13, VESPA LX 4T 50 4T 05-09, VESPA LX 4T 4V 50 4T 09-13, VESPA LX 4T 4V TOURING 50 4T 10-13, VESPA LXV 2T 50 2T 06-09, VESPA LXV 2T NAVY 50 2T 08-08, VESPA S 2T & COLLEGE 50 2T 07-12, VESPA S 4T 4V & COLLEGE 50 4T 08-12, ZIP 2T 50 2T 08-13, ZIP 4T 50 4T 00-13, ZIP LC 50 2T 00-04, ZIP SP 50 2T 01-04, ZIP SP EURO 2 50 2T 06-13, ZIP 4T 100 4T 06-10
----------------	--

◀ **cod. 9931580** 
Cinghia di trasmissione per motori scooter 50 cc Honda Vision

RIFERIMENTO ORIGINALE

Honda	23100GP901
-------	------------

APPLICABILITÀ

HONDA	VISION 50 2T 88-95
--------------	--------------------

◀ **cod. 9931590** 
Cinghia di trasmissione per motori scooter 50 cc Kymco

RIFERIMENTO ORIGINALE

Kymco	00107541
-------	----------

APPLICABILITÀ

KYMCO	AGILITY 4T CARRY 50 4T 11-11, AGILITY 4T R12 50 4T 07-08, AGILITY PLUS 4T 50 4T 14-14, AGILITY R12 50 4T 05-05, AGILITY R12 ECS 50 4T 16-16, AGILITY R16 50 4T 08-09, AGILITY R16 50 4T 12-12, AGILITY R16 2T 50 2T 10-10, AGILITY R16 2T 50 2T 12-12, AGILITY RS 50 4T 09-09, AGILITY RS NAKED 50 2T 10-10, B&W 50 2T 02-02, B&W EU2 50 2T 03-03, DINK AC 50 2T 98-02, DINK LC 50 2T 98-02, DINK 50 4T 50 4T 07-07, DINK CLASSIC EU2 50 2T 03-03, LIKE 50 4T 09-09, PEOPLE 50 2T 99-04, PEOPLE EURO 2 50 2T 03-03, PEOPLE EURO 2 50 2T 08-08, PEOPLE EURO 2 50 2T 11-11, PEOPLE S 50 2T 05-08, PEOPLE S 4T 50 4T 06-08, SUPER 8 50 2T 09-09, SUPER 8 4T 50 4T 07-07, SUPER 8 4T 50 4T 09-09, SUPER 9 50 2T 00-00, SUPER 9 EU2 50 2T 03-03, TOP BOY 50 2T 97-00, VITALITY 2T 50 2T 04-04, VITALITY 4T 50 4T 04-04, YUP 50 2T 02-02, YUP EU2 50 2T 03-03
--------------	---

CINGHIA DI TRASMISSIONE POMPA ACQUA / MISCELATORE

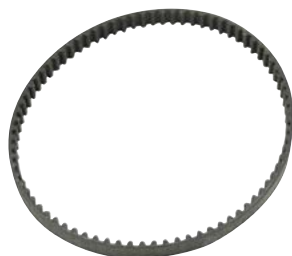

◀ **cod. 9933440**
Cinghia Pompa Acqua/Miscelatore Scooter Piaggio 50 cc



cod. 9923030

Convertitore di coppia per motori scooter 50 cc Minarelli/Yamaha

APPLICABILITÀ

APRILIA AMICO 50 2T 94-94, AMICO 50 2T 96-98, AMICO GL/GLE 50 2T 93-95, AMICO LX/SPORT/CAT 50 2T 92-93, AREA 51 50 2T 98-00, GULLIVER 50 2T 95-98, GULLIVER LC 50 2T 96-98, RALLY 50 2T 95-03, RALLY LIQUID COOLED 50 2T 96-99, SCARABEO 50 2T 93-05, SONIC 50 2T 98-07, SONIC GP 50 2T 98-08, SR (ORIZZONTALE) 50 2T 94-96, SR (VERTICALE) 50 2T 93-93, SR LIQUID COOLED 50 2T 94-96, SR RACING 50 2T 97-99, SR STEALTH 50 2T 97-00, SR WWW 50 2T 97-01

ATALA CAROSELLO 50 2T 99-01

BENELLI 491 GT 50 2T 98-99, 491 NAKED 50 2T 02-02, 491 RACING 50 2T 98-99, 491 RR 50 2T 99-01, 491 SP 50 2T 99-99, 491 SPORT 50 2T 98-99, 491 ST 50 2T 99-01, K2 50 2T 98-01, K2 LIQUID COOLED 50 2T 98-01, PEPE 50 2T 99-01, PEPE 50 2T 10-10, PEPE LX 50 2T 03-04, PEPE LX 50 2T 07-09, PEPE OLD 50 2T 07-09, PEPE OLD 50 2T 11-11, QUATTRONEX 50 2T 08-11

BETA ARK 50 2T 96-08, ARK LC 50 2T 96-08, CHRONO 50 2T 95-96, EIKON 50 2T 99-03, QUADRA 50 2T 95-95, QUADRA 50 2T 99-01, TEMPO 50 2T 93-02, TEMPO 50 2T 95-95

CPI ARAGON 50 2T 03-03, HUSSAR 50 2T 03-03, OLIVER 50 2T 03-03, POP CORN 50 2T 03-03

EXPLORER CRACKER 50 2T 03-03

ITALJET DRAGSTER 50 2T 98-02

KEEWAY ATV EC2 50 2T 06-06, ATV OFF ROAD 50 2T 07-07, F-ACT 50 2T 07-08, FLASH 50 2T 07-08, FOCUS 50 2T 06-06, GOCCIA 50 2T 09-09, HURRICANE 50 2T 06-08, MATRIX 50 2T 06-08, PIXEL EURO 2 50 2T 09-12, RY8 50 2T 08-08

KTM K50 50 2T 96-01

MACAL THUNDER 50 2T 95-96

MALAGUTI CENTRO SL 50 2T 94-98, CIAK 50 2T 99-01, CIAK EURO 2 2.3 50 2T 03-03, CIAK EURO2 50 2T 01-03, CIAK MASTER EURO 2 50 2T 06-06, F10 50 2T 92-00, F10 AC WAP 50 2T 08-08, F10 EURO 2 50 2T 02-06, F10 EURO 2 2.3 50 2T 03-04, F10 RESTYLING EURO 2 50 2T 06-06, F12 PHANTOM 50 2T 94-98, F12 PHANTOM EURO 2 50 2T 02-02, F12 PHANTOM EURO 2 2.3 50 2T 03-04, F12 PHANTOM LC 50 2T 94-98, F12 PHANTOM LC EURO 2 2.3 50 2T 03-04, F12 R PHANTOM AC 50 2T 07-08, F12 R PHANTOM LC 50 2T 07-10, F12 RESTYLING EURO 1 50 2T 99-02, F12 RESTYLING EURO 2 50 2T 06-06, F12 RESTYLING LC EURO 2 50 2T 06-06, F15 FIRE FOX 50 2T 96-98, F15 FIRE FOX AIR COOLED 50 2T 05-06, F15 FIRE FOX EURO 2 50 2T 02-06, F15 FIRE FOX EURO 2 2.3 50 2T 03-04, YESTERDAY 50 2T 97-00

MBK BOOSTER 50 2T 90-04, BOOSTER 50 2T 90-94, BOOSTER EURO 2 50 2T 04-04, BOOSTER NG 50 2T 95-03, BOOSTER ROCKET 50 2T 97-98, BOOSTER SPIRIT 50 2T 96-00, BOOSTER SPIRIT 50 2T 03-03, BOOSTER SPIRIT EURO2 50 2T 03-03, BOOSTER TRACK 50 2T 96-98, EVOLIS 50 2T 92-95, FIZZ 50 2T 94-95, FLIPPER 50 2T 98-04, FLIPPER EURO 2 50 2T 03-03, FORTE 50 2T 94-96, MACH G 50 2T 02-04, MACH GLC 50 2T 02-04, NITRO 50 2T 97-04, NITRO EURO 2 50 2T 03-03, OVETTO 50 2T 97-04, OVETTO EURO 2 50 2T 02-02, STUNT 50 2T 00-02

MOTRON SYNCRO 50 2T 98-00, THUNDER 50 2T 95-98

RIEJU FIRST 50 2T 95-98, WINDY 50 2T 95-98

YAMAHA AEROX 50 2T 97-02, AEROX 50 2T 04-16, AEROX EURO 2 50 2T 03-03, AEROX NAKED 50 2T 13-16, AEROX R 50 2T 99-00, AXIS 50 2T 95-96, BREEZE 50 2T 94-95, BW'S 50 2T 97-16, BW'S BUMP 50 2T 97-98, BW'S EASY 50 2T 13-13, BW'S NAKED 50 2T 03-04, BW'S NAKED 50 2T 09-16, BW'S NEXT GENERATION 50 2T 97-06, BW'S ORIGINAL 50 2T 99-01, BW'S ORIGINAL EURO 2 50 2T 03-03, JOG 50 2T 92-01, JOG R 50 2T 02-02, JOG R EURO2 50 2T 02-02, JOG R EURO2 50 2T 06-15, JOG R LC 50 2T 02-15, NEO'S 50 2T 97-02, NEO'S 50 2T 04-16, NEO'S EASY 50 2T 13-13, NEO'S EURO 2 50 2T 02-02, RS SPY 50 2T 95-98, SLIDER 50 2T 00-02, WHY 50 2T 98-05, WHY EURO 2 50 2T 03-05, ZEST 50 2T 95-92, ZUMA 50 2T 97-01

RICAMBI

9913790	Molla (carico 26 kg)
---------	----------------------



cod. 9923150

Convertitore di coppia per motori scooter 50 cc Piaggio

APPLICABILITÀ

APRILIA MOJITO CUSTOM 2T MOTORE PIAGGIO 50 2T 04-10, SCARABEO 2T EU2 MOTORE PIAGGIO 50 2T 10-12, SCARABEO 2T NET 50 2T 09-10, SCARABEO 4T 50 4T 02-06, SCARABEO 4T 4V 50 4T-4V 10-12, SCARABEO 4T 4V NET 50 4T-4V 09-10, SCARABEO 4T RESTYLING EU3 50 4T 06-09, SCARABEO QUATTRO 50 4T-4V 09-09, SCARABEO STREET 50 2T 05-06, SCARABEO STREET 2T RESTYLING 50 2T 06-09, SPORT CITY ONE 2T 50 2T 08-11, SPORT CITY ONE 4T 50 4T 08-10, SR MOTARD 50 2T 12-14, SR R 50 2T 04-09, SR R FACTORY CARBURATORE 50 2T 10-14, SR R FACTORY IE 50 2T 10-14, SR STREET CARBURATORE 50 2T 03-12

DERBI ATLANTIS 2T 50 2T 10-10, ATLANTIS 2T EU2 50 2T 07-09, ATLANTIS O2 50 2T 02-02, ATLANTIS O2 BULLET 50 2T 03-05, ATLANTIS O2 CITY 50 2T 04-06, ATLANTIS O2 RED BULLET 50 2T 03-03, ATLANTIS O2 TWO CHIC 50 2T 05-05, BOULEVARD 2T 50 2T 09-14, GP1 50 2T 01-03, GP1 EU 2 50 2T 05-05, GP1 OPEN EU2 50 2T 06-09, GP1 RACE EU2 50 2T 05-07, SONAR 2T 50 2T 09-09

GILERA EASY MOVING 50 2T 95-96, ICE 50 2T 01-05, RUNNER 50 2T 97-00, RUNNER PURE JET 50 2T-IE 02-07, RUNNER PURE JET 50 2T-IE 10-11, RUNNER SP 50 2T 02-06, STALKER 50 2T 97-11, STALKER NAKED 50 2T 08-08, STALKER SPECIAL EDITION 50 2T 07-08, STORM 50 2T 94-95, STORM EURO 2 50 2T 07-07, TYPHOON 50 2T 94-97, TYPHOON X 50 2T 98-99, TYPHOON XR 50 2T 00-00

ITALJET JET SET 50 2T 02-02, TORPEDO NEW 50 2T 00-01

PIAGGIO DIESIS 50 2T 01-01, FLY 2T 50 2T 05-07, FLY 2T 50 2T 10-11, FLY 4T 50 4T 05-07, FLY 4T & 25-30 KM/H 50 4T 08-11, FLY 4T MOTORE CHN 50 4T 06-07, FREE 50 2T 92-94, FREE DELIVERY 50 2T 00-01, FREE FL 50 2T 95-02, LIBERTY 50 2T 97-05, LIBERTY 2T 50 2T 06-08, LIBERTY 2T PTT EU2 50 2T 04-05, LIBERTY 2T RST 50 2T 04-04, LIBERTY 2T SPORT 50 2T 06-08, LIBERTY 4T 50 4T 00-02, LIBERTY 4T 50 4T 05-08, LIBERTY 4T DELIVERY - SINGLE 50 4T 10-14, LIBERTY 4T DELIVERY TNT 50 4T 09-09, LIBERTY 4T PTT - DOUBLE - NEXIVE 50 4T 09-17, LIBERTY 4T RST 50 4T 04-04, LIBERTY 4T SPORT 50 4T 06-08, LIBERTY MOC 2T & ELLE 50 2T 09-13, LIBERTY MOC 4T & ELLE 50 4T 09-16, NRG 50 2T 94-96, NRG EXTREME LC 50 2T 99-00, NRG MC3 50 2T 01-04, NRG POWER DD 50 2T 05-17, NRG POWER DD SERIE SPECIALE 50 2T 07-12, NRG POWER DT 50 2T 06-15, NRG POWER DT SERIE SPECIALE 50 2T 07-08, NRG POWER PUREJET 50 2T-IE 04-11, NRG PUREJET 50 2T-IE 02-04, NRG PUREJET 50 2T-IE 10-10, NRG RST MC2 50 2T 96-98, NTT 50 2T 95-96, QUARTZ 50 2T 92-96, SFERA 50 2T 91-93, SFERA MAQUILLAGE 2 50 2T 94-94, SFERA RST 50 2T 95-97, TYPHOON 50 2T 01-11, TYPHOON 2T E2 50 2T 10-12, TYPHOON 2T E3 CH 50 2T 11-11, VESPA ET2 50 2T 97-05, VESPA ET2 INIEZIONE 50 2T 97-00, VESPA ET4 50 4T 00-05, VESPA LX 2 50 2T 05-13, VESPA LX 2 TOURING & 30KM 50 2T 10-13, VESPA LX 4T 50 4T 05-09, VESPA LX 4T 4V 50 4T-4V 09-13, VESPA LX 4T 4V TOURING 50 4T-4V 10-13, VESPA LXV 2T 50 2T 06-09, VESPA LXV 2T NAVY 50 2T 08-08, VESPA S 2T & COLLEGE 50 2T 07-12, VESPA S 4T 4V & COLLEGE 50 4T-4V 08-12, ZIP 50 2T 92-93, ZIP 50 2T 95-96, ZIP 2T 50 2T 08-13, ZIP 4T 50 4T 00-13, ZIP BIMODALE 50 2T 94-97, ZIP FAST RIDER 50 2T 93-94, ZIP FAST RIDER RST 50 2T 96-97, ZIP LC 50 2T 00-04, ZIP RST 50 2T 96-99, ZIP SP 50 2T 96-04, ZIP SP EURO 2 50 2T 06-13

RICAMBI

9912590	Molla (carico 37 kg)
---------	----------------------



◀ cod. **9929180**

RACING

Cuscinetti ad alte prestazioni con sfere maggiorate e anelli carbonitrurati ad elevata scorrevolezza
Serie 2 cuscinetti | Misure: 17 x 47 x 14 | Sigla: 6303ETN9HN1C3H | Adattabile a motori Minarelli AM345/6

◀ cod. **9929190**

RACING

Cuscinetti ad alte prestazioni con sfere maggiorate e anelli carbonitrurati ad elevata scorrevolezza
Serie 2 cuscinetti | Misure: 20 x 47 x 14 | Sigla: 6204ETN9HN1C3H | Adattabile a motori scooter 50 cc Minarelli/Yamaha

◀ cod. **9929300**

RACING

Cuscinetti ad alte prestazioni con sfere maggiorate e anelli carbonitrurati ad elevata scorrevolezza
Serie 2 cuscinetti | Misure: 17 x 47 x 14 - 20 x 47 x 14 | Adattabile ad alberi motore "TPR" cod. 9920410 - 9921720



◀ cod. **9929200**

RACING

Cuscinetti ad alte prestazioni con sfere maggiorate e anelli carbonitrurati ad elevata scorrevolezza
Serie 2 cuscinetti | Misure: 20 x 52 x 12 | Sigla: BB1BB1447205AHN1
Adattabile a motori scooter 50 cc. Piaggio/Gilera/Derbi



cod. 9910020

Frizione alleggerita per tutti i motori scooter 50 cc. Minarelli, Yamaha, Piaggio, Gilera, Derbi, Peugeot, Honda, con campana Ø interno 107 mm

APPLICABILITÀ

APRILIA AMICO 50 2T 94-94, AMICO 50 2T 96-98, AMICO GL/GLE 50 2T 93-95, AMICO LX/SPORT/CAT 50 2T 92-93, AREA 51 50 2T 98-00, GULLIVER 50 2T 95-98, GULLIVER LC 50 2T 96-98, MOJITO CUSTOM 2T MOTORE PIAGGIO 50 2T 04-10, RALLY 50 2T 95-03, RALLY LIQUID COOLED 50 2T 96-99, SCARABEO 50 2T 93-05, SCARABEO 2T EU2 MOTORE PIAGGIO 50 2T 10-12, SCARABEO 2T NET 50 2T 09-10, SCARABEO 4T 50 4T 02-06, SCARABEO 4T 4V 50 4T-4V 10-12, SCARABEO 4T 4V NET 50 4T-4V 09-10, SCARABEO 4T RESTYLING EU3 50 4T 06-09, SCARABEO QUATTRO 50 4T-4V 09-09, SCARABEO STREET 50 2T 05-06, SCARABEO STREET 2T RESTYLING 50 2T 06-09, SONIC 50 2T 98-07, SONIC GP 50 2T 98-08, SPORT CITY ONE 2T 50 2T 08-11, SPORT CITY ONE 4T 50 4T 08-10, SR (ORIZZONTALE) 50 2T 94-96, SR (VERTICALE) 50 2T 93-93, SR LIQUID COOLED 50 2T 94-96, SR MOTARD 50 2T 12-14, SR R 50 2T 04-09, SR R FACTORY CARBURATORE 50 2T 10-14, SR R FACTORY IE 50 2T 10-14, SR RACING 50 2T 97-99, SR STEALTH 50 2T 97-00, SR STREET CARBURATORE 50 2T 03-12, SR WWW 50 2T 97-01

ATALA CAROSELLO 50 2T 99-01

BENELLI 491 GT 50 2T 98-99, 491 NAKED 50 2T 02-02, 491 RACING 50 2T 98-99, 491 RR 50 2T 99-01, 491 SP 50 2T 99-99, 491 SPORT 50 2T 98-99, 491 ST 50 2T 99-01, K2 50 2T 98-01, K2 LIQUID COOLED 50 2T 98-01, PEPE 50 2T 99-01, PEPE LX 50 2T 03-04

BETA ARK 50 2T 96-08, ARK LC 50 2T 96-08, CHRONO 50 2T 95-96, EIKON 50 2T 99-03, QUADRA 50 2T 95-95, QUADRA 50 2T 99-01, TEMPO 50 2T 93-02, TEMPO 50 2T 95-95

BSV DIO GP 50 2T 94-96, DIO SP 50 2T 94-96, DIO ZX 50 2T 94-96

DERBI ATLANTIS 2T 50 2T 10-10, ATLANTIS 2T EU2 50 2T 07-09, ATLANTIS O2 50 2T 02-02, ATLANTIS O2 BULLET 50 2T 03-05, ATLANTIS O2 CITY 50 2T 04-06, ATLANTIS O2 RED BULLET 50 2T 03-03, ATLANTIS O2 TWO CHIC 50 2T 05-05, BOULEVARD 2T 50 2T 09-14, GP1 50 2T 01-03, GP1 EU 2 50 2T 05-05, GP1 OPEN EU2 50 2T 06-09, GP1 RACE EU2 50 2T 05-07, SONAR 2T 50 2T 09-09

GILERA DNA 50 2T 00-02, DNA 50 2T 05-07, DNA GP EXPERIENCE 50 2T 03-04, EASY MOVING 50 2T 95-96, ICE 50 2T 01-05, RUNNER 50 2T 97-00, RUNNER POGGIALI 50 2T 02-02, RUNNER SP 50 2T 02-07, RUNNER SP 50 2T 10-12, RUNNER SP SPECIAL EDITION 50 2T 07-07, RUNNER SP ST & SIMONCELLI 50 2T 08-09, STALKER 50 2T 97-11, STALKER NAKED 50 2T 08-08, STALKER SPECIAL EDITION 50 2T 07-08, STORM 50 2T 94-95, STORM EURO 2 50 2T 07-07, TYPHOON 50 2T 94-97, TYPHOON X 50 2T 98-99

HONDA BALL 50 2T 93-99, DIO ZX 50 2T 94-96, SFX / SXR 50 2T 95-01, SGX SKY 50 2T 97-04, SH NEW 50 2T 96-01

HSC SC 01 50 2T 94-96, SC 01 L 50 2T 94-96

ITALJET BAZOOKA 50 2T 91-94, DRAGSTER 50 2T 98-02, JET SET 50 2T 02-02, PISTA 50 2T 92-97, PISTA 2 50 2T 97-98, SCOOP 50 2T 91-95, SCOOP 2 50 2T 96-98, TORPEDO NEW 50 2T 00-01, YANKEE 50 2T 93-97

KTM K50 50 2T 96-01

KYMCO AGILITY R12 50 4T 05-05

MACAL THUNDER 50 2T 95-96

MALAGUTI CENTRO SL 50 2T 94-98, CIAK 50 2T 99-01, CIAK EURO 2,2 50 2T 03-03, CIAK EURO2 50 2T 01-03, F10 50 2T 92-00, F10 EURO 2 50 2T 02-06, F10 EURO 2,2 50 2T 03-04, F12 PHANTOM 50 2T 94-98, F12 PHANTOM EURO 2 50 2T 02-02, F12 PHANTOM EURO 2,2 50 2T 03-04, F12 PHANTOM LC 50 2T 94-98, F12 PHANTOM LC EURO 2,2 50 2T 03-04, F12 RESTYLING EURO 1 50 2T 99-02, F12 RESTYLING EURO 2 50 2T 06-06, F15 FIRE FOX 50 2T 96-98, F15 FIRE FOX EURO 2 50 2T 02-03, F15 FIRE FOX EURO 2,2 50 2T 03-04, YESTERDAY 50 2T 97-00

MBK BOOSTER 50 2T 90-04, BOOSTER 50 2T 90-94, BOOSTER EURO 2 50 2T 04-04, BOOSTER NG 50 2T 95-03, BOOSTER ROCKET 50 2T 97-98, BOOSTER SPIRIT 50 2T 96-00, BOOSTER SPIRIT 50 2T 03-03, BOOSTER SPIRIT EURO2 50 2T 03-03, BOOSTER TRACK 50 2T 96-98, FLIPPER 50 2T 98-04, FLIPPER EURO 2 50 2T 03-03, MACH G 50 2T 02-04, MACH G LC 50 2T 02-04, NITRO 50 2T 97-04, NITRO EURO 2 50 2T 03-03, OVETTO 50 2T 97-04, OVETTO EURO 2 50 2T 02-02, SORRISO 50 2T 95-96, STUNT 50 2T 00-02, TARGET 50 2T 91-95

MOTRON SYNCRO 50 2T 98-00, THUNDER 50 2T 95-98

PEUGEOT BUXY 50 2T 90-02, BUXY RS 50 2T 90-02, ELYSEO 50 2T 90-02, JET FORCE 50 2T 90-02, LOOKOR 50 2T 90-02, METAL X 50 2T 90-02, SPEEDAKE 50 2T 90-02, SPEEDFIGHT 50 2T 97-04, SPEEDFIGHT LC 50 2T 97-04, SQUAB 50 2T 90-02, SV GEO 50 2T 90-02, TREKKER 50 2T 90-02, VIVACITY 50 2T 90-02, X-FIGHT 50 2T 00-02, ZENITH 50 2T 90-02

PIAGGIO DIESIS 50 2T 01-01, FLY 2T 50 2T 05-07, FLY 2T 50 2T 10-11, FLY 4T 50 4T 05-07, FLY 4T & 25-30 KM/H 50 4T 08-11, FLY 4T MOTORE CHN 50 4T 06-07, FREE 50 2T 92-94, FREE DELIVERY 50 2T 00-01, LIBERTY 50 2T 97-05, LIBERTY 2T 50 2T 06-08, LIBERTY 2T PTT EU2 50 2T 04-05, LIBERTY 2T RST 50 2T 04-04, LIBERTY 2T SPORT 50 2T 06-08, LIBERTY 4T 50 4T 00-02, LIBERTY 4T 50 4T 05-08, LIBERTY 4T 3V IE 50 4T-3V 15-17, LIBERTY 4T 3V IE E4 50 4T-3V 17-18, LIBERTY 4T DELIVERY - SINGLE 50 4T 10-14, LIBERTY 4T DELIVERY TNT 50 4T 09-09, LIBERTY 4T IGET CORPORATE E4 50 4T-3V 18-20, LIBERTY 4T PTT - DOUBLE - NEXIVE 50 4T 09-17, LIBERTY 4T RST 50 4T 04-04, LIBERTY 4T SPORT 50 4T 06-08, LIBERTY IGET 4T 3V IE E4 EMEA 50 4T-3V 17-19, LIBERTY MOC 2T & ELLE 50 2T 09-13, LIBERTY MOC 4T & ELLE 50 4T 09-16, NRG 50 2T 94-96, NRG POWER DT 50 2T 06-15, NRG POWER DT SERIE SPECIALE 50 2T 07-08, NRG RST MC2 50 2T 96-98, NTT 50 2T 95-96, QUARTZ 50 2T 92-96, SFERA 50 2T 91-93, SFERA MAQUILLAGE 2 50 2T 94-94, SFERA RST 50 2T 97-97, TYPHOON 2T E2 50 2T 10-12, TYPHOON 2T E3 CH 50 2T 11-11, VESPA ET2 50 2T 97-05, VESPA ET4 50 4T 00-05, VESPA PRIMAVERA 4T 3V NOABS E4 50 4T-3V 17-18, VESPA SPRINT 4T 3V E4 50 4T-3V 17-20, ZIP 50 2T 92-93, ZIP 50 2T 95-96, ZIP 4T 50 4T 00-13, ZIP BIMODALE 50 2T 94-97, ZIP FAST RIDER 50 2T 93-94, ZIP FAST RIDER RST 50 2T 96-97, ZIP RST 50 2T 96-99, ZIP SP 50 2T 96-00

RIEJU FIRST 50 2T 95-98, WINDY 50 2T 95-98

YAMAHA AEROX 50 2T 97-02, AEROX 50 2T 04-16, AEROX EURO 2 50 2T 03-03, AEROX NAKED 50 2T 13-16, AEROX R 50 2T 99-00, BW'S 50 2T 97-16, BW'S BUMP 50 2T 97-98, BW'S EASY 50 2T 13-13, BW'S NAKED 50 2T 03-04, BW'S NAKED 50 2T 09-16, BW'S NEXT GENERATION 50 2T 97-06, BW'S ORIGINAL 50 2T 99-01, BW'S ORIGINAL EURO 2 50 2T 03-03, CRZ 50 2T 91-95, CT 50 2T 90-95, JOG R 50 2T 02-02, JOG R EURO2 50 2T 02-02, JOG R EURO2 50 2T 06-15, JOG R LC 50 2T 02-15, NEO'S 50 2T 97-02, NEO'S 50 2T 04-16, NEO'S EASY 50 2T 13-13, NEO'S EURO 2 50 2T 02-02, RS SPY 50 2T 95-98, SLIDER 50 2T 00-02, WHY 50 2T 98-05, WHY EURO 2 50 2T 03-05, ZUMA 50 2T 97-01



cod. 9911060

Frizione alleggerita per tutti i motori scooter 50 cc Minarelli/Yamaha, con campana Ø interno 105 mm

APPLICABILITÀ

APRILIA AMICO 50 2T 94-94, AMICO 50 2T 96-98, AMICO GL/GLE 50 2T 93-95, AMICO LX/SPORT/CAT 50 2T 92-93, AREA 51 50 2T 98-00, GULLIVER 50 2T 95-98, GULLIVER LC 50 2T 96-98, RALLY 50 2T 95-03, RALLY LIQUID COOLED 50 2T 96-99, SCARABEO 50 2T 93-05, SONIC 50 2T 98-07, SONIC GP 50 2T 98-08, SR (ORIZZONTALE) 50 2T 94-96, SR (VERTICALE) 50 2T 93-93, SR LIQUID COOLED 50 2T 94-96, SR RACING 50 2T 97-99, SR STEALTH 50 2T 97-00, SR WWW 50 2T 97-01

ATALA CAROSELLO 50 2T 99-01

BENELLI 491 GT 50 2T 98-99, 491 NAKED 50 2T 02-02, 491 RACING 50 2T 98-99, 491 RR 50 2T 99-01, 491 SP 50 2T 99-99, 491 SPORT 50 2T 98-99, 491 ST 50 2T 99-01, K2 50 2T 98-01, K2 LIQUID COOLED 50 2T 98-01, PEPE 50 2T 99-01, PEPE LX 50 2T 03-04

BETA ARK 50 2T 96-08, ARK LC 50 2T 96-08, CHRONO 50 2T 95-96, EIKON 50 2T 99-03, QUADRA 50 2T 95-95, QUADRA 50 2T 99-01, TEMPO 50 2T 93-02, TEMPO 50 2T 95-95

ITALJET BAZOOKA 50 2T 91-94, DRAGSTER 50 2T 98-02, PISTA 50 2T 92-97, PISTA 2 50 2T 97-98, SCOOP 50 2T 91-95, SCOOP 2 50 2T 96-98, YANKEE 50 2T 93-97

KTM K50 50 2T 96-01

MACAL THUNDER 50 2T 95-96

MALAGUTI CENTRO SL 50 2T 94-98, CIAK 50 2T 99-01, CIAK EURO 2,2 50 2T 03-03, CIAK EURO2 50 2T 01-03, F10 50 2T 92-00, F10 EURO 2 50 2T 02-06, F10 EURO 2,2 50 2T 03-04, F12 PHANTOM 50 2T 94-98, F12 PHANTOM EURO 2,2 50 2T 03-04, F12 PHANTOM LC 50 2T 94-98, F12 PHANTOM LC EURO 2,2 50 2T 03-04, F12 RESTYLING EURO 2 50 2T 06-06, F15 FIRE FOX 50 2T 96-98, F15 FIRE FOX EURO 2 50 2T 02-03, F15 FIRE FOX EURO 2,2 50 2T 03-04, YESTERDAY 50 2T 97-00

MBK BOOSTER 50 2T 90-04, BOOSTER 50 2T 90-94, BOOSTER EURO 2 50 2T 04-04, BOOSTER NG 50 2T 95-03, BOOSTER ROCKET 50 2T 97-98, BOOSTER SPIRIT 50 2T 96-00, BOOSTER SPIRIT 50 2T 03-03, BOOSTER SPIRIT EURO2 50 2T 03-03, BOOSTER TRACK 50 2T 96-98, FLIPPER 50 2T 98-04, FLIPPER EURO 2 50 2T 03-03, MACH G 50 2T 02-04, MACH G LC 50 2T 02-04, NITRO 50 2T 97-04, NITRO EURO 2 50 2T 03-03, OVETTO 50 2T 97-04, OVETTO EURO 2 50 2T 02-02, SORRISO 50 2T 95-96, STUNT 50 2T 00-02, TARGET 50 2T 91-95

MOTRON SYNCRO 50 2T 98-00, THUNDER 50 2T 95-98

RIEJU FIRST 50 2T 95-98, WINDY 50 2T 95-98

YAMAHA AEROX 50 2T 97-02, AEROX 50 2T 04-16, AEROX EURO 2 50 2T 03-03, AEROX NAKED 50 2T 13-16, AEROX R 50 2T 99-00, BW'S 50 2T 97-16, BW'S BUMP 50 2T 97-98, BW'S EASY 50 2T 13-13, BW'S NAKED 50 2T 03-04, BW'S NAKED 50 2T 09-16, BW'S NEXT GENERATION 50 2T 97-06, BW'S ORIGINAL 50 2T 99-01, BW'S ORIGINAL EURO 2 50 2T 03-03, CRZ 50 2T 91-95, CT 50 2T 90-95, JOG R 50 2T 02-02, JOG R EURO2 50 2T 02-02, JOG R EURO2 50 2T 06-15, JOG R LC 50 2T 02-15, NEO'S 50 2T 97-02, NEO'S 50 2T 04-16, NEO'S EASY 50 2T 13-13, NEO'S EURO 2 50 2T 02-02, RS SPY 50 2T 95-98, SLIDER 50 2T 00-02, WHY 50 2T 98-05, WHY EURO 2 50 2T 03-05, ZUMA 50 2T 97-01



◀ cod. **9918550**

RACING

Frizione a denti dritti Z=18/68 per motori Minarelli AM

NB: Montando questa coppia frizione è indispensabile eliminare il miscelatore automatico ed il contagiri meccanico.

RICAMBI

9918510	Ingranaggio pompa acqua condotto Z=30
9920580	Serie molle frizione am rinforz.100 Kg.

9938000	Campana frizione con ribattini
---------	--------------------------------

APPLICABILITÀ

<p>APRILIA CLASSIC 50 2T 92-99, EUROPA 50 2T 91-92, MX 50 2T 04-04, MX MOTARD 50 2T 95-03, PEGASO 50 2T 92-94, RS 50 2T 91-05, RX 50 2T 03-04, RX 3-5 MARCE 50 2T 91-94, RX ENDURO 50 2T 95-03, RX RACING 50 2T 03-06, TUONO 50 2T 03-04</p> <p>BETA RR 2T 50 EU4 50 2T 18-20, RR 50 RACING EU4 50 2T 18-20, RR ALU 50 2T 08-12, RR ENDURO 50 2T 06-17, RR MOTARD 50 2T 06-17</p> <p>CH HUSQUARNA SM 50 2T 00-10, WR 50 2T 00-10, WSM 50 2T 00-10</p> <p>CMC ENDURO 50 2T 11-11, MOTARD 50 2T 11-11</p> <p>FANTIC CABALLERO MOTARD 50 2T 06-10, CABALLERO MOTARD COMPETITION 50 2T 06-10, CABALLERO REGOLARITÀ 50 2T 06-10, CABALLERO REGOLARITÀ COMPETITION 50 2T 06-10, ENDURO COMPETITION EU4 50 2T 18-20, ENDURO PERFORMANCE EU4 50 2T 18-20, MOTARD COMPETITION EU4 50 2T 18-20, MOTARD PERFORMANCE EU4 50 2T 18-20</p> <p>HM BAJA, DERAPAGE BASIC 50 2T 10-11, CMC 50 2T 10-11, CRE BAJA RR, DERAPAGE RR 50 2T 07-11, CRE BAJA, DERAPAGE 50 2T 07-11, CRE SIX COMPETITION 50 2T 10-11, CRE SIX, BAJA, DERAPAGE 50 2T 95-06, CRE SIX, DERAPAGE COMPETITION 50 2T 07-09, DERAPAGE COMPETITION 50 2T 10-11</p> <p>MALAGUTI CNK DRAGON 50 2T 05-07, FIFTY EVOLUTION 50 2T 90-93, XSM 50 2T 03-06, XSM POWER-UP 50 2T 07-10, XTM 50 2T 03-03, XTM 50 2T 06-06, XTM POWER-UP 50 2T 07-10</p>	<p>MBK X LIMIT 50 2T 03-04, X POWER 50 2T 03-04</p> <p>MINARELLI MOTORE AM 3-4-5 50 2T 91-95, MOTORE AM 6 1° SERIE 50 2T 96-11, MOTORE AM 6 2° SERIE 50 2T 12-18</p> <p>MOTORHISPANIA FURIA 50 2T 97-00, FURIA MAX 50 2T 10-12, RX 50 2T 09-12, RX R 50 2T 09-12</p> <p>PEUGEOT SUPERMOTARD 50 2T 90-02, XP6 TRAIL S/AVV. ELETTRICO 50 2T 90-02, XR6 RACING CAT. C/AVV.ELETT. 50 2T 90-02</p> <p>RIEJU MRT 50 2T 09-12, MRT 50 EU4 50 2T 18-20, MRT PRO 50 2T 09-12, MRT PRO EU4 50 2T 18-20, MRT PRO REPLICA EU4 50 2T 18-20, MRT PRO REPLICA SM EU4 50 2T 18-20, MRT PRO SM 50 2T 09-12, MRT PRO SM EU4 50 2T 18-20, MRT SM 50 2T 09-12, MRT SM EU4 50 2T 18-20, MRT TROPHY EU4 50 2T 18-20, MRX 50 2T 01-04, MRX PRO 50 2T 01-04, RR 50 2T 05-06, RS1 50 2T 98-01, RS2 MATRIX 50 2T 05-06, RS2 MATRIX PRO 50 2T 05-06, RS2 NAKED 50 2T 04-05, RS3 EU4 50 2T 18-20, RS3 NKD EU4 50 2T 18-20, SMX E.S./K.S. 50 2T 01-01, SMX PRO E.S./K.S. 50 2T 03-03, SPIKE 50 2T 98-01</p> <p>SHERCO FACTORY SE-R EU4 50 2T 18-20, FACTORY SE-RS EU4 50 2T 18-20, FACTORY SILVER SM-R EU4 50 2T 18-20, FACTORY SILVER SM-RS EU4 50 2T 18-20, FACTORY SM-R EU4 50 2T 18-20, FACTORY SM-RS EU4 50 2T 18-20, HRD ENDURO 50 2T 09-13, HRD MOTARD 50 2T 09-13</p> <p>VENT BAJA 50 2T 18-20, BAJA RR 50 2T 18-20, DERAPAGE 50 2T 18-20, DERAPAGE RR 50 2T 18-20</p> <p>YAMAHA DT R 50 2T 03-11, DT RSM 50 2T 03-05, DT X 50 2T 06-11, TZR 50 2T 03-08, TZR 50 2T 10-11, TZR RR 50 2T 05-05</p>
---	--

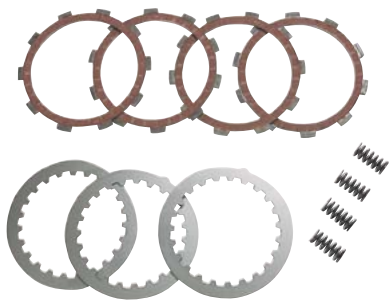

◀ cod. **9920250**

Serie dischi frizione AM 345/6

RICAMBI

9920580	Serie molle frizione AM rinforzate 100 kg
---------	---

APPLICABILITÀ

<p>APRILIA CLASSIC 50 2T 92-99, EUROPA 50 2T 91-92, MX 50 2T 04-04, MX MOTARD 50 2T 95-03, PEGASO 50 2T 92-94, RS 50 2T 91-05, RX 50 2T 03-04, RX 3-5 MARCE 50 2T 91-94, RX ENDURO 50 2T 95-03, RX RACING 50 2T 03-06, TUONO 50 2T 03-04</p> <p>BETA RR 2T 50 EU4 50 2T 18-20, RR 50 RACING EU4 50 2T 18-20, RR ALU 50 2T 08-12, RR ENDURO 50 2T 06-17, RR MOTARD 50 2T 06-17</p> <p>CH HUSQUARNA SM 50 2T 00-10, WR 50 2T 00-10, WSM 50 2T 00-10</p> <p>CMC ENDURO 50 2T 11-11, MOTARD 50 2T 11-11</p> <p>FANTIC CABALLERO MOTARD 50 2T 06-10, CABALLERO MOTARD COMPETITION 50 2T 06-10, CABALLERO REGOLARITÀ 50 2T 06-10, CABALLERO REGOLARITÀ COMPETITION 50 2T 06-10, ENDURO COMPETITION EU4 50 2T 18-20, ENDURO PERFORMANCE EU4 50 2T 18-20, MOTARD COMPETITION EU4 50 2T 18-20, MOTARD PERFORMANCE EU4 50 2T 18-20</p> <p>HM BAJA, DERAPAGE BASIC 50 2T 10-11, CMC 50 2T 10-11, CRE BAJA RR, DERAPAGE RR 50 2T 07-11, CRE BAJA, DERAPAGE 50 2T 07-11, CRE SIX COMPETITION 50 2T 10-11, CRE SIX, BAJA, DERAPAGE 50 2T 95-06, CRE SIX, DERAPAGE COMPETITION 50 2T 07-09, DERAPAGE COMPETITION 50 2T 10-11</p> <p>MALAGUTI CNK DRAGON 50 2T 05-07, FIFTY EVOLUTION 50 2T 90-93, XSM 50 2T 03-06, XSM POWER-UP 50 2T 07-10, XTM 50 2T 03-03, XTM 50 2T 06-06, XTM POWER-UP 50 2T 07-10</p>	<p>MBK X LIMIT 50 2T 03-04, X POWER 50 2T 03-04</p> <p>MINARELLI MOTORE AM 3-4-5 50 2T 91-95, MOTORE AM 6 1° SERIE 50 2T 96-11, MOTORE AM 6 2° SERIE 50 2T 12-18</p> <p>MOTORHISPANIA FURIA 50 2T 97-00, FURIA MAX 50 2T 10-12, RX 50 2T 09-12, RX R 50 2T 09-12</p> <p>PEUGEOT SUPERMOTARD 50 2T 90-02, XP6 TRAIL S/AVV. ELETTRICO 50 2T 90-02, XR6 RACING CAT. C/AVV.ELETT. 50 2T 90-02</p> <p>RIEJU MRT 50 2T 09-12, MRT 50 EU4 50 2T 18-20, MRT PRO 50 2T 09-12, MRT PRO EU4 50 2T 18-20, MRT PRO REPLICA EU4 50 2T 18-20, MRT PRO REPLICA SM EU4 50 2T 18-20, MRT PRO SM 50 2T 09-12, MRT PRO SM EU4 50 2T 18-20, MRT SM 50 2T 09-12, MRT SM EU4 50 2T 18-20, MRT TROPHY EU4 50 2T 18-20, MRX 50 2T 01-04, MRX PRO 50 2T 01-04, RR 50 2T 05-06, RS1 50 2T 98-01, RS2 MATRIX 50 2T 05-06, RS2 MATRIX PRO 50 2T 05-06, RS2 NAKED 50 2T 04-05, RS3 EU4 50 2T 18-20, RS3 NKD EU4 50 2T 18-20, SMX E.S./K.S. 50 2T 01-01, SMX PRO E.S./K.S. 50 2T 03-03, SPIKE 50 2T 98-01</p> <p>SHERCO FACTORY SE-R EU4 50 2T 18-20, FACTORY SE-RS EU4 50 2T 18-20, FACTORY SILVER SM-R EU4 50 2T 18-20, FACTORY SILVER SM-RS EU4 50 2T 18-20, FACTORY SM-R EU4 50 2T 18-20, FACTORY SM-RS EU4 50 2T 18-20, HRD ENDURO 50 2T 09-13, HRD MOTARD 50 2T 09-13</p> <p>VENT BAJA 50 2T 18-20, BAJA RR 50 2T 18-20, DERAPAGE 50 2T 18-20, DERAPAGE RR 50 2T 18-20</p> <p>YAMAHA DT R 50 2T 03-11, DT RSM 50 2T 03-05, DT X 50 2T 06-11, TZR 50 2T 03-08, TZR 50 2T 10-11, TZR RR 50 2T 05-05</p>
---	--



cod. 9921180 **RACING**

Serie dischi frizione AM cellulosa/kevlar per motori Minarelli AM

RICAMBI

9920580 Serie molle frizione AM rinforzate 100 KG

APPLICABILITÀ

APRILIA CLASSIC 50 2T 92-99, EUROPA 50 2T 91-92, MX 50 2T 04-04, MX MOTARD 50 2T 95-03, PEGASO 50 2T 92-94, RS 50 2T 91-05, RX 50 2T 03-04, RX 3-5 MARCE 50 2T 91-94, RX ENDURO 50 2T 95-03, RX RACING 50 2T 03-06, TUONO 50 2T 03-04

BETA RR 2T 50 EU4 50 2T 18-20, RR 50 RACING EU4 50 2T 18-20, RR ALU 50 2T 08-12, RR ENDURO 50 2T 06-17, RR MOTARD 50 2T 06-17

CH HUSQVARNA SM 50 2T 00-10, WR 50 2T 00-10, WSM 50 2T 00-10

CMC ENDURO 50 2T 11-11, MOTARD 50 2T 11-11

FANTIC CABALLERO MOTARD 50 2T 06-10, CABALLERO REGOLARITÀ 50 2T 06-10, ENDURO COMPETITION EU4 50 2T 18-20, ENDURO PERFORMANCE EU4 50 2T 18-20, MOTARD COMPETITION EU4 50 2T 18-20, MOTARD PERFORMANCE EU4 50 2T 18-20

HM

BAJA, DERAPAGE BASIC 50 2T 10-11, CMC 50 2T 10-11, CRE BAJA RR, DERAPAGE RR 50 2T 07-11, CRE BAJA, DERAPAGE 50 2T 07-11, CRE SIX COMPETITION 50 2T 10-11, CRE SIX, BAJA, DERAPAGE 50 2T 95-06, CRE SIX, DERAPAGE COMPETITION 50 2T 07-09, DERAPAGE COMPETITION 50 2T 10-11

MALAGUTI

CNK DRAGON 50 2T 05-07, FIFTY EVOLUTION 50 2T 90-93, XSM 50 2T 03-03, XTM 50 2T 03-03

MBK

X LIMIT 50 2T 03-04, X POWER 50 2T 03-04

MINARELLI

MOTORE AM 3-4-5 50 2T 91-95, MOTORE AM 6 1° SERIE 50 2T 96-11, MOTORE AM 6 2° SERIE 50 2T 12-18

MOTOR

FURIA 50 2T 97-00, FURIA MAX 50 2T 10-12, RX 50 2T 09-12, RX R 50 2T 09-12

HISPANIA

PEUGEOT

SUPERMOTARD 50 2T 90-02, XP6 TRAIL S/AVV. ELETTRICO 50 2T 90-02, XR6 RACING CAT. C/AVV.ELETT. 50 2T 90-02

RIEJU

MRT 50 2T 09-12, MRT 50 EU4 50 2T 18-20, MRT PRO 50 2T 09-12, MRT PRO EU4 50 2T 18-20, MRT PRO REPLICA EU4 50 2T 18-20, MRT PRO REPLICA SM EU4 50 2T 18-20, MRT PRO SM 50 2T 09-12, MRT SM EU4 50 2T 18-20, MRT TROPHY EU4 50 2T 18-20, MRX 50 2T 01-04, MRX PRO 50 2T 01-04, RR 50 2T 05-06, RS1 50 2T 98-01, RS2 MATRIX 50 2T 05-06, RS2 MATRIX PRO 50 2T 05-06, RS2 NAKED 50 2T 04-05, RS3 EU4 50 2T 18-20, RS3 NKD EU4 50 2T 18-20, SMX E.S./K.S. 50 2T 01-01, SMX PRO E.S./K.S. 50 2T 03-03, SPIKE 50 2T 98-01

SHERCO

FACTORY SE-R EU4 50 2T 18-20, FACTORY SE-RS EU4 50 2T 18-20, FACTORY SILVER SM-R EU4 50 2T 18-20, FACTORY SILVER SM-RS EU4 50 2T 18-20, FACTORY SM-R EU4 50 2T 18-20, FACTORY SM-RS EU4 50 2T 18-20, HRD ENDURO 50 2T 09-13, HRD MOTARD 50 2T 09-13

VENT

BAJA 50 2T 18-20, BAJA RR 50 2T 18-20, DERAPAGE 50 2T 18-20, DERAPAGE RR 50 2T 18-20

YAMAHA

DT R 50 2T 03-11, DT RSM 50 2T 03-05, DT X 50 2T 06-11, TZR 50 2T 03-08, TZR 50 2T 10-11, TZR RR 50 2T 05-05



cod. 9923190 **RACING**

Serie dischi frizione cellulosa/kevlar Derbi

RICAMBI

9923180 Serie molle frizione rinforzate per Derbi

APPLICABILITÀ

APRILIA RS 50 2T 06-10, RS4 50 2T 11-13, RS4 REPLICA 50 2T 14-16, RX 50 2T 06-16, SX 50 2T 06-16, SX LIMITED EDITION 50 2T 14-16

DERBI BULTACO LOBITO 50 2T 98-01, GPR 2T 50 2T 13-13, GPR 2T EU2 50 2T 09-10, GPR NUDE 50 2T 04-05, GPR NUDE & GPR NUDE TUNING 50 2T 06-08, GPR NUDE SPORT 50 2T 06-06, GPR R 50 2T 97-00, GPR R EU2 - GPR REPLICA EU2 50 2T 08-08, GPR RACING 50 2T 04-05, GPR RACING EU2 50 2T 06-06, GPR REPLICA 50 2T 99-01, GPR REPLICA & GPR R EU2 50 2T 06-06, GPR REPLICA 2T MALOSSÌ 50 2T 07-07, GPR REPLICA PESEK EU2 50 2T 07-07, GPR REPLICA RACING 50 2T 02-03, GPR REPLICA RACING EU2 50 2T 05-05, SENDA BLACK EDITION 50 2T 03-03, SENDA HYP DRD EVO EU2 50 2T 08-09, SENDA HYP DRD EVO LIMITED EDITION EU2 50 2T 08-08, SENDA R 50 2T 99-01, SENDA R DRD BLACK DEVIL ZA EDIZIONE 50 2T 03-03,

SEDA R DRD EU1 EU1R 50 2T 02-02, SENDA R DRD PRO EU2 50 2T 05-11, SENDA R DRD RACING 50 2T 04-05, SENDA R DRD RACING EU2 50 2T 05-08, SENDA R DRD RACING LTD 50 2T 05-05, SENDA R DRD X-TREME-10, SENDA SM X-TREME EU2 50 2T 04-08, SENDA SM X-TREME EU2 2A EDIZIONE 50 2T 05-05 2T EU2 50 2T 14-15, SENDA R DRD X-TREME 2T EURO2 50 2T 10-12, SENDA R RACER 50 2T 03-03, SENDA R X-RACE 50 2T 04-05, SENDA R X-RACE 2T EU2 50 2T 10-10, SENDA R X-RACE EU2 50 2T 06-09, SENDA R X-TREME 50 2T 03-03, SENDA R X-TREME 50 2T 05-05, SENDA R X-TREME 2T EU2 50 2T 10-10, SENDA R X-TREME EU2 50 2T 04-08, SENDA SM 50 2T 00-01, SENDA SM DRD EDITION BLACK 50 2T 05-05, SENDA SM DRD EU1 EU1R 50 2T 02-03, SENDA SM DRD PRO EU2 50 2T 05-11, SENDA SM DRD PRO EU2 2VER 50 2T 05-08, SENDA SM DRD RACING 50 2T 04-05, SENDA SM DRD

RACING EU2 50 2T 05-08, SENDA SM DRD RACING EU2 50 2T 10-13, SENDA SM DRD RACING LTD 50 2T 05-05, SENDA SM DRD RACING LTD EU2 50 2T 07-07, SENDA SM DRD X-TREME 2T EU2 50 2T 14-15, SENDA SM DRD X-TREME 2T EU2 LIMITED ED 50 2T 14-15, SENDA SM X-RACE 50 2T 04-05, SENDA SM X-RACE 2T EU2 50 2T 10-10, SENDA SM X-RACE EU2 50 2T 06-09, SENDA SM X-RACE EU2 2VER 50 2T 07-09, SENDA SM X-TREME 50 2T 02-03, SENDA SM X-TREME 2T EU2 50 2T 10

GILERA

GSM 50 2T 01-01, RCR 50 2T 03-03, RCR 50 2T 06-07, RCR 50 2T 11-12, RCR (CHE-SYC) 50 2T 13-15, SMT 50 2T 03-03, SMT 50 2T 06-17, SMT RACING 50 2T 11-12

VALENTI RACING

RME 50 2T 15-17, SM 50 2T 15-17



◀ cod. **9925130**
Frizione con campana Ø interno 107 mm

APPLICABILITÀ

APRILIA AMICO 50 2T 94-94, AMICO 50 2T 96-98, AMICO GL/GLE 50 2T 93-95, AMICO LX/SPORT/CAT 50 2T 92-93, AREA 51 50 2T 98-00, GULLIVER 50 2T 95-98, GULLIVER LC 50 2T 96-98, RALLY 50 2T 95-03, RALLY LIQUID COOLED 50 2T 96-99, SCARABEO 50 2T 93-05, SONIC 50 2T 98-07, SONIC GP 50 2T 98-08, SR (ORIZZONTALE) 50 2T 94-96, SR (VERTICALE) 50 2T 93-93, SR LIQUID COOLED 50 2T 94-96, SR RACING 50 2T 97-99, SR STEALTH 50 2T 97-00, SR WWW 50 2T 97-01

ATALA CAROSELLO 50 2T 99-01

BENELLI 491 GT 50 2T 98-99, 491 NAKED 50 2T 02-02, 491 RACING 50 2T 98-99, 491 RR 50 2T 99-01, 491 SP 50 2T 99-99, 491 SPORT 50 2T 98-99, 491 ST 50 2T 99-01, K2 50 2T 98-01, K2 LIQUID COOLED 50 2T 98-01, PEPE 50 2T 99-01, PEPE 50 2T 10-10, PEPE LX 50 2T 03-04, PEPE LX 50 2T 07-09, PEPE OLD 50 2T 07-09, PEPE OLD 50 2T 11-11, QUATTRONONEX 50 2T 08-11

BETA ARK 50 2T 96-08, ARK LC 50 2T 96-08, CHRONO 50 2T 95-96, EIKON 50 2T 99-03, QUADRA 50 2T 95-95, QUADRA 50 2T 99-01, TEMPO 50 2T 93-02, TEMPO 50 2T 95-95

CPI ARAGON 50 2T 03-03, HUSSAR 50 2T 03-03, OLIVER 50 2T 03-03, POP CORN 50 2T 03-03

DINLI HELIX DL603 50 2T 07-13, HELIX DL603 90 50 2T 07-13, T-REX 50 2T 07-13

E-TON VIPER RXL 50 2T 06-06

ITALJET DRAGSTER 50 2T 98-02

KEEWAY ATV EC2 50 2T 06-06, ATV OFF ROAD 50 2T 07-07, F-ACT 50 2T 07-08, FLASH 50 2T 07-08, FOCUS 50 2T 06-06, GOCCIA 50 2T 09-09, HURRICANE 50 2T 06-08, MATRIX 50 2T 06-08, PIXEL EURO 2 50 2T 09-12, RV8 50 2T 08-08

KTM K50 50 2T 96-01

LAVERDA QUASAR 50 2T 02-04

MACAL THUNDER 50 2T 95-96

MALAGUTI CENTRO SL 50 2T 94-98, CIAK 50 2T 99-01, CIAK EURO 2 2,3 50 2T 03-03, CIAK EURO2 50 2T 01-03, CIAK MASTER EURO 2 50 2T 06-06, F10 50 2T 92-00, F10 ACWAP 50 2T 08-08, F10 EURO 2 50 2T 02-06, F10 EURO 2,2,3 50 2T 03-04, F10 RESTYLING EURO 2 50 2T 06-06, F12 PHANTOM 50 2T 94-98, F12 PHANTOM EURO 2 50 2T 02-02, F12 PHANTOM EURO 2 2,3 50 2T 03-04, F12 PHANTOM LC 50 2T 94-98, F12 PHANTOM LC EURO 2 2,3 50 2T 03-04, F12 R PHANTOM AC 50 2T 07-08, F12 R PHANTOM LC 50 2T 07-10, F12 RESTYLING EURO 1 50 2T 99-02, F12 RESTYLING EURO 2 50 2T 06-06, F12 RESTYLING LC EURO 2 50 2T 06-06, F15 FIRE FOX 50 2T 96-98, F15 FIRE FOX AIR COOLED 50 2T 05-06, F15 FIRE FOX EURO 2 50 2T 02-06, F15 FIRE FOX EURO 2,2,3 50 2T 03-04, YESTERDAY 50 2T 97-00

MBK BOOSTER 50 2T 90-04, BOOSTER 50 2T 90-94, BOOSTER EURO 2 50 2T 04-04, BOOSTER NG 50 2T 95-03, BOOSTER ROCKET 50 2T 97-98, BOOSTER SPIRIT 50 2T 96-00, BOOSTER SPIRIT 50 2T 03-03, BOOSTER SPIRIT EURO2 50 2T 03-03, BOOSTER TRACK 50 2T 96-98, BOOSTER X IE 50 4T-3V 08-08, EVOLIS 50 2T 92-95, FIZZ 50 2T 94-95, FLIPPER 50 2T 98-04, FLIPPER EURO 2 50 2T 03-03, FORTE 50 2T 94-96, MACH G 50 2T 02-04, MACH G LC 50 2T 02-04, NITRO 50 2T 97-04, NITRO EURO 2 50 2T 03-03, OVETTO 50 2T 97-04, OVETTO 4T 50 4T-3V 09-11, OVETTO EURO 2 50 2T 02-02, SORRISO 50 2T 95-96, STUNT 50 2T 00-02, TARGET 50 2T 91-95

MOTRON SYNCRO 50 2T 98-00, THUNDER 50 2T 95-98

RIEJU FIRST 50 2T 95-98, WINDY 50 2T 95-98

YAMAHA AEROX 50 2T 97-02, AEROX 50 2T 04-16, AEROX EURO 2 50 2T 03-03, AEROX NAKED 50 2T 13-16, AEROX R 50 2T 99-00, AXIS 50 2T 95-96, BREEZE 50 2T 94-95, BW'S 50 2T 97-16, BW'S BUMP 50 2T 97-98, BW'S EASY 50 2T 13-13, BW'S NAKED 50 2T 03-04, BW'S NAKED 50 2T 09-16, BW'S NEXT GENERATION 50 2T 97-06, BW'S ORIGINAL 50 2T 99-01, BW'S ORIGINAL EURO 2 50 2T 03-03, CRZ 50 2T 91-95, CT 50 2T 90-95, GIGGLE 50 4T-3V 08-08, JOG 50 2T 92-01, JOG ER 50 2T 00-02, JOG R 50 2T 02-02, JOG R EURO2 50 2T 02-02, JOG R EURO2 50 2T 06-15, JOG R LC 50 2T 02-15, JOG Z 50 2T 95-95, NEO'S 50 2T 97-02, NEO'S 50 2T 04-16, NEO'S 4 50 4T-3V 09-15, NEO'S EASY 50 2T 13-13, NEO'S EURO 2 50 2T 02-02, RS SPY 50 2T 95-98, SLIDER 50 2T 00-02, WHY 50 2T 98-05, WHY EURO 2 50 2T 03-05, ZEST 50 2T 95-92, ZUMA 50 2T 97-01



◀ cod. **9926630**
Frizione con campana Ø interno 107 mm, adattabile a tutti i motori scooter 50 cc. Gilera, Piaggio, Derbi.

APPLICABILITÀ

APRILIA MOJITO CUSTOM 2T MOTORE PIAGGIO 50 2T 04-10, SCARABEO 2T EU2 MOTORE PIAGGIO 50 2T 10-12, SCARABEO 2T NET 50 2T 09-10, SCARABEO 4T 50 4T 02-06, SCARABEO 4T 4V 50 4T-4V 10-12, SCARABEO 4T 4V NET 50 4T-4V 09-10, SCARABEO 4T RESTYLING EU3 50 4T 06-09, SCARABEO QUATTRO 50 4T-4V 09-09, SCARABEO STREET 50 2T 05-06, SCARABEO STREET 2T RESTYLING 50 2T 06-09, SPORT CITY ONE 2T 50 2T 08-11, SPORT CITY ONE 4T 50 4T 08-10, SR MOTARD 50 2T 12-14, SR R 50 2T 04-09, SR R FACTORY CARBURATORE 50 2T 10-14, SR R FACTORY IE 50 2T 10-14, SR STREET CARBURATORE 50 2T 03-12

BSV DIO GP 50 2T 94-96, DIO SP 50 2T 94-96, DIO ZX 50 2T 94-96

DERBI ATLANTIS 2T 50 2T 10-10, ATLANTIS 2T EU2 50 2T 07-09, ATLANTIS 02 50 2T 02-02, ATLANTIS 02 BULLET 50 2T 03-05, ATLANTIS 02 CITY 50 2T 04-06, ATLANTIS 02 RED BULLET 50 2T 03-03, ATLANTIS 02 TWO CHIC 50 2T 05-05, BOULEVARD 2T 50 2T 09-14, GP1 50 2T 01-03, GP1 EU 2 50 2T 05-05, GP1 OPEN EU2 50 2T 06-09, GP1 RACE EU2 50 2T 05-07, SONAR 2T 50 2T 09-09

GILERA DNA 50 2T 00-02, DNA 50 2T 05-07, DNA GP EXPERIENCE 50 2T 03-04, EASY MOVING 50 2T 95-96, ICE 50 2T 01-05, RUNNER 50 2T 97-00, RUNNER POGGIALI 50 2T 02-02, RUNNER PURE JET 50 2T-IE 02-07, RUNNER PURE JET 50 2T-IE 10-11, RUNNER PURE JET ST 50 2T-IE 08-08, RUNNER SP 50 2T 02-07, RUNNER SP 50 2T 10-12, RUNNER SP SPECIAL EDITION 50 2T 07-07, RUNNER SP ST & SIMONCELLI 50 2T 08-09, STALKER 50 2T 97-11, STALKER NAKED 50 2T 08-08, STALKER SPECIAL EDITION 50 2T 07-08, STORM 50 2T 94-95, STORM EURO 2 50 2T 07-07, TYPHOON 50 2T 94-97, TYPHOON X 50 2T 98-99, TYPHOON XR 50 2T 00-00

HONDA DIO SR 50 2T 92-00, DIO ZX 50 2T 94-96, SFX / SXR 50 2T 95-01, SGX SKY 50 2T 97-04

HSC SC 01 50 2T 94-96, SC 01 L 50 2T 94-96

ITALJET JET SET 50 2T 02-02, TORPEDO NEW 50 2T 00-01

PIAGGIO DIESIS 50 2T 01-01, FLY 2T 50 2T 05-07, FLY 2T 50 2T 10-11, FREE 50 2T 92-94, FREE DELIVERY 50 2T 00-01, FREE FL 50 2T 95-02, LIBERTY 50 2T 97-05, LIBERTY 2T 50 2T 06-08, LIBERTY 2T PTT EU2 50 2T 04-05, LIBERTY 2T RST 50 2T 04-04, LIBERTY 2T SPORT 50 2T 06-08, LIBERTY 4T 3V IE 50 4T-3V 15-17, LIBERTY 4T 3V IE E4 50 4T-3V 17-18, LIBERTY MOC 2T & ELLE 50 2T 09-13, NRG 50 2T 94-96, NRG EXTREME LC 50 2T 99-00, NRG MC3 50 2T 01-04, NRG POWER DD 50 2T 05-17, NRG POWER DD SERIE SPECIALE 50 2T 07-12, NRG POWER DT 50 2T 06-15, NRG POWER DT SERIE SPECIALE 50 2T 07-08, NRG POWER PUREJET 50 2T-IE 04-11, NRG PUREJET 50 2T-IE 02-04, NRG PUREJET 50 2T-IE 10-10, NRG RST MC2 50 2T 96-98, NTT 50 2T 95-96, QUARTZ 50 2T 92-96, SFERA 50 2T 91-93, SFERA MAQUILLAGE 2 50 2T 94-94, SFERA RST 50 2T 95-97, TYPHOON 50 2T 01-11, TYPHOON 2T E2 50 2T 10-12, TYPHOON 2T E3 CH 50 2T 11-11, VESPA ET2 50 2T 97-05, VESPA ET2 INIEZIONE 50 2T 97-00, VESPA LX 2T 50 2T 05-13, VESPA LX 2T TOURING & 30KM 50 2T 10-13, VESPA LXV 2T 50 2T 06-09, VESPA LXV 2T NAVY 50 2T 08-08, VESPA S 2T & COLLEGE 50 2T 07-12, ZIP 50 2T 92-93, ZIP 50 2T 95-96, ZIP 2T 50 2T 08-13, ZIP BIMODALE 50 2T 94-97, ZIP FAST RIDER 50 2T 93-94, ZIP FAST RIDER RST 50 2T 96-97, ZIP LC 50 2T 00-04, ZIP RST 50 2T 96-99, ZIP SP 50 2T 96-04, ZIP SP EURO 2 50 2T 06-13



cod. **9927450**

RACING

Frizione completa regolabile "TPR" (GP) Ø 107 mm, scooter 50 cc Minarelli/Yamaha
N. BREVETTO 1413380



APPLICABILITÀ

APRILIA AMICO 50 2T 94-94, AMICO 50 2T 96-98, AMICO GL/GLE 50 2T 93-95, AMICO LX/SPORT/CAT 50 2T 92-93, AREA 51 50 2T 98-00, GULLIVER 50 2T 95-98, GULLIVER LC 50 2T 96-98, RALLY 50 2T 95-03, RALLY LIQUID COOLED 50 2T 96-99, SCARABEO 50 2T 93-05, SONIC 50 2T 98-07, SONIC GP 50 2T 98-08, SR (ORIZZONTALE) 50 2T 94-96, SR (VERTICALE) 50 2T 93-93, SR LIQUID COOLED 50 2T 94-96, SR RACING 50 2T 97-99, SR STEALTH 50 2T 97-00, SR WWW 50 2T 97-01

ATALA CAROSELLO 50 2T 99-01

BENELLI 491 GT 50 2T 98-99, 491 NAKED 50 2T 02-02, 491 RACING 50 2T 98-99, 491 RR 50 2T 99-01, 491 SP 50 2T 99-99, 491 SPORT 50 2T 98-99, 491 ST 50 2T 99-01, K2 50 2T 98-01, K2 LIQUID COOLED 50 2T 98-01, PEPE 50 2T 99-01, PEPE LX 50 2T 03-04

BETA ARK 50 2T 96-08, ARK LC 50 2T 96-08, CHRONO 50 2T 95-96, EIKON 50 2T 99-03, QUADRA 50 2T 95-95, TEMPO 50 2T 93-02, TEMPO 50 2T 95-95

ITALJET BAZOOKA 50 2T 91-94, DRAGSTER 50 2T 98-02, PISTA 50 2T 92-97, PISTA 2 50 2T 97-98, SCOOOP 50 2T 91-95, SCOOOP 2 50 2T 96-98, YANKEE 50 2T 93-97

KTM K50 50 2T 96-01

MACAL THUNDER 50 2T 95-96

MALAGUTI CENTRO SL 50 2T 94-98, CIAK 50 2T 99-01, CIAK EURO 2 2,3 50 2T 03-03, CIAK EURO2 50 2T 01-03, F10 50 2T 92-00, F10 EURO 2 50 2T 02-06, F10 EURO 2,3 50 2T 03-04, F12 PHANTOM 50 2T 94-98, F12 PHANTOM EURO 2 50 2T 02-02, F12 PHANTOM EURO 2,3 50 2T 03-04, F12 PHANTOM LC 50 2T 94-98, F12 PHANTOM LC EURO 2 2,3 50 2T 03-04, F12 RESTYLING EURO 1 50 2T 99-02, F12 RESTYLING EURO 2 50 2T 06-06, F15 FIRE FOX 50 2T 96-98, F15 FIRE FOX EURO 2 50 2T 02-03, F15 FIRE FOX EURO 2,3 50 2T 03-04, YESTERDAY 50 2T 97-00

MBK BOOSTER 50 2T 90-04, BOOSTER 50 2T 90-94, BOOSTER EURO 2 50 2T 04-04, BOOSTER NG 50 2T 95-03, BOOSTER ROCKET 50 2T 97-98, BOOSTER SPIRIT 50 2T 96-00, BOOSTER SPIRIT 50 2T 03-03, BOOSTER SPIRIT EURO2 50 2T 03-03, BOOSTER TRACK 50 2T 96-98, FLIPPER EURO 2 50 2T 03-03, MACH G 50 2T 02-04, MACH G LC 50 2T 02-04, NITRO 50 2T 97-04, NITRO EURO 2 50 2T 03-03, OVETTO 50 2T 97-04, OVETTO EURO 2 50 2T 02-02, SORRISO 50 2T 95-96, STUNT 50 2T 00-02, TARGET 50 2T 91-95

MOTRON SYNCRO 50 2T 98-00, THUNDER 50 2T 95-98

RIEJU FIRST 50 2T 95-98, WINDY 50 2T 95-98

YAMAHA AEROX 50 2T 97-02, AEROX 50 2T 04-16, AEROX EURO 2 50 2T 03-03, AEROX NAKED 50 2T 13-16, AEROX R 50 2T 99-00, BW'S 50 2T 97-16, BW'S BUMP 50 2T 97-98, BW'S EASY 50 2T 13-13, BW'S NAKED 50 2T 03-04, BW'S NAKED 50 2T 09-16, BW'S NEXT GENERATION 50 2T 97-06, BW'S ORIGINAL 50 2T 99-01, BW'S ORIGINAL EURO 2 50 2T 03-03, CBZ 50 2T 91-95, CT 50 2T 90-95, JOG R 50 2T 02-02, JOG R EURO2 50 2T 02-02, JOG R EURO2 50 2T 06-15, JOG R LC 50 2T 02-15, NEO'S 50 2T 97-02, NEO'S 50 2T 04-16, NEO'S EASY 50 2T 13-13, NEO'S EURO 2 50 2T 02-02, RS SPY 50 2T 95-98, SLIDER 50 2T 00-02, WHY 50 2T 98-05, WHY EURO 2 50 2T 03-05, ZUMA 50 2T 97-01

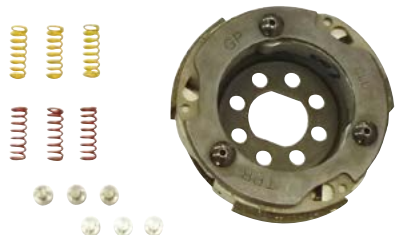

cod. **9928340**

RACING

Frizione completa regolabile "TPR" (GP) Ø 107 mm, scooter 50 cc Piaggio
N. BREVETTO 1413380



APPLICABILITÀ

APRILIA MOJITO CUSTOM 2T MOTORE PIAGGIO 50 2T 04-10, SCARABEO 2T EU2 MOTORE PIAGGIO 50 2T 10-12, SCARABEO 2T NET 50 2T 09-10, SCARABEO 4T 50 4T 02-06, SCARABEO 4T 4V 50 4T-4V 10-12, SCARABEO 4T 4V NET 50 4T-4V 09-10, SCARABEO 4T RESTYLING EU3 50 4T 06-09, SCARABEO QUATTRO 50 4T-4V 09-09, SCARABEO STREET 50 2T 05-06, SCARABEO STREET 2T RESTYLING 50 2T 06-09, SPORT CITY ONE 2T 50 2T 08-11, SPORT CITY ONE 4T 50 4T 08-10, SR MOTO 50 2T 12-14, SR R 50 2T 04-09, SR R FACTORY CARBURATORE 50 2T 10-14, SR R FACTORY IE 50 2T 10-14, SR R FACTORY IE 50 2T-IE 10-12, SR STREET CARBURATORE 50 2T 03-12

DERBI ATLANTIS 2T 50 2T 10-10, ATLANTIS 2T EU2 50 2T 07-09, ATLANTIS 4T 50 4T 04-06, ATLANTIS 4T EU2 50 4T 07-07, ATLANTIS O2 50 2T 02-02, ATLANTIS O2 BULLET 50 2T 03-05, ATLANTIS O2 CITY 50 2T 04-06, ATLANTIS O2 RED BULLET 50 2T 03-03, ATLANTIS O2 TWO CHIC 50 2T 05-05, BOULEVARD 2T 50 2T 09-14, BOULEVARD 4T EU2 25KM/H 50 4T 09-09, GP1 50 2T 01-03, GP1 EU 2 50 2T 05-05, GP1 OPEN EU2 50 2T 06-09, GP1 RACE EU2 50 2T 05-07, SONAR 2T 50 2T 09-09

GILERA DNA 50 2T 00-02, DNA 50 2T 05-07, DNA GP EXPERIENCE 50 2T 03-04, EASY MOVING 50 2T 95-96, ICE 50 2T 01-05, RUNNER 50 2T 97-00, RUNNER POGGIALI 50 2T 02-02, RUNNER PURE JET 50 2T-IE 02-07, RUNNER PURE JET 50 2T-IE 10-11, RUNNER PURE JET ST 50 2T-IE 08-08, RUNNER SP 50 2T 02-07, RUNNER SP 50 2T 10-12, RUNNER SP SPECIAL EDITION 50 2T 07-07, RUNNER SP ST &

ITALJET JET SET 50 2T 02-02, TORPEDO 50 4T 97-00, TORPEDO NEW 50 2T 00-01

MALAGUTI CENTRO EURO 2 50 4T 08-08, CENTRO SL 4T 50 4T 10-10, CIAK MASTER 4T 50 4T 05-06, CIAK MASTER EURO 2 50 4T 05-06

PIAGGIO DIESIS 50 2T 01-01, FLY 2T 50 2T 05-07, FLY 2T 50 2T 10-11, FLY 4T 50 4T 05-07, FLY 4T & 25-30 KM/H 50 4T 08-11, FLY 4T 4V 50 4T-4V 12-13, FLY 4T MOTORE CHN 50 4T 06-07, FREE 50 2T 92-94, FREE DELIVERY 50 2T 00-01, FREE FL 50 2T 95-02, LIBERTY 50 2T 97-05, LIBERTY 2T 50 2T 06-08, LIBERTY 2T PTT EU2 50 2T 04-05, LIBERTY 2T RST 50 2T 04-04, LIBERTY 2T SPORT 50 2T 06-08, LIBERTY 4T 50 4T 00-02, LIBERTY 4T 50 4T 05-08, LIBERTY 4T 3V IE 50 4T-3V 15-17, LIBERTY 4T 3V IE E4 50 4T-3V 17-18, LIBERTY 4T DELIVERY - SINGLE 50 4T 10-14, LIBERTY 4T DELIVERY TNT 50 4T 09-09, LIBERTY 4T PTT - DOUBLE - NEXIVE 50 4T 09-17, LIBERTY 4T RST 50 4T 04-04, LIBERTY 4T SPORT 50 4T 06-08, LIBERTY MOC 2T & ELLE 50 2T 09-13, LIBERTY MOC 4T & ELLE 50 4T 09-16, NRG 50 2T 94-96, NRG EXTREME LC 50 2T 99-00, NRG MC3 50 2T 01-04, NRG POWER DD 50 2T 05-17, NRG POWER DD SERIE SPECIALE 50 2T 07-12, NRG POWER DT 50 2T 06-15, NRG POWER DT SERIE SPECIALE

50 2T 07-08, NRG POWER PUREJET 50 2T-IE 04-11, NRG PUREJET 50 2T-IE 02-04, NRG PUREJET 50 2T-IE 10-10, NRG RST MC2 50 2T 96-98, NTT 50 2T 95-96, QUARTZ 50 2T 92-96, SFERA 50 2T 91-93, SFERA MAQUILLAGE 2 50 2T 94-94, SFERA RST 50 2T 95-97, TYPHOON 50 2T 01-11, TYPHOON 2T E2 50 2T 10-12, TYPHOON 2T E3 CH 50 2T 11-11, VESPA ET2 50 2T 97-05, VESPA ET2 INIEZIONE 50 2T 97-00, VESPA ET4 50 4T 00-05, VESPA LX 2T 50 2T 05-13, VESPA LX 2T TOURING & 30KM 50 2T 10-13, VESPA LX 4T 50 4T 05-09, VESPA LX 4T 4V 50 4T-4V 09-13, VESPA LX 4T 4V TOURING 50 4T-4V 10-13, VESPA LXV 2T 50 2T 06-09, VESPA LXV 2T NAVY 50 2T 08-08, VESPA S 2T & COLLEGE 50 2T 07-12, VESPA S 4T 4V & COLLEGE 50 4T-4V 08-12, ZIP 50 2T 92-93, ZIP 50 2T 95-96, ZIP 2T 50 2T 08-13, ZIP 4T 50 4T 00-13, ZIP BIMODALE 50 2T 94-97, ZIP FAST RIDER 50 2T 93-94, ZIP FAST RIDER RST 50 2T 96-97, ZIP LC 50 2T 00-04, ZIP RST 50 2T 96-99, ZIP SP 50 2T 96-04, ZIP SP EURO 2 50 2T 06-13



◀ **cod. 9927810**
Serie molle frizione rinforzate WR 125 (carico 31,5 kg)

APPLICABILITÀ

BETA	RR 125 4T-4V 10-17	MOTORHISPANIA	KN1 125 4T-4V 08-08, MH7 125 4T-4V 08-08, RX-R 125 4T-4V 08-08
FANTIC	CABALLERO MOTARD 125 4T-4V 08-18, CABALLERO REGOLARITÀ 125 4T-4V 08-08	RIEJU	MARATHON 125 4T-4V 09-09, MARATHON PRO 125 4T-4V 09-09, MARATHON PRO COMPETITION 125 4T-4V 11-11, RS3 125 4T-4V 11-11
HM	CITY 125 4T-4V 11-13, CRE F125X 125 4T-4V 08-09, CRE F125X BAJA 125 4T-4V 10-12, CRE F125X BAJA RR 125 4T-4V 10-12, CRE F125X SIX 125 4T-4V 10-11, CRM F125X 125 4T-4V 08-09, CRM F125X DERAPAGE 125 4T-4V 10-12, CRM F125X DERAPAGE COMPETITION 125 4T-4V 10-11, CRM F125X DERAPAGE RR 125 4T-4V 10-12, LOCUSTA 125 4T-4V 11-13, CITY 200 4T-4V 11-13, LOCUSTA 200 4T-4V 11-13	VENT	BAJA 125 4T-4V 18-19, BAJA RR 125 4T-4V 18-19, DERAPAGE 125 4T-4V 18-19, DERAPAGE RR 125 4T-4V 18-19, TRAIL 125 4T-4V 18-19
HUSQVARNA	SM 125 4T-4V 10-10, TE 125 4T-4V 10-10	YAMAHA	MT 125 4T 4V IE 15-15, MT A 125 4T 4V IE 15-15, WR-R IE 125 4T 4V IE 09-11, WR-X IE 125 4T 4V IE 09-11, WR-X IE 125 4T 4V IE 13-14, YZF-R A IE 125 4T 4V IE 15-15, YZF-R IE 125 4T 4V IE 08-15



◀ **cod. 9928150** **RACING**
Serie dischi frizione con molle Racing Yamaha T-Max

APPLICABILITÀ

YAMAHA	T-MAX 4BS 500 4T 09-11, T-MAX 4BS ABS 500 4T 08-11, T-MAX 5GJ 500 4T 01-03, T-MAX 5VU 500 4T 04-08, T-MAX 5VU ABS 500 4T 05-07, T-MAX 5VU BLACK MAX 500 4T 06-06, T-MAX 5VU BLACK MAX - NIGHT MAX 500 4T 07-07
---------------	--

RICAMBI

9927930	Serie molle frizione carico differenziato Yamaha T-Max
---------	--

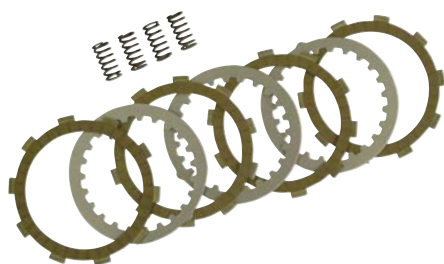

◀ **cod. 9930850** **RACING**
Serie dischi frizione "TPR" per AM 345/6

A RICAMBIO PER

9931900	Kit frizione completo Tamburo+dischi "TPR" per am 345/6
---------	---

RICAMBI

9920580	Serie molle frizione AM rinforzate 100 kg
---------	---

APPLICABILITÀ

APRILIA	CLASSIC 50 2T 92-99, EUROPA 50 2T 91-92, MX 50 2T 04-04, MX MOTARD 50 2T 95-03, PEGASO 50 2T 92-94, RS 50 2T 91-05, RX 50 2T 03-04, RX 3-5 MARCE 50 2T 91-94, RX ENDURO 50 2T 95-03, RX RACING 50 2T 03-06, TUONO 50 2T 03-04	HM	BAJA, DERAPAGE BASIC 50 2T 10-11, CMC 50 2T 10-11, CRE BAJA RR, DERAPAGE RR 50 2T 07-11, CRE BAJA, DERAPAGE 50 2T 07-11, CRE SIX COMPETITION 50 2T 10-11, CRE SIX, BAJA, DERAPAGE 50 2T 95-06, CRE SIX, DERAPAGE COMPETITION 50 2T 07-09, DERAPAGE COMPETITION 50 2T 10-11	RIEJU	MRT 50 2T 09-12, MRT 50 EU4 50 2T 18-20, MRT PRO 50 2T 09-12, MRT PRO EU4 50 2T 18-20, MRT PRO REPLICA EU4 50 2T 18-20, MRT PRO REPLICA SM EU4 50 2T 18-20, MRT PRO SM 50 2T 09-12, MRT PRO SM EU4 50 2T 18-20, MRT SM 50 2T 09-12, MRT SM EU4 50 2T 18-20, MRT TROPHY EU4 50 2T 18-20, MRX 50 2T 01-04, MRX PRO 50 2T 01-04, RR 50 2T 05-06, RS1 50 2T 98-01, RS2 MATRIX 50 2T 05-06, RS2 MATRIX PRO 50 2T 05-06, RS2 NAKED 50 2T 04-05, RS3 EU4 50 2T 18-20, RS3 NKD EU4 50 2T 18-20, SMX E.S./K.S. 50 2T 01-01, SMX PRO E.S./K.S. 50 2T 03-03, SPIKE 50 2T 98-01
BETA	RR 2T 50 EU4 50 2T 18-20, RR 50 RACING EU4 50 2T 18-20, RR ALU 50 2T 08-12, RR ENDURO 50 2T 06-17, RR MOTARD 50 2T 06-17	MALAGUTI	CNK DRAGON 50 2T 05-07, FIFTY EVOLUTION 50 2T 90-93, XSM 50 2T 03-03, XTM 50 2T 03-03	SHERCO	FACTORY SE-R EU4 50 2T 18-20, FACTORY SE-RS EU4 50 2T 18-20, FACTORY SILVER SM-R EU4 50 2T 18-20, FACTORY SILVER SM-RS EU4 50 2T 18-20, FACTORY SM-R EU4 50 2T 18-20, FACTORY SM-RS EU4 50 2T 18-20, HRD ENDURO 50 2T 09-13, HRD MOTARD 50 2T 09-13
CH	SM 50 2T 00-10, WR 50 2T 00-10, WSM 50 2T 00-10	MBK	X LIMIT 50 2T 03-04, X POWER 50 2T 03-04	VENT	BAJA 50 2T 18-20, BAJA RR 50 2T 18-20, DERAPAGE 50 2T 18-20, DERAPAGE RR 50 2T 18-20
HUSQUARNA		MINARELLI	MOTORE AM 3-4-5 50 2T 91-95, MOTORE AM 6 1° SERIE 50 2T 96-11, MOTORE AM 6 2° SERIE 50 2T 12-18	YAMAHA	DT R 50 2T 03-11, DT RSM 50 2T 03-05, DT X 50 2T 06-11, TZR 50 2T 03-08, TZR 50 2T 10-11, TZR RR 50 2T 05-05
CMC	ENDURO 50 2T 11-11, MOTARD 50 2T 11-11	MOTORHISPANIA	FURIA 50 2T 97-00, FURIA MAX 50 2T 10-12, RX 50 2T 09-12, RX R 50 2T 09-12		
FANTIC	CABALLERO MOTARD 50 2T 06-10, CABALLERO REGOLARITÀ 50 2T 06-10, ENDURO COMPETITION EU4 50 2T 18-20, ENDURO PERFORMANCE EU4 50 2T 18-20, MOTARD COMPETITION EU4 50 2T 18-20, MOTARD PERFORMANCE EU4 50 2T 18-20	PEUGEOT	SUPERMOTARD 50 2T 90-02, XP6 TRAIL S/AVV. ELETTRICO 50 2T 90-02, XR6 RACING CAT. C/AVV.ELETT. 50 2T 90-02		



cod. **9930880**

RACING

Serie dischi frizione con molle Racing Yamaha T-Max 530/560

APPLICABILITÀ

YAMAHA T-MAX 59C 530 4T 12-16, T-MAX 59C ABS 530 4T 12-16, T-MAX 59C SP 530 4T 15-15, T-MAX 59C SP ABS 530 4T 15-16, XP530-A T-MAX SX 530 4T 17-19, XP530D-A T-MAX DX 530 4T 17-19, XP530E-A T-MAX 530 4T 17-18

RICAMBI

9930890	Serie molle frizione
---------	----------------------

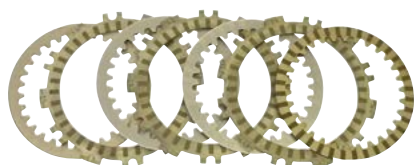

cod. **9931020**

Serie dischi frizione con molle Piaggio 350 cc

APPLICABILITÀ

PIAGGIO BEVERLY 4T 4V IE EU3 350 4T 11-14, BEVERLY 4T ST IE ABS 350 4T 16-16, X10 4T 4V IE EURO3 350 4T 12-15

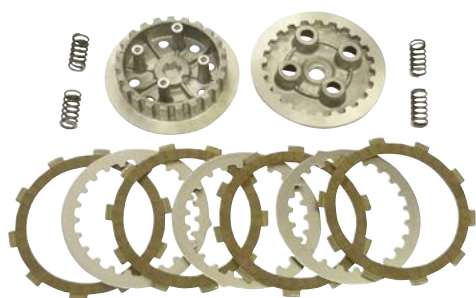

cod. **9931900**

RACING

Kit frizione completa tamburo e dischi "TPR" per AM 345/6

APPLICABILITÀ

APRILIA	CLASSIC 50 2T 92-99, EUROPA 50 2T 91-92, MX 50 2T 04-04, MX MOTARD 50 2T 95-03, PEGASO 50 2T 92-94, RS 50 2T 91-05, RX 50 2T 03-04, RX 3-5 MARCE 50 2T 91-94, RX ENDURO 50 2T 95-03, RX RACING 50 2T 03-06, TUONO 50 2T 03-04	MINARELLI	MOTORE AM 3-4-5 50 2T 91-95, MOTORE AM 6 1° SERIE 50 2T 96-11, MOTORE AM 6 2° SERIE 50 2T 12-18
BETA	RR 2T 50 EU4 50 2T 18-20, RR 50 RACING EU4 50 2T 18-20, RR ALU 50 2T 08-12, RR ENDURO 50 2T 06-17, RR MOTARD 50 2T 06-17	MOTORHISPANIA	FURIA 50 2T 97-00, FURIA MAX 50 2T 10-12, RX 50 2T 09-12, RX R 50 2T 09-12
CH HUSQUARNA CMC	SM 50 2T 00-10, WR 50 2T 00-10, WSM 50 2T 00-10	PEUGEOT	SUPERMOTARD 50 2T 90-02, XP6 TRAIL S/AVV. ELETTRICO 50 2T 90-02, XR6 RACING CAT. C/AVV.ELETT. 50 2T 90-02
FANTIC	CABALLERO MOTARD 50 2T 06-10, CABALLERO REGOLARITÀ 50 2T 06-10, ENDURO COMPETITION EU4 50 2T 18-20, ENDURO PERFORMANCE EU4 50 2T 18-20, MOTARD COMPETITION EU4 50 2T 18-20, MOTARD PERFORMANCE EU4 50 2T 18-20	RIEJU	MRT 50 2T 09-12, MRT 50 EU4 50 2T 18-20, MRT PRO 50 2T 09-12, MRT PRO EU4 50 2T 18-20, MRT PRO REPLICA EU4 50 2T 18-20, MRT PRO REPLICA SM EU4 50 2T 18-20, MRT PRO SM 50 2T 09-12, MRT PRO SM EU4 50 2T 18-20, MRT SM 50 2T 09-12, MRT SM EU4 50 2T 18-20, MRT TROPHY EU4 50 2T 18-20, MRX 50 2T 01-04, MRX PRO 50 2T 01-04, RR 50 2T 05-06, RS1 50 2T 98-01, RS2 MATRIX 50 2T 05-06, RS2 MATRIX PRO 50 2T 05-06, RS2 NAKED 50 2T 04-05, RS3 EU4 50 2T 18-20, RS3 NKD EU4 50 2T 18-20, SMX E.S./K.S. 50 2T 01-01, SMX PRO E.S./K.S. 50 2T 03-03, SPIKE 50 2T 98-01
HM	BAJA, DERAPAGE BASIC 50 2T 10-11, CMC 50 2T 10-11, CRE BAJA RR, DERAPAGE RR 50 2T 07-11, CRE BAJA, DERAPAGE 50 2T 07-11, CRE SIX COMPETITION 50 2T 10-11, CRE SIX, BAJA, DERAPAGE 50 2T 95-06, CRE SIX, DERAPAGE COMPETITION 50 2T 07-09, DERAPAGE COMPETITION 50 2T 10-11	SHERCO	FACTORY SE-R EU4 50 2T 18-20, FACTORY SE-RS EU4 50 2T 18-20, FACTORY SILVER SM-R EU4 50 2T 18-20, FACTORY SILVER SM-RS EU4 50 2T 18-20, FACTORY SM-R EU4 50 2T 18-20, FACTORY SM-RS EU4 50 2T 18-20, HRD ENDURO 50 2T 09-13, HRD MOTARD 50 2T 09-13
MALAGUTI	CNK DRAGON 50 2T 05-07, FIFTY EVOLUTION 50 2T 90-93, XSM 50 2T 03-03, XTM 50 2T 03-03	VENT	BAJA 50 2T 18-20, BAJA RR 50 2T 18-20, DERAPAGE 50 2T 18-20, DERAPAGE RR 50 2T 18-20
MBK	X LIMIT 50 2T 03-04, X POWER 50 2T 03-04	YAMAHA	DT R 50 2T 03-11, DT RSM 50 2T 03-05, DT X 50 2T 06-11, TZR 50 2T 03-08, TZR 50 2T 10-11, TZR RR 50 2T 05-05

RICAMBI

9920580	Serie Molle Frizione Am Rinforz. 100 Kg.
---------	--

9930850	Serie Dischi Friz."TPR" Per Am345/6
---------	-------------------------------------



◀ **cod. 9927100**

Gruppo termico Ø 39,885 Derbi Senda (d50b0) motore Piaggio

Cilindro in ghisa Minacrom con 7 travasi | Cilindrata 49,93 cc - Corsa mm 40 - Rapp. Comp. 1:13,8 | Completo di testa

RICAMBI

9927000	Pistone completo Ø 39,88
9927001	Pistone completo Ø 40,28
9930230	Serie segmenti Ø39,88
9930231	Serie segmenti Ø 40,28
9930240	Serie guarnizioni

9930220	Testa
9928090	Raccordo testa
9929480	Serie prigionieri M7 x 115
9930270	Tappo cilindrico

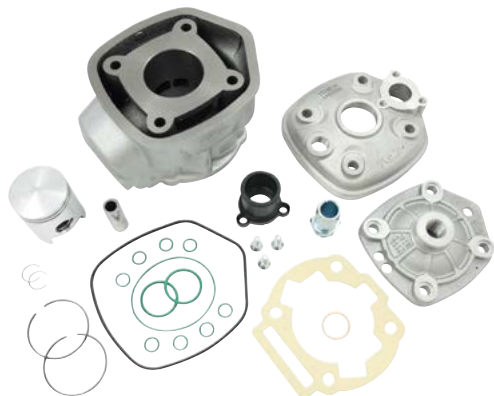

◀ **cod. 9927980**

Gruppo Termico Ø 39,88 Motore Derbi Senda (EBS050)

RICAMBI

9927000	Pistone completo Ø 39,885
9930230	Serie segmenti Ø 39,885
9930231	Serie segmenti Ø 40,28
9930260	Serie guarnizioni Ø 39,885

9930250	Testa completa Ø 39,885
9928050	Raccordo testa Ø 39,885
9929960	Raccordo cilindro Ø 39,885



◀ **cod. 9914500**

Gruppo termico Ø 40 adattabile a motori Gilera/Piaggio air cooled

Cilindro in ghisa Minacrom con 5 travasi | Cilindrata 49,3 cc - Corsa mm 39,3 - Rapp. Comp. 1:12 | Completo di testa

RICAMBI

9913470	Pistone completo Ø 40
9913471	Pistone completo Ø 40,5
9913472	Pistone completo Ø 41
9910380	Serie segmenti Ø 40

9910381	Serie segmenti Ø 40,5
9914710	Guarnizione base
9910750	Testa troncoconica



◀ **cod. 9916580**

Gruppo termico Ø 40 adattabile a motori Gilera/Piaggio liquid cooled con raccordo testa

Cilindro in ghisa Minacrom con 5 travasi | Cilindrata 49,3 cc - Corsa mm 39,3 - Rapp. Comp. 1:13,5 | Completo di testa

RICAMBI

9913470	Pistone completo Ø 40
9913471	Pistone completo Ø 40,5
9913472	Pistone completo Ø 41
9910380	Serie segmenti Ø 40

9910381	Serie segmenti Ø 40,5
9914270	Serie guarnizioni
9916570	Testa troncoconica



◀ **cod. 9924770**

Gruppo termico Ø 40 adattabile a motori Peugeot air cooled "EU2"

Cilindro in ghisa Minacrom con 7 travasi | Cilindrata 49,1 cc - Corsa mm 39,1 - Rapp. Comp. 1:12 | Completo di testa

RICAMBI

9913370	Pistone completo Ø 40
9913371	Pistone completo Ø 40,5
9910380	Serie segmenti Ø 40

9910381	Serie segmenti Ø 40,5
9914720	Guarnizione base
9910760	Testa

ATTENZIONE: QUESTI PRODOTTI SONO DESTINATI ESCLUSIVAMENTE AD USO AGONISTICO. NE È QUINDI VIETATO L'UTILIZZO SU STRADA PUBBLICA.

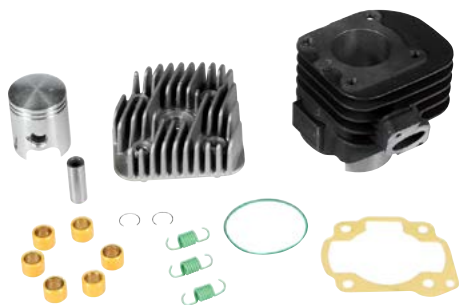

◀ cod. **9925650**

Gruppo termico Ø 40 per Keeway Focus

Cilindro in ghisa Minacrom con 6 travasi | Cilindrata 49,24 cc - Corsa mm 39,2 - Rapp. Comp. 1:12,2 | Completo di testa

RICAMBI

9927210	Pistone completo Ø 40
9927211	Pistone completo Ø 40,5
9910380	Serie segmenti Ø 40

9910381	Serie segmenti Ø 40,5
9927220	Serie guarnizioni
9915880	Testa



◀ cod. **9925830**

Gruppo termico Ø 40 per Peugeot Ludix 50 cc

Cilindro in ghisa Minacrom con 6 travasi | Cilindrata 49,98 cc - Corsa mm 39,8 - Rapp. Comp. 1:12,9 | Completo di testa

RICAMBI

9913370	Pistone completo Ø 40
9913371	Pistone completo Ø 40,5
9910380	Serie segmenti Ø 40

9910381	Serie segmenti Ø 40,5
9927880	Serie guarnizioni
9927470	Testa



◀ cod. **9931110**

Gruppo termico Black Trophy Ø 40 Liquid Cooled per motori scooter 50 cc Minarelli/Yamaha

Cilindro in ghisa Minacrom con 7 travasi | Cilindrata 49,2 cc - Corsa mm 39,2 - Rapp. Compr. 1:13 | Completo di testa

RICAMBI

9931130	Pistone completo MoS2 Ø 40
9910431	Pistone completo Ø 40,5
9910380	Serie segmenti Ø 40

9910381	Serie segmenti Ø 40,5
9915910	Serie guarnizioni
9915890	Testa



◀ cod. **9931140**

Gruppo termico Black Trophy Ø 40 Air Cooled per motori scooter 50 cc Minarelli/Yamaha orizzontale

Cilindro in ghisa Minacrom con 7 travasi | Cilindrata 49,2 cc - Corsa mm 39,2 - Rapp. Comp. 1:13 | Completo di testa

RICAMBI

9931130	Pistone completo MoS2 Ø 40
9910431	Pistone completo Ø 40,5
9910380	Serie segmenti Ø 40

9910381	Serie segmenti Ø 40,5
9915900	Serie guarnizioni
9915880	Testa



◀ cod. **9931170**

Gruppo termico Black Trophy Ø 40 Air Cooled per motori scooter 50 cc Minarelli/Yamaha verticale

Cilindro in ghisa Minacrom con 7 travasi | Cilindrata 49,2 cc - Corsa mm 39,2 - Rapp. Comp. 1:13 | Completo di testa

RICAMBI

9931130	Pistone completo MoS2 Ø 40
9910431	Pistone completo Ø 40,5
9910380	Serie segmenti Ø 40

9910381	Serie segmenti Ø 40,5
9916530	Serie guarnizioni
9916520	Testa

ATTENZIONE: QUESTI PRODOTTI SONO DESTINATI ESCLUSIVAMENTE AD USO AGONISTICO. NE È QUINDI VIETATO L'UTILIZZO SU STRADA PUBBLICA.



◀ **cod. 9934200**

Gruppo termico Ø 40 spinotto Ø 12 motori scooter 50 cc Minarelli/Yamaha

APPLICABILITÀ

Malaguti F10 AC ECO 50 2T 09-10, F12 R PHANTOM AC 50 2T 09-10

RICAMBI

9927210	Pistone completo
9910380	Serie segmenti
9927220	Serie guarnizioni
9915880	Testa



◀ **cod. 9916770**

Gruppo termico Ø 40,3 adattabile a motori Minarelli AM6 EU1 AM345/AM6

Cilindro in ghisa Minacrom 5 travasi | Cilindrata 49,7 cc - Corsa mm. 39 - Rapp. Comp. 1:12 | Completo di testa

RICAMBI

9915610	Pistone completo Ø 40,3
9915611	Pistone completo Ø 40,6
9915612	Pistone completo Ø 40,8
9915620	Serie segmenti Ø 40,3

9915621	Serie segmenti Ø 40,6
9915622	Serie segmenti Ø 40,8
9915630	Serie guarnizioni
9916800	Testa



◀ **cod. 9934500**

Gruppo Termico in alluminio Ø 40,3 "TPR" per AM6

APPLICABILITÀ

APRILIA CLASSIC 50 2T 92-99, EUROPA 50 2T 91-92, MX 50 2T 04-04, MX MOTARD 50 2T 95-03, PEGASO 50 2T 92-94, RS 50 2T 91-05, RX 50 2T 03-04, RX 3-5 MARCE 50 2T 91-94, RX ENDURO 50 2T 95-03, RX RACING 50 2T 03-06, TUONO 50 2T 03-04

BETA RR 2T 50 EU4 50 2T 18-20, RR 50 RACING EU4 50 2T 18-20, RR ALU 50 2T 08-12, RR ENDURO 50 2T 06-17, RR MOTARD 50 2T 06-17

CH HU-SM 50 2T 00-10, WR 50 2T 00-10, WSM 50 2T 00-10

SQUARNA

CMC ENDURO 50 2T 11-11, MOTARD 50 2T 11-11

FANTIC CABALLERO MOTARD 50 2T 06-10, CABALLERO REGOLARITÀ 50 2T 06-10, ENDURO COMPETITION EU4 50 2T 18-20, ENDURO PERFORMANCE EU4 50 2T 18-20, MOTARD COMPETITION EU4 50 2T 18-20, MOTARD PERFORMANCE EU4 50 2T 18-20

HM BAJA, DERAPAGE BASIC 50 2T 10-11, CMC 50 2T 10-11, CRE BAJA RR, DERAPAGE RR 50 2T 07-11, CRE BAJA, DERAPAGE 50 2T 07-11, CRE SIX COMPETITION 50 2T 10-11, CRE SIX, BAJA, DERAPAGE 50 2T 95-06, CRE SIX, DERAPAGE COMPETITION 50 2T 07-09, DERAPAGE COMPETITION 50 2T 10-11

MALAGUTI CNK DRAGON 50 2T 05-07, FIFTY EVOLUTION 50 2T 90-93, XSM 50 2T 03-03, XTM 50 2T 03-03

MBK X LIMIT 50 2T 03-04, X POWER 50 2T 03-04

MINARELLI MOTORE AM 3-4-5 50 2T 91-95, MOTORE AM 6 1° SERIE 50 2T 96-11, MOTORE AM 6 2° SERIE 50 2T 12-18

MOTORHISPANIA FURIA 50 2T 97-00, FURIA MAX 50 2T 10-12, RX 50 2T 09-12, RX R 50 2T 09-12

PEUGEOT SUPERMOTARD 50 2T 90-02, XP6 TRAIL S/AVV. ELETTRICO 50 2T 90-02, XR6 RACING CAT. C/AVV.ELETT. 50 2T 90-02

RIEJU MRT 50 2T 09-12, MRT 50 EU4 50 2T 18-20, MRT PRO 50 2T 09-12, MRT PRO EU4 50 2T 18-20, MRT PRO REPLICA EU4 50 2T 18-20, MRT PRO REPLICA SM EU4 50 2T 18-20, MRT PRO SM 50 2T 09-12, MRT PRO SM EU4 50 2T 18-20, MRT SM 50 2T 09-12, MRT SM EU4 50 2T 18-20, MRT TROPHY EU4 50 2T 18-20, MRX 50 2T 01-04, MRX PRO 50 2T 01-04, RR 50 2T 05-06, RS1 50 2T 98-01, RS2 MATRIX 50 2T 05-06, RS2 MATRIX PRO 50 2T 05-06, RS2 NAKED 50 2T 04-05, RS3 EU4 50 2T 18-20, RS3 NKO EU4 50 2T 18-20, SMX E.S./K.S. 50 2T 01-01, SMX PRO E.S./K.S. 50 2T 03-03, SPIKE 50 2T 98-01

SHERCO FACTORY SE-R EU4 50 2T 18-20, FACTORY SE-RS EU4 50 2T 18-20, FACTORY SILVER SM-R EU4 50 2T 18-20, FACTORY SILVER SM-RS EU4 50 2T 18-20, FACTORY SM-R EU4 50 2T 18-20, FACTORY SM-RS EU4 50 2T 18-20, HRD ENDURO 50 2T 09-13, HRD MOTARD 50 2T 09-13

VENT BAJA 50 2T 18-20, BAJA RR 50 2T 18-20, DERAPAGE 50 2T 18-20, DERAPAGE RR 50 2T 18-20

YAMAHA DT R 50 2T 03-11, DT RSM 50 2T 03-05, DT X 50 2T 06-11, TZR 50 2T 03-08, TZR 50 2T 10-11, TZR RR 50 2T 05-05

ATTENZIONE: QUESTI PRODOTTI SONO DESTINATI ESCLUSIVAMENTE AD USO AGONISTICO. NE È QUINDI VIETATO L'UTILIZZO SU STRADA PUBBLICA.



◀ cod. **9926330**

Gruppo termico Ø 44 per Yamaha Giggie 50 cc 4T
Cilindro in alluminio | Cilindrata 64,28 cc - Corsa mm 43,6 - Rapp. Comp. 1:12

RICAMBI

992634A	Pistone completo Ø 44
992634B	Pistone completo Ø 44
992634C	Pistone completo Ø 44
9926360	Serie segmenti Ø 44

9926350	Serie guarnizioni
9926290	Spinotto + anellini
9928060	Centralina TFI programmata
9928070	Cablaggio TFI



◀ cod. **9934300**

Gruppo termico Ø 47 spinotto Ø 12 motori scooter 50 cc Minarelli/Yamaha

APPLICABILITÀ

Malaguti F10 AC ECO 50 2T 09-10, F12 R PHANTOM AC 50 2T 09-10

RICAMBI

9925250	Pistone completo
9906052	Serie segmenti
9925260	Serie guarnizioni
9906470	Testa



◀ cod. **9908660**

Gruppo termico Ø 47 per motori Peugeot Air Cooled
Cilindro in ghisa Minacrom con 5 travasi | Cilindrata 67,8 cc - Corsa mm 39,1 - Rapp. Comp. 1:11,5 | Completo di testa
Pistone con riporto di stagno

RICAMBI

9915030	Pistone completo Ø 47
9915031	Pistone completo Ø 47,5
9910410	Serie segmenti Ø 47

9910310	Serie guarnizioni
9910400	Testa



◀ **cod. 9919540**

Gruppo termico Ø 47 per motori Peugeot Speedfight liquid cooled
Cilindro in ghisa Minacrom | Cilindrata 69,98 cc - Corsa mm. 39,2 - Rapp. Comp. 1:13 | Completo di testa

RICAMBI

9915030	Pistone completo Ø 47
9915031	Pistone completo Ø 47,4
9910410	Serie segmenti Ø 47

9910412	Serie segmenti Ø 47,4
9920210	Serie guarnizioni
9919590	Testa



◀ **cod. 9924890**

Gruppo termico Ø 47 Keeway - CPI
Cilindro in ghisa Minacrom con 6 travasi | Cilindrata 67,97 cc - Corsa mm 39,2 - Rapp. Comp. 1:12,5 | Completo di testa

RICAMBI

9925250	Pistone completo Ø 47
9925251	Pistone completo Ø 47,4
9906052	Serie segmenti Ø 47

9906054	Serie segmenti Ø 47,4
9925260	Serie guarnizioni
9906470	Testa



◀ **cod. 9925800**

Gruppo termico Ø 47 per Peugeot Ludix 50 cc
Cilindro in ghisa Minacrom con 6 travasi | Cilindrata 69,01 cc - Corsa mm 39,8 - Rapp. Comp. 1:12,7 | Completo di testa

RICAMBI

9915030	Pistone completo Ø 47
9915031	Pistone completo Ø 47,4
9910410	Serie segmenti Ø 47

9910412	Serie segmenti Ø 47,4
9927890	Serie guarnizioni
9910400	Testa



◀ **cod. 9931310**

Gruppo termico Black Trophy Ø 47 Liquid Cooled per motori scooter 50 cc Minarelli/Yamaha
Cilindro in ghisa Minacrom con 8 travasi | Cilindrata 68 cc - Corsa mm 39,2 - Rapp. Comp.: 1:13 | Completo di testa

RICAMBI

9931330	Pistone completo MoS2 Ø 47
9906044	Pistone completo Ø 47,4
9906052	Serie segmenti Ø 47
9906054	Serie segmenti Ø 47,4

9910060	Serie guarnizioni
9909540	Testa
9910050	Accessori Testa

ATTENZIONE: QUESTI PRODOTTI SONO DESTINATI ESCLUSIVAMENTE AD USO AGONISTICO. NE È QUINDI VIETATO L'UTILIZZO SU STRADA PUBBLICA.



cod. 9931340

Gruppo termico Black Trophy Ø 47 Air Cooled per motori scooter 50 cc Minarelli/Yamaha orizzontale
Cilindro in ghisa Minacrom con 5 travasi | Cilindrata 68 cc – Corsa mm 39,2 – Rapp. Comp. 1:12,5 | Completo di testa

RICAMBI

9931330	Pistone completo MoS2 Ø 47
9906044	Pistone completo Ø 47,4
9906052	Serie segmenti Ø 47

9906054	Serie segmenti Ø 47,4
9907060	Serie guarnizioni
9906470	Testa



cod. 9931370

Gruppo termico Black Trophy Ø 47 Air Cooled per motori scooter 50 cc Minarelli/Yamaha verticale
Cilindro in ghisa Minacrom con 5 travasi | Cilindrata 68 cc – Corsa mm 39,2 – Rapp. Comp. 1:12,5 | Completo di testa

RICAMBI

9931330	Pistone completo MoS2 Ø 47
9906044	Pistone completo Ø 47,4
9906052	Serie segmenti Ø 47

9906054	Serie segmenti Ø 47,4
9906760	Serie guarnizioni
9907490	Testa



cod. 9931250

Gruppo termico Black Trophy Ø 48 Air Cooled per motori Piaggio 50 cc
Cilindro in ghisa Minacrom con 6 travasi | Cilindrata 71 cc – Corsa mm 39,3 – Rapp. Comp. 1:12,3 | Completo di testa

RICAMBI

9931230	Pistone completo MoS2 Ø 48
9933411	Pistone completo Ø 48,5
9931240	Serie segmenti Ø 48

9931241	Serie segmenti Ø 48,5
9908180	Serie guarnizioni
9913110	Testa



cod. 9931270

Gruppo termico Black Trophy Ø 48 Liquid Cooled per motori Piaggio 50 cc con raccordo
Cilindro in ghisa Minacrom con 6 travasi | Cilindrata 71 cc – Corsa mm 39,3 – Rapp. Comp.: 1:12 | Completo di testa

RICAMBI

9931230	Pistone completo MoS2 Ø 48
9933411	Pistone completo Ø 48,5
9931240	Serie segmenti Ø 48
9931241	Serie segmenti Ø 48,5

9914270	Serie guarnizioni
9912640	Testa
9915950	Raccordo per testa



◀ cod. **9919250**

Gruppo termico Ø 49 per motori Minarelli AM6 EU1 AM345/6

Cilindro in ghisa Minacrom 5 travasi | Cilindrata 73,5 cc - Corsa mm. 39 - Rapp. Comp. 1:12,5 | Completo di testa

RICAMBI

9906830	Pistone completo Ø 49
9906831	Pistone completo Ø 49,5
9906840	Serie segmenti Ø 49
9906841	Serie segmenti Ø 49,5

9907070	Serie guarnizioni
9906670	Testa
9906600	Spinotto



◀ cod. **9925150**

Gruppo termico Ø 49 per Piaggio 50 cc 4T

Cilindro in ghisa Minacrom | Cilindrata 78,78 cc - Corsa mm 41,8 - Rapp. Comp. 1:12

RICAMBI

9925490	Pistone completo Ø 49
9925491	Pistone completo Ø 49,5
9925550	Serie segmenti Ø 49

9925551	Serie segmenti Ø 49,5
9925570	Serie guarnizioni



◀ cod. **9928300**

Gruppo termico Ø 49 per Piaggio 4T 4V

Cilindro in ghisa Minacrom | Cilindrata 78,78 cc - Corsa mm 41,8 - Rapp. Comp. 1:12

RICAMBI

9925490	Pistone completo Ø 49
9925491	Pistone completo Ø 49,5
9925550	Serie segmenti Ø 49

9925551	Serie segmenti Ø 49,5
9928280	Serie guarnizioni



◀ cod. **9925140**

Gruppo termico Ø 50 per Kymco 50 cc 4T

Cilindro in ghisa Minacrom | Cilindrata 81,25 cc - Corsa mm 41,4 - Rapp. Comp. 1:12

RICAMBI

9925500	Pistone completo Ø 50
9925501	Pistone completo Ø 50,5
9925560	Serie segmenti Ø 50

9925561	Serie segmenti Ø 50,5
9925580	Serie guarnizioni

ATTENZIONE: QUESTI PRODOTTI SONO DESTINATI ESCLUSIVAMENTE AD USO AGONISTICO. NE È QUINDI VIETATO L'UTILIZZO SU STRADA PUBBLICA.

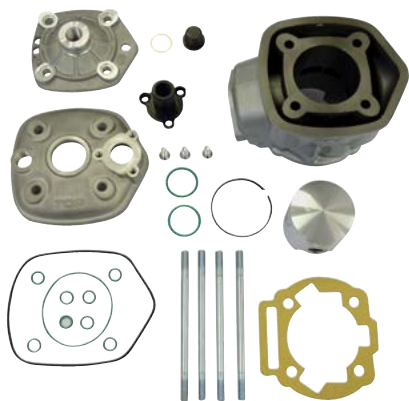

cod. 9927020

Gruppo termico Ø 50 per Derbi Senda (d50b0) motore Piaggio

Cilindro in ghisa Minacrom con 7 travasi | Cilindrata 78 cc - Corsa mm 40 - Rapp. Comp. 1:14 | Completo di testa

RICAMBI

9927010	Pistone completo Ø 50
9927011	Pistone completo Ø 50,4
9924150	Segmento Ø 50
9924151	Segmento Ø 50,4
9930240	Serie guarnizioni

9930280	Testa
9928090	Raccordo testa
9929480	Serie prigionieri M7 x 115
9930270	Tappo cilindrico
9924250	Spinotto + anellini



cod. 9928030

Gruppo Termico Ø 50 Motore Derbi Senda (Ebs050)

APPLICABILITÀ

DERBI GPR NUDE 50 2T 04-05, GPR R 50 2T 97-00, GPR RACING 50 2T 04-05, GPR REPLICA 50 2T 99-01, GPR REPLICA RACING 50 2T 02-03, GPR REPLICA RACING EU2 50 2T 05-05, SENDA BLACK EDITION 50 2T 03-03, SENDA R 50 2T 99-01, SENDA R DRD BLACK DEVIL 2A EDIZIONE 50 2T 03-03, SENDA R DRD EU1 EU1R 50 2T 02-02, SENDA R DRD RACING 50 2T 04-05, SENDA R DRD RACING LTD 50 2T 05-05, SENDA R RACER 50 2T 03-03, SENDA R X-RACE 50 2T 04-05, SENDA R X-TREME 50 2T 03-03, SENDA R X-TREME 50 2T 05-05, SENDA R X-TREME EU2 50 2T 04-04, SENDA SM 50 2T 00-01, SENDA SM DRD EDITION BLACK 50 2T 05-05, SENDA SM DRD EU1 EU1R 50 2T 02-03, SENDA SM DRD RACING 50 2T 04-05, SENDA SM DRD RACING LTD 50 2T 05-05, SENDA SM X-RACE 50 2T 04-05, SENDA SM X-TREME 50 2T 02-03, SENDA SM X-TREME EU2 50 2T 04-04, SENDA SM X-TREME EU2 2A EDIZIONE 50 2T 05-05

GILERA GSM 50 2T 01-01, RCR 50 2T 03-03, SMT 50 2T 03-03

RICAMBI

9927011	Pistone completo Ø 50,4
9927010	Pistone completo Ø 50
9924151	Segmento Ø 50,4
9924150	Segmento Ø 50
9930260	Serie guarnizioni Ø 39,885

9930320	Testa Ø 50
9928050	Raccordo testa Ø 39,885
9929960	Raccordo cilindro Ø 39,885
9924250	Spinotto + anellini



cod. 9911090

Kit di trasformazione raffreddamento da aria ad acqua per motori Minarelli/Yamaha tipo orizzontale

Parte termica standard e pompa per il raffreddamento forzato, completa di dispositivi per la sua applicazione

RICAMBI

9931330	Pistone completo Ø 47
9931331	Pistone completo Ø 47,4
9906052	Serie segmenti Ø 47
9906054	Serie segmenti Ø 47,4
9910060	Serie guarnizioni

9905910	Spinotto
9909540	Testa
9911080	Coperchio volano completo
9931310	Gruppo termico Ø 47 Black Trophy
9910050	Accessori per testa



◀ cod. **9925180**

Kit gruppo termico Ø 63 con centralina per Yamaha X-MAX 125 cc 4T
Cilindro in alluminio | Cilindrata 182,67 cc - Corsa mm 58,6 - Rapp. Comp. 1:11,5 | Completo di testa

RICAMBI

992539A	Pistone completo Ø 63
992539B	Pistone completo Ø 63
992539C	Pistone completo Ø 63
9925400	Serie segmenti Ø 63
9925590	Serie guarnizioni

9926720	Cablaggio per centralina TFI
9926710	Centralina TFI completa
9926730	Emulatore sonda Lambda
9926870	Gruppo termico Ø 63



◀ cod. **9926900**

Kit gruppo termico Ø 63 con centralina per Yamaha YZF R 125 cc 4t
Cilindro in alluminio | Cilindrata 182,67 cc - Corsa mm. 58,6 - Rapp. Comp. 1:11,5

RICAMBI

992539A	Pistone completo Ø 63
992539B	Pistone completo Ø 63
992539C	Pistone completo Ø 63
9925400	Serie segmenti Ø 63

9925590	Serie guarnizioni
9926870	Gruppo termico Ø 63
9926720	Cablaggio per centralina TFI
9926890	Centralina TFI completa



◀ cod. **9927120**

Gruppo termico Ø 63 per Fantic Caballero 125 cc 4t
Cilindro in alluminio | Cilindrata 182,67 cc - Corsa mm. 58,6 - Rapp. Comp. 1:11,5

RICAMBI

992539A	Pistone completo Ø 63
992539B	Pistone completo Ø 63
992539C	Pistone completo Ø 63

9925400	Serie segmenti Ø 63
9925590	Serie guarnizioni
9927670	Serie getti



◀ cod. **9927260**

Kit gruppo termico Ø 63 con centralina per Yamaha WR R 125 cc 4t
Cilindro in alluminio | Cilindrata 182,67 cc - Corsa mm. 58,6 - Rapp. Comp. 1:11,5

RICAMBI

992539A	Pistone completo Ø 63
992539B	Pistone completo Ø 63
992539C	Pistone completo Ø 63
9925400	Serie segmenti Ø 63

9925590	Serie guarnizioni
9926870	Gruppo termico Ø 63
9926720	Cablaggio per centralina TFI
9927250	Centralina TFI completa

ATTENZIONE: QUESTI PRODOTTI SONO DESTINATI ESCLUSIVAMENTE AD USO AGONISTICO. NE È QUINDI VIETATO L'UTILIZZO SU STRADA PUBBLICA.

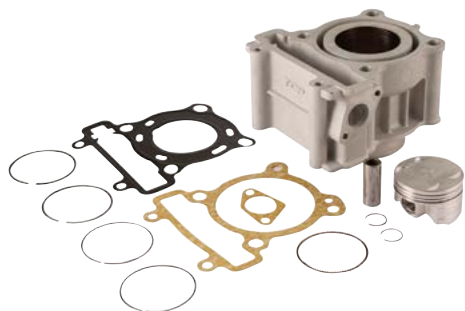

◀ cod. **9932700**
 Gruppo termico Ø 52 per motori Minarelli/Yamaha X-Max 125 cc 4T 4v
 Cilindro in alluminio | Cilindrata 124,6 cc - Corsa 58,6 - Rapp. Comp. 11,2:1

RICAMBI

9932750	Pistone completo Ø 52
9932760	Serie segmenti Ø 52

9932770	Serie guarnizioni
---------	-------------------



◀ cod. **9929650**
 Gruppo termico Ø 52,4 per Honda SH 125cc
 Cilindro in alluminio | Cilindrata 124,6 cc - Corsa mm 57,8 - Rapp. Comp. 1:11,5

RICAMBI

9929680	Pistone completo Ø 52,4
9929720	Serie segmenti Ø 52,4

9929750	Serie guarnizioni
---------	-------------------



◀ cod. **9929450**
 Gruppo termico Ø 58 per Honda SH 125cc
 Cilindro in alluminio | Cilindrata 152,7 cc - Corsa mm 57,8 - Rapp. Comp. 1:13,5

RICAMBI

9929520	Pistone completo Ø 58
9929560	Serie segmenti Ø 58

9929630	Serie guarnizioni
---------	-------------------



◀ cod. **9929950**
 Gruppo termico Ø 58 per Honda SH 150 cc
 Cilindro in alluminio | Cilindrata 152,7 cc - Corsa mm 57,8 - Rapp. Comp. 1:13,5

RICAMBI

9929520	Pistone completo Ø 58
9929560	Serie segmenti Ø 58

9929630	Serie guarnizioni
---------	-------------------

ATTENZIONE: QUESTI PRODOTTI SONO DESTINATI ESCLUSIVAMENTE AD USO AGONISTICO. NE È QUINDI VIETATO L'UTILIZZO SU STRADA PUBBLICA.



◀ **cod. 9929380**

Gruppo termico Ø 62,2 per Yamaha Majesty 125/150 cc

Cilindro in ghisa | Cilindrata 166 cc - Corsa mm 58,4 - Rapp. Comp. 1:11,7

RICAMBI

9929390	Pistone completo Ø 62,2
9929391	Pistone completo Ø 62,7
9929410	Serie segmenti Ø 62,2

9929411	Serie segmenti Ø 62,7
9929400	Serie guarnizioni



◀ **cod. 9926850**

Gruppo termico Ø 69 per Yamaha Majesty 250 cc

Cilindro in ghisa | Cilindrata 249,66 cc - Corsa mm. 66,8 - Rapp. Comp. 1:10,1

RICAMBI

9930470	Pistone completo Ø 69
9930380	Serie segmenti Ø 69

9930430	Serie guarnizioni
---------	-------------------



◀ **cod. 9936000**

Gruppo Termico Ø 60 Sym Symphony 125 Air Cooled

Il cilindro è realizzato in alluminio ad alto tenore di silicio

PEUGEOT TWEET 125 125 4T -00

SYM

FIDDLE II 125 4T 10-13, JET 4 125 4T 09-10, SYMPHONY 125 4T 09-09, SYMPHONY S 125 4T 09-10, SYMPHONY S 125 4T 12-12, SYMPHONY SR 125 4T 10-10, SYMPHONY SR 125 4T 12-14, SYMPHY II 125 4T 14-14

RICAMBI

9936110	Pistone completo Ø 60 Sym symphony 125
9936120	Serie segmenti Ø 60 Sym symphony125
9936130	Serie guarnizioni Ø .60 Sym symphony 125

NOVITÀ

ATTENZIONE: QUESTI PRODOTTI SONO DESTINATI ESCLUSIVAMENTE AD USO AGONISTICO. NE È QUINDI VIETATO L'UTILIZZO SU STRADA PUBBLICA.



◀ **cod. 9936200**
Gruppo Termico Ø 57 Sym Hd Joyride 125 LC
 Il cilindro è realizzato in alluminio ad alto tenore di silicio

SYM HD EU2 125 4T-4V 03-04, HD EU3 125 4T-4V 07-08, HD EVO 125 4T-4V 05-06, HD EVO EU3 125 4T-4V 07-08, HD EVO EU3 125 4T-4V 10-11, HD EVO TAMBURO EU3 125 4T-4V 08-09, HD2 125 4T-4V 11-11, HD2 125 4T-4V 14-14, JOYRIDE 125 4T-4V 01-02, JOYRIDE EU2 125 4T-4V 03-06, JOYRIDE EU3 125 4T-4V 07-07, JOYRIDE EVO 125 4T-4V 09-10, JOYRIDE EVO 125 4T-4V 13-14

SYM FIDDLE II 125 4T 10-13, JET 4 125 4T 09-10, SYMPHONY 125 4T 09-09, SYMPHONY S 125 4T 09-10, SYMPHONY S 125 4T 12-12, SYMPHONY SR 125 4T 10-10, SYMPHONY SR 125 4T 12-14, SYMPLY II 125 4T 14-14

NOVITÀ



◀ **cod. 9936400**
Gruppo Termico Ø 57,4 Kymco Agility 125/150
 Il cilindro è realizzato in alluminio ad alto tenore di silicio

KYMCO AGILITY 125 4T 06-06, AGILITY CARRY 125 4T 11-11, AGILITY CARRY EURO4 125 4T 17-17, AGILITY EU3 125 4T 06-08, AGILITY PLUS 125 4T 14-14, AGILITY PLUS E4 125 4T 16-16, AGILITY R16 125 4T 08-09, AGILITY R16 125 4T 12-12, AGILITY RS 125 4T 09-09, LIKE 125 4T 09-09, LIKE LX 125 4T 12-12, MOVIE 125 4T 99-00, MOVIE EU3 125 4T 06-07, MOVIE XL 125 4T 01-01, MOVIE XL EU2 125 4T 03-04, PEOPLE 125 4T 99-00, PEOPLE EU2 125 4T 03-03, PEOPLE EU3 125 4T 07-08, PEOPLE EU3 125 4T 11-11,

NOVITÀ

PEOPLE ONE E4 125 4T 16-16, PEOPLE ONE I 125 4T 13-13, PEOPLE ONE I DD 125 4T 15-15, PEOPLE S 125 4T 05-05, PEOPLE S DD EU3 125 4T 07-08, SUPER 8 125 4T 08-09, VIVIO 125 4T 00-00, MOVIE XL 150 4T 01-01, MOVIE XL EU2 150 4T 03-04, PEOPLE 150 4T 99-00, PEOPLE EU2 150 4T 03-03, VIVIO 150 4T 00-00

RICAMBI

9936490	Pistone completo Ø 57,4 125/150
9936500	Serie segmenti Ø 57,4 125/150
9936510	Serie guarnizioni Ø 57,4 125/150



◀ **cod. 9936650**
Gruppo termico Ø 52,4 Honda Pcx / Sh 125 Abs dal '13

APPLICABILITÀ

HONDA FORZA 125 4T-2V 13-17, PCX 125 4T-2V 13-17, SH I ABS 125 4T-2V 13-17

RICAMBI

9936520	Pistone completo Ø 52,4
9936560	Serie segmenti Ø 52,4
9936630	Serie guarnizioni

ATTENZIONE: QUESTI PRODOTTI SONO DESTINATI ESCLUSIVAMENTE AD USO AGONISTICO. NE È QUINDI VIETATO L'UTILIZZO SU STRADA PUBBLICA.



◀ cod. **9936950**
Gruppo termico Ø 58 Honda Pcx / Sh 150 Abs dal '13

APPLICABILITÀ

HONDA PCX 150 4T-2V 13-17, SH I ABS 150 4T-2V 13-17

RICAMBI

9937020	Pistone completo Ø 58
9937060	Serie segmenti Ø 58
9937130	Serie guarnizioni



◀ cod. **9937450**
Gruppo termico Ø 58 HONDA PCX / SH 125 ABS dal 2013

APPLICABILITÀ

HONDA FORZA 125 4T-2V 13-17, PCX 125 4T-2V 13-17, SH I ABS 125 4T-2V 13-17

RICAMBI

9937480	Pistone completo Ø 58
9937060	Serie segmenti Ø 58
9937130	Serie guarnizioni



◀ cod. **9911210** **RACING**

Kit Racing di trasformazione raffreddamento da aria ad acqua per motori Minarelli/Yamaha 50 cc orizzontale
Parte termica racing e pompa per il raffreddamento forzato, con tutti i dispositivi per la sua applicazione

RICAMBI

9910550	Pistone completo Ø 47
9908801	Pistone completo Ø 47,4
9908770	Segmento Ø 47
9908771	Segmento Ø 47,4
9910060	Serie guarnizioni

9910120	Testa
9910050	Accessori per testa
9905910	Spinotto
9912800	Gruppo termico Ø 47 "Due plus"
9911080	Coperchio volano completo



◀ cod. **9912800** **RACING**

Gruppo termico Ø 47 Racing "Due Plus" per motori Minarelli/Yamaha 50 cc Liquid Cooled
Cilindro in ghisa Minacrom con 8 travasi | Cilindrata 67,9 cc - Corsa mm. 39,2 - Rapp. Comp. 1:14 | Completo di testa

RICAMBI

9910550	Pistone completo Ø 47
9908801	Pistone completo Ø 47,4
9908770	Segmento Ø 47
9908771	Segmento Ø 47,4

9910060	Serie guarnizioni
9910120	Testa
9910050	Accessori per testa
9905910	Spinotto



◀ cod. **9921160** **RACING**

Gruppo termico Ø 47 Racing "Due Plus" con testa scomposta per motori Minarelli/Yamaha 50 cc Liquid Cooled
Cilindro in ghisa Minacrom con 8 travasi | Cilindrata 68,3 cc - Corsa mm. 39,2 - Rapp. Comp. 1:14 | Completo di testa

RICAMBI

9910550	Pistone completo Ø 47
9908801	Pistone completo Ø 47,4
9908770	Segmento Ø 47
9908771	Segmento Ø 47,4
9921310	Serie guarnizioni

9920500	Testa scomponibile
9910050	Accessori per testa
9905910	Spinotto
9914540	Gabbia a rulli

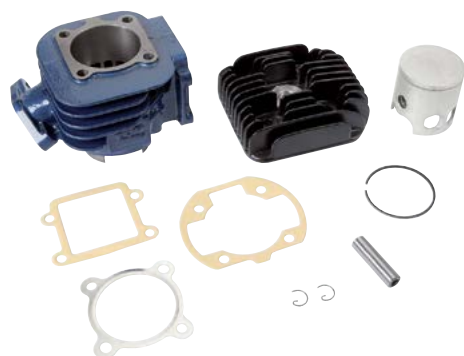

◀ cod. **9930000** **RACING**

Gruppo termico Ø 47 Racing "Gold line" per motori Minarelli/Yamaha tipo verticale
Cilindro in ghisa Minacrom 7 travasi | Cilindrata 67,9 cc - Corsa mm. 39,2 - Rapp. Comp. 1:13,7 | Completo di testa

RICAMBI

9908800	Pistone completo Ø 47
9908801	Pistone completo Ø 47,4
9908770	Segmento Ø 47
9908771	Segmento Ø 47,4

9906760	Serie guarnizioni
9930020	Testa Black
9905910	Spinotto

ATTENZIONE: QUESTI PRODOTTI SONO DESTINATI ESCLUSIVAMENTE AD USO AGONISTICO. NE È QUINDI VIETATO L'UTILIZZO SU STRADA PUBBLICA.

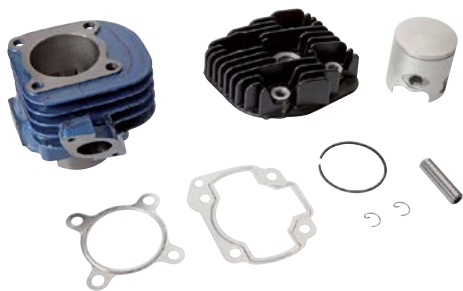

◀ cod. **9930030** **RACING**

Gruppo termico "Gold Line" Ø 47 Racing per motori Minarelli/Yamaha
tipo orizzontale air cooled

Cilindro in ghisa Minacrom 8 travasi | Cilindrata 67,9 cc - Corsa mm. 39,2 - Rapp. Comp. 1:13,6 | Completo di testa

RICAMBI

9908800	Pistone completo Ø 47
9908801	Pistone completo Ø 47,4
9908770	Segmento Ø 47
9908771	Segmento Ø 47,4

9907060	Serie guarnizioni
9930050	Testa Black
9905910	Spinotto

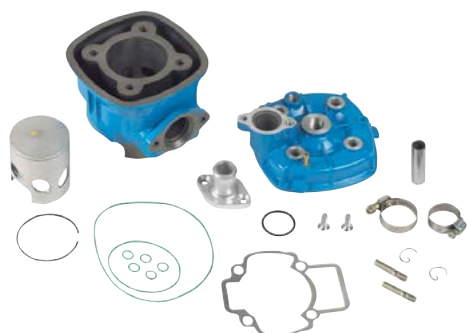

◀ cod. **9920590** **RACING**

Gruppo termico Ø 47,6 racing "Due Plus" per motori Gilera/Piaggio 50 cc liquid cooled

Cilindro in ghisa Minacrom con 6 travasi | Cilindrata 69,9 cc - Corsa mm. 39,3 - Rapp. Comp. 1:14 | Completo di testa

RICAMBI

9920650	Pistone completo Ø 47,6
9920651	Pistone completo Ø 48
9913700	Segmento Ø 47,6
9913701	Segmento Ø 48

9920660	Serie guarnizioni
9920620	Testa
9915950	Raccordo per testa



◀ cod. **9921550** **RACING**

Gruppo termico Ø 47,6 "TPR" in alluminio per motori Gilera/Piaggio 50 cc air cooled

Cilindro in alluminio | Cilindrata 69,9 cc - Corsa mm. 39,3 - Rapp. Comp. 1:14,7 | Completo di testa

RICAMBI

992153A	Pistone completo Ø 47,6
992153B	Pistone completo Ø 47,6
992153C	Pistone completo Ø 47,6
9921540	Segmento Ø 47,6

9921650	Serie guarnizioni
9913680	Testa
9907820	Gabbia a rulli
9921520	Spinotto Ø 12



◀ cod. **9921630** **RACING**

Gruppo termico Ø 47,6 "TPR" in alluminio per motori scooter 50 cc Minarelli/Yamaha
tipo orizzontale air cooled

Cilindro in alluminio | Cilindrata 69,9 cc - Corsa mm. 39,2 - Rapp. Comp. 1:14,5 | Completo di testa

RICAMBI

992161A	Pistone completo Ø 47,6
992161B	Pistone completo Ø 47,6
992161C	Pistone completo Ø 47,6
9921540	Segmento Ø 47,6

9907060	Serie guarnizioni
9910540	Testa
9914540	Gabbia a rulli
9921600	Spinotto Ø 10

ATTENZIONE: QUESTI PRODOTTI SONO DESTINATI ESCLUSIVAMENTE AD USO AGONISTICO. NE È QUINDI VIETATO L'UTILIZZO SU STRADA PUBBLICA.



cod. 9921640 **RACING**

Gruppo termico Ø 47,6 "TPR" in alluminio per motori scooter 50 cc Minarelli/Yamaha tipo verticale air cooled
Cilindro in alluminio | Cilindrata 69,9 cc - Corsa mm. 39,2 - Rapp. Comp. 1:14,5 | Completo di testa

RICAMBI

992161A	Pistone completo Ø 47,6
992161B	Pistone completo Ø 47,6
992161C	Pistone completo Ø 47,6
9921540	Segmento Ø 47,6

9906760	Serie guarnizioni
9908790	Testa
9914540	Gabbia a rulli
9921600	Spinotto Ø 10

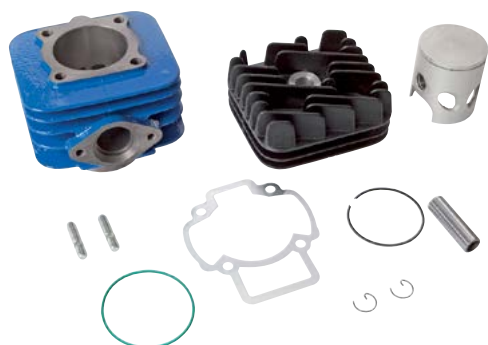

cod. 9930060 **RACING**

Gruppo termico Ø 47,6 Racing "Gold line" per motori Gilera/Piaggio 50 cc air cooled
Cilindro in ghisa Minacrom 6 travasi di cui 4 contrapposti (2 posizionati posteriormente per ottimizzare il riempimento)
| Cilindrata 69,9 cc - Corsa mm. 39,3 - Rapp. Comp. 1:13,5 | Completo di testa

RICAMBI

9920650	Pistone completo Ø 47,6
9920651	Pistone completo Ø 48
9913700	Segmento Ø 47,6

9913701	Segmento Ø 48
9914290	Serie guarnizioni
9930080	Testa Black



cod. 9919240 **RACING**

Gruppo termico Ø 49,5 Racing per motori Minarelli 50 cc AM6 EU1 AM345/6
Cilindro in ghisa Minacrom 5 travasi | Cilindrata 75 cc - Corsa mm. 39 - Rapp. Comp. 1:13 | Completo di testa

RICAMBI

9915780	Pistone completo Ø 49,5
9915781	Pistone completo Ø 49,7
9915710	Segmento Ø 49,5
9915711	Segmento Ø 49,7

9907070	Serie guarnizioni
9915870	Testa
9906600	Spinotto



cod. 9921150 **RACING**

Gruppo termico Ø 49,5 Racing "Due plus" con testa scomposta per motori Minarelli 50 cc AM
Cilindro in ghisa Minacrom 5 travasi | Cilindrata 75 cc - Corsa mm 39 - Rapp. Comp. 1:14,5 | Completo di testa

RICAMBI

9915780	Pistone completo Ø 49,5
9915781	Pistone completo Ø 49,7
9915710	Segmento Ø 49,5
9915711	Segmento Ø 49,7

9921320	Serie guarnizioni
9920530	Testa scomponibile
9921330	Gabbia a rulli
9906600	Spinotto



◀ **cod. 9921450** **RACING**

Gruppo termico Ø 49,5 **Maxi Kit Racing** per motori Minarelli AM 50 cc
Cilindro in ghisa Minacrom | Cilindrata 85 cc - Corsa mm. 44 - Rapp. Comp. 1:14,7 | Completo di testa

RICAMBI

9921760	Gruppo termico Ø 49,5
9915780	Pistone completo Ø 49,5
9915781	Pistone completo Ø 49,7
9915710	Segmento Ø 49,5
9915711	Segmento Ø 49,7
9921320	Serie guarnizioni

9921460	Testa scomponibile
9906600	Spinotto
9920410	Albero motore
9921330	Gabbia a rulli
9921770	Chiavetta
9924750	Kit cuscinetti paraoli banco

NB: il codice 9921760 deve essere tassativamente montato con il codice 9920410.



◀ **cod. 9924130** **RACING**

Gruppo termico Ø 50 "TPR" in alluminio per motori Minarelli AM 50 cc
Cilindro in alluminio | Cilindrata 76,5 cc - Corsa mm 39 - Rapp. Comp. 1:14 | Completo di testa

RICAMBI

992414A	Pistone completo Ø 50
992414B	Pistone completo Ø 50
992414C	Pistone completo Ø 50
9924150	Segmento Ø 50
9924160	Serie guarnizioni

9920530	Testa scomponibile
9921330	Gabbia a rulli
9924250	Spinotto e anellini
9924110	Boccola riduzione scarico Ø 28/32mm
9924120	Boccola scarico Ø 32 mm



◀ **cod. 9924240** **RACING**

Gruppo termico Ø 50 **Maxi Kit "TPR"** per motori Minarelli AM 50 cc
Cilindro in alluminio | Cilindrata 86 cc - Corsa mm 44 - Rapp. Comp. 1:14,2 | Completo di testa

RICAMBI

9924230	Gruppo termico Ø 50
992414A	Pistone completo Ø 50
992414B	Pistone completo Ø 50
992414C	Pistone completo Ø 50
9924150	Segmento Ø 50
9924160	Serie guarnizioni
9921460	Testa scomponibile

9924110	Boccola Ø 28/32 mm
9924120	Boccola Ø 32 mm scarico
9924250	Spinotto e anellini
9920410	Albero motore
9921770	Chiavetta scarico
9921330	Gabbia a rulli
9924750	Kit cuscinetti paraoli banco

NB: il codice 9924230 deve essere tassativamente montato con il codice 9920410.



◀ **cod. 9926560** **RACING**

Gruppo termico Ø 50 **Maxi Kit "TPR"** per motori scooter 50 cc Minarelli/Yamaha liquid cooled corsa 44
Cilindro in alluminio | Cilindrata 86 cc - Corsa mm. 44 - Rapp. Comp. 1:15 | Completo di testa

RICAMBI

9929310	Gruppo termico Ø 50
992414A	Pistone completo Ø 50
992414B	Pistone completo Ø 50
992414C	Pistone completo Ø 50
9924150	Segmento Ø 50
9929330	Serie guarnizioni
9929320	Testa

9924250	Spinotto e anellini
9929480	Serie prigionieri
KK01002	Kit cuscinetti paraoli banco
9925980	Albero motore
9925930	Biella
9921330	Gabbia a rulli

ATTENZIONE: QUESTI PRODOTTI SONO DESTINATI ESCLUSIVAMENTE AD USO AGONISTICO. NE È QUINDI VIETATO L'UTILIZZO SU STRADA PUBBLICA.



cod. **9926580** **RACING**

Gruppo termico Ø 50 **Maxi Kit "TPR"** per motori scooter 50 cc Minarelli/Yamaha liquid cooled corsa 39,2
Cilindro in alluminio | Cilindrata 77 cc - Corsa mm. 39,2 - Rapp. Comp. 1:14,5 | Completo di testa

RICAMBI

9929340	Gruppo termico Ø 50
992414A	Pistone completo Ø 50
992414B	Pistone completo Ø 50
992414C	Pistone completo Ø 50
9924150	Segmento Ø 50
9929330	Serie guarnizioni

9929350	Testa
9924250	Spinotto e anellini
KK01002	Kit cuscinetti e paraoli banco
9926170	Albero motore
9925930	Biella
9921330	Gabbia a rulli



cod. **9928390** **RACING**

Gruppo termico Ø 50 **Maxi Kit "TPR"** per motori scooter 50 cc Piaggio/Gilera/Derbi liquid cooled corsa 39,3
Cilindro in alluminio | Cilindrata 77 cc - Corsa mm. 39,3 - Rapp. Comp. 1:14,5 | Completo di testa

RICAMBI

9929800	Gruppo termico Ø 50
992414A	Pistone completo Ø 50
992414B	Pistone completo Ø 50
992414C	Pistone completo Ø 50
9924150	Segmento Ø 50
9929820	Serie guarnizioni

9929810	Testa
9924250	Spinotto e anellini
KK01009	Kit cuscinetti e paraoli banco
9926220	Albero motore
9929470	Biella
9921330	Gabbia a rulli



cod. **9928440** **RACING**

Gruppo termico Ø 50 **Maxi Kit "TPR"** per motori scooter 50 cc Piaggio/Gilera/Derbi liquid cooled corsa 44
Cilindro in alluminio | Cilindrata 86 cc - Corsa mm. 44 - Rapp. Comp. 1:15 | Completo di testa

RICAMBI

9929840	Gruppo termico Ø 50
992414A	Pistone completo Ø 50
992414B	Pistone completo Ø 50
992414C	Pistone completo Ø 50
9924150	Segmento Ø 50
9929820	Serie guarnizioni

9929850	Testa
9924250	Spinotto e anellini
KK01009	Kit cuscinetti e paraoli banco
9926210	Albero motore
9929470	Biella
9921330	Gabbia a rulli



cod. **9928480** **RACING**

Gruppo Termico Ø 47,6 Spinotto 10 "**TPR 2**" motori scooter 50 cc Minarelli/Yamaha Liquid Cooled

RICAMBI

9914540	Gabbia a rulli
9920500	Testa Scomponibile
9921540	Segmento Ø 47,6
992847A	Pistone Completo Ø 47,6

992847B	Pistone Completo Ø 47,6
992847C	Pistone Completo Ø 47,6
9931280	Serie Guarnizioni

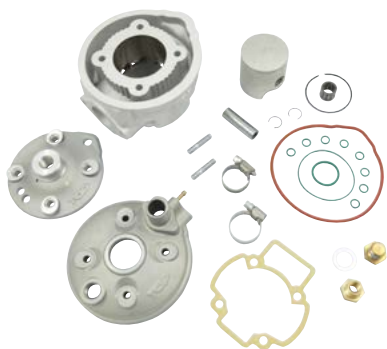

◀ **cod. 9928520** **RACING**
Gruppo Termico Ø 47,6 "TPR 2" motori scooter 50 cc Piaggio Liquid Cooled

RICAMBI

9907820	Gabbia a rulli
9921360	Testa Scomponibile
9921540	Segmento Ø 47,6
992851A	Pistone Completo Ø 47,6

992851B	Pistone Completo Ø 47,6
992851C	Pistone Completo Ø 47,6
9931390	Serie Guarnizioni



◀ **cod. 9928550** **RACING**
Gruppo Termico Ø 47,6 Spinotto 12 "TPR 2" motori scooter 50 cc Minarelli/Yamaha Liquid Cooled

RICAMBI

9920500	Testa Scomponibile
9921330	Gabbia A Rulli
9921540	Segmento Ø 47,6
992851A	Pistone Completo Ø 47,6

992851B	Pistone Completo Ø 47,6
992851C	Pistone Completo Ø 47,6
9931280	Serie Guarnizioni



◀ **cod. 9934270** **RACING**
Maxi Kit Racing 86 cc Derbi Senda Ø 50 (D50b0)

APPLICABILITÀ

APRILIA RS 50 2T 06-10, RS4 50 2T 11-13, RS4 REPLICIA 50 2T 14-16, RX 50 2T 06-10, RX 50 2T 14-16, SX 50 2T 06-16, SX LIMITED EDITION 50 2T 14-16

DERBI GPR 2T 50 2T 13-13, GPR 2T EU2 50 2T 09-10, GPR NUDE & GPR NUDE TUNING 50 2T 06-08, GPR NUDE SPORT 50 2T 06-06, GPR R EU2 - GPR REPLICIA EU2 50 2T 08-08, GPR RACING EU2 50 2T 06-06, GPR REPLICIA & GPR R EU2 50 2T 06-06, GPR REPLICIA 2T MALOSSÌ 50 2T 07-07, GPR REPLICIA PESEK EU2 50 2T 07-07, SENDA HYP DRD EVO EU2 50 2T 08-09, SENDA HYP DRD EVO LIMITED EDITION EU2 50 2T 08-08, SENDA R DRD PRO EU2 50 2T 05-11, SENDA R DRD RACING EU2 50 2T 05-08, SENDA R DRD X-TREME 2T EU2 50 2T 14-15, SENDA R DRD X-TREME 2T EURO2 50 2T 10-12, SENDA R X-RACE 2T EU2 50 2T 10-10, SENDA R X-RACE EU2 50 2T 06-09, SENDA R X-TREME 2T EU2 50 2T 10-10, SENDA R X-TREME EU2 50 2T 05-08, SENDA SM DRD PRO EU2 50 2T 05-11, SENDA SM DRD PRO EU2 2VER 50 2T 05-08, SENDA SM DRD RACING EU2 50 2T 05-08, SENDA SM DRD RACING EU2 50 2T 10-13, SENDA SM DRD RACING LTD EU2 50 2T 07-07, SENDA SM DRD X-TREME 2T EU2 50 2T 14-15, SENDA SM DRD X-TREME 2T EU2 LIMITED ED 50 2T 14-15, SENDA SM X-RACE 2T EU2 50 2T 10-10, SENDA SM X-RACE EU2 50 2T 06-09, SENDA SM X-RACE EU2 2VER 50 2T 07-09, SENDA SM X-TREME 2T EU2 50 2T 10-10, SENDA SM X-TREME EU2 50 2T 05-08

GILERA RCR 50 2T 06-07, RCR 50 2T 11-12, RCR (CHE-SYC) 50 2T 13-15, SMT 50 2T 06-17, SMT RACING 50 2T 11-12

VALENTI RACING RME 50 2T 15-17, SM 50 2T 15-17

RICAMBI

9924150	SEGMENTO D.50 PER GR.TERM.D.50 "TPR"
9924151	SEGMENTO D.50,4 PER GR.TERM.D.50 "TPR"
9924250	SPINOTTO+ANELLINI PER PIST.D.50 "TPR" AM6
9927010	PISTONE COMPL. D.50 PER DERBI SENDA
9927011	PISTONE COMPL. D.50,4 PER DERBI SENDA
9928090	RACCORDO TESTA GT D.39,885 DERBI SENDA (D50B0)
9930210	ALBERO MOTORE CORSA 44MM PER DERBI (D50B0)

9930240	SERIE GUARNIZIONI GT DERBI SENDA (D50B0)
9930270	TAPPO CILINDRICO M16x1,5 C/RONDELLA IN RAME X GT DERBI (D50B0)
9934260	GRUPPO TERM. D.50 PER MAXI KIT 86 cc DERBI (D50B0)
9934280	TESTA D.50 PIAGGIO/DERBI (D50B0) PER CORSA 44MM
AA00766	GABBIA SU SPINOTTO D.12X15X15 AM6-DERBI
KK01008	KIT CUSCIN/PARAOLI BANCO DERBI PLURIMARC

ATTENZIONE: QUESTI PRODOTTI SONO DESTINATI ESCLUSIVAMENTE AD USO AGONISTICO. NE È QUINDI VIETATO L'UTILIZZO SU STRADA PUBBLICA.

CARBURATORE MIKUNI TM 24



◀ cod. **9908730** **RACING**
Carburatore Mikuni TM 24

RICAMBI

9909090	Serie getti per carburatore Mikuni TM 24
9909830	Kit spilli conici per Mikuni TM 24

A RICAMBIO PER

9930830	Kit aspirazione completo "TPR" per scooter 50 cc Minarelli/Yamaha orizzontale collettore 360° - carburatore Mikuni TM 24
9930870	Kit aspirazione completo "TPR" per scooter 50 cc Piaggio - collettore 360° - carburatore Mikuni TM 24

9930910	Kit aspirazione completo "TPR" per AM/ Derbi 50 cc - collettore 360° - carburatore Mikuni TM 24
---------	---

FILTRI ARIA **RACING**



◀ cod. **9908680**
Filtro aria per carburatori con diametro attacco filtro 42 mm

◀ cod. **9910200**
Filtro aria per carburatori con diametro attacco filtro 39 mm

◀ cod. **9910300**
Filtro aria per carburatori con diametro attacco filtro 42 mm, completo di manicotto a 90°

◀ cod. **9911680**
Filtro aria per carburatori con diametro attacco filtro 35 mm

ATTENZIONE: QUESTI PRODOTTI SONO DESTINATI ESCLUSIVAMENTE AD USO AGONISTICO. NE È QUINDI VIETATO L'UTILIZZO SU STRADA PUBBLICA.

KIT ASPIRAZIONE - KIT COLLETTORI - CARBURATORE MIKUNI TM 24



◀ cod. **9930820** **RACING**
Kit collettore "TPR" 360° scooter 50 cc Minarelli/Yamaha orizzontale per carburatore Mikuni TM 24

RICAMBI

9929270	Flangia	9929280	Collettore
---------	---------	---------	------------

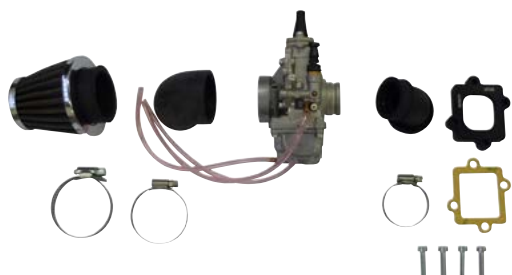

◀ cod. **9930830** **RACING**
Kit aspirazione completo "TPR" per scooter 50 cc Minarelli/Yamaha orizzontale collettore 360° - carburatore Mikuni TM 24

RICAMBI

9908680	Filtro aria	9929270	Flangia
9908730	Carburatore Mikuni TM 24	9929280	Collettore



◀ cod. **9930860** **RACING**
Kit collettore "TPR" 360° scooter 50 cc Piaggio per carburatore Mikuni TM 24

RICAMBI

9929210	Flangia	9929220	Collettore
---------	---------	---------	------------

ATTENZIONE: QUESTI PRODOTTI SONO DESTINATI ESCLUSIVAMENTE AD USO AGONISTICO. NE È QUINDI VIETATO L'UTILIZZO SU STRADA PUBBLICA.

KIT ASPIRAZIONE - KIT COLLETTORI - CARBURATORE MIKUNI TM 24

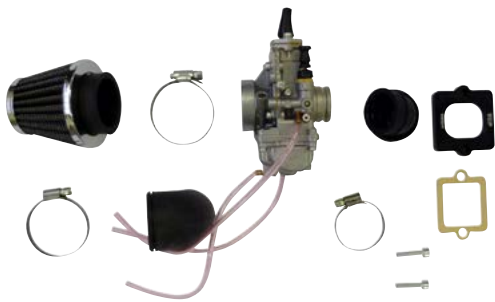

cod. **9930870** **RACING**
 Kit aspirazione completo "TPR" per scooter 50 cc Piaggio
 collettore 360° - carburatore Mikuni TM 24

RICAMBI

9908680	Filtro aria
9908730	Carburatore Mikuni TM 24

9929210	Flangia
9929220	Collettore



cod. **9930900** **RACING**
 Kit collettore "TPR" 360° per AM/Derbi 50 cc per carburatore Mikuni TM 24

RICAMBI

9929240	Flangia
---------	---------

9929250	Collettore
---------	------------

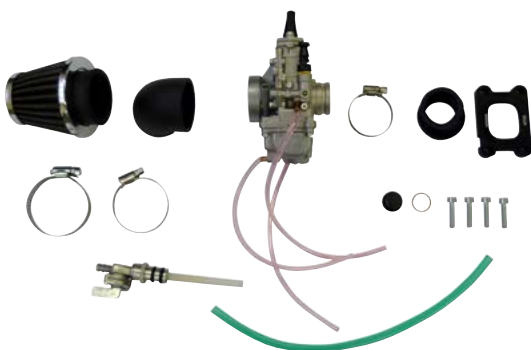

cod. **9930910** **RACING**
 Kit aspirazione completo "TPR" per AM/Derbi 50 cc
 collettore 360° - carburatore Mikuni TM 24

RICAMBI

9908680	Filtro aria
9908730	Carburatore Mikuni TM 24

9929240	Flangia
9929250	Collettore

ATTENZIONE: QUESTI PRODOTTI SONO DESTINATI ESCLUSIVAMENTE AD USO AGONISTICO. NE È QUINDI VIETATO L'UTILIZZO SU STRADA PUBBLICA.

CARBURATORE OKO 28



◀ cod. **9932000** **RACING**
Carburatore OKO 28

A RICAMBIO PER

9931710	Kit aspirazione completo "TPR" per scooter 50 cc Minarelli/Yamaha orizzontale collettore 360° - carburatore OKO 28
9931730	Kit aspirazione completo "TPR" per scooter 50 cc Piaggio collettore 360° - carburatore OKO 28
9931750	Kit aspirazione completo "TPR" per AM/Derbi 50 cc collettore 360° - carburatore OKO 28
9932800	Kit aspirazione completo "TPR" per Vespa Px 125/150 cc - Collettore 360° Oko 28

GETTI

DESCRIZIONE	CODICE	DESCRIZIONE	CODICE
GETTO MINIMO OKO #30	9940300	GETTO MASSIMO OKO #132	9941320
GETTO MINIMO OKO #32	9940320	GETTO MASSIMO OKO #135	9941350
GETTO MINIMO OKO #34	9940340	GETTO MASSIMO OKO #138	9941380
GETTO MINIMO OKO #36	9940360	GETTO MASSIMO OKO #140	9941400
GETTO MINIMO OKO #38	9940380	GETTO MASSIMO OKO #142	9941420
GETTO MINIMO OKO #40	9940400	GETTO MASSIMO OKO #145	9941450
GETTO MINIMO OKO #42	9940420	GETTO MASSIMO OKO #148	9941480
GETTO MINIMO OKO #44	9940440	GETTO MASSIMO OKO #150	9941500
GETTO MINIMO OKO #46	9940460	GETTO MASSIMO OKO #152	9941520
GETTO MINIMO OKO #48	9940480	GETTO MASSIMO OKO #155	9941550
GETTO MINIMO OKO #50	9940500	GETTO MASSIMO OKO #158	9941580
GETTO MINIMO OKO #52	9940520	GETTO MASSIMO OKO #160	9941600
GETTO MINIMO OKO #54	9940540	GETTO MASSIMO OKO #162	9941620
GETTO MINIMO OKO #56	9940560	GETTO MASSIMO OKO #165	9941650
GETTO MINIMO OKO #58	9940580	GETTO MASSIMO OKO #168	9941680
GETTO MINIMO OKO #60	9940600	GETTO MASSIMO OKO #170	9941700
GETTO MASSIMO OKO #100	9941000	GETTO MASSIMO OKO #172	9941720
GETTO MASSIMO OKO #102	9941020	GETTO MASSIMO OKO #175	9941750
GETTO MASSIMO OKO #105	9941050	GETTO MASSIMO OKO #178	9941780
GETTO MASSIMO OKO #108	9941080	GETTO MASSIMO OKO #180	9941800
GETTO MASSIMO OKO #110	9941100	GETTO MASSIMO OKO #182	9941820
GETTO MASSIMO OKO #112	9941120	GETTO MASSIMO OKO #185	9941850
GETTO MASSIMO OKO #115	9941150	GETTO MASSIMO OKO #188	9941880
GETTO MASSIMO OKO #118	9941180	GETTO MASSIMO OKO #190	9941900
GETTO MASSIMO OKO #120	9941200	GETTO MASSIMO OKO #192	9941920
GETTO MASSIMO OKO #122	9941220	GETTO MASSIMO OKO #195	9941950
GETTO MASSIMO OKO #125	9941250	GETTO MASSIMO OKO #198	9941980
GETTO MASSIMO OKO #128	9941280	GETTO MASSIMO OKO #200	9942000
GETTO MASSIMO OKO #130	9941300		

ATTENZIONE: QUESTI PRODOTTI SONO DESTINATI ESCLUSIVAMENTE AD USO AGONISTICO. NE È QUINDI VIETATO L'UTILIZZO SU STRADA PUBBLICA.

KIT ASPIRAZIONE

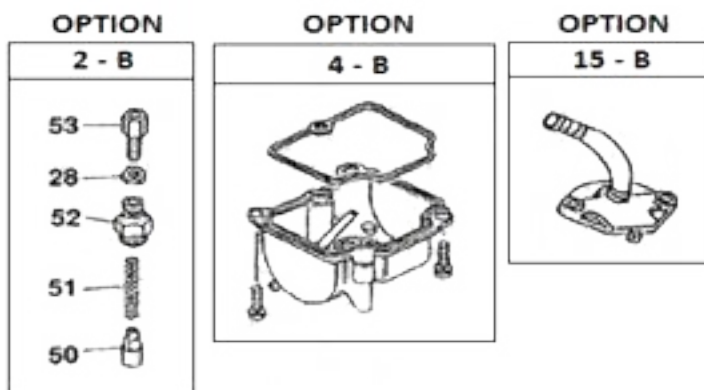
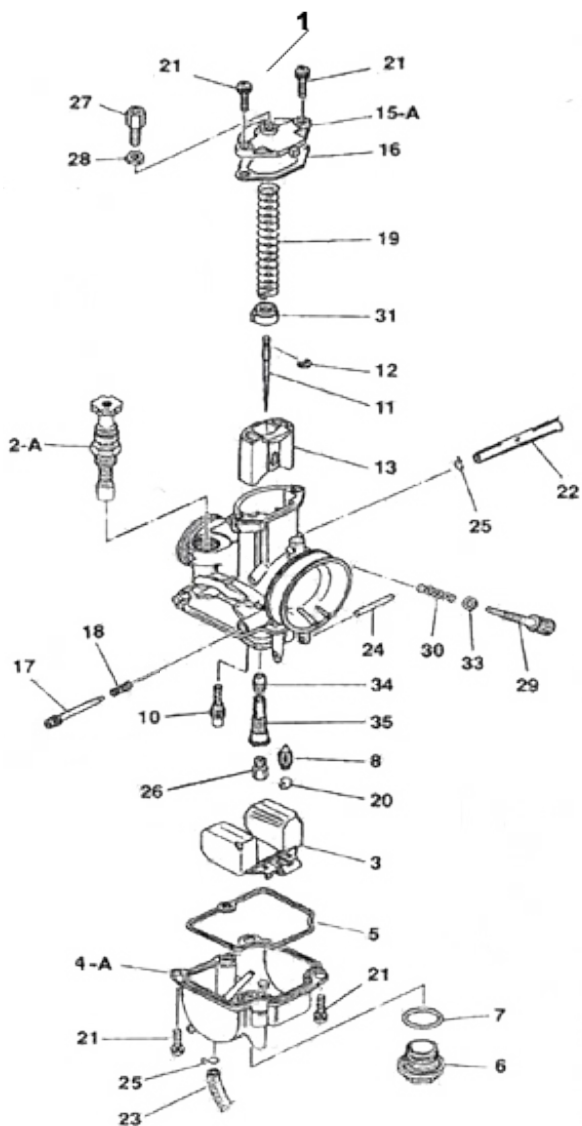

RICAMBI

N°	DESCRIZIONE	CODICE
1	Carburatore OKO 28	9932000
2A	Comando Starter	9932010
2B	Comando Starter a Filo	9932020
3	Galleggiante	9932030
4A	Vaschetta Carburatore	9932040
4B	Vaschetta Carburatore Trasparente	9932050
5	Guarnizione Vaschetta	9932060
6	Tappo Vaschetta	9932070
7	O-Ring Tappo Vaschetta	9932080
8	Spillo Benzina	9932090
10	Getto Minimo #48	9940480
11	Spillo Conico [JJH]	9932110
12	Seeger Spillo Conico	9932120
13	Valvola Gas	9932130
15A	Coperchio Valvola	9932140
15B	Coperchio Valvola con Registro Curvo	9932150
16	Guarnizione Coperchio Valvola	9932160
17	Vite Aria	9932170
18	Molla Vite Aria	9932180
19	Molla Valvola Gas	9932190
20	Seeger Spillo Benzina	9932200
21	Vite fissaggio Vaschetta/Coperchio	9932210
22	Tubetto Sfiato	9932220
23	Tubetto Troppo Pieno	9932230
24	Perno Galleggiante	9932240
25	Seeger Tubetti	9932250
26	Getto Massimo #130	9941300
27	Registro Cavo Gas	9932270
28	Dado Registro Cavo Gas	9932280
29	Vite Registro Valvola Gas	9932290
30	Molla Vite Registro Valvola Gas	9932300
31	Guida Molla Valvola Gas	9932310
33	Rondella Vite Registro Valvola Gas	9932320
34	Ugello Polverizzatore	9932330
35	Polverizzatore	9932340
50	Valvola Starter a Filo	9932350
51	Molla Valvola Starter a Filo	9932360
52	Coperchio Starter a Filo	9932370
53	Registro Starter a Filo	9932380

KIT ASPIRAZIONE - KIT COLLETTORI - CARBURATORE OKO 28



◀ cod. **9931710** **RACING**

Kit aspirazione completo "TPR" per scooter 50 cc Minarelli/Yamaha orizzontale collettore 360° - carburatore OKO 28

RICAMBI

9929270	Flangia
9929290	Collettore

9931770	Filtro aria
9932000	Carburatore OKO 28



◀ cod. **9931700** **RACING**

Kit collettore "TPR" 360° scooter 50 cc Minarelli/Yamaha orizzontale per carburatore OKO 28

RICAMBI

9929270	Flangia
---------	---------

9929290	Collettore
---------	------------



◀ cod. **9931730** **RACING**

Kit aspirazione completo "TPR" per scooter 50 cc Piaggio collettore 360° - carburatore OKO 28

RICAMBI

9929210	Flangia
9929230	Collettore

9931770	Filtro aria
9932000	Carburatore OKO 28



◀ cod. **9931720** **RACING**

Kit collettore "TPR" 360° scooter 50 cc Piaggio per carburatore OKO 28

RICAMBI

9929210	Flangia
---------	---------

9929230	Collettore
---------	------------

ATTENZIONE: QUESTI PRODOTTI SONO DESTINATI ESCLUSIVAMENTE AD USO AGONISTICO. NE È QUINDI VIETATO L'UTILIZZO SU STRADA PUBBLICA.



◀ cod. **9931750** **RACING**

Kit aspirazione completo "TPR" per AM/Derbi 50 cc
collettore 360° - carburatore OKO 28

RICAMBI

9929240	Flangia
9929260	Collettore

9931770	Filtro aria
9932000	Carburatore OKO 28



◀ cod. **9931740** **RACING**

Kit collettore "TPR" 360° AM/Derbi 50 cc per carburatore OKO 28

RICAMBI

9929240	Flangia
---------	---------

9929260	Collettore
---------	------------



◀ cod. **9931770** **RACING**

Filtro aria spugna imbocco Ø 49 mm

A RICAMBIO PER

9931710	Kit aspirazione completo "TPR" per scooter 50 cc Minarelli/Yamaha orizzontale collettore 360° - carburatore OKO 28
9931730	Kit aspirazione completo "TPR" per scooter 50 cc Piaggio collettore 360° - carburatore OKO 28
9931750	Kit aspirazione completo "TPR" per AM/Derbi 50 cc collettore 360° - carburatore OKO 28



◀ cod. **9932800** **RACING**

Kit aspirazione completo per vespa PX 125/150 cc "TPR" collettore 360° - carburatore OKO 28

RICAMBI

9931770	Filtro Aria
9932000	Carburatore Oki 28
9932890	Kit Collettore
9933240	Kit Flangia Inferiore

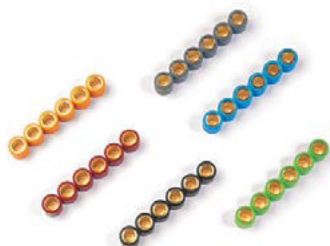

◀ Serie 6 masse variatore Ø 15x12

APPLICABILITÀ

APRILIA - ATALA - BENELLI - BETA - ITALJET - KTM - MACAL - MALAGUTI - MBK - MOTRON - RIEJU - YAMAHA
APPLICABILI A TUTTI I VARIATORI TOP PERFORMANCES

Codice	Peso
9912900	4
9912920	4,5
9912910	5

Codice	Peso
9906140	5,5
9912940	6
9915570	7,5

Codice	Peso
9927160	3,8
9912930	6,5
9925610	6,9



◀ Serie 6 masse variatore Ø 15x12 in alluminio

APPLICABILITÀ

APRILIA - ATALA - BENELLI - BETA - ITALJET - KTM - MACAL - MALAGUTI - MBK - MOTRON - RIEJU - YAMAHA
APPLICABILI A TUTTI I VARIATORI TOP PERFORMANCES

Codice	Peso
9912870	2,5
9912840	2,8

Codice	Peso
9912880	3
9912850	3,3

Codice	Peso
9912890	3,5
9912860	3,8



◀ Serie 6 masse variatore Ø 16x13 per variatori originali

APPLICABILITÀ

BSV - GILERA - HONDA - HSC - PEUGEOT - PIAGGIO

Codice	Peso
9920030	4,2
9920040	4,6
9920050	5
9914390	5,5
9914380	6

Codice	Peso
9914400	6,5
9914370	7
9914410	7,5
9914360	8
9915400	8,5

Codice	Peso
9920060	8,8
9920070	9,2
9920080	9,5
9920090	9,7
9920100	10,2



◀ Serie 6 masse variatore Ø 16x13 in alluminio

APPLICABILITÀ

BSV - GILERA - HONDA - HSC - PEUGEOT - PIAGGIO

Codice	Peso
9911960	3
9911990	3,3

Codice	Peso
9911980	3,8
9911970	4,2

Codice	Peso
9911950	4,6
9911940	5



◀ Serie 6 masse variatore Ø 17x12,5

APPLICABILITÀ

SUZUKI - MORINI - ITALJET - MALAGUTI - APRILIA SR

Codice	Peso
9919870	4
9919880	4,5
9919890	5
9919900	5,5

Codice	Peso
9915190	5,9
9919910	6
9919920	6,5
9915200	6,8

Codice	Peso
9919930	7
9920540	7,5
9915210	11,3



◀ Serie 6 masse variatore Ø 18x13,8

APPLICABILITÀ
KYMCO PEOPLE

Codice	Peso
9917640	13

Codice	Peso
9917660	12

◀ Serie 6 masse variatore Ø 19x13,8

APPLICABILITÀ
PIAGGIO LIBERTY 125 CC

Codice	Peso
9922810	10

Codice	Peso
9922830	11

Codice	Peso
9922850	12

◀ Serie 6 masse variatore Ø 19x15,5

APPLICABILITÀ
DERBI - GILERA - PIAGGIO

Codice	Peso
9919940	4,8
9919950	5,2
9919960	5,6

Codice	Peso
9919970	6
9919980	6,5
9919990	7

Codice	Peso
9922890	7,5
9920000	8
9920010	9

◀ Serie 6 masse variatore Ø 19x17

APPLICABILITÀ
GILERA - PIAGGIO

Codice	Peso
9922710	5,4
9922730	6,1
9922750	6,6
9922770	7,3

Codice	Peso
9922790	7,7
9916340	8,5
9916360	9
9916380	9,5

Codice	Peso
9916400	10
9916420	11
9915290	13

◀ Serie 6 masse variatore Ø 20x12

APPLICABILITÀ
MINARELLI / YAMAHA 125-150 CC

Codice	Peso
9916120	8
9916140	8,5

Codice	Peso
9915270	9
9916160	9,5

Codice	Peso
9916200	10,5
9916220	11



◀ Serie 8 masse variatore Ø 20x12

APPLICABILITÀ
MINARELLI / YAMAHA 250 CC

Codice	Peso
9918280	8
9918290	8,5
9918270	9
9918300	9,5

Codice	Peso
9918310	10
9918320	10,5
9918330	11
9918060	12

Codice	Peso
9918040	13
9918020	14



◀ Serie 6 masse variatore Ø 20x15

APPLICABILITÀ

KYMCO 125/150 - HONDA SH 125/150

Codice	Peso
9924280	9
9916650	10
9916670	11

Codice	Peso
9924320	12
9916690	13
9915820	13,5

Codice	Peso
9915150	14,5
9916710	15,5
9934170	17,5

◀ Serie 6 masse variatore Ø 20x17

APPLICABILITÀ

APRILIA - PEUGEOT E VARIATORI TOP PERFORMANCES "TPR" COD. 9923460 - 9923550 - 9923600 - 9923650

Codice	Peso
9922490	6,8
9922510	7,5
9916240	8
9916260	8,5
9923590	9
9915310	9,5

Codice	Peso
9923510	10
9922530	10,5
9916320	11
9924450	12
9922550	12,5
9922570	13

Codice	Peso
9922590	13,5
9923620	14
9922630	14,5
9922650	15
9922670	15,5
9922690	16

◀ Serie 6 masse variatore Ø 20,6x17,1

APPLICABILITÀ

APRILIA - GILERA - PIAGGIO

Codice	Peso
9932790	10,7



◀ Serie 6 masse variatore Ø 21x17,1

APPLICABILITÀ

APRILIA - GILERA - PIAGGIO

Codice	Peso
9931870	10,5

Codice	Peso
9931880	13,8



◀ Serie 6 masse variatore Ø 23x18

APPLICABILITÀ

HONDA - KYMCO E VARIATORI TOP PERFORMANCES "TPR" COD. 9923670 - 9923750 - 9923790

Codice	Peso
9931410	10
9931420	11
9916020	13
9916040	14

Codice	Peso
9923810	15
9924470	16
9931890	17,5
9916060	18

Codice	Peso
9932390	19
9916080	20
9916100	22
9915990	27

◀ Serie 6 masse variatore Ø 23,8x18

APPLICABILITÀ

SUZUKI

Codice	Peso
9918390	27

Codice	Peso
9918370	29

Codice	Peso
9918350	31



◀ Serie 8 masse variatore Ø 25x15

APPLICABILITÀ

YAMAHA

Codice	Peso
9924590	10
9924610	11
9924630	12
9924650	13

Codice	Peso
9922130	14
9922150	15
9922170	16
9922190	17

Codice	Peso
9922210	18
9922230	19
9922250	20



◀ Serie 8 masse variatore Ø 25x16 serigrafate

APPLICABILITÀ

PIAGGIO BEVERLY 4T 4V IE EU3 350 4T 11-14, BEVERLY 4T ST IE ABS 350 4T 16-20, MP3 MAXI SPORT E4 ABS 350 4T 4V 18-19, X10 4T 4V IE EURO3 350 4T 12-15

Codice	Peso
9937590	16

NOVITÀ

◀ Serie 8 masse variatore Ø 25x17

APPLICABILITÀ

PIAGGIO

Codice	Peso
9924490	14
9924510	15

Codice	Peso
9924530	16
9924550	17

Codice	Peso
9924570	20,5



◀ Serie 6 masse variatore Ø 25x22,10

APPLICABILITÀ

PIAGGIO

Codice	Peso
9922270	20
9922290	22

Codice	Peso
9922310	25
9922330	28,5

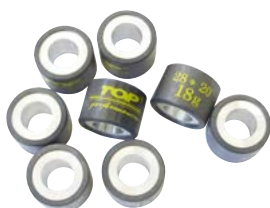

◀ Serie 8 masse variatore Ø 25x17

APPLICABILITÀ

APRILIA - GILERA - PIAGGIO

Codice	Peso
9935990	21,4

◀ Serie 8 masse variatore Ø 26x12,90

APPLICABILITÀ

SUZUKI

Codice	Peso
9922370	17
9922390	18

Codice	Peso
9922410	19
9918410	21

Codice	Peso
9922350	16
9922330	28,5

◀ Serie 8 masse variatore Ø 28x20

APPLICABILITÀ

HONDA SW-T 400 [FJS] 400 4T 09-13, Silver Wing 400 [FJS] 400 4T 06-08, SW-T 600 [FJS] 600 4T 11-13, Silver Wing 600 [FJS] 600 4T 01-10

Codice	Peso
9931810	18
9931820	20
9931830	22

Codice	Peso
9931840	25
9931860	28



◀ **cod. 9908010**
Serie 3 molle contrasto variatore per motori 50 cc Minarelli/Yamaha

◀ **cod. 9914440**
Molla contrasto variatore colore verde (carico 25 Kg)

◀ **cod. 9914430**
Molla contrasto variatore colore viola (carico 27 Kg)

◀ **cod. 9914420**
Molla contrasto variatore colore rosa (carico 29 Kg)

APPLICABILITÀ

APRILIA AMICO 50 2T 94-94, AMICO 50 2T 96-98, AMICO GL/GLE 50 2T 93-95, AMICO LX/SPORT/CAT 50 2T 92-93, AREA 51 50 2T 98-00, GULLIVER 50 2T 95-98, GULLIVER LC 50 2T 96-98, RALLY 50 2T 95-03, RALLY LIQUID COOLED 50 2T 96-99, SCARABEO 50 2T 93-05, SONIC 50 2T 98-07, SONIC GP 50 2T 98-08, SR (ORIZZONTALE) 50 2T 94-96, SR (VERTICALE) 50 2T 93-93, SR LIQUID COOLED 50 2T 94-96, SR RACING 50 2T 97-99, SR STEALTH 50 2T 97-00, SR WWW 50 2T 97-01

ATALA CAROSELLO 50 2T 99-01

BENELLI 491 GT 50 2T 98-99, 491 NAKED 50 2T 02-02, 491 RACING 50 2T 98-99, 491 RR 50 2T 99-01, 491 SP 50 2T 99-99, 491 SPORT 50 2T 98-99, 491 ST 50 2T 99-01, K2 50 2T 98-01, K2 LIQUID COOLED 50 2T 98-01, PEPE 50 2T 99-01, PEPE 50 2T 10-10, PEPE LX 50 2T 03-04, PEPE LX 50 2T 07-09, PEPE OLD 50 2T 07-09, PEPE OLD 50 2T 11-11, QUATTRONEVE 50 2T 08-11

BETA ARK 50 2T 96-08, ARK LC 50 2T 96-08, CHRONO 50 2T 95-96, EIKON 50 2T 99-03, QUADRA 50 2T 95-95, QUADRA 50 2T 99-01, TEMPO 50 2T 93-02, TEMPO 50 2T 95-95

CPI ARAGON 50 2T 03-03, HUSSAR 50 2T 03-03, OLIVER 50 2T 03-03, POP CORN 50 2T 03-03

EXPLORER CRACKER 50 2T 03-03

GARELLI GPS 50 2T 09-11

ITALJET DRAGSTER 50 2T 98-02

KEEWAY F-ACT 50 2T 07-08, FLASH 50 2T 07-08, FOCUS 50 2T 06-06, GOC-CIA 50 2T 09-09, HURRICANE 50 2T 06-08, MATRIX 50 2T 06-08, PIXEL EURO 2 50 2T 09-12, RV8 50 2T 08-08

KTM K50 50 2T 96-01

MACAL STING 50 2T 95-96, THUNDER 50 2T 95-96

MALAGUTI CENTRO SL 50 2T 94-98, CIAK 50 2T 99-01, CIAK EURO 2 2,3 50 2T 03-03, CIAK EURO2 50 2T 01-03, CIAK MASTER EURO 2 50 2T 06-06, F10 50 2T 92-00, F10 AC WAP 50 2T 08-08, F10 EURO 2 50 2T 02-06, F10 EURO 2,2,3 50 2T 03-04, F10 RESTYLING EURO 2 50 2T 06-06, F12 PHANTOM 50 2T 94-98, F12 PHANTOM EURO 2 50 2T 02-02, F12 PHANTOM EURO 2,2,3 50 2T 03-04, F12 PHANTOM LC 50 2T 94-98, F12 PHANTOM LC EURO 2,2,3 50 2T 03-04, F12 R PHANTOM AC 50 2T 07-08, F12 R PHANTOM LC 50 2T 07-10, F12 RESTYLING EURO 1 50 2T 99-02, F12 RESTYLING EURO 2 50 2T 06-06, F12 RESTYLING LC EURO 2 50 2T 06-06, F15 FIRE FOX 50 2T 96-98, F15 FIRE FOX AIR COOLED 50 2T 05-06, F15 FIRE FOX EURO 2 50 2T 02-06, F15 FIRE FOX EURO 2,2,3 50 2T 03-04, YESTERDAY 50 2T 97-00

MBK BOOSTER 50 2T 90-04, BOOSTER 50 2T 90-94, BOOSTER EURO 2 50 2T 04-04, BOOSTER NG 50 2T 95-03, BOOSTER ROCKET 50 2T 97-98, BOOSTER SPIRIT 50 2T 96-00, BOOSTER SPIRIT 50 2T 03-03, BOOSTER SPIRIT EURO2 50 2T 03-03, BOOSTER TRACK 50 2T 96-98, BOOSTER X IE 50 4T-3V 08-08, EVOLIS 50 2T 92-95, FIZZ 50 2T 94-95, FLIPPER 50 2T 98-04, FLIPPER EURO 2 50 2T 03-03, FORTE 50 2T 94-96, MACH G 50 2T 02-04, MACH G LC 50 2T 02-04, NITRO 50 2T 97-04, NITRO EURO 2 50 2T 03-03, OVETTO 50 2T 97-04, OVETTO 4T 50 4T-3V 09-11, OVETTO EURO 2 50 2T 02-02, STUNT 50 2T 00-02

MOTRON STING 50 2T 95-96, SYNCRO 50 2T 98-00, THUNDER 50 2T 95-98

PGO BIG MAX 50 2T 95-97

RIEJU FIRST 50 2T 95-98, WINDY 50 2T 95-98

YAMAHA AEROX 50 2T 97-02, AEROX 50 2T 04-16, AEROX EURO 2 50 2T 03-03, AEROX NAKED 50 2T 13-16, AEROX R 50 2T 99-00, AXIS 50 2T 95-96, BREEZE 50 2T 94-95, BW'S 50 2T 97-16, BW'S BUMP 50 2T 97-98, BW'S EASY 50 2T 13-13, BW'S NAKED 50 2T 03-04, BW'S NAKED 50 2T 09-16, BW'S NEXT GENERATION 50 2T 97-06, BW'S ORIGINAL 50 2T 99-01, BW'S ORIGINAL EURO 2 50 2T 03-03, GIGGLE 50 4T-3V 08-08, JOG R 50 2T 02-02, JOG R EURO2 50 2T 02-02, JOG R EURO2 50 2T 06-15, JOG R LC 50 2T 02-15, NEO'S 50 2T 97-02, NEO'S 50 2T 04-16, NEO'S 4 50 4T-3V 09-15, NEO'S EASY 50 2T 13-13, NEO'S EURO 2 50 2T 02-02, RS SPY 50 2T 95-98, SLIDER 50 2T 00-02, WHY 50 2T 98-05, WHY EURO 2 50 2T 03-05, ZEST 50 2T 95-92, ZUMA 50 2T 97-01



◀ **cod. 9908470**
Serie 3 molle contrasto variatore per motori 50 cc Gilera/Piaggio

◀ **cod. 9914800**
Molla contrasto variatore colore verde (carico 35 Kg)

◀ **cod. 9914810**
Molla contrasto variatore colore viola (carico 37,5 Kg)

◀ **cod. 9914820**
Molla contrasto variatore colore rosa (carico 39,5 Kg)

APPLICABILITÀ

APRILIA MOJITO CUSTOM 2T MOTORE PIAGGIO 50 2T 04-10, SCARABEO 2T EU2 MOTORE PIAGGIO 50 2T 10-12, SCARABEO 2T NET 50 2T 09-10, SCARABEO 4T 50 4T 02-06, SCARABEO 4T 4V 50 4T-4V 10-12, SCARABEO 4T 4V NET 50 4T-4V 09-10, SCARABEO 4T RESTYLING EU3 50 4T 06-09, SCARABEO QUATTRO 50 4T-4V 09-09, SCARABEO STREET 50 2T 05-06, SCARABEO STREET 2T RESTYLING 50 2T 06-09, SPORT CITY ONE 2T 50 2T 08-11, SPORT CITY ONE 4T 50 4T 08-10, SR MOTARD 50 2T 12-14, SR R 50 2T 04-09, SR R FACTORY CARBURATORE 50 2T 10-14, SR R FACTORY IE 50 2T 10-14, SR STREET CARBURATORE 50 2T 03-12

DERBI ATLANTIS 2T 50 2T 10-10, ATLANTIS 2T EU2 50 2T 07-09, ATLANTIS 4T 50 4T 04-06, ATLANTIS 4T EU2 50 4T 07-07, ATLANTIS O2 50 2T 02-02, ATLANTIS O2 BULLET 50 2T 03-05, ATLANTIS O2 CITY 50 2T 04-06, ATLANTIS O2 RED BULLET 50 2T 03-03, ATLANTIS O2 TWO CHIC 50 2T 05-05, BOULEVARD 2T 50 2T 09-14, BOULEVARD 4T EU2 25KM/H 50 4T 09-09, GP1 50 2T 01-03, GP1 EU 2 50 2T 05-05, GP1 OPEN EU2 50 2T 06-09, GP1 RACE EU2 50 2T 05-07, SONAR 2T 50 2T 09-09

GILERA DNA 50 2T 00-02, DNA 50 2T 05-07, DNA GP EXPERIENCE 50 2T 03-04, EASY MOVING 50 2T 95-96, ICE 50 2T 01-05, RUNNER 50 2T 97-00, RUNNER POGGIALI 50 2T 02-02, RUNNER PURE JET 50 2T-IE 02-07, RUNNER PURE JET 50 2T-IE 10-11, RUNNER PURE JET ST 50 2T-IE 08-08, RUNNER SP 50 2T 02-07, RUNNER SP 50 2T 10-12, RUNNER SP SPECIAL EDITION 50 2T 07-07, RUNNER SP ST & SIMONCELLI 50 2T 08-09, STALKER 50 2T 97-11, STALKER NAKED 50 2T 08-08, STALKER SPECIAL EDITION 50 2T 07-08, STORM 50 2T 94-95, STORM EURO 2 50 2T 07-07, TYPHOON 50 2T 94-97, TYPHOON X 50 2T 98-99, TYPHOON XR 50 2T 00-00

ITALJET JET SET 50 2T 02-02, TORPEDO 50 4T 97-00, TORPEDO NEW 50 2T 00-01

MALAGUTI CENTRO EURO 2 50 4T 08-08, CENTRO SL 4T 50 4T 10-10, CIAK MASTER 4T 50 4T 05-06, CIAK MASTER EURO 2 50 4T 05-06

PIAGGIO DIESIS 50 2T 01-01, FLY 2T 50 2T 05-07, FLY 2T 50 2T 10-11, FLY 4T 50 4T 05-07, FLY 4T & 25-30 KM/H 50 4T 08-11, FLY 4T MOTORE CHN 50 4T 06-07, FREE 50 2T 92-94, FREE DELIVERY 50 2T 00-01, FREE FL 50 2T 95-02, LIBERTY 50 2T 97-05, LIBERTY 2T 50 2T 06-08, LIBERTY 2T PTT EU2 50 2T 04-05, LIBERTY 2T RST 50 2T 04-04, LIBERTY 2T SPORT 50 2T 06-08, LIBERTY 4T 50 4T 00-02, LIBERTY 4T 50 4T 05-08, LIBERTY 4T 3V IE 50 4T-3V 15-17, LIBERTY 4T 3V IE E4 50 4T-3V 17-18, LIBERTY 4T DELIVERY - SINGLE 50 4T 10-14, LIBERTY 4T DELIVERY TNT 50 4T 09-09, LIBERTY 4T PTT - DOUBLE - NEXIVE 50 4T 09-17, LIBERTY 4T RST 50 4T 04-04,

LIBERTY 4T SPORT 50 4T 06-08, LIBERTY MOC 2T & ELLE 50 2T 09-13, LIBERTY MOC 4T & ELLE 50 4T 09-16, NRG 50 2T 94-96, NRG EXTREME LC 50 2T 99-00, NRG MC3 50 2T 01-04, NRG POWER DD 50 2T 05-17, NRG POWER DD SERIE SPECIALE 50 2T 07-12, NRG POWER DT 50 2T 06-15, NRG POWER DT SERIE SPECIALE 50 2T 07-08, NRG POWER PUREJET 50 2T-IE 04-11, NRG PUREJET 50 2T-IE 02-04, NRG PUREJET 50 2T-IE 10-10, NRG RST MC2 50 2T 96-98, NTT 50 2T 95-96, QUARTZ 50 2T 92-96, SFERA 50 2T 91-93, SFERA MAQUILLAGE 2 50 2T 94-94, SFERA RST 50 2T 95-97, TYPHOON 50 2T 01-11, TYPHOON 2T E2 50 2T 10-12, TYPHOON 2T E3 CH 50 2T 11-11, VESPA ET2 50 2T 97-05, VESPA ET2 INIEZIONE 50 2T 97-00, VESPA ET4 50 4T 00-05, VESPA LX 2T 50 2T 05-13, VESPA LX 2T TOURING & 30KM 50 2T 10-13, VESPA LX 4T 50 4T 05-09, VESPA LX 4T 4V 50 4T-4V 09-13, VESPA LX 4T 4V TOURING 50 4T-4V 10-13, VESPA LXV 2T 50 2T 06-09, VESPA LXV 2T NAVY 50 2T 08-08, VESPA S 2T & COLLEGE 50 2T 07-12, VESPA S 4T 4V & COLLEGE 50 4T-4V 08-12, ZIP 50 2T 92-93, ZIP 50 2T 95-96, ZIP 2T 50 2T 08-13, ZIP 4T 50 4T 00-13, ZIP BIMODALE 50 2T 94-97, ZIP FAST RIDER 50 2T 93-94, ZIP FAST RIDER RST 50 2T 96-97, ZIP LC 50 2T 00-04, ZIP RST 50 2T 96-99, ZIP SP 50 2T 96-04, ZIP SP EURO 2 50 2T 06-13

MOLLE CONTRASTO VARIATORE

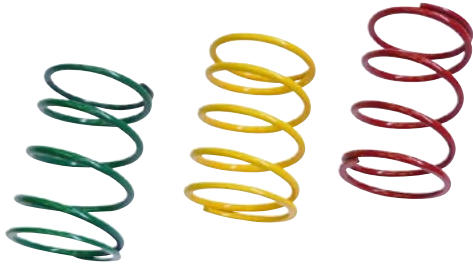

cod. **9925630**

RACING

Serie 3 molle contrasto variatore per motori 50 cc Gilera/Piaggio Racing

cod. **9914450**

Molla contrasto variatore colore giallo (carico 37 Kg)

cod. **9914460**

Molla contrasto variatore colore verde (carico 41 Kg)

cod. **9924970**

Molla contrasto variatore colore rosso (carico 46 Kg)

APPLICABILITÀ

APRILIA MOJITO CUSTOM 2T MOTORE PIAGGIO 50 2T 04-10, SCARABEO 2T EU2 MOTORE PIAGGIO 50 2T 10-12, SCARABEO 2T NET 50 2T 09-10, SCARABEO 4T 50 4T 02-06, SCARABEO 4T 4V 50 4T 4V 10-12, SCARABEO 4T 4V NET 50 4T 4V 09-10, SCARABEO 4T RESTYLING EU3 50 4T 06-09, SCARABEO QUATTRO 50 4T 4V 09-09, SCARABEO STREET 50 2T 05-06, SCARABEO STREET 2T RESTYLING 50 2T 06-09, SPORT CITY ONE 2T 50 2T 08-11, SPORT CITY ONE 4T 50 4T 08-10, SR MOTARD 50 2T 12-14, SR R 50 2T 04-09, SR R FACTORY CARBURATORE 50 2T 10-14, SR R FACTORY IE 50 2T 10-14, SR STREET CARBURATORE 50 2T 03-12

DERBI ATLANTIS 2T 50 2T 10-10, ATLANTIS 2T EU2 50 2T 07-09, ATLANTIS 4T 50 4T 04-06, ATLANTIS 4T EU2 50 4T 07-07, ATLANTIS 02 50 2T 02-02, ATLANTIS 02 BULLET 50 2T 03-05, ATLANTIS 02 CITY 50 2T 04-06, ATLANTIS 02 RED BULLET 50 2T 03-03, ATLANTIS 02 TWO CHIC 50 2T 05-05, BOULEVARD 2T 50 2T 09-14, BOULEVARD 4T EU2 25KM/H 50 4T 09-09, GP1 50 2T 01-03, GP1 EU 2 50 2T 05-05, GP1 OPEN EU2 50 2T 06-09, GP1 RACE EU2 50 2T 05-07, SONAR 2T 50 2T 09-09

GILERA DNA 50 2T 00-02, DNA 50 2T 05-07, DNA GP EXPERIENCE 50 2T 03-04, EASY MOVING 50 2T 95-96, ICE 50 2T 01-05, RUNNER 50 2T 97-00, RUNNER POGGIALI 50 2T 02-02, RUNNER PURE JET 50 2T-IE 02-07, RUNNER PURE JET 50 2T-IE 10-11, RUNNER PURE JET ST 50 2T-IE 08-08, RUNNER SP 50 2T 02-07, RUNNER SP 50 2T 10-12, RUNNER SP SPECIAL EDITION 50 2T 07-07, RUNNER SP ST & SIMONCELLI 50 2T 08-09, STALKER 50 2T 97-11, STALKER NAKED 50 2T 08-08, STALKER SPECIAL EDITION 50 2T 07-08, STORM 50 2T 94-95, STORM EURO 2 50 2T 07-07, TYPHOON 50 2T 94-97, TYPHOON X 50 2T 98-99, TYPHOON XR 50 2T 00-00

ITALJET JET SET 50 2T 02-02, TORPEDO 50 4T 97-00, TORPEDO NEW 50 2T 00-01

MALAGUTI CENTRO EURO 2 50 4T 08-08, CENTRO SL 4T 50 4T 10-10, CIAK MASTER 4T 50 4T 05-06, CIAK MASTER EURO 2 50 4T 05-06

PIAGGIO DIESIS 50 2T 01-01, FLY 2T 50 2T 05-07, FLY 2T 50 2T 10-11, FLY 4T 50 4T 05-07, FLY 4T & 25-30 KM/H 50 4T 08-11, FLY 4T MOTORE CHN 50 4T 06-07, FREE 50 2T 92-94, FREE DELIVERY 50 2T 00-01, FREE FL 50 2T 95-02, LIBERTY 50 2T 97-05, LIBERTY 2T 50 2T 06-08, LIBERTY 2T PTT EU2 50 2T 04-05, LIBERTY 2T RST 50 2T 04-04, LIBERTY 2T SPORT 50 2T 06-08, LIBERTY 4T 50 4T 00-02, LIBERTY 4T 50 4T 05-08, LIBERTY 4T 3V IE 50 4T 3V 15-17, LIBERTY 4T 3V IE E4 50 4T 3V 17-18, LIBERTY 4T DELIVERY - SINGLE 50 4T 10-14, LIBERTY 4T DELIVERY TNT 50 4T 09-09, LIBERTY 4T PTT - DOUBLE - NEXIVE 50 4T 09-17, LIBERTY 4T RST 50 4T 04-04, LIBERTY 4T SPORT 50 4T 06-08, LIBERTY MOC 2T & ELLE 50 2T 09-13, LIBERTY MOC 4T & ELLE 50 4T 09-16, NRG 50 2T 94-96, NRG EXTREME LC 50 2T 99-00, NRG MC3 50 2T 01-04, NRG POWER DD 50 2T 05-17, NRG POWER DD SERIE SPECIALE 50 2T 07-12, NRG POWER DT 50 2T 06-15, NRG POWER DT SERIE SPECIALE 50 2T

07-08, NRG POWER PUREJET 50 2T-IE 04-11, NRG PUREJET 50 2T-IE 02-04, NRG PUREJET 50 2T-IE 10-10, NRG RST MC2 50 2T 96-98, NTT 50 2T 95-96, QUARTZ 50 2T 92-96, SFERA 50 2T 91-93, SFERA MAQUILLAGE 2 50 2T 94-94, SFERA RST 50 2T 95-97, TYPHOON 50 2T 01-11, TYPHOON 2T E2 50 2T 10-12, TYPHOON 2T E3 CH 50 2T 11-11, VESPA ET2 50 2T 97-05, VESPA ET2 INIEZIONE 50 2T 97-00, VESPA ET4 50 4T 00-05, VESPA LX 2T 50 2T 05-13, VESPA LX 2T TOURING & 30KM 50 2T 10-13, VESPA LX 4T 50 4T 05-09, VESPA LX 4T 4V 50 4T 4V 09-13, VESPA LX 4T 4V TOURING 50 4T 4V 10-13, VESPA LXV 2T 50 2T 06-09, VESPA LXV 2T NAVY 50 2T 08-08, VESPA S 2T & COLLEGE 50 2T 07-12, VESPA S 4T 4V & COLLEGE 50 4T 4V 08-12, ZIP 50 2T 92-93, ZIP 50 2T 95-96, ZIP 2T 50 2T 08-13, ZIP 4T 50 4T 00-13, ZIP BIMODALE 50 2T 94-97, ZIP FAST RIDER 50 2T 93-94, ZIP FAST RIDER RST 50 2T 96-97, ZIP LC 50 2T 00-04, ZIP RST 50 2T 96-99, ZIP SP 50 2T 96-04, ZIP SP EURO 2 50 2T 06-13

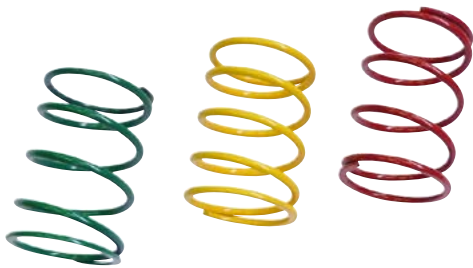

cod. **9925620**

RACING

Serie 3 molle contrasto variatore per motori 50 cc Minarelli/Yamaha Racing

cod. **9914470**

Molla contrasto variatore colore giallo (carico 26 kg)

cod. **9914480**

Molla contrasto variatore colore verde (carico 29 kg)

cod. **9924840**

Molla contrasto variatore colore rosso (carico 32 kg)

APPLICABILITÀ

APRILIA AMICO 50 2T 94-94, AMICO 50 2T 96-98, AMICO GL/GLE 50 2T 93-95, AMICO LX/SPORT/CAT 50 2T 92-93, AREA 51 50 2T 98-00, GULLIVER 50 2T 95-98, GULLIVER LC 50 2T 96-98, RALLY 50 2T 95-03, RALLY LIQUID COOLED 50 2T 96-99, SCARABEO 50 2T 93-05, SONIC 50 2T 98-07, SONIC GP 50 2T 98-08, SR (ORIZZONTALE) 50 2T 94-96, SR (VERTICALE) 50 2T 93-93, SR LIQUID COOLED 50 2T 94-96, SR RACING 50 2T 97-99, SR STEALTH 50 2T 97-00, SR WWW 50 2T 97-01

ATALA CAROSELLO 50 2T 99-01

BENELLI 491 GT 50 2T 98-99, 491 NAKED 50 2T 02-02, 491 RACING 50 2T 98-99, 491 RR 50 2T 99-01, 491 SP 50 2T 99-99, 491 SPORT 50 2T 98-99, 491 ST 50 2T 99-01, K2 50 2T 98-01, K2 LIQUID COOLED 50 2T 98-01, PEPE 50 2T 99-01, PEPE 50 2T 10-10, PEPE LX 50 2T 03-04, PEPE LX 50 2T 07-09, PEPE OLD 50 2T 07-09, PEPE OLD 50 2T 11-11, QUATRONONEX 50 2T 08-11

BETA ARK 50 2T 96-08, ARK LC 50 2T 96-08, CHRONO 50 2T 95-96, EIKON 50 2T 99-03, QUADRA 50 2T 95-95, QUADRA 50 2T 99-01, TEMPO 50 2T 93-02, TEMPO 50 2T 95-95

CPI ARAGON 50 2T 03-03, HUSSAR 50 2T 03-03, OLIVER 50 2T 03-03, POP CORN 50 2T 03-03

EXPLORER CRACKER 50 2T 03-03

GARELLI GPS 50 2T 09-11

ITALJET DRAGSTER 50 2T 98-02

KEEWAY F-ACT 50 2T 07-08, FLASH 50 2T 07-08, FOCUS 50 2T 06-06, GOC-CIA 50 2T 09-09, HURRICANE 50 2T 06-08, MATRIX 50 2T 06-08, PIXEL EURO 2 50 2T 09-12, RY8 50 2T 08-08

KTM K50 50 2T 96-01

MACAL STING 50 2T 95-96, THUNDER 50 2T 95-96

MALAGUTI CENTRO SL 50 2T 94-98, CIAK 50 2T 99-01, CIAK EURO 2, 2,3 50 2T 03-03, CIAK EURO2 50 2T 01-03, CIAK MASTER EURO 2 50 2T 06-06, F10 50 2T 92-00, F10 AC WAP 50 2T 08-08, F10 EURO 2 50 2T 02-06, F10 EURO 2, 2,3 50 2T 03-04, F10 RESTYLING EURO 2 50 2T 06-06, F12 PHANTOM 50 2T 94-98, F12 PHANTOM EURO 2 50 2T 02-02, F12 PHANTOM EURO 2, 2,3 50 2T 03-04, F12 PHANTOM LC 50 2T 94-98, F12 PHANTOM LC EURO 2, 2,3 50 2T 03-04, F12 R PHANTOM AC 50 2T 07-08, F12 R PHANTOM LC 50 2T 07-10, F12 RESTYLING EURO 1 50 2T 99-02, F12 RESTYLING EURO 2 50 2T 06-06, F12 RESTYLING LC EURO 2 50 2T 06-06, F15 FIRE FOX 50 2T 96-98, F15 FIRE FOX AIR COOLED 50 2T 05-06, F15 FIRE FOX EURO 2 50 2T 02-06, F15 FIRE FOX EURO 2, 2,3 50 2T 03-04, YESTERDAY 50 2T 97-00

MBK BOOSTER 50 2T 90-04, BOOSTER 50 2T 90-94, BOOSTER EURO 2 50 2T 04-04, BOOSTER NG 50 2T 95-03, BOOSTER ROCKET 50 2T 97-98, BOOSTER SPIRIT 50 2T 96-00, BOOSTER SPIRIT 50 2T 03-03, BOOSTER SPIRIT EURO2 50 2T 03-03, BOOSTER TRACK 50 2T 96-98, BOOSTER XIE 50 4T 3V 08-08, EVOLIS 50 2T 92-95, FIZZ 50 2T 94-95, FLIPPER 50 2T 98-04, FLIPPER EURO 2 50 2T 03-03, FORTE 50 2T 94-96, MACH G 50 2T 02-04, MACH G LC 50 2T 02-04, NITRO 50 2T 97-04, NITRO EURO 2 50 2T 03-03, OVETTO 50 2T 97-04, OVETTO 50 4T 3V 09-11, OVETTO EURO 2 50 2T 02-02, STUNT 50 2T 00-02

MOTRON STING 50 2T 95-96, SYNCRO 50 2T 98-00, THUNDER 50 2T 95-98

PGO BIG MAX 50 2T 95-97

RIEJU FIRST 50 2T 95-98, WINDY 50 2T 95-98

YAMAHA AEROX 50 2T 97-02, AEROX 50 2T 04-16, AEROX EURO 2 50 2T 03-03, AEROX NAKED 50 2T 13-16, AEROX R 50 2T 99-00, AXIS 50 2T 95-96, BREEZE 50 2T 94-95, BW'S 50 2T 97-16, BW'S BUMP 50 2T 97-98, BW'S EASY 50 2T 13-13, BW'S NAKED 50 2T 03-04, BW'S NAKED 50 2T 09-16, BW'S NEXT GENERATION 50 2T 97-06, BW'S ORIGINAL 50 2T 99-01, BW'S ORIGINAL EURO 2 50 2T 03-03, GIGGLE 50 4T 3V 08-08, JOG R 50 2T 02-02, JOG R EURO2 50 2T 02-02, JOG R EURO2 50 2T 06-15, JOG R LC 50 2T 02-15, NEO'S 50 2T 97-02, NEO'S 50 2T 04-16, NEO'S 4 50 4T 3V 09-15, NEO'S EASY 50 2T 13-13, NEO'S EURO 2 50 2T 02-02, RS SPY 50 2T 95-98, SLIDER 50 2T 00-02, WHY 50 2T 98-05, WHY EURO 2 50 2T 03-05, ZEST 50 2T 95-92, ZUMA 50 2T 97-01



◀ **cod. 9914750**
Molla contrasto variatore colore verde per motori 50 cc Suzuki (carico 35,5 kg)

APPLICABILITÀ

ATALA HACKER 50 2T 95-00, HACKER LC 50 2T 95-00, VAMOS 50 2T 93-95
BENELLI 491 RR MORINI 50 2T 03-04, 491 ST MORINI 50 2T 03-03, NAKED MORINI 50 2T 03-04
ITALJET FORMULA 50 2T 94-97, FORMULA LC 50 2T 94-97, VELOCIFERO 50 2T 98-02

MALAGUTI CROSSER CR1 50 2T 95-98
SUZUKI AH ADDRESS 50 2T 92-95, AJ ZZ 50 2T 95-97, AP 50 2T 94-97, ESTILETE UF 50 2T 00-00, KATANA K1-K4 50 2T 01-04, KATANA V-Y 50 2T 97-00, STREET MAGIC 50 2T 98-98, ZILLION UX 50 2T 99-99



◀ **cod. 9914760**
Molla contrasto variatore colore rosa per motori 50 cc Suzuki (carico 40 kg)

APPLICABILITÀ

ATALA HACKER 50 2T 95-00, HACKER LC 50 2T 95-00, VAMOS 50 2T 93-95
BENELLI 491 RR MORINI 50 2T 03-04, 491 ST MORINI 50 2T 03-03, NAKED MORINI 50 2T 03-04
ITALJET FORMULA 50 2T 94-97, FORMULA LC 50 2T 94-97, VELOCIFERO 50 2T 98-02

MALAGUTI CROSSER CR1 50 2T 95-98
SUZUKI AH ADDRESS 50 2T 92-95, AJ ZZ 50 2T 95-97, AP 50 2T 94-97, ESTILETE UF 50 2T 00-00, KATANA K1-K4 50 2T 01-04, KATANA V-Y 50 2T 97-00, STREET MAGIC 50 2T 98-98, ZILLION UX 50 2T 99-99



◀ **cod. 9926760**
Molla contrasto variatore colore giallo per Yamaha X-Max 125 cc (carico 44 kg)

APPLICABILITÀ

MBK CITYLINER EU3 125 4T-4V 08-10, SKYCRUISER 125 4T-4V 07-07
YAMAHA X-CITY EU3 125 4T-4V 08-11, X-MAX R 125 4T-4V 06-16, X-MAX R ABS 125 4T-4V 11-11, X-MAX RA ABS 125 4T-4V 13-16

◀ **cod. 9926770**
Molla contrasto variatore colore bianco per Honda SH 125/150 cc (carico 44,5 kg)

APPLICABILITÀ

HONDA @ [NES] 125 4T 00-06, DYLAN [SES] 125 4T 02-04, PANTHEON IE [FES] 125 4T-2V 03-05, PS I [PES] 125 4T 06-10, SH 125 4T-2V 01-04, SH IE SCOOPY 125 4T-2V 05-12, SILVER WING [FES] 125 4T-2V 07-12, @ [NES] 150 4T 00-06, DYLAN [SES] 150 4T 02-04, PANTHEON IE [FES] 150 4T-2V 03-05, PS I [PES] 150 4T 06-10, SH 150 4T-2V 01-04, SH IE SCOOPY 150 4T 05-12, SILVER WING [FES] 150 4T-2V 07-12

KEEWAY OUTLOOK 125 4T 07-08, OUTLOOK 150 4T 07-08

◀ **cod. 9926780**
Molla contrasto variatore colore bianco per Piaggio 500 cc (carico 78 kg)

APPLICABILITÀ

APRILIA ATLANTIC ARRECIFE 400 4T 05-08, ATLANTIC SPRINT 400 4T 05-08, SCARABEO LIGHT 400 4T 06-08, ATLANTIC 500 4T 01-04, ATLANTIC ARRECIFE 500 4T 05-08, ATLANTIC SPRINT 500 4T 05-08, SCARABEO 500 4T 03-06, SCARABEO LIGHT 500 4T 06-08
GILERA NEXUS 500 4T 03-05
MALAGUTI SPIDER MAX GT 500 4T 04-05, SPIDER MAX GT EU3 500 4T 06-06, SPIDER MAX RS 500 4T 08-08
PEUGEOT GEOPOLIS IE EU3 400 4T-4V 90-02, SATELIS EU3 400 4T 07-12, GEOPOLIS IE EU3 500 4T-4V 90-02, SATELIS EU3 500 4T 90-02

PIAGGIO BEVERLY EU3 400 4T 06-07, BEVERLY TOURER EU3 400 4T 08-10, MP3 400 4T 07-08, MP3 IE LT TOURING 400 4T 11-11, MP3 IE LT/SPORT 400 4T 08-10, MP3 MIC 400 4T 08-10, MP3 RL TOURING 400 4T 11-11, X-EVO 400 4T 07-11, X8 EU3 400 4T 06-08, BEVERLY 500 4T 02-06, BEVERLY CRUISER 500 4T 07-12, BEVERLY IE EU3 500 4T 06-08, MP3 LT SPORT/BUSINESS 500 4T 11-13, MP3 RL SPORT-BUSINESS 500 4T 11-12, X9 500 4T 01-02, X9 EVOLUTION 500 4T 03-07, X9 EVOLUTION ABS 500 4T 06-07

◀ **cod. 9926790**

Molla contrasto variatore colore bianco per Suzuki Burgman 400 cc (carico 67 kg)

APPLICABILITÀ

SUZUKI AN Burgman 400 K3/K6 400 4T 03-06, AN Burgman 400 K7/LO 400 4T 07-10

◀ **cod. 9926800**

Molla contrasto variatore colore bianco per Honda Foresight 250 cc (carico 59 kg)

APPLICABILITÀ

HONDA Foresight 250 [FES] D.D. 250 4T 00-05, Forza 250 [NSS] 250 4T-2V 02-07, Forza X 250 [NSS] 250 4T-2V 05-07, Jazz 250 ES Reflex [NSS] 250 4T-2V 01-04, Jazz 250 Reflex [NSS] 250 4T-2V 01-01

◀ **cod. 9929170**

Molla contrasto variatore colore bianco per Yamaha Majesty 125/150 cc (carico 39 kg)

APPLICABILITÀ

BENELLI	VELVET 125 4T 99-01, VELVET 150 4T 99-01	MBK	DOODO 125 4T 00-00, SKYLINER 125 4T 98-02, SKYLINER E 125 4T 03-03, THUNDER 125 4T 01-02, DOODO 150 4T 01-02, SKYLINER 150 4T 00-02, THUNDER 150 4T 01-02
ITALJET	JUPITER 125 4T 01-02, MILLENIUM 125 4T 00-02, JUPITER 150 4T 01-02, MILLENIUM 150 4T 00-02	YAMAHA	MAJESTY 125 4T 98-00, MAJESTY (5NR1) 125 4T 01-01, MAJESTY (5NR8) 125 4T 02-02, MAJESTY E 125 4T 03-09, MAXSTER 125 4T 01-02, TEO'S 125 4T 00-00, MAJESTY 150 4T 00-00, MAJESTY (SNS1) 150 4T 01-01, MAJESTY (SNS6) 150 4T 02-02, MAXSTER 150 4T 01-02, TEO'S 150 4T 01-02
MALAGUTI	MADISON 125 4T 99-01, MADISON R RESTYLING 125 4T 02-02, MADISON R RESTYLING EU2 125 4T 03-04, PHANTOM MAX 125 4T 03-03, MADISON T 150 4T 99-01		



◀ **cod. 9929870**

Molla contrasto variatore colore giallo per Yamaha X-Max 250 cc (carico 56 kg)

APPLICABILITÀ

APRILIA	LEONARDO 250 4T 99-04, LEONARDO ST 250 4T 01-01	MBK	SKYLINER 250 4T 00-03, SKYLINER ABS 250 4T 03-03
BENELLI	VELVET 250 4T 99-03	YAMAHA	MAJESTY 250 4T 96-03, MAJESTY ABS 250 4T 03-03, MAJESTY DX 250 4T 98-99, X-CITY 250 4T 07-15, X-MAX 250 4T 05-16, X-MAX ABS 250 4T 14-15
ITALJET	JUPITER 250 4T 00-02		
MALAGUTI	MADISON S 250 4T 99-01, PASSWORD 250 4T 05-06, PASSWORD EU3 250 4T 07-08		

◀ **cod. 9929880**

Molla contrasto variatore colore giallo per Yamaha T-Max 500 cc (carico 93,5 kg)

APPLICABILITÀ

YAMAHA T-MAX 4BS 500 4T 09-11, T-MAX 4BS ABS 500 4T 08-11, T-MAX 5GJ 500 4T 01-03, T-MAX 5VU 500 4T 04-08, T-MAX 5VU ABS 500 4T 05-07, T-MAX 5VU BLACK MAX 500 4T 06-06, T-MAX 5VU BLACK MAX - NIGHT MAX 500 4T 07-07, T-MAX 59C 530 4T 12-16, T-MAX 59C ABS 530 4T 12-16, T-MAX 59C SP 530 4T 15-15, T-MAX 59C SP ABS 530 4T 15-16, XP530-A T-MAX SX 530 4T 17-19, XP530D-A T-MAX DX 530 4T 17-19, XP530E-A T-MAX 530 4T 17-18

◀ **cod. 9929890**

Molla contrasto variatore colore giallo per Honda SH 300 cc (carico 68 kg)

APPLICABILITÀ

HONDA SH IE SCOOPY 300 4T-4V 07-19



cod. 9908240

Set 3 serie molle per frizione a 2 ceppi con campana Ø interno 105 mm, carico differenziato

Codice	Colore	Carico kg
9908100	VERDE	8
9908220	VIOLA	10,5
9908230	ROSA	12,8

APPLICABILITÀ

APRILIA AMICO 50 2T 94-94, AMICO 50 2T 96-98, AMICO GL/GLE 50 2T 93-95, AMICO LX/SPORT/CAT 50 2T 92-93, AREA 51 50 2T 98-00, GULLIVER 50 2T 95-98, GULLIVER LC 50 2T 96-98, RALLY 50 2T 95-03, RALLY LIQUID COOLED 50 2T 96-99, SCARABEO 50 2T 93-05, SONIC 50 2T 98-07, SONIC GP 50 2T 98-08, SR (ORIZZONTALE) 50 2T 94-96, SR (VERTICALE) 50 2T 93-93, SR LIQUID COOLED 50 2T 94-96, SR RACING 50 2T 97-99, SR STEALTH 50 2T 97-00, SR WWW 50 2T 97-01

ATALA CAROSELLO 50 2T 99-01

BENELLI 491 GT 50 2T 98-99, 491 NAKED 50 2T 02-02, 491 RACING 50 2T 98-99, 491 RR 50 2T 99-01, 491 SP 50 2T 99-99, 491 SPORT 50 2T 98-99, 491 ST 50 2T 99-01, K2 50 2T 98-01, K2 LIQUID COOLED 50 2T 98-01, PEPE 50 2T 99-01, PEPE 50 2T 10-10, PEPE LX 50 2T 03-04

BETA ARK 50 2T 96-08, ARK LC 50 2T 96-08, CHRONO 50 2T 95-96, EIKON 50 2T 99-03, QUADRA 50 2T 95-95, QUADRA 50 2T 99-01, TEMPO 50 2T 93-02, TEMPO 50 2T 95-95

ITALJET BAZOOKA 50 2T 91-94, DRAGSTER 50 2T 98-02, PISTA 50 2T 92-97, PISTA 2 50 2T 97-98, SCOOP 50 2T 91-95, SCOOP 2 50 2T 96-98, YANKEE 50 2T 93-97

KTM K50 50 2T 96-01

MACAL THUNDER 50 2T 95-96

MALAGUTI CENTRO SL 50 2T 94-98, CIAK 50 2T 99-01, CIAK EURO 2,2,3 50 2T 03-03, CIAK EURO2 50 2T 01-03, F10 50 2T 92-00, F10 EURO 2 50 2T 02-06, F10 EURO 2,2,3 50 2T 03-04, F12 PHANTOM 50 2T 94-98, F12 PHANTOM EURO 2,2,3 50 2T 03-04, F12 PHANTOM LC 50 2T 94-98, F12 PHANTOM LC EURO 2,2,3 50 2T 03-04, F12 RESTYLING EURO 2 50 2T 06-06, F15 FIRE FOX 50 2T 96-98, F15 FIRE FOX EURO 2 50 2T 02-03, F15 FIRE FOX EURO 2,2,3 50 2T 03-04, YESTERDAY 50 2T 97-00

MBK BOOSTER 50 2T 90-04, BOOSTER 50 2T 90-94, BOOSTER EURO 2 50 2T 04-04, BOOSTER NG 50 2T 95-03, BOOSTER ROCKET 50 2T 97-98, BOOSTER SPIRIT 50 2T 96-00, BOOSTER SPIRIT 50 2T 03-03, BOOSTER SPIRIT EURO2 50 2T 03-03, BOOSTER TRACK 50 2T 96-98, FLIPPER 50 2T 98-04, FLIPPER EURO 2 50 2T 03-03, MACH G 50 2T 02-04, MACH G LC 50 2T 02-04, NITRO 50 2T 97-04, NITRO EURO 2 50 2T 03-03, OVETTO 50 2T 97-04, OVETTO EURO 2 50 2T 02-02, SORRISO 50 2T 95-96, STUNT 50 2T 00-02, TARGET 50 2T 91-95

MOTRON SYNCRO 50 2T 98-00, THUNDER 50 2T 95-98

RIEJU FIRST 50 2T 95-98, WINDY 50 2T 95-98

YAMAHA AEROX 50 2T 97-02, AEROX 50 2T 04-16, AEROX EURO 2 50 2T 03-03, AEROX NAKED 50 2T 13-16, AEROX R 50 2T 99-00, BW'S 50 2T 97-16, BW'S BUMP 50 2T 97-98, BW'S EASY 50 2T 13-13, BW'S NAKED 50 2T 03-04, BW'S NAKED 50 2T 09-16, BW'S NEXT GENERATION 50 2T 97-06, BW'S ORIGINAL 50 2T 99-01, BW'S ORIGINAL EURO 2 50 2T 03-03, CRZ 50 2T 91-95, CT 50 2T 90-95, JOG R 50 2T 02-02, JOG R EURO2 50 2T 02-02, JOG R EURO2 50 2T 06-15, JOG R LC 50 2T 02-15, NEO'S 50 2T 97-02, NEO'S 50 2T 04-16, NEO'S EASY 50 2T 13-13, NEO'S EURO 2 50 2T 02-02, RS SPY 50 2T 95-98, SLIDER 50 2T 00-02, WHY 50 2T 98-05, WHY EURO 2 50 2T 03-05, ZUMA 50 2T 97-01



cod. 9911250

Set 3 serie molle per frizione a 3 ceppi con campana Ø interno 105 mm e 107 mm (cod. 9911060 cod. 9910020)

Codice	Colore	Carico kg
9908440	GIALLO	6,3
9911250	VERDE	9
9908450	VIOLA	13

APPLICABILITÀ

APRILIA AMICO 50 2T 94-94, AMICO 50 2T 96-98, AMICO GL/GLE 50 2T 93-95, AMICO LX/SPORT/CAT 50 2T 92-93, AREA 51 50 2T 98-00, GULLIVER 50 2T 95-98, GULLIVER LC 50 2T 96-98, MOJITO CUSTOM 2T MOTORE PIAGGIO 50 2T 04-10, RALLY 50 2T 95-03, RALLY LIQUID COOLED 50 2T 96-99, SCARABEO 50 2T 93-05, SCARABEO 2T EU2 MOTORE PIAGGIO 50 2T 10-12, SCARABEO 2T NET 50 2T 09-10, SCARABEO 4T 50 4T 02-06, SCARABEO 4T 4V 50 4T-4V 10-12, SCARABEO 4T 4V NET 50 4T-4V 09-10, SCARABEO 4T RESTYLING EU3 50 4T 06-09, SCARABEO QUATTRO 50 4T-4V 09-09, SCARABEO STREET 50 2T 05-06, SCARABEO STREET 2T RESTYLING 50 2T 06-09, SONIC 50 2T 98-07, SONIC GP 50 2T 98-08, SPORT CITY ONE 2T 50 2T 08-11, SPORT CITY ONE 4T 50 4T 08-10, SR (ORIZZONTALE) 50 2T 94-96, SR (VERTICALE) 50 2T 93-93, SR LIQUID COOLED 50 2T 94-96, SR MOTARD 50 2T 12-14, SR R 50 2T 04-09, SR R FACTORY CARBURATORE 50 2T 10-14, SR R FACTORY IE 50 2T 10-14, SR RACING 50 2T 97-99, SR STEALTH 50 2T 97-00, SR STREET CARBURATORE 50 2T 03-12, SR WWW 50 2T 97-01

ATALA CAROSELLO 50 2T 99-01

BENELLI 491 GT 50 2T 98-99, 491 NAKED 50 2T 02-02, 491 RACING 50 2T 98-99, 491 RR 50 2T 99-01, 491 SP 50 2T 99-99, 491 SPORT 50 2T 98-99, 491 ST 50 2T 99-01, K2 50 2T 98-01, K2 LIQUID COOLED 50 2T 98-01, PEPE 50 2T 99-01, PEPE 50 2T 10-10, PEPE LX 50 2T 03-04

BETA ARK 50 2T 96-08, ARK LC 50 2T 96-08, CHRONO 50 2T 95-96, EIKON 50 2T 99-03, QUADRA 50 2T 95-95, QUADRA 50 2T 99-01, TEMPO 50 2T 93-02, TEMPO 50 2T 95-95

BSV DIO GP 50 2T 94-96, DIO SP 50 2T 94-96, DIO ZX 50 2T 94-96

DERBI ATLANTIS 2 50 2T 10-10, ATLANTIS 2T EU2 50 2T 07-09, ATLANTIS 02 50 2T 02-02, ATLANTIS 02 BULLET 50 2T 03-05, ATLANTIS 02 CITY 50 2T 04-06, ATLANTIS 02 RED BULLET 50 2T 03-03, ATLANTIS 02 TWO CHIC 50 2T 05-05, BOULEVARD 2 50 2T 09-14, GP1 50 2T 01-03, GP1 EU 2 50 2T 05-05, GP1 OPEN EU2 50 2T 06-09, GP1 RACE EU2 50 2T 05-07, SONAR 2 50 2T 09-09

GILERA DNA 50 2T 00-02, DNA 50 2T 05-07, DNA GP EXPERIENCE 50 2T 03-04, EASY MOVING 50 2T 95-96, ICE 50 2T 01-05, RUNNER 50 2T 97-00, RUNNER POGGIALI 50 2T 02-02, RUNNER SP 50 2T 02-07, RUNNER SP 50 2T 10-12, RUNNER SP SPECIAL EDITION 50 2T 07-07, RUNNER SP ST & SIMONCELLI 50 2T 08-09, STALKER 50 2T 97-11, STALKER NAKED 50 2T 08-08, STALKER SPECIAL EDITION 50 2T 07-08, STORM 50 2T 94-95, STORM EURO 2 50 2T 07-07, TYPHOON 50 2T 94-97, TYPHOON X 50 2T 98-99

HONDA BALI 50 2T 93-99, DIO ZX 50 2T 94-96, SFX / SXR 50 2T 95-01, SGX SKY 50 2T 97-04, SH NEW 50 2T 96-01

HSC SC 01 50 2T 94-96, SC 01 L 50 2T 94-96

ITALJET BAZOOKA 50 2T 91-94, DRAGSTER 50 2T 98-02, JET SET 50 2T 02-02, PISTA 50 2T 92-97, PISTA 2 50 2T 97-98, SCOOP 50 2T 91-95, SCOOP 2 50 2T 96-98, TORPEDO NEW 50 2T 00-01, YANKEE 50 2T 93-97

KTM K50 50 2T 96-01

KYMCO AGILITY R12 50 4T 05-05

MACAL THUNDER 50 2T 95-96

MALAGUTI CENTRO SL 50 2T 94-98, CIAK 50 2T 99-01, CIAK EURO 2,2,3 50 2T 03-03, CIAK EURO2 50 2T 01-03, F10 50 2T 92-00, F10 EURO 2 50 2T 02-06, F10 EURO 2,2,3 50 2T 03-04, F12 PHANTOM 50 2T 94-98, F12 PHANTOM EURO 2 50 2T 02-02, F12 PHANTOM EURO 2,2,3 50 2T 03-04, F12 PHANTOM LC EURO 2 50 2T 99-02, F12 RESTYLING EURO 2 50 2T 06-06, F15 FIRE FOX 50 2T 96-98, F15 FIRE FOX EURO 2 50 2T 02-03, F15 FIRE FOX EURO 2,2,3 50 2T 03-04, YESTERDAY 50 2T 97-00

MBK BOOSTER 50 2T 90-04, BOOSTER 50 2T 90-94, BOOSTER EURO 2 50 2T 04-04, BOOSTER NG 50 2T 95-03, BOOSTER ROCKET 50 2T 97-98, BOOSTER SPIRIT 50 2T 96-00, BOOSTER SPIRIT 50 2T 03-03, BOOSTER SPIRIT EURO2 50 2T 03-03, BOOSTER TRACK 50 2T 96-98, FLIPPER 50 2T 98-04, FLIPPER EURO 2 50 2T 03-03, MACH G 50 2T 02-04, MACH G LC 50 2T 02-04, NITRO 50 2T 97-04, NITRO EURO 2 50 2T 03-03, OVETTO 50 2T 97-04, OVETTO EURO 2 50 2T 02-02, SORRISO 50 2T 95-96, STUNT 50 2T 00-02, TARGET 50 2T 91-95

MOTRON SYNCRO 50 2T 98-00, THUNDER 50 2T 95-98

PEUGEOT BUXY 50 2T 90-02, BUXY RS 50 2T 90-02, ELYSEO 50 2T 90-02, JET FORCE 50 2T 90-02, LOOXOR 50 2T 90-02, METAL X 50 2T 90-02, SPEEDAKE 50 2T 90-02, SPEEDFIGHT 50 2T 97-04, SPEEDFIGHT LC 50 2T 97-04, SQUAB 50 2T 90-02, SV GEO 50 2T 90-02, TRESSER 50 2T 90-02, VIVACITY 50 2T 90-02, X-FIGHT 50 2T 00-02, X-FIGHT LC 50 2T 00-02, ZENITH 50 2T 90-02

PIAGGIO DIESIS 50 2T 01-01, FLY 2T 50 2T 05-07, FLY 2T 50 2T 10-11, FLY 4T 50 4T 05-07, FLY 4T & 25-30 KM/H 50 4T 08-11, FLY 4T MOTORE CHN 50 4T 06-07, FREE 50 2T 92-94, FREE DELIVERY 50 2T 00-01, LIBERTY 50 2T 97-05, LIBERTY 2T 50 2T 06-08, LIBERTY 2T PTT EU2 50 2T 04-05, LIBERTY 2T RST 50 2T 04-04, LIBERTY 2T SPORT 50 2T 06-08, LIBERTY 4T 50 4T 00-02, LIBERTY 4T 50 4T 05-08, LIBERTY 4T 3V IE 50 4T-3V 15-17, LIBERTY 4T 3V IE E4 50 4T-3V 17-18, LIBERTY 4T DELIVERY - SINGLE 50 4T 10-14, LIBERTY 4T DELIVERY TNT 50 4T 09-09, LIBERTY 4T PTT - DOUBLE - NEXIVE 50 4T 09-17, LIBERTY 4T RST 50 4T 04-04, LIBERTY 4T SPORT 50 4T 06-08, LIBERTY MOC 2T & ELLE 50 2T 09-13, LIBERTY MOC 4T & ELLE 50 4T 09-16, NRG 50 2T 94-96, NRG POWER DT 50 2T 06-15, NRG POWER DT SERIE SPECIALE 50 2T 07-08, NRG RST MC2 50 2T 96-98, NTT 50 2T 95-96, QUARTZ 50 2T 92-96, SFERA 50 2T 91-93, SFERA MAQUILLAGE 2 50 2T 94-94, SFERA RST 50 2T 95-97, TYPHOON 2T E2 50 2T 10-12, TYPHOON 2T E3 CH 50 2T 11-11, VESPA ET2 50 2T 97-05, VESPA ET4 50 4T 00-05, ZIP 50 2T 92-93, ZIP 50 2T 95-96, ZIP 4T 50 4T 00-13, ZIP BIMODALE 50 2T 94-97, ZIP FAST RIDER 50 2T 93-94, ZIP FAST RIDER RST 50 2T 96-97, ZIP RST 50 2T 96-99, ZIP SP 50 2T 96-00

RIEJU FIRST 50 2T 95-98, WINDY 50 2T 95-98

YAMAHA AEROX 50 2T 97-02, AEROX 50 2T 04-16, AEROX EURO 2 50 2T 03-03, AEROX NAKED 50 2T 13-16, AEROX R 50 2T 99-00, BW'S 50 2T 97-16, BW'S BUMP 50 2T 97-98, BW'S EASY 50 2T 13-13, BW'S NAKED 50 2T 03-04, BW'S NAKED 50 2T 09-16, BW'S NEXT GENERATION 50 2T 97-06, BW'S ORIGINAL 50 2T 99-01, BW'S ORIGINAL EURO 2 50 2T 03-03, CRZ 50 2T 91-95, CT 50 2T 90-95, JOG R 50 2T 02-02, JOG R EURO2 50 2T 02-02, JOG R EURO2 50 2T 06-15, JOG R LC 50 2T 02-15, NEO'S 50 2T 97-02, NEO'S 50 2T 04-16, NEO'S EASY 50 2T 13-13, NEO'S EURO 2 50 2T 02-02, RS SPY 50 2T 95-98, SLIDER 50 2T 00-02, WHY 50 2T 98-05, WHY EURO 2 50 2T 03-05, ZUMA 50 2T 97-01



cod. 9912740

Set 3 serie molle per frizione originale a 3 ceppi con campana Ø interno 107 mm

Codice	Colore	Carico kg
9912690	VERDE	8
9912700	VIOLA	10
9912710	ROSA	12

APPLICABILITÀ

APRILIA AREA 51 50 2T 98-00, GULLIVER 50 2T 95-98, GULLIVER LC 50 2T 96-98, RALLY 50 2T 95-03, RALLY LIQUID COOLED 50 2T 96-99, SCARABEO 50 2T 93-05, SONIC 50 2T 98-07, SONIC GP 50 2T 98-08, SR LIQUID COOLED 50 2T 94-96, SR RACING 50 2T 97-99, SR STEALTH 50 2T 97-00

BENELLI 491 GT 50 2T 98-99, 491 NAKED 50 2T 02-02, 491 RACING 50 2T 98-99, 491 RR 50 2T 99-01, 491 SP 50 2T 99-99, 491 SPORT 50 2T 98-99, 491 ST 50 2T 99-01, K2 50 2T 98-01, K2 LIQUID COOLED 50 2T 98-01, PEPE 50 2T 99-01, PEPE 50 2T 10-10, PEPE LX 50 2T 03-04

BETA ARK 50 2T 96-08, ARK LC 50 2T 96-08, CHRONO 50 2T 95-96, EIKON 50 2T 99-03, QUADRA 50 2T 95-95, QUADRA 50 2T 99-01, TEMPO 50 2T 93-02, TEMPO 50 2T 95-95

GARELLI GPS 50 2T 09-11

ITALJET DRAGSTER 50 2T 98-02

KYMCO AGILITY 4T R10 50 4T 06-08, AGILITY 4T R12 50 4T 07-08, AGILITY R12 50 4T 05-05, AGILITY R16 50 4T 08-09, AGILITY R16 50 4T 12-12, AGILITY R16 2T 50 2T 10-10, AGILITY R16 2T 50 2T 12-12, AGILITY RS 50 4T 09-09, AGILITY RS NAKED 50 2T 10-10, B&W 50 2T 02-02, B&W EU2 50 2T 03-03, CX 50 2T 93-93, CX SUPER 50 2T 94-97, DINK 50 4T 50 4T 07-07, DINK CLASSIC EU2 50 2T 03-03, DJ WORLD 50 2T 94-00, DJ X 50 2T 91-92, DJ Y 50 2T 93-93, FEVER ZX 50 2T 99-00, FEVER ZX EU2 50 2T 03-04, FILLY 50 4T 98-00, FILLY LX 50 4T 01-02, HEROISM 50 2T 95-97, K 12 50 2T 95-00, KB 50 2T 95-00, PEOPLE 50 2T 99-04, PEOPLE EURO 2 50 2T 03-03, PEOPLE EURO 2 50 2T 08-08, PEOPLE S 50 2T 05-08, PEOPLE S 4T 50 4T 06-08, SENTO 50 4T 08-08, SNIPER 50 2T 93-93, SNIPER DD 50 2T 94-96, SUPER 9 50 2T 00-00, SUPER 9 EU2 50 2T 03-04, VITALITY 2T 50 2T 04-04, VITALITY 4T 50 4T 04-04, YUP 50 2T 02-02, YUP EU2 50 2T 03-03

MALAGUTI CIAK 50 2T 99-01, CIAK EURO 2 2,3 50 2T 03-03, CIAK EURO2 50 2T 01-03, CIAK MASTER EURO 2 50 2T 06-06, F10 EURO 2 50 2T 02-06, F10 EURO 2 2,3 50 2T 03-04, F10 RESTYLING EURO 2 50 2T 06-06, F12 PHANTOM 50 2T 94-98, F12 PHANTOM EURO 2 50 2T 02-02, F12 PHANTOM EURO 2 2,3 50 2T 03-04, F12 PHANTOM LC EURO 2 2,3 50 2T 03-04, F12 R PHANTOM LC 50 2T 07-10, F12 RESTYLING EURO 1 50 2T 99-02, F12 RESTYLING EURO 2 50 2T 06-06, F12 RESTYLING LC EURO 2 50 2T 06-06, F15 FIRE FOX 50 2T 96-98, F15 FIRE FOX AIR COOLED 50 2T 05-06, F15 FIRE FOX EURO 2 50 2T 02-06, F15 FIRE FOX EURO 2 2,3 50 2T 03-04, YESTERDAY 50 2T 97-00

MBK BOOSTER 50 2T 90-04, BOOSTER 50 2T 90-94, BOOSTER EURO 2 50 2T 04-04, BOOSTER NG 50 2T 95-03, BOOSTER SPIRIT 50 2T 96-00, BOOSTER SPIRIT 50 2T 03-03, BOOSTER SPIRIT EURO2 50 2T 03-03, BOOSTER X IE 50 4T-3V 08-08, FLIPPER 50 2T 98-04, FLIPPER EURO 2 50 2T 03-03, MACH G 50 2T 02-04, MACH G LC 50 2T 02-04, NITRO 50 2T 97-04, NITRO EURO 2 50 2T 03-03, OVETTO 50 2T 97-04, OVETTO 4T 50 4T-3V 09-11, OVETTO EURO 2 50 2T 02-02, STUNT 50 2T 00-02

YAMAHA AEROX 50 2T 97-02, AEROX 50 2T 04-16, AEROX EURO 2 50 2T 03-03, AEROX NAKED 50 2T 13-16, AEROX R 50 2T 99-00, BW'S 50 2T 97-16, BW'S BUMP 50 2T 97-98, BW'S EASY 50 2T 13-13, BW'S NAKED 50 2T 03-04, BW'S NAKED 50 2T 09-16, BW'S NEXT GENERATION 50 2T 97-06, BW'S ORIGINAL 50 2T 99-01, BW'S ORIGINAL EURO 2 50 2T 03-03, GIGGLE 50 4T-3V 08-08, JOG R 50 2T 02-02, JOG R EURO2 50 2T 02-02, JOG R EURO2 50 2T 06-15, JOG R LC 50 2T 02-15, NEO'S 50 2T 97-02, NEO'S 50 2T 04-16, NEO'S 4 50 4T-3V 09-15, NEO'S EASY 50 2T 13-13, NEO'S EURO 2 50 2T 02-02, SLIDER 50 2T 00-02, WHY 50 2T 98-05, WHY EURO 2 50 2T 03-05, ZEST 50 2T 95-92, ZUMA 50 2T 97-01

PIGNONI/INGRANAGGI



◀ Pignoni catena per motori Minarelli AM6

		Z12	Z14
1/2" x 3/16" x 7,75	per catena 415	9918470	9917930
1/2" x 1/4" x 7,75	per catena 420	9918490	9917980
1/2" x 5/16" x 8,51	per catena 428		

◀ cod. 9919080

RACING

Ingranaggio 6 velocità Ø18 su albero primario Z=26 per motori Minarelli AM6 1° SERIE

APPLICABILITÀ

APRILIA CLASSIC 50 2T 92-99, MX 50 2T 04-04, MX MOTARD 50 2T 95-03, RS 50 2T 93-05, RX 50 2T 03-04, RX ENDURO 50 2T 95-03, TUONO 50 2T 03-04

BETA RR 2T 50 EU4 50 2T 18-20, RR 50 RACING EU4 50 2T 18-20, RR ALU 50 2T 08-12, RR ENDURO 50 2T 06-17, RR MOTARD 50 2T 06-17

CH HUSQUARNA SM 50 2T 00-10, WR 50 2T 00-10, WSM 50 2T 00-10

CMC ENDURO 50 2T 11-11, MOTARD 50 2T 11-11

FANTIC CABALLERO MOTARD 50 2T 06-10, CABALLERO REGOLARITÀ 50 2T 06-10, ENDURO COMPETITION EU4 50 2T 18-20, ENDURO PERFORMANCE EU4 50 2T 18-20, MOTARD COMPETITION EU4 50 2T 18-20, MOTARD PERFORMANCE EU4 50 2T 18-20

HM BAJA, DERAPAGE BASIC 50 2T 10-11, CMC 50 2T 10-11, CRE BAJA RR, DERAPAGE RR 50 2T 07-11, CRE BAJA, DERAPAGE 50 2T 07-11, CRE SIX COMPETITION 50 2T 10-11, CRE SIX, BAJA, DERAPAGE 50 2T 95-06, CRE SIX, DERAPAGE COMPETITION 50 2T 07-09, DERAPAGE COMPETITION 50 2T 10-11

MALAGUTI CNK DRAGON 50 2T 05-07, XSM 50 2T 03-03, XTM 50 2T 03-03

MBK X LIMIT 50 2T 03-04, X POWER 50 2T 03-04

MINARELLI MOTORE AM 6 1° SERIE 50 2T 96-11

MOTORHISPANIA PEUGEOT FURIA 50 2T 97-00, FURIA MAX 50 2T 10-12, RX 50 2T 09-12, RX R 50 2T 09-12

PEUGEOT SUPERMOTARD 50 2T 90-02, XP6 TRAIL S/AVV. ELETTRICO 50 2T 90-02, XR6 RACING CAT. C/AVV.ELETT. 50 2T 90-02

RIEJU MRT 50 2T 09-12, MRT 50 EU4 50 2T 18-20, MRT PRO 50 2T 09-12, MRT PRO EU4 50 2T 18-20, MRT PRO REPLICCA EU4 50 2T 18-20, MRT PRO REPLICCA SM EU4 50 2T 18-20, MRT PRO SM 50 2T 09-12, MRT PRO SM EU4 50 2T 18-20, MRT SM 50 2T 09-12, MRT SM EU4 50 2T 18-20, MRT TROPHY EU4 50 2T 18-20, MRX 50 2T 01-04, MRX PRO 50 2T 01-04, RR 50 2T 05-06, RS1 50 2T 98-01, RS2 MATRIX 50 2T 05-06, RS2 MATRIX PRO 50 2T 05-06, RS2 NAKED 50 2T 04-05, RS3 EU4 50 2T 18-20, RS3 NKD EU4 50 2T 18-20, SMX E.S./K.S. 50 2T 01-01, SMX PRO E.S./K.S. 50 2T 03-03, SPIKE 50 2T 98-01

SHERCO FACTORY SE-R EU4 50 2T 18-20, FACTORY SE-RS EU4 50 2T 18-20, FACTORY SILVER SM-R EU4 50 2T 18-20, FACTORY SILVER SM-RS EU4 50 2T 18-20, FACTORY SM-R EU4 50 2T 18-20, FACTORY SM-RS EU4 50 2T 18-20, HRD ENDURO 50 2T 09-13, HRD MOTARD 50 2T 09-13

YAMAHA DT R 50 2T 03-11, DT RSM 50 2T 03-05, DT X 50 2T 06-11, TZR 50 2T 03-08, TZR 50 2T 10-10, TZR RR 50 2T 05-05



◀ cod. **9931910**

Ingranaggio 6° velocità Ø20 su albero primario Z=26 per motori Minarelli AM6 2° serie

APPLICABILITÀ

APRILIA	CLASSIC 50 2T 92-99, MX 50 2T 04-04, MX MOTARD 50 2T 95-03, RS 50 2T 93-05, RX 50 2T 03-04, RX ENDURO 50 2T 95-03, TUONO 50 2T 03-04	MOTORHISPANIA	FURIA 50 2T 97-00, FURIA MAX 50 2T 10-12, RX 50 2T 09-12, RX R 50 2T 09-12
BETA	RR 2T 50 EU4 50 2T 18-20, RR 50 RACING EU4 50 2T 18-20, RR ALU 50 2T 08-12, RR ENDURO 50 2T 06-17, RR MOTARD 50 2T 06-17	PEUGEOT	SUPERMOTARD 50 2T 90-02, XP6 TRAIL S/AVV. ELETTRICO 50 2T 90-02, XR6 RACING CAT. C/AVV.ELETT. 50 2T 90-02
CH HUSQUARNA	SM 50 2T 00-10, WR 50 2T 00-10, WSM 50 2T 00-10	RIEJU	MRT 50 2T 09-12, MRT 50 EU4 50 2T 18-20, MRT PRO 50 2T 09-12, MRT PRO EU4 50 2T 18-20, MRT PRO REPLICCA EU4 50 2T 18-20, MRT PRO REPLICCA SM EU4 50 2T 18-20, MRT PRO SM 50 2T 09-12, MRT PRO SM EU4 50 2T 18-20, MRT SM 50 2T 09-12, MRT SM EU4 50 2T 18-20, MRT TROPHY EU4 50 2T 18-20, MRX 50 2T 01-04, MRX PRO 50 2T 01-04, RR 50 2T 05-06, RS1 50 2T 98-01, RS2 MATRIX 50 2T 05-06, RS2 MATRIX PRO 50 2T 05-06, RS2 NAKED 50 2T 04-05, RS3 EU4 50 2T 18-20, RS3 NKD EU4 50 2T 18-20, SMX E.S./K.S. 50 2T 01-01, SMX PRO E.S./K.S. 50 2T 03-03, SPIKE 50 2T 98-01
CMC	ENDURO 50 2T 11-11, MOTARD 50 2T 11-11	SHERCO	FACTORY SE-R EU4 50 2T 18-20, FACTORY SE-RS EU4 50 2T 18-20, FACTORY SILVER SM-R EU4 50 2T 18-20, FACTORY SILVER SM-RS EU4 50 2T 18-20, FACTORY SM-R EU4 50 2T 18-20, FACTORY SM-RS EU4 50 2T 18-20, HRD ENDURO 50 2T 09-13, HRD MOTARD 50 2T 09-13
FANTIC	CABALLERO MOTARD 50 2T 06-10, CABALLERO REGOLARITÀ 50 2T 06-10, ENDURO COMPETITION EU4 50 2T 18-20, ENDURO PERFORMANCE EU4 50 2T 18-20, MOTARD COMPETITION EU4 50 2T 18-20, MOTARD PERFORMANCE EU4 50 2T 18-20	VENT	BAJA 50 2T 18-20, BAJA RR 50 2T 18-20, DERAPAGE 50 2T 18-20, DERAPAGE RR 50 2T 18-20
HM	BAJA, DERAPAGE BASIC 50 2T 10-11, CMC 50 2T 10-11, CRE BAJA RR, DERAPAGE RR 50 2T 07-11, CRE BAJA, DERAPAGE 50 2T 07-11, CRE SIX COMPETITION 50 2T 10-11, CRE SIX, BAJA, DERAPAGE 50 2T 95-06, CRE SIX, DERAPAGE COMPETITION 50 2T 07-09, DERAPAGE COMPETITION 50 2T 10-11	YAMAHA	DT R 50 2T 03-11, DT RSM 50 2T 03-05, DT X 50 2T 06-11, TZR 50 2T 03-08, TZR 50 2T 10-10, TZR RR 50 2T 05-05
MALAGUTI	CNK DRAGON 50 2T 05-07, XSM 50 2T 03-03, XTM 50 2T 03-03		
MBK	X LIMIT 50 2T 03-04, X POWER 50 2T 03-04		
MINARELLI	MOTORE AM 6 2° SERIE 50 2T 12-18		

RASAMENTI

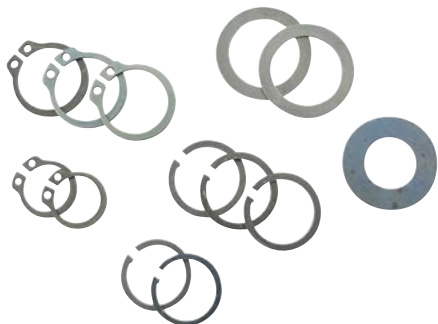

◀ cod. **9935030**

Kit Rasamenti e seeger cambio AM6 1° serie e racing

A RICAMBIO PER

9935000	CAMBIO COMPLETO RACING AM6
---------	----------------------------

NOVITÀ

APPLICABILITÀ

APRILIA	CLASSIC 50 2T 92-99, MX 50 2T 04-04, MX MOTARD 50 2T 95-03, RS 50 2T 96-05, RX 50 2T 03-04, RX ENDURO 50 2T 95-03, RX RACING 50 2T 03-06, TUONO 50 2T 03-04	HM	BAJA, DERAPAGE BASIC 50 2T 10-11, CMC 50 2T 10-11, CRE BAJA RR, DERAPAGE RR 50 2T 07-11, CRE BAJA, DERAPAGE 50 2T 07-11, CRE SIX COMPETITION 50 2T 10-11, CRE SIX, BAJA, DERAPAGE 50 2T 95-06, CRE SIX, DERAPAGE COMPETITION 50 2T 07-09, DERAPAGE COMPETITION 50 2T 10-11	MOTORHISPANIA	FURIA 50 2T 97-00, FURIA MAX 50 2T 10-12, RX 50 2T 09-12, RX R 50 2T 09-12
BETA	RR ALU 50 2T 08-12	MALAGUTI	CNK DRAGON 50 2T 05-07, XSM 50 2T 03-06, XSM POWER-UP 50 2T 07-10, XTM 50 2T 03-03, XTM 50 2T 06-06, XTM POWER-UP 50 2T 07-10	PEUGEOT	SUPERMOTARD 50 2T 90-02, XP6 TRAILS/AVV. ELETTRICO 50 2T 90-02, XR6 RACING CAT. C/AVV.ELETT. 50 2T 90-02
CH HUSQUARNA	SM 50 2T 00-10, WR 50 2T 00-10, WSM 50 2T 00-10	MBK	X LIMIT 50 2T 03-04, X POWER 50 2T 03-04	RIEJU	MRT 50 2T 09-12, MRT PRO 50 2T 09-12, MRT PRO SM 50 2T 09-12, MRT SM 50 2T 09-12, MRX 50 2T 01-04, MRX PRO 50 2T 01-04, RR 50 2T 05-06, RS1 50 2T 98-01, RS2 MATRIX 50 2T 05-06, RS2 MATRIX PRO 50 2T 05-06, RS2 NAKED 50 2T 04-05, SMX E.S./K.S. 50 2T 01-01, SMX PRO E.S./K.S. 50 2T 03-03, SPIKE 50 2T 98-01
CMC	ENDURO 50 2T 11-11, MOTARD 50 2T 11-11	MINARELLI	MOTORE AM 6 1° SERIE 50 2T 96-11	YAMAHA	DT R 50 2T 03-11, DT RSM 50 2T 03-05, DT X 50 2T 06-11, TZR 50 2T 03-08, TZR 50 2T 10-11, TZR RR 50 2T 05-05
FANTIC	CABALLERO MOTARD 50 2T 06-10, CABALLERO MOTARD COMPETITION 50 2T 06-10, CABALLERO REGOLARITÀ 50 2T 06-10, CABALLERO REGOLARITÀ COMPETITION 50 2T 06-10				



◀ **cod. 9913300**
Rapporti primari allungati
Z= 15/50 Rapporto 1:3,33

APPLICABILITÀ

APRILIA AMICO 50 2T 94-94, AMICO 50 2T 96-98, AMICO GL/GLE 50 2T 93-95, AMICO LX/SPORT/CAT 50 2T 92-93, AREA 51 50 2T 98-00, GULLIVER 50 2T 95-98, GULLIVER LC 50 2T 96-98, RALLY 50 2T 95-03, RALLY LIQUID COOLED 50 2T 96-99, SCARABEO 50 2T 93-05, SR (ORIZZONTALE) 50 2T 94-96, SR (VERTICALE) 50 2T 93-93, SR LIQUID COOLED 50 2T 94-96, SR RACING 50 2T 97-99, SR STEALTH 50 2T 97-00, SR WWW 50 2T 97-01

ATALA CAROSELLO 50 2T 99-01

BENELLI 491 GT 50 2T 98-99, 491 NAKED 50 2T 02-02, 491 RACING 50 2T 98-99, 491 RR 50 2T 99-01, 491 SP 50 2T 99-99, 491 SPORT 50 2T 98-99, 491 ST 50 2T 99-01, K2 50 2T 98-01, K2 LIQUID COOLED 50 2T 98-01, PEPE 50 2T 99-01, PEPE LX 50 2T 03-04

BETA ARK 50 2T 96-08, ARK LC 50 2T 96-08, CHRONO 50 2T 95-96, EIKON 50 2T 99-03, QUADRA 50 2T 95-95, QUADRA 50 2T 99-01, TEMPO 50 2T 93-02, TEMPO 50 2T 95-95

ITALJET DRAGSTER 50 2T 98-02

KTM K50 50 2T 96-01

MACAL THUNDER 50 2T 95-96

MALAGUTI CENTRO SL 50 2T 94-98, CIAK 50 2T 99-01, CIAK EURO 2 2,3 50 2T 03-03, CIAK EURO2 50 2T 01-03, CIAK MASTER EURO 2 50 2T 06-06, F12 PHANTOM 50 2T 94-98, F12 PHANTOM EURO 2 2,3 50 2T 03-04, F12 PHANTOM LC 50 2T 94-98, F12 R PHANTOM LC 50 2T 07-10, F12 RESTYLING EURO 2 50 2T 06-06, F15 FIRE FOX 50 2T 96-98, F15 FIRE FOX AIR COOLED 50 2T 05-06, F15 FIRE FOX EURO 2 50 2T 02-06, F15 FIRE FOX EURO 2,3 50 2T 03-04

MBK BOOSTER 50 2T 90-04, BOOSTER 50 2T 90-94, BOOSTER EURO 2 50 2T 04-04, BOOSTER NG 50 2T 95-03, BOOSTER ROCKET 50 2T 97-98, BOOSTER SPIRIT 50 2T 96-00, BOOSTER SPIRIT 50 2T 03-03, BOOSTER SPIRIT EURO2 50 2T 03-03, BOOSTER TRACK 50 2T 96-98, FLIPPER 50 2T 98-04, FLIPPER EURO 2 50 2T 03-03, MACH G 50 2T 02-04, MACH G LC 50 2T 02-04, NITRO 50 2T 97-04, NITRO EURO 2 50 2T 03-03, OVETTO 50 2T 97-04, OVETTO EURO 2 50 2T 02-02, STUNT 50 2T 00-02

MOTRON SYNCRO 50 2T 98-00, THUNDER 50 2T 95-98

RIEJU FIRST 50 2T 95-98, WINDY 50 2T 95-98

YAMAHA AEROX 50 2T 97-02, AEROX 50 2T 04-16, AEROX EURO 2 50 2T 03-03, AEROX NAKED 50 2T 13-16, AEROX R 50 2T 99-00, BW'S 50 2T 97-16, BW'S BUMP 50 2T 97-98, BW'S EASY 50 2T 13-13, BW'S NAKED 50 2T 03-04, BW'S NAKED 50 2T 09-16, BW'S NEXT GENERATION 50 2T 97-06, BW'S ORIGINAL 50 2T 99-01, BW'S ORIGINAL EURO 2 50 2T 03-03, JOG R 50 2T 02-02, JOG R EURO2 50 2T 02-02, JOG R EURO2 50 2T 06-15, JOG R LC 50 2T 02-15, NEO'S EURO 2 50 2T 97-02, NEO'S 50 2T 04-16, NEO'S EASY 50 2T 13-13, NEO'S EURO 2 50 2T 02-02, RS SPY 50 2T 95-98, SLIDER 50 2T 00-02, WHY 50 2T 98-05, WHY EURO 2 50 2T 03-05, ZUMA 50 2T 97-01



◀ **cod. 9909520**
Rapporti secondari allungati
Z= 15/41 Rapporto 1:2,73

APPLICABILITÀ

APRILIA AREA 51 50 2T 98-00, GULLIVER LC 50 2T 96-98, RALLY LIQUID COOLED 50 2T 96-99, SR (ORIZZONTALE) 50 2T 94-96, SR LIQUID COOLED 50 2T 94-96, SR RACING 50 2T 97-99, SR STEALTH 50 2T 97-00

BENELLI 491 GT 50 2T 98-99, 491 RACING 50 2T 98-99, 491 RR 50 2T 99-01, 491 SP 50 2T 99-99, 491 SPORT 50 2T 98-99, 491 ST 50 2T 99-01, PEPE 50 2T 99-01, PEPE LX 50 2T 03-04

BETA ARK LC 50 2T 96-08, EIKON 50 2T 99-03

ITALJET DRAGSTER 50 2T 98-02

MALAGUTI F12 PHANTOM 50 2T 94-98, F12 PHANTOM EURO 2 2,3 50 2T 03-04, F12 PHANTOM LC 50 2T 94-98, F12 R PHANTOM LC 50 2T 07-10, F12 RESTYLING EURO 2 50 2T 06-06, F15 FIRE FOX 50 2T 96-98, F15 FIRE FOX AIR COOLED 50 2T 05-06, F15 FIRE FOX EURO 2 50 2T 02-06, F15 FIRE FOX EURO 2,3 50 2T 03-04

MBK BOOSTER NG 50 2T 95-03, MACH G LC 50 2T 02-04, NITRO 50 2T 97-04, NITRO EURO 2 50 2T 03-03, STUNT 50 2T 00-02

YAMAHA AEROX 50 2T 97-02, AEROX 50 2T 04-16, AEROX EURO 2 50 2T 03-03, AEROX NAKED 50 2T 13-16, AEROX R 50 2T 99-00, BW'S NEXT GENERATION 50 2T 97-03, JOG R LC 50 2T 02-15, RS SPY 50 2T 95-98, SLIDER 50 2T 00-02, WHY 50 2T 98-05, WHY EURO 2 50 2T 03-05

APPLICABILITÀ

APRILIA AREA 51 50 2T 98-00, GULLIVER 50 2T 95-98, GULLIVER LC 50 2T 96-98, RALLY 50 2T 95-03, RALLY LIQUID COOLED 50 2T 96-99, SR (ORIZZONTALE) 50 2T 94-96, SR (VERTICALE) 50 2T 93-93, SR LIQUID COOLED 50 2T 94-96, SR RACING 50 2T 97-99, SR STEALTH 50 2T 97-00, SR WWW 50 2T 97-01

ATALA CAROSELLO 50 2T 99-01

BENELLI 491 GT 50 2T 98-99, 491 NAKED 50 2T 02-02, 491 RACING 50 2T 98-99, 491 RR 50 2T 99-01, 491 SP 50 2T 99-99, 491 SPORT 50 2T 98-99, 491 ST 50 2T 99-01, K2 50 2T 98-01, K2 LIQUID COOLED 50 2T 98-01, PEPE 50 2T 99-01, PEPE LX 50 2T 03-04

BETA ARK 50 2T 96-08, ARK LC 50 2T 96-08, CHRONO 50 2T 95-96, EIKON 50 2T 99-03, QUADRA 50 2T 95-95, QUADRA 50 2T 99-01, TEMPO 50 2T 93-02, TEMPO 50 2T 95-95

ITALJET DRAGSTER 50 2T 98-02

KTM K50 50 2T 96-01

MACAL THUNDER 50 2T 95-96

MALAGUTI CENTRO SL 50 2T 94-98, F12 PHANTOM 50 2T 94-98, F12 PHANTOM EURO 2 50 2T 02-02, F12 PHANTOM EURO 2 2,3 50 2T 03-04, F12 PHANTOM LC 50 2T 94-98, F12 R PHANTOM LC 50 2T 07-10, F12 RESTYLING EURO 1 50 2T 99-02, F12 RESTYLING EURO 2 50 2T 06-06, F12 RESTYLING LC EURO 2 50 2T 06-06, F15 FIRE FOX 50 2T 96-98, F15 FIRE FOX AIR COOLED 50 2T 05-06, F15 FIRE FOX EURO 2 50 2T 02-06, F15 FIRE FOX EURO 2,3 50 2T 03-04

MBK BOOSTER 50 2T 90-04, BOOSTER 50 2T 90-94, BOOSTER EURO 2 50 2T 04-04, BOOSTER NG 50 2T 95-03, BOOSTER ROCKET 50 2T 97-98, BOOSTER SPIRIT 50 2T 96-00, BOOSTER SPIRIT 50 2T 03-03, BOOSTER SPIRIT EURO2 50 2T 03-03, BOOSTER TRACK 50 2T 96-98, MACH G 50 2T 02-04, MACH G LC 50 2T 02-04, NITRO 50 2T 97-04, NITRO EURO 2 50 2T 03-03, OVETTO 50 2T 97-04, OVETTO EURO 2 50 2T 02-02, STUNT 50 2T 00-02

◀ **cod. 990875P**
Rapporti secondari allungati
Z= 16/41 Rapporto 1:2,56

RACING

MOTRON SYNCRO 50 2T 98-00, THUNDER 50 2T 95-98

RIEJU FIRST 50 2T 95-98, WINDY 50 2T 95-98

YAMAHA AEROX 50 2T 97-02, AEROX 50 2T 04-16, AEROX EURO 2 50 2T 03-03, AEROX NAKED 50 2T 13-16, AEROX R 50 2T 99-00, BW'S 50 2T 97-16, BW'S BUMP 50 2T 97-98, BW'S EASY 50 2T 13-13, BW'S NAKED 50 2T 03-04, BW'S NAKED 50 2T 09-16, BW'S NEXT GENERATION 50 2T 97-06, BW'S ORIGINAL 50 2T 99-01, BW'S ORIGINAL EURO 2 50 2T 03-03, JOG R 50 2T 02-02, JOG R EURO2 50 2T 02-02, JOG R EURO2 50 2T 06-15, JOG R LC 50 2T 02-15, NEO'S EURO 2 50 2T 02-02, RS SPY 50 2T 95-98, SLIDER 50 2T 00-02, ZUMA 50 2T 97-01

REGOLATORE DI PRESSIONE



◀ **cod. 9928130**
Regolatore di pressione 3.5 bar

APPLICABILITÀ

MBK BOOSTER X IE 50 4T-3V 08-08

YAMAHA GIGGLE 50 4T-3V 08-08, YZF-R IE 125 4T 4V IE 08-13, T-MAX 4B5 500 4T 09-11, T-MAX 4B5 ABS 500 4T 08-11, T-MAX 5VU 500 4T 06-06, T-MAX 5VU 500 4T 08-08, T-MAX 59C 530 4T 12-16, T-MAX 59C ABS 530 4T 12-16, T-MAX 59C SP 530 4T 15-15, T-MAX 59C SP ABS 530 4T 15-16

SCARICHI COMPLETI



◀ cod. **9927350** **RACING**
Scarico completo Yamaha YZF 125 R

APPLICABILITÀ
YAMAHA YZF-R IE 125 4T 4V IE 08-13



◀ cod. **9924340** **RACING**
Scarico ad espans. per HM CRE SIX 50'06

APPLICABILITÀ
HM BAJA, DERAPAGE BASIC 50 2T 10-11, CMC 50 2T 10-11, CRE BAJA RR, DERAPAGE RR 50 2T 07-11, CRE BAJA, DERAPAGE 50 2T 07-11, CRE SIX COMPETITION 50 2T 10-11, CRE SIX, BAJA, DERAPAGE 50 2T 95-06, CRE SIX, DERAPAGE COMPETITION 50 2T 07-09, DERAPAGE COMPETITION 50 2T 10-11

VENT BAJA 50 2T 18-20, BAJA RR 50 2T 18-20, DERAPAGE 50 2T 18-20, DERAPAGE RR 50 2T 18-20

RICAMBI

9924350	Silenziatore
---------	--------------

SCARICHI GP



◀ cod. **9930140** **RACING**
Scarico "TPR" GP Minarelli/Yamaha
Da abbinare ai Maxi Kit Scooter 50 cc. Minarelli/Yamaha LC | cod.9926560 e 9926580

APPLICABILITÀ
APRILIA AREA 51 50 2T 98-00, GULLIVER LC 50 2T 96-98, RALLY LIQUID COOLED 50 2T 96-99, SONIC GP 50 2T 98-08, SR LIQUID COOLED 50 2T 94-96, SR RACING 50 2T 97-99, SR STEALTH 50 2T 97-00
BENELLI 491 RACING 50 2T 98-99, 491 RR 50 2T 99-01, 491 SP 50 2T 99-99, 491 SPORT 50 2T 98-99, K2 LIQUID COOLED 50 2T 98-01
BETA ARK LC 50 2T 96-08, EIKON 50 2T 99-03
ITALJET DRAGSTER 50 2T 98-02

MALAGUTI F12 PHANTOM LC 50 2T 94-98, F12 R PHANTOM LC 50 2T 07-10, F15 FIRE FOX 50 2T 96-98, F15 FIRE FOX EURO 2 50 2T 02-06, F15 FIRE FOX EURO 2,3 50 2T 03-04

MBK MACH G LC 50 2T 02-04, NITRO 50 2T 97-04, NITRO EURO 2 50 2T 03-03

YAMAHA AEROX 50 2T 97-02, AEROX 50 2T 04-16, AEROX EURO 2 50 2T 03-03, AEROX NAKED 50 2T 13-16, AEROX R 50 2T 99-00, JOG R LC 50 2T 02-15

RICAMBI

9930550	Kit staffa fissaggio
9930590	Kit collettore

9930670	Silenziatore
9930680	Serie guarnizioni



◀ cod. **9930160** **RACING**
Scarico "TPR" GP Piaggio
Da abbinare ai Maxi Kit Scooter 50 cc. Piaggio | cod. 9928390 e 9928340

APPLICABILITÀ
APRILIA SR MOTARD 50 2T 12-14, SR R 50 2T 04-09, SR R FACTORY CARBURATORE 50 2T 10-14, SR R FACTORY IE 50 2T 10-14
DERBI GP1 50 2T 01-03, GP1 EU 2 50 2T 05-05, GP1 OPEN EU2 50 2T 06-09, GP1 RACE EU2 50 2T 05-07
GILERA DNA 50 2T 00-02, DNA 50 2T 05-07, DNA GP EXPERIENCE 50 2T 03-04, RUNNER 50 2T 97-00, RUNNER POGGIALI 50 2T 02-02, RUNNER SP 50 2T 02-07, RUNNER SP 50 2T 10-12, RUNNER SP SPECIAL EDITION 50 2T 07-07, RUNNER SP ST & SIMONCELLI 50 2T 08-09

PIAGGIO NRG 50 2T 94-96, NRG EXTREME LC 50 2T 99-00, NRG MC3 50 2T 01-04, NRG POWER DD 50 2T 05-17, NRG POWER DD SERIE SPECIALE 50 2T 07-12, NRG RST MC2 50 2T 96-98, NTT 50 2T 95-96, QUARTZ 50 2T 92-96, ZIP 2T 50 2T 08-13, ZIP LC 50 2T 00-04, ZIP SP 50 2T 96-04, ZIP SP EURO 2 50 2T 06-13

RICAMBI

9930670	Silenziatore
9930680	Serie guarnizioni

9930730	Kit staffa fissaggio
9930750	Kit collettore

SCARICHI NARDÒ 2



cod. **9931440** **RACING**
 Scarico Nardò 2 omologato per motore orizzontale

APPLICABILITÀ

Attenzione: lo scarico è omologato esclusivamente per i modelli evidenziati in grassetto

APRILIA AREA 51 50 2T 98-00, GULLIVER 50 2T 95-98, GULLIVER LC 50 2T 96-98, RALLY 50 2T 95-03, RALLY LIQUID COOLED 50 2T 96-99, SCARABEO 50 2T 93-98, SONIC 50 2T 98-07, SONIC GP 50 2T 98-08, SR (ORIZZONTALE) 50 2T 94-96, SR LIQUID COOLED 50 2T 94-96, SR RACING 50 2T 97-99, SR STEALTH 50 2T 97-00, SR WWW 50 2T 97-01

BENELLI 491 GT 50 2T 98-99, 491 RACING 50 2T 98-99, K2 50 2T 98-01, K2 LIQUID COOLED 50 2T 98-01, PEPE 50 2T 99-01

BETA ARK 50 2T 96-08, ARK LC 50 2T 96-08, CHRONO 50 2T 95-96, EIKON 50 2T 99-03, QUADRA 50 2T 95-95, QUADRA 50 2T 99-01, TEMPO 50 2T 93-02, TEMPO 50 2T 95-95

ITALJET DRAGSTER 50 2T 98-02

MALAGUTI CENTRO SL 50 2T 94-98, CIAK 50 2T 99-01, CIAK EURO 2,3 50 2T 03-03, CIAK EURO2 50 2T 01-03, CIAK MASTER EURO 2 50 2T 06-06, F10 50 2T 92-00, F10 EURO 2 50 2T 02-06, F10 EURO 2,3 50 2T 03-04, F10 RESTYLING EURO 2 50 2T 06-06, F12 PHANTOM 50 2T 94-98, F12 PHANTOM EURO 2,3 50 2T 03-04, F12 PHANTOM LC 50 2T 94-98, F12 R PHANTOM LC 50 2T 07-10, F12 RESTYLING EURO 2 50 2T 06-06, F15 FIRE FOX 50 2T 96-98, F15 FIRE FOX AIR COOLED 50 2T 05-06, F15 FIRE FOX EURO 2 50 2T 02-06, F15 FIRE FOX EURO 2,3 50 2T 03-04, YESTERDAY 50 2T 97-00

MBK EVOLIS 50 2T 92-95, FIZZ 50 2T 94-95, FLIPPER 50 2T 98-04, FLIPPER EURO 2 50 2T 03-03, FORTE 50 2T 94-96, MACH G 50 2T 02-04, MACH G LC 50 2T 02-04, NITRO 50 2T 97-04, NITRO EURO 2 50 2T 03-03, OVETTO 50 2T 97-04, OVETTO EURO 2 50 2T 02-02

YAMAHA AEROX 50 2T 97-02, AEROX 50 2T 04-16, AEROX EURO 2 50 2T 03-03, AEROX NAKED 50 2T 13-16, AEROX R 50 2T 99-00, AXIS 50 2T 95-96, BREEZE 50 2T 94-95, JOG 50 2T 92-01, JOG ER 50 2T 00-02, JOG R 50 2T 02-02, JOG R EURO2 50 2T 02-02, JOG R EURO2 50 2T 06-15, JOG R LC 50 2T 02-15, JOG Z 50 2T 95-95, NEO'S 50 2T 97-02, NEO'S 50 2T 04-16, NEO'S EASY 50 2T 13-13, NEO'S EURO 2 50 2T 02-02, WHY 50 2T 98-05, WHY EURO 2 50 2T 03-05, ZEST 50 2T 95-92

RICAMBI

9931530 Silenziatore

9931470 Kit staffa

cod. **9931450** **RACING**
 Scarico Nardò 2 omologato per motore verticale

Attenzione: lo scarico è omologato esclusivamente per i modelli evidenziati in grassetto

APPLICABILITÀ

APRILIA AMICO 50 2T 94-94, AMICO 50 2T 96-98, AMICO GL/GLE 50 2T 93-95, AMICO LX/SPORT/CAT 50 2T 92-93, SR (VERTICALE) 50 2T 93-93

ITALJET BAZOOKA 50 2T 91-94, PISTA 50 2T 92-97, PISTA 2 50 2T 97-98, SCOOP 50 2T 91-95, SCOOP 2 50 2T 96-98, YANKEE 50 2T 93-97

YAMAHA BW'S 50 2T 97-04, BW'S BUMP 50 2T 97-98, BW'S NAKED 50 2T 03-03, BW'S NEXT GENERATION 50 2T 97-02, BW'S ORIGINAL 50 2T 99-01, RS SPY 50 2T 95-98, SLIDER 50 2T 00-02, ZUMA 50 2T 97-01

MBK BOOSTER 50 2T 90-04, BOOSTER 50 2T 90-94, BOOSTER NG 50 2T 95-03, BOOSTER ROCKET 50 2T 97-98, BOOSTER SPIRIT 50 2T 96-00, BOOSTER TRACK 50 2T 96-98, STUNT 50 2T 00-02

RICAMBI

9931530 Silenziatore

9931490 Kit staffa

cod. **9931460** **RACING**
 Scarico Nardò 2 omologato per motore Piaggio 50 cc

Attenzione: lo scarico è omologato esclusivamente per i modelli evidenziati in grassetto

APPLICABILITÀ

APRILIA SCARABEO 2T EU2 MOTORE PIAGGIO 50 2T 10-12, SCARABEO 2T NET 50 2T 09-10, SCARABEO STREET 50 2T 05-06, SCARABEO STREET 2T RESTYLING 50 2T 06-09, SR MOTARD 50 2T 12-14, SR R 50 2T 04-09, SR R FACTORY CARBURATORE 50 2T 10-14, SR R FACTORY IE 50 2T 10-14

DERBI ATLANTIS 2T 50 2T 10-10, ATLANTIS 2T EU2 50 2T 07-09, ATLANTIS 02 50 2T 02-02, ATLANTIS 02 BULLET 50 2T 03-05, ATLANTIS 02 CITY 50 2T 04-06, ATLANTIS 02 RED BULLET 50 2T 03-03, ATLANTIS 02 TWO CHIC 50 2T 05-05, BOULEVARD 2T 50 2T 09-14, GP1 50 2T 01-03, GP1 EU 2 50 2T 05-05, GP1 OPEN EU2 50 2T 06-09, GP1 RACE EU2 50 2T 05-07, SONAR 2T 50 2T 09-09

GILERA DNA 50 2T 00-02, DNA 50 2T 05-07, DNA GP EXPERIENCE 50 2T 03-04, EASY MOVING 50 2T 95-96, ICE 50 2T 01-05, RUNNER 50 2T 97-00, RUNNER POGGIALI 50 2T 02-02, RUNNER PURE JET 50 2T-IE 02-07, RUNNER PURE JET 50 2T-IE 10-11, RUNNER PURE JET ST 50 2T-IE 08-08, RUNNER SP 50 2T 02-07, RUNNER SP 50 2T 10-12, RUNNER SP SPECIAL EDITION 50 2T 07-07, RUNNER SP ST & SIMONCELLI 50 2T 08-09, STALKER 50 2T 97-11, STALKER NAKED 50 2T 08-08, STALKER SPECIAL EDITION 50 2T 07-08, STORM 50 2T 94-95, STORM EURO 2 50 2T 07-07, TYPHOON 50 2T 94-97, TYPHOON X 50 2T 98-99, TYPHOON XR 50 2T 00-00

PIAGGIO DIE SIS 50 2T 01-01, FLY 2T 50 2T 05-07, FLY 2T 50 2T 10-11, FREE 50 2T 92-94, FREE DELIVERY 50 2T 00-01, FREE FL 50 2T 95-02, LIBERTY 50 2T 97-05, LIBERTY 2T 50 2T 06-08, LIBERTY 2T PTT EU2 50 2T 04-05, LIBERTY 2T RST 50 2T 04-04, LIBERTY 2T SPORT 50 2T 06-08, LIBERTY MOC 2T & ELLE 50 2T 09-13, NRG 50 2T 94-96, NRG EXTREME LC 50 2T 99-00, NRG MC3 50 2T 01-04, NRG POWER DD 50 2T 05-17, NRG POWER DD SERIE SPECIALE 50 2T 07-12, NRG POWER DT 50 2T 06-15, NRG POWER DT SERIE SPECIALE 50 2T 07-08, NRG POWER PUREJET 50 2T-IE 04-11, NRG PUREJET 50 2T-IE 02-04, NRG PUREJET 50 2T-IE 10-10, NRG RST MC2 50 2T 96-98, NTT 50 2T 95-96, QUARTZ 50 2T 92-96, SFERA 50 2T 91-93, SFERA MAQUILLAGE 2 50 2T 94-94, SFERA RST 50 2T 95-97, TYPHOON 50 2T 01-11, TYPHOON 2T E2 50 2T 10-12, TYPHOON 2T E3 CH 50 2T 11-11, VESPA ET2 50 2T 97-05, VESPA ET2 INIEZIONE 50 2T 97-00, VESPA LX 2T 50 2T 05-13, VESPA LX 2T TOURING & 30KM 50 2T 10-13, VESPA LXV 2T 50 2T 06-09, VESPA LXV 2T NAVY 50 2T 08-08, VESPA S 2T & COLLEGE 50 2T 07-12, ZIP 50 2T 92-93, ZIP 50 2T 95-96, ZIP 2T 50 2T 08-13, ZIP BIMODALE 50 2T 94-97, ZIP FAST RIDER 50 2T 93-94, ZIP FAST RIDER RST 50 2T 96-97, ZIP LC 50 2T 00-04, ZIP RST 50 2T 96-99, ZIP SP 50 2T 96-04, ZIP SP EURO 2 50 2T 06-13

ITALJET JET SET 50 2T 02-02, TORPEDO NEW 50 2T 00-01

RICAMBI

9931530 Silenziatore

9931510 Kit staffa



cod. **9934190**
 Collettore per scarico Nardò 2 per motori Minarelli/Yamaha orizzontale interasse 51 mm

cod. **9934210**
 Collettore per scarico Nardò 2 per motore Piaggio interasse 51 mm

ATTENZIONE: QUESTI PRODOTTI SONO DESTINATI ESCLUSIVAMENTE AD USO AGONISTICO. NE È QUINDI VIETATO L'UTILIZZO SU STRADA PUBBLICA.



◀ **cod. 9906520**

Valvola lamellare con petali in fibra di carbonio (spessore 0,30 mm) per motori scooter 50 cc Minarelli/Yamaha tipo verticale

APPLICABILITÀ

APRILIA AMICO 50 2T 94-94, AMICO 50 2T 96-98, AMICO GL/GLE 50 2T 93-95, AMICO LX/SPORT/CAT 50 2T 92-93, SR (VERTICALE) 50 2T 93-93
MBK BOOSTER 50 2T 90-04, BOOSTER 50 2T 90-94, BOOSTER EURO 2 50 2T 04-04, BOOSTER NG 50 2T 95-03, BOOSTER ROCKET 50 2T 97-98, BOOSTER SPIRIT 50 2T 96-00, BOOSTER SPIRIT 50 2T 03-03, BOOSTER SPIRIT EURO2 50 2T 03-03, BOOSTER TRACK 50 2T 96-98, STUNT 50 2T 00-02

YAMAHA BW'S 50 2T 97-16, BW'S BUMP 50 2T 97-98, BW'S EASY 50 2T 13-13, BW'S NAKED 50 2T 03-04, BW'S NAKED 50 2T 09-16, BW'S NEXT GENERATION 50 2T 97-06, BW'S ORIGINAL 50 2T 99-01, BW'S ORIGINAL EURO 2 50 2T 03-03, RS SPY 50 2T 95-98, SLIDER 50 2T 00-02, ZUMA 50 2T 97-01

RICAMBI

9910480 Petalo in carbonio 0,30 mm

9908870 Petalo in carbonio 0,40 mm



◀ **cod. 9908370**

Valvola lamellare con petali in fibra di carbonio (spessore 0,30 mm) per motori scooter 50 cc Minarelli/Yamaha tipo orizzontale

APPLICABILITÀ

APRILIA AREA 51 50 2T 98-00, GULLIVER 50 2T 95-98, GULLIVER LC 50 2T 96-98, RALLY 50 2T 95-03, RALLY LIQUID COOLED 50 2T 96-99, SCARABEO 50 2T 93-05, SONIC 50 2T 98-07, SONIC GP 50 2T 98-08, SR (ORIZZONTALE) 50 2T 94-96, SR LIQUID COOLED 50 2T 94-96, SR RACING 50 2T 97-99, SR STEALTH 50 2T 97-00, SR WWW 50 2T 97-01

ATALA CAROSELLO 50 2T 99-01

BENELLI 491 GT 50 2T 98-99, 491 NAKED 50 2T 02-02, 491 RACING 50 2T 98-99, 491 RR 50 2T 99-01, 491 SP 50 2T 99-99, 491 SPORT 50 2T 98-99, 491 ST 50 2T 99-01, K2 50 2T 98-01, K2 LIQUID COOLED 50 2T 98-01, PEPE 50 2T 99-01, PEPE LX 50 2T 03-04

BETA ARK 50 2T 96-08, ARK LC 50 2T 96-08, CHRONO 50 2T 95-96, EIKON 50 2T 99-03, QUADRA 50 2T 95-95, QUADRA 50 2T 99-01, TEMPO 50 2T 93-02, TEMPO 50 2T 95-95

DINLI HELIX DL603 50 2T 07-13, HELIX DL603 90 50 2T 07-13, T-REX 50 2T 07-13

E-TON VIPER RXL 50 2T 06-06

ITALJET DRAGSTER 50 2T 98-02

KEEWAY ATV EC2 50 2T 06-06, ATV OFF ROAD 50 2T 07-07

KTM K50 50 2T 96-01

LAVERDA QUASAR 50 2T 02-04

MACAL THUNDER 50 2T 95-96

MALAGUTI CENTRO SL 50 2T 94-98, CIAK 50 2T 99-01, CIAK EURO 2 2.3 50 2T 03-03, CIAK EURO2 50 2T 01-03, CIAK MASTER EURO 2 50 2T 06-06, F10 50 2T 92-00, F10 EURO 2 50 2T 02-06, F10 EURO 2.3 50 2T 03-04, F10 RESTYLING EURO 2 50 2T 06-06, F12 PHANTOM 50 2T 94-98, F12 PHANTOM EURO 2 50 2T 02-02, F12 PHANTOM EURO 2 2.3 50 2T 03-04, F12 PHANTOM LC 50 2T 94-98, F12 PHANTOM LC EURO 2.3 50 2T 03-04, F12 R PHANTOM LC 50 2T 07-10, F12 RESTYLING EURO 1 50 2T 99-02, F12 RESTYLING EURO 2 50 2T 06-06, F12 RESTYLING LC EURO 2 50 2T 06-06, F15 FIRE FOX 50 2T 96-98, F15 FIRE FOX AIR COOLED 50 2T 05-06, F15 FIRE FOX EURO 2 50 2T 02-06, F15 FIRE FOX EURO 2.3 50 2T 03-04, YESTERDAY 50 2T 97-00

MBK EVOLIS 50 2T 92-95, FIZZ 50 2T 94-95, FLIPPER 50 2T 98-04, FLIPPER EURO 2 50 2T 03-03, FORTE 50 2T 94-96, MACH G 50 2T 02-04, MACH G LC 50 2T 02-04, NITRO 50 2T 97-04, NITRO EURO 2 50 2T 03-03, OVETTO 50 2T 97-04, OVETTO EURO 2 50 2T 02-02

MOTRON SYNCRO 50 2T 98-00, THUNDER 50 2T 95-98

RIEJU FIRST 50 2T 95-98, WINDY 50 2T 95-98

YAMAHA AEROX 50 2T 97-02, AEROX 50 2T 04-16, AEROX EURO 2 50 2T 03-03, AEROX NAKED 50 2T 13-16, AEROX R 50 2T 99-00, AXIS 50 2T 95-96, BREEZE 50 2T 94-95, JOG 50 2T 92-01, JOG ER 50 2T 00-02, JOG R 50 2T 02-02, JOG R EURO2 50 2T 02-02, JOG R EURO2 50 2T 06-15, JOG R LC 50 2T 02-15, JOG Z 50 2T 95-95, NEO'S 50 2T 97-02, NEO'S 50 2T 04-16, NEO'S EASY 50 2T 13-13, NEO'S EURO 2 50 2T 02-02, WHY 50 2T 98-05, WHY EURO 2 50 2T 03-05, ZEST 50 2T 95-92, ZUMA 50 2T 02-10

RICAMBI

9910500 Coppia petali in carbonio 0,30 mm

9908880 Coppia petali in carbonio 0,25 mm



◀ **cod. 9910930**

Valvola lamellare con petali in fibra di carbonio (spessore 0,35 mm) per motore scooter 50 cc Gilera/Piaggio

APPLICABILITÀ

APRILIA MOJITO CUSTOM 2T MOTORE PIAGGIO 50 2T 04-10, SCARABEO 2T EU2 MOTORE PIAGGIO 50 2T 10-12, SCARABEO 2T NET 50 2T 09-10, SCARABEO STREET 50 2T 05-06, SCARABEO STREET 2T RESTYLING 50 2T 06-09, SPORT CITY ONE 2T 50 2T 08-11, SR MOTARD 50 2T 12-14, SR R 50 2T 04-09, SR R FACTORY CARBURATORE 50 2T 10-14, SR R FACTORY IE 50 2T 10-14, SR STREET CARBURATORE 50 2T 03-12

DERBI ATLANTIS 2T 50 2T 10-10, ATLANTIS 2T EU2 50 2T 07-09, ATLANTIS O2 50 2T 02-02, ATLANTIS O2 BULLET 50 2T 03-05, ATLANTIS O2 CITY 50 2T 04-06, ATLANTIS O2 RED BULLET 50 2T 03-03, ATLANTIS O2 TWO CHC 50 2T 05-05, BOULEVARD 2T 50 2T 09-14, GP1 50 2T 01-03, GP1 EU 2 50 2T 05-05, GP1 OPEN EU2 50 2T 06-09, GP1 RACE EU2 50 2T 05-07, SONAR 2T 50 2T 09-09

GILERA DNA 50 2T 00-02, DNA 50 2T 05-07, DNA GP EXPERIENCE 50 2T 03-04, EASY MOVING 50 2T 95-96, ICE 50 2T 01-05, RUNNER 50 2T 97-00, RUNNER POGGIALI 50 2T 02-02, RUNNER PURE JET 50 2T-IE 02-07, RUNNER PURE JET 50 2T-IE 10-11, RUNNER PURE JET ST 50 2T-IE 08-08, RUNNER SP 50 2T 02-07, RUNNER SP 50 2T 10-12, RUNNER SP SPECIAL EDITION 50 2T 07-07, RUNNER SP ST & SIMONCELLI 50 2T 08-09, STALKER 50 2T 97-11, STALKER NAKED 50 2T 08-08, STALKER SPECIAL EDITION 50 2T 07-08, STORM 50 2T 94-95, STORM EURO 2 50 2T 07-07, TYPHOON 50 2T 94-97, TYPHOON X 50 2T 98-99, TYPHOON XR 50 2T 00-00

ITALJET JET SET 50 2T 02-02, TORPEDO NEW 50 2T 00-01

PIAGGIO DIESEL 50 2T 01-01, FLY 2T 50 2T 05-07, FLY 2T 50 2T 10-11, FREE 50 2T 92-94, FREE DELIVERY 50 2T 00-01, FREE FL 50 2T 95-02, LIBERTY 50 2T 97-05, LIBERTY 2T 50 2T 06-08, LIBERTY 2T PTT EU2 50 2T 04-05, LIBERTY 2T RST 50 2T 04-04, LIBERTY 2T SPORT 50 2T 06-08, LIBERTY MOC 2T & ELLE 50 2T 09-13, NRG 50 2T 94-96, NRG EXTREME LC 50 2T 99-00, NRG MC3 50 2T 01-04, NRG POWER DD 50 2T 05-17, NRG POWER DD SERIE SPECIALE 50 2T 07-12, NRG POWER DT 50 2T 06-15, NRG POWER DT SERIE SPECIALE 50 2T 07-08, NRG POWER PUREJET 50 2T-IE 04-11, NRG PUREJET 50 2T-IE 02-04, NRG PUREJET 50 2T-IE 10-10, NRG RST MC2 50 2T 96-98, NTT 50 2T 95-96, QUARTZ 50 2T 92-96, SFERA 50 2T 91-93, SFERA MAQUILLAGE 2 50 2T 94-94, SFERA RST 50 2T 95-97, TYPHOON 50 2T 01-11, TYPHOON 2T E2 50 2T 10-12, TYPHOON 2T E3 CH 50 2T 11-11, VESPA ET2 50 2T 97-05, VESPA ET2 INIEZIONE 50 2T 97-00, VESPA LX 2T 50 2T 05-13, VESPA LX 2T TOURING & 30KM 50 2T 10-13, VESPA LXV 2T 50 2T 06-09, VESPA LXV 2T NAVY 50 2T 08-08, VESPA S 2T & COLLEGE 50 2T 07-12, ZIP 50 2T 92-93, ZIP 50 2T 95-96, ZIP 2T 50 2T 08-13, ZIP BIMODALE 50 2T 94-97, ZIP FAST RIDER 50 2T 93-94, ZIP FAST RIDER RST 50 2T 96-97, ZIP LC 50 2T 00-04, ZIP RST 50 2T 96-99, ZIP SP 50 2T 96-04, ZIP SP EURO 2 50 2T 06-13

RICAMBI

9911290 Coppia petali in carbonio 0,30 mm

9911300 Coppia petali in carbonio 0,35 mm



◀ cod. 9912550

Valvola lamellare con petali in fibra di carbonio (spessore 0,30 mm) per motore scooter 50 cc Peugeot

APPLICABILITÀ

BSV	DIO GP 50 2T 94-96, DIO SP 50 2T 94-96, DIO ZX 50 2T 94-96
HONDA	BALI 50 2T 93-99, DIO SR 50 2T 92-00, DIO ZX 50 2T 94-96, LEAD 50 2T 89-90, MET IN 50 2T 90-92, SFX / SXR 50 2T 95-01, SGX SKY 50 2T 97-04, SH 50 2T 84-89, SH NEW 50 2T 96-01, SHADOW 50 2T 98-01, VISION 50 2T 88-95, X8R S 50 2T 98-01, X8R X 50 2T 98-01
HSC	SC 01 50 2T 94-96, SC 01 L 50 2T 94-96

KYMCO CX 50 2T 93-93, CX SUPER 50 2T 94-97, DJ WORLD 50 2T 94-00, DJ Y 50 2T 93-93, FEVER ZX 50 2T 99-00, FEVER ZX EU 50 2T 03-04, K 12 50 2T 95-00, KB 50 2T 95-00

PEUGEOT BUXY 50 2T 90-02, BUXY RS 50 2T 90-02, ELYSEO 50 2T 90-02, LOOXOR 50 2T 90-02, METAL X 50 2T 90-02, METROPOLIS 50 2T 90-02, RAPIDO 50 2T 90-02, SPEEDAKE 50 2T 90-02, SPEEDFIGHT 50 2T 97-04, SPEEDFIGHT LC 50 2T 97-04, SQUAB 50 2T 90-02, ST 50 2T 90-02, SV GEO 50 2T 90-02, TREKKER 50 2T 90-02, VIVACITY 50 2T 90-02, X-FIGHT 50 2T 00-02, X-FIGHT LC 50 2T 00-02, ZENITH 50 2T 90-02

SYM

DD 50 2T 02-02

RICAMBI

9912970	Petalo in carbonio 0,30 mm
---------	----------------------------

9912980	Petalo in carbonio 0,35 mm
---------	----------------------------

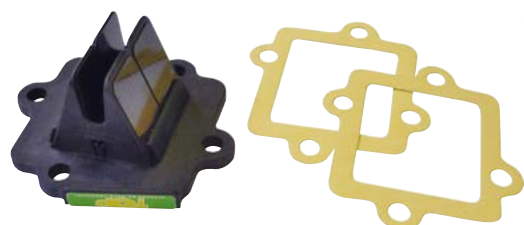

◀ cod. 9931620

RACING

Valvola lamellare "TPR" black ad 8 petali in carbonio (spessore 0,30 mm) per motori scooter 50 cc Minarelli/Yamaha orizzontale

APPLICABILITÀ

APRILIA	AREA 51 50 2T 98-00, GULLIVER 50 2T 95-98, GULLIVER LC 50 2T 96-98, RALLY 50 2T 95-03, RALLY LIQUID COOLED 50 2T 96-99, SCARABEO 50 2T 93-05, SONIC 50 2T 98-07, SONIC GP 50 2T 98-08, SR (ORIZZONTALE) 50 2T 94-96, SR LIQUID COOLED 50 2T 94-96, SR RACING 50 2T 97-99, SR STEALTH 50 2T 97-00, SR WWW 50 2T 97-01
ATALA	CAROSSELLO 50 2T 99-01
BENELLI	491 GT 50 2T 98-99, 491 NAKED 50 2T 02-02, 491 RACING 50 2T 98-99, 491 RR 50 2T 99-01, 491 SP 50 2T 99-99, 491 SPORT 50 2T 98-99, 491 ST 50 2T 99-01, K2 50 2T 98-01, K2 LIQUID COOLED 50 2T 98-01, PEPE 50 2T 99-01, PEPE 50 2T 10-10, PEPE LX 50 2T 03-04, PEPE LX 50 2T 07-09, PEPE OLD 50 2T 07-09, PEPE OLD 50 2T 11-11, QUATTRONEX 50 2T 08-11
BETA	ARK 50 2T 96-08, ARK LC 50 2T 96-08, CHRONO 50 2T 95-96, EIKON 50 2T 99-03, QUADRA 50 2T 95-95, QUADRA 50 2T 99-01, TEMPO 50 2T 93-02, TEMPO 50 2T 95-95
CPI	ARAGON 50 2T 03-03, HUSSAR 50 2T 03-03, OLIVER 50 2T 03-03, POP CORN 50 2T 03-03
EXPLORER	CRACKER 50 2T 03-03
ITALJET	DRAGSTER 50 2T 98-02
KEEWAY	F-ACT 50 2T 07-08, FLASH 50 2T 07-08, FOCUS 50 2T 06-06, GOCCIA 50 2T 09-09, HURRICANE 50 2T 06-08, MATRIX 50 2T 06-08, PIXEL EURO 2 50 2T 09-12, RY8 50 2T 08-08
KTM	K50 50 2T 96-01

MACAL THUNDER 50 2T 95-96

MALAGUTI CENTRO SL 50 2T 94-98, CIAK 50 2T 99-01, CIAK EURO 2 2,3 50 2T 03-03, CIAK EURO2 50 2T 01-03, CIAK MASTER EURO 2 50 2T 06-06, F10 50 2T 92-00, F10 ACWAP 50 2T 08-08, F10 EURO 2 50 2T 02-06, F10 EURO 2 2,3 50 2T 03-04, F10 RESTYLING EURO 2 50 2T 06-06, F12 PHANTOM 50 2T 94-98, F12 PHANTOM EURO 2 50 2T 02-02, F12 PHANTOM EURO 2 2,3 50 2T 03-04, F12 PHANTOM LC 50 2T 94-98, F12 PHANTOM LC EURO 2 2,3 50 2T 03-04, F12 R PHANTOM AC 50 2T 07-08, F12 R PHANTOM LC 50 2T 07-10, F12 RESTYLING EURO 1 50 2T 99-02, F12 RESTYLING EURO 2 50 2T 06-06, F12 RESTYLING LC EURO 2 50 2T 06-06, F15 FIRE FOX 50 2T 96-98, F15 FIRE FOX AIR COOLED 50 2T 05-06, F15 FIRE FOX EURO 2 50 2T 02-06, F15 FIRE FOX EURO 2 2,3 50 2T 03-04, YESTERDAY 50 2T 97-00

MBK EVOLIS 50 2T 92-95, FIZZ 50 2T 94-95, FLIPPER 50 2T 98-04, FLIPPER EURO 2 50 2T 03-03, FORTE 50 2T 94-96, MACH G 50 2T 02-04, MACH G LC 50 2T 02-04, NITRO 50 2T 97-04, NITRO EURO 2 50 2T 03-03, OVETTO 50 2T 97-04, OVETTO EURO 2 50 2T 02-02

MOTRON SYNCRO 50 2T 98-00, THUNDER 50 2T 95-98

RIEJU FIRST 50 2T 95-98, WINDY 50 2T 95-98

YAMAHA AEROX 50 2T 97-02, AEROX 50 2T 04-16, AEROX EURO 2 50 2T 03-03, AEROX NAKED 50 2T 13-16, AEROX R 50 2T 99-00, AXIS 50 2T 95-96, BREEZE 50 2T 94-95, JOG 50 2T 92-01, JOG R 50 2T 02-02, JOG R EURO2 50 2T 02-02, JOG R EURO2 50 2T 06-15, JOG R LC 50 2T 02-15, NEO'S 50 2T 97-02, NEO'S 50 2T 04-16, NEO'S EASY 50 2T 13-13, NEO'S EURO 2 50 2T 02-02, WHY 50 2T 98-05, WHY EURO 2 50 2T 03-05, ZEST 50 2T 95-92

RICAMBI

9933790	Petalo in carbonio 0,30 mm
---------	----------------------------



◀ **cod. 9931640** **RACING**

Valvola lamellare "TPR" black ad 8 petali in carbonio (spessore 0,30 mm) per motori scooter 50 cc Piaggio/Gilera

APPLICABILITÀ

- APRILIA** MOJITO CUSTOM 2T MOTORE PIAGGIO 50 2T 04-10, SCARABEO 2T EU2 MOTORE PIAGGIO 50 2T 10-12, SCARABEO 2T NET 50 2T 09-10, SCARABEO STREET 50 2T 05-06, SCARABEO STREET 2T RESTYLING 50 2T 06-09, SPORT CITY ONE 2T 50 2T 08-11, SR MOTARD 50 2T 12-14, SR R 50 2T 04-09, SR R FACTORY CARBURATORE 50 2T 10-14, SR R FACTORY IE 50 2T 10-14, SR STREET CARBURATORE 50 2T 03-12
- DERBI** ATLANTIS 2T 50 2T 10-10, ATLANTIS 2T EU2 50 2T 07-09, ATLANTIS O2 50 2T 02-02, ATLANTIS O2 BULLET 50 2T 03-05, ATLANTIS O2 CITY 50 2T 04-06, ATLANTIS O2 RED BULLET 50 2T 03-03, ATLANTIS O2 TWO CHIC 50 2T 05-05, BOULEVARD 2T 50 2T 09-14, GP1 50 2T 01-03, GP1 EU 2.50 2T 05-05, GP1 OPEN EU2 50 2T 06-09, GP1 RACE EU2 50 2T 05-07, SONAR 2T 50 2T 09-09
- GILERA** DNA 50 2T 00-02, DNA 50 2T 05-07, DNA GP EXPERIENCE 50 2T 03-04, EASY MOVING 50 2T 95-96, ICE 50 2T 01-05, RUNNER 50 2T 97-00, RUNNER POGGIALI 50 2T 02-02, RUNNER PURE JET 50 2T-IE 02-07, RUNNER PURE JET 50 2T-IE 10-11, RUNNER PURE JET ST 50 2T-IE 08-08, RUNNER SP 50 2T 02-07, RUNNER SP 50 2T 10-12, RUNNER SP SPECIAL EDITION 50 2T 07-07, RUNNER SP ST & SIMONCELLI 50 2T 08-09, STALKER 50 2T 97-11, STALKER NAKED 50 2T 08-08, STALKER SPECIAL EDITION 50 2T 07-08, STORM 50 2T 94-95, STORM EURO 2.50 2T 07-07, TYPHOON 50 2T 94-97, TYPHOON X 50 2T 98-99, TYPHOON XR 50 2T 00-00

**ITALJET
PIAGGIO**

- JET SET 50 2T 02-02, TORPEDO NEW 50 2T 00-01
- DIESEL** 50 2T 01-01, FLY 2T 50 2T 05-07, FLY 2T 50 2T 10-11, FREE 50 2T 92-94, FREE DELIVERY 50 2T 00-01, FREE FL 50 2T 95-02, LIBERTY 50 2T 97-05, LIBERTY 2T 50 2T 06-08, LIBERTY 2T PTT EU2 50 2T 04-05, LIBERTY 2T RST 50 2T 04-04, LIBERTY 2T SPORT 50 2T 06-08, LIBERTY MOC 2T & ELLE 50 2T 09-13, NRG 50 2T 94-96, NRG EXTREME LC 50 2T 99-00, NRG MC3 50 2T 01-04, NRG POWER DD 50 2T 05-17, NRG POWER DD SERIE SPECIALE 50 2T 07-12, NRG POWER DT 50 2T 06-15, NRG POWER DT SERIE SPECIALE 50 2T 07-08, NRG POWER PUREJET 50 2T-IE 04-11, NRG PUREJET 50 2T-IE 02-04, NRG PUREJET 50 2T-IE 10-10, NRG RST MC2 50 2T 96-98, NTT 50 2T 95-96, QUARTZ 50 2T 92-96, SFERA 50 2T 91-93, SFERA MAQUILLAGE 2.50 2T 94-94, SFERA RST 50 2T 95-97, TYPHOON 50 2T 01-11, TYPHOON 2T E2 50 2T 10-12, TYPHOON 2T E3 CH 50 2T 11-11, VESPA ET2 50 2T 97-05, VESPA ET2 INIEZIONE 50 2T 97-00, VESPA LX 2T 50 2T 05-13, VESPA LX 2T TOURING & 30KM 50 2T 10-13, VESPA LXV 2T 50 2T 06-09, VESPA LXV 2T NAVY 50 2T 08-08, VESPA S 2T & COLLEGE 50 2T 07-12, ZIP 50 2T 92-93, ZIP 50 2T 95-96, ZIP 2T 50 2T 08-13, ZIP BIMODALE 50 2T 94-97, ZIP FAST RIDER 50 2T 93-94, ZIP FAST RIDER RST 50 2T 96-97, ZIP LC 50 2T 00-04, ZIP RST 50 2T 96-99, ZIP SP 50 2T 96-04, ZIP SP EURO 2.50 2T 06-13

RICAMBI

9933790	Petalo in carbonio 0,30 mm
---------	----------------------------



◀ **cod. 9937820** **RACING**

Valvola lamellare "TPR" black AM6/Derbi (spessore 0,30 mm)

APPLICABILITÀ

- APRILIA** CLASSIC 50 2T 92-99, EUROPA 50 2T 90-92, MX 50 2T 04-04, MX MOTARD 50 2T 95-03, PEGASO 50 2T 92-94, RS 50 2T 91-10, RS4 50 2T 11-13, RS4 REPLICA 50 2T 14-16, RX 50 2T 89-04, RX 50 2T 06-10, RX 50 2T 14-16, RX 3-5 MARCE 50 2T 91-94, RX ENDURO 50 2T 95-03, RX RACING 50 2T 03-06, SX 50 2T 06-16, SX LIMITED EDITION 50 2T 14-16, TUONO 50 2T 03-04
- BETA** RR 2T 50 EU4 50 2T 18-20, RR 50 RACING EU4 50 2T 18-20, RR ALU 50 2T 08-12, RR ENDURO 50 2T 06-17, RR MOTARD 50 2T 06-17
- CH HUSQVARNA** SM 50 2T 00-10, WR 50 2T 00-10, WSM 50 2T 00-10
- CMC** ENDURO 50 2T 11-11, MOTARD 50 2T 11-11
- DERBI** BULTACO LOBITO 50 2T 98-01, GPR 2T 50 2T 13-13, GPR 2T EU2 50 2T 09-10, GPR NUDE 50 2T 04-05, GPR NUDE & GPR NUDE TUNING 50 2T 06-08, GPR NUDE SPORT 50 2T 06-06, GPR R 50 2T 97-00, GPR R EU2 - GPR REPLICA EU2 50 2T 08-08, GPR RACING 50 2T 04-05, GPR RACING EU2 50 2T 06-06, GPR REPLICA 50 2T 99-01, GPR REPLICA & GPR R EU2 50 2T 06-06, GPR REPLICA 2T MALOSSI 50 2T 07-07, GPR REPLICA PESEK EU2 50 2T 07-07, GPR REPLICA RACING 50 2T 02-03, GPR REPLICA RACING EU2 50 2T 05-05, SENDA BLACK EDITION 50 2T 03-03, SENDA HYP DRD EVO EU2 50 2T 08-09, SENDA HYP DRD EVO LIMITED EDITION EU2 50 2T 08-08, SENDA R 50 2T 99-01, SENDA R DRD BLACK DEVIL 2A EDIZIONE 50 2T 03-03, SENDA R DRD EU1 EU1R 50 2T 02-02, SENDA R DRD PRO EU2 50 2T 05-11, SENDA R DRD RACING 50 2T 04-05, SENDA R DRD RACING EU2 50 2T 05-08, SENDA R DRD RACING LTD 50 2T 05-05, SENDA R DRD X-TREME 2T EU2 50 2T 14-15, SENDA R DRD X-TREME 2T EURO2 50 2T 10-12, SENDA R RACER 50 2T 03-03, SENDA R X-RACE 50 2T 04-05, SENDA R X-RACE 2T EU2 50 2T 10-10, SENDA R X-RACE EU2 50 2T 06-09, SENDA R X-TREME 50 2T 03-03, SENDA R X-TREME 50 2T 05-05, SENDA R X-TREME 2T EU2 50 2T 10-10, SENDA R X-TREME EU2 50 2T 04-08, SENDA SM 50 2T 00-01, SENDA SM DRD EDITION BLACK 50 2T 05-05, SENDA SM DRD EU1 EU1R 50 2T 02-03, SENDA SM DRD PRO EU2 50 2T 05-11, SENDA SM DRD PRO EU2 2VER 50 2T 05-08, SENDA SM DRD RACING 50 2T 04-05, SENDA SM DRD RACING EU2 50 2T 05-08, SENDA SM DRD RACING LTD 50 2T 05-05, SENDA SM DRD RACING LTD EU2 50 2T 07-07, SENDA SM DRD X-TREME 2T EU2 50 2T 14-15, SENDA SM DRD X-TREME 2T EU2 LIMITED ED 50 2T 14-15, SENDA SM X-RACE 50 2T 04-05, SENDA SM X-RACE 2T EU2 50 2T 10-10, SENDA SM X-RACE EU2 50 2T 06-09, SENDA SM X-RACE EU2 2VER 50 2T 07-09, SENDA SM X-TREME 50 2T 02-03, SENDA SM X-TREME 2T EU2 50 2T 10-10, SENDA SM X-TREME EU2 50 2T 04-08, SENDA SM X-TREME EU2 2A EDIZIONE 50 2T 05-05

FANTIC

- CABALLERO MOTARD 50 2T 06-10, CABALLERO MOTARD COMPETITION 50 2T 06-10, CABALLERO REGOLARITÀ 50 2T 06-10, CABALLERO REGOLARITÀ COMPETITION 50 2T 06-10, ENDURO COMPETITION EU4 50 2T 18-20, ENDURO PERFORMANCE EU4 50 2T 18-20, MOTARD COMPETITION EU4 50 2T 18-20, MOTARD PERFORMANCE EU4 50 2T 18-20

GILERA

- GSM 50 2T 01-01, RCR 50 2T 03-03, RCR 50 2T 06-07, RCR 50 2T 11-12, RCR (CHE-SYC) 50 2T 13-15, SMT 50 2T 03-17, SMT RACING 50 2T 11-12

HM

- BAJA, DERAPAGE BASIC 50 2T 10-11, CMC 50 2T 10-11, CRE BAJA RR, DERAPAGE RR 50 2T 07-11, CRE BAJA, DERAPAGE 50 2T 07-11, CRE SIX COMPETITION 50 2T 10-11, CRE SIX, BAJA, DERAPAGE 50 2T 95-06, CRE SIX, DERAPAGE COMPETITION 50 2T 07-09, DERAPAGE COMPETITION 50 2T 10-11

MALAGUTI

- CNK DRAGON 50 2T 05-07, FIFTY EVOLUTION 50 2T 90-93, XSM 50 2T 03-06, XSM POWER-UP 50 2T 07-10, XTM 50 2T 03-03, XTM 50 2T 06-06, XTM POWER-UP 50 2T 07-10

MBK

- X LIMIT 50 2T 03-04, X POWER 50 2T 03-04

MINARELLI

- MOTORE AM 3-4-5 50 2T 91-95, MOTORE AM 6 1° SERIE 50 2T 96-11, MOTORE AM 6 2° SERIE 50 2T 12-18

MOTORHISPANIA

- FURIA 50 2T 97-00, FURIA MAX 50 2T 10-12, RX 50 2T 09-12, RX R 50 2T 09-12

PEUGEOT

- SUPERMOTARD 50 2T 90-02, XP6 TRAIL S/AVV. ELETTRICO 50 2T 90-02, XR6 RACING CAT. C/AVV.ELETT. 50 2T 90-02

RIEJU

- MRT 50 2T 09-12, MRT 50 EU4 50 2T 18-20, MRT PRO 50 2T 09-12, MRT PRO EU4 50 2T 18-20, MRT PRO REPLICA EU4 50 2T 18-20, MRT PRO REPLICA SM EU4 50 2T 18-20, MRT PRO SM 50 2T 09-12, MRT PRO SM EU4 50 2T 18-20, MRT SM 50 2T 09-12, MRT SM EU4 50 2T 18-20, MRT TROPHY EU4 50 2T 18-20, MRX 50 2T 01-04, MRX PRO 50 2T 01-04, RR 50 2T 05-06, RS1 50 2T 98-01, RS2 MATRIX 50 2T 05-06, RS2 MATRIX PRO 50 2T 05-06, RS2 NAKED 50 2T 04-05, RS3 EU4 50 2T 18-20, RS3 NDK EU4 50 2T 18-20, SMX E.S./K.S. 50 2T 01-01, SMX PRO E.S./K.S. 50 2T 03-03, SPIKE 50 2T 98-01

SHERCO

- FACTORY SE-R EU4 50 2T 18-20, FACTORY SE-RS EU4 50 2T 18-20, FACTORY SILVER SM-R EU4 50 2T 18-20, FACTORY SILVER SM-RS EU4 50 2T 18-20, FACTORY SM-R EU4 50 2T 18-20, FACTORY SM-RS EU4 50 2T 18-20, HRD ENDURO 50 2T 09-13, HRD MOTARD 50 2T 09-13

VALENTI RACING

- RME 50 2T 15-17, SM 50 2T 15-17

YAMAHA

- DT R 50 2T 03-11, DT RSM 50 2T 03-05, DT X 50 2T 06-11, TZR 50 2T 03-08, TZR 50 2T 10-11, TZR RR 50 2T 05-05

RICAMBI

9933770	Petalo in carbonio 0,30 mm
---------	----------------------------

NOVITÀ



◀ cod. **9910780**
Variatore Peugeot con cinghia

APPLICABILITÀ

PEUGEOT BUXY 50 2T 90-02, BUXY RS 50 2T 90-02, SPEEDAKE 50 2T 90-02

RICAMBI

9910790	Cinghia Peugeot 755X18x30
9915530	Tasselli Di Traino Per Variatore Scooter Minarelli 50C

9915570	Sr. Masse Variatore Ø 15 Gr.7,5
---------	---------------------------------



◀ cod. **9931260**
Variotop TROPHY "TPR" con cinghia per motore scooter 50 cc Piaggio masse Ø 19

APPLICABILITÀ

PIAGGIO VESPA ET2 INIEZIONE 50 2T 97-00, VESPA ET4 50 4T 00-05, VESPA LX 2T 50 2T 05-13, VESPA LX 2T TOURING & 30KM 50 2T 10-13, VESPA LX 4T 50 4T 05-09, VESPA LX 4T 4V 50 4T-4V 09-13, VESPA LX 4T 4V TOURING 50 4T-4V 10-13, VESPA LXV 2T 50 2T 06-09, VESPA LXV 2T NAVY 50 2T 08-08, VESPA S 2T & COLLEGE 50 2T 07-12, VESPA S 4T 4V & COLLEGE 50 4T-4V 08-12, ZIP 2T 50 2T 08-13, ZIP 4T 50 4T 00-13, ZIP LC 50 2T 00-04, ZIP SP 50 2T 96-04, ZIP SP EURO 2 50 2T 06-13

RICAMBI

9919990	Masse variatore Ø 19x15,5 gr. 7
9922040	Cinghia di trasmissione
9930940	Puleggia anteriore mobile
9928400	Piattello portatasselli

9928410	Tasselli di traino
9923070	Distanziale

◀ cod. **9931300**
Variotop TROPHY "TPR" con cinghia per motore scooter 50 cc Piaggio masse Ø 19

APPLICABILITÀ

APRILIA MOJITO CUSTOM 2T MOTORE PIAGGIO 50 2T 04-10, SR MOTARD 50 2T 12-14, SR R 50 2T 04-09, SR R FACTORY CARBURATORE 50 2T 10-14, SR R FACTORY IE 50 2T 10-14, SR STREET CARBURATORE 50 2T 03-12

DERBI ATLANTIS 2T 50 2T 10-10, ATLANTIS 2T EU2 50 2T 07-09, ATLANTIS O2 50 2T 02-02, ATLANTIS O2 BULLET 50 2T 03-05, ATLANTIS O2 CITY 50 2T 04-06, ATLANTIS O2 RED BULLET 50 2T 03-03, ATLANTIS O2 TWO CHIC 50 2T 05-05, GP1 50 2T 01-03, GP1 EU 2 50 2T 05-05, GP1 OPEN EU2 50 2T 06-09, GP1 RACE EU2 50 2T 05-07

GILERA ICE 50 2T 01-05, RUNNER 50 2T 97-00, RUNNER PURE JET 50 2T-IE 02-07, RUNNER PURE JET 50 2T-IE 10-11, RUNNER SP 50 2T 02-04, STALKER 50 2T 97-11, STALKER NAKED 50 2T 08-08, STALKER SPECIAL EDITION 50 2T 07-08, STORM EURO 2 50 2T 07-07, TYPHOON XR 50 2T 00-00

PIAGGIO DIESIS 50 2T 01-01, NRG MC3 50 2T 01-04, NRG POWER DD 50 2T 05-17, NRG POWER DD SERIE SPECIALE 50 2T 07-12, NRG POWER DT 50 2T 06-15, NRG POWER DT SERIE SPECIALE 50 2T 07-08, NRG POWER PUREJET 50 2T-IE 04-11, NRG PUREJET 50 2T-IE 02-04, NRG PUREJET 50 2T-IE 10-10, TYPHOON 50 2T 01-11

RICAMBI

9919990	Masse variatore Ø 19x15,5 gr. 7
9922030	Cinghia di trasmissione
9930940	Puleggia anteriore mobile
9928400	Piattello portatasselli

9928410	Tasselli di traino
9923070	Distanziale



◀ cod. **9927610**

Variotop TROPHY "TPR" con molla di contrasto per Piaggio 50 cc con masse Ø 19

APPLICABILITÀ

APRILIA MOJITO CUSTOM 2T MOTORE PIAGGIO 50 2T 04-10, SCARABEO 2T EU2 MOTORE PIAGGIO 50 2T 10-12, SCARABEO 2T NET 50 2T 09-10, SCARABEO 4T 50 4T 02-06, SCARABEO 4T 4V 50 4T-4V 10-12, SCARABEO 4T 4V NET 50 4T-4V 09-09, SCARABEO 4T RESTYLING EU3 50 4T 06-09, SCARABEO QUATTRO 50 4T-4V 09-09, SCARABEO STREET 50 2T 05-06, SCARABEO STREET 2T RESTYLING 50 2T 06-09, SPORT CITY ONE 2T 50 2T 08-11, SPORT CITY ONE 4T 50 4T 08-10, SR MOTARD 50 2T 12-14, SR R 50 2T 04-09, SR R FACTORY CARBURATORE 50 2T 10-14, SR R FACTORY IE 50 2T 10-14, SR STREET CARBURATORE 50 2T 03-12

DERBI ATLANTIS 2T 50 2T 10-10, ATLANTIS 2T EU2 50 2T 07-09, ATLANTIS O2 50 2T 02-02, ATLANTIS O2 BULLET 50 2T 03-05, ATLANTIS O2 CITY 50 2T 04-06, ATLANTIS O2 RED BULLET 50 2T 03-03, ATLANTIS O2 TWO CHIC 50 2T 05-05, BOULEVARD 2T 50 2T 09-14, GP1 50 2T 01-03, GP1 EU 2 50 2T 05-05, GP1 OPEN EU2 50 2T 06-09, GP1 RACE EU2 50 2T 05-07, SONAR 2T 50 2T 09-09

GILERA DNA 50 2T 00-02, DNA 50 2T 05-07, DNA GP EXPERIENCE 50 2T 03-04, EASY MOVING 50 2T 95-96, ICE 50 2T 01-05, RUNNER 50 2T 97-00, RUNNER POGGIALI 50 2T 02-02, RUNNER PURE JET 50 2T-IE 02-07, RUNNER PURE JET 50 2T-IE 10-11, RUNNER SP 50 2T 02-07, RUNNER SP 50 2T 10-12, RUNNER SP SPECIAL EDITION 50 2T 07-07, RUNNER SP ST & SIMONCELLI 50 2T 08-09, STALKER 50 2T 97-11, STALKER NAKED 50 2T 08-08, STALKER SPECIAL EDITION 50 2T 07-08, STORM 50 2T 94-95, STORM EURO 2 50 2T 07-07, TYPHOON 50 2T 94-97, TYPHOON X 50 2T 98-99, TYPHOON XR 50 2T 00-00

ITALJET JET SET 50 2T 02-02, TORPEDO 50 4T 97-00, TORPEDO NEW 50 2T 00-01

MALAGUTI CENTRO EURO 2 50 4T 08-08, CIAK MASTER 4T 50 4T 05-06

PIAGGIO

DIESIS 50 2T 01-01, FLY 2T 50 2T 05-07, FLY 2T 50 2T 10-11, FLY 4T 50 4T 05-07, FLY 4T & 25-30 KM/H 50 4T 08-11, FLY 4T 4V 50 4T-4V 12-13, FLY 4T MOTORE CHN 50 4T 06-07, FREE 50 2T 92-94, FREE DELIVERY 50 2T 00-01, FREE FL 50 2T 95-02, LIBERTY 50 2T 97-05, LIBERTY 2T 50 2T 06-08, LIBERTY 2T PTT EU2 50 2T 04-05, LIBERTY 2T RST 50 2T 04-04, LIBERTY 2T SPORT 50 2T 06-08, LIBERTY 4T 50 4T 00-02, LIBERTY 4T 3V IE 50 4T-3V 15-17, LIBERTY 4T 3V IE E4 50 4T-3V 17-18, LIBERTY 4T DELIVERY - SINGLE 50 4T 10-14, LIBERTY 4T DELIVERY TNT 50 4T 09-09, LIBERTY 4T IGET CORPORATE E4 50 4T-3V 18-18, LIBERTY 4T PTT - DOUBLE - NEXIVE 50 4T 09-17, LIBERTY 4T RST 50 4T 04-04, LIBERTY 4T SPORT 50 4T 07-08, LIBERTY IGET 4T 3V IE E4 EMEA 50 4T-3V 17-18, LIBERTY MOC 2T & ELLE 50 2T 09-13, LIBERTY MOC 4T & ELLE 50 4T 09-16, NRG 50 2T 94-96, NRG EXTREME LC 50 2T 99-00, NRG MC3 50 2T 01-04, NRG POWER DD 50 2T 05-17, NRG POWER DD SERIE SPECIALE 50 2T 07-12, NRG POWER DT 50 2T 06-15, NRG POWER DT SERIE SPECIALE 50 2T 07-08, NRG POWER PUREJET 50 2T-IE 04-11, NRG PUREJET 50 2T-IE 02-04, NRG PUREJET 50 2T-IE 10-10, NRG RST MC2 50 2T 96-98, NTT 50 2T 95-96, QUARTZ 50 2T 92-96, SFERA 50 2T 91-93, SFERA MAQUILLAGE 2 50 2T 94-94, SFERA RST 50 2T 95-97, TYPHOON 50 2T 01-11, TYPHOON 2T E2 50 2T 10-12, TYPHOON 2T E3 CH 50 2T 11-11, VESPA ET2 50 2T 97-05, VESPA ET2 INIEZIONE 50 2T 97-00, VESPA ET4 50 4T 00-05, VESPA LX 2T 50 2T 05-13, VESPA LX 2T TOURING & 30KM 50 2T 10-13, VESPA LX 4T 50 4T 05-09, VESPA LX 4T 4V 50 4T-4V 09-13, VESPA LX 4T 4V TOURING 50 4T-4V 10-13, VESPA LXV 2T 50 2T 06-09, VESPA LXV 2T NAVY 50 2T 08-08, VESPA PRIMAVERA 4T 3V NOABS E4 50 4T-3V 17-18, VESPA S 2T & COLLEGE 50 2T 07-12, VESPA S 4T 4V & COLLEGE 50 4T-4V 08-12, VESPA SPRINT 4T 3V E4 50 4T-3V 17-18, ZIP 50 2T 92-93, ZIP 50 2T 95-96, ZIP 2T 50 2T 08-13, ZIP 4T 50 4T 00-13, ZIP BIMODALE 50 2T 94-97, ZIP FAST RIDER 50 2T 93-94, ZIP FAST RIDER RST 50 2T 96-97, ZIP LC 50 2T 00-04, ZIP RST 50 2T 96-99, ZIP SP 50 2T 96-04, ZIP SP EURO 2 50 2T 06-13

RICAMBI

9914450	Molle contrasto variatore
9919990	Masse variatore Ø 19X15,5 gr. 7
9930940	Puleggia anteriore mobile
9928400	Piattello portatasselli

9928410	Tasselli di traino
9923070	Distanziale

◀ cod. **9924900**

Variotop "TPR" con molla di contrasto per Keeway - CPI 50 cc

APPLICABILITÀ

BENELLI PEPE 50 2T 10-10, PEPE LX 50 2T 07-09, PEPE OLD 50 2T 07-09, PEPE OLD 50 2T 11-11, QUATRONONEX 50 2T 08-11

CPI ARAGON 50 2T 03-03, HUSSAR 50 2T 03-03, OLIVER 50 2T 03-03, POP CORN 50 2T 03-03

EXPLORER CRACKER 50 2T 03-03

KEEWAY ATV EC2 50 2T 06-06, ATV OFF ROAD 50 2T 07-07, F-ACT 50 2T 07-08, FLASH 50 2T 07-08, FOCUS 50 2T 06-06, GOCCIA 50 2T 09-09, HURRICANE 50 2T 06-08, MATRIX 50 2T 06-08, PIXEL EURO 2 50 2T 09-12, RY8 50 2T 08-08

MALAGUTI F10 AC WAP 50 2T 08-08, F12 R PHANTOM AC 50 2T 07-08

RICAMBI

9906140	Masse variatore Ø 15X12 gr. 5,6
9915530	Tasselli di traino
9924920	Boccola

9924930	Piattello portatasselli
9925410	Puleggia anteriore mobile
9925420	Serie rasamenti

◀ cod. **9926130**

Variotop "TPR" con molla di contrasto Yamaha - MBK 50 cc 4T

APPLICABILITÀ

MBK BOOSTER X IE 50 4T-3V 08-08, OVETTO 4T 50 4T-3V 09-11

YAMAHA GIGGLE 50 4T-3V 08-08, NEO'S 4 50 4T-3V 09-15

RICAMBI

9912820	Kit rasamenti
9915520	Masse variatore Ø 15X12 gr. 6,5
9915530	Tasselli di traino

9923130	Boccola
9926700	Cappellotto portatasselli



cod. 9931650

Variotop Trophy "TPR" con molla di contrasto per scooter 50 cc Minarelli/Yamaha masse Ø 16

APPLICABILITÀ

APRILIA AMICO 50 2T 94-94, AMICO 50 2T 96-98, AMICO GL/GLE 50 2T 93-95, AMICO LX/SPORT/CAT 50 2T 92-93, AREA 51 50 2T 98-00, GULLIVER 50 2T 95-98, GULLIVER LC 50 2T 96-98, RALLY 50 2T 95-03, RALLY LIQUID COOLED 50 2T 96-99, SCARABEO 50 2T 93-05, SONIC 50 2T 98-07, SONIC GP 50 2T 98-08, SR (ORIZZONTALE) 50 2T 94-96, SR (VERTICALE) 50 2T 93-93, SR LIQUID COOLED 50 2T 94-96, SR RACING 50 2T 97-99, SR STEALTH 50 2T 97-00, SR WWW 50 2T 97-01

ATALA CAROSELLO 50 2T 99-01

BENELLI 491 GT 50 2T 98-99, 491 NAKED 50 2T 02-02, 491 RACING 50 2T 98-99, 491 RR 50 2T 99-01, 491 SP 50 2T 99-99, 491 SPORT 50 2T 98-99, 491 ST 50 2T 99-01, K2 50 2T 98-01, K2 LIQUID COOLED 50 2T 98-01, PEPE 50 2T 99-01, PEPE LX 50 2T 03-04

BETA ARK 50 2T 96-08, ARK LC 50 2T 96-08, CHRONO 50 2T 95-96, EIKON 50 2T 99-03, QUADRA 50 2T 95-95, QUADRA 50 2T 99-01, TEMPO 50 2T 93-02, TEMPO 50 2T 95-95

ITALJET DRAGSTER 50 2T 98-02

KTM K50 50 2T 96-01

MACAL THUNDER 50 2T 95-96

MALAGUTI CENTRO SL 50 2T 94-98, CIAK 50 2T 99-01, CIAK EURO 2,2 50 2T 03-03, CIAK EURO2 50 2T 01-03, CIAK MASTER EURO 2 50 2T 06-06, F10 50 2T 92-00, F10 EURO 2 50 2T 02-06, F10 EURO 2,2 50 2T 03-04, F10 RESTYLING EURO 2 50 2T 06-06, F12 PHANTOM 50 2T 94-98, F12 PHANTOM EURO 2 50 2T 02-02, F12 PHANTOM EURO 2,2 50 2T 03-04, F12 PHANTOM LC 50 2T 94-98, F12 PHANTOM LC EURO 2,2 50 2T 03-04, F12 R PHANTOM LC 50 2T 07-10, F12 RESTYLING EURO 1 50 2T 99-02, F12 RESTYLING EURO 2 50 2T 06-06, F12 RESTYLING LC EURO 2 50 2T 06-06, F15 FIRE FOX 50 2T 96-98, F15 FIRE FOX AIR COOLED 50 2T 05-06, F15 FIRE FOX EURO 2 50 2T 02-06, F15 FIRE FOX EURO 2,2 50 2T 03-04, YESTERDAY 50 2T 97-00

MBK BOOSTER 50 2T 90-04, BOOSTER 50 2T 90-94, BOOSTER EURO 2 50 2T 04-04, BOOSTER NG 50 2T 95-03, BOOSTER ROCKET 50 2T 97-98, BOOSTER SPIRIT 50 2T 96-00, BOOSTER SPIRIT 50 2T 03-03, BOOSTER SPIRIT EURO2 50 2T 03-03, BOOSTER TRACK 50 2T 96-98, EVOLIS 50 2T 92-95, FIZZ 50 2T 94-95, FLIPPER 50 2T 98-04, FLIPPER EURO 2 50 2T 03-03, FORTE 50 2T 94-96, MACH G 50 2T 02-04, MACH G LC 50 2T 02-04, NITRO 50 2T 97-04, NITRO EURO 2 50 2T 03-03, OVETTO 50 2T 97-04, OVETTO EURO 2 50 2T 02-02, STUNT 50 2T 00-02

MOTRON SYNCRO 50 2T 98-00, THUNDER 50 2T 95-98

RIEJU FIRST 50 2T 95-98, WINDY 50 2T 95-98

YAMAHA AEROX 50 2T 97-02, AEROX 50 2T 04-16, AEROX EURO 2 50 2T 03-03, AEROX NAKED 50 2T 13-16, AEROX R 50 2T 99-00, AXIS 50 2T 95-96, BREEZE 50 2T 94-95, BW'S 50 2T 97-16, BW'S BUMP 50 2T 97-98, BW'S EASY 50 2T 13-13, BW'S NAKED 50 2T 03-04, BW'S NAKED 50 2T 09-16, BW'S NEXT GENERATION 50 2T 97-06, BW'S ORIGINAL 50 2T 99-01, BW'S ORIGINAL EURO 2 50 2T 03-03, JOG 50 2T 92-01, JOG R 50 2T 02-02, JOG R EURO2 50 2T 02-02, JOG R EURO2 50 2T 06-15, JOG R LC 50 2T 02-15, NEO'S 50 2T 97-02, NEO'S 50 2T 04-16, NEO'S EASY 50 2T 13-13, NEO'S EURO 2 50 2T 02-02, RS SPY 50 2T 95-98, SLIDER 50 2T 00-02, WHY 50 2T 98-05, WHY EURO 2 50 2T 03-05, ZEST 50 2T 95-92, ZUMA 50 2T 97-01

RICAMBI

9914370	Serie massette Ø 16 Gr. 7
9914470	Molla contrasto carico 26 kg
9915460	Dado con rondella conica
9915470	Scodellino dentato
9915480	Piastrina traino
9916790	Distanziale

9931660	Puleggia mobile anteriore
9928580	Cappellotto porta tasselli
9931350	Tasselli di traino
9931380	Boccola
9931360	Spessore Ø 13,2x22x1,8



cod. 9931670

Variotop Trophy "TPR" con cinghia scooter 50 cc Minarelli/Yamaha verticale/orizzontale lungo e F12 2000 - masse Ø 16

APPLICABILITÀ

APRILIA AMICO 50 2T 94-94, AMICO 50 2T 96-98, AMICO GL/GLE 50 2T 93-95, AMICO LX/SPORT/CAT 50 2T 92-93, AREA 51 50 2T 98-00, GULLIVER 50 2T 95-98, GULLIVER LC 50 2T 96-98, RALLY 50 2T 95-03, RALLY LIQUID COOLED 50 2T 96-99, SCARABEO 50 2T 93-05, SR (ORIZZONTALE) 50 2T 94-96, SR (VERTICALE) 50 2T 93-93, SR LIQUID COOLED 50 2T 94-96, SR RACING 50 2T 97-99, SR STEALTH 50 2T 97-00, SR WWW 50 2T 97-01

ATALA CAROSELLO 50 2T 99-01

BENELLI 491 GT 50 2T 98-99, 491 NAKED 50 2T 02-02, 491 RACING 50 2T 98-99, 491 RR 50 2T 99-01, 491 SP 50 2T 99-99, 491 SPORT 50 2T 98-99, 491 ST 50 2T 99-01, K2 50 2T 98-01, K2 LIQUID COOLED 50 2T 98-01, PEPE 50 2T 99-01, PEPE LX 50 2T 03-04

BETA ARK 50 2T 96-08, ARK LC 50 2T 96-08, CHRONO 50 2T 95-96, EIKON 50 2T 99-03, QUADRA 50 2T 95-95, QUADRA 50 2T 99-01, TEMPO 50 2T 93-02, TEMPO 50 2T 95-95

ITALJET DRAGSTER 50 2T 98-02

KTM K50 50 2T 96-01

MACAL THUNDER 50 2T 95-96

MALAGUTI CENTRO SL 50 2T 94-98, CIAK 50 2T 99-01, CIAK EURO 2,2 50 2T 03-03, CIAK EURO2 50 2T 01-03, CIAK MASTER EURO 2 50 2T 06-06, F12 PHANTOM 50 2T 94-98, F12 PHANTOM EURO 2 50 2T 02-02, F12 PHANTOM EURO 2,2 50 2T 03-04, F12 PHANTOM LC 50 2T 94-98, F12 PHANTOM LC EURO 2,2 50 2T 03-04, F12 R PHANTOM LC 50 2T 07-10, F12 RESTYLING EURO 1 50 2T 99-02, F12 RESTYLING EURO 2 50 2T 06-06, F12 RESTYLING LC EURO 2 50 2T 06-06, F15 FIRE FOX 50 2T 96-98, F15 FIRE FOX AIR COOLED 50 2T 05-06, F15 FIRE FOX EURO 2 50 2T 02-06, F15 FIRE FOX EURO 2,2 50 2T 03-04

MBK BOOSTER 50 2T 90-04, BOOSTER 50 2T 90-94, BOOSTER EURO 2 50 2T 04-04, BOOSTER NG 50 2T 95-03, BOOSTER ROCKET 50 2T 97-98, BOOSTER SPIRIT 50 2T 96-00, BOOSTER SPIRIT 50 2T 03-03, BOOSTER SPIRIT EURO2 50 2T 03-03, BOOSTER TRACK 50 2T 96-98, FLIPPER 50 2T 98-04, FLIPPER EURO 2 50 2T 03-03, MACH G 50 2T 02-04, MACH G LC 50 2T 02-04, NITRO 50 2T 97-04, NITRO EURO 2 50 2T 03-03, OVETTO 50 2T 97-04, OVETTO EURO 2 50 2T 02-02, STUNT 50 2T 00-02

MOTRON SYNCRO 50 2T 98-00, THUNDER 50 2T 95-98

RIEJU FIRST 50 2T 95-98, WINDY 50 2T 95-98

YAMAHA AEROX 50 2T 97-02, AEROX 50 2T 04-16, AEROX EURO 2 50 2T 03-03, AEROX NAKED 50 2T 13-16, AEROX R 50 2T 99-00, BW'S 50 2T 97-16, BW'S BUMP 50 2T 97-98, BW'S EASY 50 2T 13-13, BW'S NAKED 50 2T 03-04, BW'S NAKED 50 2T 09-16, BW'S NEXT GENERATION 50 2T 97-06, BW'S ORIGINAL 50 2T 99-01, BW'S ORIGINAL EURO 2 50 2T 03-03, JOG R 50 2T 02-02, JOG R EURO2 50 2T 02-02, JOG R EURO2 50 2T 06-15, JOG R LC 50 2T 02-15, NEO'S 50 2T 97-02, NEO'S 50 2T 04-16, NEO'S EASY 50 2T 13-13, NEO'S EURO 2 50 2T 02-02, RS SPY 50 2T 95-98, SLIDER 50 2T 00-02, WHY 50 2T 98-05, WHY EURO 2 50 2T 03-05, ZUMA 50 2T 97-01

RICAMBI

9907770	Cinghia racing
9914370	Serie massette Ø 16 Gr. 7
9915460	Dado con rondella conica
9915470	Scodellino dentato
9915480	Piastrina traino
9916790	Distanziale

9931660	Puleggia mobile anteriore
9928580	Cappellotto porta tasselli
9931350	Tasselli di traino
9931380	Boccola
9931360	Spessore Ø 13,2x22x1,8



◀ **cod. 9931690**
Variotop Trophy "TPR" con cinghia scooter 50 cc Minarelli/Yamaha orizzontale corto (f10)
masse Ø 16

APPLICABILITÀ

APRILIA SONIC 50 2T 98-07, SONIC GP 50 2T 98-08
MALAGUTI F10 50 2T 92-00, F10 EURO 2 50 2T 02-06, F10 EURO 2 2,3 50 2T 03-04, F10 RESTYLING EURO 2 50 2T 06-06, YESTERDAY 50 2T 97-00

MBK EVOLIS 50 2T 92-95, FIZZ 50 2T 94-95, FORTE 50 2T 94-96
YAMAHA AXIS 50 2T 95-96, BREEZE 50 2T 94-95, JOG 50 2T 92-01, ZEST 50 2T 95-92

RICAMBI

9907900	Cinghia racing
9914370	Serie massette Ø 16 Gr. 7
9915460	Dado con rondella conica
9915470	Scodellino dentato
9915480	Piastrina traino
9931660	Puleggia mobile anteriore

9928580	Cappellotto porta tasselli
9931350	Tasselli di traino
9931380	Boccola
9931360	Spessore Ø 13,2x22x1,8



◀ **cod. 9915540**
Piattello portatasselli inclinazione 67° per variatore Minarelli/Yamaha 50 cc

APPLICABILITÀ

APRILIA AMICO 50 2T 94-94, AMICO 50 2T 96-98, AMICO GL/GLE 50 2T 93-95, AMICO LX/SPORT/CAT 50 2T 92-93, AREA 51 50 2T 98-00, GULLIVER 50 2T 95-98, GULLIVER LC 50 2T 96-98, RALLY 50 2T 95-03, RALLY LIQUID COOLED 50 2T 96-99, SCARABEO 50 2T 93-05, SONIC 50 2T 98-07, SONIC GP 50 2T 98-08, SR (ORIZZONTALE) 50 2T 94-96, SR (VERTICALE) 50 2T 93-93, SR LIQUID COOLED 50 2T 94-96, SR RACING 50 2T 97-99, SR STEALTH 50 2T 97-00, SR WWW 50 2T 97-01

ATALA CAROSELLO 50 2T 99-01

BENELLI 491 GT 50 2T 98-99, 491 NAKED 50 2T 02-02, 491 RACING 50 2T 98-99, 491 RR 50 2T 99-01, 491 SP 50 2T 99-99, 491 SPORT 50 2T 98-99, 491 ST 50 2T 99-01, K2 50 2T 98-01, K2 LIQUID COOLED 50 2T 98-01, PEPE 50 2T 99-01, PEPE LX 50 2T 03-04

BETA ARK 50 2T 96-08, ARK LC 50 2T 96-08, CHRONO 50 2T 95-96, EIKON 50 2T 99-03, QUADRA 50 2T 95-95, QUADRA 50 2T 99-01, TEMPO 50 2T 93-02, TEMPO 50 2T 95-95

ITALJET DRAGSTER 50 2T 98-02

KTM K50 50 2T 96-01

MACAL THUNDER 50 2T 95-96

MALAGUTI CENTRO SL 50 2T 94-98, CIAK 50 2T 99-01, CIAK EURO 2 2,3 50 2T 03-03, CIAK EURO 2 50 2T 01-03, CIAK MASTER EURO 2 50 2T 06-06, F10 50 2T 92-00, F10 EURO 2 50 2T 02-06, F10 EURO 2 2,3 50 2T 03-04, F10 RESTYLING EURO 2 50 2T 06-06, F12 PHANTOM 50 2T 94-98, F12 PHANTOM EURO 2 50 2T 02-02, F12 PHANTOM EURO 2 2,3 50 2T 03-04, F12 PHANTOM LC 50 2T 94-98, F12 PHANTOM LC EURO 2 2,3 50 2T 03-04, F12 R PHANTOM LC 50 2T 07-10, F12 RESTYLING EURO 1 50 2T 99-02, F12 RESTYLING EURO 2 50 2T 06-06, F12 RESTYLING LC EURO 2 50 2T 06-06, F15 FIRE FOX 50 2T 96-98, F15 FIRE FOX AIR COOLED 50 2T 05-06, F15 FIRE FOX EURO 2 50 2T 02-06, F15 FIRE FOX EURO 2 2,3 50 2T 03-04, YESTERDAY 50 2T 97-00

MBK BOOSTER 50 2T 90-04, BOOSTER 50 2T 90-94, BOOSTER EURO 2 50 2T 04-04, BOOSTER NG 50 2T 95-03, BOOSTER ROCKET 50 2T 97-98, BOOSTER SPIRIT 50 2T 96-00, BOOSTER SPIRIT 50 2T 03-03, BOOSTER SPIRIT EURO 2 50 2T 03-03, BOOSTER TRACK 50 2T 96-98, EVOLIS 50 2T 92-95, FIZZ 50 2T 94-95, FLIPPER 50 2T 98-04, FLIPPER EURO 2 50 2T 03-03, FORTE 50 2T 94-96, MACH G 50 2T 02-04, MACH G LC 50 2T 02-04, NITRO 50 2T 97-04, NITRO EURO 2 50 2T 03-03, OVETTO 50 2T 97-04, OVETTO EURO 2 50 2T 02-02, STUNT 50 2T 00-02

MOTRON SYNCRO 50 2T 98-00, THUNDER 50 2T 95-98

RIEJU FIRST 50 2T 95-98, WINDY 50 2T 95-98

YAMAHA AEROX 50 2T 97-02, AEROX 50 2T 04-16, AEROX EURO 2 50 2T 03-03, AEROX NAKED 50 2T 13-16, AEROX R 50 2T 99-00, AXIS 50 2T 95-96, BREEZE 50 2T 94-95, BW'S 50 2T 97-16, BW'S BUMP 50 2T 97-98, BW'S EASY 50 2T 13-13, BW'S NAKED 50 2T 03-04, BW'S NAKED 50 2T 09-16, BW'S NEXT GENERATION 50 2T 97-06, BW'S ORIGINAL 50 2T 99-01, BW'S ORIGINAL EURO 2 50 2T 03-03, JOG 50 2T 92-01, JOG R 50 2T 02-02, JOG R EURO 2 50 2T 02-02, JOG R EURO 2 50 2T 06-15, JOG R LC 50 2T 02-15, NEO'S 50 2T 97-02, NEO'S 50 2T 04-16, NEO'S EASY 50 2T 13-13, NEO'S EURO 2 50 2T 02-02, RS SPY 50 2T 95-98, SLIDER 50 2T 00-02, WHY 50 2T 98-05, WHY EURO 2 50 2T 03-05, ZEST 50 2T 95-92, ZUMA 50 2T 97-01



◀ **cod. 9923250**
Variotop "TPR" Piaggio Beverly 400/500 cc

APPLICABILITÀ

APRILIA ATLANTIC 500 4T 01-04, ATLANTIC ARRECIFE 500 4T 05-08, ATLANTIC SPRINT 500 4T 05-08, SCARABEO 500 4T 03-06, SCARABEO LIGHT 500 4T 06-08

GILERA FUOCO 4T-4V IE E3 LT 500 4T 13-14, FUOCO IE EU3 500 4T 07-13, NEXUS 500 4T 03-05, NEXUS EU3 500 4T 06-08, NEXUS SP EU3 500 4T 06-07

MALAGUTI SPIDER MAX GT 500 4T 04-05, SPIDER MAX GT EU3 500 4T 06-06, SPIDER MAX RS 500 4T 08-08

PEUGEOT GEOPOLIS IE EU3 500 4T-4V 90-02, SATELIS EU3 500 4T 90-02

PIAGGIO BEVERLY 500 4T 02-06, BEVERLY CRUISER 500 4T 07-12, BEVERLY IE EU3 500 4T 06-08, MP3 LT BUSINESS ABS 500 4T 14-16, MP3 LT SPORT/BUSINESS 500 4T 11-13, MP3 RL SPORT-BUSINESS 500 4T 11-12, MP3 SPORT ABS 500 4T 14-16, X10 4T-4V IE EU3 500 4T 12-14, X9 500 4T 01-02, X9 EVOLUTION 500 4T 03-07, X9 EVOLUTION ABS 500 4T 06-07

RICAMBI

9923270	Boccola
9923280	Tasselli
9923290	Piattello portatasselli

9924530	Serie 8 masse variatore Ø 25x17 gr. 16
9924550	Serie 8 masse variatore Ø 25x17 gr. 17



◀ cod. **9923330**
Variotop "TPR" Yamaha Majesty 400 cc 2004-2008

APPLICABILITÀ

YAMAHA MAJESTY 400 4T 04-08, MAJESTY ABS 400 4T 07-08

RICAMBI

9923340	Boccola
9924610	Serie 8 masse variatore Ø 25x15 gr. 11

9924630	Serie 8 masse variatore Ø 25x15 gr. 12
---------	--



◀ cod. **9923410**
Variotop "TPR" Honda SH 125/150 cc fino al 2012

APPLICABILITÀ

HONDA @ [NES] 125 4T 00-06, BALLI 125 4T 96-01, DYLAN [SES] 125 4T 02-04, PANTHEON IE [FES] 125 4T-2V 03-05, PS I [PES] 125 4T 06-10, SH 125 4T-2V 01-04, SH IE SCOOOPY 125 4T-2V 05-12, SILVER WING [FES] 125 4T-2V 07-12, @ [NES] 150 4T 00-06, BALLI 150 4T 96-01, DYLAN [SES] 150 4T 02-04, PANTHEON IE [FES] 150 4T-2V 03-05, PS I [PES] 150 4T 06-10, SH 150 4T-2V 01-04, SH IE SCOOOPY 150 4T 05-12, SILVER WING [FES] 150 4T-2V 07-12

KEEWAY OUTLOOK 125 4T 07-08, OUTLOOK 150 4T 07-08

RICAMBI

9916650	Serie 6 masse variatore Ø 20x15 gr. 10
9916670	Serie 6 masse variatore Ø 20x15 gr. 11

9923440	Boccola
---------	---------



◀ cod. **9923460**
Variotop "TPR" Suzuki Burgman 125/150 cc

APPLICABILITÀ

SUZUKI EPICURO 125 4T 99-01, UH BURGMAN K2/K6 125 4T 02-06, UH BURGMAN K7/LO 125 4T 07-10, UX SIXTEEN K8/LO 125 4T 08-10, EPICURO 150 4T 99-01, UH BURGMAN K2/K6 150 4T 02-06, UX SIXTEEN K8/LO 150 4T 08-10

RICAMBI

9923480	Tasselli di traino
9923510	Serie 6 masse variatore Ø 20x17 gr. 10
9923520	Piattello portatasselli

9923540	Boccola
9923590	Serie 6 masse variatore Ø 20x17 gr. 9



◀ cod. **9923550**
Variotop "TPR" Yamaha Majesty 125/150/180 cc

APPLICABILITÀ

BENELLI VELVET 125 4T 99-01, VELVET 150 4T 99-01
ITALJET JUPITER 125 4T 01-02, MILLENIUM 125 4T 00-02, JUPITER 150 4T 01-02, MILLENIUM 150 4T 00-02
MALAGUTI MADISON 125 4T 99-01, MADISON R RESTYLING 125 4T 02-02, MADISON R RESTYLING EU2 125 4T 03-04, PHANTOM MAX 125 4T 03-03, MADISON T 150 4T 99-01

MBK DOODO 125 4T 00-00, SKYLINER 125 4T 98-02, SKYLINER E 125 4T 03-03, THUNDER 125 4T 01-02, DOODO 150 4T 01-02, SKYLINER 150 4T 00-02, THUNDER 150 4T 01-02, SKYLINER E 180 4T 03-03

YAMAHA MAJESTY 125 4T 98-00, MAJESTY (5NR1) 125 4T 01-01, MAJESTY (5NR8) 125 4T 02-02, MAJESTY E 125 4T 03-09, MAXSTER 125 4T 01-02, TEO'S 125 4T 00-00, MAJESTY 150 4T 00-00, MAJESTY (5NS1) 150 4T 01-01, MAJESTY (5NS6) 150 4T 02-02, MAXSTER 150 4T 01-02, TEO'S 150 4T 01-02, MAJESTY E 180 4T 03-06

RICAMBI

9923480	Tasselli di traino
9923510	Serie 6 masse variatore Ø 20x17 gr. 10
9923560	Boccola

9923570	Piattello portatasselli
9923590	Serie 6 masse variatore Ø 20x17 gr. 9



◀ **cod. 9923600**
Variotop "TPR" Piaggio Beverly 125 cc

APPLICABILITÀ

- APRILIA** ATLANTIC 125 4T 03-05, ATLANTIC ARRECIFE 125 4T 03-05, ATLANTIC EU3 125 4T 06-08, ATLANTIC EU3 125 4T 10-12, MOJITO 125 4T 03-08, SCARABEO 125 4T 03-06, SCARABEO EU3 125 4T 06-07, SCARABEO IE LIGHT 125 4T 09-12, SCARABEO LIGHT 125 4T 07-08, SPORT CITY 125 4T 04-06, SPORT CITY CUBE 125 4T 08-10, SPORT CITY EU3 125 4T 06-08, SPORT CITY ONE 4T EU3 125 4T 08-11, SPORT CITY STREET 125 4T 12-12, SR MAX 125 4T 11-14, SR MOTARD 125 4T-2V 12-14, MOJITO 150 4T 03-07, SCARABEO 150 4T 04-06, SCARABEO IE LIGHT 200 4T 11-12
- BENELLI** ADIVA 125 4T 01-02, ADIVA 150 4T 01-02
- DERBI** BOULEVARD 125 4T 02-04, GP1 EU 2 125 4T 06-06, RAMBLA 125 4T 08-09, BOULEVARD 150 4T 02-04
- GILERA** DNA 125 4T 01-01, NEXUS EU3 125 4T 07-08, NEXUS IE EU3 125 4T 08-10, RUNNER VX 125 4T 00-06, RUNNER 180 4T 00-01, RUNNER VXR 180 4T 00-01
- ITALJET** JET SET 125 4T 01-01, TORPEDO 125 4T 99-02, JET SET 150 4T 01-01, TORPEDO 150 4T 99-02
- MALAGUTI** MADISON 3 125 4T 06-09

PIAGGIO

- BEVERLY 125 4T 01-03, BEVERLY EU3 125 4T 07-08, BEVERLY EURO 3 MIC 125 4T 07-07, BEVERLY EURO 3 SPORT 125 4T 07-08, BEVERLY RST 125 4T 04-07, BEVERLY RST 4T 4V IE EU3 125 4T 10-15, BEVERLY TOURER EU3 125 4T 07-10, CARNABY 125 4T 07-10, FLY 125 4T 05-07, HEXAGON GTX 125 4T 00-00, LIBERTY 125 4T 98-02, LIBERTY RST 125 4T 04-05, MP3 125 4T 06-08, MP3 IBRIDO 125 4T 09-10, MP3 IE 125 4T 08-09, MP3 IE TOURING 125 4T 11-12, MP3 YOURBAN ERL 125 4T 11-13, SKYPYPER 4T 125 4T 00-02, SUPER HEXAGON GTX 12 125 4T 01-02, VESPA ET4 125 4T 96-02, VESPA GRANTURISMO 125 4T 03-07, VESPA GRANTURISMO EU3 125 4T 06-07, VESPA GTS 4T IE SUPER 125 4T 09-16, VESPA GTS EU3 125 4T 07-12, VESPA GTV 125 4T 06-08, VESPA GTV 4T NAVY EU3 125 4T 08-08, VESPA LX 125 4T 05-06, VESPA LX 4T EU3 TOURING 125 4T 10-11, VESPA LX 4T FL 125 4T 09-09, VESPA LX EU3 125 4T 06-08, VESPA LX EU3 IE 125 4T 09-11, VESPA LXV 4T EU3 125 4T 06-09, VESPA LXV IE 4T 125 4T 10-13, VESPA LXV NAVY EU3 125 4T 07-08, VESPA S 4T EU3 125 4T 07-08, VESPA S 4T IE & COLLEGE 125 4T 09-11, X-EVO 125 4T 07-16, X7 EU3 125 4T 08-08, X7 EVO IE EU3 125 4T 09-10, X8 125 4T 04-06, X8 PREMIUM EU2 125 4T 06-06, X8 PREMIUM EU3 125 4T 06-07, X9 125 4T 01-02, X9 EVOLUTION 125 4T 03-03, X9 EVOLUTION 125 4T 05-06, X9 EVOLUTION EU3 125 4T 07-07, ZIP 125 4T 00-02, FLY 150 4T 05-07, LIBERTY 150 4T 01-02, SKYPYPER 4T 150 4T 00-02, VESPA ET4 150 4T 99-02, VESPA LX 150 4T 05-06, VESPA LX 4T FL 150 4T 09-09, VESPA LX EU3 150 4T 06-08, VESPA LX EU3 IE 150 4T 09-11, VESPA LX TOURING 150 4T 10-12, VESPA S 4T 150 4T 08-09, VESPA S 4T IE & COLLEGE 150 4T 09-12, X8 STREET EU2 150 4T 06-08, SUPER HEXAGON GTX 12 180 4T 01-02, LIBERTY RST 200 4T 04-04

RENAULT

- FULLTIME 125 4T 02-03

RICAMBI

9923480	Tasselli di traino
9923590	Serie 6 masse variatore Ø 20x17 gr. 9
9923620	Serie 6 masse variatore Ø 20x17 gr. 14

9923630	Piattello portatasselli
9923640	Boccola



◀ **cod. 9923650**
Variotop "TPR" Piaggio Beverly 200/250 cc

APPLICABILITÀ

- APRILIA** Atlantic 200 200 4T 03-05, Atlantic Arrecife 200 200 4T -00, Scarabeo EU3 200 200 4T 06-07, Scarabeo Light 200 200 4T 07-08, Sportcity 200 200 4T 04-06, Sportcity 200 EU3 200 4T 06-08, Atlantic 250 EU3 250 4T 06-08, Atlantic Arrecife 250 250 4T -00, Scarabeo 250 250 4T 04-06, Scarabeo Light 250 250 4T 06-08, Sportcity 250 250 4T -00, Sportcity 250 EU3 250 4T 06-08, Sportcity Cube 250 250 4T 08-12, Atlantic 300 300 4T 10-11, SR MAX 300 300 4T 11-14, Scarabeo Light 300 300 4T 09-10, Sportcity Cube 300 300 4T 08-10, Sport City Street 300 300 4T-4V 12-12
- BENELLI** Adiva 250 EU2 250 4T -00
- DERBI** Boulevard 200 EU2 200 4T 05-06, GP1 250 250 4T 06-07, Rambla 250 EU3 2VER 250 4T 08-08
- GILERA** Runner VXR 200 200 4T 02-06, Nexus 250 EU3 250 4T 06-07, Nexus 300 EU3 300 4T 08-11
- MALAGUTI** Madison R 180 180 4T 01-02, Madison S Restyling 200 200 4T 02-02, Phantom Max 200 200 4T 03-03, Madison 3 250 250 4T 06-09, Madison RS 250 250 4T 04-04, Phantom Max 250 250 4T 04-04
- PEUGEOT** Geopolis 250 IE EU3 250 4T-4V -00, Satelis 250 EU3 250 4T -00

PIAGGIO

- Beverly 200 200 4T 01-03, Carnaby 200 200 4T 07-08, Liberty 200 200 4T 06-06, Liberty 200 4T Sport EU3 200 4T 06-07, Vespa GRANTURISMO 200 200 4T 03-07, Vespa GTS 200 EU3 200 4T -00, Vespa GTV 200 EU3 200 4T -00, X8 200 200 4T 04-07, X9 200 200 4T 02-03, Beverly 250 250 4T 06-07, Beverly 250 IE EU3 250 4T 06-08, Beverly RST 250 250 4T 04-05, Carnaby 250 250 4T 08-08, MP3 250 250 4T 06-08, MP3 250 LT 250 4T 08-09, MP3 250 MIC 250 4T 08-09, Vespa GT 60 250 EU3 250 4T 06-07, Vespa GTS 250 250 4T 05-16, Vespa GTS ABS 250 250 4T 05-12, Vespa GTV 250 250 4T 06-09, Vespa GTV 4T NAVY EU3 250 250 4T 07-07, X-Evo 250 250 4T 07-16, X7 250 EU3 250 4T 08-08, X8 250 EU3 250 4T 05-08, X9 Evolution 250 250 4T 04-04, X9 Evolution 250 250 4T 06-06, Beverly Tourer 300 EU3 300 4T 09-10, Carnaby Cruiser 300 300 4T 09-12, MP3 300 4T 4V IE LT Ibrido 300 4T 10-11, MP3 300 IE LT 300 4T 10-11, MP3 300 IE LT Touring 300 4T 11-13, MP3 300 IE LT/Sport 300 4T 11-14, MP3 300 IE MIC 300 4T 10-11, MP3 300 IE Touring 300 4T 11-12, MP3 300 Yourban ERL 300 4T 11-15, MP3 300 Yourban LT ERL 300 4T 11-12, Vespa GTS Super 300 4T 08-15, X7 Evo 300 IE EU3 300 4T 09-10

RICAMBI

9924450	Serie 6 masse variatore Ø 20x17 gr. 12
9923480	Tasselli di traino
9923620	Serie 6 masse variatore Ø 20x17 gr. 14

9923630	Piattello portatasselli
9923660	Boccola



◀ cod. **9923670**
Variotop "TPR" Kymco 250 cc

APPLICABILITÀ

KYMCO B&W 250 4T 00-00, GRAND DINK 250 4T 01-02, PEOPLE LC 250 4T 03-04, PEOPLE S 250 4T 06-06, PEOPLE S I 250 4T 07-07, X CITING 250 4T 05-05, X CITING I 250 4T 06-07, YUP 250 4T 03-03

RICAMBI

9923700	Serie 6 masse variatore Ø 23x18 gr. 20
9923710	Piattello portatasselli
9923720	Tasselli

9923740	Boccola
9923770	Serie 6 masse variatore Ø 23x18 gr. 18



◀ cod. **9923790**
Variotop "TPR" Suzuki AN Burgman 250 cc

APPLICABILITÀ

SUZUKI AN BURGMAN K1/K2 250 4T 01-02, AN BURGMAN K3/K6 250 4T 03-06, AN BURGMAN W/X/Y 250 4T 98-00

RICAMBI

9923720	Tasselli
9923810	Serie 6 masse variatore Ø 23x18 gr. 15
9923820	Cappello porta tasselli

9923830	Boccola
---------	---------



◀ cod. **9925020**
Variotop "TPR" Yamaha X-Max 125 cc

APPLICABILITÀ

MBK CITYLINER EU3 125 4T-4V 08-10, SKYCRUISER 125 4T-4V 07-07
YAMAHA X-CITY EU3 125 4T-4V 08-11, X-MAX R 125 4T-4V 06-16, X-MAX R ABS 125 4T-4V 11-11, X-MAX RA ABS 125 4T-4V 13-16

RICAMBI

9918060	Serie 8 masse variatore Ø 20x12 gr. 12
---------	--

9925270	Boccola
---------	---------



◀ cod. **9926010**
Variotop "TPR" Suzuki Burgman 400 cc K7

APPLICABILITÀ

9926010 AN Burgman 400 K7/LO 400 4T 07-10

RICAMBI

9922340	Serie 8 masse variatore Ø 26x12,9 gr. 16
9927310	Serie 8 masse variatore Ø 26x12,9 gr. 14

9923850	Serie rasamenti
9926030	Boccola



◀ cod. **9926040**
Variotop "TPR" Honda SH 300 cc

APPLICABILITÀ

HONDA SH IE SCOOPIY 300 4T-4V 07-19

RICAMBI

9923800	Serie 6 masse variatore Ø 23x18 gr. 15
---------	--



◀ **cod. 9927130**
Variotop "TPR" Yamaha T-Max 500 cc / 530 cc / 560 cc

APPLICABILITÀ

YAMAHA T-MAX 4BS 500 4T 09-11, T-MAX 4BS ABS 500 4T 08-11, T-MAX 5GJ 500 4T 01-03, T-MAX 5VU 500 4T 04-08, T-MAX 5VU ABS 500 4T 05-07, T-MAX 5VU BLACK MAX 500 4T 06-06, T-MAX 5VU BLACK MAX - NIGHT MAX 500 4T 07-07, T-MAX 59C 530 4T 12-16, T-MAX 59C ABS 530 4T 12-16, T-MAX 59C SP 530 4T 15-15, T-MAX 59C SP ABS 530 4T 15-16

RICAMBI

9922090	Boccola
9922150	Serie masse Ø 25x15 gr.15
9922170	Serie masse Ø 25x15 gr.16

9926840	Serie rasamenti
9927140	Cappello porta tasselli
9927150	Tasselli di traino



◀ **cod. 9927830**
Variotop "TPR" Kymco Agility 125 cc

APPLICABILITÀ

KYMCO AGILITY 125 4T 06-06, AGILITY R16 125 4T 08-09, AGILITY RS 125 4T 09-09, MOVIE EU3 125 4T 06-07, PEOPLE 125 4T 99-00, PEOPLE EU3 125 4T 07-08, PEOPLE S 125 4T 05-05, SUPER 8 125 4T 08-09, VIVIO 125 4T 00-00, AGILITY 150 4T 06-08, AGILITY R16 150 4T 08-09, PEOPLE 150 4T 99-00, VIVIO 150 4T 00-00, AGILITY R16 200 4T 12-12, AGILITY R16 200 4T 10-10, LIKE IE 200 4T 09-09, LIKE LX 200 4T 12-12

MALAGUTI CIAK MASTER 125 4T 04-04, CIAK MASTER 150 4T 04-04, CIAK MASTER EURO 2 200 4T 06-06

RICAMBI

9922570	Serie 6 masse variatore Ø 20x17 gr. 13,0
9923480	Tasselli di traino

9927840	Boccola
9927860	Cappello porta tasselli

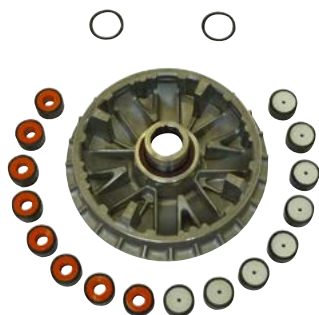

◀ **cod. 9930360**
Variotop "TPR" Yamaha Majesty 400 cc X-Max 400 cc 2009

APPLICABILITÀ

YAMAHA MAJESTY 400 4T 09-11, MAJESTY ABS 400 4T 09-11, X-MAX 400 4T-4V 13-16, X-MAX ABS 400 4T-4V 14-17, X-MAX IRONMAX ABS 400 4T-4V 16-16, X-MAX MOMODESIGN 400 4T-4V 14-14, X-MAX MOMODESIGN ABS 400 4T-4V 14-14, X-MAX RA 400 4T-4V 18-18

RICAMBI

9922090	Boccola
9922170	Serie masse Ø 25x15 gr.16

9924650	Serie masse Ø 25x15 gr.13
9926840	Serie rasamenti



◀ **cod. 9931790**
Variotop "TPR" Yamaha Majesty 250 cc X-Max 250 cc

APPLICABILITÀ

APRILIA LEONARDO 250 4T 99-04, LEONARDO ST 250 4T 01-01
BENELLI VELVET 250 4T 99-03
ITALJET JUPITER 250 4T 00-02
MALAGUTI MADISON S 250 4T 99-01, PASSWORD 250 4T 05-06, PASSWORD EU3 250 4T 07-08

MBK SKYLINER 250 4T 00-03, SKYLINER ABS 250 4T 03-03, KILIBRE 300 4T 03-06
YAMAHA MAJESTY 250 4T 96-03, MAJESTY ABS 250 4T 03-03, MAJESTY DX 250 4T 98-99, X-CITY 250 4T 07-15, X-MAX 250 4T 05-16, X-MAX ABS 250 4T 11-12, X-MAX ABS 250 4T 14-15, X-MAX BLACK 250 4T 09-09, X-MAX SPORT 250 4T 11-12, VERSITY 300 4T 03-06

RICAMBI

9918060	Serie Masse Ø 20X12 Gr.12
9918310	Serie Masse Ø 20X12 Gr.10
9923320	Boccola

AA00852	Tasselli Di Traino
PL04066	Piattello Porta Tasselli



◀ cod. **9932860**
Variotop "TPR" Kymco Xciting 400 cc

APPLICABILITÀ

KYMCO X CITING I 400 4T 15-15, X CITING I ABS 400 4T 14-15, XCITING I 400 4T 13-13

RICAMBI

9927140	Cappello porta tasselli
9927150	Tasselli di traino

9924590	Serie masse Ø 25x15 gr. 10
9926840	Serie Rasamenti



◀ cod. **9934100**
Variotop "TPR" BMW C 650 Sport 2016, C 650 GT 2016

APPLICABILITÀ

BMW BMW C 650 GT 2016 [K19] 650 4T 16-16, BMW C 650 SPORT 2016 [K18] 650 4T 16-16

RICAMBI

9927150	tasselli di traino
9926840	serie rasamenti



◀ cod. **9937600**
Variotop "TPR" Yamaha T-MAX 530 2017 / 560 2020

APPLICABILITÀ

YAMAHA XP530-A T-MAX SX 530 4T 17-19, XP530D-A T-MAX DX 530 4T 17-19, XP530E-A T-MAX 530 4T 17-18

RICAMBI

9922090	Boccola
9922130	Serie masse Ø 25x15 gr. 14
9922170	Serie masse Ø 25x15 gr. 16

9926840	Serie rasamenti
9927140	Cappello porta tasselli
9927150	Tasselli di traino



◀ cod. **9937610**
Variotop "TPR" Kymco Agility 50 cc 4T

APPLICABILITÀ

KYMCO AGILITY 4T CARRY 50 4T 11-11, AGILITY 4T R10 50 4T 06-08, AGILITY 4T R12 50 4T 07-08, AGILITY 4T R16 PLUS EURO4 50 4T 19-19, AGILITY CARRY 4T EURO4 50 4T 19-19, AGILITY PLUS 4T 50 4T 14-14, AGILITY R12 50 4T 05-05, AGILITY R12 ECS 50 4T 16-16, AGILITY R16 50 4T 08-09, AGILITY R16 50 4T 12-12, AGILITY RS 50 4T 09-09, DINK 50 4T 50 4T 07-07, FILLY 50 4T 98-00, FILLY LX 50 4T 01-02, LIKE 50 4T 09-09, LIKE EURO4 4T 50 4T 18-18, PEOPLE S 4T 50 4T 06-08, SENTO 50 4T 08-08, SUPER 8 4T 50 4T 07-07, SUPER 8 4T 50 4T 09-09, VITALITY 4T 50 4T 04-04

MALAGUTI DVD 50 4T 10-10

SYM SYMPLY EURO 2 50 4T 07-08

RICAMBI

9913150	Tasselli di traino
9920070	Serie Masse Ø 16x13 gr. 9.2

9913100	Serie Rasamenti
---------	-----------------



spare parts



◀ cod. **CA00001**
Centralina accensione Vespa 50 PK

RIFERIMENTO ORIGINALE
Piaggio 610324M

APPLICABILITÀ
PIAGGIO CIAO EU1 50 2T 99-01, CIAO EU2 50 2T 02-04, CIAO MIXTEEN 50 2T 96-01, CIAO TRE 50 2T 71-99, SI 50 2T 79-88, SI FL2 50 2T 91-97, SI MIX 50 2T 96-99, VESPA PK 50 2T 82-84, VESPA PK XL 50 2T 85-88, VESPA PK XL RUSH 50 2T 88-89



◀ cod. **CA00002**
Centralina accensione Vespa PX 125-150-200; ET3-PK 125

RIFERIMENTO ORIGINALE
Piaggio 244128

APPLICABILITÀ
PIAGGIO APE 50 2T 09-11, APE FL - FL2 50 2T 89-95, APE FL3 EUROPA 50 2T 96-99, APE MIX 2T 50 2T 98-08, APE RST MIX 50 2T 99-03, APE TM P 50 2T 85-89, VESPA FL 50 2T 90-90, VESPA FL2 AUTOMATICA 50 2T 90-91, VESPA FL2 HP 50 2T 91-97, VESPA N 50 2T 89-90, VESPA PK AUTOMATICA 50 2T 84-89, VESPA PK XL PLURIMATIC 50 2T 85-90, VESPA SPECIAL-L R 50 2T 67-82, COSA 2 125 2T 91-97, COSA CL, CLX 125 2T 88-91, VESPA ET3 125 2T 76-83, VESPA FL 125 2T 89-90, VESPA PK 125 2T 82-84, VESPA PK XL 125 2T 86-89, VESPA PRIMAVERA 125 2T 67-83, VESPA PX 125 2T 98-01, VESPA PX 125 2T 11-16, VESPA PX 30 ANNI 125 2T 07-08, VESPA PX E ARCOBALENO 125 2T 81-97, VESPA PX EU2 125 2T 01-07, VESPA PX T5 125 2T 85-89, COSA 2 150 2T 91-97, COSA CL, CLX 150 2T 88-91, VESPA PX 150 2T 98-01, VESPA PX 150 2T 11-16, VESPA PX E ARCOBALENO 150 2T 81-97, VESPA PX 200 2T 98-01, VESPA PX E ARCOBALENO 200 2T 81-97

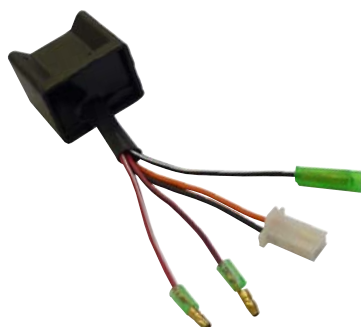

◀ cod. **CA00003**
Centralina accensione per Booster - Nitro

RIFERIMENTO ORIGINALE
Yamaha 3KJH55400000

APPLICABILITÀ
MBK BOOSTER 50 2T 90-04, BOOSTER 50 2T 90-94, BOOSTER NG 50 2T 95-03, BOOSTER ROCKET 50 2T 97-98, BOOSTER SPIRIT 50 2T 96-00, BOOSTER TRACK 50 2T 96-98, FLIPPER 50 2T 98-04, FORTE 50 2T 94-96, NITRO 50 2T 97-04, OVETTO 50 2T 97-04
YAMAHA AEROX 50 2T 97-02, AEROX 50 2T 04-16, AEROX NAKED 50 2T 13-16, AEROX R 50 2T 99-00, AXIS 50 2T 95-96, BW'S 50 2T 97-04, BW'S BUMP 50 2T 97-98, BW'S NAKED 50 2T 03-03, BW'S NEXT GENERATION 50 2T 97-02, BW'S ORIGINAL 50 2T 99-01, NEO'S 50 2T 97-02, RS SPY 50 2T 95-98, SLIDER 50 2T 00-02, WHY 50 2T 98-05



◀ cod. **CA00004**
Centralina accensione per People 50 E2 2T - People S 50 2T

RIFERIMENTO ORIGINALE
Kymco 00169303

APPLICABILITÀ
KYMCO MXU 50 2T 06-07, MXU SR 50 2T 06-06, PEOPLE 50 2T 99-04, PEOPLE EURO 2 50 2T 03-03, PEOPLE EURO 2 50 2T 08-08, PEOPLE EURO 2 50 2T 11-11, PEOPLE S 50 2T 05-08



◀ cod. **CA00005**
Centralina accensione per Piaggio Sfera - Zip - Liberty'01 - Gilera Typhon

RIFERIMENTO ORIGINALE
Piaggio 638678

APPLICABILITÀ
GILERA EASY MOVING 50 2T 95-96, RUNNER 50 2T 97-00, STALKER 50 2T 97-04, STORM 50 2T 94-95, TYPHOON 50 2T 94-97, TYPHOON X 50 2T 98-99, TYPHOON XR 50 2T 00-00
PIAGGIO FREE 50 2T 92-94, FREE DELIVERY 50 2T 00-01, FREE FL 50 2T 95-02, LIBERTY 50 2T 97-05, LIBERTY 2T PTT EU2 50 2T 04-05, NRG 50 2T 94-96, NRG EXTREME LC 50 2T 99-00, NRG MC3 50 2T 01-04, NRG RST MC2 50 2T 96-98, NTT 50 2T 95-96, QUARTZ 50 2T 92-96, SFERA 50 2T 91-93, SFERA MAQUILLAGE 2 50 2T 94-94, SFERA RST 50 2T 95-97, VESPA ET2 50 2T 97-05, ZIP 50 2T 92-93, ZIP 50 2T 95-96, ZIP BIMODALE 50 2T 94-97, ZIP FAST RIDER 50 2T 93-94, ZIP FAST RIDER RST 50 2T 96-97, ZIP RST 50 2T 96-99, ZIP SP 50 2T 96-00



◀ cod. **CA00006**
Centralina accensione per Kymco Agility 4T R10/R12

RIFERIMENTO ORIGINALE
Kymco 00169187

APPLICABILITÀ
KYMCO AGILITY 4T CARRY 50 4T 11-11, AGILITY 4T R10 50 4T 06-08, AGILITY 4T R12 50 4T 07-08, AGILITY R12 50 4T 05-05, VITALITY 4T 50 4T 04-04



◀ cod. **CA00007**
Centralina accensione per Kymco Agility 4T R16

RIFERIMENTO ORIGINALE

Kymco	00130005
-------	----------

APPLICABILITÀ

KYMCO AGILITY R16 50 4T 08-09, AGILITY R16 50 4T 12-12, AGILITY RS 50 4T 09-09, LIKE 50 4T 09-09, SUPER 8 4T 50 4T 07-07, SUPER 8 4T 50 4T 09-09



◀ cod. **CA00008**
Centralina accensione per Piaggio Zip 50 4t '00-'05

RIFERIMENTO ORIGINALE

Piaggio	639978
---------	--------

APPLICABILITÀ

APRILIA SCARABEO 4T 50 4T 02-06, SCARABEO 4T RESTYLING EU3 50 4T 06-09
DERBI ATLANTIS 4T 50 4T 04-06

PIAGGIO FLY 4T 50 4T 05-07, FLY 4T & 25-30 KM/H 50 4T 08-11, FLY 4T 2V 50 4T 13-15, FLY 4T MOTORE CHN 50 4T 06-07, LIBERTY 4T 50 4T 00-02, LIBERTY 4T 50 4T 05-08, LIBERTY 4T DELIVERY - SINGLE 50 4T 10-14, LIBERTY 4T DELIVERY TNT 50 4T 09-09, LIBERTY 4T PTT (DEU) 50 4T 07-12, LIBERTY 4T PTT - DOUBLE - NEXIVE 50 4T 09-17, LIBERTY 4T RST 50 4T 04-04, LIBERTY 4T SPORT 50 4T 06-08, LIBERTY MOC 4T & ELLE 50 4T 09-16, VESPA ET4 50 4T 00-05, VESPA LX 4T 50 4T 05-09, ZIP 4T 50 4T 00-05

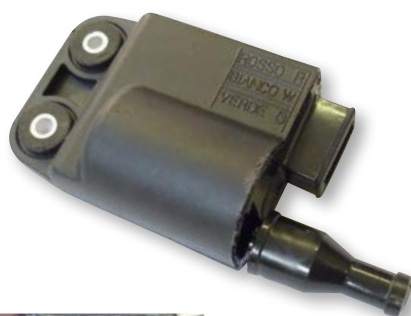

◀ cod. **CA00009**
Centralina Accensione Piaggio Liberty 50 cc 2T

RIFERIMENTO ORIGINALE

Piaggio	58095R
---------	--------

APPLICABILITÀ

APRILIA MOJITO CUSTOM 2T MOTORE PIAGGIO 50 2T 04-10, SCARABEO 2T EU2 MOTORE PIAGGIO 50 2T 10-12, SCARABEO 2T NET 50 2T 09-10, SCARABEO STREET 50 2T 05-06, SCARABEO STREET 2T RESTYLING 50 2T 06-09, SPORT CITY ONE 2T 50 2T 08-11, SR CARBURATORE 50 2T 14-14, SR MOTARD 50 2T 12-14, SR R 50 2T 04-09, SR R FACTORY CARBURATORE 50 2T 10-14, SR STREET CARBURATORE 50 2T 03-12
DERBI BOULEVARD 2T 50 2T 09-14, VARIANT SPORT 2T 50 2T 12-12
GILERA DNA 50 2T 00-02, DNA 50 2T 05-07, DNA GP EXPERIENCE 50 2T 03-04, ICE 50 2T 01-05, RUNNER POGGIALI 50 2T 02-02, RUNNER SP 50 2T 02-07, RUNNER SP 50 2T 10-12, RUNNER SP SPECIAL EDITION 50 2T 07-07, RUNNER SP ST & SIMONCELLI 50 2T 08-09, STALKER 50 2T 05-11, STALKER NAKED 50 2T 08-08, STALKER SPECIAL EDITION 50 2T 07-08, STORM EURO 2 50 2T 07-07

PIAGGIO DIESIS 50 2T 01-01, FLY 2T 50 2T 05-07, FLY 2T 50 2T 10-11, LIBERTY 2T 50 2T 06-08, LIBERTY 2T SPORT 50 2T 06-06, LIBERTY MOC 2T & ELLE 50 2T 09-13, NRG POWER DD 50 2T 05-17, NRG POWER DD SERIE SPECIALE 50 2T 07-12, NRG POWER DT 50 2T 06-15, NRG POWER DT SERIE SPECIALE 50 2T 07-08, TYPHOON 50 2T 01-11, TYPHOON 2T E2 50 2T 10-12, TYPHOON 2T E3 CH 50 2T 11-11, VESPA LX 2T 50 2T 05-08, VESPA LXV 2T 50 2T 06-09, VESPA LXV 2T NAVY 50 2T 08-08, VESPA S 2T & COLLEGE 50 2T 07-12, ZIP 2T 50 2T 08-13, ZIP LC 50 2T 00-04, ZIP SP 50 2T 01-04, ZIP SP EURO 2 50 2T 06-13

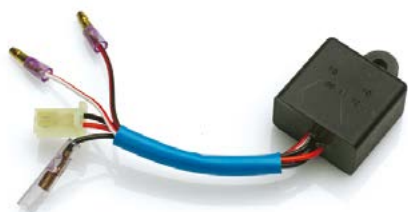

◀ cod. **CD00001**
Centralina scooter 50 cc Minarelli/Yamaha con volano giapponese 8 poli

RIFERIMENTO ORIGINALE

Ducati	434145000
--------	-----------



◀ cod. **CD00002**
Centralina per Minarelli AM6 con volano Ducati

RIFERIMENTO ORIGINALE

Ducati	432399010
--------	-----------



◀ cod. **IM07005**
Albero motore Vespa 50 S normale (cono 19 mm)

RIFERIMENTO ORIGINALE

PIAGGIO	1232946
---------	---------

RICAMBIO

IM07024	BIELLA	AA00856	GABBIA
---------	--------	---------	--------



◀ cod. **IM07006**
Albero Motore Piaggio Vespa 50 S Anticipato (Cono 19 Mm)

APPLICABILITÀ

PIAGGIO VESPA PK 50 2T 82-84, VESPA SPECIAL-L-R 50 2T 67-82

RICAMBIO

IM07024	BIELLA	AA00856	GABBIA
---------	--------	---------	--------



◀ cod. **IM07007**
Albero motore Vespa 50 PK-XL Normale (cono 20 mm)

RIFERIMENTO ORIGINALE

PIAGGIO	2245875	PIAGGIO	8462675
---------	---------	---------	---------

RICAMBIO

IM07024	BIELLA	AA00856	GABBIA
---------	--------	---------	--------



◀ cod. **IM07008**
Albero motore Piaggio Vespa 50 PK-XL Anticipato (cono 20 mm)

APPLICABILITÀ

PIAGGIO APE 50 2T 09-17, APE EU4 50 2T 18-18, APE FL - FL2 50 2T 89-95, APE FL3 EUROPA 50 2T 96-99, APE MIX 2T 50 2T 98-08, APE RST MIX 50 2T 99-03, APE TM P 50 2T 85-89, VESPA FL 50 2T 90-90, VESPA N 50 2T 89-90, VESPA PK 50 2T 82-84, VESPA PK XL 50 2T 85-88, VESPA PK XL RUSH 50 2T 88-89

RICAMBIO

IM07024	BIELLA	AA00856	GABBIA
---------	--------	---------	--------



◀ cod. **IM07013**
Albero motore per scooter 50 cc Minarelli/Yamaha verticale

RIFERIMENTO ORIGINALE

MBK	3VLE14001000
MBK	5WWE14000200

YAMAHA	3VLE14001000
YAMAHA	5WWE14000200

RICAMBIO

IM07032	BIELLA
---------	--------

AA00765	GABBIA
---------	--------



◀ cod. **IM07014**
Albero motore per scooter 50 cc Minarelli/Yamaha orizzontale

RIFERIMENTO ORIGINALE

Mbk	5RNE14001100
-----	--------------

Yamaha	5RNE14001100
--------	--------------

RICAMBIO

IM07032	BIELLA
---------	--------

AA00765	GABBIA
---------	--------



◀ cod. **IM07015**
Albero motore per scooter 50 cc Piaggio/Gilera

RIFERIMENTO ORIGINALE

Piaggio	4316255
Aprilia	4316255

Gilera	4316255
Derbi	4316255

RICAMBIO

IM07031	BIELLA
---------	--------

AA00777	GABBIA
---------	--------



◀ cod. **IM07016**
Albero motore per scooter 50 cc Peugeot Buxy

RIFERIMENTO ORIGINALE

Peugeot	768174
---------	--------

RICAMBIO

AA00766	GABBIA
---------	--------



◀ cod. **IM07017**
Albero motore completo per motore Minarelli AM 345/6 50cc

RICAMBI

IM07036	BIELLA
IM07033	BIELLA

AA00766	GABBIA
---------	--------

◀ cod. **IM07018**
Albero motore F12 Phantom H₂O versione dal 2000

RIFERIMENTO ORIGINALE

Malaguti	77116200
----------	----------

RICAMBIO

AA00765	GABBIA
---------	--------

APPLICABILITÀ

MALAGUTI F12 PHANTOM EURO 2 50 2T 02-02, F12 PHANTOM EURO 2 2,3 50 2T 03-04, F12 PHANTOM LC EURO 2 2,3 50 2T 03-04, F12 RESTYLING EURO 1 50 2T 99-02, F12 RESTYLING EURO 2 50 2T 06-06, F12 RESTYLING LC EURO 2 50 2T 06-06



◀ cod. **IM07040**
Albero motore Derbi Senda 50 cc

RIFERIMENTO ORIGINALE

DERBI	00H02506141
-------	-------------

DERBI	00H02508141
-------	-------------

RICAMBIO

AA00766	GABBIA
---------	--------



◀ cod. **IM07044**
Albero motore per 50 cc Aprilia D. Tech 2T IE

RIFERIMENTO ORIGINALE

Aprilia	AP1BFA000699
---------	--------------



◀ cod. **IM07058**
Albero motore completo di cuscinetti e paraoli per motori scooter 50 cc
Minarelli/Yamaha tipo verticale

RICAMBIO

AA00765	GABBIA
---------	--------



◀ cod. **IM07059**
Albero motore completo di cuscinetti e paraoli per motori scooter 50 cc
Minarelli/Yamaha tipo orizzontale

RICAMBIO

AA00765	GABBIA
---------	--------



◀ cod. **IM07060**
Albero motore completo di cuscinetti e paraoli per Piaggio/Gilera

RICAMBIO

AA00777	GABBIA
---------	--------



◀ cod. **IM07061**
Albero motore completo di cuscinetti e paraoli per motori scooter 50 cc Peugeot

RICAMBIO

AA00766	GABBIA
---------	--------



◀ cod. **IM07062**
Albero motore completo di cuscinetti e paraoli per AM345/ AM6

RICAMBIO

AA00766	GABBIA
IM07033	BIELLA

IM07036	BIELLA
KK01001	KIT CUSCINETTI E PARAOLI BANCO



◀ cod. **IM07063**
Albero motore completo di cuscinetti e paraoli per Derbi Senda 50 cc

RICAMBIO

AA00766	GABBIA
---------	--------

RIFERIMENTO ORIGINALE

DERBI	00H02506141
-------	-------------

DERBI	00H02508141
-------	-------------



◀ cod. **IM07064**
Albero motore scooter Piaggio 50 cc Purejet

RIFERIMENTO ORIGINALE

GILERA	8269405
--------	---------

PIAGGIO	8269405
---------	---------

RICAMBIO

AA00777	GABBIA
---------	--------



◀ **cod. IM07065**
Albero motore scooter 50 cc Keeway/CPI

RIFERIMENTO ORIGINALE

Keeway	208100022000
--------	--------------

Malaguti	59012200
----------	----------

APPLICABILITÀ

BENELLI	Pepe 50 2T 10-10, Pepe LX 50 2T 07-09, Pepe Old 50 2T 07-09, Pepe Old 50 2T 11-11, Quattronex 50 2T 08-11
CPI	Aragon 50 2T 03-03, Hussar 50 2T 03-03, Oliver 50 2T 03-03, Pop Corn 50 2T 03-03
EXPLORER	Cracker 50 2T 03-03

KEEWAY	ATV 50 EC2 50 2T 06-06, ATV OFF ROAD 50 2T 07-07, F-Act 50 2T 07-08, Flash 50 2T 07-08, Focus 50 2T 06-06, Goccia 50 2T 09-09, Hurricane 50 2T 06-08, Matrix 50 2T 06-08, Pixel Euro 2 50 2T -00, RY8 50 2T 08-08
MALAGUTI	F10 Wap Euro 2 50 2T -00, F12 R Phantom 50 2T 07-07



◀ **cod. IM07066**
Albero motore Derbi per Piaggio D50B0, D50B1

RIFERIMENTO ORIGINALE

APRILIA	83052R
APRILIA	847026
APRILIA	874224
DERBI	00H02590141

DERBI	83052R
DERBI	847026
DERBI	874224

RICAMBIO

AA00766	GABBIA
---------	--------



◀ **cod. IM07073**
Albero motore Piaggio 50/100 cc 4T

APPLICABILITÀ

APRILIA	SCARABEO 4T 50 4T 02-06, SCARABEO 4T 4V 50 4T-4V 10-12, SCARABEO 4T 4V 50 4T-4V 14-14, SCARABEO 4T 4V NET 50 4T-4V 09-10, SCARABEO 4T RESTYLING EU3 50 4T 06-09, SCARABEO QUATTRO 50 4T-4V 09-09, SPORT CITY ONE 4T 50 4T 08-10, SR MOTARD 4T 4V 50 4T-4V 13-14
DERBI	ATLANTIS 4T 50 4T 04-06, ATLANTIS 4T EU2 50 4T 07-07, BOULEVARD 4T EU2 25KM/H 50 4T 09-09

PIAGGIO	FLY 4T 50 4T 05-07, FLY 4T & 25-30 KM/H 50 4T 08-11, FLY 4T 2V 50 4T 13-15, FLY 4T 2V 25-30KM/H 50 4T 12-17, FLY 4T 4V 50 4T-4V 12-13, FLY 4T MOTORE CHN 50 4T 06-07, LIBERTY 4T 50 4T 00-02, LIBERTY 4T 50 4T 05-08, LIBERTY 4T 3V 25 KM/H 50 4T-3V 16-16, LIBERTY 4T 3V IE 50 4T-3V 15-17, LIBERTY 4T 3V IE E4 50 4T-3V 17-18, LIBERTY 4T DELIVERY - SINGLE 50 4T 10-14, LIBERTY 4T DELIVERY TNT 50 4T 09-09, LIBERTY 4T PTT (DEU) 50 4T 07-12, LIBERTY 4T PTT - DOUBLE - NEXIVE 50 4T 09-17, LIBERTY 4T RST 50 4T 04-04, LIBERTY 4T SPORT 50 4T 06-08, LIBERTY IGET 4T 3V 25KM/H 50 4T-3V 16-16, LIBERTY IGET 4T 3V IE 50 4T-3V 15-17, LIBERTY MOC 4T & ELLE 50 4T 09-16, VESPA ET4 50 4T 00-05, VESPA LX 4T 50 4T 05-09, VESPA LX 4T 4V 50 4T-4V 09-13, VESPA LX 4T 4V TOURING 50 4T-4V 10-13, VESPA PRIMAVERA 4T 2V 25KM/H 50 4T-2V 14-17, VESPA PRIMAVERA 4T 4V 50 4T-4V 13-17, VESPA S 4T 4V & COLLEGE 50 4T-4V 08-12, VESPA SPRINT 4T 2V 25KM/H 50 4T-2V 14-17, VESPA SPRINT 4T 4V 50 4T-4V 14-17, ZIP 4T 50 4T 00-13, ZIP 4T 25KM/H 50 4T 06-16
----------------	--

RIFERIMENTO ORIGINALE

PIAGGIO	969428
---------	--------



◀ **cod. IM07074**
Albero motore KYMCO AGILITY 50 cc 4T

APPLICABILITÀ

KYMCO	AGILITY 4T CARRY 50 4T 11-11, AGILITY 4T R10 50 4T 06-08, AGILITY 4T R12 50 4T 07-08, AGILITY PLUS 4T 50 4T 14-14, AGILITY R12 50 4T 05-05, AGILITY R12 ECS 50 4T 16-16, AGILITY R16 50 4T 08-09, AGILITY R16 50 4T 12-12, AGILITY RS 50 4T 09-09, FILLY 50 4T 98-00, FILLY LX 50 4T 01-02, LIKE 50 4T 09-09, PEOPLE S 4T 50 4T 06-08, SENTO 50 4T 08-08, SUPER 8 4T 50 4T 07-07, SUPER 8 4T 50 4T 09-09, SUPER 8 4T 50 4T 13-13
--------------	--

RIFERIMENTO ORIGINALE

KYMCO	00101068
-------	----------

KYMCO	13000-LDCS-9000
-------	-----------------



◀ **cod. IM07045**
Albero motore per motori Minarelli YP 125

RIFERIMENTO ORIGINALE

Yamaha	5XLE14001100
Mbk	5XLE14001100

Malaguti	77118600
Benelli	R12040201A0

APPLICABILITÀ

BENELLI VELVET 125 4T 99-01

ITALJET JUPITER 125 4T 01-02, MILLENIUM 125 4T 00-02

MALAGUTI MADISON 125 4T 99-01, MADISON R RESTYLING 125 4T 02-02, MADISON R RESTYLING EU2 125 4T 03-04, PHANTOM MAX 125 4T 03-03

MBK DOODO 125 4T 00-00, SKYLINER 125 4T 98-02, SKYLINER E 125 4T 03-03, THUNDER 125 4T 01-02

YAMAHA MAJESTY 125 4T 98-00, MAJESTY (5NR1) 125 4T 01-01, MAJESTY (5NR8) 125 4T 02-02, MAJESTY E 125 4T 03-09, MAXSTER 125 4T 01-02, TEO'S 125 4T 00-00



◀ **cod. IM07050**
Albero motore per scooter Suzuki Burgman 250 cc 4T

RIFERIMENTO ORIGINALE

Suzuki	12200-14F00-000
--------	-----------------

APPLICABILITÀ

Suzuki AN Burgman 250 K3/K6 250 4T 03-06



◀ **cod. IM07052**
Albero motore per scooter Suzuki Burgman 150 cc 4T

RIFERIMENTO ORIGINALE

Suzuki	12200-49F50-000
--------	-----------------

APPLICABILITÀ

SUZUKI UH BURGMAN K2/K6 150 4T 02-06



◀ **cod. IM07054**
Albero motore per motori Minarelli YP 250

RIFERIMENTO ORIGINALE

Aprilia	AP8122470
---------	-----------

APPLICABILITÀ

APRILIA LEONARDO 250 4T 99-04, LEONARDO ST 250 4T 01-01

BENELLI VELVET 250 4T 99-03

ITALJET JUPITER 250 4T 00-02

MALAGUTI MADISON S 250 4T 99-01, PASSWORD 250 4T 05-06, PASSWORD EU3 250 4T 07-08

MBK SKYLINER 250 4T 00-03, SKYLINER ABS 250 4T 03-03

YAMAHA MAJESTY 250 4T 96-03, MAJESTY ABS 250 4T 03-03, MAJESTY DX 250 4T 98-99, X-CITY 250 4T 07-15, X-MAX 250 4T 05-16, X-MAX ABS 250 4T 14-15

RICAMBI

IM07037	BIELLA
---------	--------



◀ **cod. IM07055**
Albero motore Honda SH 125 cc 4T (fino al 2012)

RIFERIMENTO ORIGINALE

Honda	13000KF910
-------	------------

APPLICABILITÀ

HONDA @ [NES] 125 4T 00-06, DYLAN [SES] 125 4T 02-04, PANTHEON IE [FES] 125 4T-2V 03-05, PS I [PES] 125 4T 06-10, SH 125 4T-2V 01-04, SH IE SCOOPY 125 4T-2V 05-12, SILVER WING [FES] 125 4T-2V 07-12



◀ **cod. IM07056**
Albero motore Honda SH 150 cc 4T (fino al 2012)

RIFERIMENTO ORIGINALE

Honda	13000KG910
-------	------------

APPLICABILITÀ

HONDA @ [NES] 150 4T 00-06, DYLAN [SES] 150 4T 02-04, PANTHEON IE [FES] 150 4T-2V 03-05, PS I [PES] 150 4T 06-10, SH 150 4T-2V 01-04, SH IE SCOOPY 150 4T 05-12, SILVER WING [FES] 150 4T-2V 07-12



◀ **cod. IM07057**
Albero motore Kymco 250 cc

RIFERIMENTO ORIGINALE

Kymco	00123900
-------	----------

APPLICABILITÀ

KYMCO B&W 250 4T 00-00, B&W EU2 250 4T 03-03, GRAND DINK 250 4T 01-02, GRAND DINK EU2 250 4T 03-04, PEOPLE LC 250 4T 03-04, PEOPLE S 250 4T 06-06, PEOPLE S I 250 4T 07-07, X CITING 250 4T 05-05, X CITING I 250 4T 06-07, YUP 250 4T 03-03



◀ **cod. IM07067**
Albero motore Piaggio Vespa 125 ET3

APPLICABILITÀ

PIAGGIO VESPA ET3 125 2T 76-83, VESPA PRIMAVERA 125 2T 67-83

RIFERIMENTO ORIGINALE

PIAGGIO	1232966
---------	---------

RICAMBIO

AA00857	GABBIA
---------	--------



◀ cod. **IM07068**
Albero motore Piaggio Vespa 125 PX

APPLICABILITÀ

PIAGGIO VESPA PX 125 2T 98-01, VESPA PX 125 2T 11-16, VESPA PX 30 ANNI 125 2T 07-08, VESPA PX E ARCOBALENO 125 2T 81-97, VESPA PX EU2 125 2T 01-07, VESPA PX 150 2T 98-01, VESPA PX 150 2T 11-16, VESPA PX E ARCOBALENO 150 2T 81-97

RIFERIMENTO ORIGINALE

PIAGGIO	1331545
---------	---------

RICAMBIO

AA00857	GABBIA
---------	--------



◀ cod. **IM07069**
Albero Motore Sym Symphony 125 cc

APPLICABILITÀ

SYM FIDDLE II 125 4T 10-10, JET 4 125 4T 09-10, SYMPHONY 125 4T 09-09, SYMPHONY S 125 4T 09-10, SYMPHONY SR 125 4T 10-10

RIFERIMENTO ORIGINALE

Sym	13000ARA000
-----	-------------



◀ cod. **IM070701**
Albero Motore Piaggio Liberty 125cc (sel.1)

APPLICABILITÀ

APRILIA ATLANTIC EU3 125 4T 06-08, ATLANTIC EU3 125 4T 10-12, MOJITO 125 4T 03-08, SCARABEO EU3 125 4T 06-07, SPORT CITY CUBE 125 4T 08-10, SPORT CITY EU3 125 4T 06-08, SPORT CITY ONE 4T EU3 125 4T 08-11

DERBI BOULEVARD 4T EU3 125 4T 08-12, BOULEVARD EU2 125 4T 04-07, GP1 EU 2 125 4T 06-06, GP1 LOW SEAT EU3 125 4T 07-08, RAMBLA 125 4T 08-09, RAMBLA EU3 2VER 125 4T 08-08, SONAR 4T 125 4T 09-11, VARIANT SPORT 4T EU3 125 4T 12-12, BOULEVARD 4T E3 150 4T 10-10, BOULEVARD EU3 150 4T 04-07, SONAR 4T 150 4T 09-09

GILERA NEXUS EU3 125 4T 07-08, RUNNER VX 125 4T 02-06, RUNNER VX 4T EU3 125 4T 06-07, RUNNER VX RACE 125 4T 06-06, RUNNER VX SC 125 4T 06-07

PIAGGIO BEVERLY 125 4T 01-03, BEVERLY EU3 125 4T 07-08, BEVERLY RST 125 4T 05-07, BEVERLY TOURER EU3 125 4T 07-10, CARNABY 125 4T 07-10, FLY 125 4T 05-07, FLY EU3 125 4T 07-11, HEXAGON GTX 125 4T 00-00, LIBERTY 125 4T 01-02, LIBERTY 4T 125 4T 06-07, LIBERTY 4T EU3 125 4T 06-08, LIBERTY 4T EU3 DELIVERY - TNT 125 4T 08-15, LIBERTY 4T SPORT EU3 125 4T 06-08, LIBERTY RST PTT 125 4T 05-11, LIBERTY SPORT 125 4T 06-06, MP3 125 4T 06-08, SKYPPER 4T 125 4T 00-02, TYPHOON 4T 2V E3 125 4T 10-11, VESPA ET4 125 4T 99-02, VESPA GRANTURISMO 125 4T 03-07, VESPA GRANTURISMO

EU3 125 4T 06-07, VESPA GTS EU3 125 4T 07-12, VESPA GTV 125 4T 06-08, VESPA GTV 4T NAVY EU3 125 4T 08-08, VESPA LX 125 4T 05-06, VESPA LX 4T EU3 TOURING 125 4T 10-11, VESPA LX 4T FL 125 4T 09-09, VESPA LX EU3 125 4T 06-08, VESPA LX EU3 IE 125 4T 09-11, VESPA LXV 4T EU3 125 4T 06-09, VESPA LXV IE 4T 125 4T 10-13, VESPA LXV NAVY EU3 125 4T 07-08, VESPA S 4T EU3 125 4T 07-08, VESPA S 4T IE & COLLEGE 125 4T 09-11, X-EVO 125 4T 07-16, X7 EU3 125 4T 08-08, X8 125 4T 04-06, X8 PREMIUM EU2 125 4T 06-06, X8 PREMIUM EU3 125 4T 06-07, X8 STREET EU2 125 4T 06-07, X9 125 4T 01-02, X9 EVOLUTION 125 4T 03-03, X9 EVOLUTION 125 4T 05-06, X9 EVOLUTION EU3 125 4T 07-07, ZIP 125 4T 00-02, FLY 150 4T 05-07, FLY EU3 150 4T 08-11, LIBERTY 150 4T 01-02, LIBERTY 4T EU3 150 4T 08-08, LIBERTY 4T SPORT EU3 150 4T 08-08, LIBERTY MOC 4T 150 4T 09-13, VESPA LX 150 4T 05-06, VESPA LX 4T FL 150 4T 09-09, VESPA LX EU3 150 4T 06-08, VESPA LX EU3 IE 150 4T 09-11, VESPA LX TOURING 150 4T 10-12, VESPA S 4T 150 4T 08-09, VESPA S 4T IE & COLLEGE 150 4T 09-12, X8 STREET EU2 150 4T 06-08

RIFERIMENTO ORIGINALE

PIAGGIO	8412985001
---------	------------



◀ cod. **IM070702**
Albero Motore Piaggio Liberty 125 cc (sel.2)

APPLICABILITÀ

APRILIA ATLANTIC EU3 125 4T 06-08, ATLANTIC EU3 125 4T 10-12, MOJITO 125 4T 03-08, SCARABEO EU3 125 4T 06-07, SPORT CITY CUBE 125 4T 08-10, SPORT CITY EU3 125 4T 06-08, SPORT CITY ONE 4T EU3 125 4T 08-11

DERBI BOULEVARD 4T EU3 125 4T 08-12, BOULEVARD EU2 125 4T 04-07, GP1 EU 2 125 4T 06-06, GP1 LOW SEAT EU3 125 4T 07-08, RAMBLA 125 4T 08-09, RAMBLA EU3 2VER 125 4T 08-08, SONAR 4T 125 4T 09-11, BOULEVARD 4T E3 150 4T 10-10, BOULEVARD EU3 150 4T 04-07, SONAR 4T 150 4T 09-09

GILERA NEXUS EU3 125 4T 07-08, RUNNER VX 125 4T 02-06, RUNNER VX 4T EU3 125 4T 06-07, RUNNER VX RACE 125 4T 06-06, RUNNER VX SC 125 4T 06-07

PIAGGIO BEVERLY 125 4T 01-03, BEVERLY EU3 125 4T 07-08, BEVERLY RST 125 4T 05-07, BEVERLY TOURER EU3 125 4T 07-10, CARNABY 125 4T 07-10, FLY 125 4T 05-07, FLY EU3 125 4T 07-11, HEXAGON GTX 125 4T 00-00, LIBERTY 125 4T 01-02, LIBERTY 4T 125 4T 06-07, LIBERTY 4T EU3 125 4T 06-08, LIBERTY 4T EU3 DELIVERY - TNT 125 4T 08-15, LIBERTY 4T SPORT EU3 125 4T 06-08, LIBERTY RST PTT 125 4T 05-11, LIBERTY SPORT 125 4T 06-06, MP3 125 4T 06-08, SKYPPEP 4T 125 4T 00-02, TYPHOON 4T 2V E3 125 4T 10-11, VESPA ET4 125 4T 99-02, VESPA GRANTURISMO

125 4T 03-07, VESPA GRANTURISMO EU3 125 4T 06-07, VESPA GTS EU3 125 4T 07-12, VESPA GTV 125 4T 06-08, VESPA GTV 4T NAVY EU3 125 4T 08-08, VESPA LX 125 4T 05-06, VESPA LX 4T EU3 TOURING 125 4T 10-11, VESPA LX 4T FL 125 4T 09-09, VESPA LX EU3 125 4T 06-08, VESPA LX EU3 IE 125 4T 09-11, VESPA LXV 4T EU3 125 4T 06-09, VESPA LXV IE 4T 125 4T 10-13, VESPA LXV NAVY EU3 125 4T 07-08, VESPA S 4T EU3 125 4T 07-08, VESPA S 4T IE & COLLEGE 125 4T 09-11, X-EVO 125 4T 07-16, X7 EU3 125 4T 08-08, X8 125 4T 04-06, X8 PREMIUM EU3 125 4T 06-06, X8 PREMIUM EU3 125 4T 06-07, X8 STREET EU2 125 4T 06-07, X9 125 4T 01-02, X9 EVOLUTION 125 4T 03-03, X9 EVOLUTION 125 4T 05-06, X9 EVOLUTION EU3 125 4T 07-07, ZIP 125 4T 00-02, FLY 150 4T 05-07, FLY EU3 150 4T 08-11, LIBERTY 150 4T 01-02, LIBERTY 4T EU3 150 4T 08-08, LIBERTY 4T SPORT EU3 150 4T 08-08, LIBERTY MOC 4T 150 4T 09-13, VESPA LX 150 4T 05-06, VESPA LX 4T FL 150 4T 09-09, VESPA LX EU3 150 4T 06-08, VESPA LX EU3 IE 150 4T 09-11, VESPA LX TOURING 150 4T 10-12, VESPA S 4T 150 4T 08-09, VESPA S 4T IE & COLLEGE 150 4T 09-12, X8 STREET EU2 150 4T 06-08

RIFERIMENTO ORIGINALE

PIAGGIO	8412985002
---------	------------



◀ cod. **IM07071**
Albero Motore Kymco Agility 125 cc

APPLICABILITÀ

KYMCO AGILITY 125 4T 06-06, AGILITY CARRY 125 4T 11-11, AGILITY EU3 125 4T 06-08, AGILITY PLUS 125 4T 14-14, AGILITY PLUS E4 125 4T 16-16, AGILITY R16 125 4T 08-09, AGILITY RS 125 4T 09-09, LIKE 125 4T 09-09, LIKE LX 125 4T 12-12, MOVIE 125 4T 99-00, MOVIE EU3 125 4T 06-07, MOVIE XL 125 4T 01-01, MOVIE XL EU2 125 4T 03-04, PEOPLE 125 4T 99-00, PEOPLE EU2 125 4T 03-03, PEOPLE EU3 125 4T 07-08, PEOPLE EU3 125 4T 11-11, PEOPLE ONE E4 125 4T 16-16, PEOPLE ONE I 125 4T 13-13, PEOPLE ONE I DD 125 4T 15-15, PEOPLE S 125 4T 05-05, PEOPLE S DD EU3 125 4T 07-08, SUPER 8 125 4T 08-09, VIVIO 125 4T 00-00, AGILITY R16 150 4T 08-09, MOVIE XL 150 4T 01-01, MOVIE XL EU2 150 4T 03-04, PEOPLE 150 4T 99-00, PEOPLE EU2 150 4T 03-03, VIVIO 150 4T 00-00

RIFERIMENTO ORIGINALE

Kymco	123127
-------	--------



◀ cod. **IM07072**
Albero Motore Yamaha X-Max 125 cc

APPLICABILITÀ

MBK CITYLINER EU3 125 4T-4V 08-10, SKYCRUISER 125 4T-4V 07-07

YAMAHA

X-CITY EU3 125 4T-4V 08-11, X-MAX R 125 4T-4V 06-16, X-MAX R ABS 125 4T-4V 11-11, X-MAX RA ABS 125 4T-4V 13-16

RIFERIMENTO ORIGINALE

Yamaha	39DE14003000
--------	--------------

NOVITÀ



◀ cod. **IM07075**

Albero motore Honda SH 125cc ABS dal 2013 Corsa 57,9mm - Spinotto Ø13 mm

APPLICABILITÀ

HONDA SH I ABS 125cc 13-19

RIFERIMENTO ORIGINALE

Honda	13000-K01-900
Honda	13000-K77-V00

NOVITÀ



◀ cod. **IM07076**

Albero motore Honda SH 150cc ABS dal 2013 Corsa 57,9mm - Spinotto Ø14 mm

APPLICABILITÀ

HONDA SH I ABS 150cc 13-19

RIFERIMENTO ORIGINALE

Honda	13000-K02-900
Honda	13000-K78-V00



◀ cod. **IM07077**

Albero motore PIAGGIO VESPA ET3 125 cc 2T Anticipato

APPLICABILITÀ

PIAGGIO VESPA ET3 125 2T 76-83, VESPA PRIMAVERA 125 2T 67-83

RICAMBIO

AA00857	GABBIA
----------------	--------



◀ **cod. 12481N**
Mitsubishi IR/IF
35 Amp/12 Volt, Splined Shaft

MAKE / MODEL	YEAR
Kawasaki ZG1200 Voyager XII	1986-2003
Kawasaki ZR1100	1992-1995



◀ **cod. 12494N**
Bosch IR
50 Amp/12 Volt, w/o Pulley

MAKE / MODEL	YEAR
BMW K1100LT	1992-1999
BMW K1100LT High Line	1997
BMW K1100LT Special Edition	1997
BMW K1100RS	1992-1996
BMW K1100RS SE	1996
BMW K75	1988-1995
BMW K75C	1985-1990
BMW K75RT	1990-1995
BMW K75RT ABS	1991-1995
BMW K75S	1986-1995
BMW K75S ABS	1991-1995
BMW R1100GS	1994-2006
BMW R1100GS ABS	1995-1999
BMW R1100GS SE	1999
BMW R1100R	1994-2000
BMW R1100R SE	1999
BMW R1100RL	2001
BMW R1100RS	1992-2001
BMW R1100RS ABS	1994-2001
BMW R1100RSL	1994-1996
BMW R1100RT	1994-2001
BMW R1100RT SE	2000
BMW R1100RTL	1996-1997
BMW R1100S	1998-2005
BMW R1150GS	1999-2004
BMW R1150GS Adventure	2001-2005
BMW R1150R	2001-2006
BMW R1150R Roadster	2002-2006
BMW R1150RS	2000-2004
BMW R1150RT	2000-2005
BMW R1200C	1998-2004
BMW R1200C Avantgarde	2000-2003
BMW R1200C Classic	1996-2004
BMW R1200C Euro	1998-2002
BMW R1200C Independent	2000-2004
BMW R1200C Montana	2000-2003
BMW R1200C Phoenix	2000-2002
BMW R1200C Stiletto	2001
BMW R850C Classic	1998-2000
BMW R850R	1995-2001
BMW R850R ABS	1996
BMW R850R Special Edition	1997
BMW R850RT	2002-2006



◀ cod. **AM00001**
Albero primario nudo per AM6 1° serie



◀ cod. **AM00002**
Albero secondario nudo per AM6 1° serie



◀ cod. **AM00003**
Albero selettore per AM6



◀ cod. **AM00004**
Raccordo entrata pompa acqua per AM6



◀ cod. **AM00005**
Tappo alimentazione olio per AM6



◀ cod. **AM00006**
Ingranaggio 2a velocità su primario Z=16 per AM6 1° serie



◀ cod. **AM00007**
Ingranaggio 3a-4a velocità su primario Z=19-22 adat. AM6 1° serie



- ◀ cod. **AM00008**
Ingranaggio 5a velocità su primario Z=24 per AM6 1° serie



- ◀ cod. **AM00009**
Ingranaggio 6a velocità su primario Z=25 per AM6 1° serie



- ◀ cod. **AM00010**
Ingranaggio 1a velocità su secondario Z=36 per AM6 1° serie



- ◀ cod. **AM00011**
Ingranaggio 2a velocità su secondario Z=33 per AM6 1° serie



- ◀ cod. **AM00012**
Ingranaggio 3a velocità su secondario Z=29 per AM6 1° serie



- ◀ cod. **AM00013**
Ingranaggio 4a velocità su secondario Z=27 per AM6 1° serie



- ◀ cod. **AM00014**
Ingranaggio 5a velocità su secondario Z=25 per AM6 1° serie



◀ cod. **AM00015**
Ingranaggio 6a velocità su secondario Z=24 per AM6 1° serie



◀ cod. **AM00016**
Ingranaggio doppio intermedio Z=13-24 per AM6 1° serie

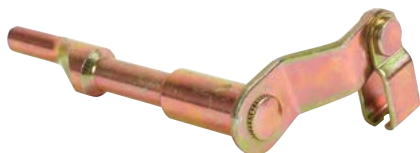

◀ cod. **AM00017**
Leva frizione completa per AM



◀ cod. **AM00018**
Chiavetta per pignone motore AM



◀ cod. **AM00019**
Chiavetta per volano motore AM



◀ cod. **AM00020**
Astuccio a rulli DB 14-12



◀ cod. **AM00021**
OR 11,8x2,4



◀ cod. **AM00022**
Guarnizioni coperchio frizione per AM

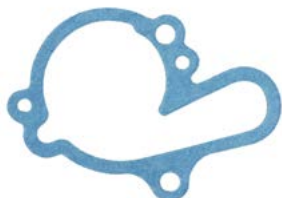

◀ cod. **AM00023**
Guarnizioni corpo pompa acqua per AM



◀ cod. **AM00024**
Paraolio 10x18x8



◀ cod. **AM00025**
Girante con perno per pompa acqua AM



◀ cod. **AM00026**
Interruttore spia folle per AM



◀ cod. **AM00027**
Rullo per ingranaggio condotto pompa per AM



◀ cod. **AM00028**
Rullo riferimento corpo pompa per AM



◀ cod. **AM00030**
Albero messa in moto completo AM6

APPLICABILITÀ

APRILIA CLASSIC 50 2T 92-99, EUROPA 50 2T 90-92, MX 50 2T 04-04, MX MOTARD 50 2T 95-03, PEGASO 50 2T 92-94, RS 50 2T 91-05, RX 50 2T 89-04, RX 3-5 MARCE 50 2T 91-94, RX ENDURO 50 2T 95-03, RX RACING 50 2T 03-06, TUONO 50 2T 03-04

BETA RR 2T 50 EU4 50 2T 18-20, RR 50 RACING EU4 50 2T 18-20, RR ALU 50 2T 08-12, RR ENDURO 50 2T 06-17, RR MOTARD 50 2T 06-17

CH HUSQVARNA SM 50 2T 00-10, WR 50 2T 00-10, WSM 50 2T 00-10

CMC ENDURO 50 2T 11-11, MOTARD 50 2T 11-11

FANTIC CABALLERO MOTARD 50 2T 06-10, CABALLERO REGOLARITÀ 50 2T 06-10, ENDURO COMPETITION EU4 50 2T 18-20, ENDURO PERFORMANCE EU4 50 2T 18-20, MOTARD COMPETITION EU4 50 2T 18-20, MOTARD PERFORMANCE EU4 50 2T 18-20

HM BAJA, DERAPAGE BASIC 50 2T 10-11, CMC 50 2T 10-11, CRE BAJA RR, DERAPAGE RR 50 2T 07-11, CRE BAJA, DERAPAGE 50 2T 07-11, CRE SIX COMPETITION 50 2T 10-11, CRE SIX, BAJA, DERAPAGE 50 2T 95-06, CRE SIX, DERAPAGE COMPETITION 50 2T 07-09, DERAPAGE COMPETITION 50 2T 10-11

MALAGUTI CNK DRAGON 50 2T 05-07, FIFTY EVOLUTION 50 2T 90-93, XSM 50 2T 03-03, XTM 50 2T 03-03

MBK X LIMIT 50 2T 03-04, X POWER 50 2T 03-04

MINARELLI MOTORE AM 3-4-5 50 2T 91-95, MOTORE AM 6 1° SERIE 50 2T 96-11, MOTORE AM 6 2° SERIE 50 2T 12-18

MOTORHISPANIA FURIA 50 2T 97-00, FURIA MAX 50 2T 10-12, RX 50 2T 09-12, RX R 50 2T 09-12

PEUGEOT SUPERMOTARD 50 2T 90-02, XP6 TRAIL S/AVV. ELETTRICO 50 2T 90-02, XR6 RACING CAT. C/AVV.ELETT. 50 2T 90-02

RIEJU MRT 50 2T 09-12, MRT 50 EU4 50 2T 18-20, MRT PRO 50 2T 09-12, MRT PRO EU4 50 2T 18-20, MRT PRO REPLICA EU4 50 2T 18-20, MRT PRO REPLICA SM EU4 50 2T 18-20, MRT PRO SM 50 2T 09-12, MRT PRO SM EU4 50 2T 18-20, MRT SM 50 2T 09-12, MRT SM EU4 50 2T 18-20, MRT TROPHY EU4 50 2T 18-20, MRX 50 2T 01-04, MRX PRO 50 2T 01-04, RR 50 2T 05-06, RS1 50 2T 98-01, RS2 MATRIX 50 2T 05-06, RS2 MATRIX PRO 50 2T 05-06, RS2 NAKED 50 2T 04-05, RS3 EU4 50 2T 18-20, RS3 NKD EU4 50 2T 18-20, SMX E.S./K.S. 50 2T 01-01, SMX PRO E.S./K.S. 50 2T 03-03, SPIKE 50 2T 98-01

SHERCO FACTORY SE-R EU4 50 2T 18-20, FACTORY SE-RS EU4 50 2T 18-20, FACTORY SILVER SM-R EU4 50 2T 18-20, FACTORY SILVER SM-RS EU4 50 2T 18-20, FACTORY SM-R EU4 50 2T 18-20, FACTORY SM-RS EU4 50 2T 18-20, HRD ENDURO 50 2T 09-13, HRD MOTARD 50 2T 09-13

VENT BAJA 50 2T 18-20, BAJA RR 50 2T 18-20, DERAPAGE 50 2T 18-20, DERAPAGE RR 50 2T 18-20

YAMAHA DT R 50 2T 03-11, DT RSM 50 2T 03-05, DT X 50 2T 06-11, TZR 50 2T 03-08, TZR 50 2T 10-11, TZR RR 50 2T 05-05



◀ cod. **AM00031**
Cambio completo AM6 seconda serie

APPLICABILITÀ

MINARELLI MOTORE AM 6 2° SERIE 50 2T 12-18

VENT BAJA 50 2T 18-20, BAJA RR 50 2T 18-20, DERAPAGE 50 2T 18-20, DERAPAGE RR 50 2T 18-20

RICAMBI

AM00032	Albero primario z=12 AM6 2° serie
AM00033	Ingran. 5° marcia su primario z=24 AM6 2a serie
AM00034	Ingran. 3°- 4° marcia su prim. Z=19-22 AM6 2° serie
AM00035	Ingran. 6° marcia su primario z=25 AM6 2° serie
AM00036	Ingran. 2° marcia su primario z=16 AM6 2° serie
AM00037	Albero secondario AM6 2° serie
AM00038	Ingran. 1° marcia su secondario z=36 AM6 2° serie

AM00039	Ingran. 5° marcia su secondario z=25 AM6 2° serie
AM00040	Ingran. 4° marcia su secondario z=27 AM6 2° serie
AM00041	Ingran. 3° marcia su secondario z=29 AM6 2° serie
AM00042	Ingran. 6° marcia su secondario z=24 AM6 2° serie
AM00043	Ingran. 2° marcia su secondario z=33 AM6 2° serie
AM00044	Kit rasamenti e seeger cambio AM6 2° serie



◀ cod. **AM00032**
Albero primario z=12 AM6 seconda serie

APPLICABILITÀ

MINARELLI MOTORE AM 6 2° SERIE 50 2T 12-18

VENT BAJA 50 2T 18-20, BAJA RR 50 2T 18-20, DERAPAGE 50 2T 18-20, DERAPAGE RR 50 2T 18-20

A RICAMBIO PER

AM00031	Cambio completo AM6 2° serie
---------	------------------------------



◀ **cod. AM00033**
Ingran. 5ª marcia su primario z=24 AM6 seconda serie

APPLICABILITÀ

MINARELLI MOTORE AM 6 2° SERIE 50 2T 12-18

VENT

BAJA 50 2T 18-20, BAJA RR 50 2T 18-20, DERAPAGE 50 2T 18-20, DERAPAGE RR 50 2T 18-20

A RICAMBIO PER

AM00031	Cambio completo AM6 2ª serie
---------	------------------------------



◀ **cod. AM00034**
Ingran. 3ª-4ª marcia su primario z=19-22 AM6 seconda serie

APPLICABILITÀ

MINARELLI MOTORE AM 6 2° SERIE 50 2T 12-18

VENT

BAJA 50 2T 18-20, BAJA RR 50 2T 18-20, DERAPAGE 50 2T 18-20, DERAPAGE RR 50 2T 18-20

A RICAMBIO PER

AM00031	Cambio completo AM6 2ª serie
---------	------------------------------



◀ **cod. AM00035**
Ingran. 6ª marcia su primario z=25 AM6 seconda serie

APPLICABILITÀ

MINARELLI MOTORE AM 6 2° SERIE 50 2T 12-18

VENT

BAJA 50 2T 18-20, BAJA RR 50 2T 18-20, DERAPAGE 50 2T 18-20, DERAPAGE RR 50 2T 18-20

A RICAMBIO PER

AM00031	Cambio completo AM6 2ª serie
---------	------------------------------



◀ **cod. AM00036**
Ingran. 2ª marcia su primario z=16 AM6 seconda serie

APPLICABILITÀ

MINARELLI MOTORE AM 6 2° SERIE 50 2T 12-18

VENT

BAJA 50 2T 18-20, BAJA RR 50 2T 18-20, DERAPAGE 50 2T 18-20, DERAPAGE RR 50 2T 18-20

A RICAMBIO PER

AM00031	Cambio completo AM6 2ª serie
---------	------------------------------



◀ **cod. AM00037**
Albero secondario am6 seconda serie

APPLICABILITÀ

MINARELLI MOTORE AM 6 2° SERIE 50 2T 12-18

VENT

BAJA 50 2T 18-20, BAJA RR 50 2T 18-20, DERAPAGE 50 2T 18-20, DERAPAGE RR 50 2T 18-20

A RICAMBIO PER

AM00031	Cambio completo AM6 2ª serie
---------	------------------------------



◀ **cod. AM00038**
Ingran. 1ª marcia su secondario z=36 AM6 2ª serie

APPLICABILITÀ

MINARELLI MOTORE AM 6 2° SERIE 50 2T 12-18

VENT

BAJA 50 2T 18-20, BAJA RR 50 2T 18-20, DERAPAGE 50 2T 18-20, DERAPAGE RR 50 2T 18-20

A RICAMBIO PER

AM00031	Cambio completo AM6 2ª serie
---------	------------------------------



◀ cod. **AM00039**
Ingran. 5ª marcia su secondario z=25 AM6 2ª serie

APPLICABILITÀ

MINARELLI MOTORE AM 6 2° SERIE 50 2T 12-18

VENT

BAJA 50 2T 18-20, BAJA RR 50 2T 18-20, DERAPAGE 50 2T 18-20, DERAPAGE RR 50 2T 18-20

A RICAMBIO PER

AM00031	Cambio completo AM6 2ª serie
---------	------------------------------



◀ cod. **AM00040**
Ingran. 4ª marcia su secondario z=27 AM6 2ª serie

APPLICABILITÀ

MINARELLI MOTORE AM 6 2° SERIE 50 2T 12-18

VENT

BAJA 50 2T 18-20, BAJA RR 50 2T 18-20, DERAPAGE 50 2T 18-20, DERAPAGE RR 50 2T 18-20

A RICAMBIO PER

AM00031	Cambio completo AM6 2ª serie
---------	------------------------------



◀ cod. **AM00041**
Ingran. 4ª marcia su secondario z=27 AM6 2ª serie

APPLICABILITÀ

MINARELLI MOTORE AM 6 2° SERIE 50 2T 12-18

VENT

BAJA 50 2T 18-20, BAJA RR 50 2T 18-20, DERAPAGE 50 2T 18-20, DERAPAGE RR 50 2T 18-20

A RICAMBIO PER

AM00031	Cambio completo AM6 2ª serie
---------	------------------------------



◀ cod. **AM00042**
Ingran. 6ª marcia su secondario z=24 AM6 seconda serie

APPLICABILITÀ

MINARELLI MOTORE AM 6 2° SERIE 50 2T 12-18

VENT

BAJA 50 2T 18-20, BAJA RR 50 2T 18-20, DERAPAGE 50 2T 18-20, DERAPAGE RR 50 2T 18-20

A RICAMBIO PER

AM00031	Cambio completo AM6 2ª serie
---------	------------------------------



◀ cod. **AM00043**
Ingran. 2ª marcia su secondario z=33 AM6 seconda serie

APPLICABILITÀ

MINARELLI MOTORE AM 6 2° SERIE 50 2T 12-18

VENT

BAJA 50 2T 18-20, BAJA RR 50 2T 18-20, DERAPAGE 50 2T 18-20, DERAPAGE RR 50 2T 18-20

A RICAMBIO PER

AM00031	Cambio completo AM6 2ª serie
---------	------------------------------



◀ cod. **AM00044**
Kit rasamenti e seeger cambio AM6 seconda serie

APPLICABILITÀ

MINARELLI MOTORE AM 6 2° SERIE 50 2T 12-18

VENT

BAJA 50 2T 18-20, BAJA RR 50 2T 18-20, DERAPAGE 50 2T 18-20, DERAPAGE RR 50 2T 18-20

A RICAMBIO PER

AM00031	Cambio completo AM6 2ª serie
---------	------------------------------



NOVITÀ

Codice Reference	Sigla Sygn	Ah	Spunto-CCA (-18°C) A	Tipo - Type	Poli Poles	Lunghezza Length	Larghezza Width	Altezza Height
0012180	YB4L-B	4	50	Standard - Conventional	⊖ ⊕	120	70	92
0012240	YB5L-B	5	55	Standard - Conventional	⊖ ⊕	120	60	130
0012260	YB10L-A2	11	160	Standard - Conventional	⊖ ⊕	134	90	146
0012310	YTX4L-BS	3	40	AGM Senza Manutenzione - AGM Maintenance Free	⊖ ⊕	112	71	86
0012320	YTX12-BS	10	150	AGM Senza Manutenzione - AGM Maintenance Free	⊕ ⊖	150	87	130
0012330	YTX9-BS	8	120	AGM Senza Manutenzione - AGM Maintenance Free	⊕ ⊖	150	87	105
0012340	YB12AL-A	12	165	Standard - Conventional	⊖ ⊕	133	80	160
0012350	YTX7A-BS	6	85	AGM Senza Manutenzione - AGM Maintenance Free	⊕ ⊖	150	87	96
0012380	YTX5L-BS	4	60	AGM Senza Manutenzione - AGM Maintenance Free	⊖ ⊕	112	70	105
0012390	YTX14-BS	12	200	AGM Senza Manutenzione - AGM Maintenance Free	⊕ ⊖	150	87	147
0012420	YB7L-B2	8	90	Standard - Conventional	⊖ ⊕	136	76	132
0012430	YTX7L-BS	6	85	AGM Senza Manutenzione - AGM Maintenance Free	⊖ ⊕	112	70	128
0012470	YT12A-BS	10	140	AGM Senza Manutenzione - AGM Maintenance Free	⊕ ⊖	150	87	106
0012480	YB10L-B	11	160	Standard - Conventional	⊖ ⊕	134	90	145
0012500	YTZ7S-BS	6	100	AGM Senza Manutenzione - AGM Maintenance Free	⊖ ⊕	114	70	105
0012510	YTZ12S-BS	11	210	AGM Senza Manutenzione - AGM Maintenance Free	⊕ ⊖	150	87	110
0012520	YT7B-BS	6	85	AGM Senza Manutenzione - AGM Maintenance Free	⊕ ⊖	150	65	95
0012530	YT9B-BS	8	115	AGM Senza Manutenzione - AGM Maintenance Free	⊕ ⊖	150	70	105
0012540	YTZ10S-BS	8,6	190	AGM Senza Manutenzione - AGM Maintenance Free	⊕ ⊖	150	87	93
0012550	YT12B-BS	10	160	AGM Senza Manutenzione - AGM Maintenance Free	⊕ ⊖	150	69	132
0012560	52015	22	440	AGM Sigillata - AGM READY Factory Activated	⊖ ⊕	181	77	173
0012570	YB10L-BP	12	160	Standard - Conventional	⊖ ⊕	134	90	145
0012580	YTZ14S-BS	11,2	230	AGM Senza Manutenzione - AGM Maintenance Free	⊕ ⊖	150	87	110
0012600	YB9-B-BS	9	120	AGM Senza Manutenzione - AGM Maintenance Free	⊕ ⊖	135	75	135
0012610	YTX14AH-BS	12	210	AGM Senza Manutenzione - AGM Maintenance Free	⊕ ⊖	134	89	166
0012620	YTX14AHL-BS	12	210	AGM Senza Manutenzione - AGM Maintenance Free	⊖ ⊕	134	89	166
0012630	YTX20-BS	18	270	AGM Senza Manutenzione - AGM Maintenance Free	⊕ ⊖	175	87	155
0012640	YTX20L-BS	18	270	AGM Senza Manutenzione - AGM Maintenance Free	⊖ ⊕	175	87	155
0012650	YB12A-A	12	165	Standard - Conventional	⊕ ⊖	134	80	160
0012660	YB4L-B-BS	4	40	AGM Senza Manutenzione - AGM Maintenance Free	⊖ ⊕	120	70	92
0012700	YB5L-B-BS	5	55	AGM Senza Manutenzione - AGM Maintenance Free	⊖ ⊕	120	61	127
0012710	YB30CL-B	30	300	Standard - Conventional	⊖ ⊕	168	132	190
0012720	YTX16-BS	14	230	AGM Senza Manutenzione - AGM Maintenance Free	⊕ ⊖	150	87	161
0012730	H60-N30L-A	30	280	Standard - Conventional	⊖ ⊕	183	128	170
0012740	YB4L-B-GEL	4	40	GEL Senza Manutenzione - GEL Maintenance Free	⊖ ⊕	120	70	92
0012750	YB9-B-GEL	9	120	GEL Senza Manutenzione - GEL Maintenance Free	⊕ ⊖	137	75	138
0012760	YTX9-GEL	8	135	GEL Senza Manutenzione - GEL Maintenance Free	⊕ ⊖	150	87	105
0012770	YTX7A-GEL	6	105	GEL Senza Manutenzione - GEL Maintenance Free	⊕ ⊖	150	87	95
0012780	YTX7L-GEL	6	100	GEL Senza Manutenzione - GEL Maintenance Free	⊖ ⊕	113	70	130
0012790	YTX20HL-GEL	20	310	GEL Senza Manutenzione - GEL Maintenance Free	⊖ ⊕	175	87	155
0012800	YB14L-A2	14	180	Standard - Conventional	⊖ ⊕	134	89	166
0012820	52015-GEL	22	280	GEL Senza Manutenzione - GEL Maintenance Free	⊖ ⊕	181	76	167
0012840	GEL 12-19	19	170	GEL Senza Manutenzione - GEL Maintenance Free	⊖ ⊕	185	80	170



◀ cod. **IM07024**
Biella Vespa 50 S PK XL normale



◀ cod. **IM07031**
Biella scooter Piaggio/Gilera 50 cc



◀ cod. **IM07032**
Biella con gabbia per motore scooter 50 cc Minarelli/Yamaha



◀ cod. **IM07033**
Biella con gabbia per motore Minarelli AM AXE 16 mm



◀ cod. **IM07036**
Biella con gabbia per motore Minarelli AM6 AXE 18 mm



◀ cod. **IM07037**
Biella completa per motore Minarelli YP 250 cc

APPLICABILITÀ

APRILIA LEONARDO 250 4T 99-04, LEONARDO ST 250 4T 01-01, LEONARDO 300 4T 02-04
BENELLI VELVET 250 4T 99-03
ITALJET JUPITER 250 4T 00-02
MALAGUTI MADISON S 250 4T 99-01, PASSWORD 250 4T 05-06, PASSWORD EU3 250 4T 07-08

MBK

SKYLINER 250 4T 00-03, SKYLINER ABS 250 4T 03-03, KILIBRE 300 4T 03-06

YAMAHA

MAJESTY 250 4T 96-03, MAJESTY ABS 250 4T 03-03, MAJESTY DX 250 4T 98-99, X-CITY 250 4T 07-15, X-MAX 250 4T 05-16, X-MAX ABS 250 4T 14-15, VERSITY 300 4T 03-06



◀ cod. **BA00006**
Blocco accensione e serratura MBK Nitro



◀ cod. **BA00007**
Blocco accensione e serratura MBK Booster Stunt



◀ cod. **BA00014**
Blocco accensione e serratura Kymco Agility 50 cc



◀ cod. **BD00001**
Bobina A.T. scooter 50 cc Minarelli/Yamaha con volano giapponese

RIFERIMENTO ORIGINALE

Ducati	432261000
--------	-----------



◀ **cod. B000001**
Bobina A.T. per Kymco Agility

RIFERIMENTO ORIGINALE

Kymco	00168770
Kymco	00168585
Kymco	00169202

Kymco	00169400
Malaguti	02412700
Piaggio	58083R

APPLICABILITÀ

APRILIA SPORT CITY ONE 4T EU3 125 4T 08-11, SPORT CITY STREET 125 4T 12-12

DERBI BOULEVARD 125 4T 03-04, BOULEVARD 4T EU3 125 4T 08-12, BOULEVARD EU2 125 4T 04-07, GP1 EU 2 125 4T 06-06, BOULEVARD 150 4T 03-04, BOULEVARD 4T E3 150 4T 10-10, BOULEVARD EU3 150 4T 04-07, BOULEVARD EU2 200 4T 05-06, GP1 250 4T 06-07, GP1 LOW SEAT EU3 250 4T 07-08

GILERA NEXUS EU3 125 4T 07-08, RUNNER 4T ST EU3 125 4T 08-16, RUNNER VX 125 4T 05-06, RUNNER VX 4T EU3 125 4T 06-07, RUNNER VXR 4T ST EU3 200 4T 08-11, RUNNER VXR EU3 200 4T 07-07, OREGON 250 4T 06-10

KYMCO AGILITY 4T CARRY 50 4T 11-11, AGILITY 4T R10 50 4T 06-08, AGILITY 4T R12 50 4T 07-08, AGILITY R12 50 4T 05-05, AGILITY RS 50 4T 09-09, B&W 50 2T 02-02, B&W EU2 50 2T 03-03, DINK LC 50 2T 98-02, FILLY LX 50 4T 01-02, LIKE 50 4T 09-09, MXER 50 2T 02-03, MXER EU2 50 2T 04-04, PEOPLE S 50 2T 05-08, SNIPER 50 2T 93-93, SNIPER DD 50 2T 94-96, SUPER 9 50 2T 00-00, SUPER 9 EU2 50 2T 03-04, VITALITY 4T 50 4T 04-04, AGILITY 125 4T 06-06, AGILITY EU3 125 4T 06-08,

AGILITY R16 125 4T 08-09, AGILITY RS 125 4T 09-09, HEROISM 125 4T 95-97, LIKE 125 4T 09-09, MOVIE 125 4T 99-00, MOVIE EU3 125 4T 06-07, MOVIE XL 125 4T 01-01, MOVIE XL EU2 125 4T 03-04, SUPER 8 125 4T 08-09, VIVIO 125 4T 00-00, AGILITY R16 150 4T 08-09, HEROISM 150 4T 95-97, MOVIE EU3 150 4T 06-07, MOVIE LX 150 4T 01-01, MOVIE XL EU2 150 4T 03-04, VIVIO 150 4T 00-00, LIKE LX 200 4T 12-12

MALAGUTI CIAK MASTER EU3 125 4T 06-06, CIAK MASTER EURO 2 200 4T 06-06

PIAGGIO FLY 125 4T 05-07, FLY EU3 125 4T 07-11, MP3 125 4T 06-08, SKYPPER 4T 125 4T 00-02, TYPHOON 4T 2V E3 125 4T 10-11, X-EVO 125 4T 07-16, X7 EU3 125 4T 08-08, X8 125 4T 04-06, X8 PREMIUM EU2 125 4T 06-06, X8 PREMIUM EU3 125 4T 06-07, X8 STREET EU2 125 4T 06-07, X9 125 4T 01-02, X9 EVOLUTION 125 4T 03-03, X9 EVOLUTION 125 4T 05-06, X9 EVOLUTION EU3 125 4T 07-07, ZIP 125 4T 00-02, FLY 150 4T 05-07, FLY EU3 150 4T 08-11, X8 STREET EU2 150 4T 06-08, X9 AMALFI 180 4T 00-03, X8 200 4T 05-07, X9 200 4T 02-03, X9 EVOLUTION 200 4T 03-03, X9 EVOLUTION 250 4T 04-04, X9 EVOLUTION 250 4T 06-06



◀ **cod. B000002**
Bobina A.T. per Booster R - Ovetto - Majesty 125/150 dal 2000

RIFERIMENTO ORIGINALE

Yamaha	3KJ823101000
--------	--------------

APPLICABILITÀ

MBK BOOSTER 50 2T 90-04, BOOSTER 50 2T 90-94, BOOSTER NG 50 2T 95-03, BOOSTER ROCKET 50 2T 97-98, BOOSTER SPIRIT 50 2T 96-00, BOOSTER SPIRIT 50 2T 03-03, BOOSTER SPIRIT EURO2 50 2T 03-03, BOOSTER TRACK 50 2T 96-98, EVOLIS 50 2T 92-95, FIZZ 50 2T 94-95, FLIPPER 50 2T 98-04, FLIPPER EURO 2 50 2T 03-03, FORTE 50 2T 94-96, NITRO 50 2T 97-04, NITRO EURO 2 50 2T 03-03, OVETTO 50 2T 97-04, OVETTO EURO 2 50 2T 02-02, STUNT 50 2T 00-02, NITRO 100 2T 00-02, OVETTO 100 2T 99-02, DOODO 125 4T 00-00, SKYLINER 125 4T 98-00, SKYLINER 150 4T 00-00

YAMAHA AEROX 50 2T 97-02, AEROX 50 2T 04-16, AEROX EURO 2 50 2T 03-03, AEROX NAKED 50 2T 13-16, AEROX R 50 2T 99-00, AXIS 50 2T 95-96, BREEZE 50 2T 94-95, BW'S 50 2T 97-16, BW'S BUMP 50 2T 97-98, BW'S EASY 50 2T 13-13, BW'S NAKED 50 2T 03-04, BW'S NAKED 50 2T 09-16, BW'S NEXT GENERATION 50 2T 97-06, BW'S ORIGINAL 50 2T 99-01, BW'S ORIGINAL EURO 2 50 2T 03-03, DT R 50 2T 07-11, DT X 50 2T 07-11, NEO'S 50 2T 97-02, NEO'S 50 2T 04-16, NEO'S EASY 50 2T 13-13, NEO'S EURO 2 50 2T 02-02, SLIDER 50 2T 00-02, WHY 50 2T 98-05, WHY EURO 2 50 2T 03-05, AEROX 100 2T 00-02, NEO'S 100 2T 99-02, MAJESTY 125 4T 98-00, TEO'S 125 4T 00-00, MAJESTY 150 4T 00-00



◀ **cod. B000003**
Bobina A.T. Piaggio Liberty 125/150cc

RIFERIMENTO ORIGINALE

Piaggio	82597R
---------	--------

APPLICABILITÀ

APRILIA ATLANTIC 125 4T 03-05, ATLANTIC EU3 125 4T 06-08, ATLANTIC EU3 125 4T 10-12, MOJITO 125 4T 03-08, SCARABEO 125 4T 03-06, SPORT CITY 125 4T 04-06, SPORT CITY CUBE 125 4T 08-10, SPORT CITY EU3 125 4T 06-08, SR MAX 125 4T 11-14, SPORT CITY CUBE 250 4T 08-12, ATLANTIC 300 4T 10-11, SPORT CITY STREET 300 4T 12-12, SR MAX 300 4T 11-14, ATLANTIC SPRINT 400 4T 05-08, SCARABEO LIGHT 400 4T 06-08, ATLANTIC SPRINT 500 4T 05-08, SCARABEO LIGHT 500 4T 06-08

DERBI GP1 LOW SEAT EU3 125 4T 07-08, RAMBLA 125 4T 08-09, RAMBLA EU3 2VER 125 4T 08-08, SONAR 4T 125 4T 09-11, SONAR 4T 150 4T 09-09, RAMBLA 300 4T 10-11

GILERA DNA 125 4T 01-01, NEXUS IE EU3 125 4T 08-10, RUNNER VX 125 4T 00-04, RUNNER VX RACE 125 4T 06-06, RUNNER VX SC 125 4T 06-07, RUNNER VXR RACE 200 125 4T 06-06, DNA 180 4T 01-01, RUNNER VXR 200 4T 02-06, NEXUS EU3 250 4T 06-07, NEXUS SP EU3 250 4T 06-07, NEXUS EU3 300 4T 08-11, FUOCO 4T 4V IE E3 LT 500 4T 13-14, FUOCO IE EU3 500 4T 07-13, NEXUS 500 4T 03-05, NEXUS EU3 500 4T 06-11, NEXUS SP EU3 500 4T 06-07

PIAGGIO BEVERLY 125 4T 01-03, BEVERLY EU3 125 4T 07-08, BEVERLY EURO 3 MIC 125 4T 07-07, BEVERLY EURO 3 SPORT 125 4T 07-08, BEVERLY RST 125 4T 04-07, BEVERLY TOURER EU3 125 4T 07-10, CARNABY 125 4T 07-10, HEXAGON GTX 125 4T 00-00, LIBERTY 125 4T 98-02, LIBERTY 4T 125 4T 06-07, LIBERTY 4T 2V EURO3 125 4T 09-12, LIBERTY 4T EU3 125 4T 06-08, LIBERTY 4T EU3 DELIVERY - SINGLE 125 4T 07-15, LIBERTY 4T EU3 DELIVERY - TNT 125 4T 08-15, LIBERTY 4T SPORT EU3 125 4T 06-08, LIBERTY RST 125 4T 04-05, LIBERTY RST PTT 125 4T 05-11, LIBERTY SPORT 125 4T 06-06, SFERA 125 4T 95-97, SUPER HEXAGON GTX 125 4T 01-02, VESPA ET4 125 4T 96-02, VESPA GRANTURISMO 125 4T 03-07,

VESPA GRANTURISMO EU3 125 4T 06-07, VESPA GTS EU3 125 4T 07-12, VESPA GTV 125 4T 06-08, VESPA GTV 4T NAVY EU3 125 4T 08-08, VESPA LX 125 4T 05-06, VESPA LX 4T FL 125 4T 09-09, VESPA LX EU3 125 4T 06-08, VESPA LXV 4T EU3 125 4T 06-09, VESPA LXV NAVY EU3 125 4T 07-08, VESPA S 4T EU3 125 4T 07-08, LIBERTY 150 4T 01-02, LIBERTY 4T EU3 150 4T 08-08, LIBERTY 4T SPORT EU3 150 4T 08-08, LIBERTY MOC 4T 150 4T 09-13, VESPA LX 150 4T 05-06, VESPA LX 4T FL 150 4T 09-09, VESPA LX EU3 150 4T 06-08, SUPER HEXAGON GTX 12 180 4T 01-02, CARNABY 200 4T 07-08, LIBERTY 200 4T 06-06, LIBERTY 4T EU3 200 4T 06-08, LIBERTY 4T SPORT EU3 200 4T 06-07, LIBERTY RST 200 4T 04-04, LIBERTY SPORT 200 4T 06-06, VESPA GRANTURISMO 200 4T 06-07, BEVERLY 250 4T 05-07, BEVERLY CRUISER 250 4T 07-09, BEVERLY EURO 3 MIC 250 4T 07-07, BEVERLY IE EU3 250 4T 06-08, BEVERLY RST 250 4T 04-05, BEVERLY SPORT 250 4T 06-08, BEVERLY TOURER EU3 250 4T 07-09, CARNABY 250 4T 08-09, MP3 250 4T 06-08, MP3 LT 250 4T 08-09, MP3 MIC 250 4T 08-09, VESPA GT 60 EU3 250 4T 06-07, VESPA GTS 250 4T 05-16, VESPA GTS ABS 250 4T 05-12, VESPA GTV 250 4T 06-09, VESPA GTV 4T NAVY EU3 250 4T 07-07, X-EVO 250 4T 07-16, X7 EU3 250 4T 08-08, X8 EU3 250 4T 05-08, BEVERLY TOURER EU3 300 4T 09-10, BEVERLY EU3 400 4T 06-07, BEVERLY TOURER EU3 400 4T 08-10, MP3 400 4T 07-08, MP3 IE LT TOURING 400 4T 11-11, MP3 IE LT/SPORT 400 4T 08-10, MP3 MIC 400 4T 08-10, MP3 RL TOURING 400 4T 11-11, X-EVO 400 4T 07-11, X8 EU3 400 4T 06-08, BEVERLY 500 4T 02-06, BEVERLY IE EU3 500 4T 06-08, MP3 LT BUSINESS ABS 500 4T 14-16, MP3 LT SPORT/BUSINESS 500 4T 11-13, MP3 RL SPORT-BUSINESS 500 4T 11-12, MP3 SPORT ABS 500 4T 14-16, X9 500 4T 01-02, X9 EVOLUTION 500 4T 03-07, X9 EVOLUTION ABS 500 4T 06-07

◀ cod. **CPS25**

Honda, Kawasaki, Suzuki, Yamaha
12 Volt



MAKE / MODEL	YEAR
Honda ANF 125 Innova	2003-2010
Honda CG125 Titan	1984-2008
Honda CR80R	1982
Honda CX500	1978-1979
Honda CX500C Custom	1979-1982
Honda CX500D Deluxe	1979-1981
Honda CX500EC Sports	1982
Honda CX500TC Turbo	1982
Honda CX650C Custom	1983
Honda FES125 Pantheon	1988-2002
Honda GL500 Silver Wing	1981-1982
Honda GL500I Silver Wing Interstate	1981-1982
Honda H100-A	1980-1982
Honda MB5	1980-1981
Honda NH125 Lead	1986-1987
Honda NH80 Vision	1986-1994
Honda NX500	1988-1999
Honda NX650	1988-1999
Honda QR50	1984-2000
Honda RVT1000R RC51	2000-2006
Honda SCV100 Lead	2003-2008
Honda VTR1000SP	2000-2006
Honda XR125L	2003-2006
Kawasaki AR125	1983-1991
Kawasaki EL250 Eliminator	1987-1996
Kawasaki EL252 Eliminator 252	1996-2003
Kawasaki ER250 Scorpion	1983-1988
Kawasaki EX250 Ninja 250R	1988-2007
Kawasaki EX305 GPZ	1983-1994
Kawasaki KE175	1980-1983
Kawasaki KLE500	1991-2000
Kawasaki KLR250	1985-2005
Kawasaki KLR600 KL600	1984-1994
Kawasaki ZZR250 EX250	1990-2002
Suzuki AN250 Burgman	1988-2002
Suzuki AN400 Burgman	1999-2006
Suzuki AN400S Burgman Type S	2003-2006
Suzuki DR750S	1988-1989
Suzuki DR800S	1990-1997
Suzuki PE175	1978-1981
Suzuki PE250	1977-1982
Suzuki PE400	1980-1981
Suzuki RG125BU Gamma I	1988
Suzuki RG125UC Gamma I	1985-1988
Suzuki RM100	1976-1981
Suzuki RM125	1975-1981
Suzuki RM400	1978-1980
Suzuki RM465	1981-1982
Suzuki RM500	1983-1985
Suzuki RM80	1977-1981
Suzuki RS175	1980-1982
Suzuki RS250	1980-1981
Suzuki TS100	1982-1986

◀ cod. **CPS25** - continued

MAKE / MODEL	YEAR
Suzuki TS125	1982
Suzuki TS185	1973-1981
Suzuki TS250	1971-1978
Suzuki TS250X	1984-1989
Yamaha SR500	1978-1995
Yamaha SZR660	1995-1997
Yamaha TDM850	1996-2001
Yamaha TT500	1977-1981
Yamaha WR250F	2001-2002
Yamaha WR250Z	1994-1998
Yamaha WR400F	1998-2000
Yamaha WR426F	2001-2002
Yamaha XT500	1976-1985
Yamaha XT550	1982-1983
Yamaha XT600E	1990-2002
Yamaha XT600Z Tenere	1983-1985
Yamaha XTZ660 Tenere	1991-1998
Yamaha XV535 Virago	1987-2002
Yamaha XV535SP Virago Special	1994-1997
Yamaha YFM700R Raptor	2006-2015
Yamaha YP250 Majesty	1996-2003
Yamaha YP400 Majesty	2004-2014
Yamaha YZ250	1997-2002
Yamaha YZ250F	2001-2002
Yamaha YZ400F	1998-1999
Yamaha YZ426F	2000-2002



◀ cod. **CPS27**

Honda, Kawasaki, Suzuki, Yamaha
12 Volt

MAKE / MODEL	YEAR
Honda ATC110	1981-1984
Honda ATC125M	1984
Honda ATC185S	1979-1983
Honda ATC200	1981-1983
Honda ATC200E	1982-1983
Honda ATC200ES	1984
Honda ATC200M	1984
Honda ATC200S	1984
Honda ATC200X	1983-1985
Honda ATC250R	1981-1984
Honda CB125TD	1982-1987
Honda CB250RS	1980-1983
Honda CL250SC	1981-1984
Honda CR125R	1999
Honda CR250R	1981-1999
Honda CR450R	1981
Honda CR480R	1982-1983
Honda CR80R	1980-1986
Honda CRM50R	1992-1996
Honda CRM75R	1989-1994
Honda FL250 Odyssey	1981-1984
Honda FT500 Ascot	1982-1983
Honda MB5	1982

◀ cod. **CPS27** - continued

MAKE / MODEL	YEAR
Honda MBX50	1983-1986
Honda MBX80	1983-1986
Honda MT5 / MT50	1980-1993
Honda MTX125	1983-1995
Honda MTX200	1983-1985
Honda MTX50	1982-1995
Honda NB50 Aero	1984
Honda NC50	1982-1983
Honda NH125 Aero	1983-1984
Honda NH80 Mascot	1983-1984
Honda NH80 Vision	1983-1984
Honda NU50	1982-1983
Honda NV50	1984
Honda NX50	1980-1982
Honda PX50	1981-1986
Honda PXR50	1984-1987
Honda XL125S	1979-1983
Honda XL185S	1979-1983
Honda XL200R	1983
Honda XL250R	1982-1983
Honda XL250R	1982
Honda XR185	1979
Honda XR200	1980-1983
Honda XR200R	1981-1983
Honda XR250R	1981-1983
Honda XR350R	1983-1984
Honda XR500R	1981-1982
Kawasaki AE50	1981-1982
Kawasaki AE80	1981-1984
Kawasaki AR50	1981-1994
Kawasaki AR80	1981-1990
Kawasaki KDX200	1995-2006
Kawasaki KDX200R	1997-2001
Kawasaki KDX220R	2002-2005
Kawasaki KDX250	1991-1995
Kawasaki KL250 Super Sherpa	2000-2010
Kawasaki KLX250	2006-2007
Suzuki DS80	1978-2000
Suzuki GS450E	1983-1988
Suzuki GS450G	1982-1983
Suzuki GS450GA	1983-1985
Suzuki GS450L	1983-1988
Suzuki GS450TX	1983
Suzuki GSX250E	1982-1983
Suzuki GSX400E	1982
Suzuki JR80	2001-2004
Suzuki RG125FU Gamma II	1992-1994
Suzuki RG125U Wolf	1992
Suzuki RGV250	1988-1996
Suzuki RMX250	1989-1999
Suzuki TS125	1989-1994
Suzuki TS50	1984-1994
Yamaha BL125 Beluga	1985-1987
Yamaha DT125 LC	1982-1988
Yamaha RD125	1982-1989

◀ **cod. CPS27** - continued

MAKE / MODEL	YEAR
Yamaha RD80	1982-1984
Yamaha RX100	1985-1996
Yamaha SA50 Passola	1980-1984
Yamaha T50 Townmate	1986
Yamaha T80 Townmate	1983-1996
Yamaha XT125R	2005-2007
Yamaha XT125X Supermotard	2005-2007
Yamaha YZ125	1983-1989
Yamaha YZ250	1983-1989
Yamaha YZ80	1983



◀ **cod. CPS28**
Kawasaki, Yamaha
12 Volt

MAKE / MODEL	YEAR
Kawasaki VN900B Vulcan 900 Classic	2006-2015
Kawasaki VN900C Vulcan 900 Custom	2007-2015
Kawasaki VN900D Vulcan 900 Classic LT	2006-2015
Yamaha RD250	1978-1979
Yamaha TDM850	1991-1995
Yamaha XV1000 Virago	1984-1989
Yamaha XV1100 Virago	1986-1999
Yamaha XV1100SP Virago Special	1996-1998
Yamaha XV700 Virago	1984-1987
Yamaha XV750 Virago	1988-1997
Yamaha XVS11 V-Star 1100 Custom	2004-2009
Yamaha XVS11 V-Star 1100 Midnight Custom	2005-2009
Yamaha XVS1100 Custom Dragstar	1999-2002
Yamaha XVS1100 V Star 1100 Custom	1999-2003
Yamaha XVS1100A V Star 1100 Classic	1999-2006
Yamaha XVS1100AT V Star 1100 Silverado	2003
Yamaha XVS11A V-Star 1100 Classic	2004-2009
Yamaha XVS11A V-Star 1100 Silverado	2004-2009



◀ **cod. CPS29**
Honda, Kawasaki, Suzuki, Yamaha
12 Volt

MAKE / MODEL	YEAR
Honda CR125R	2001
Honda CR250R	2001-2007
Honda TRX450ER Electric Start	2006-2014
Honda TRX450R	2004-2009
Honda XR650R	2000-2007
Kawasaki KDX200	1983-1994
Kawasaki KDX250	1981-1984
Kawasaki KFX400	2003-2006
Kawasaki KLX400R	2003-2004
Kawasaki KLX400SR	2003-2004
Kawasaki KX100	2001-2005
Kawasaki KX125	1982-1994
Kawasaki KX250	1982-1994
Kawasaki KX500	1985-1987
Kawasaki KX60	1985-1990



 **cod. CPS29 - continued**

MAKE / MODEL	YEAR
Kawasaki KX85	2001-2005
Kawasaki KXF250 Tecate 4	1987-1988
Suzuki DR100	1985-1990
Suzuki DR650RE Dakar	1994-1995
Suzuki DR650RSE Dakar	1991-1996
Suzuki GSXR50	1986-1987
Suzuki LT125	1983-1987
Suzuki LT160	2003-2004
Suzuki LT160E	1989-1992
Suzuki LT250EF	1985-1986
Suzuki LT250R QuadRacer	1985-1992
Suzuki LT-4WD QuadRunner 250	1990-1998
Suzuki LT-500X KingQuad	2009-2014
Suzuki LT-A450AZ KingQuad	2007-2010
Suzuki LT-A450X KingQuad AXi 4x4	2007-2010
Suzuki LT-A700X KingQuad 4x4	2005-2007
Suzuki LT-A750X KingQuad	2008-2013
Suzuki LT-F160 QuadRunner	1990-2004
Suzuki LT-F250 QuadRunner	1990-2001
Suzuki LT-F250F QuadRunner 4x4	1999-2002
Suzuki LT-F300 KingQuad 4x4	1999-2002
Suzuki LT-F4WDX King Quad 300	1991-1998
Suzuki PE175	1982-1984
Suzuki RM100	2003
Suzuki RM125	1982-1995
Suzuki RM80	1982-2001
Suzuki UH125 Burgman	2002-2006
Yamaha BW80	1986-1990
Yamaha CG50 Jog	1988-1991
Yamaha CS50R Jog R	2002-2009
Yamaha CS50Z Jog RR	2003-2010
Yamaha CV80 Beluga	1983-1987
Yamaha CW50 BWs Original	2004-2009
Yamaha CW50 Zuma	1989-1990
Yamaha CW50 Zuma II	1997-2001
Yamaha CW50RS BWs	1996-2005
Yamaha CW50RSP BWs Spy	1997-1998
Yamaha CW50T BWs B-Wizz	1990-1994
Yamaha DT125 R	1988-2003
Yamaha DT125 RE	2004-2007
Yamaha DT125 X	2005-2006
Yamaha DT50X Supermotard	2007-2008
Yamaha EW50 Slider	2000-2004
Yamaha IT200	1984-1986
Yamaha IT250	1983
Yamaha IT490	1983-1984
Yamaha LC50M Bop	1980
Yamaha PW80	1983-2009
Yamaha QT50	1979-1987
Yamaha SR185	1997-2000
Yamaha SV80 Snoscoot	1988-1990
Yamaha TDR125	1991-2002
Yamaha TT250	1995-2002
Yamaha TT350	1986-1987
Yamaha TTR110E	2008-2016

◀ cod. **CPS29** - continued

MAKE / MODEL	YEAR
Yamaha TTR125	2000-2013
Yamaha TTR125E	2003-2016
Yamaha TTR125L	2000-2013
Yamaha TTR125LE	2003-2016
Yamaha TTR125LW	2000-2013
Yamaha TTR125LWE	2003-2016
Yamaha TTR125S	2003-2007
Yamaha TTR225	1999-2004
Yamaha TTR230	2005-2016
Yamaha TTR250	1999-2006
Yamaha TTR90	2000-2007
Yamaha TTR90E	2003-2007
Yamaha TTR90R	2000-2007
Yamaha TTR90S	2000-2007
Yamaha TW125	1999-2004
Yamaha TW200	1998-2016
Yamaha TY250R	1984-1994
Yamaha TY350	1985-1986
Yamaha TZR125	1987-1993
Yamaha TZR125R	1992-1993
Yamaha TZR125RR	1994-1995
Yamaha TZR50	2003-2008
Yamaha WR200R	1992-1995
Yamaha WR250Z	1991-1993
Yamaha WR500Z	1992-1993
Yamaha XC125 TR Cygnus	1999-2001
Yamaha XG250 Tricker	2005
Yamaha XN125 Teos	2000-2002
Yamaha XN125 Teos	1982
Yamaha XQ125 Maxster	2001-2003
Yamaha XT225	1995-2007
Yamaha XT250	2008-2012
Yamaha YE50 Zest	1993-1995
Yamaha YFA-1 Breeze125	1989-2004
Yamaha YFB250FW Timberwolf 4x4	1994-2000
Yamaha YFM100 Champ	1989-1991
Yamaha YFM125 Raptor	2011-2013
Yamaha YFM125G Grizzly 125	2004-2013
Yamaha YFM200 Moto-4	1985-1990
Yamaha YFM225 Moto-4	1986-1988
Yamaha YFM250 Moto-4	1989-1991
Yamaha YFM250 Raptor SE	2008-2012
Yamaha YFM250B Big Bear 250	2006-2009
Yamaha YFM250BT Bruin 250 2WD	2005-2006
Yamaha YFM250F Timberwolf 2WD	1992-1999
Yamaha YFM250R Raptor	2008-2013
Yamaha YFM250X Bear Tracker	1999-2004
Yamaha YFM350BA Bruin 350 2WD	2004-2006
Yamaha YFM350ER Moto-4	1987-1995
Yamaha YFM350FA Bruin Auto 4x4	2004-2006
Yamaha YFM350FG Grizzly 350 4WD	2007-2014
Yamaha YFM350FG Grizzly 350 4WD Hunter	2012-2014
Yamaha YFM350FW Big Bear 4x4	1987-1999
Yamaha YFM350FX Wolverine 350	1995-2001
Yamaha YFM350G Grizzly 350 2WD	2007-2014

◀ **cod. CPS29** - continued

MAKE / MODEL	YEAR
Yamaha YFM350R Raptor 350	2004-2013
Yamaha YFM350RSE Raptor 350	2005-2007
Yamaha YFM350U Big Bear 2x4	1996-1999
Yamaha YFM350X Warrior	1987-2001
Yamaha YFM350X Wolverine 350	2006-2009
Yamaha YFM400A Kodiak	2000-2004
Yamaha YFM400FA Kodiak 400 4WD	2000-2006
Yamaha YFM400FW Kodiak 400 4WD	1993-1999
Yamaha YFM450DAE Grizzly 450 4WD Hunting	2014
Yamaha YFM450FA Kodiak 450 4x4	2003-2006
Yamaha YFM450FG Grizzly 450 4WD	2011-2014
Yamaha YFM450FG Grizzly 450 4WD	2007-2010
Yamaha YFM450FGH Grizzly 450 4WD Hunter	2007-2013
Yamaha YFM450FGI Grizzly 450 4WD	2011-2014
Yamaha YFM450FGI Grizzly 450 4WD	2007-2010
Yamaha YFM450FGP Grizzly 450 EPS 4WD	2011-2014
Yamaha YFM450FX Wolverine 4x4	2006-2010
Yamaha YFM450GPH Grizzly 450 EPS 4WD Hunter	2011-2014
Yamaha YFM4FG Grizzly 400	2007-2008
Yamaha YFM50 Raptor	2004-2009
Yamaha YFM600FWA Grizzly 600	1998-2001
Yamaha YFM660F Grizzly 4x4	2002-2008
Yamaha YFM660R Raptor	2001-2005
Yamaha YFM80 Badger	1992-2001
Yamaha YFM80 Grizzly	2005-2008
Yamaha YFM80 Moto-4	1985-1988
Yamaha YFM80 Raptor 80	2002-2008
Yamaha YFS200 Blaster	1997-2007
Yamaha YFU1W Pro Hauler	1989
Yamaha YH50 Why	1999-2006
Yamaha YJ50 Vino	2001-2004
Yamaha YJ50 Vino Classic	2002-2005
Yamaha YN100 Neos	1999-2003
Yamaha YN50 (2T) Neos	1998-2009
Yamaha YP125 Majesty	1998-2006
Yamaha YQ100 Aerox	2000-2002
Yamaha YQ50 Aerox	1999-2009
Yamaha YT60 Zinger	1984-1985
Yamaha YTM200 Tri-Moto	1983-1986
Yamaha YTZ250 Tri-Moto	1985-1986
Yamaha YZ125	1996-2003
Yamaha YZ250	1994-2004
Yamaha YZ490	1983-1990
Yamaha YZ80	1993-2001
Yamaha YZ80 LW	1994-2001



◀ **cod. CPS32**

Suzuki
12 Volt

MAKE / MODEL	YEAR
Suzuki DR125SE	1994-1996
Suzuki DR200SE	1996-2009
Suzuki GN125E	1991-1997



- ◀ cod. **FZ00368**
Campana frizione per motore scooter 50 cc Minarelli/Yamaha Ø 105 mm



- ◀ cod. **FZ00369**
Campana frizione per motore scooter 50 cc Minarelli/Yamaha Ø 107 mm



- ◀ cod. **FZ00375**
Campana frizione Honda @ - SH 125/150

RIFERIMENTO ORIGINALE

Honda	22101KCW850
Kymco	00127702

Malaguti	65044600
Keeway	200093120000

APPLICABILITÀ

HONDA @ [NES] 125 4T 00-06, DYLAN [SES] 125 4T 02-04, PANTHEON IE [FES] 125 4T-2V 03-05, PS I [PES] 125 4T 06-10, SH 125 4T-2V 01-04, SH IE SCOOPI 125 4T-2V 05-12, SILVER WING [FES] 125 4T-2V 07-12, @ [NES] 150 4T 00-06, DYLAN [SES] 150 4T 02-04, PANTHEON IE [FES] 150 4T-2V 03-05, PS I [PES] 150 4T 06-10, SH 150 4T-2V 01-04, SH IE SCOOPI 150 4T 05-12, SILVER WING [FES] 150 4T-2V 07-12

KEEWAY OUTLOOK 125 4T 07-08, OUTLOOK 150 4T 07-08

KYMCO AGILITY 125 4T 06-06, AGILITY EU3 125 4T 06-08, AGILITY PLUS 125 4T 14-14, AGILITY R16 125 4T 08-09, AGILITY R16 125 4T 12-12, AGILITY RS 125 4T 09-09, HEROISM 125 4T 95-97, K-XCT I 125 4T 12-14, LIKE 125 4T 09-09, MOVIE 125 4T 99-00, MOVIE EU3 125 4T 06-07, MOVIE XL 125 4T 01-01, MOVIE XL EU2 125 4T 03-04, PEOPLE 125 4T 99-00, PEOPLE EU3 125 4T 07-08, PEOPLE EU3 125 4T 11-11, PEOPLE ONE I 125 4T 13-13, PEOPLES 125 4T 05-05, PEOPLE S DD EU3 125 4T 07-08,

MALAGUTI SUPER 8 125 4T 08-09, VIVIO 125 4T 00-00, AGILITY R16 150 4T 08-09, HEROISM 150 4T 95-97, MOVIE EU3 150 4T 06-07, MOVIE XL 150 4T 01-01, MOVIE XL EU2 150 4T 03-04, PEOPLE 150 4T 99-00, PEOPLE EU2 150 4T 03-03, VIVIO 150 4T 00-00, AGILITY I PLUS 200 4T 14-14, AGILITY R16 200 4T 12-12, AGILITY R16 200 4T 10-10, LIKE IE 200 4T 09-09, LIKE LX 200 4T 12-12, PEOPLES 200 4T 05-05, PEOPLES I 200 4T 07-07

BLOG IE 125 4T 09-10, CENTRO IE EU3 125 4T 08-09, CENTRO SL IE EU3 125 4T 09-10, CIAK MASTER 125 4T 04-04, CIAK MASTER 150 4T 04-04, BLOG IE 160 4T 09-10, CENTRO IE EU3 160 4T 08-09, CENTRO SL IE EU3 160 4T 09-10, CIAK MASTER EURO 2 200 4T 06-06



- ◀ cod. **FZ00376**
Campana frizione per motore scooter 50 cc Piaggio

RIFERIMENTO ORIGINALE

Piaggio	289933
---------	--------



- ◀ cod. **FZ00377**
Campana frizione per motore scooter 125/150/180 4T Piaggio

RIFERIMENTO ORIGINALE

Piaggio	8440494
Aprilia	8440494
Gilera	8440494

Derbi	8440494
Malaguti	42606500
Peugeot	756258

APPLICABILITÀ

APRILIA ATLANTIC 125 4T 03-05, ATLANTIC ARRECIFE 125 4T 03-05, SCARABEO 125 4T 04-06, SPORT CITY 125 4T 04-06, ATLANTIC 200 4T 03-05, ATLANTIC ARRECIFE 200 4T 03-05, SPORT CITY 200 4T 04-06, SCARABEO 250 4T 04-06

DERBI BOULEVARD 125 4T 02-04, BOULEVARD EU2 125 4T 04-07, GP1 EU 2 125 4T 06-06, BOULEVARD 150 4T 02-04, BOULEVARD EU3 150 4T 04-07

GILERA DNA 125 4T 01-01, RUNNER VX 125 4T 00-06, DNA 180 4T 01-01, RUNNER 180 4T 00-01, RUNNER VXR 180 4T 00-01

MALAGUTI MADISON S RESTYLING 200 4T 02-02

PIAGGIO BEVERLY 125 4T 01-03, SKYPPER 4T 125 4T 00-02, SUPER HEXAGON GTX 12 125 4T 01-02, VESPA ET4 125 4T 99-02, X9 125 4T 01-02, ZIP 125 4T 00-02, SKYPPER 4T 150 4T 00-02, VESPA ET4 150 4T 99-02, HEXAGON GTX 180 4T 00-00, SUPER HEXAGON GTX 12 180 4T 01-02, X9 AMALFI 180 4T 00-03, BEVERLY 200 4T 01-03, VESPA GRANTURISMO 200 4T 03-05, VESPA GTS EU3 200 4T 07-12, VESPA GTV EU3 200 4T 06-08

RENAULT FULLTIME 125 4T 02-03



◀ cod. **FZ00379**
Campana frizione per motore scooter 125 cc Minarelli/Yamaha

RIFERIMENTO ORIGINALE

Yamaha	4CWE66110000
Yamaha	5DSE66110000

Yamaha	5XLE66110000
--------	--------------

APPLICABILITÀ

ITALJET JUPITER 125 4T 01-02, MILLENNIUM 125 4T 00-02
MALAGUTI MADISON 125 4T 99-01, MADISON R RESTYLING 125 4T 02-02, MADISON R RESTYLING EU2 125 4T 03-04, PHANTOM MAX 125 4T 03-03
MBK DOODO 125 4T 00-00, FLAMET 125 4T 95-99, SKYLINER 125 4T 98-02, SKYLINER E 125 4T 03-03, THUNDER 125 4T 01-02

YAMAHA BW'S 4T 125 4T 10-10, CYGNUS R (XC K) 125 4T 97-98, CYGNUS R (XC) 125 4T 99-03, CYGNUS X (NXC) 125 4T 04-06, CYGNUS X IE EU3 (NXC) 125 4T 07-11, CYGNUS125 (XCT) 125 4T 95-98, MAJESTY 125 4T 98-00, MAJESTY (SNR1) 125 4T 01-01, MAJESTY (SNR8) 125 4T 02-02, MAJESTY E 125 4T 03-09, MAXSTER 125 4T 01-02, TEO'S 125 4T 00-00, FLY ONE R (XC) 150 4T 97-98



◀ cod. **FZ00380**
Campana frizione per motore scooter 50 cc Aprilia D. Tech

RIFERIMENTO ORIGINALE

Aprilia	AP2MDA000426
---------	--------------



◀ cod. **FZ00384**
Campana frizione per Piaggio Beverly 500 cc 4T

RIFERIMENTO ORIGINALE

Piaggio	825176
---------	--------

APPLICABILITÀ

APRILIA ATLANTIC 500 4T 01-04, SCARABEO 500 4T 03-06
GILERA FUOCO IE EU3 500 4T 07-13, NEXUS 500 4T 03-05, NEXUS EU3 500 4T 06-11, NEXUS SP EU3 500 4T 06-07
MALAGUTI SPIDER MAX GT 500 4T 04-05, SPIDER MAX GT EU3 500 4T 06-06, SPIDER MAX RS 500 4T 08-08
PEUGEOT GEOPOLIS IE EU3 400 4T-4V 90-02, SATELIS EU3 400 4T 07-12, GEOPOLIS IE EU3 500 4T-4V 90-02, SATELIS EU3 500 4T 90-02

PIAGGIO BEVERLY EU3 400 4T 06-07, BEVERLY TOURER EU3 400 4T 08-10, MP3 400 4T 07-08, MP3 IE LT TOURING 400 4T 11-11, MP3 IE LT/SPORT 400 4T 08-10, MP3 MIC 400 4T 08-10, MP3 RL TOURING 400 4T 11-11, X-EVO 400 4T 07-11, X8 EU3 400 4T 06-08, BEVERLY 500 4T 02-06, BEVERLY IE EU3 500 4T 06-08, MP3 LT SPORT/BUSINESS 500 4T 11-13, MP3 RL SPORT-BUSINESS 500 4T 11-12, X9 500 4T 01-02, X9 EVOLUTION 500 4T 03-07



◀ cod. **FZ00391**
Campana frizione Honda SH 300 cc

RIFERIMENTO ORIGINALE

Honda	22100KFG000
-------	-------------

APPLICABILITÀ

HONDA PANTHEON [FES] 125 2T 98-02, PANTHEON [FES] 150 2T 98-02, FORESIGHT [FES] 250 4T 98-99, FORZA [NSS] 250 4T-2V 02-07, JAZZ ES REFLEX [NSS] 250 4T-2V 01-04, JAZZ REFLEX [NSS] 250 4T-2V 01-01, SH IE SCOOPY 300 4T-4V 07-19



◀ cod. **FZ00395**
Campana frizione Piaggio 125cc

RIFERIMENTO ORIGINALE

Piaggio	8440494
---------	---------

Piaggio	875973
---------	--------

APPLICABILITÀ

APRILIA ATLANTIC EU3 125 4T 06-08, ATLANTIC EU3 125 4T 10-12, MOJITO 125 4T 03-08, SCARABEO 125 4T 03-03, SCARABEO EU3 125 4T 06-07, SPORT CITY CUBE 125 4T 08-10, SPORT CITY EU3 125 4T 06-08, SPORT CITY ONE 4T EU3 125 4T 08-11, SPORT CITY STREET 125 4T 12-12, SR MOTARD 125 4T-2V 12-14, MOJITO 150 4T 03-07, SPORT CITY CUBE 200 4T 08-10, SPORT CITY EU3 200 4T 06-08, ATLANTIC EU3 250 4T 06-08, SCARABEO LIGHT 250 4T 06-08, SPORT CITY CUBE 250 4T 08-12, SPORT CITY EU3 250 4T 06-08, ATLANTIC 300 4T 10-11, SCARABEO LIGHT 300 4T 09-10, SPORT CITY CUBE 300 4T 08-10, SPORT CITY STREET 300 4T-4V 12-12

DERBI BOULEVARD 4T EU3 125 4T 08-12, GP1 LOW SEAT EU3 125 4T 07-08, RAMBLA 125 4T 08-09, BOULEVARD EU2 200 4T 05-06, GP1 250 4T 06-07, GP1 LOW SEAT EU3 250 4T 07-08, RAMBLA 250 4T 08-09, RAMBLA EU3 2VER 250 4T 08-08, RAMBLA 300 4T 10-11

GILERA NEXUS EU3 125 4T 07-08, NEXUS IE EU3 125 4T 08-10, RUNNER VXR 200 4T 02-06, NEXUS EU3 250 4T 06-07, NEXUS EU3 300 4T 08-11

MALAGUTI MADISON 3 125 4T 06-09, MADISON R 180 4T 01-02, PHANTOM MAX 200 4T 03-03, MADISON 3 250 4T 06-09, MADISON RS 250 4T 04-04, PHANTOM MAX 250 4T 04-04

PIAGGIO BEVERLY EU3 125 4T 07-08, BEVERLY RST 125 4T 04-07, BEVERLY TOURER EU3 125 4T 07-10, CARNABY 125 4T 07-10, FLY 125 4T 05-07, HEXAGON GTX 125 4T 00-00, LIBERTY 125 4T 98-02, MP3 125 4T 06-08, MP3 IBRIDO 125 4T 09-10, MP3 IE 125 4T 08-09, MP3 IE TOURING 125 4T 11-12, MP3 YOURBAN ERL 125 4T 11-13, VESPA GRANTURISMO 125 4T 03-07, VESPA GRANTURISMO EU3 125 4T 06-07, VESPA GTS 4T IE SUPER 125 4T 09-16, VESPA LX 125 4T 05-06, VESPA LX 4T EU3 TOURING 125 4T 10-11, VESPA LX 4T FL 125 4T 09-09, VESPA LX EU3 125 4T 06-08, VESPA LX EU3 IE 125 4T 09-11, VESPA LXV 4T EU3 125 4T 06-09, VESPA LXV IE 4T 125 4T 10-13, VESPA LXV NAVY EU3 125 4T 07-08, VESPA S 4T EU3 125 4T 07-08, VESPA S 4T IE & COLLEGE 125 4T 09-11, X-EVO 125 4T 07-16, X7 EU3 125 4T 08-08, X7 EVO IE EU3 125 4T 09-10, X8 125 4T 04-06, FLY 150 4T 05-07, LIBERTY 150 4T 01-02, VESPA LX 150 4T 05-06, VESPA LX EU3 150 4T 06-08, VESPA LX EU3 IE 150 4T 09-11, X8 STREET EU2 150 4T 06-08,

CARNABY 200 4T 07-08, LIBERTY 200 4T 06-06, LIBERTY 4T SPORT EU3 200 4T 06-07, VESPA GRANTURISMO 200 4T 06-07, X8 200 4T 04-07, BEVERLY 250 4T 05-07, BEVERLY IE EU3 250 4T 06-08, BEVERLY TOURER EU3 250 4T 07-09, MP3 250 4T 06-08, MP3 LT 250 4T 08-09, MP3 MIC 250 4T 08-09, VESPA GT 60 EU3 250 4T 06-07, VESPA GTS 250 4T 05-16, VESPA GTS ABS 250 4T 05-12, VESPA GTV 250 4T 06-09, X-EVO 250 4T 07-16, X7 EU3 250 4T 08-08, BEVERLY TOURER EU3 300 4T 09-10, CARNABY CRUISER 300 4T 09-12, MP3 4T 4V IE LT IBRIDO 300 4T 10-11, MP3 IE LT 300 4T 10-11, MP3 IE LT TOURING 300 4T 11-13, MP3 IE LT/SPORT 300 4T 11-14, MP3 IE MIC 300 4T 10-11, MP3 IE TOURING 300 4T 11-12, MP3 YOURBAN ERL 300 4T 11-15, MP3 YOURBAN LT ERL 300 4T 11-12, VESPA GTS SUPER 300 4T 08-16, VESPA GTV VIA MONTENAPOLIONE 300 4T 10-10, X7 EVO IE EU3 300 4T 09-10



◀ cod. **FZ00397**
Campana frizione Yamaha X-Max 250 Ø 145

RIFERIMENTO ORIGINALE

Yamaha	5GM166110000
--------	--------------

APPLICABILITÀ

APRILIA LEONARDO 250 4T 02-04, LEONARDO 300 4T 02-04

ITALJET JUPITER 250 4T 00-00

MALAGUTI MADISON S 250 4T 99-01, PASSWORD 250 4T 05-06, PASSWORD EU3 250 4T 07-08

MBK SKYLINER 250 4T 00-03, SKYLINER ABS 250 4T 03-03, KILIBRE 300 4T 03-06

YAMAHA MAJESTY 250 4T 00-03, MAJESTY ABS 250 4T 03-03, X-CITY 250 4T 07-15, X-MAX 250 4T 05-16, X-MAX ABS 250 4T 14-15, VERSITY 300 4T 03-06



◀ cod. **FZ00399**
Campana frizione Kymco Xciting 300 cc

RIFERIMENTO ORIGINALE

Kymco	00127980
-------	----------

APPLICABILITÀ

KYMCO B&W 250 4T 00-00, B&W EU2 250 4T 03-03, GRAND DINK 250 4T 01-02, GRAND DINK EU2 250 4T 03-04, PEOPLE LC 250 4T 03-04, PEOPLE S 250 4T 06-06, X CITING I 250 4T 06-07, YUP 250 4T 03-03, X CITING I 300 4T 08-08, X CITING I R 300 4T 08-09



◀ cod. **FZ00402**
Campana Frizione Suzuki Burgman 400cc K7-L3

RIFERIMENTO ORIGINALE

Suzuki	21220-05H20-000
--------	-----------------

APPLICABILITÀ

SUZUKI AN BURGMAN K7/L0 400 4T 07-10, AN BURGMAN L1 400 4T 11-11, AN BURGMAN L2 400 4T 12-12, AN BURGMAN L3 400 4T 13-13, AN BURGMAN L4 400 4T 14-14, AN BURGMAN L5 400 4T 15-15, AN BURGMAN L6 400 4T 16-16



◀ cod. **FZ00404**
Campana Frizione Honda Vision 110cc

RIFERIMENTO ORIGINALE

Honda	22100-GFM-900
-------	---------------

APPLICABILITÀ

Honda Vision 110 [NSC] 110 4T-2V 12-12



◀ cod. **FZ00406**
Campana Frizione Honda PCX125cc

RIFERIMENTO ORIGINALE

Honda	22100-KWN-900
-------	---------------

APPLICABILITÀ

Honda PCX 125 125 4T-2V 10-13



◀ cod. **FZ00408**
Campana Frizione Kymco Downtown 200/300cc

RIFERIMENTO ORIGINALE

Kymco	122150
-------	--------

APPLICABILITÀ

KYMCO DOWNTOWN I 200 4T 10-10, PEOPLE GTI 200 4T 10-10, DOWNTOWN ABS 300 4T 10-10, DOWNTOWN I 300 4T 09-09, DOWNTOWN I 300 4T 11-11, DOWNTOWN I ABS 300 4T 11-16, PEOPLE GTI 300 4T 10-11



◀ cod. **FZ00412**
Campana Frizione Suzuki Burgman 125cc K7-L3

RIFERIMENTO ORIGINALE

Suzuki	21220-20E50-000
--------	-----------------

APPLICABILITÀ

SUZUKI UH BURGMAN K7/LO 125 4T 07-10, UH BURGMAN L1 125 4T 11-11, UH BURGMAN L3 125 4T 13-13, UX SIXTEEN K8/LO 125 4T 08-10, UX SIXTEEN L1 125 4T 11-11, UX SIXTEEN K8/LO 150 4T 08-10, UX SIXTEEN L1 150 4T 11-11



◀ cod. **FZ00415**
Campana frizione Yamaha X-MAX 125cc

RIFERIMENTO ORIGINALE

Yamaha	1B9E66110000
--------	--------------

APPLICABILITÀ

YAMAHA X-CITY EU3 125 4T-4V 08-11, X-MAX R 125 4T-4V 06-16, X-MAX R ABS 125 4T-4V 11-11, X-MAX RA ABS 125 4T-4V 13-16



◀ cod. **FZ00416**
Campana frizione Sym Symphony 125/150cc

RIFERIMENTO ORIGINALE

Sym	22101M9Q000
-----	-------------

APPLICABILITÀ

SYM ATTILA 125 4T 99-00, EURO MX 125 4T 02-02, EURO MX EU2 125 4T 03-04, FIDDLE II 125 4T 08-10, GTS JOYMAX 125 4T 06-07, HD EU2 125 4T-4V 03-04, HD EU3 125 4T-4V 07-08, HD EVO 125 4T-4V 05-06, HD EVO EU3 125 4T-4V 07-08, HD EVO EU3 125 4T-4V 10-11, HD EVO TAMBURO EU3 125 4T-4V 08-09, HD2 125 4T-4V 11-11, JET 4 125 4T 09-10, JET V 125 4T 11-11, JOYRIDE EU2 125 4T-4V 05-06, JOYRIDE EU3 125 4T-4V 07-07, JOYRIDE EVO 125 4T-4V 09-10, MEGALO 125 4T 06-07, NEW DUKE 125 4T 00-01, SHARK 125 4T 99-02, SUPER DUKE 125 4T 99-02, SYMPHONY 125 4T 09-09, SYMPHONY S 125 4T 09-10, SYMPHONY SR 125 4T 10-10, SYMPLY 125 4T 07-08, SYMPLY II 125 4T 09-10, VS 125 4T-4V 06-06, VS EU3 125 4T-4V 07-08, ATTILA 150 4T 99-00, EURO MX 150 4T 02-02, EURO MX EU2 150 4T 03-04, FIDDLE II 150 4T 10-10, SHARK 150 4T 00-01, SYMPHONY 150 4T 09-09, SYMPHONY S 150 4T 10-10, SYMPHONY SR 150 4T 10-10, VS 150 4T-4V 06-06, VS EU3 150 4T-4V 07-08, TRACK RUNNER 180 4T 06-07



◀ cod. **FZ00420**
Campana frizione piaggio vespa primavera 125cc 3V Iget

APPLICABILITÀ

PIAGGIO LIBERTY IGET 4T 3V IE 125 4T-3V 15-17, VESPA PRIMAVERA 4T 3V E4 IGET ABS 125 4T-3V 16-17, VESPA SPRINT IGET 4T 3V ABS (EMEA) 125 4T-3V 16-17



◀ cod. **FZ00421**
Campana frizione piaggio liberty 125cc 3V Iget

APPLICABILITÀ

PIAGGIO LIBERTY 4T 3V IE E3 125 4T-3V 13-14, VESPA LX PRIMAVERA 4T 3V IE 125 4T-3V 13-17, VESPA SPRINT 4T 3V IE 125 4T-3V 14-15



- ◀ cod. **CB03002**
Carburatore SHA 13-13 (Si) 1851
- ◀ cod. **CB03003**
Carburatore SHA 13-13 (Ciao,PX) 2044
- ◀ cod. **CB03008**
Carburatore SHBC 19-19 (Vespa) 773
- ◀ cod. **CB03013**
Carburatore PHVA 17.5 ED (Sfera-Zip)1012
- ◀ cod. **CB03014**
Carburatore PHBN 17.5 LS (Booster-Amico) 3067
- ◀ cod. **CB03016**
Carburatore PHVA 17,5 LS Phantom 1097



- ◀ cod. **CB03020**
Carburatore PHBG 19 DS (R.2631) con resca depressore e arrivo olio



- ◀ cod. **CB03021**
Carburatore PHBG 19 DD scooter Piaggio (R.2685) con resca depressore e arrivo olio



- ◀ cod. **CB03022**
Carburatore PHBG 21 DS scooter (R.2632) con resca depressore e arrivo olio



- ◀ cod. **CB03023**
Carburatore PHBG 21 BS (R.2660) con resca depressore e arrivo olio



- ◀ cod. **CB03024**
Carburatore PHBG 21 BD scooter Piaggio (R.2665) con resca depressore e arrivo olio



- ◀ cod. **CB03025**
Carburatore PHBG 21 BS plurimarce (R.2671) con resca depressore e arrivo olio

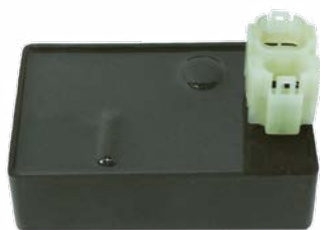

◀ **cod. HNC1001**

Honda CDI Module
12 Volt

MAKE / MODEL	YEAR
Honda XL600V Transalp	1989-1990



◀ **cod. HNC1018**

Honda CDI Module
12 Volt

MAKE / MODEL	YEAR
Honda XR250R	1996-2004



◀ **cod. HNC1047**

Honda CDI Module
12 Volt

MAKE / MODEL	YEAR
Honda NX650	1988-1989
Honda XR650L	1993-2016



SCOOTER 50 cc

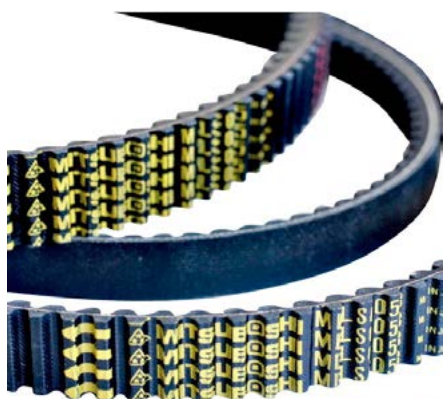

◀ cod. **9934180** **BANDO**
Cinghia Peugeot Kisbee 50 cc 4T

RIFERIMENTO ORIGINALE

Peugeot	724257
---------	--------

APPLICABILITÀ

Peugeot KISBEE 4T 50 4T 10-17

◀ cod. **9935240** **MITSUBOSHI**
Cinghia di trasmissione per motori scooter 50 cc Honda

RIFERIMENTO ORIGINALE

Honda	23100GW2013
-------	-------------

APPLICABILITÀ

HONDA BALI 50 2T 93-99, SFX / SXR 50 2T 95-01, SHADOW 50 2T 98-01

PEUGEOT BUXY 50 2T 90-02, BUXY RS 50 2T 90-02, ELYSEO 50 2T 90-02, JET FORCE 50 2T 90-02, LUDIX 50 2T 90-02, SPEEDAKE 50 2T 90-02, SPEEDFIGHT 50 2T 97-04, SPEEDFIGHT LC 50 2T 97-04, SQUAB 50 2T 90-02, TREKKER 50 2T 90-02, VIVACITY 50 2T 90-02, X-FIGHT 50 2T 00-02

◀ cod. **9935270** **MITSUBOSHI**
Cinghia di trasmissione per motori scooter 50 cc Minarelli/Yamaha

RIFERIMENTO ORIGINALE

Aprilia	AP8206109
Benelli	R16140011A0

Yamaha	SRNE76411000
--------	--------------

APPLICABILITÀ: SCOOTER 50 cc

APRILIA AMICO 50 2T 94-94, AMICO 50 2T 96-98, AMICO GL/GLE 50 2T 93-95, AMICO LX/SPORT/CAT 50 2T 92-93, AREA 51 50 2T 98-00, GULLIVER 50 2T 95-98, GULLIVER LC 50 2T 96-98, RALLY 50 2T 95-03, RALLY LIQUID COOLED 50 2T 96-99, SCARABEO 50 2T 93-05, SR (ORIZZONTALE) 50 2T 94-96, SR (VERTICALE) 50 2T 93-93, SR LIQUID COOLED 50 2T 94-96, SR RACING 50 2T 97-99, SR STEALTH 50 2T 97-00, SR WWW 50 2T 97-01

ATALA CAROSELLO 50 2T 99-01

BENELLI 491 GT 50 2T 98-99, 491 NAKED 50 2T 02-02, 491 RACING 50 2T 98-99, 491 RR 50 2T 99-01, 491 SP 50 2T 99-99, 491 SPORT 50 2T 98-99, 491 ST 50 2T 99-01, K2 50 2T 98-01, K2 LIQUID COOLED 50 2T 98-01, PEPE 50 2T 99-01, PEPE LX 50 2T 03-04

BETA ARK 50 2T 96-08, ARK LC 50 2T 96-08, CHRONO 50 2T 95-96, EIKON 50 2T 99-03, QUADRA 50 2T 95-95, QUADRA 50 2T 99-01, TEMPO 50 2T 93-02, TEMPO 50 2T 95-95

ITALJET DRAGSTER 50 2T 98-02, PISTA 2 50 2T 97-98, SCOOP 2 50 2T 96-98, YANKEE 50 2T 93-97

KTM K50 50 2T 96-01

MACAL THUNDER 50 2T 95-96

MALAGUTI CENTRO SL 50 2T 94-98, CIAK 50 2T 99-01, CIAK EURO 2 2,3 50 2T 03-03, CIAK EURO2 50 2T 01-03, CIAK MASTER EURO 2 50 2T 06-06, F12 PHANTOM 50 2T 94-98, F12 PHANTOM EURO 2 50 2T 02-02, F12 PHANTOM EURO 2 2,3 50 2T 03-04, F12 PHANTOM LC 50 2T 94-98, F12 PHANTOM LC EURO 2 2,3 50 2T 03-04, F12 R PHANTOM LC 50 2T 07-10, F12 RESTYLING EURO 1 50 2T 99-02, F12 RESTYLING EURO 2 50 2T 06-06, F12 RESTYLING LC EURO 2 50 2T 06-06, F15 FIRE FOX 50 2T 96-98, F15 FIRE FOX AIR COOLED 50 2T 05-06, F15 FIRE FOX EURO 2 50 2T 02-06, F15 FIRE FOX EURO 2 2,3 50 2T 03-04

MBK BOOSTER 50 2T 90-04, BOOSTER 50 2T 90-94, BOOSTER EURO 2 50 2T 04-04, BOOSTER NG 50 2T 95-03, BOOSTER ROCKET 50 2T 97-98, BOOSTER SPIRIT 50 2T 96-00, BOOSTER SPIRIT 50 2T 03-03, BOOSTER SPIRIT EURO2 50 2T 03-03, BOOSTER TRACK 50 2T 96-98, FLIPPER 50 2T 98-04, FLIPPER EURO 2 50 2T 03-03, MACH G 50 2T 02-04, MACH G LC 50 2T 02-04, NITRO 50 2T 97-04, NITRO EURO 2 50 2T 03-03, OVETTO 50 2T 97-04, OVETTO EURO 2 50 2T 02-02, STUNT 50 2T 00-02

MOTRON SYNCRO 50 2T 98-00, THUNDER 50 2T 95-98

RIEJU FIRST 50 2T 95-98, WINDY 50 2T 95-98

YAMAHA AEROX 50 2T 97-02, AEROX 50 2T 04-16, AEROX EURO 2 50 2T 03-03, AEROX NAKED 50 2T 13-16, AEROX R 50 2T 99-00, BW'S 50 2T 97-16, BW'S BUMP 50 2T 97-98, BW'S EASY 50 2T 13-13, BW'S NAKED 50 2T 03-04, BW'S NAKED 50 2T 09-16, BW'S NEXT GENERATION 50 2T 97-06, BW'S ORIGINAL 50 2T 99-01, BW'S ORIGINAL EURO 2 50 2T 03-03, JOG R 50 2T 02-02, JOG R EURO2 50 2T 02-02, JOG R EURO2 50 2T 06-15, JOG R LC 50 2T 02-15, NEO'S 50 2T 97-02, NEO'S 50 2T 04-16, NEO'S EASY 50 2T 13-13, NEO'S EURO 2 50 2T 02-02, RS SPY 50 2T 95-98, SLIDER 50 2T 00-02, WHY 50 2T 98-05, WHY EURO 2 50 2T 03-05, ZUMA 50 2T 97-01

◀ cod. **9935340** **MITSUBOSHI**
Cinghia di trasmissione per motori scooter 50 cc Minarelli/Yamaha tipo orizzontale corto

RIFERIMENTO ORIGINALE

Aprilia	AP8206818
---------	-----------

Yamaha	3WF176410000
--------	--------------

APPLICABILITÀ: SCOOTER 50 cc - ATV QUAD

APRILIA SONIC 50 2T 98-07, SONIC GP 50 2T 98-08

DINLI HELIX DL603 50 2T 07-13, HELIX DL603 90 50 2T 07-13, T-REX 50 2T 07-13

E-TON VIPER RXL 50 2T 06-06

LAVERDA QUASAR 50 2T 02-04

MALAGUTI F10 50 2T 92-00, F10 EURO 2 50 2T 02-06, F10 EURO 2 2,3 50 2T 03-04, F10 RESTYLING EURO 2 50 2T 06-06, YESTERDAY 50 2T 97-00

MBK EVOLIS 50 2T 92-95, FIZZ 50 2T 94-95, FORTE 50 2T 94-96

YAMAHA AXIS 50 2T 95-96, BREEZE 50 2T 94-95, CRZ 50 2T 91-95, JOG 50 2T 92-01, ZEST 50 2T 95-92

◀ cod. **9935370** **MITSUBOSHI**
Cinghia di trasmissione per motori scooter 50 cc Peugeot

RIFERIMENTO ORIGINALE

Peugeot	776648
---------	--------

APPLICABILITÀ

PEUGEOT KISBEE 50 2T 00-00, LUDIX 50 2T 90-02

SCOOTER 50 cc

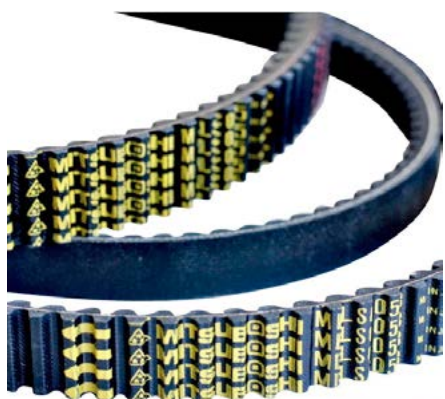

◀ cod. **9935410** **MITSUBISHI**
Cinghia di trasmissione per motori scooter 50 cc Peugeot

APPLICABILITÀ
Peugeot E-Vivacity (EC-45 km/H)

◀ cod. **9935420** **MITSUBISHI**
Cinghia di trasmissione per motori scooter 50 cc Piaggio

RIFERIMENTO ORIGINALE
Piaggio 82712R

APPLICABILITÀ

APRILIA SCARABEO 2T 50 2T 14-14, SCARABEO 2T EU2 MOTORE PIAGGIO 50 2T 10-12, SCARABEO 2T NET 50 2T 09-10, SCARABEO 4T 50 4T 02-06, SCARABEO 4T 4V 50 4T-4V 10-12, SCARABEO 4T 4V 50 4T-4V 14-14, SCARABEO 4T 4V NET 50 4T-4V 09-10, SCARABEO 4T RESTYLING EU3 50 4T 06-09, SCARABEO QUATTRO 50 4T-4V 09-09, SCARABEO STREET 50 2T 05-06, SCARABEO STREET 2T RESTYLING 50 2T 06-09, SPORT CITY ONE 2T 50 2T 08-11, SPORT CITY ONE 4T 50 4T 08-10, SR MOTARD 50 2T 12-14, SR MOTARD 4T 4V 50 4T-4V 13-14

DERBI BOULEVARD 2T 50 2T 09-14, SONAR 2T 50 2T 09-09, VARIANT SPORT 2T 50 2T 12-12

GILERA DNA 50 2T 00-02, DNA 50 2T 05-07, DNA GP EXPERIENCE 50 2T 03-04

PEUGEOT E-VIVACITY (EC-45 KM/H) 50 16-16

PIAGGIO FLY 2T 50 2T 05-07, FLY 2T 50 2T 10-11, LIBERTY 50 2T 97-05, LIBERTY 2T 50 2T 06-08, LIBERTY 2T PTT EU2 50 2T 04-05, LIBERTY 2T RST 50 2T 04-04, LIBERTY 2T SPORT 50 2T 06-08, LIBERTY 4T 50 4T 00-02, LIBERTY 4T 50 4T 05-08, LIBERTY 4T 3V 25 KM/H 50 4T-3V 16-16, LIBERTY 4T 3V IE 50 4T-3V 15-17, LIBERTY 4T 3V IE E4 50 4T-3V 17-18, LIBERTY 4T DELIVERY - SINGLE 50 4T 10-14, LIBERTY 4T DELIVERY TNT 50 4T 09-09, LIBERTY 4T IGET CORPORATE E4 50 4T-3V 18-18, LIBERTY 4T PTT (DEU) 50 4T 07-12, LIBERTY 4T PTT - DOUBLE - NEXIVE 50 4T 09-17,

LIBERTY 4T RST 50 4T 04-04, LIBERTY 4T SPORT 50 4T 06-08, LIBERTY IGET 4T 3V 25KM/H 50 4T-3V 16-16, LIBERTY IGET 4T 3V IE 50 4T-3V 15-17, LIBERTY IGET 4T 3V IE E4 EMEA 50 4T-3V 17-18, LIBERTY IGET 4T 3V IE E4 EMEA 25KM/H 50 4T-3V 18-18, LIBERTY MOC 2T & ELLE 50 2T 09-13, LIBERTY MOC 4T & ELLE 50 4T 09-16, TYPHOON 2T E2 50 2T 10-12, TYPHOON 2T E3 CH 50 2T 11-11, TYPHOON 2T EURO4 50 4T-3V 18-18

◀ cod. **9935480** **MITSUBISHI**
Cinghia di trasmissione per motori scooter 50 cc Piaggio

RIFERIMENTO ORIGINALE
Piaggio 842907

APPLICABILITÀ
DERBI ATLANTIS 4T 50 4T 04-06, ATLANTIS 4T EU2 50 4T 07-07, BOULEVARD 4T EU2 25KM/H 50 4T 09-09

PIAGGIO FLY 4T 50 4T 05-07, FLY 4T & 25-30 KM/H 50 4T 08-11, FLY 4T 2V 50 4T 13-15, FLY 4T 2V 25-30KM/H 50 4T 12-17, FLY 4T 4V 50 4T-4V 12-13, FLY 4T MOTORE CHN 50 4T 06-07, VESPA PRIMAVERA 4T 4V 50 4T-4V 13-17, VESPA SPRINT 4T 4V 50 4T-4V 14-17

◀ cod. **9935570** **MITSUBISHI**
Cinghia di trasmissione per motori scooter 50 cc Peugeot

RIFERIMENTO ORIGINALE
Peugeot 729171

APPLICABILITÀ
PEUGEOT BUXY 50 2T 90-02, BUXY RS 50 2T 90-02, ELYSEO 50 2T 90-02, JET FORCE 50 2T 90-02, LUDIX 50 2T 90-02, SPEEDAKE 50 2T 90-02, SPEEDFIGHT 50 2T 97-04, SPEEDFIGHT LC 50 2T 97-04, SQUAB 50 2T 90-02, TREKKER 50 2T 90-02, VIVACITY 50 2T 90-02, X-FIGHT 50 2T 00-02

◀ cod. **9935590** **MITSUBISHI**
Cinghia di trasmissione per motori scooter 50 cc Minarelli/Yamaha

RIFERIMENTO ORIGINALE
Yamaha 5C3-E7641-00

APPLICABILITÀ
YAMAHA GIGGLE 50 4T-3V 08-08

◀ cod. **9935600** **MITSUBISHI**
Cinghia di trasmissione per motori scooter 50 cc Minarelli/Yamaha

RIFERIMENTO ORIGINALE
Yamaha 5C3-E7641-00

APPLICABILITÀ
YAMAHA NEO'S 4 50 4T-3V 09-15

SCOOTER 50 cc

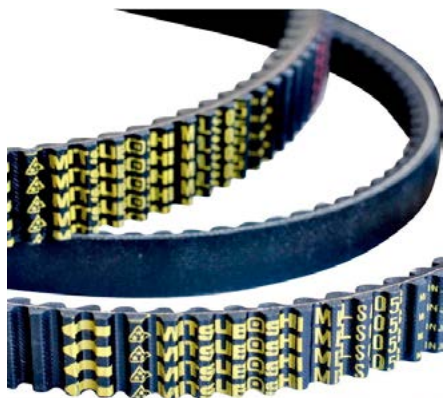

◀ cod. **9935800**  **MITSUBOSHI**
Cinghia di trasmissione per motori scooter 50 cc Piaggio

RIFERIMENTO ORIGINALE

Benelli	R030424102000
Garelli	GA06570
Garelli	GA02165
Gilera	430728

Keeway	24107B01F000
Malaguti	59015000
Piaggio	430728

APPLICABILITÀ: SCOOTER 50 CC - ATV QUAD

BENELLI PEPE 50 2T 10-10, PEPE LX 50 2T 07-09, PEPE OLD 50 2T 07-09, PEPE OLD 50 2T 11-11, QUATTRONONEX 50 2T 08-11

CPI ARAGON 50 2T 03-03, HUSSAR 50 2T 03-03, OLIVER 50 2T 03-03, POP CORN 50 2T 03-03

EXPLORER CRACKER 50 2T 03-03

GARELLI TIESSE 2T 50 2T 08-08, VIP 50 4T 06-06

GILERA STORM 50 2T 94-95, TYPHOON 50 2T 94-97, TYPHOON X 50 2T 98-99

HUPPER MONTECARLO 30 50 2T 09-09

KEEWAY ATV EC2 50 2T 06-06, ATV OFF ROAD 50 2T 07-07, F-ACT 50 2T 07-08, FLASH 50 2T 07-08, FOCUS 50 2T 06-06, GOCCIA 50 2T 09-09, HURRICANE 50 2T 06-08, MATRIX 50 2T 06-08, PIXEL EURO 2 50 2T 09-12, RY8 50 2T 08-08

MALAGUTI F10 AC WAP 50 2T 08-08, F12 R PHANTOM AC 50 2T 07-08

PIAGGIO FREE 50 2T 92-94, FREE FL 50 2T 95-02, NRG 50 2T 94-96, NRG RST MC2 50 2T 96-98, NTT 50 2T 95-96

◀ cod. **9935810**  **MITSUBOSHI**
Cinghia di trasmissione per motori scooter 50 cc Piaggio

RIFERIMENTO ORIGINALE

Piaggio	431190
---------	--------

APPLICABILITÀ

GILERA EASY MOVING 50 2T 95-96

PIAGGIO QUARTZ 50 2T 92-96, SFERA MAQUILLAGE 2 50 2T 94-94, SFERA RST 50 2T 95-97, VESPA ET2 50 2T 97-98, ZIP 50 2T 95-96, ZIP BIMODALE 50 2T 94-97, ZIP FAST RIDER 50 2T 93-94, ZIP FAST RIDER RST 50 2T 96-97, ZIP RST 50 2T 96-99, ZIP SP 50 2T 96-00

◀ cod. **9935820**  **MITSUBOSHI**
Cinghia di trasmissione per motori scooter 50 cc Aprilia

RIFERIMENTO ORIGINALE

Aprilia	AP2MCA000014
---------	--------------

APPLICABILITÀ

APRILIA HABANA-MOJITO CUSTOM 50 2T 99-03, HABANA-MOJITO RETRO' 50 2T 99-03, SCARABEO DITECH 50 2T-IE 01-04, SR DITECH EU2 50 2T-IE 02-04, SR H2O DITECH 50 2T-IE 00-04, SR R FACTORY MOTORE APRILIA 50 2T-IE 05-05

SUZUKI ESTILETE UF 50 2T 00-00, KATANA K1-K4 50 2T 01-04, KATANA V-Y 50 2T 97-00, ZILLION UX 50 2T 99-99

SYM SYMPHONY EURO 2 50 4T 09-09

◀ cod. **9935830**  **MITSUBOSHI**
Cinghia di trasmissione per motori scooter 50 cc Piaggio

RIFERIMENTO ORIGINALE

Piaggio	436864
---------	--------

APPLICABILITÀ

APRILIA MOJITO CUSTOM 2T MOTORE PIAGGIO 50 2T 04-10, SR CARBURATORE 50 2T 14-14, SR R 50 2T 04-09, SR R FACTORY CARBURATORE 50 2T 10-14, SR R FACTORY IE 50 2T 10-14, SR STREET CARBURATORE 50 2T 03-12

DERBI ATLANTIS 2T 50 2T 10-10, ATLANTIS 2T EU2 50 2T 07-09, ATLANTIS O2 50 2T 02-02, ATLANTIS O2 BULLET 50 2T 03-05, ATLANTIS O2 CITY 50 2T 04-06, ATLANTIS O2 RED BULLET 50 2T 03-03, ATLANTIS O2 TWO CHIC 50 2T 05-05, GP1 50 2T 01-03, GP1 EU 2 50 2T 05-05, GP1 OPEN EU2 50 2T 06-09, GP1 RACE EU2 50 2T 05-07

GILERA ICE 50 2T 01-05, RUNNER 50 2T 97-00, RUNNER POGGIALI 50 2T 02-02, RUNNER PURE JET 50 2T-IE 02-04, RUNNER SP 50 2T 02-07, RUNNER SP 50 2T 10-12, RUNNER SP SPECIAL EDITION 50 2T 07-07, RUNNER SP ST & SIMONCELLI 50 2T 08-09, STALKER 50 2T 97-11, STALKER NAKED 50 2T 08-08, STALKER SPECIAL EDITION 50 2T 07-08, STORM EURO 2 50 2T 07-07, TYPHOON XR 50 2T 00-00

PIAGGIO DIESIS 50 2T 01-01, FREE DELIVERY 50 2T 00-01, NRG MC3 50 2T 01-04, NRG POWER DD 50 2T 05-17, NRG POWER DD SERIE SPECIALE 50 2T 07-12, NRG POWER DT 50 2T 06-15, NRG POWER DT SERIE SPECIALE 50 2T 07-08, NRG PUREJET 50 2T-IE 02-04, TYPHOON 50 2T 01-11

◀ cod. **9935840**  **MITSUBOSHI**
Cinghia di trasmissione per motori scooter 50 cc Piaggio

RIFERIMENTO ORIGINALE

Piaggio	82645R
---------	--------

APPLICABILITÀ

PIAGGIO VESPA ET2 50 2T 98-05, VESPA ET2 INIEZIONE 50 2T 97-00, VESPA ET4 50 4T 00-05, VESPA LX 2T 50 2T 05-13, VESPA LX 2T TOURING & 30KM 50 2T 10-13, VESPA LX 4T 50 4T 05-09, VESPA LX 4T 4V 50 4T-4V 09-13, VESPA LX 4T 4V TOURING 50 4T-4V 10-13, VESPA LXV 2T 50 2T 06-09, VESPA LXV 2T NAVY 50 2T 08-08, VESPA S 2T & COLLEGE 50 2T 07-12, VESPA S 4T 4V & COLLEGE 50 4T-4V 08-12, ZIP 2T 50 2T 08-13, ZIP 4T 50 4T 00-13, ZIP LC 50 2T 00-04, ZIP SP 50 2T 01-04, ZIP SP EURO 2 50 2T 06-13, ZIP 4T 100 4T 06-10

SCOOTER 50 cc

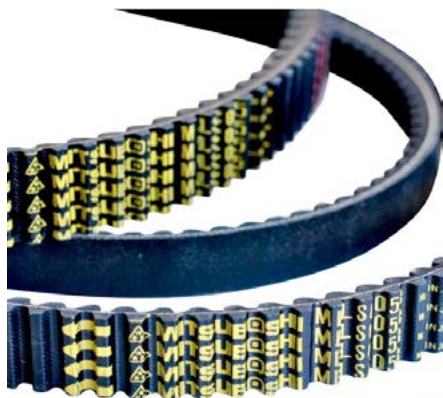

◀ cod. **9935850**  **MITSUBOSHI**
Cinghia Honda SH 50 cc H '84-'95

APPLICABILITÀ

Honda SH 50 2T 84-89

◀ cod. **9935860**  **MITSUBOSHI**
Cinghia Honda NH 50 cc LEAD '87-'95

APPLICABILITÀ

Honda LEAD 50 2T 89-90

◀ cod. **9935950**  **MITSUBOSHI**
Cinghia Suzuki Katana 50 cc

APPLICABILITÀ

Suzuki AP 50 2T 94-97, KATANA K1-K4 50 2T 01-04, KATANA V-Y 50 2T 97-00

SCOOTER 100 cc

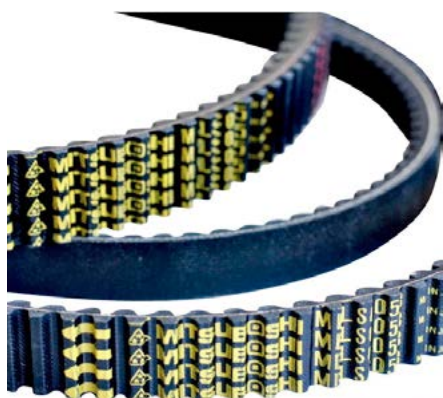

◀ cod. **9935200**  **MITSUBOSHI**
Cinghia di trasmissione per motori scooter 100 cc 2T Aprilia

RIFERIMENTO ORIGINALE

Aprilia	AP8510802	Yamaha	5FA176410
---------	-----------	--------	-----------

APPLICABILITÀ

APRILIA SCARABEO (YAMAHA) 100 2T 00-00
YAMAHA AEROX 100 2T 00-02, BW'S 100 2T 99-01, NEO'S 100 2T 99-02

◀ cod. **9935210**  **MITSUBOSHI**
Cinghia di trasmissione per motori scooter 100 cc 4T Aprilia

RIFERIMENTO ORIGINALE

Aprilia	82646R
---------	--------

APPLICABILITÀ

APRILIA SCARABEO 4T 100 4T 01-05, SCARABEO 4T 100 4T 10-12, SCARABEO 4T 100 4T 14-14, SCARABEO 4T NET 100 4T 09-09, SCARABEO 4T NET EU3 100 4T 10-10, SCARABEO 4T RESTYLING 100 4T 06-09

◀ cod. **9935440**  **MITSUBOSHI**
Cinghia di trasmissione per motori scooter 100 cc 4T Piaggio

RIFERIMENTO ORIGINALE

Piaggio	829484
---------	--------

APPLICABILITÀ

DERBI ATLANTIS 4T 100 4T 04-06, BOULEVARD 4T 100 4T 10-11 **PIAGGIO** FLY 100 4T 06-14, FREE 100 4T 02-03

MAXI SCOOTER

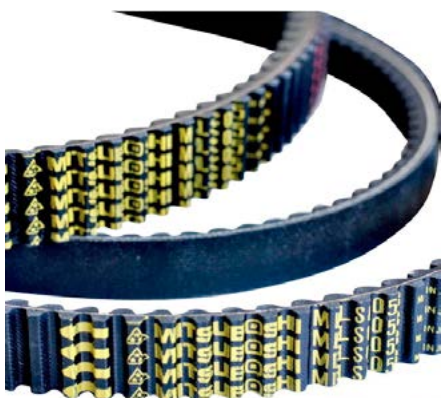

◀ cod. **9915220** **BANDO**

◀ cod. **9935660** **MITSUBISHI**

Cinghia di trasmissione per motori scooter 125/150 cc Aprilia - Rotax

RIFERIMENTO ORIGINALE

Aprilia	AP0280102
Beta	3610750000

Kymco	00127985
Malaguti	51700300

APPLICABILITÀ

APRILIA LEONARDO 125 4T 96-02, LEONARDO ST 125 4T 03-04, SCARABEO 125 4T 99-03, LEONARDO 150 4T 96-02, SCARABEO 150 4T 99-03

BETA EIKON 125 4T 00-02, EIKON 150 4T 00-02

BMW C1 125 4T 00-03, C1 200 4T 02-03

KYMCO B&W 125 4T 00-00, B&W EU2 125 4T 03-04, DINK 125 4T 97-98, DINK CLASSIC 125 4T 02-02, DINK CLASSIC EU2 125 4T 03-03, DINK EU3 125 4T 06-07, DINK LX 125 4T 98-00, GRAND DINK 125 4T 01-02, GRAND DINK EU2 125 4T 03-04, B&W 150 4T 00-00, B&W EU2 150 4T 03-04, DINK 150 4T 97-98, DINK CLASSIC 150 4T 02-02, DINK CLASSIC EU2 150 4T 03-03, DINK LX 150 4T 98-00, GRAND DINK 150 4T 01-02, GRAND DINK EU2 150 4T 03-04

MALAGUTI F18 WARRIOR 125 4T 00-02, F18 WARRIOR 150 4T 00-02

◀ cod. **9915340** **BANDO**

◀ cod. **9935780** **MITSUBISHI**

Cinghia di trasmissione per motori scooter 180 cc Piaggio

RIFERIMENTO ORIGINALE

Piaggio	484497
---------	--------

Gilera	484497
--------	--------

APPLICABILITÀ

Gilera Runner FXR 180 180 2T 97-02

Piaggio Hexagon LXT180 180 2T 98-00

◀ cod. **9915350** **BANDO**

◀ cod. **9935670** **MITSUBISHI**

Cinghia di trasmissione per motori scooter 125/150 cc Piaggio

RIFERIMENTO ORIGINALE

Piaggio	434812
---------	--------

Gilera	434812
--------	--------

APPLICABILITÀ

APRILIA SR 125 2T 99-01, SR 150 2T 99-01

GILERA RUNNER FX 125 2T 97-02, TYPHOON 125 2T 95-98, TYPHOON X-XR 125 2T 99-00

PIAGGIO SKIPPER LX 125 2T 98-99, HEXAGON 150 2T 94-97, SKIPPER LX 150 2T 98-99, SKYPPER 150 2T 94-97

◀ cod. **9915360** **BANDO**

◀ cod. **9935680** **MITSUBISHI**

Cinghia di trasmissione per motori scooter 125 cc Piaggio

RIFERIMENTO ORIGINALE

Piaggio	431258
---------	--------

APPLICABILITÀ

Piaggio Hexagon 125 125 2T 94-97, Hexagon LX 125 125 2T 98-99, Skypper 125 125 2T 94-97

◀ cod. **9915370** **BANDO**

◀ cod. **9935690** **MITSUBISHI**

Cinghia di trasmissione per motori scooter 125 cc Piaggio

RIFERIMENTO ORIGINALE

Piaggio	478547
---------	--------

APPLICABILITÀ

Piaggio Sfera 125 4T 95-97, Vespa ET4 125 125 4T 96-98

MAXI SCOOTER

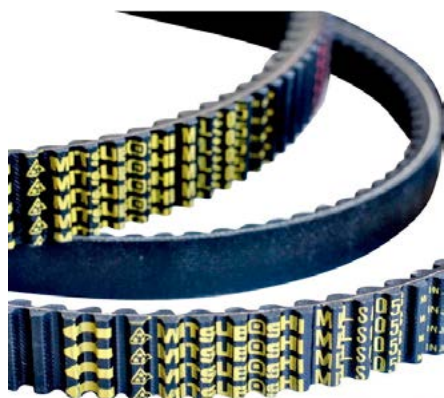

◀ cod. **9915380** **BANDO**

◀ cod. **9935700** **MITSUBISHI**

Cinghia di trasmissione per motori scooter 125/150/180 cc Minarelli/Yamaha

RIFERIMENTO ORIGINALE

Benelli	R16140631A0
Malaguti	71700900
Yamaha	5DS176410000
MBK	5DS176410000

Yamaha	5NSE76411000
Yamaha	5XME76410000
Aprilia	AP8550130
Italjet	4871702090

APPLICABILITÀ

BENELLI VELVET 125 4T 99-01, VELVET TOURING 125 4T 02-03, VELVET 150 4T 99-01, VELVET TOURING 150 4T 02-03

ITALJET JUPITER 125 4T 01-02, MILLENNIUM 125 4T 00-02, JUPITER 150 4T 01-02, MILLENNIUM 150 4T 00-02

MALAGUTI MADISON 125 4T 99-01, MADISON R RESTYLING 125 4T 02-02, MADISON R RESTYLING EU2 125 4T 03-04, PHANTOM MAX 125 4T 03-03, MADISON T 150 4T 99-01

MBK DOODO 125 4T 00-00, SKYLINER 125 4T 98-02, SKYLINER E 125 4T 03-03, THUNDER 125 4T 01-02, DOODO 150 4T 01-02, SKYLINER 150 4T 00-02, THUNDER 150 4T 01-02

YAMAHA MAJESTY 125 4T 98-00, MAJESTY (5NR1) 125 4T 01-01, MAJESTY (5NR8) 125 4T 02-02, MAJESTY E 125 4T 03-09, MAXSTER 125 4T 01-02, TEO'S 125 4T 00-00, MAJESTY 150 4T 00-00, MAJESTY (5NS1) 150 4T 01-01, MAJESTY (5NS6) 150 4T 02-02, MAXSTER 150 4T 01-02, TEO'S 150 4T 01-02, MAJESTY E 180 4T 03-06

◀ cod. **9915410** **BANDO**

Cinghia di trasmissione per motori scooter 250 cc Honda

RIFERIMENTO ORIGINALE

Honda	23100KM1671
-------	-------------

Piaggio	495158
---------	--------

APPLICABILITÀ

HONDA CN SPAZIO/HELIX 250 4T 86-99

PIAGGIO HEXAGON GT 250 4T 98-00

◀ cod. **9915640** **BANDO**

Cinghia di trasmissione per motori scooter 125/150 cc Kymco

RIFERIMENTO ORIGINALE

Kymco	00127785
-------	----------

APPLICABILITÀ

Kymco Heroism 125 125 4T 95-97, Movie 125 125 4T 99-00, Vivio 125 125 4T 00-00, Heroism 150 150 4T 95-97, Vivio 150 150 4T 00-00

◀ cod. **9915790** **BANDO**

Cinghia di trasmissione per motori scooter 250 cc Suzuki

RIFERIMENTO ORIGINALE

Suzuki	27601-14F11-000
--------	-----------------

APPLICABILITÀ

SUZUKI AN BURGMAN K1/K2 250 4T 01-02, AN BURGMAN K3/K6 250 4T 03-06

◀ cod. **9915800** **BANDO**

◀ cod. **9935710** **MITSUBISHI**

Cinghia di trasmissione per motori scooter 250 cc Yamaha

RIFERIMENTO ORIGINALE

Aprilia	AP8122639
Benelli	R16040171A0
Malaguti	91700200

Yamaha	5CG176410000
MBK	5CG176410000

APPLICABILITÀ

APRILIA LEONARDO 250 4T 99-04, LEONARDO ST 250 4T 01-01, LEONARDO 300 4T 02-04

BENELLI VELVET 250 4T 99-03

ITALJET JUPITER 250 4T 00-02

MALAGUTI MADISON S 250 4T 99-01

MBK SKYLINER 250 4T 00-03, SKYLINER ABS 250 4T 03-03

YAMAHA MAJESTY 250 4T 96-03, MAJESTY ABS 250 4T 03-03, MAJESTY DX 250 4T 98-99

MAXI SCOOTER

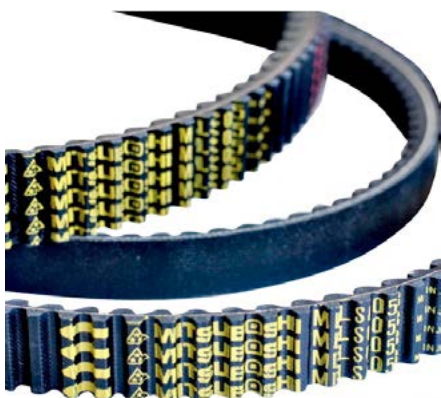

◀ cod. **9917990** **BANDO**

◀ cod. **9935720** **MITSUBISHI**
Cinghia di trasmissione per motori scooter 250 cc Honda

RIFERIMENTO ORIGINALE

Honda	23100KFG003
Honda	23100KTB003

Piaggio	496304
---------	--------

APPLICABILITÀ

HONDA FORESIGHT [FES] 250 4T 98-99, FORESIGHT [FES] D.D. 250 4T 00-05, FORZA [NSS] 250 4T-2V 02-07, JAZZ ES REFLEX [NSS] 250 4T-2V 01-04, JAZZ REFLEX [NSS] 250 4T-2V 01-01

PIAGGIO X9 250 4T 00-01

◀ cod. **9918000** **BANDO**

Cinghia di trasmissione per motori scooter 125/150 cc Honda

RIFERIMENTO ORIGINALE

Honda	23100KFF901
-------	-------------

APPLICABILITÀ

HONDA PANTHEON [FES] 125 2T 98-02, PANTHEON [FES] 150 2T 98-02

◀ cod. **9920430** **BANDO**

◀ cod. **9935730** **MITSUBISHI**
Cinghia di trasmissione per motori scooter 400 cc Suzuki

RIFERIMENTO ORIGINALE

Suzuki	27601-15F10-000
--------	-----------------

APPLICABILITÀ

Suzuki AN Burgman 400 K3/K6 400 4T 03-06

◀ cod. **9922420**

Cinghia di trasmissione per motori scooter 250 cc Kymco

RIFERIMENTO ORIGINALE

Kymco	00127998
-------	----------

APPLICABILITÀ

KYMCO B&W 250 4T 00-00, B&W EU2 250 4T 03-03, GRAND DINK 250 4T 01-02, GRAND DINK EU2 250 4T 03-04, YUP 250 4T 03-03

◀ cod. **9923140**

◀ cod. **9935770** **MITSUBISHI**
Cinghia di trasmissione per motori scooter 125/150 cc Honda

RIFERIMENTO ORIGINALE

Honda	23100KGF901
Honda	23100KGG911

Keeway	200013160000
Malaguti	65044800

APPLICABILITÀ

HONDA @ [NES] 125 4T 00-06, BALLI 125 4T 96-01, DYLAN [SES] 125 4T 02-04, PANTHEON IE [FES] 125 4T-2V 03-05, PS I [PES] 125 4T 06-10, SH 125 4T-2V 01-04, SH IE SCOOPI 125 4T-2V 05-12, SILVER WING [FES] 125 4T-2V 07-12, @ [NES] 150 4T 00-06, BALLI 150 4T 96-01, DYLAN [SES] 150 4T 02-04, PANTHEON IE [FES] 150 4T-2V 03-05, PS I [PES] 150 4T 06-10, SH 150 4T-2V 01-04, SH IE SCOOPI 150 4T 05-12, SILVER WING [FES] 150 4T-2V 07-12

KEEWAY OUTLOOK 125 4T 07-08, OUTLOOK DR 125 4T 07-11, SILVERBLADE 4T 125 4T 11-11, OUTLOOK 150 4T 07-08, OUTLOOK DR 150 4T 07-11

MALAGUTI BLOG 125 4T 11-11, BLOG IE 125 4T 09-10, CENTRO IE EU3 125 4T 08-09, CENTRO SL 125 4T 11-11, CENTRO SL IE EU3 125 4T 09-10, BLOG 160 4T 11-11, BLOG IE 160 4T 09-10, CENTRO IE EU3 160 4T 08-09, CENTRO SL 160 4T 11-11, CENTRO SL IE EU3 160 4T 09-10

WT MOTORS ATENE 150 4T 08-10

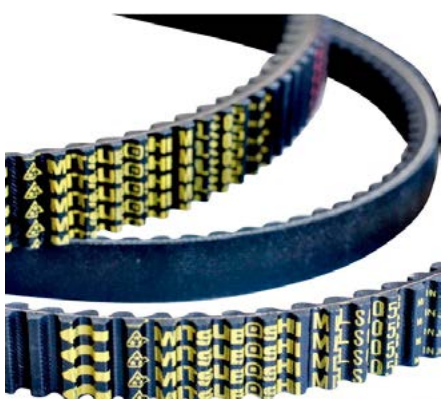

MAXI SCOOTER



◀ cod. **9925280** **MITSUBISHI**
Cinghia di trasmissione per motori scooter 125 cc Minarelli/Yamaha

RIFERIMENTO ORIGINALE

Yamaha	1B9E76410000	MBK	1B9E76410000
--------	--------------	-----	--------------

APPLICABILITÀ

MBK	CITYLINER EU3 125 4T-4V 08-10, SKYCRUISER 125 4T-4V 07-07	YAMAHA	X-CITY EU3 125 4T-4V 08-11, X-MAX R 125 4T-4V 06-16, X-MAX R ABS 125 4T-4V 11-11, X-MAX RA ABS 125 4T-4V 13-16
------------	---	---------------	--

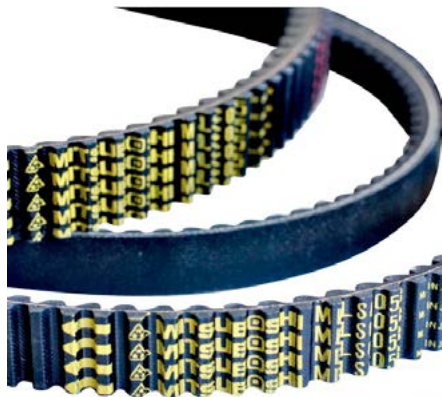

◀ cod. **9925600** **MITSUBISHI**
Cinghia di trasmissione per motori scooter 250/300 cc Minarelli/Yamaha

RIFERIMENTO ORIGINALE

Malaguti	71701100	Malaguti	71701100
Yamaha	5SEE76410200		

APPLICABILITÀ

MALAGUTI	PASSWORD 250 4T 05-06, PASSWORD EU3 250 4T 07-08	YAMAHA	X-CITY 250 4T 07-15, X-MAX 250 4T 05-16, X-MAX ABS 250 4T 11-12, X-MAX ABS 250 4T 14-15, X-MAX BLACK 250 4T 09-09, X-MAX SPORT 250 4T 11-12, VERSITY 300 4T 03-06
MBK	KILIBRE 300 4T 03-06		



◀ cod. **9925850** **BANDO**
◀ cod. **9935790** **MITSUBISHI**
Cinghia di trasmissione per motori scooter 125/250 cc Sym

RIFERIMENTO ORIGINALE

Sym	1B01HMA01
-----	-----------

APPLICABILITÀ

SYM	GTS 250 4T-4V 07-08, JOYMAX 250 4T-4V 05-07, JOYMAX EU3 1250 4T-4V 07-08
------------	--

◀ cod. **9925860** **BANDO**
Cinghia di trasmissione per motori scooter 200 cc Sym

RIFERIMENTO ORIGINALE

Sym	1B01HHA01
-----	-----------

APPLICABILITÀ

SYM	HD EU2 200 4T-4V 03-04, HD EU3 1200 4T-4V 07-07, HD EVO EU2 200 4T-4V 05-06, HD EVO EU3 1200 4T-4V 07-07, HD EVO I EU3 200 4T-4V 10-10, HD EVO I TAMBURO EU3 200 4T-4V 08-09, HD2 1200 4T-4V 11-11
------------	--

◀ cod. **9926420** **BANDO**
Cinghia di trasmissione per motori scooter 125/200 cc Kymco

RIFERIMENTO ORIGINALE

Kymco	00127099	Sym	1B01KN701
-------	----------	-----	-----------

APPLICABILITÀ

KYMCO	DINK I EU3 200 4T 06-07
SYM	FIDDLE II 125 4T 08-09, SYMPLY 125 4T 07-08, SYMPLY II 125 4T 09-10

MAXI SCOOTER

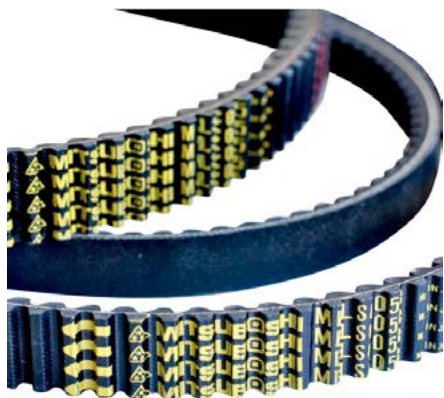

◀ cod. **9926430** **BANDO**

◀ cod. **9935740** **MITSUBOSHI**

Cinghia di trasmissione per motori scooter 125/150/200 cc Kymco

RIFERIMENTO ORIGINALE

Kymco	00127541
Kymco	00127542

Malaguti	51700600
Malaguti	51700700

APPLICABILITÀ

KYMCO AGILITY 125 4T 06-06, AGILITY CARRY 125 4T 11-11, AGILITY EU3 125 4T 06-08, AGILITY PLUS 125 4T 14-14, AGILITY PLUS E4 125 4T 16-16, AGILITY R16 125 4T 08-09, AGILITY R16 125 4T 12-12, AGILITY RS 125 4T 09-09, LIKE 125 4T 09-09, LIKE LX 125 4T 12-12, MOVIE EU3 125 4T 06-07, MOVIE XL 125 4T 01-01, MOVIE XL EU2 125 4T 03-04, PEOPLE 125 4T 99-00, PEOPLE EU2 125 4T 03-03, PEOPLE EU3 125 4T 07-08, PEOPLE EU3 125 4T 11-11, PEOPLE ONE E4 125 4T 16-16, PEOPLE ONE I 125 4T 13-13, PEOPLE ONE I DD 125 4T 15-15, PEOPLE S 125 4T 05-05, PEOPLE S DD EU3 125 4T 07-08, SUPER 8 125 4T 08-09, AGILITY R16 150 4T 08-09, MOVIE EU3 150 4T 06-07, MOVIE XL 150 4T 01-01, MOVIE XL EU2 150 4T 03-04, PEOPLE 150 4T 99-00, PEOPLE EU2 150 4T 03-03

◀ cod. **9927480** **MITSUBOSHI**

Cinghia di trasmissione per motori scooter 300 cc Honda

RIFERIMENTO ORIGINALE

Honda	23100KTW901
-------	-------------

APPLICABILITÀ

HONDA FORZA 300 4T 4V 13-17, SH IE SCOOPY 300 4T-4V 07-19

◀ cod. **9927490** **MITSUBOSHI**

Cinghia di trasmissione per motori scooter 400 cc Honda

RIFERIMENTO ORIGINALE

Honda	23100MEF003
-------	-------------

APPLICABILITÀ

HONDA SILVER WING [FJS] 400 4T 06-08, SW-T [FJS] 400 4T 09-13

◀ cod. **9927500** **MITSUBOSHI**

Cinghia di trasmissione per motori scooter 125/150 cc Suzuki

RIFERIMENTO ORIGINALE

Suzuki	27601-21F11-000
--------	-----------------

APPLICABILITÀ

SUZUKI EPICURO 125 4T 99-01, UH BURGMAN K2/K6 125 4T 02-06, EPICURO 150 4T 99-01, UH BURGMAN K2/K6 150 4T 02-06

◀ cod. **9927510** **MITSUBOSHI**

Cinghia di trasmissione per motori scooter 125 cc Suzuki

RIFERIMENTO ORIGINALE

Suzuki	27601-03H00-000
--------	-----------------

APPLICABILITÀ

SUZUKI UH BURGMAN K7/L0 125 4T 07-10, UH BURGMAN L1 125 4T 11-11, UH BURGMAN L3 125 4T 13-13, UH BURGMAN L4 125 4T 14-14, UH BURGMAN L6 125 4T 16-16

MAXI SCOOTER

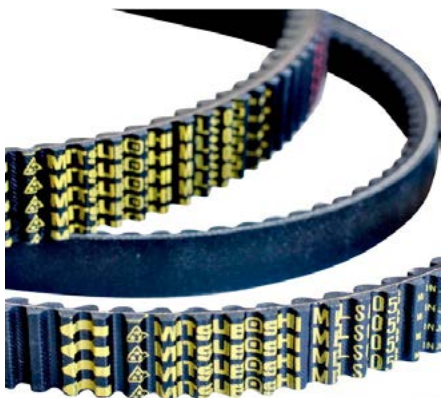

◀ cod. **9927520**  **MITSUBISHI**
Cinghia di trasmissione per motori scooter 200 cc Suzuki

RIFERIMENTO ORIGINALE

Suzuki	27601-14F30-000
--------	-----------------

APPLICABILITÀ

SUZUKI UH BURGMAN K7/LO 200 4T 07-10, UH BURGMAN L1 200 4T 11-12, UH BURGMAN L3 200 4T 13-13, UH BURGMAN L4 200 4T 14-14

◀ cod. **9927530**  **MITSUBISHI**
Cinghia di trasmissione per motori scooter 400 cc Yamaha

RIFERIMENTO ORIGINALE

Yamaha	SRU176410000
--------	--------------

APPLICABILITÀ

Yamaha Majesty 400 4T 04-06

◀ cod. **9927550**  **MITSUBISHI**
Cinghia di trasmissione per motori scooter 500 cc Minarelli/Yamaha

RIFERIMENTO ORIGINALE

Yamaha	5VU176410000
--------	--------------

APPLICABILITÀ

YAMAHA T-MAX 4BS 500 4T 09-11, T-MAX 4BS ABS 500 4T 08-11, T-MAX 5GJ 500 4T 01-03, T-MAX 5VU 500 4T 04-08, T-MAX 5VU ABS 500 4T 05-07, T-MAX 5VU BLACK MAX 500 4T 06-06, T-MAX 5VU BLACK MAX - NIGHT MAX 500 4T 07-07

◀ cod. **9927630**  **MITSUBISHI**
Cinghia di trasmissione per motori scooter 400/500 cc Piaggio

RIFERIMENTO ORIGINALE

Piaggio	832738
Piaggio	849090

Malaguti	41701600
----------	----------

APPLICABILITÀ

APRILIA ATLANTIC ARRECIFE 400 4T 05-08, ATLANTIC SPRINT 400 4T 05-08, SCARABEO LIGHT 400 4T 06-08, ATLANTIC ARRECIFE 500 4T 05-08, ATLANTIC SPRINT 500 4T 05-08, SCARABEO 500 4T 03-06, SCARABEO LIGHT 500 4T 06-08
GILERA NEXUS 500 4T 03-05, NEXUS EU3 500 4T 09-11
MALAGUTI SPIDER MAX GT 500 4T 04-05, SPIDER MAX GT EU3 500 4T 06-06, SPIDER MAX RS 500 4T 08-08

PEUGEOT GEOPOLIS IE EU3 400 4T 4V 90-02, SATELIS EU3 400 4T 07-12, GEOPOLIS IE EU3 500 4T 4V 90-02, SATELIS EU3 500 4T 90-02
PIAGGIO BEVERLY EU3 400 4T 06-07, BEVERLY TOURER EU3 400 4T 08-10, MP3 400 4T 07-08, MP3 IE LT TOURING 400 4T 11-11, MP3 IE LT/SPORT 400 4T 08-10, MP3 MIC 400 4T 08-10, MP3 RL TOURING 400 4T 11-11, X-EVO 400 4T 07-11, X8 EU3 400 4T 06-08, BEVERLY 500 4T 02-06, BEVERLY IE EU3 500 4T 06-08, X9 EVOLUTION 500 4T 03-07, X9 EVOLUTION ABS 500 4T 06-07

◀ cod. **9927640**  **MITSUBISHI**
Cinghia di trasmissione per motori scooter Piaggio Beverly 250 cc

RIFERIMENTO ORIGINALE

Piaggio	B013360
Aprilia	B013360

Derbi	B013360
-------	---------

APPLICABILITÀ

APRILIA SCARABEO 250 4T 04-06, SCARABEO LIGHT 250 4T 06-08, SPORT CITY CUBE 250 4T 08-12, SPORT CITY EU3 250 4T 06-08, SCARABEO LIGHT 300 4T 09-10, SPORT CITY CUBE 300 4T 08-10, SPORT CITY STREET 300 4T 4V 12-12
DERBI RAMBLA 250 4T 08-09, RAMBLA EU3 2VER 250 4T 08-08, RAMBLA 300 4T 10-11

PIAGGIO BEVERLY 250 4T 05-07, BEVERLY CRUISER 250 4T 07-09, BEVERLY EURO 3 MIC 250 4T 07-07, BEVERLY IE EU3 250 4T 06-08, BEVERLY RST 250 4T 04-05, BEVERLY SPORT 250 4T 06-08, BEVERLY TOURER EU3 250 4T 07-09, CARNABY 250 4T 08-09, BEVERLY RST 4T 4V IE EU3 300 4T 10-16, BEVERLY TOURER EU3 300 4T 09-10, CARNABY CRUISER 300 4T 09-12

MAXI SCOOTER

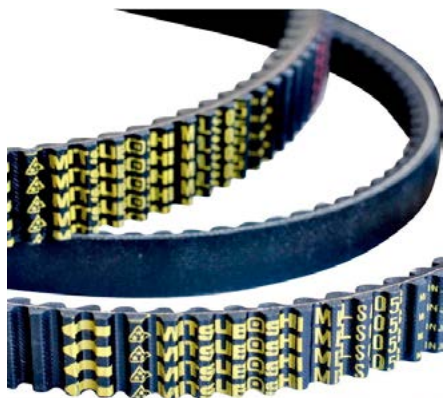

◀ cod. **9927650**  **MITSUBOSHI**
Cinghia di trasmissione per motori scooter 125/150 cc Piaggio

RIFERIMENTO ORIGINALE

Piaggio	841213
Benelli	R13440941A0
Aprilia	841213

Derbi	841213
Gilera	841213

APPLICABILITÀ

APRILIA ATLANTIC 125 4T 03-05, ATLANTIC ARRECIFE 125 4T 03-05, ATLANTIC EU3 125 4T 06-08, ATLANTIC EU3 125 4T 10-12, MOJITO 125 4T 03-08, SPORT CITY ONE 4T EU3 125 4T 08-11, SR MAX 125 4T 11-14, SR MOTARD 125 4T-2V 12-14, MOJITO 150 4T 03-07

BENELLI ADIVA 125 4T 01-02, ADIVA 150 4T 01-02

DERBI BOULEVARD 125 4T 02-04, BOULEVARD 4T EU3 125 4T 08-12, BOULEVARD EU2 125 4T 04-07, GP1 EU 2 125 4T 06-06, GP1 LOW SEAT EU3 125 4T 07-08, SONAR 4T 125 4T 09-11, VARIANT SPORT 4T EU3 125 4T 12-12, BOULEVARD 150 4T 02-04, BOULEVARD 4T E3 150 4T 10-10, BOULEVARD EU3 150 4T 04-07, SONAR 4T 150 4T 09-09

GILERA DNA 125 4T 01-01, NEXUS EU3 125 4T 07-08, NEXUS IE EU3 125 4T 08-10, RUNNER 4T ST EU3 125 4T 08-16, RUNNER VX 125 4T 00-06, RUNNER VX 4T EU3 125 4T 06-07, RUNNER VX RACE 125 4T 06-06, RUNNER VX SC 125 4T 06-07

PIAGGIO FLY 125 4T 05-07, FLY EU3 125 4T 07-11, HEXAGON GTX 125 4T 00-00, LIBERTY 125 4T 01-02, LIBERTY 4T 125 4T 06-07, LIBERTY 4T 2V EURO3 125 4T 09-12, LIBERTY 4T EU3 125 4T 06-08, LIBERTY 4T EU3 DELIVERY - TNT 125 4T 08-15, LIBERTY 4T SPORT EU3 125 4T 06-08, LIBERTY RST 125 4T 04-05, LIBERTY RST PTT 125 4T 05-11, LIBERTY SPORT 125 4T 06-06, MP3 125 4T 06-08, MP3 IBRIDO 125 4T 09-10, MP3 IE 125 4T 08-09, MP3 IE TOURING 125 4T 11-12, MP3 YOURBAN ERL 125 4T 11-13, SKYPPER 4T 125 4T 00-02, SUPER HEXAGON GTX 125 4T 01-02, TYPHOON 4T 2V E3 125 4T 10-11, VESPA ET4 125 4T 99-02, VESPA GRANTURISMO 125 4T 03-07, VESPA GRANTURISMO EU3 125 4T 06-07, VESPA GTS 4T IE SUPER 125 4T 09-16, VESPA GTS EU3 125 4T 07-12, VESPA GTV 125 4T 06-08, VESPA GTV 4T NAVY EU3 125 4T 08-08, VESPA LX 125 4T 05-06, VESPA LX 4T EU3 TOURING 125 4T 10-11, VESPA LX 4T FL 125 4T 09-09, VESPA LX EU3 125 4T 06-08, VESPA LX EU3 IE 125 4T 09-11, VESPA LXV 4T EU3 125 4T 06-09, VESPA LXV IE 4T 125 4T 10-13, VESPA LXV NAVY EU3 125 4T 07-08, VESPA S 4T EU3 125 4T 07-08, VESPA S 4T IE & COLLEGE 125 4T 09-11, X-EVO 125 4T 07-16, X7 EU3 125 4T 08-08, X7 EVO IE EU3 125 4T 09-10, X8 125 4T 04-06, X8 PREMIUM EU2 125 4T 06-06, X8 PREMIUM EU3 125 4T 06-07, X8 STREET EU2 125 4T 06-07, X9 125 4T 01-02, X9 EVOLUTION 125 4T 03-03, X9 EVOLUTION 125 4T 05-06, X9 EVOLUTION EU3 125 4T 07-07, ZIP 125 4T 00-02, FLY 150 4T 05-07, FLY EU3 150 4T 08-11, LIBERTY 150 4T 01-02, LIBERTY 4T EU3 150 4T 08-08, LIBERTY 4T SPORT EU3 150 4T 08-08, LIBERTY MOC 4T 150 4T 09-13, SKYPPER 4T 150 4T 00-02, VESPA ET4 150 4T 99-02, VESPA LX 150 4T 05-06, VESPA LX 4T FL 150 4T 09-09, VESPA LX EU3 150 4T 06-08, VESPA LX EU3 IE 150 4T 09-11, VESPA LX TOURING 150 4T 10-12, VESPA S 4T 150 4T 08-09, VESPA S 4T IE & COLLEGE 150 4T 09-12, X8 STREET EU2 150 4T 06-08

RENAULT FULLTIME 125 4T 02-03

◀ cod. **9927660**  **MITSUBOSHI**
Cinghia di trasmissione per motori scooter 400 cc Suzuki

RIFERIMENTO ORIGINALE

Suzuki	27601-05H00-000
--------	-----------------

APPLICABILITÀ

SUZUKI AN BURGMAN K7/L0 400 4T 07-10, AN BURGMAN L1 400 4T 11-11, AN BURGMAN L2 400 4T 12-12, AN BURGMAN L3 400 4T 13-13, AN BURGMAN L4 400 4T 14-14, AN BURGMAN L5 400 4T 15-15, AN BURGMAN L6 400 4T 16-16

◀ cod. **9928540**  **MITSUBOSHI**
Cinghia di trasmissione per motori scooter 125/250 cc Piaggio

RIFERIMENTO ORIGINALE

Piaggio	842009
Aprilia	842009

Derbi	842009
-------	--------

APPLICABILITÀ

APRILIA SCARABEO 125 4T 03-06, SCARABEO EU3 125 4T 06-07, SPORT CITY 125 4T 04-06, SPORT CITY CUBE 125 4T 08-10, SPORT CITY EU3 125 4T 06-08, SPORT CITY STREET 125 4T 12-12, SCARABEO 150 4T 04-06

DERBI RAMBLA 125 4T 08-09, RAMBLA EU3 2VER 125 4T 08-08

PIAGGIO BEVERLY 125 4T 01-03, BEVERLY EU3 125 4T 07-08, BEVERLY EURO 3 MIC 125 4T 07-07, BEVERLY EURO 3 SPORT 125 4T 07-08, BEVERLY RST 125 4T 04-07, BEVERLY RST 4T 4V IE EU3 125 4T 10-15, BEVERLY TOURER EU3 125 4T 07-10, CARNABY 125 4T 07-10, X10 4T 4V EU3 125 4T-4V 12-15

WT MOTORS MIAMI 250 4T 11-17

MAXI SCOOTER



◀ cod. **9929770**  **MITSUBOSHI**
Cinghia di trasmissione per motori scooter 300 cc Kymco

RIFERIMENTO ORIGINALE

Kymco	00123195
-------	----------

APPLICABILITÀ

KYMCO X CITING I 300 4T 08-08, X CITING I R 300 4T 08-09

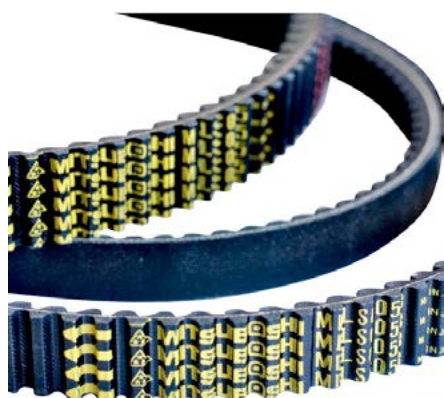

◀ cod. **9931550**  **BANDO**
Cinghia di trasmissione per motori scooter 125 cc Yamaha

RIFERIMENTO ORIGINALE

Yamaha	4CW176410200
--------	--------------

APPLICABILITÀ

MBK FLAME F 125 4T 00-00, FLAME R 125 4T 96-99, FLAME T 125 4T 95-99 **YAMAHA** CYGNUS R (XC K) 125 4T 97-98, CYGNUS R (XC) 125 4T 99-03, CYGNUS125 (XCT) 125 4T 95-98

◀ cod. **9931560**  **BANDO**

◀ cod. **9935750**  **MITSUBOSHI**
Cinghia di trasmissione per motori scooter 125 cc Yamaha

RIFERIMENTO ORIGINALE

Yamaha	5ML176410000
--------	--------------

APPLICABILITÀ

YAMAHA CYGNUS X (NXC) 125 4T 04-06, CYGNUS X IE EU3 (NXC) 125 4T 07-11

◀ cod. **9931610**

◀ cod. **9935760**  **MITSUBOSHI**
Cinghia di trasmissione per motori scooter 150 cc Yamaha

RIFERIMENTO ORIGINALE

Yamaha	52SE76410000
--------	--------------

APPLICABILITÀ

YAMAHA XC125R MAJESTY S 125 4T 14-14, XENTER 125 4T 12-17, XENTER 150 4T 12-16

◀ cod. **9931680**  **BANDO**
Cinghia di trasmissione per motori scooter 150 cc Sym

RIFERIMENTO ORIGINALE

Sym	1B01ARA01
-----	-----------

APPLICABILITÀ

SYM SYMPHONY 125 4T 09-09, SYMPHONY S 125 4T 09-10, SYMPHONY S 125 4T 12-14, SYMPHONY SR 125 4T 10-10, SYMPHONY SR 125 4T 12-12, SYMPHONY 150 4T 09-09, SYMPHONY S 150 4T 10-10, SYMPHONY S 150 4T 12-14, SYMPHONY SR 150 4T 10-10, SYMPHONY SR 150 4T 12-12

◀ cod. **9935220**  **MITSUBOSHI**
Cinghia di trasmissione per motori scooter 125/200 cc Aprilia

RIFERIMENTO ORIGINALE

Aprilia	856026
---------	--------

APPLICABILITÀ

APRILIA SCARABEO IE LIGHT 125 4T 09-12, SCARABEO LIGHT 125 4T 07-08, SCARABEO IE LIGHT 200 4T 11-12

◀ cod. **9935230**  **MITSUBOSHI**
Cinghia di trasmissione per motori scooter 600 cc BMW

RIFERIMENTO ORIGINALE

BMW	24827729767
-----	-------------

APPLICABILITÀ

BMW BMW C 600 SPORT [K18] 650 4T 11-15, BMW C 650 GT 2016 [K19] 650 4T 16-16, BMW C 650 GT [K19] 650 4T 11-15, BMW C 650 SPORT 2016 [K18] 650 4T 16-16

MAXI SCOOTER

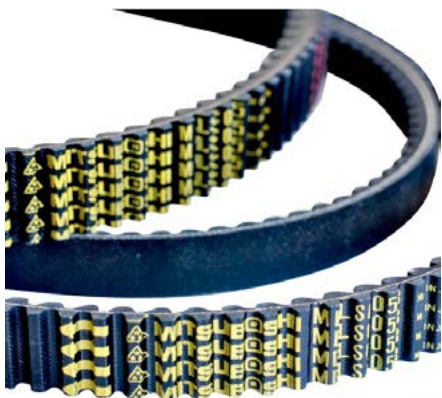

- ◀ cod. **9935250**  **MITSUBISHI**
Cinghia di trasmissione per motori scooter 600cc Honda

RIFERIMENTO ORIGINALE

Honda	23100MCT003
-------	-------------

APPLICABILITÀ

HONDA SILVER WING [FJS] 600 4T 01-10, SW-T [FJS] 600 4T 11-13

- ◀ cod. **9935260**  **MITSUBISHI**
Cinghia di trasmissione per motori scooter 125/150 cc Keeway

RIFERIMENTO ORIGINALE

Keeway	24160-J05-F000
--------	----------------

APPLICABILITÀ

KEEWAY ARN 125 4T 06-08, F-ACT 125 4T 07-08, FOCUS 125 4T 06-06, MATRIX 125 4T 06-08, ARN 150 4T 06-08, F-ACT 150 4T 07-08, FOCUS 150 4T 06-06, MATRIX 150 4T 06-08

- ◀ cod. **9935280**  **MITSUBISHI**
Cinghia di trasmissione per motori scooter 250 cc Kymco

RIFERIMENTO ORIGINALE

Kymco	23100-LLJ3-E00 (00127543)
-------	---------------------------

APPLICABILITÀ

KYMCO PEOPLE LC 250 4T 03-04, PEOPLE S 250 4T 06-06, PEOPLE S I 250 4T 07-07, X CITING 250 4T 05-05, PEOPLE S I 300 4T 08-08

- ◀ cod. **9935290**  **MITSUBISHI**
Cinghia di trasmissione per motori scooter 500cc Kymco

RIFERIMENTO ORIGINALE

Kymco	23100-LBA2-E001 (00127038)
-------	----------------------------

APPLICABILITÀ

KYMCO X CITING 500 4T 05-05, X CITING I 500 4T 06-08, X CITING I R 500 4T 07-08, X CITING R 500 4T 09-09

- ◀ cod. **9935300**  **MITSUBISHI**
Cinghia di trasmissione per motori scooter 250 cc Kymco

RIFERIMENTO ORIGINALE

Kymco	23100-LDF2-9000 (00127086)
-------	----------------------------

APPLICABILITÀ

KYMCO X CITING I 250 4T 06-07

- ◀ cod. **9935310**  **MITSUBISHI**
Cinghia di trasmissione per motori scooter 125 cc Kymco

RIFERIMENTO ORIGINALE

Kymco	23100-LFA7-E0A (00123267)
-------	---------------------------

APPLICABILITÀ

KYMCO DOWNTOWN E4 125 4T 16-16, DOWNTOWN I 125 4T 09-16, K-XCT I 125 4T 12-14, PEOPLE GTI 125 4T 10-10, PEOPLE GTI 125 4T 14-14, X-TOWN CBS 125 4T-4V 16-16

- ◀ cod. **9935320**  **MITSUBISHI**
Cinghia di trasmissione per motori scooter 300 cc Kymco

RIFERIMENTO ORIGINALE

Kymco	23100LEA7 E00 (00123257)
-------	--------------------------

APPLICABILITÀ

KYMCO DOWNTOWN ABS 300 4T 10-10, DOWNTOWN I 300 4T 09-09, DOWNTOWN I 300 4T 11-11, DOWNTOWN I ABS 300 4T 11-16, K-XCT I 300 4T 12-12, K-XCT I ABS 300 4T 14-14, PEOPLE GTI 300 4T 10-11, PEOPLE GTI 300 4T 14-14, PEOPLE GTI ABS 300 4T 12-12, PEOPLE GTI ABS 300 4T 14-14, PEOPLE GTI ABS E4 300 4T 16-16, DOWNTOWN ABS E4 350 4T 16-16, DOWNTOWN I ABS 350 4T 15-15

MAXI SCOOTER

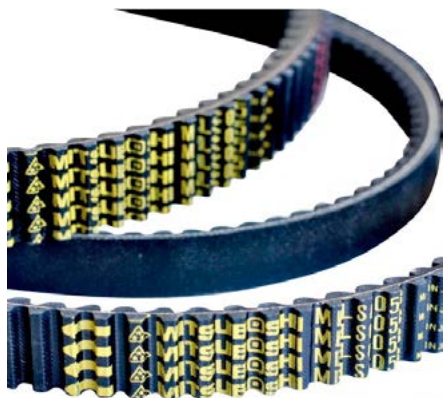

◀ **cod. 9935330**  **MITSUBOSHI**
Cinghia di trasmissione per motori scooter 200 cc Kymco

RIFERIMENTO ORIGINALE

Kymco	23100-LGF9-E0B (00123279)
-------	---------------------------

APPLICABILITÀ

KYMCO DOWNTOWN I 200 4T 10-10, PEOPLE GTI 200 4T 10-10,
PEOPLE GTI 200 4T 14-14

◀ **cod. 9935350**  **MITSUBOSHI**
CINGHIA DI TRASMISSIONE PER MOTORI SCOOTER 125 CC PEUGEOT

RIFERIMENTO ORIGINALE

Peugeot	771534
---------	--------

APPLICABILITÀ

PEUGEOT CITYSTAR 125 4T-2V 11-14, CITYSTAR LC 125 4T-4V 11-16, SATELIS 125 4T-4V 06-11, SATELIS 2 PREMIUM 125
4T-4V 12-14, SATELIS RS IE 125 4T-4V 06-11

◀ **cod. 9935360**  **MITSUBOSHI**
Cinghia di trasmissione per motori scooter 400 cc Peugeot

RIFERIMENTO ORIGINALE

Peugeot	781317
---------	--------

APPLICABILITÀ

Peugeot Metropolis 400

◀ **cod. 9935380**  **MITSUBOSHI**
Cinghia di trasmissione per motori scooter 125 cc Peugeot

RIFERIMENTO ORIGINALE

Peugeot	775218
---------	--------

APPLICABILITÀ

PEUGEOT GEOPOLIS 125 4T-4V 06-13

◀ **cod. 9935390**  **MITSUBOSHI**
Cinghia di trasmissione per motori scooter 125 cc Peugeot

RIFERIMENTO ORIGINALE

Peugeot	772816
---------	--------

APPLICABILITÀ

PEUGEOT SATELIS COMPRESSOR 125 4T-4V 06-06, CITYSTAR LC 200 4T-4V 12-15

◀ **cod. 9935400**  **MITSUBOSHI**
Cinghia di trasmissione per motori scooter 400 cc Peugeot

RIFERIMENTO ORIGINALE

Peugeot	786232
---------	--------

APPLICABILITÀ

PEUGEOT METROPOLIS 400 4T 13-16, SATELIS 400 4T 13-16

MAXI SCOOTER

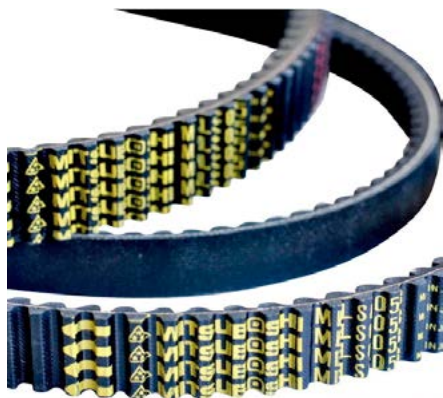

◀ cod. **9935430**  **MITSUBISHI**
Cinghia di trasmissione per motori scooter 125 cc Piaggio

RIFERIMENTO ORIGINALE

Piaggio	825059
---------	--------

APPLICABILITÀ

APRILIA MOJITO RETRO' CUSTOM 125 4T 99-01 **PIAGGIO** HEXAGON LX4 125 4T 98-99, LIBERTY 125 4T 98-00

◀ cod. **9935450**  **MITSUBISHI**
Cinghia di trasmissione per motori scooter 200 cc Piaggio

RIFERIMENTO ORIGINALE

Piaggio	842011
---------	--------

APPLICABILITÀ

APRILIA SCARABEO 200 4T 03-03, SCARABEO EU3 200 4T 06-06, SPORT CITY CUBE 200 4T 08-10, SPORT CITY EU3 200 4T 06-08 **PIAGGIO** BEVERLY 200 4T 01-03, CARNABY 200 4T 07-08

◀ cod. **9935460**  **MITSUBISHI**
Cinghia di trasmissione per motori scooter 500 cc Piaggio

RIFERIMENTO ORIGINALE

Piaggio	827826
---------	--------

APPLICABILITÀ

APRILIA ATLANTIC 500 4T 01-04 **PIAGGIO** X9 500 4T 01-02

◀ cod. **9935470**  **MITSUBISHI**
Cinghia di trasmissione per motori scooter 250 cc Piaggio

RIFERIMENTO ORIGINALE

Piaggio	82941R
---------	--------

APPLICABILITÀ

APRILIA ATLANTIC 250 4T 03-05, ATLANTIC EU3 250 4T 06-08, ATLANTIC 300 4T 10-11, SR MAX 300 4T 11-14
DERBI GP1 250 4T 06-07, GP1 LOW SEAT EU3 250 4T 07-08
GILERA NEXUS EU3 250 4T 06-07, OREGON 250 4T 06-10, NEXUS EU3 300 4T 08-11
MALAGUTI MADISON 3 250 4T 06-09, MADISON RS 250 4T 04-04, PHANTOM MAX 250 4T 04-04 **PIAGGIO** MP3 250 4T 06-08, MP3 LT 250 4T 08-09, MP3 MIC 250 4T 08-09, VESPA GT 60 EU3 250 4T 06-07, VESPA GTS 250 4T 05-16, VESPA GTS ABS 250 4T 05-12, VESPA GTV 250 4T 06-09, VESPA GTV 4T NAVY EU3 250 4T 07-07, X-EVO 250 4T 07-16, X7 EU3 250 4T 08-08, X8 EU3 250 4T 05-08, X9 EVOLUTION 250 4T 04-04, X9 EVOLUTION 250 4T 06-06, MP3 4T 4V IE ERL IBRIDO 300 4T-4V 10-13, MP3 4T 4V IE LT IBRIDO 300 4T 10-11, MP3 IE LT 300 4T 10-11, MP3 IE LT TOURING 300 4T 11-13, MP3 IE LT/SPORT 300 4T 11-14, MP3 IE MIC 300 4T 10-11, MP3 IE TOURING 300 4T 11-12, MP3 LT BUSINESS - SPORT ABS - ENJOY 300 4T 14-15, MP3 YOURBAN ERL 300 4T 11-15, MP3 YOURBAN LT ERL 300 4T 11-12, VESPA GTS IE & TOURING 300 4T 12-16, VESPA GTS IE TOURING 300 4T 11-12, VESPA GTS SUPER 300 4T 08-16, VESPA GTS SUPER SPORT 300 4T 10-13, VESPA GTV 4T 4V IE 300 4T 10-13, VESPA GTV VIA MONTENAPOLEONE 300 4T 10-10, X7 EVO IE EU3 300 4T 09-10

◀ cod. **9935490**  **MITSUBISHI**
Cinghia di trasmissione per motori scooter 350 cc Piaggio

RIFERIMENTO ORIGINALE

Piaggio	83025R
---------	--------

APPLICABILITÀ

PIAGGIO BEVERLY 4T 4V IE EU3 350 4T 11-14, BEVERLY 4T ST IE ABS 350 4T 16-16, X10 4T 4V IE EURO3 350 4T 12-15

◀ cod. **9935500**  **MITSUBISHI**
Cinghia di trasmissione per motori scooter 500 cc Piaggio

RIFERIMENTO ORIGINALE

Piaggio	849090
---------	--------

APPLICABILITÀ

APRILIA SCARABEO LIGHT 500 4T 06-08
GILERA FUOCO 4T-4V IE E3 LT 500 4T 13-14, FUOCO IE EU3 500 4T 07-13, NEXUS EU3 500 4T 06-08, NEXUS SP EU3 500 4T 06-07 **PIAGGIO** BEVERLY CRUISER 500 4T 07-12, MP3 LT BUSINESS ABS 500 4T 14-16, MP3 LT SPORT/BUSINESS 500 4T 11-13, MP3 RL SPORT-BUSINESS 500 4T 11-12, MP3 SPORT ABS 500 4T 14-16, X10 4T-4V IE EU3 500 4T 12-14

MAXI SCOOTER

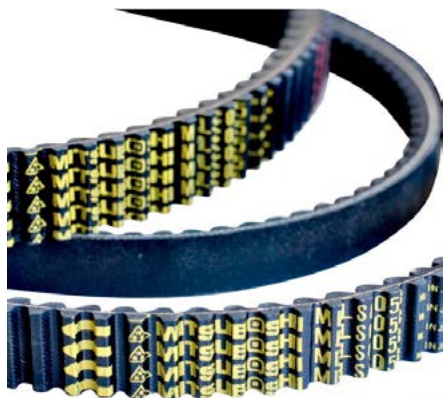

- ◀ cod. **9935510**  **MITSUBISHI**
Cinghia di trasmissione per motori scooter 250 cc Suzuki

RIFERIMENTO ORIGINALE

Suzuki	27601-14F01-000
--------	-----------------

APPLICABILITÀ

SUZUKI AN BURGMAN K1/K2 250 4T 01-02, AN BURGMAN W/X/Y 250 4T 98-00

- ◀ cod. **9935520**  **MITSUBISHI**
Cinghia di trasmissione per motori scooter 400 cc Suzuki

RIFERIMENTO ORIGINALE

Suzuki	27601-15F03-000
--------	-----------------

APPLICABILITÀ

SUZUKI AN BURGMAN X/K2 400 4T 99-02

- ◀ cod. **9935530**  **MITSUBISHI**
Cinghia di trasmissione per motori scooter 125 cc Suzuki

RIFERIMENTO ORIGINALE

Suzuki	27601-20H00-000
--------	-----------------

APPLICABILITÀ

SUZUKI UX SIXTEEN K8/LO 150 4T 08-10, UX SIXTEEN L1 150 4T 11-11

- ◀ cod. **9935540**  **MITSUBISHI**
Cinghia di trasmissione per motori scooter 150 cc Suzuki

RIFERIMENTO ORIGINALE

Suzuki	27601-20H60-000
--------	-----------------

APPLICABILITÀ

SUZUKI UX SIXTEEN K8/LO 150 4T 08-10, UX SIXTEEN L1 150 4T 11-11

- ◀ cod. **9935550**  **MITSUBISHI**
Cinghia di trasmissione per motori scooter 300 cc Sym

RIFERIMENTO ORIGINALE

Sym	1B01LEA01 (23100-LEA-000)
-----	---------------------------

APPLICABILITÀ

SYM CITYCOM 300 4T-4V 08-09, CITYCOM EFI 300 4T-4V 10-11, CITYCOM I CBS 300 4T-4V 12-12

- ◀ cod. **9935560**  **MITSUBISHI**
Cinghia di trasmissione per motori scooter 300 cc Sym

RIFERIMENTO ORIGINALE

Sym	1B01HWA01
-----	-----------

APPLICABILITÀ

SYM JOYMAX EVO 300 4T-4V 09-09, JOYMAX EVO I 300 4T-4V 10-10

- ◀ cod. **9935580**  **MITSUBISHI**
Cinghia di trasmissione per motori scooter 400 cc Yamaha

RIFERIMENTO ORIGINALE

Yamaha	5RU176411000
--------	--------------

APPLICABILITÀ

YAMAHA MAJESTY 400 4T 07-08, MAJESTY ABS 400 4T 07-08

MAXI SCOOTER

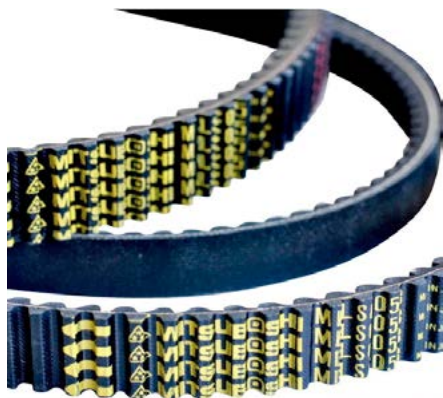

◀ cod. **9935610**  **MITSUBOSHI**
Cinghia di trasmissione per motori scooter 400 cc Yamaha

RIFERIMENTO ORIGINALE

Yamaha	34B176410000
--------	--------------

APPLICABILITÀ

YAMAHA MAJESTY 400 4T 09-11, MAJESTY ABS 400 4T 09-11

◀ cod. **9935620**  **MITSUBOSHI**
Cinghia di trasmissione per motori scooter 125 cc 4T Yamaha

RIFERIMENTO ORIGINALE

Yamaha	5NWE76410000
--------	--------------

APPLICABILITÀ

Yamaha Vity 125 cc 2008/2012

◀ cod. **9935630**  **MITSUBOSHI**
Cinghia di trasmissione per motori scooter 125 cc 4T Yamaha

RIFERIMENTO ORIGINALE

Yamaha	5S9E76410000
--------	--------------

APPLICABILITÀ

YAMAHA BW'S 4T 125 4T 10-10

◀ cod. **9935640**  **MITSUBOSHI**
Cinghia di trasmissione per motori scooter 125 cc 4T Yamaha

RIFERIMENTO ORIGINALE

Yamaha	5NWE76410000
--------	--------------

APPLICABILITÀ

Yamaha 125 Vity

◀ cod. **9935650**  **MITSUBOSHI**
Cinghia di trasmissione per motori scooter 400 cc Minarelli/Yamaha

RIFERIMENTO ORIGINALE

Yamaha	1SDE76410000
--------	--------------

APPLICABILITÀ

YAMAHA X-MAX 400 4T-4V 13-16, X-MAX ABS 400 4T-4V 14-17, X-MAX IRONMAX ABS 400 4T-4V 16-16, X-MAX MOMODESIGN 400 4T-4V 14-14, X-MAX MOMODESIGN ABS 400 4T-4V 14-14, X-MAX RA 400 4T-4V 18-18

◀ cod. **9935870**  **MITSUBOSHI**
Cinghia Honda SH 125 / 150 cc ABS DAL 2013

APPLICABILITÀ

HONDA SH I ABS 125 4T-2V 13-17, SH I ABS 150 4T-2V 13-17

◀ cod. **9935880**  **MITSUBOSHI**
Cinghia Kymco ATV 500 MXU

APPLICABILITÀ

KYMCO MXU 500 4T 05-06, MXU I RS 500 4T 10-10, UXV I 500 4T 08-08, UXV I 500 4T 10-10, MXU 700 I 700 4T 13-13

MAXI SCOOTER

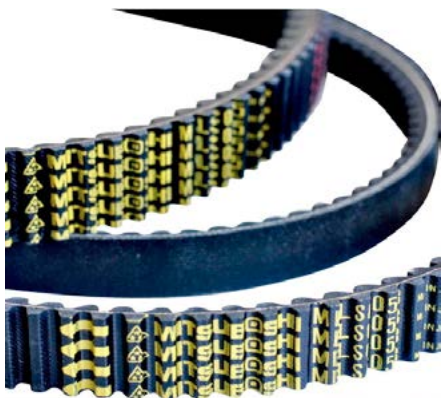

◀ cod. **9935890**  **MITSUBOSHI**

Cinghia Kymco My Road 700

APPLICABILITÀ

KYMCO MYROAD 1700 4T 11-16

◀ cod. **9935900**  **MITSUBOSHI**

Cinghia Kymco X-Citing 400 cc

APPLICABILITÀ

KYMCO X CITING I 400 4T 15-15, X CITING I ABS 400 4T 14-15, X CITING I ABS E4 400 4T 16-17, XCITING I 400 4T 13-13

◀ cod. **9935910**  **MITSUBOSHI**

Cinghia Kymco G- Dink 300 cc

APPLICABILITÀ

KYMCO G-DINK 300 4T-2V 12-12, G-DINK I ABS E4 300 4T-2V 17-17

◀ cod. **9935920**  **MITSUBOSHI**

Cinghia piaggio x9 200 - runner 200 cc

APPLICABILITÀ

APRILIA ATLANTIC 200 4T 03-05

DERBI BOULEVARD EU2 200 4T 05-06

GILERA DNA 180 4T 01-01, RUNNER VXR 180 4T 00-01, RUNNER VXR 200 4T 02-06, RUNNER VXR 4T ST EU3 200 4T 08-11, RUNNER VXR EU3 200 4T 07-07

PIAGGIO HEXAGON GTX 180 4T 00-00, SUPER HEXAGON GTX 12 180 4T 01-02, X9 AMALFI 180 4T 00-03, LIBERTY 200 4T 06-06, LIBERTY 4T EU3 200 4T 06-08, LIBERTY 4T SPORT EU3 200 4T 06-07, LIBERTY RST 200 4T 04-04, LIBERTY SPORT 200 4T 06-06, VESPA GRANTURISMO 200 4T 03-07, X8 200 4T 04-07, X9 200 4T 02-03, X9 EVOLUTION 200 4T 03-03

◀ cod. **9935930**  **MITSUBOSHI**

Cinghia Aprilia-Gilera 850 cc

APPLICABILITÀ

APRILIA MANA 850 4T-4V 07-11, MANA GT 850 4T-4V 09-16, SRV - SRV ABS ATC 850 4T-4V 12-14

GILERA GP 800 4T-4V 07-11, GP CENTENARIO 800 4T-4V 09-09

◀ cod. **9935940**  **MITSUBOSHI**

Cinghia Suzuki An125 cc

APPLICABILITÀ

Suzuki AN S-Y 125 4T 95-00

◀ cod. **9935960**  **MITSUBOSHI**

Cinghia Yamaha T- Max 530 cc

APPLICABILITÀ

YAMAHA T-MAX 59C 530 4T 12-16, T-MAX 59C ABS 530 4T 12-16, T-MAX 59C SP 530 4T 15-15, T-MAX 59C SP ABS 530 4T 15-16, XP530-A T-MAX SX 530 4T 17-19, XP530D-A T-MAX DX 530 4T 17-19, XP530E-A T-MAX 530 4T 17-18

◀ cod. **9935970**  **MITSUBOSHI**

Cinghia Honda PCX 125cc 10-14

APPLICABILITÀ

HONDA PCX 125 4T-2V 12-14

◀ cod. **9935980**  **MITSUBOSHI**

Cinghia Honda PCX 125cc 15-18

APPLICABILITÀ

HONDA PCX 125 4T-2V 15-18

NOVITÀ



- ◀ **cod. CT00725**
Collettore aspirazione motore scooter 50 cc Minarelli/Yamaha orizzontale

RIFERIMENTO ORIGINALE

Yamaha	4CUE35552000
Mbk	4CUE35552000

Malaguti	76004500
Aprilia	AP8206466



- ◀ **cod. CT00726**
Collettore aspirazione motore scooter 50 cc Minarelli/Yamaha verticale

RIFERIMENTO ORIGINALE

Yamaha	3VLE35552000
Mbk	3VLE35552000

Aprilia	AP8206514
---------	-----------



- ◀ **cod. CT00727**
Collettore aspirazione per motore scooter 50 cc Gilera/Piaggio

RIFERIMENTO ORIGINALE

Piaggio	830939
Gilera	830939

Derbi	830939
Aprilia	830939



- ◀ **cod. CT00728**
Collettore aspirazione per motore scooter Piaggio 125/150/180 cc

RIFERIMENTO ORIGINALE

Aprilia	AP8550171
---------	-----------

Piaggio	430206
---------	--------

APPLICABILITÀ

APRILIA SR 125 2T 99-01, SR 150 2T 99-01
GILERA RUNNER FX 125 2T 97-02, TYPHOON 125 2T 95-98, TYPHOON X-XR 125 2T 99-00, RUNNER FXR 180 2T 97-02

PIAGGIO HEXAGON 125 2T 94-97, SKYPPER 125 2T 94-97, HEXAGON 150 2T 94-97, SKYPPER 150 2T 94-97, HEXAGON LXT180 180 2T 98-99

NOVITÀ



- ◀ **cod. CT00729**
Collettore aspirazione per scooter YP 125cc '03

RIFERIMENTO ORIGINALE

Yamaha	5XME35850000
--------	--------------

MBK	5XME35850000
-----	--------------

APPLICABILITÀ

MBK SKYLINER E 125 4T 03-03, SKYLINER E 180 4T 03-03

YAMAHA MAJESTY E 125 4T 03-09, MAJESTY E 180 4T 03-06



◀ **cod. CT00730**
Collettore aspirazione per scooter YP 125 cc '02

RIFERIMENTO ORIGINALE

Yamaha	5DS135850000
MBK	5DS135850000

Malaguti	76005500
----------	----------

APPLICABILITÀ

BENELLI	VELVET 125 4T 99-01, VELVET 150 4T 99-01	MBK	DOODO 125 4T 00-00, FLAME T 125 4T 95-99, SKYLINER 125 4T 98-02, THUNDER 125 4T 01-02, DOODO 150 4T 01-02, SKYLINER 150 4T 00-02, THUNDER 150 4T 01-02
ITALJET	JUPITER 125 4T 01-02, MILLENIUM 125 4T 00-02, JUPITER 150 4T 01-02, MILLENIUM 150 4T 00-02	YAMAHA	MAJESTY 125 4T 98-00, MAJESTY (SNR1) 125 4T 01-01, MAJESTY (SNR8) 125 4T 02-02, MAXSTER 125 4T 01-02, TEO'S 125 4T 00-00, MAJESTY 150 4T 00-00, MAJESTY (SNS1) 150 4T 01-01, MAJESTY (SNS6) 150 4T 02-02, MAXSTER 150 4T 01-02, TEO'S 150 4T 01-02
MALAGUTI	MADISON 125 4T 99-01, MADISON R RESTYLING 125 4T 02-02, PHANTOM MAX 125 4T 03-03, MADISON T 150 4T 99-01		



◀ **cod. CT00731**
Collettore di aspirazione per Yamaha X-Max 250cc I

RIFERIMENTO ORIGINALE

Yamaha	1C0E35850000
--------	--------------

APPLICABILITÀ

YAMAHA	X-CITY 4T 07-13, X-MAX 4T 07-14, X-MAX ABS 4T 11-14, X-MAX BLACK 4T 09-11
---------------	---



◀ **cod. CT00734**
Collettore Aspirazione Piaggio Beverly 125cc '01-'03

RIFERIMENTO ORIGINALE

Aprilia	484748
Gilera	484748

Piaggio	484748
---------	--------

APPLICABILITÀ

APRILIA	ATLANTIC 125 4T 03-05, SCARABEO 125 4T 03-06, SPORT CITY 125 4T 04-06, ATLANTIC 200 4T 03-05	PIAGGIO	BEVERLY 125 4T 01-03, HEXAGON GTX 125 4T 00-00, SUPER HEXAGON GTX 125 4T 01-02, VESPA GRANTURISMO 125 4T 03-05, X9 125 4T 01-02, X9 EVOLUTION 125 4T 03-03, X9 AMALFI 180 4T 00-03, X9 200 4T 02-03, X9 EVOLUTION 200 4T 03-03
GILERA	DNA 125 4T 01-01, RUNNER VX 125 4T 00-04, DNA 180 4T 01-01, RUNNER VXR 180 4T 00-01, RUNNER VXR 200 4T 02-04		



◀ **cod. CT00735**
Collettore Aspirazione Piaggio Beverly 125/250cc '04-'07

RIFERIMENTO ORIGINALE

Aprilia	840949
Derbi	840949
Gilera	840949

Piaggio	840949
---------	--------

APPLICABILITÀ

APRILIA	ATLANTIC 250 4T 03-05, SCARABEO 250 4T 04-06	PIAGGIO	BEVERLY RST 125 4T 04-07, VESPA GRANTURISMO 125 4T 06-07, VESPA GRANTURISMO EU3 125 4T 06-07, VESPA GTV 125 4T 06-08, X8 125 4T 04-06, X8 PREMIUM EU2 125 4T 06-06, X9 EVOLUTION 125 4T 05-06, VESPA GRANTURISMO 200 4T 06-07, X8 200 4T 04-07, BEVERLY 250 4T 05-07, BEVERLY RST 250 4T 04-05, X9 EVOLUTION 250 4T 04-04, X9 EVOLUTION 250 4T 06-06
DERBI	GP1 EU 2 125 4T 06-06, GP1 250 4T 06-07		
GILERA	RUNNER 4T ST EU3 125 4T 08-16, RUNNER VX 125 4T 05-06, RUNNER VX RACE 125 4T 06-06, RUNNER VX SC 125 4T 06-07, RUNNER VXR RACE 200 125 4T 06-06, RUNNER VXR 200 4T 05-06, RUNNER VXR EU3 200 4T 07-07, OREGON 250 4T 06-10		



◀ **cod. CT00736**
Collettore Aspirazione Piaggio Liberty 125/150/200cc

RIFERIMENTO ORIGINALE

Aprilia	849465
Derbi	849465

Piaggio	849465
---------	--------

APPLICABILITÀ

APRILIA	MOJITO 125 4T 03-08, SPORT CITY ONE 4T EU3 125 4T 08-11, SR MOTARD 125 4T-2V 12-14	PIAGGIO	FLY 125 4T 05-07, FLY EU3 125 4T 07-11, LIBERTY 4T 125 4T 06-07, LIBERTY 4T 2V EURO3 125 4T 09-12, LIBERTY 4T EU3 DELIVERY - TNT 125 4T 08-15, LIBERTY RST 125 4T 04-05, LIBERTY SPORT 125 4T 06-06, TYPHOON 4T 2V E3 125 4T 10-11, VESPA LX 125 4T 05-06, VESPA LX EU3 125 4T 06-08, VESPA LXV 4T EU3 125 4T 06-09, X8 STREET EU2 125 4T 06-07, FLY 150 4T 05-07, FLY EU3 150 4T 08-11, LIBERTY MOC 4T 150 4T 09-13, VESPA LX 150 4T 05-06, VESPA LX EU3 150 4T 06-08, X8 STREET EU2 150 4T 06-08, LIBERTY 200 4T 06-06, LIBERTY RST 200 4T 04-04, LIBERTY SPORT 200 4T 06-06
DERBI	BOULEVARD 125 4T 03-04, BOULEVARD 4T EU3 125 4T 08-12, BOULEVARD EU2 125 4T 04-07, SONAR 4T 125 4T 09-11, VARIANT SPORT 4T EU3 125 4T 12-12, BOULEVARD 150 4T 03-04, BOULEVARD 4T E3 150 4T 10-10, BOULEVARD EU3 150 4T 04-07, SONAR 4T 150 4T 09-09, BOULEVARD EU2 200 4T 05-06		



◀ cod. **CT00737**
Collettore Aspirazione Aprilia Scarabeo 50cc 4T '09

RIFERIMENTO ORIGINALE

Aprilia	845946
Derbi	845946

Piaggio	845946
---------	--------

APPLICABILITÀ

APRILIA	SCARABEO 4T RESTYLING EU3 50 4T 06-09, SPORT CITY ONE 4T 50 4T 08-10	PIAGGIO	FLY 4T 50 4T 05-07, FLY 4T & 25-30 KM/H 50 4T 08-11, FLY 4T MOTORE CHN 50 4T 06-07, LIBERTY 4T 50 4T 05-08, LIBERTY 4T DELIVERY - SINGLE 50 4T 10-14, LIBERTY 4T DELIVERY TNT 50 4T 09-09, LIBERTY 4T PTT - DOUBLE - NEXIVE 50 4T 09-17, LIBERTY 4T SPORT 50 4T 06-08, LIBERTY MOC 4T & ELLE 50 4T 09-16, VESPA LX 4T 50 4T 05-09, ZIP 4T 50 4T 06-13
DERBI	ATLANTIS 4T EU2 50 4T 07-07, BOULEVARD 4T EU2 25KM/H 50 4T 09-09		



◀ cod. **CT00738**
Collettore Aspirazione Aprilia Scarabeo 50cc 4T '06

RIFERIMENTO ORIGINALE

Aprilia	969405
Derbi	969405

Piaggio	969405
---------	--------

APPLICABILITÀ

APRILIA	SCARABEO 4T 50 4T 02-06	PIAGGIO	LIBERTY 4T 50 4T 00-02, LIBERTY 4T RST 50 4T 04-04, VESPA ET4 50 4T 00-05, ZIP 4T 50 4T 00-05
DERBI	ATLANTIS 4T 50 4T 04-06		



◀ cod. **CT00739**
Collettore Aspirazione Piaggio Liberty 125cc '98-'00

RIFERIMENTO ORIGINALE

Piaggio	480799
---------	--------

APPLICABILITÀ

PIAGGIO	LIBERTY 125 4T 98-00, SFERA 125 4T 95-97, VESPA ET4 125 4T 96-98
----------------	--



◀ cod. **CT00740**
Collettore Aspirazione Piaggio Liberty 125cc '00-'02

RIFERIMENTO ORIGINALE

Derbi	485587
Piaggio	485587

APPLICABILITÀ

DERBI	BOULEVARD 125 4T 02-02, BOULEVARD 150 4T 02-02	PIAGGIO	LIBERTY 125 4T 01-02, SKYPPER 4T 125 4T 00-02, VESPA ET4 125 4T 99-02, ZIP 125 4T 00-02, SKYPPER 4T 150 4T 00-02, VESPA ET4 150 4T 99-02
--------------	--	----------------	--



◀ cod. **CT00741**
Collettore Aspirazione Peugeot Ludix 50cc

RIFERIMENTO ORIGINALE

Peugeot	768537
---------	--------

APPLICABILITÀ

PEUGEOT	JET C-TECH 50 2T 90-02, JET FORCE 50 2T 90-02, LUDIX 50 2T 90-02, LUDIX BLASTER 50 2T 90-02
----------------	---



◀ **cod. CT00742**
Collettore Aspirazione Kymco Agility 125/150cc R16

RIFERIMENTO ORIGINALE

Kymco	117091	Kymco	1711A-LEJ3-E10
-------	--------	-------	----------------

APPLICABILITÀ

KYMCO AGILITY R16 125 4T 08-09, SUPER 8 125 4T 08-09, AGILITY R16 150 4T 08-09



◀ **cod. CT00743**
Collettore Aspirazione Kymco Agility 50cc 4T

RIFERIMENTO ORIGINALE

Kymco	117075	Kymco	1711A-LEJ3-E10
-------	--------	-------	----------------

APPLICABILITÀ

KYMCO AGILITY 4T R12 50 4T 07-08, AGILITY R12 50 4T 05-05, AGILITY R16 50 4T 08-09, AGILITY R16 50 4T 12-12, AGILITY RS 50 4T 09-09, FILLY 50 4T 98-00, FILLY LX 50 4T 01-02, LIKE 50 4T 09-09, PEOPLE S 4T 50 4T 06-08, SUPER 8 4T 50 4T 07-07, SUPER 8 4T 50 4T 09-09, VITALITY 4T 50 4T 04-04



◀ **cod. CT00744**
Collettore aspiraz. sx Yamaha T-Max ie 500cc '04-'11

APPLICABILITÀ

YAMAHA T-MAX 4B5 500 4T 09-11, T-MAX 4B5 ABS 500 4T 08-11, T-MAX 5VU 500 4T 04-08, T-MAX 5VU ABS 500 4T 05-07, T-MAX 5VU BLACK MAX 500 4T 06-06, T-MAX 5VU BLACK MAX - NIGHT MAX 500 4T 07-07



◀ **cod. CT00745**
Collettore aspiraz. dx Yamaha T-Max ie 500cc '04-'11

APPLICABILITÀ

YAMAHA T-MAX 4B5 500 4T 09-11, T-MAX 4B5 ABS 500 4T 08-11, T-MAX 5VU 500 4T 04-08, T-MAX 5VU ABS 500 4T 05-07, T-MAX 5VU BLACK MAX 500 4T 06-06, T-MAX 5VU BLACK MAX - NIGHT MAX 500 4T 07-07



◀ **cod. CT00746**
Collettore aspiraz. AM6

APPLICABILITÀ

APRILIA	CLASSIC 50 2T 92-99, MX 50 2T 04-04, MX MOTARD 50 2T 95-03, RS 50 2T 96-05, RX 50 2T 03-04, RX ENDURO 50 2T 95-03, RX RACING 50 2T 03-06, TUONO 50 2T 03-04	PEUGEOT	SUPERMOTARD 50 2T 90-02, XP6 TRAIL S/AVV. ELETTRICO 50 2T 90-02, XR6 RACING CAT. C/AVV.ELETT. 50 2T 90-02
BETA	RR 2T 50 EU4 50 2T 18-20, RR 50 RACING EU4 50 2T 18-20	RIEJU	MRT 50 2T 09-12, MRT 50 EU4 50 2T 18-20, MRT PRO 50 2T 09-12, MRT PRO EU4 50 2T 18-20, MRT PRO REPLICA EU4 50 2T 18-20, MRT PRO REPLICA SM EU4 50 2T 18-20, MRT PRO SM 50 2T 09-12, MRT PRO SM EU4 50 2T 18-20, MRT SM 50 2T 09-12, MRT SM EU4 50 2T 18-20, MRT TROPHY EU4 50 2T 18-20, MRX 50 2T 01-04, MRX PRO 50 2T 01-04, RR 50 2T 05-06, RS1 50 2T 98-01, RS2 MATRIX 50 2T 05-06, RS2 MATRIX PRO 50 2T 05-06, RS2 NAKED 50 2T 04-05, RS3 EU4 50 2T 18-20, RS3 NDK EU4 50 2T 18-20, SMX E.S./K.S. 50 2T 01-01, SMX PRO E.S./K.S. 50 2T 03-03, SPIKE 50 2T 98-01
CH	SM 50 2T 00-10, WR 50 2T 00-10, WSM 50 2T 00-10	SHERCO	FACTORY SE-R EU4 50 2T 18-20, FACTORY SE-RS EU4 50 2T 18-20, FACTORY SILVER SM-R EU4 50 2T 18-20, FACTORY SILVER SM-RS EU4 50 2T 18-20, FACTORY SM-R EU4 50 2T 18-20, FACTORY SM-RS EU4 50 2T 18-20, HRD ENDURO 50 2T 09-13, HRD MOTARD 50 2T 09-13
HUSQUARNA	ENDURO 50 2T 11-11, MOTARD 50 2T 11-11	VENT	BAJA 50 2T 18-20, BAJA RR 50 2T 18-20, DERAPAGE 50 2T 18-20, DERAPAGE RR 50 2T 18-20
CMC	ENDURO 50 2T 11-11, MOTARD 50 2T 11-11	YAMAHA	DT R 50 2T 03-11, DT RSM 50 2T 03-05, DT X 50 2T 06-11, TZR 50 2T 03-08, TZR 50 2T 10-11, TZR RR 50 2T 05-05
FANTIC	CABALLERO MOTARD 50 2T 06-10, CABALLERO REGOLARITÀ 50 2T 06-10, ENDURO COMPETITION EU4 50 2T 18-20, ENDURO PERFORMANCE EU4 50 2T 18-20, MOTARD COMPETITION EU4 50 2T 18-20, MOTARD PERFORMANCE EU4 50 2T 18-20		
HM	BAJA, DERAPAGE BASIC 50 2T 10-11, CMC 50 2T 10-11, CRE BAJA RR, DERAPAGE RR 50 2T 07-11, CRE BAJA, DERAPAGE 50 2T 07-11, CRE SIX COMPETITION 50 2T 10-11, CRE SIX, BAJA, DERAPAGE 50 2T 95-06, CRE SIX, DERAPAGE COMPETITION 50 2T 07-09, DERAPAGE COMPETITION 50 2T 10-11		
MALAGUTI	CNK DRAGON 50 2T 05-07, XSM 50 2T 03-03, XTM 50 2T 03-03		
MBK	X LIMIT 50 2T 03-04, X POWER 50 2T 03-04		
MOTORHISPANIA	FURIA 50 2T 97-00, FURIA MAX 50 2T 10-12, RX 50 2T 09-12, RX R 50 2T 09-12		



- ◀ cod. **CO00001**
Convogliatore per motori scooter 50 cc Minarelli/Yamaha tipo verticale
- ◀ cod. **CO00002**
Convogliatore per motori scooter 50 cc Minarelli/Yamaha tipo orizzontale corto e lungo
- ◀ cod. **CO00003**
Cuffia convogliatore per motori scooter 50 cc Minarelli/Yamaha tipo orizzontale
- ◀ cod. **CO00004**
Cuffia convogliatore per motori scooter 50 cc Minarelli/Yamaha tipo verticale

SERIE CUSCINETTI CAMBIO



- ◀ cod. **NTS0100**
Serie cuscinetti cambio AM 3/4/5

APPLICABILITÀ

APRILIA EUROPA 50 2T 91-92, PEGASO 50 2T 92-94, RS 50 2T 91-95, RX 3-5 MARCE 50 2T 91-94

MALAGUTI FIFTY EVOLUTION 50 2T 90-93
MINARELLI MOTORE AM 3-4-5 50 2T 91-95

NOVITÀ



- ◀ cod. **NTS0101**
Serie cuscinetti cambio AM6 Prima serie

APPLICABILITÀ

APRILIA CLASSIC 50 2T 92-99, MX 50 2T 04-04, MX MOTARD 50 2T 95-03, RS 50 2T 96-05, RX 50 2T 03-04, RX ENDURO 50 2T 95-03, RX RACING 50 2T 03-06, TUONO 50 2T 03-04

BETA RR ALU 50 2T 08-12

CH SQUARNA HU-SM 50 2T 00-10, WR 50 2T 00-10, WSM 50 2T 00-10

CMC ENDURO 50 2T 11-11, MOTARD 50 2T 11-11

FANTIC CABALLERO MOTARD 50 2T 06-10, CABALLERO MOTARD COMPETITION 50 2T 06-10, CABALLERO REGOLARITÀ 50 2T 06-10, CABALLERO REGOLARITÀ COMPETITION 50 2T 06-10

HM BAJA, DERAPAGE BASIC 50 2T 10-11, CMC 50 2T 10-11, CRE BAJA RR, DERAPAGE RR 50 2T 07-11, CRE BAJA, DERAPAGE 50 2T 07-11, CRE SIX COMPETITION 50 2T 10-11, CRE SIX, BAJA, DERAPAGE 50 2T 95-06, CRE SIX, DERAPAGE COMPETITION 50 2T 07-09, DERAPAGE COMPETITION 50 2T 10-11

MALAGUTI CNK DRAGON 50 2T 05-07, XSM 50 2T 03-06, XSM POWER-UP 50 2T 07-10, XTM 50 2T 03-03, XTM 50 2T 06-06, XTM POWER-UP 50 2T 07-10

MBK X LIMIT 50 2T 03-04, X POWER 50 2T 03-04

MINARELLI MOTORE AM 6 1° SERIE 50 2T 96-11

MOTORH I SPANIA FURIA 50 2T 97-00, FURIA MAX 50 2T 10-12, RX 50 2T 09-12, RX R 50 2T 09-12

PEUGEOT SUPERMOTARD 50 2T 90-02, XP6 TRAIL S/AVV. ELETTRICO 50 2T 90-02, XR6 RACING CAT. C/AVV.ELETT. 50 2T 90-02

RIEJU MRT 50 2T 09-12, MRT PRO 50 2T 09-12, MRT PRO SM 50 2T 09-12, MRT SM 50 2T 09-12, MRX 50 2T 01-04, MRX PRO 50 2T 01-04, RR 50 2T 05-06, RS1 50 2T 98-01, RS2 MATRIX 50 2T 05-06, RS2 MATRIX PRO 50 2T 05-06, RS2 NAKED 50 2T 04-05, SMX E.S./K.S. 50 2T 01-01, SMX PRO E.S./K.S. 50 2T 03-03, SPIKE 50 2T 98-01

YAMAHA DT R 50 2T 03-11, DT RSM 50 2T 03-05, DT X 50 2T 06-11, TZR 50 2T 03-08, TZR 50 2T 10-11, TZR RR 50 2T 05-05

NOVITÀ



- ◀ cod. **NTS0102**
Serie cuscinetti cambio AM6 Seconda serie

APPLICABILITÀ

BETA RR 2T 50 EU4 50 2T 18-20, RR 50 RACING EU4 50 2T 18-20

FANTIC ENDURO COMPETITION EU4 50 2T 18-20, ENDURO PERFORMANCE EU4 50 2T 18-20, MOTARD COMPETITION EU4 50 2T 18-20, MOTARD PERFORMANCE EU4 50 2T 18-20

MINARELLI MOTORE AM 6 2° SERIE 50 2T 12-18

RIEJU MRT 50 EU4 50 2T 18-20, MRT PRO EU4 50 2T 18-20, MRT PRO REPLICA EU4 50 2T 18-20, MRT PRO REPLICA SM EU4 50 2T 18-20, MRT PRO SM EU4 50 2T 18-20, MRT SM EU4 50 2T 18-20, MRT TROPHY EU4 50 2T 18-20, RS3 EU4 50 2T 18-20, RS3 NDK EU4 50 2T 18-20

SHERCO FACTORY SE-R EU4 50 2T 18-20, FACTORY SE-RS EU4 50 2T 18-20, FACTORY SILVER SM-R EU4 50 2T 18-20, FACTORY SILVER SM-RS EU4 50 2T 18-20, FACTORY SM-R EU4 50 2T 18-20, FACTORY SM-RS EU4 50 2T 18-20

NOVITÀ

KIT CUSCINETTI E PARAOLI DI BANCO



◀ cod. **KK01000**
Kit cuscinetti (Kojo) paraoli di banco scooter Minarelli/Yamaha 50 cc

◀ cod. **KK01001**
Kit cuscinetti paraoli di banco AM 345/6

◀ cod. **KK01002**
Kit cuscinetti SKF e paraoli di banco scooter Minarelli/Yamaha 50 cc

◀ cod. **KK01003**
Kit cuscinetti paraoli di banco scooter Piaggio 50 cc

◀ cod. **KK01005**
Kit cuscinetti paraoli di banco Peugeot Speedfight 50 cc

◀ cod. **KK01008**
Kit cuscinetti paraoli di banco Derbi plurimarca 50 cc

◀ cod. **KK01009**
Kit cuscinetti SKF (speciali) e paraoli di banco scooter Piaggio 50 cc



◀ cod. **KK01011**
Kit cuscinetti SKF e paraoli di banco Vespa 50/90 cc
1 paraolio BASF 22,7x47,05x7,5 - 1 paraolio BAB 19x32x7 - 1 cuscinetto 20x47x14 (6204) - 1 cuscinetto 17x47x14 (6303)

◀ cod. **KK01012**
Kit cuscinetti SKF e paraoli di banco Vespa PK XL 50 cc Ape 50 cc
1 paraolio BA 20x32x70 - 1 paraolio BASF 22,7x47,05x7,5 - 1 cuscinetto 20x47x14 (6204) - 1 cuscinetto 17x47x14 (6303)



◀ cod. **KK01013**
Kit cuscinetti paraoli di banco Kymco 50 cc 2T

KIT CUSCINETTI E PARAOLI DI BANCO



◀ **cod. KK01006**
Kit cuscinetti paraoli di banco Suzuki Burgman 250/400 cc

APPLICABILITÀ

SUZUKI EPICURO 125 4T 99-01, UH BURGMAN K2/K6 125 4T 02-06, UH BURGMAN K7/LO 125 4T 07-10, UX SIXTEEN K8/LO 125 4T 08-10, EPICURO 150 4T 99-01, UH BURGMAN K2/K6 150 4T 02-06, UX SIXTEEN K8/LO 150 4T 08-10, UH BURGMAN K7/LO 200 4T 07-10, AN BURGMAN K3/K6 250 4T 03-06, AN BURGMAN K3/K6 400 4T 03-06, AN BURGMAN K7/LO 400 4T 07-10, AN BURGMAN X/K2 400 4T 99-02

◀ **cod. KK01007**
Kit cuscinetti paraoli di banco Yamaha Majesty 250/300 cc

APPLICABILITÀ

APRILIA	LEONARDO 250 4T 99-04, LEONARDO ST 250 4T 01-01, LEONARDO 300 4T 02-04	MBK	SKYLINER 250 4T 00-03, SKYLINER ABS 250 4T 03-03, KILIBRE 300 4T 03-06
BENELLI	VELVET 250 4T 99-03	YAMAHA	MAJESTY 250 4T 96-03, MAJESTY ABS 250 4T 03-03, MAJESTY DX 250 4T 98-99, X-CITY 250 4T 07-15, X-MAX 250 4T 05-16, X-MAX ABS 250 4T 14-15, VERSITY 300 4T 03-06
ITALJET	JUPITER 250 4T 00-02		
MALAGUTI	MADISON S 250 4T 99-01, PASSWORD 250 4T 05-06, PASSWORD EU3 250 4T 07-08		



◀ **cod. KK01010**
Kit cuscinetti paraoli di banco Minarelli/Yamaha 125/150/180 cc

APPLICABILITÀ

BENELLI	VELVET 125 4T 99-01, VELVET 150 4T 99-01	MBK	DOODO 125 4T 00-00, SKYLINER 125 4T 98-02, SKYLINER E 125 4T 03-03, THUNDER 125 4T 01-02, DOODO 150 4T 01-02, SKYLINER 150 4T 00-02, THUNDER 150 4T 01-02, SKYLINER E 180 4T 03-03
ITALJET	JUPITER 125 4T 01-02, MILLENNIUM 125 4T 00-02, JUPITER 150 4T 01-02, MILLENNIUM 150 4T 00-02	YAMAHA	MAJESTY 125 4T 98-00, MAJESTY (5NR1) 125 4T 01-01, MAJESTY (5NR8) 125 4T 02-02, MAJESTY E 125 4T 03-09, MAXSTER 125 4T 01-02, TEO'S 125 4T 00-00, MAJESTY 150 4T 00-00, MAJESTY (5NS1) 150 4T 01-01, MAJESTY (5NS6) 150 4T 02-02, MAXSTER 150 4T 01-02, TEO'S 150 4T 01-02, MAJESTY E 180 4T 03-06
MALAGUTI	MADISON 125 4T 99-01, MADISON R RESTYLING 125 4T 02-02, MADISON R RESTYLING EU2 125 4T 03-04, PHANTOM MAX 125 4T 03-03, MADISON T 150 4T 99-01		



◀ **cod. KK01014**
Kit cuscinetti paraoli di banco Honda SH 125/150 cc 4T fino al '12

APPLICABILITÀ

HONDA @ [NES] 125 4T 00-06, BALI 125 4T 96-01, DYLAN [SES] 125 4T 02-04, PANTHEON IE [FES] 125 4T-2V 03-05, PS1 [PES] 125 4T 06-10, SH 125 4T-2V 01-04, SH IE SCOOPY 125 4T-2V 05-12, SILVER WING [FES] 125 4T-2V 07-12, @ [NES] 150 4T 00-06, BALI 150 4T 96-01, DYLAN [SES] 150 4T 02-04, PANTHEON IE [FES] 150 4T-2V 03-05, PS1 [PES] 150 4T 06-10, SH 150 4T-2V 01-04, SH IE SCOOPY 150 4T 05-12, SILVER WING [FES] 150 4T-2V 07-12

NOVITÀ



◀ **cod. KK01015**
Kit cuscinetti SKF/paraoli banco Vespa 125 Primavera ET3

APPLICABILITÀ

PIAGGIO VESPA ET3 125 2T 76-83, VESPA PRIMAVERA 125 2T 67-83

NOVITÀ



◀ cod. **KF00050**
Alberi cambio **Vespa**
sigla: 6200
misure: 10x30x9

◀ cod. **KF00100**
Mozzi ciclomotore
sigla: 6201
misure: 12x32x10

◀ cod. **KF00150**
Tamburo **PX**
sigla: 6201/ZZ
misure: 12x32x10

◀ cod. **KF00200**
sigla: 6004
misure: 20x42x12

◀ cod. **KF00250**
Piaggio 102258
sigla: 6202
misure: 15x35x11

◀ cod. **KF00350**
Schermato
sigla: 6202/ZZ
misure: 15x35x11

◀ cod. **KF00450**
Piaggio banco frizione -
banco **Minarelli P4 - RV - GL - DL**
sigla: 6203
misure: 17x40x12

◀ cod. **KF00550**
Piaggio banco volano
sigla: 6204
misure: 20x47x14

◀ cod. **KF00600**
sigla: 6204/C3
misure: 20x47x14

◀ cod. **KF01000**
Lato trazione **Vespa** 50/90/125 cc
sigla: 6303
misure: 17x47x14

◀ cod. **KF01050**
sigla: 6303/C3
misure: 17x47x14

◀ cod. **KF01150**
Lato trazione **Lambretta**
sigla: 6305
misure: 25x62x17

◀ cod. **KF01450**
Campana frizione **Vespa** 50 cc/ET3
sigla: 16005
misure: 25x47x8

◀ cod. **KF01460**
Pompa acqua scooter
Minarelli/Yamaha 50 cc
sigla: 608-2RS1-C3
misure: 8x22x7

◀ cod. **KF01500**
Suzuki Burgman 250/400 cc
sigla: 6207
misure: 35x72x17

◀ cod. **KF05000**
Banco tutti i modelli scooter
Minarelli/Yamaha 50 cc
sigla: 6204TN9/C3
misure: 20x47x14

◀ cod. **KF05010**
Banco **P4 - RV - GL - DL**
sigla: 6203TN9/C3
misure: 17x40x12

◀ cod. **KF05020**
Albero frizione scooter **F10**
sigla: 6003TN9/C3
misure: 17x35x10

◀ cod. **KF05030**
Lato trazione **Vespa** 50/90/125 cc
sigla: 6303TN9/C3
misure: 17x47x14

◀ cod. **KF05040**
sigla: 6202TN9/C3
misure: 15x35x11



◀ cod. **KF05050**
Albero motore **Sfera**
sigla: BB1B447205A
misure: 20x52x12

◀ cod. **KF05060**
sigla: 6204TN9/C4
misure: 20x47x14

◀ cod. **KF05070**
Albero motore **Piaggio**
sigla: BB1-3055 B

◀ cod. **KF05080**
sigla: 6202 2RSH
misure: 15x35x11

◀ cod. **KF05090**
sigla: 61901 2RS1
misure: 12x24x6

◀ cod. **KF05100**
sigla: 6203/C3
misure: 17x40x12

◀ cod. **KF05110**
sigla: 6200/C3
misure: 10x30x9

◀ cod. **KF05120**
sigla: 6000-2RSH
misure: 10x26x8

◀ cod. **KF05130**
sigla: 6200-2RSH
misure: 10x30x9

◀ cod. **KF05140**
sigla: 6300-2RSH
misure: 10x35x11

◀ cod. **KF05150**
sigla: 6001-2RSH
misure: 12x28x8

◀ cod. **KF05160**
sigla: 6201/C3
misure: 12x32x10

◀ cod. **KF05170**
sigla: 6201-2RSH
misure: 12x32x10

◀ cod. **KF05180**
sigla: 6201-2RSH/C3
misure: 12x32x10

◀ cod. **KF05190**
sigla: 6301-2RSH
misure: 12x37x12

◀ cod. **KF05200**
sigla: 61902-2RS1
misure: 15x28x7

◀ cod. **KF05210**
sigla: 6002-2RSH
misure: 15x32x9

◀ cod. **KF05220**
sigla: 6202/C3
misure: 15x35x11

◀ cod. **KF05230**
sigla: 6202/C4
misure: 15x35x11

◀ cod. **KF05240**
sigla: 6202-RSH
misure: 15x35x11



◀ cod. **KF05250**
sigla: 6202-2RSH/C3
misure: 15x35x11

◀ cod. **KF05350**
sigla: 6303-2RSH
misure: 17x47x14

◀ cod. **KF05260**
sigla: 6302
misure: 15x42x13

◀ cod. **KF05360**
sigla: 6303-2RSH/C3
misure: 17x47x14

◀ cod. **KF05270**
sigla: 6302/C3
misure: 15x42x13

◀ cod. **KF05370**
sigla: 61904-2RS1
misure: 20x37x9

◀ cod. **KF05280**
sigla: 6302-2RSH
misure: 15x42x13

◀ cod. **KF05380**
sigla: 6004/C3
misure: 20x42x12

◀ cod. **KF05290**
sigla: 6302-2RSH/C3
misure: 15x42x13

◀ cod. **KF05390**
sigla: 6004-2RSH
misure: 20x42x12

◀ cod. **KF05300**
sigla: 6003-2RSH
misure: 17x35x10

◀ cod. **KF05400**
sigla: 6204/C5
misure: 20x47x14

◀ cod. **KF05310**
sigla: 6003-2RSH/C3
misure: 17x35x10

◀ cod. **KF05410**
sigla: 6204-2RSH
misure: 20x47x14

◀ cod. **KF05320**
sigla: 6203-2RSH
misure: 17x40x12

◀ cod. **KF05420**
sigla: 6204-2RSH/C3
misure: 20x47x14

◀ cod. **KF05330**
sigla: 6203-2RSH/C3
misure: 17x40x12

◀ cod. **KF05430**
sigla: 6204 TN9/C4H LHT23
misure: 20x47x14

◀ cod. **KF05340**
sigla: 6303/C4
misure: 17x47x14

◀ cod. **KF05440**
sigla: 6304/C3
misure: 20x52x15



◀ cod. **KF05450**
sigla: 6304-2RSH
misure: 20x52x15

◀ cod. **KF05460**
sigla: 6304 TN9/C4
misure: 20x52x15

◀ cod. **KF05470**
sigla: 61905-2RS1
misure: 25x42x9

◀ cod. **KF05480**
sigla: 6005-2RSH
misure: 25x47x12

◀ cod. **KF05490**
sigla: 6005-2RSH/C3
misure: 25x47x12

◀ cod. **KF05500**
sigla: BB1-3056 C
misure: 25x52x13

◀ cod. **KF05510**
sigla: 6205/C3
misure: 25x52x15

◀ cod. **KF05520**
sigla: 6205-2RSH
misure: 25x52x15

◀ cod. **KF05530**
sigla: 6205-2RSH/C3
misure: 25x52x15

◀ cod. **KF05540**
sigla: 6205 ETN9/C4
misure: 25x52x15

◀ cod. **KF05550**
sigla: BB1-0855
misure: 25x62x12

◀ cod. **KF05560**
sigla: 6305/C3
misure: 25x62x17

◀ cod. **KF05570**
sigla: 6305/C5
misure: 25x62x17

◀ cod. **KF05580**
sigla: 6305 TN9/C4
misure: 25x62x17

◀ cod. **KF05590**
sigla: 6206/C4
misure: 30x62x16

◀ cod. **KF05600**
sigla: 6206 TN9/C3
misure: 30x62x16

◀ cod. **KF05610**
sigla: 6206 TN9/C4H
misure: 30x62x16

◀ cod. **KF05620**
sigla: 608-2RSH/C3 LHT23
misure: 8x22x7

◀ cod. **KF05630**
sigla: 6207/C3
misure: 32x72x17

◀ cod. **KF05640**
sigla: NU204ECP
misure: 20x47x14

NOVITÀ



◀ **cod. NT06001**
 sigla: 6304C3
 misure: 20x52x15
APPLICABILITÀ: Carter Motore
RIFERIMENTO ORIGINALE

Yamaha	933063042100
MBK	933063042100

◀ **cod. NT06008**
 sigla: 608LLUC3/5K
 misure: 8x22x7
APPLICABILITÀ: Pompa Acqua
RIFERIMENTO ORIGINALE

Beta	1293388000
------	------------

◀ **cod. NT06002**
 sigla: SC04A31CS34Px1/2ASQF
 misure: 20x47x12
APPLICABILITÀ: Albero Motore
RIFERIMENTO ORIGINALE

Honda	91001-GM4-0331
-------	----------------

◀ **cod. NT06009**
 sigla: SF05A26Px1
 misure: 26x47x15
APPLICABILITÀ: Cuscinetto Sterzo
RIFERIMENTO ORIGINALE

Honda	91015-KV6-0030
-------	----------------

◀ **cod. NT06003**
 sigla: TMB204CCS24-1
 misure: 20x47x14
APPLICABILITÀ: Trasmissione
RIFERIMENTO ORIGINALE

Piaggio	82990R
Piaggio	833701

◀ **cod. NT06010**
 sigla: 6206C3
 misure: 30x62x16
APPLICABILITÀ: Carter Motore
RIFERIMENTO ORIGINALE

Yamaha	933062062700
MBK	933062062700

◀ **cod. NT06004**
 sigla: 63/22C3
 misure: 22x56x16
APPLICABILITÀ: Carter Motore
RIFERIMENTO ORIGINALE

Cagiva	800088828	Yamaha	933063720700
MBK	933063720400	Yamaha	993063720300
Yamaha	933063720400		

◀ **cod. NT06011**
 sigla: 6005
 misure: 25x47x12
APPLICABILITÀ: Scatola Ingranaggi
RIFERIMENTO ORIGINALE

Cagiva	751132566
Ducati	751132566
Peugeot	753581

◀ **cod. NT06006**
 sigla: 6303U1
 misure: 17x47x14
APPLICABILITÀ: Trasmissione
RIFERIMENTO ORIGINALE

MBK	933063021200	Yamaha	93306302Y800
Yamaha	933063021200	MBK	933063030200
MBK	93306302Y800	Yamaha	933063030200

◀ **cod. NT06012**
 sigla: 6204T2x3C4
 misure: 20x47x14
APPLICABILITÀ: Carter Motore
RIFERIMENTO ORIGINALE

Kymco	00109225	Malaguti	75106600
Malaguti	10403400	MBK	93306204X200
Italjet	337126018	Yamaha	93306204X200
Italjet	4405102459	MBK	93306204X700
Malaguti	60322800	Yamaha	93306204X700
Malaguti	75105000		

◀ **cod. NT06007**
 sigla: 6006LLUC3/2A
 misure: 30x55x13
APPLICABILITÀ: Ruota
RIFERIMENTO ORIGINALE

Suzuki	08133-60067-000	Aprilia	82659R
Ducati	751623075	Piaggio	82659R

◀ **cod. NT06013**
 sigla: 6301C3
 misure: 12x37x12
APPLICABILITÀ: Carter Motore
RIFERIMENTO ORIGINALE

Italjet	5301510
Sym	961006301300



◀ cod. **NT06014**

sigla: 6303LLUC3/5K
misure: 17x47x14

APPLICABILITÀ: Trasmissione

RIFERIMENTO ORIGINALE

MBK	933062030600	MBK	933063031700
Yamaha	933062030600	Yamaha	933063031700

◀ cod. **NT06020**

sigla: 6201
misure: 12x32x10

APPLICABILITÀ: Trasmissione

RIFERIMENTO ORIGINALE

Kymco	00108211	Italjet	337126016
Italjet	210478261	Malaguti	60324300
Italjet	3341120	Peugeot	706433

◀ cod. **NT06015**

sigla: 6203
misure: 17x40x12

APPLICABILITÀ: Carter Motore

RIFERIMENTO ORIGINALE

Ducati	70240331A
--------	-----------

◀ cod. **NT06021**

sigla: 6205C3
misure: 25x52x15

APPLICABILITÀ: Carter Motore

RIFERIMENTO ORIGINALE

Beta	1295610000	MBK	933063042100
Italjet	3340413	Yamaha	933063042100
Peugeot	724646	MBK	933063044200
MBK	933062052900	Yamaha	933063044200
Yamaha	933062052900		

◀ cod. **NT06016**

sigla: 16005
misure: 25x47x8

APPLICABILITÀ: Scatola Ingranaggi

RIFERIMENTO ORIGINALE

Derbi	007130
Piaggio	007130

◀ cod. **NT06022**

sigla: 6201ZZ/5K
misure: 12x32x10

RIFERIMENTO ORIGINALE

Italjet	5301011
---------	---------

◀ cod. **NT06017**

sigla: 6201C3
misure: 12x32x10

APPLICABILITÀ: Carter Motore

RIFERIMENTO ORIGINALE

Beta	1293456000
------	------------

◀ cod. **NT06023**

sigla: 6302U1
misure: 15x42x13

APPLICABILITÀ: Carter Motore

RIFERIMENTO ORIGINALE

Kymco	00121011	Peugeot	737884
Suzuki	08110-63020-000	Malaguti	75109600
Italjet	5301521	Malaguti	95100900

◀ cod. **NT06018**

sigla: TMB206JR2C3
misure: 30x62x16

APPLICABILITÀ: Albero Motore

RIFERIMENTO ORIGINALE

KTM	0625060206
-----	------------

◀ cod. **NT06024**

sigla: TM-Sx07E39C4
misure: 35x72x17

APPLICABILITÀ: Albero Motore

RIFERIMENTO ORIGINALE

KTM	0625062071
Beta	1299700000

◀ cod. **NT06019**

sigla: 62/22CM
misure: 22x50x14

APPLICABILITÀ: Trasmissione

RIFERIMENTO ORIGINALE

Moto Guzzi	3GAN000051
Italjet	4875102529
Peugeot	755439

◀ cod. **NT06025**

sigla: 6205CC3
misure: 25x52x15

APPLICABILITÀ: Carter Motore

RIFERIMENTO ORIGINALE

Ducati	751202567
--------	-----------



◀ **cod. NT06026**

sigla: 6200C3
misure: 10x30x9

APPLICABILITÀ: Ruota

RIFERIMENTO ORIGINALE

Italjet	3351107
Malaguti	75104700
Honda	96140-620-000

◀ **cod. NT06032**

sigla: 4T-CR-0643L
misure: 30x52x16

APPLICABILITÀ: Cuscinetto Sterzo

RIFERIMENTO ORIGINALE

Suzuki	09265-30014-000
--------	-----------------

◀ **cod. NT06027**

sigla: 6000ZZ/5K
misure: 10x26x8

RIFERIMENTO ORIGINALE

Honda	91051-Z0H-AJ000
-------	-----------------

◀ **cod. NT06033**

sigla: 6002LLU/5K
misure: 15x32x9

APPLICABILITÀ: Ruota

RIFERIMENTO ORIGINALE

Kymco	00121714	Yamaha	93306002Y000
MBK	933060020100	Italjet	9510803
Yamaha	933060020100		

◀ **cod. NT06028**

sigla: SC04A73C3
misure: 22x56x15

APPLICABILITÀ: Scatola Ingranaggi

RIFERIMENTO ORIGINALE

Suzuki	09262-22023-000
--------	-----------------

◀ **cod. NT06034**

sigla: 6205LLUC3/5K
misure: 25x52x15

APPLICABILITÀ: Ruota

RIFERIMENTO ORIGINALE

MBK	933060780600	MBK	933062056700
Yamaha	933060780600	Yamaha	933062056700

◀ **cod. NT06029**

sigla: 6203C3
misure: 17x40x12

APPLICABILITÀ: Carter Motore

RIFERIMENTO ORIGINALE

Kymco	00108019	Italjet	7500047
Italjet	4405102059	Ducati	751201747

◀ **cod. NT06035**

sigla: SF0649Px1
misure: 30x55x17

APPLICABILITÀ: Cuscinetto Sterzo

RIFERIMENTO ORIGINALE

Honda	91016-MB4-7710M1
-------	------------------

◀ **cod. NT06030**

sigla: 63/28C3
misure: 28x68x18

APPLICABILITÀ: Carter Motore

RIFERIMENTO ORIGINALE

Ducati	70240243A
--------	-----------

◀ **cod. NT06036**

sigla: 3TM-Sx06C62CS44
misure: 30x72x16

APPLICABILITÀ: Albero Motore

RIFERIMENTO ORIGINALE

Honda	91001-KRN-6710M1
-------	------------------

◀ **cod. NT06031**

sigla: 6203LLUC3/5K
misure: 17x40x12

RIFERIMENTO ORIGINALE

Italjet	9511106
---------	---------

◀ **cod. NT06037**

sigla: 8E-NK39x58x16-2Px1
misure: 39x58x16

APPLICABILITÀ: Biella

RIFERIMENTO ORIGINALE

Honda	91002-KRN-6710M1
-------	------------------



◀ cod. **NT06038**
 sigla: TM-Sx06C42CS44
 misure: 30x72x19

APPLICABILITÀ: Albero Motore

RIFERIMENTO ORIGINALE

Honda	91001-MBE-6710M1
-------	------------------

◀ cod. **NT06044**
 sigla: SF07A17Px1
 misure: 35x55x14,5

APPLICABILITÀ: Cuscinetto Sterzo

RIFERIMENTO ORIGINALE

Ducati	70240041A
Honda	91016-MR7-0031

◀ cod. **NT06039**
 sigla: 6004LLUC3/5K
 misure: 20x42x12

APPLICABILITÀ: Albero Motore

RIFERIMENTO ORIGINALE

Honda	91009-GEO-004
-------	---------------

◀ cod. **NT06045**
 sigla: 16001JRx
 misure: 12x28x7

APPLICABILITÀ: Scatola Ingranaggi

RIFERIMENTO ORIGINALE

KTM	0625160011
-----	------------

◀ cod. **NT06040**
 sigla: 6005LLUC3/5K
 misure: 25x47x12

APPLICABILITÀ: Ruota

RIFERIMENTO ORIGINALE

Derbi	56205
-------	-------

◀ cod. **NT06046**
 sigla: 6200LLU/5K
 misure: 10x30x9

APPLICABILITÀ: Ruota

RIFERIMENTO ORIGINALE

Italjet	3343003	MBK	933062000900
Italjet	5301015	Yamaha	933062000900

◀ cod. **NT06041**
 sigla: 6304JR2/22CS36
 misure: 22x52x15

APPLICABILITÀ: Carter Motore

RIFERIMENTO ORIGINALE

Beta	1299100000
------	------------

◀ cod. **NT06047**
 sigla: 63/22C4
 misure: 22x56x16

APPLICABILITÀ: Carter Motore

RIFERIMENTO ORIGINALE

Honda	91002-KY4-901
-------	---------------

◀ cod. **NT06042**
 sigla: 3TM-SC04C27CS40
 misure: 20x60x13

APPLICABILITÀ: Albero Motore

RIFERIMENTO ORIGINALE

Piaggio	82671R
---------	--------

◀ cod. **NT06048**
 sigla: 6305JR2CS36
 misure: 25x62x17

APPLICABILITÀ: Albero Motore

RIFERIMENTO ORIGINALE

KTM	0625063055
-----	------------

◀ cod. **NT06043**
 sigla: 8E-NK39x65x18-3
 misure: 39x65x18

APPLICABILITÀ: Biella

RIFERIMENTO ORIGINALE

Honda	91002-MEB-6710M1
-------	------------------

◀ cod. **NT06049**
 sigla: NJ206ET2xCS46
 misure: 30x62x16

APPLICABILITÀ: Motore

RIFERIMENTO ORIGINALE

KTM	50330082000
-----	-------------



◀ **cod. NT06050**

sigla: 6204LLU/5K

misure: 20x47x14

APPLICABILITÀ: Ruota

RIFERIMENTO ORIGINALE

Italjet	3341130
MBK	933062046000
Yamaha	933062046000

◀ **cod. NT06056**

sigla: SF0581Px1

misure: 26x47x15

APPLICABILITÀ: Cuscinetto Sterzo

RIFERIMENTO ORIGINALE

Honda	91015MB4771
-------	-------------

◀ **cod. NT06051**

sigla: 6303LLU/5K

misure: 17x47x14

RIFERIMENTO ORIGINALE

Italjet	210432305
---------	-----------

◀ **cod. NT06057**

sigla: SC04B19CS30Px1/3AS

misure: 20x56x12

APPLICABILITÀ: Albero Motore

RIFERIMENTO ORIGINALE

Honda	91005GW3961
-------	-------------

◀ **cod. NT06052**

sigla: 6305C3

misure: 25x62x17

APPLICABILITÀ: Carter Motore

RIFERIMENTO ORIGINALE

Cagiva	800016794
MBK	933063053600
Yamaha	933063053600

◀ **cod. NT06058**

sigla: TM-SC03A39CS20

misure: 17x42x13

APPLICABILITÀ: Albero Motore

RIFERIMENTO ORIGINALE

Piaggio	96925R
---------	--------

◀ **cod. NT06053**

sigla: TMB207x46JR2CS32-2Px35

RIFERIMENTO ORIGINALE

Honda	91006-KGF-9110
-------	----------------

◀ **cod. NT06059**

sigla: 6303C3

misure: 17x47x14

APPLICABILITÀ: Albero Motore

RIFERIMENTO ORIGINALE

Italjet	337126019
---------	-----------

◀ **cod. NT06054**

sigla: 6204LLUC3/5K

misure: 20x47x14

APPLICABILITÀ: Ruota

RIFERIMENTO ORIGINALE

Italjet	210434735	MBK	933062042200
Italjet	337126017	Yamaha	933062042200
Malaguti	60324400	MBK	933062044600-M
Husqvarna	800015659	Yamaha	933062044600
MBK	933062004Y400	MBK	933062045800
MBK	933062041700	MBK	933062046100
Yamaha	933062041700	MBK	933062046900
MBK	933062042000	Yamaha	93306204Y400
Yamaha	933062042000	MBK	93306204YH00
MBK	933062042100	Yamaha	93306204YH00-

◀ **cod. NT06060**

sigla: 6203LLU/5K

misure: 17x40x12

APPLICABILITÀ: Trasmissione

RIFERIMENTO ORIGINALE

MBK	93306203Y800
Yamaha	93306203Y800

◀ **cod. NT06055**

sigla: SF07A22Px1

misure: 35x55x14,5

APPLICABILITÀ: Cuscinetto Sterzo

RIFERIMENTO ORIGINALE

Piaggio	8110077
Aprilia	AP8110077

◀ **cod. NT06061**

sigla: 6201LLU/5K

misure: 12x32x10

APPLICABILITÀ: Distribuzione

RIFERIMENTO ORIGINALE

Malaguti	11941100
Ducati	751661238



◀ cod. **NT06062**

sigla: 6302LLU/5K
misure: 15x42x13

APPLICABILITÀ: Ruota

RIFERIMENTO ORIGINALE

MBK	933063020200	MBK	933063021200
Yamaha	933063020200	Yamaha	933063021200

◀ cod. **NT06068**

sigla: 6202C3
misure: 15x35x11

APPLICABILITÀ: Carter Motore

RIFERIMENTO ORIGINALE

Peugeot	722669
Honda	961006202300

◀ cod. **NT06063**

sigla: 6004LLU/5K
misure: 20x42x12

APPLICABILITÀ: Ruota

RIFERIMENTO ORIGINALE

Italjet	5302008
Cagiva	800039651

◀ cod. **NT06069**

sigla: 6202LLUC3/5K
misure: 15x35x11

APPLICABILITÀ: Ruota

RIFERIMENTO ORIGINALE

Beta	1294005000	MBK	933062020500
Derbi	58020200	Yamaha	933062020500
Peugeot	750578	Yamaha	933062020900
MBK	9330620203BL	MBK	933062022600
Yamaha	9330620203BL	Yamaha	933062022600
MBK	933062020400	Yamaha	933062020400
Yamaha	933062020400		

◀ cod. **NT06064**

sigla: 6201LLUC3/5K
misure: 12x32x10

APPLICABILITÀ: Ruota

RIFERIMENTO ORIGINALE

Italjet	5301012
Ducati	70250161A
Honda	961406200010

◀ cod. **NT06070**

sigla: TM-SC07A87CS32Px11
misure: 35x72x15

APPLICABILITÀ: Albero Motore

RIFERIMENTO ORIGINALE

Honda	91005KGF911
-------	-------------

◀ cod. **NT06065**

sigla: 6204C3
misure: 20x47x14

APPLICABILITÀ: Carter Motore

RIFERIMENTO ORIGINALE

Italjet	337126018	MBK	93306204Y00
Cagiva	738220425	Yamaha	93306204Y00
Husqvarna	800085380	Yamaha	933063043900
Yamaha	933062045400	MBK	933063044200
MBK	933062046100	Yamaha	933063044200
Yamaha	933062046100	Italjet	9510208
Yamaha	933062046800		

◀ cod. **NT06071**

sigla: 6204JR2C4
misure: 20x47x14

APPLICABILITÀ: Carter Motore

RIFERIMENTO ORIGINALE

KTM	0625062041
Beta	1298501000
Italjet	4405102459

◀ cod. **NT06066**

sigla: SC05B61CS35Px1/2AS
misure: 25x56x12

APPLICABILITÀ: Albero Motore

RIFERIMENTO ORIGINALE

Honda	961006202300
-------	--------------

◀ cod. **NT06072**

sigla: 3TM-SC05B31CS37
misure: 25x68x12

APPLICABILITÀ: Albero Motore

RIFERIMENTO ORIGINALE

Piaggio	483970
---------	--------

◀ cod. **NT06067**

sigla: 6202LLU/5K
misure: 15x35x11

APPLICABILITÀ: Ruota

RIFERIMENTO ORIGINALE

Moto Guzzi	92230320
------------	----------

◀ cod. **NT06073**

sigla: SC04A47CS29Px1
misure: 20x52x12

APPLICABILITÀ: Albero Motore

RIFERIMENTO ORIGINALE

Piaggio	431125
Peugeot	722483



◀ cod. **NT06074**
sigla: 6200U1

◀ cod. **NT06082**
sigla: 6301LLU/5K

◀ cod. **NT06075**
sigla: 4T-30205

◀ cod. **NT06083**
sigla: SC05A12

◀ cod. **NT06076**
sigla: 4T-320/28x

◀ cod. **NT06084**
sigla: 6204
misure: 20x47x14

APPLICABILITÀ: Carter Motore
RIFERIMENTO ORIGINALE

Suzuki	09262-20069-000
Suzuki	09262-20121-000

◀ cod. **NT06077**
sigla: 4T-32006x

◀ cod. **NT06086**
sigla: 6302LLUC3/5K

◀ cod. **NT06078**
sigla: 4T-32007x

◀ cod. **NT06087**
sigla: 6000LLU/5K
APPLICABILITÀ: Distribuzione

RIFERIMENTO ORIGINALE

Yamaha	933063042100
MBK	933063042100

◀ cod. **NT06079**
sigla: 60/22LLU/5K

◀ cod. **NT06088**
sigla: 6003LLUC3/5K
misure: 17x35x10

RIFERIMENTO ORIGINALE

Suzuki	24123-89010-000
Ducati	70250014A
Ducati	70250015A

◀ cod. **NT06080**
sigla: 6000
misure: 30x52x16

◀ cod. **NT06089**
sigla: 6305
misure: 25x62x17

APPLICABILITÀ: Albero Motore
RIFERIMENTO ORIGINALE

Yamaha	933063054300
Yamaha	933063055600

◀ cod. **NT06081**
sigla: 6207C3



◀ cod. **FA10100**
Filtro Aria Kymco Dink 125/150 cc 02-07

APPLICABILITÀ

KYMCO DINK CLASSIC 125 4T 02-02, DINK CLASSICEU2 125 4T 03-03, DINK LX 125 4T 98-00, DINK CLASSIC 150 4T 02-02, DINK CLASSICEU2 150 4T 03-03, DINK LX 150 4T 98-00, DINK CLASSIC 200 4T 04-04

RIFERIMENTO ORIGINALE

Kymco	162993
-------	--------



◀ cod. **FA10101**
Filtro Aria Kymco Dink 50 cc 4T

APPLICABILITÀ

KYMCO AGILITY R16 50 4T 08-09, AGILITY R16 50 4T 12-12, DINK 50 4T 50 4T 07-07, PEOPLE S 4T 50 4T 06-08, SENTO 50 4T 08-08, SUPER 8 4T 50 4T 07-07, SUPER 8 4T 50 4T 09-09, SUPER 8 4T 50 4T 13-13

RIFERIMENTO ORIGINALE

Kymco	101074
-------	--------



◀ cod. **FA10102**
Filtro Aria Honda SH 125/150 cc

APPLICABILITÀ

HONDA @ [NES] 125 4T 00-06, DYLAN [SES] 125 4T 02-04, PS I [PES] 125 4T 06-10, SH 125 4T-2V 01-04, SH IE SCOOOPY 125 4T-2V 05-12, @ [NES] 150 4T 00-06, DYLAN [SES] 150 4T 02-04, PS I [PES] 150 4T 06-10, SH 150 4T-2V 01-04

RIFERIMENTO ORIGINALE

Honda	17210-KGF-900
-------	---------------



◀ cod. **FA10103**
Filtro Aria Honda Foresight 250 cc

APPLICABILITÀ

HONDA FORESIGHT [FES] 250 4T 98-99, FORESIGHT [FES] D.D. 250 4T 00-05, JAZZ ES REFLEX (NSS) 250 4T-2V 01-04, JAZZ REFLEX(NSS) 250 4T-2V 01-01

RIFERIMENTO ORIGINALE

Honda	17210-KGF-900
-------	---------------



◀ **cod. FA10104**
Filtro Aria Kymco Agility 125-150cc R16

APPLICABILITÀ

KYMCO FILLY LX 50 4T 01-02, PEOPLE S 50 2T 05-08, AGILITY PLUS 125 4T 14-14, AGILITY R16 125 4T 08-09, AGILITY R16 125 4T 12-12, PEOPLE 125 4T 99-00, PEOPLE EU2 125 4T 03-03, PEOPLE EU3 125 4T 07-08, PEOPLE EU3 125 4T 11-11, PEOPLE ONE I 125 4T 13-13, PEOPLE S DD EU3 125 4T 07-08, SUPER 8 125 4T 08-09, AGILITY R16 150 4T 08-09, PEOPLE 150 4T 99-00, PEOPLE EU2 150 4T 03-03, AGILITY I PLUS 200 4T 14-14, AGILITY R16 200 4T 12-12, AGILITY R16 200 4T 10-10, PEOPLE S 200 4T 05-05, PEOPLE S I 200 4T 07-07

RIFERIMENTO ORIGINALE

Kymco	162377
-------	--------

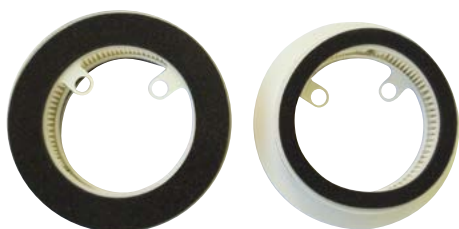

◀ **cod. FA10105**
Filtro Aria Cinghia DX Yamaha T-MAX 500cc 01-11

APPLICABILITÀ

YAMAHA T-MAX 4BS 500 4T 09-11, T-MAX 4BS ABS 500 4T 08-11, T-MAX 5GJ 500 4T 01-03, T-MAX 5VU 500 4T 04-08, T-MAX 5VU ABS 500 4T 05-07, T-MAX 5VU BLACK MAX 500 4T 06-06, T-MAX 5VU BLACK MAX - NIGHT MAX 500 4T 07-07

RIFERIMENTO ORIGINALE

Yamaha	5GJ154080000
--------	--------------



◀ **cod. FA10106**
Filtro Aria Yamaha T-MAX 500cc 01-07

APPLICABILITÀ

YAMAHA T-MAX 5GJ 500 4T 01-03, T-MAX 5VU 500 4T 04-07, T-MAX 5VU ABS 500 4T 05-07, T-MAX 5VU BLACK MAX 500 4T 06-06, T-MAX 5VU BLACK MAX - NIGHT MAX 500 4T 07-07

RIFERIMENTO ORIGINALE

Yamaha	4BH144510100
--------	--------------

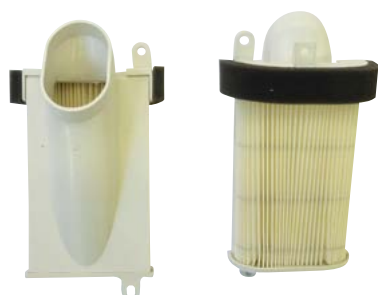

◀ **cod. FA10107**
Filtro Aria Cinghia SX Yamaha T-MAX 500cc 01-07

APPLICABILITÀ

YAMAHA T-MAX 5GJ 500 4T 01-03, T-MAX 5VU 500 4T 04-07, T-MAX 5VU ABS 500 4T 05-07, T-MAX 5VU BLACK MAX 500 4T 06-06, T-MAX 5VU BLACK MAX - NIGHT MAX 500 4T 07-07

RIFERIMENTO ORIGINALE

Yamaha	5GJ154070100
--------	--------------



◀ cod. **FA10109**
Filtro Aria Kymco Dink 125cc EU3 06-10

APPLICABILITÀ

KYMCO DINK EU3 125 4T 06-07, GRAND DINK 125 4T 01-02, GRAND DINK EU2 125 4T 03-04, GRAND DINK 150 4T 01-02, GRAND DINK EU2 150 4T 03-04, DINK IE EU3 200 4T 06-07, GRAND DINK 250 4T 01-02, GRAND DINK EU2 250 4T 03-04, X CITING 250 4T 05-05, X CITING I 250 4T 06-07, X CITING I 300 4T 08-08, X CITING I R 300 4T 08-09

RIFERIMENTO ORIGINALE

Kymco	162475
-------	--------



◀ cod. **FA10110**
Filtro Aria Kymco People S 250cc 06-09

APPLICABILITÀ

KYMCO PEOPLE LC 250 4T 03-04, PEOPLE S 250 4T 06-06, PEOPLE S I 250 4T 07-07, PEOPLE S I 300 4T 08-08

RIFERIMENTO ORIGINALE

Kymco	162380
-------	--------



◀ cod. **FA10111**
Filtro Aria Kymco Agility 50cc 4T R12 05-10

APPLICABILITÀ

KYMCO AGILITY 4T CARRY 50 4T 11-11, AGILITY 4T R12 50 4T 07-08, AGILITY R12 50 4T 05-05, AGILITY RS 50 4T 09-09, DINK CLASSIC EU2 50 2T 03-03

RIFERIMENTO ORIGINALE

Kymco	164044
-------	--------



◀ cod. **FA10112**
Filtro Aria Kymco Agility 50cc 4T R10 06-10

APPLICABILITÀ

KYMCO AGILITY 4T R10 50 4T 06-08

RIFERIMENTO ORIGINALE

Kymco	163126
-------	--------



◀ **cod. FA10113**
Filtro Aria Variatore Yamaha Majesty 250 cc

APPLICABILITÀ

MALAGUTI PASSWORD 250 4T 05-06, PASSWORD EU3 250 4T 07-08

YAMAHA MAJESTY 250 4T 00-03, MAJESTY ABS 250 4T 03-03, X-CITY 250 4T 07-15, X-MAX 250 4T 05-16, X-MAX ABS 250 4T 11-12, X-MAX ABS 250 4T 14-15, X-MAX BLACK 250 4T 09-09, X-MAX SPORT 250 4T 11-12, VERSITY 300 4T 03-06

RIFERIMENTO ORIGINALE

Yamaha	5GM154070000
--------	--------------



◀ **cod. FA10115**
Filtro Aria Yamaha X-MAX 250 cc 05-10

APPLICABILITÀ

YAMAHA X-CITY EU3 125 4T-4V 08-11, X-MAX R 125 4T-4V 06-16, X-MAX R ABS 125 4T-4V 11-11, X-MAX RA ABS 125 4T-4V 13-16, X-CITY 250 4T 07-15, X-MAX 250 4T 05-16, X-MAX ABS 250 4T 11-12, X-MAX ABS 250 4T 14-15, X-MAX BLACK 250 4T 09-09, X-MAX SPORT 250 4T 11-12

RIFERIMENTO ORIGINALE

Yamaha	1B9144510000
--------	--------------



◀ **cod. FA10116**
Filtro Aria Honda SH 300 cc i.e.

APPLICABILITÀ

Honda SH IE 300 Scoopy 300 4T-4V 07-12

RIFERIMENTO ORIGINALE

Honda	17210-KTW-900
-------	---------------



◀ **cod. FA10119**
Filtro Aria Sym Joymax 250/300 cc

APPLICABILITÀ

SYM GTS 250 4T-4V 07-08, JOYMAX 250 4T-4V 05-07, JOYMAX EU3 I 250 4T-4V 07-08, JOYMAX EVO 300 4T-4V 09-09, JOYMAX EVO I 300 4T-4V 10-10, JOYMAX I 300 4T-4V 12-12, JOYMAX I 300 4T-4V 14-14, JOYMAX I ABS 300 4T-4V 13-13

RIFERIMENTO ORIGINALE

Sym	17211HMA000
-----	-------------

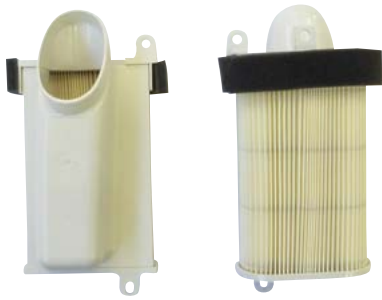

◀ cod. **FA10120**
Filtro Aria Cinghia SX Yamaha T-MAX 500 cc 08-11

APPLICABILITÀ

YAMAHA T-MAX 4BS 500 4T 09-11, T-MAX 4BS ABS 500 4T 08-11, T-MAX 5VU 500 4T 08-08

RIFERIMENTO ORIGINALE

Yamaha	4B5154070000
--------	--------------



◀ cod. **FA10121**
Filtro Aria SX Yamaha Majesty 400 cc 04-10

APPLICABILITÀ

YAMAHA MAJESTY 400 4T 04-11, MAJESTY ABS 400 4T 07-11

RIFERIMENTO ORIGINALE

Yamaha	5RU144513000
--------	--------------



◀ cod. **FA10122**
Filtro Aria Suzuki Burgman 125/200 cc 07-10

APPLICABILITÀ

SUZUKI UH BURGMAN K7/LO 125 4T 07-10, UH BURGMAN L1 125 4T 11-11, UH BURGMAN L3 125 4T 13-13, UH BURGMAN L4 125 4T 14-14, UH BURGMAN K7/LO 200 4T 07-10, UH BURGMAN L1 200 4T 11-12, UH BURGMAN L3 200 4T 13-13, UH BURGMAN L4 200 4T 14-14

RIFERIMENTO ORIGINALE

Suzuki	13780-03H00-000
--------	-----------------



◀ cod. **FA10123**
Filtro Aria Kymco Downtown 300 cc

APPLICABILITÀ

KYMCO DOWNTOWN ABS 300 4T 10-10, DOWNTOWN I 300 4T 09-09, DOWNTOWN I 300 4T 11-11, DOWNTOWN I ABS 300 4T 11-16

RIFERIMENTO ORIGINALE

Kymco	117245
-------	--------



◀ cod. **FA10124**
Filtro Aria Honda PCX 125 cc

APPLICABILITÀ

HONDA PCX 125 4T-2V 10-11, PCX 125 4T-2V 13-13, PCX 150 4T-2V 13-17

RIFERIMENTO ORIGINALE

Honda	17210-KMN-900
-------	---------------

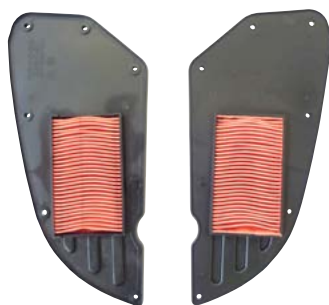

◀ cod. **FA10126**
Filtro Aria Kymco DOWNTOWN 125 cc

APPLICABILITÀ

KYMCO DOWNTOWN I 125 4T 09-16, DOWNTOWN I 200 4T 10-10

RIFERIMENTO ORIGINALE

Kymco	117199
-------	--------



◀ cod. **FA10127**
Filtro Aria Honda S-WING 125/150 cc 4T

APPLICABILITÀ

HONDA SILVER WING [FES] 125 4T-2V 07-12, SILVER WING [FES] 150 4T-2V 07-12

RIFERIMENTO ORIGINALE

Honda	17210-KRJ-900
-------	---------------



◀ cod. **FA10128**
Filtro Aria Cinghia SX Yamaha T-MAX 530 cc

APPLICABILITÀ

YAMAHA T-MAX 59C 530 4T 12-16, T-MAX 59C ABS 530 4T 12-16, T-MAX 59C SP 530 4T 15-15, T-MAX 59C SP ABS 530 4T 15-16

RIFERIMENTO ORIGINALE

Yamaha	59C154070000
--------	--------------



◀ cod. **FA10129**
Filtro Aria Cinghia DX Yamaha T-MAX 530 cc

APPLICABILITÀ

YAMAHA T-MAX 59C 530 4T 12-16, T-MAX 59C ABS 530 4T 12-16, T-MAX 59C SP 530 4T 15-15, T-MAX 59C SP ABS 530 4T 15-16, XP530-A T-MAX SX 530 4T 17-19, XP530D-A T-MAX DX 530 4T 17-19, XP530E-A T-MAX 530 4T 17-18

RIFERIMENTO ORIGINALE

Yamaha	59C154080000
--------	--------------



◀ cod. **F007510**



◀ cod. **F007511**



◀ cod. **F007512**



◀ cod. **F007513**



◀ cod. **F007514**



◀ cod. **F007515**



◀ cod. **F007516**



◀ cod. **F007517**



◀ cod. **F007519**



◀ cod. **F007520**



◀ cod. **F007521**



◀ cod. **F007522**



◀ cod. **F007523**



◀ cod. **F007524**

Marca	Modello	CC	Anno	Codice
APRILIA	ATLANTIC	125	2003>2005	F007515
	ATLANTIC	200	2003>2005	F007515
	ATLANTIC	250	2003>2005	F007515
	ATLANTIC	300	2010>2011	F007515
	ATLANTIC	500	2001>2004	F007524
	ATLANTIC ARRECIFE	125	2003>2005	F007515
	ATLANTIC ARRECIFE	200	2003>2005	F007515
	ATLANTIC ARRECIFE	250	2003>2005	F007515
	ATLANTIC ARRECIFE	400	2005>2008	F007524
	ATLANTIC ARRECIFE	500	2005>2008	F007524
	ATLANTIC EU3	125	2006>2008	F007515
	ATLANTIC EU3	125	2010>2012	F007515
	ATLANTIC EU3	250	2006>2008	F007515
	ATLANTIC SPRINT	400	2005>2008	F007524
	ATLANTIC SPRINT	500	2005>2008	F007524
	LEONARDO	125	1996>1998	F007516
	LEONARDO	125	1999>2002	F007516
	LEONARDO	150	1996>1998	F007516
	LEONARDO	150	1999>2002	F007516
	LEONARDO ST	125	2003>2004	F007516
	MOJITO	125	2003>2007	F007515
	MOJITO	125	2008>2008	F007515
	MOJITO	150	2003>2007	F007515
	MOJITO RETRO' CUSTOM	125	1999>2001	F007514
	SCARABEO	125	1999>2003	F007516
	SCARABEO	125	2003>2003	F007515
	SCARABEO	125	2004>2006	F007515
	SCARABEO	150	1999>2003	F007516
	SCARABEO	150	2004>2006	F007515
	SCARABEO	200	2001>2003	F007516
	SCARABEO	200	2003>2003	F007515
	SCARABEO	250	2004>2006	F007515
SCARABEO	500	2003>2006	F007524	
SCARABEO EU3	125	2006>2007	F007515	
SCARABEO EU3	200	2006>2006	F007515	
SCARABEO LIGHT	250	2006>2008	F007515	
SCARABEO LIGHT	300	2009>2010	F007515	
SCARABEO LIGHT	400	2006>2008	F007524	
SCARABEO LIGHT	500	2006>2008	F007524	
SPORT CITY	125	2004>2006	F007515	

Marca	Modello	CC	Anno	Codice	
APRILIA	SPORT CITY	200	2004>2006	F007515	
	SPORT CITY CUBE	125	2008>2010	F007515	
	SPORT CITY CUBE	200	2008>2010	F007515	
	SPORT CITY CUBE	250	2008>2012	F007515	
	SPORT CITY CUBE	300	2008>2010	F007515	
	SPORT CITY EU3	125	2006>2008	F007515	
	SPORT CITY EU3	200	2006>2008	F007515	
	SPORT CITY EU3	250	2006>2008	F007515	
	SPORT CITY ONE 4T EU3	125	2008>2011	F007515	
	SPORT CITY STREET	125	2012>2012	F007515	
	SPORT CITY STREET	300	2012>2012	F007515	
	SR MAX	125	2011>2014	F007515	
	SR MAX	300	2011>2014	F007515	
	SR MOTARD	125	2012>2014	F007515	
	BENELLI	ADIVA	125	2001>2002	F007515
		ADIVA	150	2001>2002	F007515
		ADIVA EU2	250	2006>2008	F007515
VELVET DUSK	400	2003>2004	F007510		
BETA	RR	125	2010>2017	F007523	
BMW	C1	125	2000>2003	F007516	
	C1	200	2002>2003	F007516	
DERBI	BOULEVARD	125	2002>2002	F007515	
	BOULEVARD	125	2003>2004	F007515	
	BOULEVARD	150	2002>2002	F007515	
	BOULEVARD	150	2003>2004	F007515	
	BOULEVARD 4T E3	150	2010>2010	F007515	
	BOULEVARD 4T EU3	125	2008>2012	F007515	
	BOULEVARD EU2	125	2004>2007	F007515	
	BOULEVARD EU2	200	2005>2006	F007515	
	BOULEVARD EU3	150	2004>2007	F007515	
	GP1	250	2006>2007	F007515	
	GP1 EU 2	125	2006>2006	F007515	
	GP1 LOW SEAT EU3	125	2007>2008	F007515	
	GP1 LOW SEAT EU3	250	2007>2008	F007515	
	RAMBLA	125	2008>2009	F007515	
	RAMBLA	250	2008>2009	F007515	
RAMBLA	300	2010>2011	F007515		
RAMBLA EU3 2VER	125	2008>2008	F007515		
RAMBLA EU3 2VER	250	2008>2008	F007515		

Marca	Modello	CC	Anno	Codice
DERBI	SONAR 4T	125	2009>2011	F007515
	SONAR 4T	150	2009>2009	F007515
	VARIANT SPORT 4T EU3	125	2012>2012	F007515
FANTIC	CABALLERO MOTARD	125	2008>2018	F007523
	CABALLERO REGOLARITÀ	125	2008>2008	F007523
GILERA	DNA	125	2001>2001	F007515
	DNA	180	2001>2001	F007515
	FUOCO 4T-4V IE E3 LT	500	2013>2014	F007524
	FUOCO IE EU3	500	2007>2013	F007524
	GP	800	2007>2008	F007524
	GP	800	2009>2011	F007524
	GP CENTENARIO	800	2009>2009	F007524
	NEXUS	500	2003>2005	F007524
	NEXUS EU3	125	2007>2008	F007515
	NEXUS EU3	250	2006>2006	F007515
	NEXUS EU3	250	2007>2007	F007515
	NEXUS EU3	300	2008>2008	F007515
	NEXUS EU3	300	2009>2011	F007515
	NEXUS EU3	500	2006>2008	F007524
	NEXUS EU3	500	2009>2011	F007524
	NEXUS IE EU3	125	2008>2008	F007515
	NEXUS IE EU3	125	2009>2010	F007515
	NEXUS SP EU3	250	2006>2007	F007515
	NEXUS SP EU3	500	2006>2007	F007524
	RUNNER	180	2000>2001	F007515
RUNNER 4T ST EU3	125	2008>2016	F007515	
RUNNER VX	125	2000>2001	F007515	
RUNNER VX	125	2002>2004	F007515	
RUNNER VX	125	2005>2006	F007515	
RUNNER VX 4T EU3	125	2006>2007	F007515	
RUNNER VX RACE	125	2006>2006	F007515	
RUNNER VX SC	125	2006>2007	F007515	
RUNNER VXR	180	2000>2001	F007515	
RUNNER VXR	200	2002>2004	F007515	
RUNNER VXR	200	2005>2006	F007515	
RUNNER VXR 4T ST EU3	200	2008>2011	F007515	
RUNNER VXR EU3	200	2007>2007	F007515	
RUNNER VXR RACE 200	125	2006>2006	F007515	
HM	CITY	125	2011>2013	F007523
	CITY	200	2011>2013	F007523

Marca	Modello	CC	Anno	Codice
HM	CRE F125X	125	2008>2009	F007523
	CRE F125X BAJA	125	2010>2012	F007523
	CRE F125X SIX	125	2010>2011	F007523
	CRM F125X	125	2008>2009	F007523
	CRM F125X DERAPAGE	125	2010>2012	F007523
	CRM F125X DERAPAGE COMPETITION	125	2010>2011	F007523
	CRM F125X DERAPAGE RR	125	2010>2012	F007523
	LOCUSTA	125	2011>2013	F007523
	LOCUSTA	200	2011>2013	F007523
	HONDA	CBR 600 F	600	1998>1998
FORZA		300	2013>2017	F007513
FORZA EURO 4		300	2018>2020	F007513
FORZA [NSS A]		250	2008>2011	F007513
FORZA [NSS S]		250	2008>2011	F007513
SH IE SCOOPY		300	2007>2010	F007513
SH IE SCOOPY		300	2011>2019	F007513
SILVER WING [FJS]		400	2006>2008	F007513
SILVER WING [FJS]		600	2001>2010	F007513
SW-T [FJS]		400	2009>2013	F007513
SW-T [FJS]		600	2011>2013	F007513
HUSQVARNA		SM	125	2010>2010
	TE	125	2010>2010	F007523
ITALJET	JET SET	125	2001>2001	F007515
	JET SET	150	2001>2001	F007515
	TORPEDO	125	1999>2002	F007515
	TORPEDO	150	1999>2002	F007515
MALAGUTI	MADISON 3	125	2006>2009	F007515
	MADISON 3	250	2006>2009	F007515
	MADISON R	180	2001>2002	F007515
	MADISON RS	250	2004>2004	F007515
	MADISON S RESTYLING	200	2002>2002	F007515
	PHANTOM MAX	200	2003>2003	F007515
	PHANTOM MAX	250	2004>2004	F007515
	SPIDER MAX GT	500	2004>2005	F007524
SPIDER MAX GT EU3	500	2006>2006	F007524	
SPIDER MAX RS	500	2008>2008	F007524	
MBK	CITYLINER EU3	125	2008>2010	F007523
	SKYCRUISER	125	2007>2007	F007523
MOTORHISPANIA	KN1	125	2008>2008	F007523
	MH7	125	2008>2008	F007523

Marca	Modello	CC	Anno	Codice
MOTORHISPANIA	RX-R	125	2008>2008	F007523
PEUGEOT	GEOPOLIS IE EU3	250	1990>2002	F007515
	GEOPOLIS IE EU3	400	1990>2002	F007524
	GEOPOLIS IE EU3	500	1990>2002	F007524
	SATELIS EU3	250	1990>2002	F007515
	SATELIS EU3	400	2007>2012	F007524
	SATELIS EU3	500	1990>2002	F007524
PIAGGIO	BEVERLY	125	2001>2003	F007515
	BEVERLY	200	2001>2003	F007515
	BEVERLY	250	2005>2007	F007515
	BEVERLY	500	2002>2004	F007524
	BEVERLY	500	2005>2006	F007524
	BEVERLY EU3	400	2006>2007	F007524
	BEVERLY CRUISER	250	2007>2009	F007515
	BEVERLY CRUISER	500	2007>2012	F007524
	BEVERLY EU3	125	2007>2008	F007515
	BEVERLY EURO 3 MIC	125	2007>2007	F007515
	BEVERLY EURO 3 MIC	250	2007>2007	F007515
	BEVERLY EURO 3 SPORT	125	2007>2008	F007515
	BEVERLY IE EU3	250	2006>2008	F007515
	BEVERLY IE EU3	500	2006>2008	F007524
	BEVERLY RST	125	2004>2005	F007515
	BEVERLY RST	125	2005>2007	F007515
	BEVERLY RST	250	2004>2005	F007515
	BEVERLY RST 4T 4V IE EU3	125	2010>2015	F007515
	BEVERLY RST 4T 4V IE EU3	300	2010>2016	F007515
	BEVERLY SPORT	250	2006>2008	F007515
	BEVERLY TOURER EU3	125	2007>2010	F007515
	BEVERLY TOURER EU3	250	2007>2009	F007515
	BEVERLY TOURER EU3	300	2009>2010	F007515
	BEVERLY TOURER EU3	400	2008>2010	F007524
	CARNABY	125	2007>2010	F007515
	CARNABY	200	2007>2008	F007515
	CARNABY	250	2008>2009	F007515
	CARNABY CRUISER	300	2009>2012	F007515
	FLY	125	2005>2007	F007515
	FLY	150	2005>2007	F007515
	FLY EU3	125	2007>2007	F007515
	FLY EU3	125	2008>2011	F007515
	FLY EU3	150	2008>2011	F007515

Marca	Modello	CC	Anno	Codice
PIAGGIO	HEXAGON GTX	125	2000>2000	F007515
	HEXAGON GTX	180	2000>2000	F007515
	HEXAGON LX4	125	1998>1999	F007514
	LIBERTY	125	1998>2000	F007514
	LIBERTY	125	2001>2002	F007515
	LIBERTY	150	2001>2002	F007515
	LIBERTY	200	2006>2006	F007515
	LIBERTY 4T	125	2006>2007	F007515
	LIBERTY 4T 2V EURO3	125	2009>2012	F007515
	LIBERTY 4T EU3	125	2006>2008	F007515
	LIBERTY 4T EU3	200	2006>2008	F007515
	LIBERTY 4T EU3 DELIVERY - TNT	125	2008>2015	F007515
	LIBERTY 4T SPORT EU3	125	2006>2008	F007515
	LIBERTY 4T SPORT EU3	150	2008>2008	F007515
	LIBERTY 4T SPORT EU3	200	2006>2007	F007515
	LIBERTY MOC 4T	150	2009>2013	F007515
	LIBERTY RST	125	2004>2005	F007515
	LIBERTY RST	200	2004>2004	F007515
	LIBERTY RST PTT	125	2005>2011	F007515
	LIBERTY SPORT	125	2006>2006	F007515
	LIBERTY SPORT	200	2006>2006	F007515
	MP3	125	2006>2008	F007515
	MP3	250	2006>2008	F007515
	MP3	400	2007>2008	F007524
	MP3 4T 4V IE LT IBRIDO	300	2010>2011	F007515
	MP3 IBRIDO	125	2009>2010	F007515
	MP3 IE	125	2008>2009	F007515
	MP3 IE LT	300	2010>2011	F007515
	MP3 IE LT TOURING	300	2011>2013	F007515
	MP3 IE LT TOURING	400	2011>2011	F007524
	MP3 IE LT/SPORT	300	2011>2014	F007515
	MP3 IE LT/SPORT	400	2008>2010	F007524
	MP3 IE MIC	300	2010>2010	F007515
	MP3 IE MIC	300	2011>2011	F007515
	MP3 IE TOURING	125	2011>2012	F007515
	MP3 IE TOURING	300	2011>2012	F007515
	MP3 LT	250	2008>2009	F007515
	MP3 LT BUSINESS ABS	500	2014>2016	F007524
	MP3 LT SPORT/BUSINESS	500	2011>2013	F007524
	MP3 MIC	250	2008>2009	F007515

Marca	Modello	CC	Anno	Codice
PIAGGIO	MP3 MIC	400	2008>2010	F007524
	MP3 RL SPORT-BUSINESS	500	2011>2012	F007524
	MP3 RL TOURING	400	2011>2011	F007524
	MP3 SPORT ABS	500	2014>2016	F007524
	MP3 YOURBAN ERL	125	2011>2013	F007515
	MP3 YOURBAN ERL	300	2011>2015	F007515
	MP3 YOURBAN LT ERL	300	2011>2012	F007515
	SFERA	125	1995>1997	F007514
	SKYPPER 4T	125	2000>2002	F007515
	SKYPPER 4T	150	2000>2002	F007515
	SUPER HEXAGON GTX 12	125	2001>2002	F007515
	SUPER HEXAGON GTX 12	180	2001>2002	F007515
	TYPHOON 4T 2V E3	125	2010>2011	F007515
	VESPA ET4	125	1996>1998	F007514
	VESPA ET4	125	1999>2002	F007515
	VESPA ET4	150	1999>2002	F007515
	VESPA GRANTURISMO	125	2003>2005	F007515
	VESPA GRANTURISMO	125	2006>2007	F007515
	VESPA GRANTURISMO	200	2003>2005	F007515
	VESPA GRANTURISMO	200	2006>2007	F007515
	VESPA GRANTURISMO EU3	125	2006>2007	F007515
	VESPA GT 60 EU3	250	2006>2007	F007515
	VESPA GTS	250	2005>2016	F007515
	VESPA GTS 4T IE SUPER	125	2009>2016	F007515
	VESPA GTS ABS	250	2005>2012	F007515
	VESPA GTS EU3	125	2007>2012	F007515
	VESPA GTS IETOURING	300	2011>2012	F007515
	VESPA GTS SUPER	300	2008>2016	F007515
	VESPA GTS SUPER SPORT	300	2010>2013	F007515
	VESPA GTV	125	2006>2008	F007515
	VESPA GTV	250	2006>2009	F007515
	VESPA GTV 4T 4V IE	300	2010>2013	F007515
	VESPA GTV 4T NAVY EU3	125	2008>2008	F007515
	VESPA GTV 4T NAVY EU3	250	2007>2007	F007515
	VESPA GTV VIA MONTENAPOLIONE	300	2010>2010	F007515
	VESPA LX	125	2005>2006	F007515
	VESPA LX	150	2005>2006	F007515
	VESPA LX 4T EU3 TOURING	125	2010>2011	F007515
	VESPA LX 4T FL	125	2009>2009	F007515
	VESPA LX 4T FL	150	2009>2009	F007515

Marca	Modello	CC	Anno	Codice
PIAGGIO	VESPA LX EU3	125	2006>2008	F007515
PIAGGIO	VESPA LX EU3	150	2006>2008	F007515
PIAGGIO	VESPA LX EU3 IE	125	2009>2011	F007515
PIAGGIO	VESPA LX EU3 IE	150	2009>2011	F007515
PIAGGIO	VESPA LX TOURING	150	2010>2012	F007515
PIAGGIO	VESPA LXV 4T EU3	125	2006>2009	F007515
PIAGGIO	VESPA LXV IE 4T	125	2010>2013	F007515
PIAGGIO	VESPA LXV NAVY EU3	125	2007>2008	F007515
PIAGGIO	VESPA S 4T	150	2008>2009	F007515
PIAGGIO	VESPA S 4T EU3	125	2007>2008	F007515
PIAGGIO	VESPA S 4T IE & COLLEGE	125	2009>2011	F007515
PIAGGIO	VESPA S 4T IE & COLLEGE	150	2009>2012	F007515
PIAGGIO	X-EVO	125	2007>2016	F007515
PIAGGIO	X-EVO	250	2007>2016	F007515
PIAGGIO	X-EVO	400	2007>2011	F007524
PIAGGIO	X10 4T-4V IE EU3	500	2012>2014	F007524
PIAGGIO	X7 EU3	125	2008>2008	F007515
PIAGGIO	X7 EU3	250	2008>2008	F007515
PIAGGIO	X7 EVO IE EU3	125	2009>2010	F007515
PIAGGIO	X7 EVO IE EU3	300	2009>2010	F007515
PIAGGIO	X8	125	2004>2004	F007515
PIAGGIO	X8	125	2005>2006	F007515
PIAGGIO	X8	200	2004>2004	F007515
PIAGGIO	X8	200	2005>2007	F007515
PIAGGIO	X8 EU3	250	2005>2008	F007515
PIAGGIO	X8 EU3	400	2006>2008	F007524
PIAGGIO	X8 PREMIUM EU2	125	2006>2006	F007515
PIAGGIO	X8 PREMIUM EU3	125	2006>2007	F007515
PIAGGIO	X8 STREET EU2	125	2006>2007	F007515
PIAGGIO	X8 STREET EU2	150	2006>2008	F007515
PIAGGIO	X9	125	2001>2002	F007515
PIAGGIO	X9	200	2002>2003	F007515
PIAGGIO	X9	500	2001>2002	F007524
PIAGGIO	X9 AMALFI	180	2000>2003	F007515
PIAGGIO	X9 EVOLUTION	125	2003>2003	F007515
PIAGGIO	X9 EVOLUTION	125	2005>2006	F007515
PIAGGIO	X9 EVOLUTION	200	2003>2003	F007515
PIAGGIO	X9 EVOLUTION	250	2004>2004	F007515
PIAGGIO	X9 EVOLUTION	250	2006>2006	F007515
PIAGGIO	X9 EVOLUTION	500	2003>2005	F007524

Marca	Modello	CC	Anno	Codice
PIAGGIO	X9 EVOLUTION	500	2006>2007	F007524
	X9 EVOLUTION ABS	500	2006>2007	F007524
	X9 EVOLUTION EU3	125	2007>2007	F007515
	ZIP	125	2000>2002	F007515
RENAULT	FULLTIME	125	2002>2003	F007515
RIEJU	MARATHON	125	2009>2009	F007523
	MARATHON PRO	125	2009>2009	F007523
	MARATHON PRO COMPETITION	125	2011>2011	F007523
SUZUKI	RS3	125	2011>2011	F007523
	AN BURGMAN K1/K2	250	2001>2002	F007510
	AN BURGMAN K3-K5	650	2003>2005	F007511
	AN BURGMAN K3/K6	250	2003>2006	F007510
	AN BURGMAN K3/K6	400	2003>2006	F007510
	AN BURGMAN K7/L0	400	2007>2010	F007522
	AN BURGMAN L1	400	2011>2011	F007522
	AN BURGMAN L2	400	2012>2012	F007522
	AN BURGMAN L3	400	2013>2013	F007522
	AN BURGMAN L4	400	2014>2014	F007522
	AN BURGMAN L5	400	2015>2015	F007522
	AN BURGMAN L6	400	2016>2016	F007522
	AN BURGMAN W/X/Y	250	1998>2000	F007510
	AN BURGMAN X/K2	400	1999>2002	F007510
	AN S-Y	125	1995>2000	F007522
	AN T-Y	150	1996>2000	F007522
	DL V-STROM L4	1000	2014>2014	F007515
	DL V-STROM L5	1000	2015>2015	F007515
	DL V-STROM L6	1000	2016>2017	F007515
	EPICURO	125	1999>2001	F007522
EPICURO	150	1999>2001	F007522	
LT-A KINGQUAD K6/K7	700	2006>2007	F007511	
LT-A KINGQUAD X L2	500	2012>2012	F007511	
LT-A KINGQUAD XP K9/L0	500	2009>2010	F007511	
LT-A KINGQUAD XP L1	500	2011>2011	F007511	
LT-A KINGQUAD XP L2	500	2012>2012	F007511	
LT-A X KINGQUAD K8/L0	750	2008>2010	F007511	
LT-A X KINGQUAD L1	750	2011>2011	F007511	
LT-A X KINGQUAD L2	750	2012>2012	F007511	
LT-A XP KINGQUAD K9/L0	750	2009>2010	F007511	
LT-A XP KINGQUAD L1	750	2011>2011	F007511	
LT-A XP KINGQUAD L2	750	2012>2012	F007511	

Marca	Modello	CC	Anno	Codice	
SUZUKI	LT-A400F KINGQUAD 4X4 K8/L0	400	2008>2010	F007511	
	LT-A400F KINGQUAD 4X4 L1	400	2011>2011	F007511	
	LT-A450F KINGQUAD 4X4 K7/L0	450	2007>2010	F007511	
	LT-A500F VINSON K4/K7	500	2004>2007	F007511	
	LT-Z QUADSPORT K7/L0	90	2007>2010	F007522	
	UE CT K1	125	2001>2001	F007522	
	UE CT K1	150	2001>2001	F007522	
	UH BURGMAN K2/K6	125	2002>2006	F007522	
	UH BURGMAN K2/K6	150	2002>2006	F007522	
	UH BURGMAN K7/L0	125	2007>2010	F007522	
	UH BURGMAN K7/L0	200	2007>2010	F007522	
	UH BURGMAN L1	125	2011>2011	F007522	
	UH BURGMAN L1	200	2011>2012	F007522	
	UX SIXTEEN K8/L0	125	2008>2010	F007522	
	UX SIXTEEN K8/L0	150	2008>2010	F007522	
	UX SIXTEEN L1	125	2011>2011	F007522	
UX SIXTEEN L1	150	2011>2011	F007522		
VENT	BAJA	125	2018>2019	F007523	
	BAJA RR	125	2018>2019	F007523	
	DERAPAGE	125	2018>2019	F007523	
	DERAPAGE RR	125	2018>2019	F007523	
	TRAIL	125	2018>2019	F007523	
	YAMAHA	MAJESTY	400	2004>2005	F007521
		MAJESTY	400	2006>2006	F007521
MAJESTY		400	2007>2008	F007521	
MAJESTY		400	2009>2011	F007521	
MAJESTY ABS		400	2007>2007	F007521	
MAJESTY ABS		400	2008>2008	F007521	
MAJESTY ABS		400	2009>2011	F007521	
MT		125	2015>2015	F007523	
MT		125	2016>2016	F007523	
MT A		125	2015>2015	F007523	
MT A		125	2016>2016	F007523	
MT A		125	2017>2017	F007523	
MT A		125	2018>2018	F007523	
MT A		125	2019>2019	F007523	
MT A	125	2020>2020	F007523		
T-MAX 4B5	500	2009>2011	F007517		
T-MAX 4B5 ABS	500	2008>2011	F007517		
T-MAX 59C	530	2012>2012	F007517		

Marca	Modello	CC	Anno	Codice
YAMAHA	T-MAX 59C	530	2013>2014	F007517
	T-MAX 59C	530	2015>2016	F007517
	T-MAX 59C ABS	530	2012>2012	F007517
	T-MAX 59C ABS	530	2013>2014	F007517
	T-MAX 59C ABS	530	2015>2016	F007517
	T-MAX 59C SP	530	2015>2015	F007517
	T-MAX 59C SP ABS	530	2015>2016	F007517
	T-MAX 5GJ	500	2001>2003	F007517
	T-MAX 5VU	500	2004>2005	F007517
	T-MAX 5VU	500	2006>2006	F007517
	T-MAX 5VU	500	2007>2007	F007517
	T-MAX 5VU	500	2008>2008	F007517
	T-MAX 5VU ABS	500	2005>2005	F007517
	T-MAX 5VU ABS	500	2006>2006	F007517
	T-MAX 5VU ABS	500	2007>2007	F007517
	T-MAX 5VU BLACK MAX	500	2006>2006	F007517
	T-MAX 5VU BLACK MAX - NIGHT MAX	500	2007>2007	F007517
	WR-R IE	125	2009>2011	F007523
	WR-X IE	125	2009>2011	F007523
	WR-X IE	125	2013>2014	F007523
	X-CITY	125	2008>2011	F007523
	X-MAX	300	2017>2017	F007523
	X-MAX	300	2018>2018	F007523
	X-MAX	400	2013>2014	F007521
	X-MAX	400	2015>2016	F007521
	X-MAX ABS	300	2019>2019	F007523
	X-MAX ABS	300	2020>2020	F007523
	X-MAX ABS	400	2014>2014	F007521
	X-MAX ABS	400	2015>2017	F007521
	X-MAX ABS IRON MAX	300	2019>2019	F007523
	X-MAX ABS IRON MAX	400	2019>2019	F007521
	X-MAX ABS TECH MAX	300	2020>2020	F007523
	X-MAX IRONMAX ABS	400	2016>2016	F007521
	X-MAX MOMODESIGN	400	2014>2014	F007521
	X-MAX MOMODESIGN ABS	400	2014>2014	F007521
	X-MAX R	125	2006>2007	F007523
	X-MAX R	125	2008>2009	F007523
	X-MAX R	125	2010>2012	F007523
	X-MAX R	125	2012>2013	F007523
	X-MAX R	125	2014>2014	F007523

Marca	Modello	CC	Anno	Codice
YAMAHA	X-MAX R	125	2015>2016	F007523
	X-MAX R ABS	125	2011>2011	F007523
	X-MAX RA	400	2018>2018	F007521
	X-MAX RA	400	2019>2019	F007521
	X-MAX RA ABS	125	2013>2013	F007523
	X-MAX RA ABS	125	2014>2015	F007523
	X-MAX RA ABS	125	2016>2016	F007523
	X-MAX RA ABS	125	2017>2017	F007523
	X-MAX RA ABS	125	2018>2018	F007523
	X-MAX RA ABS	125	2019>2019	F007523
	X-MAX RA ABS	125	2020>2020	F007523
	X-MAX RA ABS	400	2020>2020	F007521
	X-MAX RA ABS IRON MAX	125	2019>2019	F007523
	X-MAX RA ABS TECH MAX	125	2020>2020	F007523
	XT-R	660	2004>2005	F007519
	YZF R6	600	2001>2002	F007520
	YZF R6	600	2007>2007	F007520
	YZF R6	600	2008>2008	F007520
	YZF R6	600	2009>2009	F007520
	YZF R6	600	2010>2012	F007520
	YZF R6	600	2013>2015	F007520
	YZF R6 & LIMITED EDITION 07	600	2006>2006	F007520
	YZF R6 50TH	600	2012>2012	F007520
	YZF-R A IE	125	2015>2015	F007523
	YZF-R A IE	125	2016>2016	F007523
	YZF-R A IE	125	2017>2017	F007523
	YZF-R A IE	125	2018>2018	F007523
	YZF-R A IE	125	2019>2019	F007523
	YZF-R A IE	125	2020>2020	F007523
	YZF-R A IE MONSTER ENERGY	125	2020>2020	F007523
	YZF-R IE	125	2008>2011	F007523
	YZF-R IE	125	2012>2012	F007523
	YZF-R IE	125	2013>2013	F007523
	YZF-R IE	125	2014>2014	F007523
	YZF-R IE	125	2015>2015	F007523
	YZF-R IE	125	2016>2016	F007523



- ◀ cod. **FZ00363**
Frizione tipo originale per motore scooter 50 cc Morini/Suzuki ad aria



- ◀ cod. **FZ00364**
Frizione tipo originale per motore scooter 50 cc Piaggio/Honda

RIFERIMENTO ORIGINALE

Piaggio	CM1002045
---------	-----------



- ◀ cod. **FZ00365**
Frizione per motori scooter 50 cc Minarelli/Yamaha 3 ceppi con campana Ø interno 107 mm



- ◀ cod. **FZ00366**
Frizione completa per motori scooter 50 cc Minarelli/Yamaha 2 ceppi con campana Ø interno 105 mm



- ◀ cod. **FZ00371**
Frizione tipo originale per motore scooter Minarelli/Yamaha 125 cc

RIFERIMENTO ORIGINALE

Yamaha	5DSE66200000
Mbk	5DSE66200000

Malaguti	73503300
----------	----------

APPLICABILITÀ

ITALJET	JUPITER 125 4T 01-02, MILLENIUM 125 4T 00-02
MALAGUTI	MADISON 125 4T 99-01, MADISON R RESTYLING 125 4T 02-02, MADISON R RESTYLING EU2 125 4T 03-04, PHANTOM MAX 125 4T 03-03
MBK	DOODO 125 4T 00-00, SKYLINER 125 4T 98-02, SKYLINER E 125 4T 03-03, THUNDER 125 4T 01-02

YAMAHA	CYGNUS X (NXC) 125 4T 04-06, CYGNUS X IE EU3 (NXC) 125 4T 07-11, MAJESTY 125 4T 98-00, MAJESTY (SNR1) 125 4T 01-01, MAJESTY (SNR8) 125 4T 02-02, MAJESTY E 125 4T 03-09, MAXSTER 125 4T 01-02, TEO'S 125 4T 00-00
---------------	---



◀ cod. **FZ00378**

Frizione tipo originale per motore scooter 125/150/180 4T Piaggio

RIFERIMENTO ORIGINALE

Piaggio	CM161202
Aprilia	CM161202
Gilera	CM161202

Derbi	CM161202
Malaguti	43500800

APPLICABILITÀ

APRILIA ATLANTIC ARRECIFE 125 4T 03-05, ATLANTIC 200 4T 03-05, ATLANTIC ARRECIFE 200 4T 03-05, SPORT CITY 200 4T 04-06

GILERA RUNNER VX 125 4T 00-06, RUNNER 180 4T 00-01, RUNNER VXR 180 4T 00-01

MALAGUTI MADISON 3 125 4T 06-09, MADISON S RESTYLING 200 4T 02-02, PHANTOM MAX 200 4T 03-03

PIAGGIO FLY 125 4T 05-07, FLY 150 4T 05-07, LIBERTY 150 4T 01-02, SKYPPER 4T 150 4T 00-02, VESPA ET4 150 4T 99-02, HEXAGON GTX 180 4T 00-00, SUPER HEXAGON GTX 12 180 4T 01-02, X9 AMALFI 180 4T 00-03, CARNABY 200 4T 07-08, LIBERTY 200 4T 06-06, VESPA GRANTURISMO 200 4T 03-05, VESPA GTS EU3 200 4T 07-12, VESPA GTV EU3 200 4T 06-08, X8 200 4T 04-04

RENAULT FULLTIME 125 4T 02-03



◀ cod. **FZ00382**

Frizione completa per motore scooter Piaggio Beverly 250 cc 4T

RIFERIMENTO ORIGINALE

Piaggio	8722515
Aprilia	8722515
Gilera	8722515

Derbi	8722515
Malaguti	43500700

APPLICABILITÀ

APRILIA ATLANTIC ARRECIFE 250 4T 03-05, ATLANTIC EU3 250 4T 06-08, SCARABEO 250 4T 04-06, SPORT CITY EU3 250 4T 06-08

DERBI GP1 250 4T 06-07

GILERA NEXUS EU3 250 4T 06-07

MALAGUTI MADISON 3 250 4T 06-09, MADISON RS 250 4T 04-04, PHANTOM MAX 250 4T 04-04

PIAGGIO BEVERLY 250 4T 05-07, CARNABY 250 4T 08-09, MP3 250 4T 06-08, MP3 LT 250 4T 08-09, MP3 MIC 250 4T 08-09, VESPA GT 60 EU3 250 4T 06-07, VESPA GTS 250 4T 05-16, VESPA GTS ABS 250 4T 05-12, VESPA GTV 250 4T 06-09, X-EVO 250 4T 07-16, X8 EU3 250 4T 05-08, MP3 4T 4V IE LT IBRIDO 300 4T 10-11, MP3 IE LT 300 4T 10-11, MP3 IE LT TOURING 300 4T 11-13, MP3 IE LT/SPORT 300 4T 11-14, MP3 IE MIC 300 4T 10-11, MP3 IE TOURING 300 4T 11-12, MP3 YOURBAN ERL 300 4T 11-15, MP3 YOURBAN LT ERL 300 4T 11-12



◀ cod. **FZ00383**

Frizione completa per motore scooter Piaggio Beverly 500 cc 4T

RIFERIMENTO ORIGINALE

Piaggio	8405775
Aprilia	8405775

Gilera	8405775
Malaguti	43500500

APPLICABILITÀ

APRILIA ATLANTIC 500 4T 01-04, SCARABEO 500 4T 03-06

GILERA NEXUS 500 4T 03-05

MALAGUTI SPIDER MAX GT 500 4T 04-05, SPIDER MAX GT EU3 500 4T 06-06, SPIDER MAX RS 500 4T 08-08

PEUGEOT GEOPOLIS IE EU3 400 4T-4V 90-02, SATELIS EU3 400 4T 07-12, GEOPOLIS IE EU3 500 4T-4V 90-02, SATELIS EU3 500 4T 90-02

PIAGGIO BEVERLY 500 4T 02-06, BEVERLY CRUISER 500 4T 07-12, BEVERLY IE EU3 500 4T 06-08, X9 500 4T 01-02, X9 EVOLUTION 500 4T 03-07



◀ cod. **FZ00385**

Frizione completa per motore scooter 50 cc Piaggio Pure Jet

RIFERIMENTO ORIGINALE

Piaggio	CM1002045
---------	-----------



◀ **cod. FZ00386**
Frizione completa per Honda SH 125/150 cc

RIFERIMENTO ORIGINALE

Honda	22300KGF912
Honda	22300KGG911

Malaguti	65044700
Keeway	200203160000

APPLICABILITÀ

HONDA @ [NES] 125 4T 00-06, DYLAN [SES] 125 4T 02-04, PS I [PES] 125 4T 06-10, SH 125 4T-2V 01-04, SH IE SCOOPY 125 4T-2V 05-12, SILVER WING [FES] 125 4T-2V 07-12, @ [NES] 150 4T 00-06, DYLAN [SES] 150 4T 02-04, PANTHEON IE [FES] 150 4T-2V 03-05, PS I [PES] 150 4T 06-10, SH 150 4T-2V 01-04, SH IE SCOOPY 150 4T 05-12, SILVER WING [FES] 150 4T-2V 07-12

KEEWAY OUTLOOK 125 4T 07-08, OUTLOOK 150 4T 07-08

KYMCO AGILITY 125 4T 06-06, AGILITY EU3 125 4T 06-08, AGILITY PLUS 125 4T 14-14, AGILITY R16 125 4T 08-09, AGILITY R16 125 4T 12-12, AGILITY RS 125 4T 09-09, HEROISM 125 4T 95-97, K-XCT I 125 4T 12-14, LIKE 125 4T 09-09, MOVIE 125 4T 99-00, MOVIE EU3 125 4T 03-04, MOVIE XL 125 4T 01-01, MOVIE XL EU2 125 4T 06-07, MOVIE XL 125 4T 01-01, MOVIE XL EU2 125 4T 03-04, PEOPLE 125 4T 99-00, PEOPLE EU2 125 4T 03-03, PEOPLE EU3 125 4T 07-08, PEOPLE EU3 125 4T 11-11, PEOPLE ONE I 125 4T 13-13, PEOPLE S 125 4T 05-05, PEOPLE S DD EU3 125 4T 07-08, SUPER 8 125 4T 08-09, VIVIO 125 4T 00-00, AGILITY R16 150 4T 08-09, HEROISM 150 4T 95-97, MOVIE EU3 150 4T 06-07, MOVIE XL 150 4T 01-01, MOVIE XL EU2 150 4T 03-04, PEOPLE 150 4T 99-00, PEOPLE EU2 150 4T 03-03, VIVIO 150 4T 00-00, AGILITY I PLUS 200 4T 14-14, AGILITY R16 200 4T 12-12, AGILITY R16 200 4T 10-10, LIKE IE 200 4T 09-09, LIKE LX 200 4T 12-12, PEOPLE S 200 4T 05-05, PEOPLE S I 200 4T 07-07

MALAGUTI BLOG IE 125 4T 09-10, CENTRO IE EU3 125 4T 08-09, CENTRO SL IE EU3 125 4T 09-10, CIAK MASTER 125 4T 04-04, CIAK MASTER 150 4T 04-04, BLOG IE 160 4T 09-10, CENTRO IE EU3 160 4T 08-09, CENTRO SL IE EU3 160 4T 09-10, CIAK MASTER EURO 2 200 4T 06-06

WT MOTORS ATENE 150 4T 08-10



◀ **cod. FZ00388**
Frizione completa Yamaha Majesty 250 cc STD type

RIFERIMENTO ORIGINALE

Yamaha	5GM166200100
Mbk	5GM166200100
Aprilia	AP8122452

Malaguti	73504300
Sym	22300HMB300

APPLICABILITÀ

APRILIA LEONARDO 250 4T 02-04, LEONARDO 300 4T 02-04

ITALJET JUPITER 250 4T 00-00

MALAGUTI MADISON S 250 4T 99-01, PASSWORD 250 4T 05-06, PASSWORD EU3 250 4T 07-08

MBK SKYLINER 250 4T 00-03, SKYLINER ABS 250 4T 03-03, KILIBRE 300 4T 03-06

SYM GTS 250 4T-4V 07-08, JOYMAX 250 4T-4V 05-07, CITYCOM 300 4T-4V 08-09, JOYMAX EVO 300 4T-4V 09-09

TGB X MOTION 250 4T-4V 08-09

YAMAHA MAJESTY 250 4T 00-03, MAJESTY ABS 250 4T 03-03, X-CITY 250 4T 07-15, X-MAX 250 4T 05-16, X-MAX ABS 250 4T 14-15, VERSITY 300 4T 03-06



◀ **cod. FZ00390**
Frizione completa Honda Foresight 250 cc

RIFERIMENTO ORIGINALE

Honda	22535KFG000
-------	-------------

APPLICABILITÀ

HONDA FORESIGHT [FES] 250 4T 98-99, FORESIGHT [FES] D.D. 250 4T 00-05

PIAGGIO X9 250 4T 00-01



◀ **cod. FZ00392**
Frizione completa Honda SH 300 cc

RIFERIMENTO ORIGINALE

Honda	22300KTW902
-------	-------------

APPLICABILITÀ

HONDA SH IE SCOOPY 300 4T-4V 07-19



◀ **cod. FZ00394**
Frizione completa 5 ceppi Yamaha Majesty 400 cc

RIFERIMENTO ORIGINALE

Yamaha	5RU166202000
--------	--------------

APPLICABILITÀ

YAMAHA MAJESTY 400 4T 04-11, MAJESTY ABS 400 4T 07-11, X-MAX 400 4T-4V 13-16, X-MAX ABS 400 4T-4V 14-17, X-MAX IRONMAX ABS 400 4T-4V 16-16, X-MAX MOMODESIGN 400 4T-4V 14-14, X-MAX MOMODESIGN ABS 400 4T-4V 14-14, X-MAX RA 400 4T-4V 18-18



◀ **cod. FZ00396**
Frizione completa Piaggio Beverly 125 cc

RIFERIMENTO ORIGINALE

Piaggio	CM161202
---------	----------

APPLICABILITÀ

APRILIA ATLANTIC 125 4T 03-05, ATLANTIC EU3 125 4T 06-08, ATLANTIC EU3 125 4T 10-12, MOJITO 125 4T 03-08, SCARABEO 125 4T 03-06, SCARABEO EU3 125 4T 06-07, SPORT CITY 125 4T 04-06, SPORT CITY CUBE 125 4T 08-10, SPORT CITY EU3 125 4T 06-08

DERBI BOULEVARD 125 4T 02-04, BOULEVARD EU2 125 4T 04-07, GP1 EU 2 125 4T 06-06, GP1 LOW SEAT EU3 125 4T 07-08, RAMBLA 125 4T 08-09, BOULEVARD 150 4T 02-04, BOULEVARD EU3 150 4T 04-07

GILERA DNA 125 4T 01-01, NEXUS EU3 125 4T 07-08, NEXUS IE EU3 125 4T 08-10

PIAGGIO BEVERLY 125 4T 01-03, BEVERLY EU3 125 4T 07-08, BEVERLY RST 125 4T 04-07, BEVERLY TOURER EU3 125 4T 07-10, CARNABY 125 4T 07-10, HEXAGON GTX 125 4T 00-00, LIBERTY 125 4T 98-02, MP3 125 4T 06-08, MP3 IBRIDO 125 4T 09-10, MP3 IE 125 4T 08-09, SKYPPER 4T 125 4T 00-02, SUPER HEXAGON GTX 12 125 4T 01-02, VESPA ET4 125 4T 99-02, VESPA GRANTURISMO 125 4T 03-07, VESPA GRANTURISMO EU3 125 4T 06-07, VESPA GTS 4T IE SUPER 125 4T 09-16, VESPA GTS EU3 125 4T 07-12, VESPA GTV 125 4T 06-08, VESPA GTV 4T NAVY EU3 125 4T 08-08, X-EVO 125 4T 07-16, X7 EU3 125 4T 08-08, X7 EVO IE EU3 125 4T 09-10, X8 125 4T 04-06, X9 125 4T 01-02, ZIP 125 4T 00-02



◀ **cod. FZ00400**
Frizione Kymco Xciting 300 cc

RIFERIMENTO ORIGINALE

Kymco	00127965
-------	----------

APPLICABILITÀ

KYMCO B&W 250 4T 00-00, B&W EU2 250 4T 03-03, GRAND DINK 250 4T 01-02, GRAND DINK EU2 250 4T 03-04, PEOPLE LC 250 4T 03-04, PEOPLE S 250 4T 06-06, PEOPLE S 1 250 4T 07-07, X CITING 250 4T 05-05, X CITING 1 250 4T 06-07, YUP 250 4T 03-03, PEOPLE S 1 300 4T 08-08, X CITING 1 300 4T 08-08, X CITING 1 R 300 4T 08-09

◀ **cod. FZ00401**
Frizione Yamaha X-Max 125 cc

RIFERIMENTO ORIGINALE

Yamaha	1B9E66200200
Yamaha	5CG166200100
Yamaha	5KDE66200000

Mbk	5KDE66200000
Mbk	5CG166200100
Malaguti	73503600

APPLICABILITÀ

APRILIA LEONARDO 250 4T 99-01, LEONARDO ST 250 4T 01-01

ITALJET JUPITER 150 4T 01-02, MILLENNIUM 150 4T 00-02, JUPITER 250 4T 01-02

MALAGUTI MADISON T 150 4T 99-01

MBK SKYCRUISER 125 4T-4V 07-07, DOODO 150 4T 01-02, SKYLINER 150 4T 00-02, THUNDER 150 4T 01-02, SKYLINER E 180 4T 03-03

YAMAHA X-CITY EU3 125 4T-4V 08-11, X-MAX R 125 4T-4V 06-16, X-MAX R ABS 125 4T-4V 11-11, X-MAX RA ABS 125 4T-4V 13-16, MAJESTY 150 4T 00-00, MAJESTY (SNS1) 150 4T 01-01, MAJESTY (SNS6) 150 4T 02-02, MAXSTER 150 4T 01-02, TEO'S 150 4T 01-02, MAJESTY E 180 4T 03-06, MAJESTY 250 4T 96-98, MAJESTY DX 250 4T 98-99



◀ cod. **FZ00403**
Frizione Suzuki Burgman 400 cc X-K2 / K3-K6

RIFERIMENTO ORIGINALE

Suzuki	21501-15F01-000
--------	-----------------

APPLICABILITÀ

SUZUKI AN BURGMAN K3/K6 400 4T 03-06, AN BURGMAN X/K2 400 4T 99-02



◀ cod. **FZ00405**
Frizione Honda Vision 110 cc

APPLICABILITÀ

HONDA VISION [NSC] 110 4T-2V 12-12, SH I ABS 125 4T-2V 13-17, SH I ABS 150 4T-2V 13-17



◀ cod. **FZ00407**
Frizione Honda PCX 125 cc

APPLICABILITÀ

HONDA PCX 125 4T-2V 10-11, PCX 125 4T-2V 13-13, PCX 150 4T-2V 13-17



◀ cod. **FZ00409**
Frizione Kymco DOWNTOWN 200/300 cc

RIFERIMENTO ORIGINALE

Kymco	122241
Kymco	22300-LGE5-E00

APPLICABILITÀ

KYMCO DOWNTOWN I 200 4T 10-10, PEOPLE GTI 200 4T 10-10, DOWNTOWN ABS 300 4T 10-10, DOWNTOWN I 300 4T 09-09, DOWNTOWN I 300 4T 11-11, DOWNTOWN I ABS 300 4T 11-16, PEOPLE GTI 300 4T 10-11



◀ cod. **FZ00411**
Frizione completa Ø 130 Kymco DOWNTOWN 125 cc

RIFERIMENTO ORIGINALE

Kymco	122170
-------	--------

APPLICABILITÀ

KYMCO DOWNTOWN I 125 4T 09-16



◀ cod. **FZ00413**
Frizione Suzuki Burgman 125 cc K7-L3

APPLICABILITÀ

SUZUKI UH BURGMAN K7/LO 125 4T 07-10, UH BURGMAN L1 125 4T 11-11, UH BURGMAN L3 125 4T 13-13, UX SIXTEEN K8/LO 125 4T 08-10, UX SIXTEEN L1 125 4T 11-11

RIFERIMENTO ORIGINALE

Suzuki	21501-46G10-000
--------	-----------------



◀ cod. **FZ00414**
Frizione Suzuki Burgman 200 cc k7-L4

APPLICABILITÀ

SUZUKI UH BURGMAN K7/LO 200 4T 07-10, UH BURGMAN L1 200 4T 11-12

RIFERIMENTO ORIGINALE

Suzuki	21501-03H30-000
--------	-----------------



◀ cod. **FZ00417**
Frizione Sym Symphony 125/150 cc

RIFERIMENTO ORIGINALE

Sym	22300F6A000
-----	-------------

APPLICABILITÀ

SYM FIDDLE II 125 4T 10-10, JET 4 125 4T 09-10, SYMPHONY 125 4T 09-09, SYMPHONY S 125 4T 09-10, SYMPHONY SR 125 4T 10-10, FIDDLE II 150 4T 10-10, SYMPHONY 150 4T 09-09, SYMPHONY S 150 4T 10-10, SYMPHONY SR 150 4T 10-10



◀ cod. **FZ00418**
Frizione Piaggio Liberty 125 cc EU3

RIFERIMENTO ORIGINALE

Piaggio	CM1612015
---------	-----------

APPLICABILITÀ

APRILIA SPORT CITY ONE 4T EU3 125 4T 08-11, SR MOTARD 125 4T-2V 12-14

DERBI BOULEVARD 4T EU3 125 4T 08-12, SONAR 4T 125 4T 09-11, VARIANT SPORT 4T EU3 125 4T 12-12, BOULEVARD 4T E3 150 4T 10-10, SONAR 4T 150 4T 09-09

PIAGGIO FLY EU3 125 4T 07-07, LIBERTY 4T EU3 125 4T 06-08, TYPHOON 4T 2V E3 125 4T 10-11, VESPA LX 4T EU3 TOURING 125 4T 10-11, VESPA LXV IE 4T 125 4T 10-13, VESPA S 4T EU3 125 4T 07-08, VESPA S 4T IE & COLLEGE 125 4T 09-11, X8 STREET EU2 125 4T 06-07, FLY EU3 150 4T 08-11, LIBERTY MOC 4T 150 4T 09-13, VESPA LX EU3 IE 150 4T 09-11, VESPA LX TOURING 150 4T 10-12, VESPA S 4T 150 4T 08-09, X8 STREET EU2 150 4T 06-08



◀ cod. **FZ00419**
Frizione Suzuki Burgman 400 cc K7-L3

APPLICABILITÀ

SUZUKI AN BURGMAN K7/LO 400 4T 07-10, AN BURGMAN L1 400 4T 11-11, AN BURGMAN L2 400 4T 12-12, AN BURGMAN L3 400 4T 13-13, AN BURGMAN L4 400 4T 14-14, AN BURGMAN L5 400 4T 15-15, AN BURGMAN L6 400 4T 16-16



◀ cod. **FZ00422**
Frizione piaggio liberty 125 cc 3V Iget

APPLICABILITÀ

PIAGGIO LIBERTY 4T 3V IE E3 125 4T-3V 13-13



◀ cod. **FZ00423**
Frizione piaggio vespa lx primavera 125 cc 3V Iget

APPLICABILITÀ

PIAGGIO LIBERTY 4T 3V IE E3 125 4T-3V 13-14, VESPA LX PRIMAVERA 4T 3V IE 125 4T-3V 13-17, VESPA SPRINT 4T 3V IE 125 4T-3V 14-15



◀ cod. **FZ00424**
Frizione piaggio vespa sprint 125 cc 3V Abs

APPLICABILITÀ

PIAGGIO LIBERTY IGET 4T 3V IE 125 4T-3V 15-17, VESPA PRIMAVERA 4T 3V E4 IGET ABS 125 4T-3V 16-17, VESPA SPRINT IGET 4T 3V ABS (EMEA) 125 4T-3V 16-17

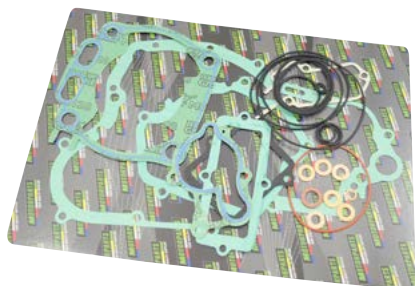

NOVITÀ

◀ **cod. APRTP0127**
Serie guarnizioni smeriglio

APPLICABILITÀ

APRILIA CLASSIC 125 2T 95-01, MX 125 2T 04-06, RX 125 2T 95-01

◀ **cod. DERTP0004**
Serie guarnizioni smeriglio

APPLICABILITÀ

APRILIA RS 50 2T 06-10, RS4 50 2T 11-13, RS4 REPLICA 50 2T 14-16, RX 50 2T 06-10, RX 50 2T 14-16, SX 50 2T 06-10, SX 50 2T 14-16, SX LIMITED EDITION 50 2T 14-16

DERBI GPR 2T 50 2T 13-13, GPR 2T EU2 50 2T 09-10, GPR NUDE & GPR NUDE TUNING 50 2T 06-08, GPR NUDE SPORT 50 2T 06-06, GPR R EU2 - GPR REPLICA EU2 50 2T 08-08, GPR RACING EU2 50 2T 06-06, GPR REPLICA & GPR R EU2 50 2T 06-06, GPR REPLICA 2T MALOSSI 50 2T 07-07, GPR REPLICA PESEK EU2 50 2T 07-07, SENDA HYP DRD EVO EU2 50 2T 08-09, SENDA HYP DRD EVO LIMITED EDITION EU2 50 2T 08-08, SENDA R DRD PRO EU2 50 2T 05-11, SENDA R DRD RACING EU2 50 2T 05-08, SENDA R DRD X-TREME 2T EU2 50 2T 14-15, SENDA R DRD X-TREME 2T EURO2 50 2T 10-12, SENDA R X-RACE 2T EU2 50 2T 10-10, SENDA R X-RACE EU2 50 2T 06-09, SENDA R X-TREME 2T EU2 50 2T 10-10, SENDA R X-TREME EU2 50 2T 05-08, SENDA SM DRD PRO EU2 50 2T 05-11, SENDA SM DRD PRO EU2 2VER 50 2T 05-08, SENDA SM DRD RACING EU2 50 2T 05-08, SENDA SM DRD RACING EU2 50 2T 10-13, SENDA SM DRD RACING LTD EU2 50 2T 07-07, SENDA SM DRD X-TREME 2T EU2 50 2T 14-15, SENDA SM DRD X-TREME 2T EU2 LIMITED ED 50 2T 14-15, SENDA SM X-RACE 2T EU2 50 2T 10-10, SENDA SM X-RACE EU2 50 2T 06-09, SENDA SM X-RACE EU2 2VER 50 2T 07-09, SENDA SM X-TREME 2T EU2 50 2T 10-10, SENDA SM X-TREME EU2 50 2T 05-08

GILERA RCR 50 2T 06-07, RCR 50 2T 11-12, RCR (CHE-SYC) 50 2T 13-15, SMT 50 2T 06-17, SMT RACING 50 2T 11-12

VALENTI RACING RME 50 2T 15-17, SM 50 2T 15-17

◀ **cod. GASTP0002**
Serie guarnizioni smeriglio

APPLICABILITÀ

GAS GAS EC 2T 200 2T 97-13, MX 200 2T 97-13, EC 2T 250 2T 97-13, ENDURO 250 2T 97-03, MX 250 2T 97-13, EC 2T 300 2T 97-13, ENDURO 300 2T 97-03, MX 300 2T 97-13

◀ **cod. HONTP0126**
Serie guarnizioni smeriglio

APPLICABILITÀ

HONDA NS-FG-FH-RK-RL 125 2T 85-93, NSR-FM-FN 125 2T 88-03, NSR-RK-RL-RM-RN-RP-RR 125 2T 89-89

◀ **cod. HUSTP0128**
Serie guarnizioni smeriglio

APPLICABILITÀ

HUSQVARNA CR (HUSQVARNA ENGINE) 125 2T 97-14, SM /S (HUSQVARNA ENGINE) 125 2T 98-14, WR (HUSQVARNA ENGINE) 125 2T 97-14, WRE 125 2T 98-12

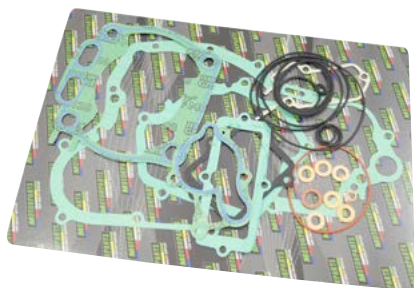

◀ cod. **KTMTPO004**
Serie guarnizioni smeriglio

APPLICABILITÀ

HUSQVARNA TC (KTM ENGINE) 85 2T 14-17

KTM MX 85 2T 03-09, SX 85 2T 03-17, XC 85 2T 03-13

◀ cod. **KTMTPO129**
Serie guarnizioni smeriglio

APPLICABILITÀ

KTM EXC-EGS 125 2T 02-05, SX 125 2T 02-15, TC 125 2T 14-15

◀ cod. **KTMTPO134**
Serie guarnizioni smeriglio

APPLICABILITÀ

HUSABERG TE 250 2T 11-12, TE 300 2T 11-12

HUSQVARNA TC (KTM ENGINE) 250 2T 14-16, TE (KTM ENGINE) 250 2T 14-16, TE (KTM ENGINE) 300 2T 14-16

KTM EXC 250 2T 05-16, EXC SIX DAYS 250 2T 13-16, FREERIDE R 250 2T 14-17, SX 250 2T 07-16, XC 250 2T 06-16, XC-W 250 2T 08-15, XC-WE 250 2T 08-08, EXC 300 2T 08-16, EXC SIX DAYS 300 2T 13-15, XC 300 2T 06-16, XC-W

◀ cod. **KTMTPO138**
Serie guarnizioni smeriglio

APPLICABILITÀ

HUSQVARNA TC (KTM ENGINE) 65 2T 17-20

KTM SX 65 2T 09-20, XC 65 2T 09-10

◀ cod. **KTMTPO669**
Serie guarnizioni smeriglio

APPLICABILITÀ

HUSQVARNA TC (KTM ENGINE) 125 2T 16-20, TX (KTM ENGINE) 125 2T 17-19, TE (KTM ENGINE) 150 2T 17-19

KTM SX 125 2T 16-20, XC-W 125 2T 17-19, EXC 150 2T 20-20, SX 150 2T 16-20, XC-W 150 2T 17-19

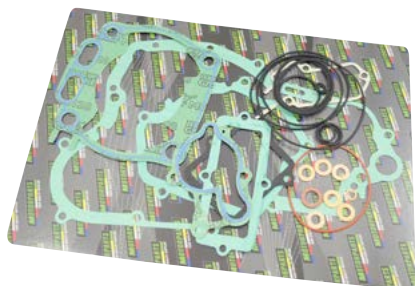

NOVITÀ

◀ **cod. MINTP0022**
Serie guarnizioni smeriglio

APPLICABILITÀ

APRILIA CLASSIC 50 2T 91-02, EUROPA 50 2T 91-02, PEGASO 50 2T 91-02, RED ROSE 50 2T 91-02, RS 50 2T 91-02
MALAGUTI FIFTY EVOLUTION 50 2T 90-94
MINARELLI AM 3-4-5-6 50 2T 91-12
MOTOR HISPANIA FURIA 50 2T 91-02
YAMAHA DT R 50 2T 03-10, DT X 50 2T 03-10, TZR 50 2T 03-10

◀ **cod. YAMTP0004**
Serie guarnizioni smeriglio

APPLICABILITÀ

APRILIA AMICO 50 2T 94-94, AMICO 50 2T 96-98, AMICO GL/GLE 50 2T 93-95, AMICO LX/SPORT/CAT 50 2T 92-93, SR (VERTICALE) 50 2T 93-93
MBK BOOSTER 50 2T 90-04, BOOSTER 50 2T 90-94, BOOSTER EURO 2 50 2T 04-04, BOOSTER NG 50 2T 95-03, BOOSTER ROCKET 50 2T 97-98, BOOSTER SPIRIT 50 2T 96-00, BOOSTER SPIRIT 50 2T 03-03, BOOSTER SPIRIT EURO2 50 2T 03-03, BOOSTER TRACK 50 2T 96-98, STUNT 50 2T 00-02
YAMAHA BW'S 50 2T 97-16, BW'S BUMP 50 2T 97-98, BW'S EASY 50 2T 13-13, BW'S NAKED 50 2T 03-04, BW'S NAKED 50 2T 09-16, BW'S NEXT GENERATION 50 2T 97-06, BW'S ORIGINAL 50 2T 99-02, BW'S ORIGINAL EURO 2 50 2T 03-03, RS SPY 50 2T 95-98, SLIDER 50 2T 00-02, ZUMA 50 2T 97-01

◀ **cod. YAMTP0017**
Serie guarnizioni smeriglio

APPLICABILITÀ

APRILIA AREA 51 50 2T 98-00, GULLIVER LC 50 2T 96-98, RALLY LIQUID COOLED 50 2T 96-99, SR LIQUID COOLED 50 2T 94-96, SR RACING 50 2T 97-99, SR STEALTH 50 2T 97-00
BENELLI 491 RACING 50 2T 98-99, 491 RR 50 2T 99-01, 491 SP 50 2T 99-99, 491 SPORT 50 2T 98-99, K2 LIQUID COOLED 50 2T 98-01
BETA ARK LC 50 2T 96-08, EIKON 50 2T 99-03
ITALJET DRAGSTER 50 2T 98-02
MALAGUTI F12 PHANTOM EURO 2 50 2T 02-02, F12 PHANTOM LC 50 2T 94-98, F12 PHANTOM LC EURO 2,3 50 2T 03-04, F12 R PHANTOM LC 50 2T 07-10, F12 RESTYLING EURO 1 50 2T 99-02, F12 RESTYLING LC EURO 2 50 2T 06-06, F15 FIRE FOX 50 2T 96-98, F15 FIRE FOX EURO 2 50 2T 02-06, F15 FIRE FOX EURO 2,3 50 2T 03-04
MBK MACH G LC 50 2T 02-04, NITRO 50 2T 97-04, NITRO EURO 2 50 2T 03-03
YAMAHA AEROX 50 2T 97-02, AEROX 50 2T 04-16, AEROX EURO 2 50 2T 03-03, AEROX NAKED 50 2T 13-16, AEROX R 50 2T 99-00, JOG R LC 50 2T 02-15

◀ **cod. YAMTP0087**
Serie guarnizioni smeriglio

APPLICABILITÀ

YAMAHA YZ LC-LW 80 2T 94-97, YZ N-LW 80 2T 01-01, YZ 85 2T 01-17, YZ-LW 85 2T 18-18

◀ **cod. YAMTP0111**
Serie guarnizioni smeriglio

APPLICABILITÀ

APRILIA CLASSIC 50 2T 91-02, EUROPA 50 2T 91-02, PEGASO 50 2T 91-02, RED ROSE 50 2T 91-02, RS 50 2T 91-02
MALAGUTI FIFTY EVOLUTION 50 2T 90-94
MINARELLI AM 3-4-5-6 50 2T 91-12
MOTOR HISPANIA FURIA 50 2T 91-02
YAMAHA DT R 50 2T 03-10, DT X 50 2T 03-10, TZR 50 2T 03-10

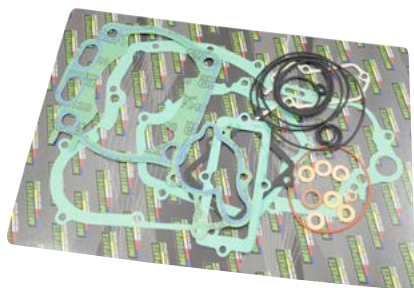

◀ cod. **YAMTP0128**
Serie guarnizioni smeriglio

APPLICABILITÀ

YAMAHA DT 125 R/RE/X 125 2T 93-94, TDR 125 R 125 2T 94-94, TZR RR 125 2T 94-95

◀ cod. **YAMTP0145**
Serie guarnizioni smeriglio

APPLICABILITÀ

YAMAHA DT R 125 2T 99-06

◀ cod. **YAMTP0149**
Serie guarnizioni smeriglio

APPLICABILITÀ

YAMAHA YZ 125 2T 05-20

◀ cod. **YAMTP0206**
Serie guarnizioni smeriglio

APPLICABILITÀ

YAMAHA YFZ S BLASTER 200 2T 88-04

◀ cod. **YAMTP0266**
Serie guarnizioni smeriglio

APPLICABILITÀ

YAMAHA YZ 250 2T 99-20, YZ X 250 2T 16-16

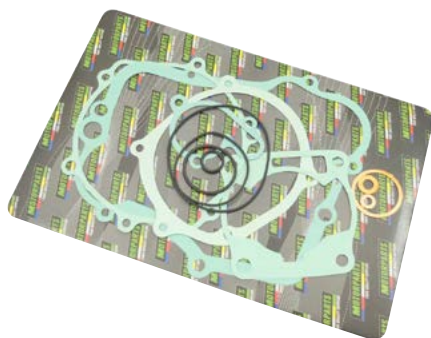

NOVITÀ

◀ **cod. APRFL0127**
Serie guarnizioni motore completa

APPLICABILITÀ

APRILIA CLASSIC 125 2T 95-01, MX 125 2T 04-06, RX 125 2T 95-01

◀ **cod. DERFL0004**
Serie guarnizioni motore completa

APPLICABILITÀ

APRILIA RS 50 2T 06-10, RS4 50 2T 11-13, RS4 REPLICA 50 2T 14-16, RX 50 2T 06-10, RX 50 2T 14-16, SX 50 2T 06-10, SX 50 2T 14-16, SX LIMITED EDITION 50 2T 14-16

DERBI GPR 2T 50 2T 13-13, GPR 2T EU2 50 2T 09-10, GPR NUDE & GPR NUDE TUNING 50 2T 06-08, GPR NUDE SPORT 50 2T 06-06, GPR R EU2 - GPR REPLICA EU2 50 2T 08-08, GPR RACING EU2 50 2T 06-06, GPR REPLICA & GPR R EU2 50 2T 06-06, GPR REPLICA 2T MALOSSÌ 50 2T 07-07, GPR REPLICA PESEK EU2 50 2T 07-07, SENDA HYP DRD EVO EU2 50 2T 08-09, SENDA HYP DRD EVO LIMITED EDITION EU2 50 2T 08-08, SENDA R DRD PRO EU2 50 2T 05-11, SENDA R DRD RACING EU2 50 2T 05-08, SENDA R DRD X-TREME 2T EU2 50 2T 14-15, SENDA R DRD X-TREME 2T EURO2 50 2T 10-12, SENDA R X-RACE 2T EU2 50 2T 10-10, SENDA R X-RACE EU2 50 2T 06-09, SENDA R X-TREME 2T EU2 50 2T 10-10, SENDA R X-TREME EU2 50 2T 05-08, SENDA SM DRD PRO EU2 50 2T 05-11, SENDA SM DRD PRO EU2 2VER 50 2T 05-08, SENDA SM DRD RACING EU2 50 2T 05-08, SENDA SM DRD RACING EU2 50 2T 10-13, SENDA SM DRD RACING LTD EU2 50 2T 07-07, SENDA SM DRD X-TREME 2T EU2 50 2T 14-15, SENDA SM DRD X-TREME 2T EU2 LIMITED ED 50 2T 14-15, SENDA SM X-RACE 2T EU2 50 2T 10-10, SENDA SM X-RACE EU2 50 2T 06-09, SENDA SM X-RACE EU2 2VER 50 2T 07-09, SENDA SM X-TREME 2T EU2 50 2T 10-10, SENDA SM X-TREME EU2 50 2T 05-08

GILERA RCR 50 2T 06-07, RCR 50 2T 11-12, RCR (CHE-SYC) 50 2T 13-15, SMT 50 2T 06-17, SMT RACING 50 2T 11-12

VALENTI RACING RME 50 2T 15-17, SM 50 2T 15-17

◀ **cod. HUSFL0128**
Serie guarnizioni motore completa

APPLICABILITÀ

HUSQVARNA CR (HUSQVARNA ENGINE) 125 2T 97-14, SM /S (HUSQVARNA ENGINE) 125 2T 98-14, WR (HUSQVARNA ENGINE) 125 2T 97-14, WRE 125 2T 98-12

◀ **cod. KTMFL0004**
Serie guarnizioni motore completa

APPLICABILITÀ

HUSQVARNA TC (KTM ENGINE) 85 2T 14-17

KTM MX 85 2T 03-09, SX 85 2T 03-17, XC 85 2T 03-13

◀ **cod. MINFL0022**
Serie guarnizioni motore completa

APPLICABILITÀ

APRILIA CLASSIC 50 2T 91-02, EUROPA 50 2T 91-02, PEGASO 50 2T 91-02, RED ROSE 50 2T 91-02, RS 50 2T 91-02

MALAGUTI FIFTY EVOLUTION 50 2T 90-94

MINARELLI AM 3-4-5-6 50 2T 91-12

MOTOR HISPANIA FURIA 50 2T 91-02

YAMAHA DT R 50 2T 03-10, DT X 50 2T 03-10, TZR 50 2T 03-10

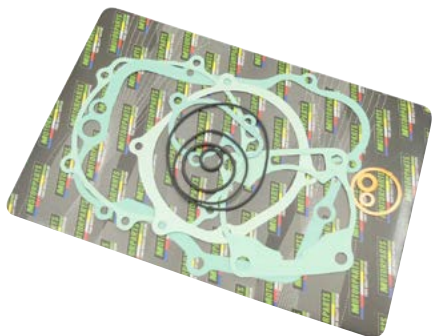

◀ cod. **PIAFL0003**
Serie guarnizioni motore completa

APPLICABILITÀ

PIAGGIO BRAVO 50 2T 70-93, CIAO 50 2T 70-93, CIAO MIX TEEN 50 2T 70-93, SI FL2 50 2T 70-93, SI MIX 50 2T 70-93

◀ cod. **PIAFL0007**
Serie guarnizioni motore completa

APPLICABILITÀ

PIAGGIO VESPA PK 50 2T 88-94, VESPA PK XL 50 2T 84-88, VESPA PK XL RUSH 50 2T 84-88

◀ cod. **PIAFL0138**
Serie guarnizioni motore completa

APPLICABILITÀ

PIAGGIO COSA 125 2T 88-97, PX E 125 2T 88-98, COSA 150 2T 88-97, PX E 150 2T 88-98

◀ cod. **PIAFL0150**
Serie guarnizioni motore completa

APPLICABILITÀ

PIAGGIO VESPA 150 2T 51-62

◀ cod. **PIAFL0200**
Serie guarnizioni motore completa

APPLICABILITÀ

PIAGGIO PE 200 2T 84-89, PX ARCOBALENO 200 2T 84-89, PX E ARCOBALENO 200 2T 84-97

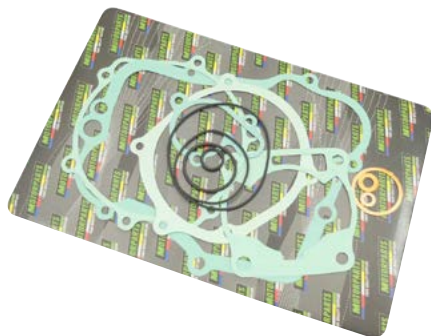

NOVITÀ

◀ cod. **PIAFL0701**
Serie guarnizioni motore completa

APPLICABILITÀ

PIAGGIO APE 50 2T 80-85

◀ cod. **PIAFL0709**
Serie guarnizioni motore completa

APPLICABILITÀ

PIAGGIO APE 220 2T 78-96, APE MP 220 2T 78-96, APE P 501 220 2T 78-96, APE P 601 220 2T 78-96, APE P 602 220 2T 82-83, APE P 703 220 2T 84-99, APE P 703 V 220 2T 84-99

◀ cod. **PIAFR0009**
Serie guarnizioni motore completa con ORing

APPLICABILITÀ

APRILIA MOJITO CUSTOM 2T MOTORE PIAGGIO 50 2T 04-10, SCARABEO 2T EU2 MOTORE PIAGGIO 50 2T 10-12, SCARABEO 2T NET 50 2T 09-10, SCARABEO STREET 50 2T 05-06, SCARABEO STREET 2T RESTYLING 50 2T 06-09, SPORT CITY ONE 2T 50 2T 08-11

DERBI ATLANTIS 2T 50 2T 10-10, ATLANTIS 2T EU2 50 2T 07-09, ATLANTIS O2 50 2T 02-02, ATLANTIS O2 BULLET 50 2T 03-05, ATLANTIS O2 CITY 50 2T 04-06, ATLANTIS O2 RED BULLET 50 2T 03-03, ATLANTIS O2 TWO CHIC 50 2T 05-05, BOULEVARD 2T 50 2T 09-14, SONAR 2T 50 2T 09-09

GILERA EASY MOVING 50 2T 95-96, ICE 50 2T 01-05, STALKER 50 2T 97-11, STALKER NAKED 50 2T 08-08, STALKER SPECIAL EDITION 50 2T 07-08, STORM 50 2T 94-95, STORM EURO 2 50 2T 07-07, TYPHOON 50 2T 94-97, TYPHOON X 50 2T 98-99, TYPHOON XR 50 2T 00-00

PIAGGIO DIESIS 50 2T 01-01, FLY 2T 50 2T 05-07, FLY 2T 50 2T 10-11, FREE 50 2T 92-94, FREE DELIVERY 50 2T 00-01, FREE FL 50 2T 95-02, LIBERTY 50 2T 97-05, LIBERTY 2T 50 2T 06-08, LIBERTY 2T PTT EU2 50 2T 04-05, LIBERTY 2T RST 50 2T 04-04, LIBERTY 2T SPORT 50 2T 06-08, LIBERTY MOC 2T & ELLE 50 2T 09-13, NRG POWER DT 50 2T 06-15, NRG POWER DT SERIE SPECIALE 50 2T 07-08, SFERA 50 2T 91-93, SFERA MAQUILLAGE 2.50 2T 94-94, SFERA RST 50 2T 95-97, TYPHOON 50 2T 01-11, TYPHOON 2T E2 50 2T 10-12, TYPHOON 2T E3 CH 50 2T 11-11, VESPA ET2 50 2T 97-05, VESPA ET2 INIEZIONE 50 2T 97-00, VESPA LX 2T 50 2T 05-13, VESPA LX 2T TOURING & 30KM 50 2T 10-13, VESPA LXV 2T 50 2T 06-09, VESPA LXV 2T NAVY 50 2T 08-08, VESPA S 2T & COLLEGE 50 2T 07-12, ZIP 50 2T 92-93, ZIP 50 2T 95-96, ZIP BIMODALE 50 2T 94-97, ZIP FAST RIDER 50 2T 93-94, ZIP FAST RIDER RST 50 2T 96-97, ZIP RST 50 2T 96-99

◀ cod. **PIAFR0138**
Serie guarnizioni motore completa con ORing

APPLICABILITÀ

PIAGGIO COSA 2 125 2T 91-97, COSA CL, CLX 125 2T 88-91, VESPA PX E ARCOBALENO 125 2T 81-97, COSA 2 150 2T 91-97, COSA CL, CLX 150 2T 88-91, VESPA PX E ARCOBALENO 150 2T 81-97

NOVITÀ

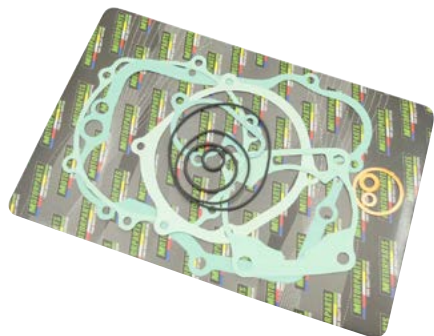

◀ cod. **YAMFL0004**
Serie guarnizioni motore completa

APPLICABILITÀ

APRILIA AMICO 50 2T 94-94, AMICO 50 2T 96-98, AMICO GL/GLE 50 2T 93-95, AMICO LX/SPORT/CAT 50 2T 92-93, SR (VERTICALE) 50 2T 93-93, SR STEALTH 50 2T 97-00

MBK BOOSTER 50 2T 90-04, BOOSTER 50 2T 90-94, BOOSTER EURO 2 50 2T 04-04, BOOSTER NG 50 2T 95-03, BOOSTER ROCKET 50 2T 97-98, BOOSTER SPIRIT 50 2T 96-00, BOOSTER SPIRIT 50 2T 03-03, BOOSTER SPIRIT EURO2 50 2T 03-03, BOOSTER TRACK 50 2T 96-98, STUNT 50 2T 00-02

YAMAHA BW'S 50 2T 97-16, BW'S BUMP 50 2T 97-98, BW'S EASY 50 2T 13-13, BW'S NAKED 50 2T 03-04, BW'S NAKED 50 2T 09-16, BW'S NEXT GENERATION 50 2T 97-06, BW'S ORIGINAL 50 2T 99-02, BW'S ORIGINAL EURO 2 50 2T 03-03, RS SPY 50 2T 95-98, SLIDER 50 2T 00-02, ZUMA 50 2T 97-01

◀ cod. **YAMFL0087**
Serie guarnizioni motore completa

APPLICABILITÀ

YAMAHA YZ LC-LW 80 2T 94-97, YZ N-LW 80 2T 01-01, YZ 85 2T 01-17, YZ-LW 85 2T 18-18

◀ cod. **YAMFL0133**
Serie guarnizioni motore completa

APPLICABILITÀ

YAMAHA DT 125 R/RE/X 125 2T 93-94, TDR 125 R 125 2T 94-94, TZR RR 125 2T 94-95

◀ cod. **YAMFL0149**
Serie guarnizioni motore completa

APPLICABILITÀ

YAMAHA YZ 125 2T 05-20

◀ cod. **YAMFL0266**
Serie guarnizioni motore completa

APPLICABILITÀ

YAMAHA YZ 250 2T 99-20, YZ X 250 2T 16-16



◀ cod. **AA00780**
Perno pompa acqua con girante motore scooter 50 cc Minarelli/Yamaha



◀ cod. **AA00785**
Traino per girante pompa acqua motore scooter 50 cc Minarelli/Yamaha



◀ cod. **AA00786**
Gommino su perno traino pompa acqua motore scooter 50 cc Minarelli/Yamaha



◀ cod. **AA00787**
Perno per traino girante pompa acqua motore scooter 50 cc Minarelli/Yamaha



◀ cod. **AA00797**
Perno lungo per traino girante pompa acqua motore scooter 50 cc Minarelli/Yamaha Aerox '06-'16

APPLICABILITÀ

YAMAHA AEROX 50 2T 06-16, AEROX NAKED 50 2T 13-16

◀ cod. **AA00788**
Kit revisione pompa acqua per scooter 50 cc Minarelli/Yamaha

APPLICABILITÀ

APRILIA AREA 51 50 2T 98-00, GULLIVER LC 50 2T 96-98, RALLY LIQUID COOLED 50 2T 96-99, SONIC GP 50 2T 98-08, SR LIQUID COOLED 50 2T 94-96, SR RACING 50 2T 97-99, SR STEALTH 50 2T 97-00
BENELLI 491 RACING 50 2T 98-99, 491 RR 50 2T 99-01, 491 SP 50 2T 99-99, 491 SPORT 50 2T 98-99, K2 LIQUID COOLED 50 2T 98-01
BETA ARK LC 50 2T 96-08, EIKON 50 2T 99-03
ITALJET DRAGSTER 50 2T 98-02

MALAGUTI F12 PHANTOM EURO 2 50 2T 02-02, F12 PHANTOM LC 50 2T 94-98, F12 PHANTOM LC EURO 2,2,3 50 2T 03-04, F12 R PHANTOM LC 50 2T 07-10, F12 RESTYLING EURO 1 50 2T 99-02, F12 RESTYLING LC EURO 2 50 2T 06-06, F15 FIRE FOX 50 2T 96-98, F15 FIRE FOX EURO 2 50 2T 02-06, F15 FIRE FOX EURO 2,2,3 50 2T 03-04
MBK MACH 6 LC 50 2T 02-04, NITRO 50 2T 97-04, NITRO EURO 2 50 2T 03-03
YAMAHA AEROX 50 2T 97-02, AEROX 50 2T 04-16, AEROX EURO 2 50 2T 03-03, AEROX NAKED 50 2T 13-16, AEROX R 50 2T 99-00, JOG R LC 50 2T 02-15

RICAMBIO

AA00784 Paraolio BA 10 18 4 Corcos

◀ cod. **AA00789**
Kit revisione pompa acqua per motore Minarelli AM6

APPLICABILITÀ

APRILIA CLASSIC 50 2T 92-99, EUROPA 50 2T 91-92, MX 50 2T 04-04, MX MOTARD 50 2T 95-03, PEGASO 50 2T 92-94, RS 50 2T 91-05, RX 50 2T 03-04, RX 3-5 MARCE 50 2T 91-94, RX ENDURO 50 2T 95-03, RX RACING 50 2T 03-06, TUONO 50 2T 03-04
BETA RR 2T 50 EU4 50 2T 18-20, RR 50 RACING EU4 50 2T 18-20, RR ALU 50 2T 08-12, RR ENDURO 50 2T 06-17, RR MOTARD 50 2T 06-17
CH HUSQUAR-SM 50 2T 00-10, WR 50 2T 00-10, WSM 50 2T 00-10
NA
CMC ENDURO 50 2T 11-11, MOTARD 50 2T 11-11
FANTIC CABALLERO MOTARD 50 2T 06-10, CABALLERO REGOLARITÀ 50 2T 06-10, ENDURO COMPETITION EU4 50 2T 18-20, ENDURO PERFORMANCE EU4 50 2T 18-20, MOTARD COMPETITION EU4 50 2T 18-20, MOTARD PERFORMANCE EU4 50 2T 18-20
HM BAJA, DERAPAGE BASIC 50 2T 10-11, CMC 50 2T 10-11, CRE BAJA RR, DERAPAGE RR 50 2T 07-11, CRE BAJA, DERAPAGE 50 2T 07-11, CRE SIX COMPETITION 50 2T 10-11, CRE SIX, BAIA, DERAPAGE 50 2T 95-06, CRE SIX, DERAPAGE COMPETITION 50 2T 07-09, DERAPAGE COMPETITION 50 2T 10-11
MALAGUTI CNK DRAGON 50 2T 05-07, FIFTY EVOLUTION 50 2T 90-93, XSM 50 2T 03-03, XTM 50 2T 03-03
MBK X LIMIT 50 2T 03-04, X POWER 50 2T 03-04

MINARELLI MOTORE AM 3-4-5 50 2T 91-95, MOTORE AM 6 1° SERIE 50 2T 96-11, MOTORE AM 6 2° SERIE 50 2T 12-18
MOTORHISPANIA FURIA 50 2T 97-00, FURIA MAX 50 2T 10-12, RX 50 2T 09-12, RX R 50 2T 09-12
PEUGEOT SUPERMOTARD 50 2T 90-02, XP6 TRAIL S/AVV. ELETTRICO 50 2T 90-02, XR6 RACING CAT. C/AVV.ELETT. 50 2T 90-02
RIEJU MRT 50 2T 09-12, MRT 50 EU4 50 2T 18-20, MRT PRO 50 2T 09-12, MRT PRO EU4 50 2T 18-20, MRT PRO REPLICIA EU4 50 2T 18-20, MRT PRO REPLICIA SM EU4 50 2T 18-20, MRT PRO SM 50 2T 09-12, MRT PRO SM EU4 50 2T 18-20, MRT SM 50 2T 09-12, MRT SM EU4 50 2T 18-20, MRT TROPHY EU4 50 2T 18-20, MRX 50 2T 01-04, MRX PRO 50 2T 01-04, RR 50 2T 05-06, RS1 50 2T 98-01, RS2 MATRIX 50 2T 05-06, RS2 MATRIX PRO 50 2T 05-06, RS2 NAKED 50 2T 04-05, RS3 EU4 50 2T 18-20, RS3 MKD EU4 50 2T 18-20, SMX E.S./K.S. 50 2T 01-01, SMX PRO E.S./K.S. 50 2T 03-03, SPIKE 50 2T 98-01
SHERCO FACTORY SE-R EU4 50 2T 18-20, FACTORY SE-RS EU4 50 2T 18-20, FACTORY SILVER SM-R EU4 50 2T 18-20, FACTORY SILVER SM-RS EU4 50 2T 18-20, FACTORY SM-R EU4 50 2T 18-20, FACTORY SM-RS EU4 50 2T 18-20, HRD ENDURO 50 2T 09-13, HRD MOTARD 50 2T 09-13
VENT BAJA 50 2T 18-20, BAJA RR 50 2T 18-20, DERAPAGE 50 2T 18-20, DERAPAGE RR 50 2T 18-20
YAMAHA DT R 50 2T 03-11, DT RSM 50 2T 03-05, DT X 50 2T 06-11, TZR 50 2T 03-08, TZR 50 2T 10-11, TZR RR 50 2T 05-05

KIT REVISIONE POMPA ACQUA



◀ cod. **AA00792**
Corpo pompa acqua per motore Minarelli AM6



◀ cod. **AA00796**
Kit revisione pompa acqua per motore scooter 50 cc Piaggio/Gilera

APPLICABILITÀ

APRILIA SR CARBURATORE 50 2T 14-14, SR MOTARD 50 2T 12-14, SR R 50 2T 04-09, SR R FACTORY CARBURATORE 50 2T 10-14, SR R FACTORY IE 50 2T 10-14, SR R FACTORY IE 50 2T-IE 10-12, SR STREET CARBURATORE 50 2T 03-12

DERBI GP1 50 2T 01-03, GP1 EU 2.50 2T 05-05, GP1 OPEN EU2 50 2T 06-09, GP1 RACE EU2 50 2T 05-07

GILERA DNA 50 2T 00-02, DNA 50 2T 05-07, DNA GP EXPERIENCE 50 2T 03-04, RUNNER 50 2T 97-00, RUNNER POGGIALI 50 2T 02-02, RUNNER PURE JET 50 2T-IE 02-07, RUNNER PURE JET 50 2T-IE 10-11, RUNNER PURE JET ST 50 2T-IE 08-08, RUNNER SP 50 2T 02-07, RUNNER SP 50 2T 10-12, RUNNER SP SPECIAL EDITION 50 2T 07-07, RUNNER SP ST & SIMONCELLI 50 2T 08-09

PIAGGIO NRG 50 2T 94-96, NRG EXTREME LC 50 2T 99-00, NRG MC3 50 2T 01-04, NRG POWER DD 50 2T 05-17, NRG POWER DD SERIE SPECIALE 50 2T 07-12, NRG POWER PUREJET 50 2T-IE 04-11, NRG PUREJET 50 2T-IE 02-04, NRG PUREJET 50 2T-IE 10-10, NRG RST MC2 50 2T 96-98, NTT 50 2T 95-96, QUARTZ 50 2T 92-96, ZIP 2T 50 2T 08-13, ZIP LC 50 2T 00-04, ZIP SP 50 2T 96-04, ZIP SP EURO 2.50 2T 06-13

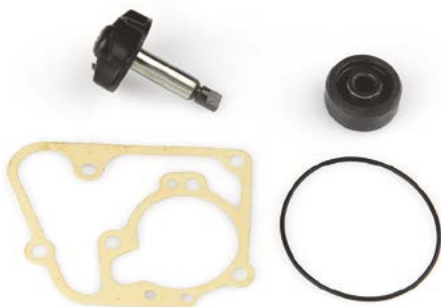

◀ cod. **AA00805**
Kit revisione pompa acqua per motore scooter Minarelli/Yamaha YP 125/150/180 cc

APPLICABILITÀ

BENELLI VELVET 125 4T 99-01, VELVET 150 4T 99-01

ITALJET JUPITER 125 4T 01-02, MILLENNIUM 125 4T 00-02, JUPITER 150 4T 01-02, MILLENNIUM 150 4T 00-02

MALAGUTI MADISON 125 4T 99-01, MADISON R RESTYLING 125 4T 02-02, MADISON R RESTYLING EU2 125 4T 03-04, PHANTOM MAX 125 4T 03-03, MADISON T 150 4T 99-01

MBK DOODO 125 4T 00-00, SKYLINER 125 4T 98-02, SKYLINER E 125 4T 03-03, THUNDER 125 4T 01-02, DOODO 150 4T 01-02, SKYLINER 150 4T 00-02, THUNDER 150 4T 01-02, SKYLINER E 180 4T 03-03

YAMAHA MAJESTY 125 4T 98-00, MAJESTY (5NR1) 125 4T 01-01, MAJESTY (5NR8) 125 4T 02-02, MAJESTY E 125 4T 03-09, MAXSTER 125 4T 01-02, TE0'S 125 4T 00-00, MAJESTY 150 4T 00-00, MAJESTY (5NS1) 150 4T 01-01, MAJESTY (5NS6) 150 4T 02-02, MAXSTER 150 4T 01-02, TE0'S 150 4T 01-02, MAJESTY E 180 4T 03-06



◀ cod. **AA00806**
Kit revisione pompa acqua per motore scooter Minarelli/Yamaha YP 250/270 cc

APPLICABILITÀ

APRILIA LEONARDO 250 4T 99-04, LEONARDO ST 250 4T 01-01, LEONARDO 300 4T 02-04

BENELLI VELVET 250 4T 99-03

ITALJET JUPITER 250 4T 00-02

MALAGUTI MADISON S 250 4T 99-01, PASSWORD 250 4T 05-06, PASSWORD EU3 250 4T 07-08

MBK SKYLINER 250 4T 00-03, SKYLINER ABS 250 4T 03-03, KILIBRE 300 4T 03-06

YAMAHA MAJESTY 250 4T 96-03, MAJESTY ABS 250 4T 03-03, MAJESTY DX 250 4T 98-99, X-CITY 250 4T 07-15, X-MAX 250 4T 05-16, X-MAX ABS 250 4T 14-15, VERSITY 300 4T 03-06



◀ cod. **AA00808**
Kit revisione pompa acqua Katana-Ditech 13 mm 2SR

APPLICABILITÀ

SUZUKI KATANA K1-K4 50 2T 01-04, KATANA V-Y 50 2T 97-00



◀ cod. **AA00809**
 Kit revisione pompa acqua Katana-Ditech 50 cc con girante a pale basse 7 mm

APPLICABILITÀ

APRILIA SR DITECH EU2 50 2T-IE 02-04, SR H2O CARBURATORE 50 2T 00-03, SR H2O DITECH 50 2T-IE 00-04, SR R FACTORY MOTORE APRILIA 50 2T-IE 05-05 **SUZUKI** KATANA K1-K4 50 2T 01-04, ZILLION UX 50 2T 99-99



◀ cod. **AA00810**
 Kit revisione pompa acqua Aprilia Scarabeo 125/150 cc

APPLICABILITÀ

APRILIA LEONARDO 125 4T 99-02, LEONARDO ST 125 4T 03-04, SCARABEO 125 4T 99-03, LEONARDO 150 4T 99-02, SCARABEO 150 4T 99-03 **BMW** C1 125 4T 00-03



◀ cod. **AA00811**
 Kit revisione pompa acqua Aprilia Leonardo 125/150 cc

APPLICABILITÀ

APRILIA LEONARDO 125 4T 96-98, LEONARDO 150 4T 96-98



◀ cod. **AA00812**
 Kit revisione pompa acqua Honda Pantheon 125/150 cc 2T

APPLICABILITÀ

HONDA PANTHEON [FES] 125 2T 98-02, PANTHEON [FES] 150 2T 98-02



◀ cod. **AA00813**
 Kit revisione pompa acqua Honda SH 125/150 cc 4T

APPLICABILITÀ

HONDA @ [NES] 125 4T 00-06, DYLAN [SES] 125 4T 02-04, PANTHEON IE [FES] 125 4T-2V 03-05, PS I [PES] 125 4T 06-10, SH 125 4T-2V 01-04, SH IE SCOOPY 125 4T-2V 05-12, SILVER WING [FES] 125 4T-2V 07-12, @ [NES] 150 4T 00-06, DYLAN [SES] 150 4T 02-04, PANTHEON IE [FES] 150 4T-2V 03-05, PS I [PES] 150 4T 06-10, SH 150 4T-2V 01-04, SH IE SCOOPY 150 4T 05-12, SILVER WING [FES] 150 4T-2V 07-12



◀ cod. **AA00814**
Kit revisione pompa acqua Honda Foresight 250 cc 4T

APPLICABILITÀ

HONDA FORESIGHT [FES] 250 4T 98-99, FORESIGHT [FES] D.D. 250 4T 00-05



◀ cod. **AA00815**
Kit revisione pompa acqua Kymco 125/150 cc 4T

APPLICABILITÀ

KYMCO B&W 125 4T 00-00, B&W EU2 125 4T 03-04, DINK 125 4T 97-98, DINK CLASSIC 125 4T 02-02, DINK CLASSIC EU2 125 4T 03-03, DINK LX 125 4T 98-00, GRAND DINK 125 4T 01-02, GRAND DINK EU2 125 4T 03-04, B&W 150 4T 00-00, B&W EU2 150 4T 03-04, DINK 150 4T 97-98, DINK CLASSIC 150 4T 02-02, DINK CLASSIC EU2 150 4T 03-03, DINK LX 150 4T 98-00, GRAND DINK 150 4T 01-02, GRAND DINK EU2 150 4T 03-04, DINK CLASSIC 200 4T 04-04



◀ cod. **AA00816**
Kit revisione pompa acqua Kymco 250 cc 4T

APPLICABILITÀ

KYMCO B&W 250 4T 00-00, B&W EU2 250 4T 03-03, GRAND DINK 250 4T 01-02, GRAND DINK EU2 250 4T 03-04, PEOPLE LC 250 4T 03-04, PEOPLE S 250 4T 06-06, PEOPLE S I 250 4T 07-07, X CITING 250 4T 05-05, X CITING I 250 4T 06-07, YUP 250 4T 03-03, PEOPLE S I 300 4T 08-08, X CITING I 300 4T 08-08, X CITING I R 300 4T 08-09



◀ cod. **AA00817**
Kit revisione pompa acqua Piaggio/Aprilia 125/200 cc

APPLICABILITÀ

APRILIA ATLANTIC 125 4T 03-05, ATLANTIC ARRECIFE 125 4T 03-05, SCARABEO 125 4T 04-06, SPORT CITY 125 4T 04-06, SCARABEO 150 4T 04-06, ATLANTIC 200 4T 03-05, ATLANTIC ARRECIFE 200 4T 03-05, SPORT CITY 200 4T 04-06

GILERA DNA 125 4T 01-01, RUNNER VX 125 4T 00-06, RUNNER 180 4T 00-01, RUNNER VXR 180 4T 00-01

PIAGGIO BEVERLY 125 4T 01-03, BEVERLY RST 125 4T 04-05, CARNABY 125 4T 07-10, HEXAGON GTX 125 4T 00-00, SUPER HEXAGON GTX 125 4T 01-02, VESPA GRANTURISMO 125 4T 03-05, X8 125 4T 04-04, X9 125 4T 01-02, X9 EVOLUTION 125 4T 03-03, HEXAGON GTX 180 4T 00-00, SUPER HEXAGON GTX 125 180 4T 01-02, X9 AMALFI 180 4T 00-03, BEVERLY 200 4T 01-03, X8 200 4T 04-04, X9 200 4T 02-03, X9 EVOLUTION 200 4T 03-03

RENAULT FULLTIME 125 4T 02-03



◀ cod. **AA00818**
Kit revisione pompa acqua Yamaha Majesty 400 cc

APPLICABILITÀ

YAMAHA MAJESTY 400 4T 04-08, MAJESTY ABS 400 4T 07-08, X-MAX 400 4T-4V 13-16, X-MAX ABS 400 4T-4V 14-17, X-MAX IRONMAX ABS 400 4T-4V 16-16, X-MAX MOMODESIGN 400 4T-4V 14-14, X-MAX MOMODESIGN ABS 400 4T-4V 14-14, X-MAX RA 400 4T-4V 18-18



◀ cod. **AA00819**
Kit revisione pompa acqua Suzuki Burgman 125/150 /200/250/400 cc

APPLICABILITÀ

SUZUKI EPICURO 125 4T 99-01, UH BURGMAN K2/K6 125 4T 02-06, UH BURGMAN K7/L0 125 4T 07-10, UH BURGMAN L1 125 4T 11-11, EPICURO 150 4T 99-01, UH BURGMAN K2/K6 150 4T 02-06, UH BURGMAN K7/L0 200 4T 07-10, UH BURGMAN L1 200 4T 11-12, AN BURGMAN K1/K2 250 4T 01-02, AN BURGMAN K3/K6 250 4T 03-06, AN BURGMAN W/X/Y 250 4T 98-00, AN BURGMAN K3/K6 400 4T 03-06, AN BURGMAN X/K2 40



◀ cod. **AA00820**
Kit revisione pompa acqua Yamaha T-Max '04-'11 (5vu)

APPLICABILITÀ

YAMAHA T-MAX 4B5 500 4T 09-11, T-MAX 4B5 ABS 500 4T 08-11, T-MAX 5VU 500 4T 04-08, T-MAX 5VU ABS 500 4T 05-07, T-MAX 5VU BLACK MAX 500 4T 06-06, T-MAX 5VU BLACK MAX - NIGHT MAX 500 4T 07-07



◀ cod. **AA00822**
Kit revisione pompa acqua Honda SH 300 cc

APPLICABILITÀ

HONDA SH IE SCOOPY 300 4T-4V 07-19

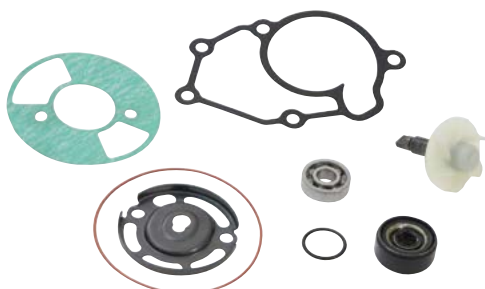

◀ cod. **AA00823**
Kit revisione pompa acqua Yamaha X-Max 125 cc

APPLICABILITÀ

MBK CITYLINER EU3 125 4T-4V 08-10, SKYCRUISER 125 4T-4V 07-07

YAMAHA X-CITY EU3 125 4T-4V 08-11, X-MAX R 125 4T-4V 06-16, X-MAX R ABS 125 4T-4V 11-11, X-MAX RA ABS 125 4T-4V 13-16



◀ cod. **AA00824**
Kit revisione pompa acqua Piaggio 500 cc Euro 3

APPLICABILITÀ

APRILIA SCARABEO LIGHT 400 4T 06-08, SCARABEO LIGHT 500 4T 06-08

GILERA FUOCO IE EU3 500 4T 07-13, NEXUS EU3 500 4T 06-08

PIAGGIO BEVERLY EU3 400 4T 06-07, BEVERLY TOURER EU3 400 4T 08-10, MP3 400 4T 07-08, MP3 IE LT TOURING 400 4T 11-11, MP3 IE LT/SPORT 400 4T 08-10, MP3 MIC 400 4T 08-10, MP3 RL TOURING 400 4T 11-11, X-EVO 400 4T 07-11, BEVERLY CRUISER 500 4T 07-12, BEVERLY IE EU3 500 4T 06-08, MP3 LT SPORT/BUSINESS 500 4T 11-13, MP3 RL SPORT-BUSINESS 500 4T 11-12

KIT REVISIONE POMPA ACQUA



cod. AA00825 Kit revisione pompa acqua Derbi d50b0 (motore Piaggio)

APPLICABILITÀ

APRILIA RS 50 2T 06-10, RS4 50 2T 11-13, RS4 REPLICA 50 2T 14-16, RX 50 2T 06-10, RX 50 2T 14-16, SX 50 2T 06-16, SX LIMITED EDITION 50 2T 14-16

DERBI GPR 2T 50 2T 13-13, GPR 2T EU2 50 2T 09-10, GPR NUDE & GPR NUDE TUNING 50 2T 06-08, GPR NUDE SPORT 50 2T 06-06, GPR R EU2 - GPR REPLICA EU2 50 2T 08-08, GPR RACING EU2 50 2T 06-06, GPR REPLICA & GPR R EU2 50 2T 06-06, GPR REPLICA 2T MALOSSÌ 50 2T 07-07, GPR REPLICA PESEK EU2 50 2T 07-07, SENDA HYP DRD EVO EU2 50 2T 08-09, SENDA HYP DRD EVO LIMITED EDITION EU2 50 2T 08-08, SENDA R DRD PRO EU2 50 2T 05-11, SENDA R DRD RACING EU2 50 2T 05-08, SENDA R DRD X-TREME 2T EU2 50 2T 14-15, SENDA R DRD X-TREME 2T EURO2 50 2T 10-12, SENDA R X-RACE 2T EU2 50 2T 10-10, SENDA R X-RACE EU2 50 2T 06-09, SENDA R X-TREME 2T EU2 50 2T 10-10,

SENDA R X-TREME EU2 50 2T 05-08, SENDA SM DRD PRO EU2 50 2T 05-11, SENDA SM DRD PRO EU2 2VER 50 2T 05-08, SENDA SM DRD RACING EU2 50 2T 05-08, SENDA SM DRD RACING EU2 50 2T 10-13, SENDA SM DRD RACING LTD EU2 50 2T 07-07, SENDA SM DRD X-TREME 2T EU2 50 2T 14-15, SENDA SM DRD X-TREME 2T EU2 LIMITED ED 50 2T 14-15, SENDA SM X-RACE 2T EU2 50 2T 10-10, SENDA SM X-RACE EU2 50 2T 06-09, SENDA SM X-RACE EU2 2VER 50 2T 07-09, SENDA SM X-TREME 2T EU2 50 2T 10-10, SENDA SM X-TREME EU2 50 2T 05-08

GILERA RCR 50 2T 06-07, RCR 50 2T 11-12, RCR (CHE-SYC) 50 2T 13-15, SMT 50 2T 06-17, SMT RACING 50 2T 11-12

VALENTI RACING RME 50 2T 15-17, SM 50 2T 15-17

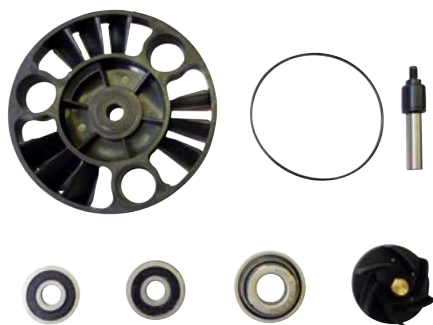

cod. AA00826 Kit revisione pompa acqua Piaggio/Aprilia 125/200 cc Euro 3

APPLICABILITÀ

APRILIA ATLANTIC EU3 125 4T 06-08, ATLANTIC EU3 125 4T 10-12, SCARABEO EU3 125 4T 06-07, SPORT CITY CUBE 125 4T 08-10, SPORT CITY EU3 125 4T 06-08, SPORT CITY STREET 125 4T 12-12

DERBI GP1 EU 2 125 4T 06-06, GP1 LOW SEAT EU3 125 4T 07-08, RAMBLA 125 4T 08-09, RAMBLA EU3 2VER 125 4T 08-08

GILERA NEXUS EU3 125 4T 07-08, RUNNER 4T ST EU3 125 4T 08-16, RUNNER VX 4T EU3 125 4T 06-07, RUNNER VX RACE 125 4T 06-06, RUNNER VX SC 125 4T 06-07, RUNNER VXR 200 4T 02-06, RUNNER VXR 4T ST EU3 200 4T 08-11, RUNNER VXR EU3 200 4T 07-07

PIAGGIO BEVERLY EU3 125 4T 07-08, BEVERLY EURO 3 MIC 125 4T 07-07, BEVERLY EURO 3 SPORT 125 4T 07-08, BEVERLY RST 125 4T 05-07, BEVERLY RST 4T 4V IE EU3 125 4T 10-15, BEVERLY TOURER EU3 125 4T 07-10, MP3 125 4T 06-08, VESPA GRANTURISMO 125 4T 06-07, VESPA GRANTURISMO EU3 125 4T 06-07, VESPA GTS EU3 125 4T 07-12, VESPA GTV 125 4T 06-08, VESPA GTV 4T NAVY EU3 125 4T 08-08, X-EVO 125 4T 07-16, X7 EU3 125 4T 08-08, X8 125 4T 05-06, X8 PREMIUM EU2 125 4T 06-06, X8 PREMIUM EU3 125 4T 06-07, X9 EVOLUTION 125 4T 05-06, X9 EVOLUTION EU3 125 4T 07-07, CARNABY 200 4T 07-08, VESPA GRANTURISMO 200 4T 06-07, X8 200 4T 05-07



cod. AA00827 Kit revisione pompa acqua Derbi ebs050 (vecchio modello)

APPLICABILITÀ

DERBI BULTACO LOBITO 50 2T 98-01, GPR NUDE 50 2T 04-05, GPR 50 2T 97-00, GPR RACING 50 2T 04-05, GPR REPLICA 50 2T 99-01, GPR REPLICA RACING 50 2T 02-03, GPR REPLICA RACING EU2 50 2T 05-05, SENDA BLACK EDITION 50 2T 03-03, SENDA R 50 2T 99-01, SENDA R DRD BLACK DEVIL 2A EDIZIONE 50 2T 03-03, SENDA R DRD EU1 EU1R 50 2T 02-02, SENDA R DRD RACING 50 2T 04-05, SENDA R DRD RACING LTD 50 2T 05-05, SENDA R RACER 50 2T 03-03, SENDA R X-RACE 50 2T 04-05, SENDA R X-TREME 50 2T 03-03, SENDA R X-TREME 50 2T 05-05, SENDA R X-TREME EU2 50 2T 04-04, SENDA SM 50 2T 00-01, SENDA SM DRD EDITION BLACK 50 2T 05-05, SENDA SM DRD EU1 EU1R 50 2T 02-03, SENDA SM DRD RACING 50 2T 04-05, SENDA SM DRD RACING LTD 50 2T 05-05, SENDA SM X-RACE 50 2T 04-05, SENDA SM X-TREME 50 2T 02-03, SENDA SM X-TREME EU2 50 2T 04-04, SENDA SM X-TREME EU2 2A EDIZIONE 50 2T 05-05

GILERA GSM 50 2T 01-01, RCR 50 2T 03-03, SMT 50 2T 03-03



cod. AA00828 Kit revisione pompa acqua Piaggio 300cc

APPLICABILITÀ

APRILIA ATLANTIC 250 4T 03-05, ATLANTIC EU3 250 4T 06-08, SCARABEO 250 4T 04-06, SCARABEO LIGHT 250 4T 06-08, ATLANTIC 300 4T 10-11, SCARABEO LIGHT 300 4T 09-10, SPORT CITY STREET 300 4T 4V 12-12, SR MAX 300 4T 11-14

DERBI RAMBLA 250 4T 08-09, RAMBLA EU3 2VER 250 4T 08-08, RAMBLA 300 4T 10-11

GILERA NEXUS EU3 250 4T 06-07, NEXUS SP EU3 250 4T 06-07, OREGON 250 4T 06-10, NEXUS EU3 300 4T 08-11

PIAGGIO BEVERLY 250 4T 05-07, BEVERLY CRUISER 250 4T 07-09, BEVERLY EURO 3 MIC 250 4T 07-07, BEVERLY IE EU3 250 4T 06-08, BEVERLY SPORT 250 4T 06-08, BEVERLY TOURER EU3 250 4T 07-09, CARNABY 250 4T 08-09, MP3 250 4T 06-08, MP3 LT 250 4T 08-09, MP3 MIC 250 4T 08-09, VESPA GT 60 EU3 250 4T 06-07, VESPA GTS 250 4T 05-16, VESPA GTS ABS 250 4T 05-12, VESPA GTV 250 4T 06-09, VESPA GTV 4T NAVY EU3 250 4T 07-07, X-EVO 250 4T 07-16, X7 EU3 250 4T 08-08, X8 EU3 250 4T 05-08, X9 EVOLUTION 250 4T 06-06, BEVERLY RST 4T 4V IE EU3 300 4T 10-16, BEVERLY TOURER EU3 300 4T 09-10, CARNABY CRUISER 300 4T 09-12, MP3 4T 4V IE LT IBRIDO 300 4T 10-11, MP3 IE LT 300 4T 10-11, MP3 IE LT TOURING 300 4T 11-13, MP3 IE LT/SPORT 300 4T 11-14, MP3 IE MIC 300 4T 10-11, MP3 IE TOURING 300 4T 11-12, MP3 YOURBAN ERL 300 4T 11-15, MP3 YOURBAN LT ERL 300 4T 11-12, VESPA GTS IE TOURING 300 4T 11-12, VESPA GTS SUPER 300 4T 08-16, VESPA GTS SUPER SPORT 300 4T 10-13, VESPA GTV 4T 4V IE 300 4T 10-13, VESPA GTV VIA MONTENAPOLEONE 300 4T 10-10, X7 EVO IE EU3 300 4T 09-10



◀ cod. **AA00829**
Kit revisione pompa acqua Piaggio Beverly 350 cc

APPLICABILITÀ

PIAGGIO BEVERLY 4T 4V IE EU3 350 4T 11-14, BEVERLY 4T ST IE ABS 350 4T 16-16, X10 4T 4V IE EURO3 350 4T 12-15

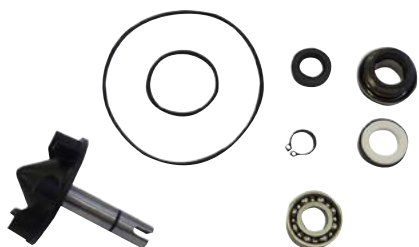

◀ cod. **AA00831**
Kit revisione pompa acqua Yamaha T-Max 530 cc

APPLICABILITÀ

YAMAHA T-MAX 59C 530 4T 12-16, T-MAX 59C ABS 530 4T 12-16, T-MAX 59C SP 530 4T 15-15, T-MAX 59C SP ABS 530 4T 15-16, XP530-A T-MAX SX 530 4T 17-19, XP530D-A T-MAX DX 530 4T 17-19, XP530E-A T-MAX 530 4T 17-18



◀ cod. **AA00832**
Kit Revisione Pompa Acqua Yamaha Xenter 125/150 cc

APPLICABILITÀ

YAMAHA XC125R MAJESTY S 125 4T 14-14, XENTER 125 4T 12-17, XENTER 150 4T 12-16



◀ cod. **AA00833**
Kit Revisione Pompa Acqua Kymco Downtown 300 cc

APPLICABILITÀ

KYMCO DOWNTOWN I 200 4T 10-10, PEOPLE GTI 200 4T 10-10, DOWNTOWN ABS 300 4T 10-10, DOWNTOWN I 300 4T 09-09, DOWNTOWN I 300 4T 11-11, DOWNTOWN I ABS 300 4T 11-16, PEOPLE GTI 300 4T 10-11

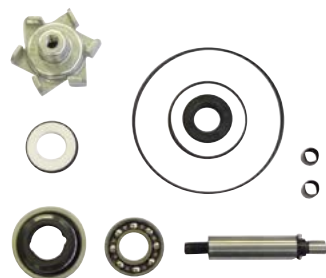

◀ cod. **AA00834**
Kit Revisione Pompa Acqua Honda PCX 125 cc

APPLICABILITÀ

HONDA PCX 125 4T-2V 10-13, SH I ABS 125 4T-2V 13-17, PCX 150 4T-2V 13-17, SH I ABS 150 4T-2V 13-17



◀ cod. **AA00835**
Kit Revisione Pompa Acqua Kymco Downtown 125 cc

APPLICABILITÀ

KYMCO DOWNTOWN I 125 4T 09-16



◀ cod. **AA00836**
Kit Revisione Pompa Acqua Honda Silver Wing 400/600 cc

APPLICABILITÀ

HONDA SILVER WING [FJS] 400 4T 06-08, SW-T [FJS] 400 4T 09-13, SILVER WING [FJS] 600 4T 01-10, SW-T [FJS] 600 4T 11-13

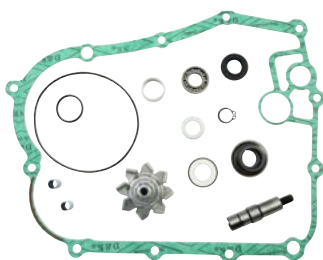

◀ cod. **AA00837**
Kit Revisione Pompa Acqua Kymco Xciting 400 cc

APPLICABILITÀ

KYMCO X CITING I 400 4T 15-15, X CITING I ABS 400 4T 14-15, XCITING I 400 4T 13-13



◀ cod. **AA00838**
Pompa Acqua Completa Yamaha YP 250/270 cc

APPLICABILITÀ

APRILIA LEONARDO 250 4T 99-04, LEONARDO ST 250 4T 01-01, LEONARDO 300 4T 02-04

MBK SKYLINER 250 4T 00-03, SKYLINER ABS 250 4T 03-03, KILIBRE 300 4T 03-06

BENELLI VELVET 250 4T 99-03

YAMAHA MAJESTY 250 4T 96-03, MAJESTY ABS 250 4T 03-03,

ITALJET JUPITER 250 4T 00-02

MALAGUTI MADISON S 250 4T 99-01, PASSWORD 250 4T 05-06, PASSWORD EU3 250 4T 07-08

MAJESTY DX 250 4T 98-99, X-CITY 250 4T 07-15, X-MAX 250 4T 05-16, X-MAX ABS 250 4T 14-15, VERSITY 300 4T 03-06

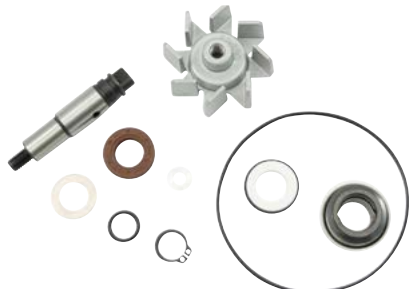

◀ cod. **AA00839**
Kit revisione pompa Acqua Bmw C 600 sport, C 650 sport/gt

APPLICABILITÀ

BMW BMW C 600 SPORT [K18] 650 4T 11-15, BMW C 650 GT 2016 [K19] 650 4T 16-16, BMW C 650 GT [K19] 650 4T 11-15, BMW C 650 SPORT 2016 [K18] 650 4T 16-16



◀ cod. **AA00840**
Kit revisione pompa acqua Kymco Xciting 500 cc

APPLICABILITÀ

KYMCO X CITING 500 4T 05-05, X CITING I 500 4T 06-08, X CITING I R 500 4T 07-08, X CITING R 500 4T 09-09



◀ cod. **AA00844**
Kit revisione pompa acqua Yamaha X-Max 300cc

APPLICABILITÀ

YAMAHA X-MAX 300 4T-4V 17-18, X-MAX ABS 300 4T-4V 19-20, X-MAX ABS IRON MAX 300 4T-4V 19-19, X-MAX ABS TECH MAX 300 4T-4V 20-20

NOVITÀ



◀ cod. **TG00100**
Kit Tagliando Piaggio Liberty 125 Eu3 '07/'15

APPLICABILITÀ

DERBI SONAR 4T 125 4T 09-11, SONAR 4T 150 4T 09-09

PIAGGIO LIBERTY 4T 125 4T 06-07, LIBERTY 4T EU3 125 4T 06-08, LIBERTY 4T EU3 DELIVERY - TNT 125 4T 08-15, LIBERTY 4T SPORT EU3 125 4T 06-08, LIBERTY SPORT 125 4T 06-06, LIBERTY 4T EU3 150 4T 08-08, LIBERTY 4T SPORT EU3 150 4T 08-08



◀ cod. **TG00101**
Kit Tagliando Piaggio Beverly 250 '04/'09

APPLICABILITÀ

PIAGGIO BEVERLY 250 4T 05-07, BEVERLY CRUISER 250 4T 07-09, BEVERLY EURO 3 MIC 250 4T 07-07, BEVERLY IE EU3 250 4T 06-08, BEVERLY RST 250 4T 04-05, BEVERLY SPORT 250 4T 06-08, BEVERLY TOURER EU3 250 4T 07-09, CARNABY 250 4T 08-09



◀ cod. **TG00102**
Kit Tagliando Piaggio Beverly 300 '09/'18

APPLICABILITÀ

APRILIA SPORT CITY CUBE 250 4T 08-12, SCARABEO LIGHT 300 4T 09-10, SPORT CITY STREET 300 4T-4V 12-12

PIAGGIO BEVERLY RST 4T 4V IE EU3 300 4T 10-16, BEVERLY TOURER EU3 300 4T 09-10, CARNABY CRUISER 300 4T 09-12

DERBI RAMBLA 300 4T 10-11



◀ cod. **TG00103**
Kit Tagliando Kymco Agility R16 125 '08/'12

APPLICABILITÀ

KYMCO AGILITY PLUS 125 4T 14-14, AGILITY PLUS E4 125 4T 16-16, AGILITY R16 125 4T 08-09, AGILITY R16 125 4T 12-12, PEOPLE 125 4T 99-00, PEOPLE EU2 125 4T 03-03, PEOPLE EU3 125 4T 07-08, PEOPLE EU3 125 4T 11-11, PEOPLE ONE E4 125 4T 16-16, PEOPLE ONE I 125 4T 13-13, PEOPLE ONE I DD 125 4T 15-15, PEOPLE S 125 4T 05-05, PEOPLE S DD EU3 125 4T 07-08, SUPER 8 125 4T 08-09, AGILITY R16 150 4T 08-09, PEOPLE 150 4T 99-00, PEOPLE EU2 150 4T 03-03



◀ cod. **TG00104**
Kit Tagliando Suzuki Burgman 400'07/'16

APPLICABILITÀ

SUZUKI AN BURGMAN K7/LO 400 4T 07-10, AN BURGMAN L1 400 4T 11-11, AN BURGMAN L2 400 4T 12-12, AN BURGMAN L3 400 4T 13-13, AN BURGMAN L4 400 4T 14-14, AN BURGMAN L5 400 4T 15-15, AN BURGMAN L6 400 4T 16-16



◀ cod. **TG00105**
Kit Tagliando Honda SH 125-150'01/'12

APPLICABILITÀ

HONDA SH 125 4T-2V 01-04, SH IE SCOOPIY 125 4T-2V 05-12, SH 150 4T-2V 01-04, SH IE SCOOPIY 150 4T 05-12



◀ cod. **TG00106**
Kit Tagliando Honda SH 300'06/'16

APPLICABILITÀ

HONDA SH IE SCOOPIY 300 4T-4V 07-16



◀ cod. **TG00107**
Kit Tagliando Yamaha T-Max 500'01/'07

APPLICABILITÀ

YAMAHA T-MAX 485 500 4T 09-11, T-MAX 485 ABS 500 4T 08-11, T-MAX 5GJ 500 4T 01-03, T-MAX 5VU 500 4T 04-08, T-MAX 5VU ABS 500 4T 05-07, T-MAX 5VU BLACK MAX 500 4T 06-06, T-MAX 5VU BLACK MAX - NIGHT MAX 500 4T 07-07



◀ cod. **TG00108**
Kit Tagliando Yamaha T-Max 530'12"/16

APPLICABILITÀ

YAMAHA T-MAX 59C 530 4T 12-16, T-MAX 59C ABS 530 4T 12-16, T-MAX 59C SP 530 4T 15-15, T-MAX 59C SP ABS 530 4T 15-16



◀ cod. **TG00109**
Kit Tagliando Yamaha X-Max 250'06"/16

APPLICABILITÀ

YAMAHA X-CITY 250 4T 07-15, X-MAX 250 4T 07-16, X-MAX ABS 250 4T 11-12, X-MAX ABS 250 4T 14-15, X-MAX BLACK 250 4T 09-09, X-MAX SPORT 250 4T 11-12



◀ cod. **TG00110**
Kit Tagliando Yamaha X-Max 125'06"/16

APPLICABILITÀ

YAMAHA X-CITY EU3 125 4T-4V 08-11, X-MAX R 125 4T-4V 06-16, X-MAX R ABS 125 4T-4V 11-11, X-MAX RA ABS 125 4T-4V 13-16



◀ cod. **TG00111**
Kit Tagliando Piaggio Mp3 125 ie'08/'11 - Vespa Gts Eu3 125'07/'12

APPLICABILITÀ

PIAGGIO MP3 125 4T 06-08, MP3 IBRIDO 125 4T 09-10, MP3 IE 125 4T 08-09, MP3 IE TOURING 125 4T 11-12, VESPA GRANTURISMO 125 4T 03-07, VESPA GRANTURISMO EU3 125 4T 06-07, VESPA GTS EU3 125 4T 07-12, VESPA GTV 125 4T 06-08, VESPA GTV 4T NAVY EU3 125 4T 08-08, X-EVO 125 4T 07-16, X8 PREMIUM EU2 125 4T 06-06, X8 PREMIUM EU3 125 4T 06-07, X9 EVOLUTION EU3 125 4T 07-07



◀ cod. **TG00112**
Kit Tagliando Piaggio Mp3 500 Lt Sport Business'11/'13

APPLICABILITÀ

GILERA FUOCO 4T-4V IE E3 LT 500 4T 13-14, FUOCO IE EU3 500 4T 07-13
PIAGGIO BEVERLY CRUISER 500 4T 07-12, MP3 LT SPORT/BUSINESS 500 4T 11-13, MP3 RL SPORT-BUSINESS 500 4T 11-12, X10 4T-4V IE EU3 500 4T 12-14



◀ cod. **TG00113**
Kit Tagliando Honda PCX 125cc 10-11

APPLICABILITÀ

HONDA PCX 125 4T-2V 10-11

NOVITÀ



◀ cod. **TG00114**
Kit Tagliando Honda PCX 125cc 12-14

APPLICABILITÀ

HONDA PCX 125 4T-2V 12-14

NOVITÀ



◀ cod. **TG00115**
Kit Tagliando Honda PCX 125cc 15-18

APPLICABILITÀ

HONDA PCX 125 4T-2V 15-18

NOVITÀ



◀ cod. **TG00118**
Kit Tagliando Suzuki Burgman 125 Dal 2013

APPLICABILITÀ

SUZUKI UH BURGMAN K7/LO 125 4T 07-10, UH BURGMAN L1 125 4T 11-11, UH BURGMAN L3 125 4T 13-13, UH BURGMAN L4 125 4T 14-14, UH BURGMAN L6 125 4T 16-16, UH BURGMAN L7 125 4T 17-17, UH BURGMAN L8 125 4T 18-18, UH BURGMAN L9 125 4T 19-19



◀ cod. **TG00119**
Kit Tagliando Suzuki Burgman 650 '06/'18

APPLICABILITÀ

SUZUKI AN BURGMAN K3-K5 650 4T 03-05, AN BURGMAN K6-LO 650 4T 06-10, AN BURGMAN L1 650 4T 11-11, AN BURGMAN L2 650 4T 12-12, AN BURGMAN L3 650 4T 13-13, AN BURGMAN L4 650 4T 14-14, AN BURGMAN L5 650 4T 15-15, AN BURGMAN L6 650 4T 16-16, AN650Z BURGMAN 650 4T 18-18



KIT	RICAMBI		
	CATENA	CORONA	PIGNONE

APRILIA	SHIVER	750	4T	07 > 08	PEK1101G	PEK525SROZ2110	P436344C45	P21501618NC
	MANA	850	4T	07 > 12	PEK1102G	PEK525SROZ2104	P444740C45	P21481818NC
	RS4	125	4T	13 > 13	PEK1122	PEK428DEH136	P460660C45	P22231318NC
	RS4	125	4T	15 > 15	PEK1126	PEK428DEH136	P460660C45	P22891318NC
	RED ROSE	50	2T	92 > 01	PEK131	PEK415SH130	P356446F	P5991218NC
	RX	50	2T	96 > 98	PEK142	PEK415SH126	P356551F	P6001218NC
	RS REPLICCA	125	2T	93 > 02	PEK145	PEK520110	P71439C45	P4061718NC
	RS REPLICCA	125	2T	93 > 02	PEK145-Z40-16			
	PEGASO	650	4T	91 > 97	PEK164G	PEK520SR06110	P355247C45	P4021618NC
	ETV CAPO NORD	1000	4T	03 > 03	PEK166G	PEK525MVXZ2112	P442745C45	P20781718NC
	RS	125	2T	06 > 06	PEK187	PEK520110	P439640C45	P4061718NC
	RS	125	2T	06 > 06	PEK187-Z40-16			
	RS	50	2T	06 > 06	PEK189	PEK420SR132	P441253F	P21531218NC
BMW	F800GS	800		08 > 08	PEK1200G	PEK525SROZ2116	P455042C45	P20781618NC
	F800GS	800		10 > 10	PEK1214G	PEK525SROZ2116	P461342C45	P20781618NC
	F800R	800		09 > 14	PEK1261G	PEK525SROZ2120	P461347C45	P2078M2018NC
	F GS	650		04 > 04	PEK182G	PEK520SR06112	P355247C45	P4021618NC
CAGIVA	SST	125		82 > 85	PEK205	PEK428DEH136	P70462F	P4161418NC
	ELEFANT	125		85 > 86	PEK206	PEK428DEH124	P48645C45	P7101618NC
DERBI	GP1	50		05 > 08	PEK1290	PEK420H134	P441245F	P21071218NC
DERBI	GPR R	50		05 > 08	PEK1295	PEK420H134	P441253F	P21071218NC
	GPR 4T	125		11 > 11	PEK2292	PEK428H130	P460749C45	P21181418NC
DUCATI	696 MONSTER	696		09 > 09	PEK1310G	PEK520MVXZ2108	P102745C45	P490BL1518N
	MULTISTRADA	1200		10 > 12	PEK1337G	PEK530ZVX3110	P464340LD	P22541518NC
	MONSTER	600		95 > 99	PEK315G	PEK520SRX2102	P102743C45	P4901518NC
	MONSTER	900		94 > 99	PEK319G	PEK520MVXZ298	P102739C45	P4901518NC
	MONSTER	600		00 > 01	PEK336G	PEK520SRX2102	P102746C45	P4901518NC

KIT TRASMISSIONE

MOTORPARTS
YOUR QUALITY SUPPLIER

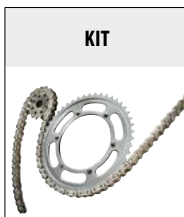

RICAMBI			
KIT	CATENA	CORONA	PIGNONE

DUCATI	MONSTER	620		02 > 03	PEK358G	PEK520MVXZ2106	P102746C45	P490BL1518N
	MONSTER I.E.	620		00 > 00	PEK375G	PEK520MVXZ2106	P102748C45	P490BL1518N
FANTIC	CABALLERO MOTARD	125		08 > 11	PEK1354	PEK428DEH140	P450254L5	P21821418NC
GILERA	GP	800		07 > 11	PEK453G	PEK525SROZ2104	P455747C45	P21962218NC
HM	CRE SIX, BAIA, DERAPAGE	50		04 > 06	PEK1549	PEK428DEH140	P441362L	P2064M1418N
	CRE SIX, BAIA, DERAPAGE	50		04 > 06	PEK2521	PEK428DEH140	P441362L	P2064M1218N
	CRE ENDURO	50		02 > 02	PEK580		P439056F	P20641218NC
	CRE SIX, BAIA, DERAPAGE	50		02 > 02	PEK581	PEK428DEH140	P439056F	P20641318NC
HONDA	VT C SHADOW	125		02 > 02	PEK1516	PEK520114	P466841C45	P2791418NC
	XL LM-F/RM-G	600		85 > 88	PEK1536G	PEK520SRX2106	P24541C45	P2811518NC
	XL V TRANSALP	650		00 > 02	PEK1540G	PEK525SROZ2118	P30048C45	P3461518NC
	CB HORNET	900		02 > 03	PEK1544G	PEK530SROZ2114	P40843C45	P3471618NC
	XL V VARADERO	125		02 > 02	PEK1552	PEK520SR110	P466844C45	P2791418NC
	CBR RR	600		03 > 06	PEK1557G	PEK525SROZ2114	P440542C45	P20681618NC
	CBF N(S) (ABS)	600		04 > 04	PEK1574G	PEK525SROZ2116	P435743C45	P20731518NC
	CB HORNET	600		07 > 09	PEK2507G	PEK525SROZ2118	P435743C45	P20681618NC
	XL V TRANSALP	700		08 > 08	PEK2511G	PEK525MVXZ2118	P30047C45	P3461518NC
	CB R (ABS)	1000		08 > 09	PEK2514G	PEK530MVXZ2116	P456244C45	P3471618NC
	INTEGRA	700		12 > 13	PEK2538G	PEK520SRX2112	P438439C45	P20421618NC
	INTEGRA	700		12 > 13	PEK2538GOM			
	CB F,X, ABS, CBR R	500		13 > 14	PEK2541G	PEK520SRO6112	P438441C45	P20421518NC
	NCX	750		14 > 15	PEK2544G	PEK520SRX2114	P438443C45	P20421718NC
	NCX	750		14 > 15	PEK2544GOM			
	NC D INTEGRA	750		15 > 15	PEK2545G	PEK520SRX2114	P438439C45	P20421718NC
	CRF 1000 L AFRICA TWIN ABS	1000		17 > 17	PEK2550G	PEK525MVXZ2124	P435042C45	P20681618NC
	CTX N	700		14 > 14	PEK2620GOM			
	NC D INTEGRA	750		15 > 15	PEK3144GOM			



KIT	RICAMBI		
	CATENA	CORONA	PIGNONE

HONDA	XL VK TRANSALP	600		89 > 00	PEK517G	PEK525SROZ2118	P30047C45	P3461518NC
	VT C SHADOW	600		90 > 02	PEK539G	PEK525SROZ2120	P435044C45	P3461618NC
	XRV AFRICA TWIN	750		93 > 01	PEK541G	PEK525SROZ2124	P435045C45	P3481618NC
	CA REBEL	125		95 > 99	PEK548	PEK520114	P27939C45	P3291318NC
	NX S	650		95 > 00	PEK567G	PEK520SR06110	P23646C45	P3451518NC
	CB S	500		98 > 00	PEK574G	PEK525SROZ2108	P435040C45	P20411518NC
	CB HORNET	600		97 > 04	PEK575G	PEK525SROZ2110	P435742C45	P20731518NC
HUSQVARNA	VT C SHADOW	750		97 > 09	PEK577G	PEK525SROZ2122	P435741C45	P22681718NC
	SM	125		10 > 12	PEK1993	PEK428DEH136	P459054C45	P21821418NC
HYOSUNG	SM S	610		09 > 09	PEK2904G	PEK520SR06112	P82045C45	P7271518NC
	GV AQUILA	250		04 > 05	PEK2931	PEK520SR116	P454046C45	P21931418NC
KAWASAKI	ZR-7 ZR-7S	750		99 > 01	PEK1640G	PEK525SROZ2108	P530138C45	P5821618NC
	Z /S-ZR-ABS	750		12 > 12	PEK1656G	PEK520MVXZ2112	P47843C45	P21191518NC
	NINJA ZX-6R	600		05 > 06	PEK1688G	PEK520MVXZ2112	P47843C45	P2093M1518N
	ER-6N	650		06 > 06	PEK1695G	PEK520SR06114	P47846C45	P5651518NC
KTM	KLE VERSYS	650		07 > 09	PEK2602G	PEK520SR06114	P47846C45	P5651518NC
	KLE VERSYS	650		07 > 09	PEK3106GOM			
MALAGUTI	DUKE	125		14 > 15	PEK2979	PEK520SR120	P467545C45	P22471418NC
	FIFTY TOP	50		90 > 99	PEK1151	PEK415SH110	P334F	P1471318NC
RIEJU	CNK DRAGON	50		05 > 08	PEK1166	PEK420H134	P453148F	P600M1118NC
	MRX	50		05 > 05	PEK2682	PEK420H134	P440252F	P600M1118NC
	SMX E.S./K.S.	50		07 > 07	PEK2685	PEK420H134	P455152F	P600M1118NC
SUZUKI	GS-E X	500		99 > 04	PEK1759G	PEK520SR06110	P79539C45	P5231618NC
SUZUKI	GSF-Y BANDIT	600		00 > 05	PEK1760G	PEK530SROZ2112	P82447C45	P5661518NC
SUZUKI	DL V-STROM	1000		02 > 03	PEK1761G	PEK525MVXZ2112	P439842C45	P5641718NC
SUZUKI	DL V-STROM	650		04 > 04	PEK1771G	PEK525SROZ2116	P439847C45	P5641518NC
SUZUKI	GSX-R	600		06 > 09	PEK1779G	PEK525SROZ2114	P439843C45	P5641618NC



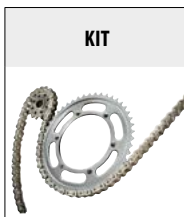

KIT TRASMISSIONE

MOTORPARTS
YOUR QUALITY SUPPLIER

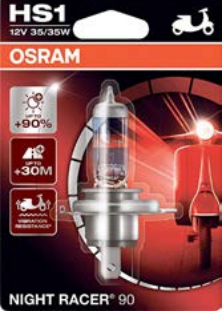

RICAMBI			
KIT	CATENA	CORONA	PIGNONE

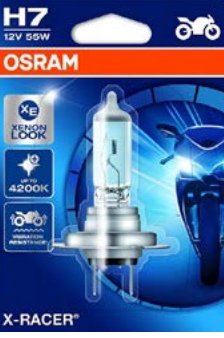
SUZUKI	Model	Capacity	Year	Kit	Catena	Corona	Pignone
	GSR	600	06 > 06	PEK1783G	PEK525SR0Z2114	P439848C45	P5641618NC
SFV GLADIUS	650	09 > 09	PEK2704G	PEK520SR06112	P79546C45	P5651518NC	
DL V-STROM-ABS	650	07 > 09	PEK2713G	PEK525SR0Z2118	P439847C45	P5641518NC	
VZ800 MARAUDER	800	97 > 98	PEK744G	PEK530SR0Z2116	P82448C45	P5661518NC	
SV	650	99 > 02	PEK790G	PEK525SR0Z2108	P82844C45	P5641518NC	
SV S	650	99 > 00	PEK791G	PEK525SR0Z2110	P82845C45	P5641518NC	
YAMAHA	TDM (ABS)	900	02 > 02	PEK1874G	PEK525MVXZ2118	P30042C45	P20911618NC
	FZ6 FAZER S2 ABS	600	04 > 04	PEK1885G	PEK530SR0Z2118	P24146C45	P5801618NC
XT-R	660	04 > 14	PEK1898G	PEK520SRX2110	P86645C45	P3451518NC	
MT-03	660	06 > 12	PEK1983G	PEK520SRX2112	P86647C45	P3451518NC	
YZF-R IE	125	08 > 10	PEK2805		P451348C45	P21821418NC	
TRICKER	250	06 > 08	PEK2817	PEK428DEH124	P456945C45	P21491518NC	
WR-X/R-Y-E	125	09 > 09	PEK2818	PEK428DEH134	P84453C45	P21821418NC	
MT-09	850	15 > 15	PEK2849G	PEK525MVXZ2110	P438545C45	P20911618NC	
XT	600	87 > 94	PEK811G	PEK520SR06104	P85739C45	P4411518NC	
XT E	600	90 > 00	PEK812G	PEK520SR06106	P85745C45	P4411518NC	
XT Z SUPER TENERE	750	89 > 90	PEK819G	PEK520SRX2112	P86646C45	P5851618NC	

		PART NUMBER	DESCRIZIONE	ECE	V	W	ATTACCO	Q.TÀ
 <p>NIGHT RACER® 110 Lampade Moto Più 110% di luce e 20% più bianca</p>		64193NR1-01B	NIGHT RACER® 110 H4 12V BLI1	H4	12	60/55	P43t	1
		64193NR1-02B	NIGHT RACER® 110 H4 12V BLI2	H4	12	60/55	P43t	2
		64210NR1-01B	NIGHT RACER® 110 H7 12V BLI1	H7	12	55	PX26d	1
		64210NR1-02B	NIGHT RACER® 110 H7 12V BLI2	H7	12	55	PX26d	2
		64212NR1-01B	NIGHT RACER® 110 H8 12V BLI1	H8	12	35	PGJ19-1	1
		64211NR1-01B	NIGHT RACER® 110 H11 12V BLI1	H11	12	55	PGJ19-2	1
 <p>NIGHT RACER® 90 Lampade Moto Più 90% di luce e 20% più bianca</p>		64185NR9-01B	NIGHT RACER® 90 HS1 12V BLI1	HS1	12	35/35	PX43t	1
 <p>NIGHT RACER® 50 Lampade Moto Più 50% di luce</p>		64193NR5-01B	NIGHT RACER® 50 H4 12V BLI1	H4	12	60/55	P43t	1
		64210NR5-01B	NIGHT RACER® 50 H7 12V BLI1	H7	12	55	PX26d	1
		64211NR5-01B	NIGHT RACER® 50 H11 12V BLI1	H11	12	55	PGJ19-2	1
		64185NR5-01B	NIGHT RACER® 50 HS1 12V BLI1	HS1	12	35/35	PX43t	1
		64185NR5	NIGHT RACER® 50 HS1 12V	HS1	12	35/35	PX43t	1
 <p>X-RACER® Lampade Moto Xenon Look Più 20% di luce fino a 4200K</p>		64193XR-01B	X-RACER® H4 12V BLI1	H4	12	60/55	P43t	1
		64193XR-02B	X-RACER® H4 12V BLI2	H4	12	60/55	P43t	2
		64210XR-01B	X-RACER® H7 12V BLI1	H7	12	55	PX26d	1
		64210XR-02B	X-RACER® H7 12V BLI2	H7	12	55	PX26d	2
		64212XR-01B	X-RACER® H8 12V BLI1	H8	12	35	PGJ19-1	1
		64211XR-01B	X-RACER® H11 12V BLI1	H11	12	55	PGJ19-2	1
		64185XR-01B	X-RACER® HS1 12V BLI1	HS1	12	35/35	PX43t	1
		64327XR-01B	X-RACER® S2 12V BLI1	S2	12	35/35	BA20d	1
 <p>ORIGINAL LINE LAMPADRE MOTO OEM QUALITY</p>		64193MC	ORIGINAL MOTO H4 12V	H4	12	60/55	P43t	1
		64210MC	ORIGINAL MOTO H7 12V	H7	12	55	PX26d	1
		64326	ORIGINAL S1 12V	S1	12	25/25	BA20d	1
		64327	ORIGINAL S2 12V	S2	12	35/35	BA20d	1
		64327-01B	ORIGINAL S2 12V BLI1	S2	12	35/35	BA20d	1
		64185	ORIGINAL HS1 12V	HS1	12	35/35	PX43t	1<<

Kit Led Headlight - Led headlight kit

HEADLIGHT SIMPLY | 12 Volt | 15W | 1500 Lumen | 6500° K CCT Operating Temperature -40° + 80°



CODE	CHIP	RETROFIT	Q.TÀ
LP417577	LP CSP	H7	

HEADLIGHT K2 | 9-32 Volt | 30 W | 5000 Lumen | 6500° K CCT Operating Temperature -45° + 115°



CODE	CHIP	RETROFIT	Q.TÀ
LP4172841	PHILIPS ZES	HS1 - H4	



4172871	PHILIPS ZES	HS1 - H4	
---------	-------------	----------	--

HEADLIGHT BASIC PLUS | 12 Volt | 28 W | 3200 Lumen | 6500° K CCT Operating Temperature -40° + 80°



CODE	CHIP	RETROFIT	Q.TÀ
	FLIP COB	H1 - H4 - H7 - H8/9/11	

HEADLIGHT B | 12-24 Volt | 36W | 8000 Lumen | 6500° K CCT Operating Temperature -40° +80°



CODE	CHIP	RETROFIT	Q.TÀ
LP39362	TYPE COB	H1	1
LP39125	TYPE COB	H7	1
LP39124	TYPE COB	H4	1
LP39126	TYPE COB	H8 - H9 - H11	1

HEADLIGHT TOKYO | 12-24 Volt | 42 W | 8000 Lumen | 6500° K CCT Operating Temperature -40° +80°



CODE	CHIP	RETROFIT	Q.TÀ
LP39627	TYPE CREE XHP50	H1	1
LP39630	TYPE CREE XHP50	H3	1
LP39614	TYPE CREE XHP50	H4	1
LP39659	TYPE CREE XHP50	H7	1
LP39288	LP TYPE CREE XHP50	H8 - H9 - H11	1
LP39616	TYPE CREE XHP50	HB3 - 9005	1
LP39619	TYPE CREE XHP50	HB4 - 9006	1

KIT PREMIUM STATIC | 12-24 Volt | 25 W | 4000Lumen | 6500° K CCT Operating Temperature -40° +80°



CODE	CHIP	RETROFIT	Q.TÀ
LP39665	TYPE ZES	H1	1
LP39663	TYPE ZES	H4	1
LP39667	TYPE ZES	H7	1
LP39661	TYPE ZES	H8 - H9 - H11	1

KIT PREMIUM AVIO | 12-24 Volt | 25 W | 4000Lumen | 6500° K CCT Operating Temperature -40° +80°



CODE	CHIP	RETROFIT	Q.TÀ
LP39689	TYPE ZES	H1	1
LP39093	TYPE ZES	H3	1
LP39688	TYPE ZES	H4	1
LP39287	TYPE ZES	H7	1
LP39669	TYPE ZES	H8 - H9 - H11	1
LP39679	TYPE ZES	HB3 - 9005	1
LP39681	TYPE ZES	HB4 - 9006	1

KIT PREMIUM AVIO 2 | 12-24 Volt | 30 W | 6000 Lumen | 6500° K CCT Operating Temperature -40° +80°

	CODE	CHIP	RETROFIT	Q.TÀ
	LP39879	TYPE ZES 2	H1	1
	LP39883	TYPE ZES 2	H3	1
	LP39885	TYPE ZES 2	H4	1
	LP39891	TYPE ZES 2	H7	1
	LP39899	TYPE ZES 2	H8 - H9 - H11	1
	LP39887	TYPE ZES 2	HB3 - 9005	1
	LP39889	TYPE ZES 2	HB4 - 9006	1

KIT NEW FASHION | 8-32 Volt | 12W | 1050Lumen | 6500° K CCT Operating Temperature -40° +80°







	CODE	CHIP	RETROFIT	Q.TÀ
	LP39558	TYPE COB	BA20d	1

Lampade LED - Led Lamps







LED SMD -COB | 12 Volt

	CODE	VOLT	LED	BASE	RETROFIT	NOTE	Q.TÀ
	LP39204	12	Led Bianco / white	W2,1X9,5d	T10		2
	LP39121	12	Led Bianco / white	BA9s	T4W		2
	LP39537	12	1 SMD EPISTAR	BA9s	R5W		2

LED SMD -CANBUS | 12 Volt





	CODE	VOLT	LED	BASE	RETROFIT	NOTE	Q.TÀ
	LP39205	12	1 SMD EPISTAR	W2,1X9,5d	T10		2
	LP39206	12	8 SMD EPISTAR	W2,1X9,5d	T10	BMW, Mini...	2
	LP39469	12	SMD EPISTAR	W2,1X9,5d	T10	AMBER	2
	LP39421	12	5 SMD EPISTAR	BA9s	R5W		2
	LP39181	12	8 SMD EPISTAR	BAX9s	H6W		2
	LP39212	12	4 SMD EPISTAR	SV8,5-8	Festoon	12x38 mm	2
	LP39213	12	3 SMD EPISTAR	SV8,5-8	Festoon	12x36 mm	2

LAMPADE TOPLIGHT

	LP39215	12	6 SMD EPISTAR	SV8,5-8	Festoon	16x36 mm	2
	LP39216	12	27 SMD EPISTAR	BA15s	P21/W	1 LUCE / LIGHT 1156	2
	LP39217	12	27 SMD EPISTAR	BAY15d	P21/5W	2 LUCI / LIGHTS 1157	2
	LP39218	12	1 LUCE / LIGHT EPISTAR	W3X16d	T20W21W		2
	LP39568	12	2 LUCI / LIGHTS EPISTAR	W3X16d	T20 W21/5W		2
	LP41368	12		BA15S	P21W	AMBER	2
	LP41369	12		BAU15S	P21W	AMBER	2
	LP41375	12		BAY15d	P21W	AMBER	3







Lampade Energy White

LAMPADE PER PROIETTORI ENERGY WHITE 4000 K - LAMPS

	CODE	VOLT	WATT	BASE	ECE	NOTE	Q.TÀ
	LP39060	12	55	P14,5s	H1		2
	LP39191	12	55	PK22s	H3		2
	LP39061	12	60/55	P43t	H4		2
	LP39062	12	55	PX26d	H7		2

LAMPADE PER PROIETTORI ENERGY WHITE 4000 K - LAMPS







	CODE	VOLT	WATT	BASE	ECE	NOTE	Q.TÀ
	LP39164	12	65	P20d	HB3	9005	2
	LP39165	12	55	P22d	HB4	9006	2
	LP39183	12	35	PGJ19-1	H8		2
	LP39063	12	55	PGJ19-2	H11		2
	LP39344	12	35/30	P23t	HS5		1

LAMPADE AUSILIARIE ENERGY WHITE · AUXILIARY BULBS							Q.TÀ
	CODE	VOLT	WATT	BASE	ECE	NOTE	
	LP39139	12	5	W2,1X9,5d	W5W	4000K T10 PAINTED	10
	LP39286	12	5	W2,1X9,5d	W5W	5000K T10 ORIGINAL GLASS	2
	LP39402	12	5	SW2,1X9,5d	W5W	T10 - 4000K HALOGEN	2
	LP39348	12	21/5	W3X16q	T20	5000K	2
	LP39396	12	21	W3X16d	T20	5000K	2
	LP39159	12	21/5	W3X16q	T20	6000K CRYSTAL CROMO	2
	LP39380	12	10	BA9s	H10W	4000K	2
	LP39129	12	6	BAX9s	H6W	4000K	1
	LP39174	12	5	SV8,5	C5W	6000K 11x38 mm CRYSTAL CROMO	2
	LP39176	12	5	SV8,5	C5W	4000K 11X38	2







Lampade Standard

LAMPADE PER PROIETTORI STANDARD - STANDARD LAMPS | 12Volt

	CODE	VOLT	WATT	BASE	ECE	NOTE	Q.TÀ
	LP39042	12	55	PX26d	H7	PREMIUM	1
	LP39001	12	60/55	P43t	H4		1
	LP39008	12	55	P14,5s	H1		1
	LP39023	12	55	PK22s	H3		1
	LP39025	12	55	PGJ19-2	H11		1
	LP39026	12	65	P20d	HB3	9005	1
	LP39031	12	55	P22d	HB4	9006	1

LAMPADE PER PROIETTORI STANDARD - STANDARD LAMPS | 6-12 Volt

	CODE	VOLT	WATT	BASE	ECE	NOTE	Q.TÀ
	LP39343	12	35/30	P23t	HS5		1
	LP39028	12	35	PGJ19-1	H8		1
	LP39349	12	35/35	BA20d	S2		1
	LP39350	12	45/40	BA20d			1
	LP39555	6	25/25	BA20d			1
	LP39353	12	35/35	PX43t	HS1		1
	LP39368	12	15	P26s	S3		10
	LP39556	6	15	P26s	S3		10

LAMPADE AUSILIARIE - AUXILIARY BULBS 12 Volt							
	CODE	VOLT	WATT	BASE	ECE	NOTE	Q.TÀ
	LP39003	12	21/5	BAY15d	P21/5W		10
	LP39004	12	21	BA15s	P21W		10
	LP39345	12	21	BA15s	PY21W	AMBER PAINTED	10
	LP39014	12	21	BAU15s	PY21W	AMBER PAINTED	10
	LP39357	12	21	BA15s	PR21W	ROSSA RED	10
	LP39560	12	21/5	BAY15d	PR21/5W	ROSSA RED	2
	LP39005	12	5	BA15s	R5W		10
	LP39011	12	10	BA15s	R10W		10
	LP39111	12	2	BA9s	T2W		10
	LP39012	12	4	BA9s	T4W		10
	LP39007	12	5	SV8,5	C5W	10,5x38 mm	10
	LP39096	12	3	SV7	C3W	7,5x30 mm	10
	LP39013	12	3	W2,1X9,5d	W3W	T10	10
	LP39002	12	5	W2,1X9,5d	W5W	T10	10
	LP39108	12	5	W2,1X9,5d	WY5W	T10 - AMBER	10
	LP39018	12	16	W2,1X9,5d	W16W	T15	10
	LP39019	12	21/5	W3X16q	W21/5W	T20	10
	LP39020	12	21	W3X16d	W21W	T20	10
	LP39138	12	21	W3X16d	WY21W	T20 - AMBER painted	10

LAMPADE TOPLIGHT

	LP39192	12	21/5	W3X16q	WY5/21W	T20 - ROSSA RED	1
	LP39015	12	6	BAX9s	H6W		10
	LP39351	12	10	BA9s	H10W		1
	LP39022	12	21	BAY9s	H21W		1

Fari da lavoro - Led Worklights

FARI DA LAVORO A LED - LED WORKLIGHTS | 10/30 Volt

	CODE	DESCRIZIONE / DESCRIPTION	LED	WATT	LUMEN	Q.TÀ
	LP39127	FARETTO UNIVERSALE A LED IP67 LENTE IN PC / LED WORK LIGHT IP 67 PC LENS	9 LED EPISTAR	27	1750	1
	LP39222	FARETTO UNIVERSALE A LED TONDO IP67 LENTE IN PC / LED WORK LIGHT IP 67 PC LENS	9 LED EPISTAR	27	1750	1
	LP39266	BASE MAGNETICA UNIVERSALE Max 50kg Max 120 km/h / MAGNETIC BASE				1

LAMPADE DA OFFICINA - LAMPS FOR WORKSHOPS

	CODE	DESCRIZIONE / DESCRIPTION	Q.TÀ
	LP39267	LAMPADA DA OFFICINA / INSPECTION LAMP SMARTLite	1
	LP39268	PENNA LUMINOSA / LIGHT PEN SMARTLite Mini	1
	LP39269	ESPOSITORE / DISPLAY SMARTLite Mini	10

LAMPADE DA LAVORO - LAMPS FOR WORKLIGHTS | 3.7 Volt

	CODE	DESCRIZIONE / DESCRIPTION	LED	WATT	LUMEN	Q.TÀ
	LP39927	SMARTLite POCKET	2W COB + 1W Torcia	Li-ion 14500 type Li-ion 3.7V 800mAh	220 Lumen per la lampada 60 Lumen per la torcia	
	LP39929	SMARTLite BASIC	2W COB	Li-ion 18650 type Li-ion 3.7V 2200mAh	220	
	LP39932	SMARTLite HEAD	3W COB	Li-Poly 3.7V 1400mAh	2 ore a 260 Lumen 4 ore a 120 Lumen	



◀ **cod. MC12002**
Membrana carburatore per scooter Piaggio 125 cc

RIFERIMENTO ORIGINALE

Piaggio	CM140501
---------	----------

APPLICABILITÀ

APRILIA MOJITO 125 4T 03-08, MOJITO 150 4T 03-07
DERBI BOULEVARD EU2 125 4T 04-07, BOULEVARD 150 4T 03-04

PIAGGIO BEVERLY 125 4T 01-03, HEXAGON GTX 125 4T 00-00, LIBERTY 125 4T 98-02, SKYPPER 4T 125 4T 00-02, VESPA ET4 125 4T 96-02, X9 125 4T 01-02, ZIP 125 4T 00-02, LIBERTY 150 4T 01-02, SKYPPER 4T 150 4T 00-02, VESPA ET4 150 4T 99-02, HEXAGON GTX 180 4T 00-00



◀ **cod. MC12004**
Membrana Carburatore Honda SH 125/150 cc

RIFERIMENTO ORIGINALE

Honda	16111-KFG-911
-------	---------------

APPLICABILITÀ

HONDA @ [NES] 125 4T 00-06, DYLAN [SES] 125 4T 02-04, SH 125 4T-2V 01-04, @ [NES] 150 4T 00-06, DYLAN [SES] 150 4T 02-04, SH 150 4T-2V 01-04



◀ **cod. MC12009**
Membrana carburatore KYMCO AGILITY 50 cc 4T

RIFERIMENTO ORIGINALE

Kymco	00105115
-------	----------

APPLICABILITÀ

KYMCO AGILITY 4T CARRY 50 4T 11-11, AGILITY 4T R10 50 4T 06-08, AGILITY 4T R12 50 4T 07-08, AGILITY PLUS 4T 50 4T 14-14, AGILITY R12 50 4T 05-05, AGILITY R16 50 4T 08-09, AGILITY R16 50 4T 12-12, AGILITY RS 50 4T 09-09, DINK 50 4T 50 4T 07-07, LIKE 50 4T 09-09, SUPER 8 4T 50 4T 07-07, SUPER 8 4T 50 4T 09-09, SUPER 8 4T 50 4T 13-13



◀ **cod. MC12100**
Membrana Carburatore Adattabile a Yamaha Majesty 125-150 cc '98-'02

RIFERIMENTO ORIGINALE

Honda	5DS1434A1000
-------	--------------

APPLICABILITÀ

BENELLI VELVET 125 4T 99-01, VELVET 150 4T 99-01
ITALJET JUPITER 125 4T 01-02, MILLENIUM 125 4T 00-02, JUPITER 150 4T 01-02, MILLENIUM 150 4T 00-02
MALAGUTI MADISON 125 4T 99-01, MADISON R RESTYLING 125 4T 02-02, PHANTOM MAX 125 4T 03-03, MADISON T 150 4T 99-01

MBK DOODO 125 4T 00-00, SKYLINER 125 4T 98-02, THUNDER 125 4T 01-02, DOODO 150 4T 01-02, THUNDER 150 4T 01-02
YAMAHA MAJESTY 125 4T 98-00, MAJESTY (5NR1) 125 4T 01-01, MAJESTY (5NR8) 125 4T 02-02, MAXSTER 125 4T 01-02, TEO'S 125 4T 00-00, MAJESTY 150 4T 00-00, MAJESTY (5NS1) 150 4T 01-01, MAJESTY (5NS6) 150 4T 02-02, MAXSTER 150 4T 01-02, TEO'S 150 4T 01-02



◀ cod. MC12101

Membrana Carburatore adattabile a scooter Minarelli/Yamaha 250/300 cc

RIFERIMENTO ORIGINALE

Yamaha	4HC143400100
--------	--------------

APPLICABILITÀ

APRILIA	LEONARDO 250 4T 99-04, LEONARDO ST 250 4T 01-01, LEONARDO 300 4T 02-04	MBK	SKYLINER E 125 4T 03-03, SKYLINER E 180 4T 03-03, SKYLINER 250 4T 00-03, SKYLINER ABS 250 4T 03-03, KILIBRE 300 4T 03-06
BENELLI	VELVET 250 4T 99-03	YAMAHA	MAJESTY E 125 4T 03-09, MAJESTY E 180 4T 03-06, MAJESTY 250 4T 96-03, MAJESTY ABS 250 4T 03-03, MAJESTY DX 250 4T 98-99, VERSITY 300 4T 03-06
ITALJET	JUPITER 250 4T 00-02		
MALAGUTI	MADISON R RESTYLING EU2 125 4T 03-04, MADISON S 250 4T 99-01		



◀ cod. MC12103

Membrana Carburatore adattabile a Kymco Agility 125/150 cc

RIFERIMENTO ORIGINALE

Kymco	00105036
-------	----------

APPLICABILITÀ

KYMCO	AGILITY 125 4T 06-06, AGILITY R16 125 4T 08-09, DINK EU3 125 4T 06-07, LIKE 125 4T 09-09, MOVIE EU3 125 4T 06-07, MOVIE XL EU2 125 4T 03-04, PEOPLE EU2 125 4T 03-03, PEOPLE EU3 125 4T 07-08, PEOPLE EU3 125 4T 11-11, PEOPLE S 125 4T 05-05, PEOPLE S DD EU3 125 4T 07-08, SUPER 8 125 4T 08-08, AGILITY R16 150 4T 08-09, MOVIE EU3 150 4T 06-07, MOVIE XL EU2 150 4T 03-04, PEOPLE EU2 150 4T 03-03, LIKE LX 200 4T 12-12, PEOPLE S 200 4T 05-05
--------------	--



◀ cod. MC12104

Membrana Carburatore adattabile a Honda SH 125/150 cc

RIFERIMENTO ORIGINALE

Honda	16111-KGF-911
-------	---------------

APPLICABILITÀ

HONDA	@ [NES] 125 4T 00-06, DYLAN [SES] 125 4T 02-04, SH 125 4T-2V 01-04, @ [NES] 150 4T 00-06, DYLAN [SES] 150 4T 02-04, SH 150 4T-2V 01-04
--------------	--



◀ cod. MC12105

Membrana carburatore adattabile a scooter Sym Symphony 125/150 cc

RIFERIMENTO ORIGINALE

Sym	1614227A000
-----	-------------

APPLICABILITÀ

SYM	SYMPHONY S 125 4T 12-14, SYMPHONY SR 125 4T 12-12, SYMPHONY S 150 4T 12-14, SYMPHONY SR 150 4T 12-12
------------	--



cod. MC12106

Membrana carburatore adattabile scooter Aprilia scarabeo 125 cc

RIFERIMENTO ORIGINALE

Aprilia	AP8575049	Piaggio	CM140301
---------	-----------	---------	----------

APPLICABILITÀ

<p>APRILIA ATLANTIC 125 4T 03-05, ATLANTIC EU3 125 4T 06-08, ATLANTIC EU3 125 4T 10-12, SCARABEO 125 4T 04-06, SCARABEO EU3 125 4T 06-07, SPORT CITY 125 4T 04-06, SPORT CITY CUBE 125 4T 08-10, SPORT CITY EU3 125 4T 06-08, SPORT CITY STREET 125 4T 12-12</p> <p>DERBI GP1 EU 2 125 4T 06-06, GP1 LOW SEAT EU3 125 4T 07-08, RAMBLA 125 4T 08-09, RAMBLA EU3 2VER 125 4T 08-08</p> <p>GILERA NEXUS EU3 125 4T 07-08, RUNNER 4T ST EU3 125 4T 08-16, RUNNER VX 125 4T 05-06, RUNNER VX 4T EU3 125 4T 06-07, RUNNER VX RACE 125 4T 06-06, RUNNER VX SC 125 4T 06-07, RUNNER VXR RACE 200 125 4T 06-06, RUNNER VXR 4T ST EU3 200 4T 08-11, RUNNER VXR EU3 200 4T 07-07, OREGON 250 4T 06-10</p>	<p>PIAGGIO BEVERLY EU3 125 4T 07-08, BEVERLY EURO 3 MIC 125 4T 07-07, BEVERLY EURO 3 SPORT 125 4T 07-08, BEVERLY RST 125 4T 05-07, BEVERLY TOURER EU3 125 4T 07-10, CARNABY 125 4T 07-10, MP3 125 4T 06-08, VESPA GRANTURISMO 125 4T 06-07, VESPA GRANTURISMO EU3 125 4T 06-07, VESPA GTS EU3 125 4T 07-12, VESPA GTV 125 4T 06-08, VESPA GTV 4T NAVY EU3 125 4T 08-08, X-EVO 125 4T 07-16, X7 EU3 125 4T 08-08, X8 125 4T 05-06, X8 PREMIUM EU2 125 4T 06-06, X8 PREMIUM EU3 125 4T 06-07, X9 EVOLUTION 125 4T 05-06, X9 EVOLUTION EU3 125 4T 07-07, CARNABY 200 4T 07-08, VESPA GRANTURISMO 200 4T 03-07, X8 200 4T 05-07, BEVERLY 250 4T 05-07, X9 EVOLUTION 250 4T 04-04, X9 EVOLUTION 250 4T 06-06</p>
--	--



cod. MC12107

Membrana carburatore adattabile scooter Piaggio Vespa Lx 125 cc

RIFERIMENTO ORIGINALE

Aprilia	AP8540170	Piaggio	CM140302
---------	-----------	---------	----------

APPLICABILITÀ

<p>APRILIA MOJITO 125 4T 03-08, SPORT CITY ONE 4T EU3 125 4T 08-11, SR MOTARD 125 4T-2V 12-14</p> <p>DERBI BOULEVARD 4T EU3 125 4T 08-12, BOULEVARD EU2 125 4T 04-07, SONAR 4T 125 4T 09-11, VARIANT SPORT 4T EU3 125 4T 12-12, BOULEVARD 4T E3 150 4T 10-10, SONAR 4T 150 4T 09-09, BOULEVARD EU2 200 4T 05-06</p>	<p>PIAGGIO FLY 125 4T 05-07, FLY EU3 125 4T 07-11, LIBERTY 4T 125 4T 06-07, LIBERTY 4T 2V EURO3 125 4T 09-12, LIBERTY 4T EU3 125 4T 06-08, LIBERTY 4T EU3 DELIVERY - SINGLE 125 4T 07-15, LIBERTY 4T EU3 DELIVERY - TNT 125 4T 08-15, LIBERTY 4T SPORT EU3 125 4T 06-08, LIBERTY RST PTT 125 4T 05-11, LIBERTY SPORT 125 4T 06-06, VESPA GRANTURISMO 125 4T 03-05, VESPA LX 125 4T 05-06, VESPA LX 4T FL 125 4T 09-09, VESPA LX EU3 125 4T 06-08, VESPA LXV 4T EU3 125 4T 06-09, VESPA LXV NAVY EU3 125 4T 07-08, VESPA S 4T EU3 125 4T 07-08, X8 STREET EU2 125 4T 06-07, FLY 150 4T 05-07, FLY EU3 150 4T 08-11, LIBERTY 4T EU3 150 4T 08-08, LIBERTY 4T SPORT EU3 150 4T 08-08, LIBERTY MOC 4T 150 4T 09-13, VESPA LX 150 4T 05-06, VESPA LX 4T FL 150 4T 09-09, VESPA LX EU3 150 4T 06-08, VESPA S 4T 150 4T 08-09, X8 STREET EU2 150 4T 06-08, LIBERTY 200 4T 06-06, LIBERTY 4T EU3 200 4T 06-08, LIBERTY 4T SPORT EU3 200 4T 06-07, LIBERTY SPORT 200 4T 06-06</p>
---	---



cod. MC12108

Membrana carburatore adattabile a scooter PIAGGIO ZIP 50 cc 4T

RIFERIMENTO ORIGINALE

Piaggio	CM146601
---------	----------

APPLICABILITÀ

<p>PIAGGIO FLY 4T 50 4T 05-07, FLY 4T & 25-30 KM/H 50 4T 08-11, FLY 4T 2V 50 4T 13-15, FLY 4T 2V 25-30KM/H 50 4T 12-17, FLY 4T MOTORE CHN 50 4T 06-07, LIBERTY 4T 50 4T 00-02, LIBERTY 4T 50 4T 05-08, LIBERTY 4T DELIVERY - SINGLE 50 4T 10-14, LIBERTY 4T DELIVERY TNT 50 4T 09-09, LIBERTY 4T PTT (DEU) 50 4T 07-12, LIBERTY 4T PTT - DOUBLE - NEXIVE 50 4T 09-17, LIBERTY 4T RST 50 4T 04-04, LIBERTY 4T SPORT 50 4T 06-08, LIBERTY MOC 4T & ELLE 50 4T 09-16, VESPA ET4 50 4T 00-05, VESPA LX 4T 50 4T 05-09, ZIP 4T 50 4T 00-13, ZIP 4T 25KM/H 50 4T 06-16</p>



◀ cod. **9980200**

Molla a gas per sella T-Max 500/530/560 cc '08-'20

RIFERIMENTO ORIGINALE

YAMAHA	4B52478G0200
--------	--------------

YAMAHA	4B52478G0400
--------	--------------

APPLICABILITÀ

Yamaha T-MAX 4B5 500 4T 09-11, T-MAX 4B5 ABS 500 4T 08-11, T-MAX 5VU 500 4T 08-08, T-MAX 5VU BLACK MAX 500 4T 06-06, T-MAX SV 500 4T 11-11, T-MAX SV ABS 500 4T 10-11, T-MAX WHITE MAX 500 4T 10-10, T-MAX 59C 530 4T 12-16, T-MAX 59C ABS 530 4T 12-16, T-MAX 59C SP 530 4T 15-15, T-MAX 59C SP ABS 530 4T 15-16, XP530-A T-MAX SX 530 4T 17-19, XP530D-A T-MAX DX 530 4T 17-19, XP530E-A T-MAX 530 4T 17-18



◀ cod. **9980210**

Molla a gas per sella Yamaha Majesty 400 cc

APPLICABILITÀ

YAMAHA MAJESTY 400 4T 04-11, MAJESTY ABS 400 4T 07-11

RIFERIMENTO ORIGINALE

YAMAHA	34B2478G0000
--------	--------------

YAMAHA	5RU2478G0000
--------	--------------



◀ cod. **9980220**

Molla a gas per sella Honda Silverwing 400/600 cc

APPLICABILITÀ

HONDA SILVER WING [FJS] 400 4T 06-08, SW-T [FJS] 400 4T 09-13, SILVER WING [FJS] 600 4T 01-10, SW-T [FJS] 600 4T 11-13

RIFERIMENTO ORIGINALE

Honda	83590-MCT-003
-------	---------------

Honda	83590-MCT-D61
-------	---------------



◀ cod. **9980230**

Molla a gas per sella Kymco DOWNTOWN 125/350 cc

APPLICABILITÀ

KYMCO DOWNTOWN E4 125 4T 16-16, DOWNTOWN I 125 4T 09-16, DOWNTOWN I 200 4T 10-10, DOWNTOWN ABS 300 4T 10-10, DOWNTOWN I 300 4T 09-09, DOWNTOWN I 300 4T 11-11, DOWNTOWN I ABS 300 4T 11-16, DOWNTOWN ABS E4 350 4T 16-16, DOWNTOWN I ABS 350 4T 15-15, DOWNTOWN I TCS EURO4 350 4T 19-19

RIFERIMENTO ORIGINALE

Kymco	00177103
-------	----------

Kymco	77500-LEA7-E00
-------	----------------

NOVITÀ



◀ cod. **9980250**

Molla a gas per sella Yamaha X-Max 125/250/400 cc dal 2013

RIFERIMENTO ORIGINALE

YAMAHA	15DF478G0000
--------	--------------

APPLICABILITÀ

YAMAHA X-MAX R 125 4T-4V 14-16, X-MAX RA ABS 125 4T-4V 14-16, X-MAX 250 4T 14-16, X-MAX ABS 250 4T 14-15, X-MAX 400 4T-4V 13-16, X-MAX ABS 400 4T-4V 14-17, X-MAX IRONMAX ABS 400 4T-4V 16-16, X-MAX MOMODESIGN 400 4T-4V 14-14, X-MAX MOMODESIGN ABS 400 4T-4V 14-14



◀ cod. **9980260**

Molla a gas per sella Suzuki Burgman 400 cc K7-L6

RIFERIMENTO ORIGINALE

SUZUKI	45270-05H01-000
--------	-----------------

APPLICABILITÀ

SUZUKI AN BURGMAN K7/L0 400 4T 07-10, AN BURGMAN L1 400 4T 11-11, AN BURGMAN L2 400 4T 12-12, AN BURGMAN L3 400 4T 13-13, AN BURGMAN L4 400 4T 14-14, AN BURGMAN L5 400 4T 15-15, AN BURGMAN L6 400 4T 16-16



◀ cod. **9980270**

Molla a gas per sella Honda Integra 700/750cc

RIFERIMENTO ORIGINALE

Honda	83010-MGS-305
-------	---------------

Honda	83590-MGS-D71
-------	---------------

APPLICABILITÀ

HONDA INTEGRA 700 12-13, INTEGRA 750 03-21

NOVITÀ

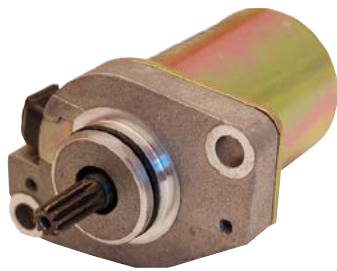

◀ **cod. MA0001**
Motorino avviamento Minarelli

RIFERIMENTO ORIGINALE

Aprilia	AP8224103
Benelli	R19240011A0
Malaguti	2404400
Yamana	45BH18001000

Yamana	4CUH18001000
MBK	45BH18001000
MBK	4CUH18001000

APPLICABILITÀ

APRILIA AMICO 50 2T 94-94, AMICO 50 2T 96-98, AMICO GL/GLE 50 2T 93-95, AMICO LX/SPORT/CAT 50 2T 92-93, AREA 51 50 2T 98-00, GULLIVER 50 2T 95-98, GULLIVER LC 50 2T 96-98, RALLY 50 2T 95-03, RALLY LIQUID COOLED 50 2T 96-99, SCARABEO 50 2T 93-05, SONIC 50 2T 98-07, SONIC GP 50 2T 98-08, SR (ORIZZONTALE) 50 2T 94-96, SR (VERTICALE) 50 2T 93-93, SR LIQUID COOLED 50 2T 94-96, SR RACING 50 2T 97-99, SR STEALTH 50 2T 97-00, SR WWW 50 2T 97-01

ATALA CAROSELLO 50 2T 99-01

BENELLI 491 GT 50 2T 98-99, 491 NAKED 50 2T 02-02, 491 RACING 50 2T 98-99, 491 RR 50 2T 99-01, 491 SP 50 2T 99-99, 491 SPORT 50 2T 98-99, 491 ST 50 2T 99-01, K2 50 2T 98-01, K2 LIQUID COOLED 50 2T 98-01, PEPE 50 2T 99-01, PEPE LX 50 2T 03-04

BETA ARK 50 2T 96-08, ARK LC 50 2T 96-08, CHRONO 50 2T 95-96, EIKON 50 2T 99-03, QUADRA 50 2T 95-95, QUADRA 50 2T 99-01, TEMPO 50 2T 93-02, TEMPO 50 2T 95-95

ITALJET DRAGSTER 50 2T 98-02

KTM K50 50 2T 96-01

MACAL STING 50 2T 95-96, THUNDER 50 2T 95-96

MALAGUTI CENTRO SL 50 2T 94-98, CIAK 50 2T 99-01, CIAK EURO 2 2,3 50 2T 03-03, CIAK EURO2 50 2T 01-03, CIAK MASTER EURO 2 50 2T 06-06, F10 50 2T 92-00, F10 EURO 2 50 2T 02-06, F10 EURO 2,3 50 2T 03-04, F10 RESTYLING EURO 2 50 2T 06-06, F12 PHANTOM 50 2T 94-98, F12 PHANTOM EURO 2 50 2T 02-02, F12 PHANTOM EURO 2,3 50 2T 03-04, F12 PHANTOM LC 50 2T 94-98, F12 PHANTOM LC EURO 2,3 50 2T 03-04, F12 R PHANTOM LC 50 2T 07-10, F12 RESTYLING EURO 1 50 2T 99-02, F12 RESTYLING EURO 2 50 2T 06-06, F12 RESTYLING LC EURO 2 50 2T 06-06, F15 FIRE FOX 50 2T 96-98, F15 FIRE FOX AIR COOLED 50 2T 05-06, F15 FIRE FOX EURO 2 50 2T 02-06, F15 FIRE FOX EURO 2,3 50 2T 03-04, YESTERDAY 50 2T 97-00

MBK BOOSTER 50 2T 90-04, BOOSTER 50 2T 90-94, BOOSTER EURO 2 50 2T 04-04, BOOSTER NG 50 2T 95-03, BOOSTER ROCKET 50 2T 97-98, BOOSTER SPIRIT 50 2T 96-00, BOOSTER SPIRIT 50 2T 03-03, BOOSTER SPIRIT EURO2 50 2T 03-03, BOOSTER TRACK 50 2T 96-98, EVOLIS 50 2T 92-95, FIZZ 50 2T 94-95, FLIPPER 50 2T 98-04, FLIPPER EURO 2 50 2T 03-03, FORTE 50 2T 94-96, MACH G 50 2T 02-04, MACH G LC 50 2T 02-04, NITRO 50 2T 97-04, NITRO EURO 2 50 2T 03-03, OVETTO 50 2T 97-04, OVETTO EURO 2 50 2T 02-02, STUNT 50 2T 00-02

MOTRON STING 50 2T 95-96, SYNCRO 50 2T 98-00, THUNDER 50 2T 95-98

RIEJU FIRST 50 2T 95-98, WINDY 50 2T 95-98

YAMAHA AEROX 50 2T 97-02, AEROX 50 2T 04-16, AEROX EURO 2 50 2T 03-03, AEROX NAKED 50 2T 13-16, AEROX R 50 2T 99-00, AXIS 50 2T 95-96, BREEZE 50 2T 94-95, BW'S 50 2T 97-16, BW'S BUMP 50 2T 97-98, BW'S EASY 50 2T 13-13, BW'S NAKED 50 2T 03-04, BW'S NAKED 50 2T 09-16, BW'S NEXT GENERATION 50 2T 97-06, BW'S ORIGINAL 50 2T 99-01, BW'S ORIGINAL EURO 2 50 2T 03-03, JOG R 50 2T 02-02, JOG R EURO2 50 2T 02-02, JOG R EURO2 50 2T 06-15, JOG R LC 50 2T 02-15, NEO'S 50 2T 97-02, NEO'S 50 2T 04-16, NEO'S EASY 50 2T 13-13, NEO'S EURO 2 50 2T 02-02, RS SPY 50 2T 95-98, SLIDER 50 2T 00-02, WHY 50 2T 98-05, WHY EURO 2 50 2T 03-05, ZEST 50 2T 95-92, ZUMA 50 2T 97-01

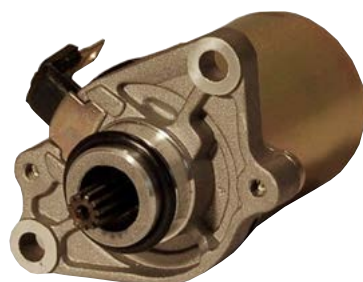

◀ **cod. MA0002**
Motorino avviamento Piaggio

RIFERIMENTO ORIGINALE

Piaggio	82530R
---------	--------

APPLICABILITÀ

APRILIA MOJITO CUSTOM 2T MOTORE PIAGGIO 50 2T 04-10, SCARABEO 2T EU2 MOTORE PIAGGIO 50 2T 10-12, SCARABEO 2T NET 50 2T 09-10, SCARABEO STREET 50 2T 05-06, SCARABEO STREET 2T RESTYLING 50 2T 06-09, SPORT CITY ONE 2T 50 2T 08-11, SR MOTARD 50 2T 12-14, SR R FACTORY CARBURATORE 50 2T 10-14, SR STREET CARBURATORE 50 2T 03-12

DERBI ATLANTIS 2T 50 2T 10-10, ATLANTIS 2T EU2 50 2T 07-09, ATLANTIS O2 50 2T 02-02, ATLANTIS O2 BULLET 50 2T 03-05, ATLANTIS O2 CITY 50 2T 04-06, ATLANTIS O2 RED BULLET 50 2T 03-03, ATLANTIS O2 TWO CHIC 50 2T 05-05, BOULEVARD 2T 50 2T 09-14, GP1 50 2T 01-03, GP1 EU 2 50 2T 05-05, GP1 OPEN EU2 50 2T 06-09, GP1 RACE EU2 50 2T 05-07, SONAR 2T 50 2T 09-09

GILERA DNA 50 2T 00-02, DNA 50 2T 05-07, DNA GP EXPERIENCE 50 2T 03-04, EASY MOVING 50 2T 95-96, ICE 50 2T 01-05, RUNNER 50 2T 97-00, RUNNER POGGIALI 50 2T 02-02, RUNNER SP 50 2T 02-07, RUNNER SP 50 2T 10-12, RUNNER SP SPECIAL EDITION 50 2T 07-07, RUNNER SP ST & SIMONCELLI 50 2T 08-09, STALKER 50 2T 97-11, STALKER NAKED 50 2T 08-08, STALKER SPECIAL EDITION 50 2T 07-08, STORM 50 2T 94-95, STORM EURO 2 50 2T 07-07, TYPHOON 50 2T 94-97, TYPHOON X 50 2T 98-99, TYPHOON XR 50 2T 00-00

PIAGGIO DIESIS 50 2T 01-01, FLY 2T 50 2T 05-07, FLY 2T 50 2T 10-11, FREE 50 2T 92-94, FREE DELIVERY 50 2T 00-01, FREE FL 50 2T 95-02, LIBERTY 50 2T 97-05, LIBERTY 2T 50 2T 06-08, LIBERTY 2T PTT EU2 50 2T 04-05, LIBERTY 2T RST 50 2T 04-04, LIBERTY 2T SPORT 50 2T 06-08, NRG 50 2T 94-96, NRG EXTREME LC 50 2T 99-00, NRG MC3 50 2T 01-04, NRG POWER DD 50 2T 05-17, NRG POWER DD SERIE SPECIALE 50 2T 07-12, NRG POWER DT 50 2T 06-15, NRG POWER DT SERIE SPECIALE 50 2T 07-08, NRG RST MC2 50 2T 96-98, NIT 50 2T 95-96, QUARTZ 50 2T 92-96, SFERA 50 2T 91-93, SFERA MAQUILLAGE 2 50 2T 94-94, SFERA RST 50 2T 95-97, TYPHOON 50 2T 01-11, TYPHOON 2T E2 50 2T 10-12, TYPHOON 2T E3 CH 50 2T 11-11, VESPA ET2 50 2T 97-05, VESPA ET2 INIEZIONE 50 2T 97-00, VESPA LX 2T 50 2T 05-08, VESPA LX 2T TOURING & 30KM 50 2T 10-13, VESPA LXV 2T 50 2T 06-09, VESPA LXV 2T NAVY 50 2T 08-08, VESPA S 2T & COLLEGE 50 2T 07-12, ZIP 50 2T 92-93, ZIP 50 2T 95-96, ZIP 2T 50 2T 08-13, ZIP BIMODALE 50 2T 94-97, ZIP FAST RIDER 50 2T 93-94, ZIP FAST RIDER RST 50 2T 96-97, ZIP LC 50 2T 00-04, ZIP SP 50 2T 96-04, ZIP SP EURO 2 50 2T 06-13



◀ cod. **MA00004**
Motorino avviamento Peugeot/Sym 125cc 12v 9 denti Ø 11,4 rotazione dx

RIFERIMENTO ORIGINALE

Sym	31200H9A000	Peugeot	801068
-----	-------------	---------	--------

APPLICABILITÀ

SYM GTS JOYMAX 125 4T 06-07, HD EU3 125 4T-4V 07-08, HD EVO 125 4T-4V 05-06, HD EVO EU3 125 4T-4V 07-08, HD EVO EU3 125 4T-4V 10-11, HD EVO TAMBURO EU3 125 4T-4V 08-09, HD2 125 4T-4V 11-11, JOYRIDE 125 4T-4V 01-02, JOYRIDE EU2 125 4T-4V 05-06, JOYRIDE EU3 125 4T-4V 07-07, JOYRIDE EVO 125 4T-4V 09-10, JOYRIDE 150 4T-4V 01-02



◀ cod. **MA00006**
Motorino avv. Honda Mitsuba sm14 12v/0,45kw 9 denti Ø 11,7 rotazione dx

RIFERIMENTO ORIGINALE

Honda	31200-KGF-901
-------	---------------

APPLICABILITÀ

HONDA @ [NES] 125 4T 00-06, DYLAN [SES] 125 4T 02-04, PANTHEON IE [FES] 125 4T-2V 03-05, PS I [PES] 125 4T 06-10, SH 125 4T-2V 01-04, SH IE SCOOPY 125 4T-2V 05-12, SILVER WING [FES] 125 4T-2V 07-12, @ [NES] 150 4T 00-06, DYLAN [SES] 150 4T 02-04, PANTHEON IE [FES] 150 4T-2V 03-05, PS I [PES] 150 4T 06-10, SH 150 4T-2V 01-04, SH IE SCOOPY 150 4T 05-12, SILVER WING [FES] 150 4T-2V 07-12

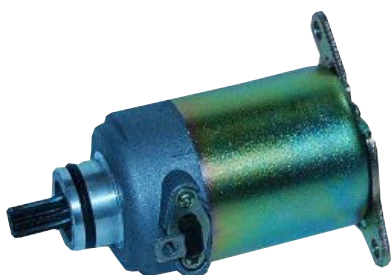

◀ cod. **MA00007**
Motorino avviamento Sym 125 cc 12v rotazione dx

RIFERIMENTO ORIGINALE

Kymco	00126011	Sym	31200M92100
Kymco	00128741	Sym	31200ARA000
Malaguti	54800100		

APPLICABILITÀ

KYMCO AGILITY 125 4T 06-06, AGILITY EU3 125 4T 06-08, AGILITY R16 125 4T 08-09, AGILITY RS 125 4T 09-09, B&W 125 4T 00-00, B&W EU2 125 4T 03-04, DINK 125 4T 97-98, DINK CLASSIC 125 4T 02-02, DINK CLASSIC EU2 125 4T 03-03, DINK LX 125 4T 98-00, HEROISM 125 4T 95-97, LIKE 125 4T 09-09, MOVIE 125 4T 99-00, MOVIE EU3 125 4T 06-07, MOVIE XL EU2 125 4T 03-04, PEOPLE 125 4T 99-00, PEOPLE EU2 125 4T 03-03, PEOPLE EU3 125 4T 07-08, PEOPLE EU3 125 4T 11-11, PEOPLE S 125 4T 05-05, PEOPLE S DD EU3 125 4T 07-08, SUPER 8 125 4T 08-09, VIVIO 125 4T 00-00, AGILITY 150 4T 06-08, AGILITY R16 150 4T 08-09, B&W 150 4T 00-00, B&W EU2 150 4T 03-04, DINK 150 4T 97-98, DINK CLASSIC 150 4T 02-02, DINK CLASSIC EU2 150 4T 03-03, DINK LX 150 4T 98-00, HEROISM 150 4T 95-97, MOVIE EU3 150 4T 06-07, MOVIE XL EU2 150 4T 03-04, PEOPLE 150 4T 99-00, PEOPLE EU2 150 4T 03-03, VIVIO 150 4T 00-00, AGILITY R16 200 4T 12-12, AGILITY R16 200 4T 10-10, DINK CLASSIC 200 4T 04-04, LIKE IE 200 4T 09-09, LIKE LX 200 4T 12-12, PEOPLE S 200 4T 05-05, PEOPLE S 1200 4T 07-07

MALAGUTI CIAK 125 4T 00-01, CIAK MASTER 125 4T 04-04, CIAK MASTER EU3 125 4T 06-06, CIAK RESTYKING EU2 125 4T 03-03, F18 WARRIOR 125 4T 00-02, CIAK 150 4T 00-02, CIAK MASTER 150 4T 04-04, CIAK RESTYKING EU2 150 4T 03-03, F18 WARRIOR 150 4T 00-02, CIAK MASTER EURO 2 200 4T 06-06

SYM FIDDLE II 125 4T 08-09, SUPER DUKE 125 4T 99-02, SYMPLY 125 4T 07-08, SUPER DUKE 150 4T 99-02



◀ cod. **MA00010**
Motorino avviamento Yamaha 250 cc 12v 9 denti Ø 11,7 rotazione dx

RIFERIMENTO ORIGINALE

Aprilia	AP8122628	Malaguti	74800500
Benelli	R19040191A0	Yamaha	4HC818900000
Malaguti	94800100	Yamaha	1COH18000000

APPLICABILITÀ

APRILIA LEONARDO 250 4T 99-04, LEONARDO ST 250 4T 01-01, LEONARDO 300 4T 02-04

BENELLI VELVET 250 4T 99-03

ITALJET JUPITER 250 4T 00-02

MALAGUTI MADISON S 250 4T 99-01, PASSWORD 250 4T 05-06, PASSWORD EU3 250 4T 07-08

MBK SKYLINER 250 4T 00-03, SKYLINER ABS 250 4T 03-03, KILIBRE 300 4T 03-06

YAMAHA MAJESTY 250 4T 96-03, MAJESTY ABS 250 4T 03-03, MAJESTY DX 250 4T 98-99, X-CITY 250 4T 07-15, X-MAX 250 4T 05-16, X-MAX ABS 250 4T 14-15, VERSITY 300 4T 03-06, MAJESTY 400 4T 04-11, MAJESTY ABS 400 4T 07-11, X-MAX 400 4T-4V 13-16, X-MAX ABS 400 4T-4V 14-17, X-MAX IRONMAX ABS 400 4T-4V 16-16, X-MAX MOMODESIGN 400 4T-4V 14-14, X-MAX MOMODESIGN ABS 400 4T-4V 14-14, X-MAX RA 400 4T-4V 18-18



◀ cod. MA00012

Motorino avviamento Piaggio 50 cc 12v/0,45kw rotazione sx 4 spazzole

RIFERIMENTO ORIGINALE

Piaggio	82611R
---------	--------

APPLICABILITÀ

APRILIA ATLANTIC 125 4T 03-05, ATLANTIC EU3 125 4T 06-08, ATLANTIC EU3 125 4T 10-12, MOJITO 125 4T 03-08, SCARABEO 125 4T 03-06, SCARABEO EU3 125 4T 06-07, SPORT CITY 125 4T 04-06, SPORT CITY CUBE 125 4T 08-10, SPORT CITY EU3 125 4T 06-08, SPORT CITY ONE 4T EU3 125 4T 08-11, SPORT CITY STREET 125 4T 12-12, SR MOTARD 125 4T-2V 12-14

DERBI BOULEVARD 125 4T 02-04, BOULEVARD 4T EU3 125 4T 08-12, BOULEVARD EU2 125 4T 04-07, GP1 EU 2 125 4T 06-06, GP1 LOW SEAT EU3 125 4T 07-08, RAMBLA 125 4T 08-09, RAMBLA EU3 2VER 125 4T 08-08, SONAR 4T 125 4T 09-11, VARIANT SPORT 4T EU3 125 4T 12-12, BOULEVARD 150 4T 02-04, BOULEVARD 4T E3 150 4T 10-10, BOULEVARD EU3 150 4T 04-07, SONAR 4T 150 4T 09-09, BOULEVARD EU2 200 4T 05-06

GILERA DNA 125 4T 01-01, NEXUS EU3 125 4T 07-08, RUNNER 4T ST EU3 125 4T 08-16, RUNNER VX 125 4T 00-06, RUNNER VX 4T EU3 125 4T 06-07, RUNNER VX RACE 125 4T 06-06, RUNNER VX SC 125 4T 06-07, RUNNER VXR RACE 200 125 4T 06-06, DNA 180 4T 01-01, RUNNER VXR 180 4T 00-01, RUNNER VXR 200 4T 02-06, RUNNER VXR 4T ST EU3 200 4T 08-11, RUNNER VXR EU3 200 4T 07-07

PIAGGIO BEVERLY 125 4T 01-03, BEVERLY EU3 125 4T 07-08, BEVERLY EURO 3 MIC 125 4T 07-07, BEVERLY EURO 3 SPORT 125 4T 07-08, BEVERLY RST 125 4T 04-07, BEVERLY TOURER EU3 125 4T 07-10, CARNABY 125 4T 07-10, FLY 125 4T 05-07, FLY EU3 125 4T 07-11, HEXAGON GTX 125 4T 00-00, LIBERTY 125 4T 01-02, LIBERTY 4T 125 4T 06-07, LIBERTY 4T 2V EURO3 125 4T 09-12, LIBERTY 4T EU3 125 4T 06-08, LIBERTY 4T EU3 DELIVERY - TNT 125 4T 08-15, LIBERTY 4T SPORT EU3 125 4T 06-08, LIBERTY RST 125 4T 04-05, LIBERTY SPORT 125 4T 06-06, MP3 125 4T 06-08, SKYPPER 4T 125 4T 00-02, SUPER HEXAGON GTX 12 125 4T 01-02, TYPHOON 4T 2V E3 125 4T 10-11, VESPA ET4 125 4T 99-02, VESPA GRANTURISMO 125 4T 03-07, VESPA GRANTURISMO EU3 125 4T 06-07, VESPA GTS EU3 125 4T 07-12, VESPA GTV 125 4T 06-08, VESPA GTV 4T NAVY EU3 125 4T 08-08, VESPA LX 125 4T 05-06, VESPA LX 4T EU3 TOURING 125 4T 10-11, VESPA LX 4T FL 125 4T 09-09, VESPA LX EU3 125 4T 06-08, VESPA LX EU3 IE 125 4T 09-11, VESPA LXV 4T EU3 125 4T 06-09, VESPA LXV IE 4T 125 4T 10-13, VESPA LXV NAVY EU3 125 4T 07-08, VESPA S 4T EU3 125 4T 07-08, VESPA S 4T IE & COLLEGE 125 4T 09-11, X-EVO 125 4T 07-16, X7 EU3 125 4T 08-08, X8 125 4T 04-06, X8 PREMIUM EU2 125 4T 06-06, X8 PREMIUM EU3 125 4T 06-07, X8 STREET EU2 125 4T 06-07, X9 125 4T 01-02, X9 EVOLUTION 125 4T 03-03, X9 EVOLUTION 125 4T 05-06, X9 EVOLUTION EU3 125 4T 07-07, ZIP 125 4T 00-02, FLY 150 4T 05-07, FLY EU3 150 4T 08-11, LIBERTY 4T EU3 150 4T 08-08, LIBERTY 4T SPORT EU3 150 4T 08-08, LIBERTY MOC 4T 150 4T 09-13, SKYPPER 4T 150 4T 00-02, VESPA ET4 150 4T 99-02, VESPA LX 150 4T 05-06, VESPA LX 4T FL 150 4T 09-09, VESPA LX EU3 150 4T 06-08, VESPA LX EU3 IE 150 4T 09-11, VESPA LXTOURING 150 4T 10-12, VESPA S 4T 150 4T 08-09, VESPA S 4T IE & COLLEGE 150 4T 09-12, X8 STREET EU2 150 4T 06-08, HEXAGON GTX 180 4T 00-00, SUPER HEXAGON GTX 12 180 4T 01-02, X9 AMALFI 180 4T 00-03, CARNABY 200 4T 07-08, LIBERTY 200 4T 06-06, LIBERTY 4T EU3 200 4T 06-08, LIBERTY 4T SPORT EU3 200 4T 06-07, LIBERTY RST 200 4T 04-04, LIBERTY SPORT 200 4T 06-06, VESPA GRANTURISMO 200 4T 03-07, X8 200 4T 05-07, X9 200 4T 02-03, X9 EVOLUTION 200 4T 03-03



◀ cod. MA00014

Motorino avviamento Kymco 50 cc 12v/0,20kw rotazione sx

RIFERIMENTO ORIGINALE

Kymco	00104202
-------	----------

Sym	31200GAK900
-----	-------------

APPLICABILITÀ

KYMCO B&W 50 2T 02-02, B&W EU2 50 2T 03-03, DINK LC 50 2T 98-02, DINK CLASSIC EU2 50 2T 03-03, HEROISM 50 2T 95-97, KXR 50 2T 04-04, MAXXR 50 2T 05-05, MXER 50 2T 02-03, MXER EU2 50 2T 04-04, MXU 50 2T 06-07, MXU SR 50 2T 06-06, PEOPLE 50 2T 99-04, PEOPLE EURO 2 50 2T 03-03, PEOPLE EURO 2 50 2T 08-08, PEOPLE EURO 2 50 2T 11-11, PEOPLE S 50 2T 05-08, SNIPER 50 2T 93-93, SNIPER DD 50 2T 94-96, SUPER 9 50 2T 00-00, SUPER 9 EU2 50 2T 03-04, TOP BOY 50 2T 97-00, VITALITY 2T 50 2T 04-04, YUP 50 2T 02-02, YUP EU2 50 2T 03-03

SYM JET 50 2T 99-01, JUNGLE 50 2T 99-00, MASK 50 2T 00-01, MASK EU2 50 2T 03-04, RED DEVIL 50 2T 99-99, SUPER FANCY 50 2T 98-00



◀ cod. MA00015

Motorino avviamento Piaggio 50 cc 12v/0,25kw 10 denti rotazione sx

RIFERIMENTO ORIGINALE

Piaggio	96921R
---------	--------

Malaguti	44800500
----------	----------

APPLICABILITÀ

APRILIA RS 50 2T 06-10, RS4 50 2T 11-13, SCARABEO 4T 50 4T 02-06, SCARABEO 4T 4V 50 4T-4V 10-12, SCARABEO 4T 4V NET 50 4T-4V 09-10, SCARABEO 4T RESTYLING EU3 50 4T 06-09, SCARABEO QUATTRO 50 4T-4V 09-09, SPORT CITY ONE 4T 50 4T 08-10, SR R 50 2T 04-09, SR R FACTORY IE 50 2T 10-14

DERBI ATLANTIS 4T 50 4T 04-06, ATLANTIS 4T EU2 50 4T 07-07, BOULEVARD 4T EU2 25KM/H 50 4T 09-09, GPR R EU2 - GPR REPLICA EU2 50 2T 08-08, GPR RACING EU2 50 2T 06-06, GPR REPLICA & GPR R EU2 50 2T 06-06, GPR REPLICA PESEK EU2 50 2T 07-07, SENDA R DRD PRO EU2 50 2T 05-11, SENDA SM DRD PRO EU2 50 2T 05-11

GILERA RUNNER PURE JET 50 2T-IE 02-07, RUNNER PURE JET 50 2T-IE 10-11, RUNNER PURE JET ST 50 2T-IE 08-08

MALAGUTI CENTRO EURO 2 50 4T 08-08, CENTRO SL 4T 50 4T 10-10, CIAK MASTER 4T 50 4T 05-06

PIAGGIO FLY 4T 50 4T 05-07, FLY 4T & 25-30 KM/H 50 4T 08-11, FLY 4T MOTORE CHN 50 4T 06-07, LIBERTY 4T 50 4T 00-02, LIBERTY 4T 50 4T 05-08, LIBERTY 4T DELIVERY - SINGLE 50 4T 10-14, LIBERTY 4T DELIVERY TNT 50 4T 09-09, LIBERTY 4T PTT - DOUBLE - NEXIVE 50 4T 09-17, LIBERTY 4T RST 50 4T 04-04, LIBERTY 4T SPORT 50 4T 06-08, LIBERTY MOC 2T & ELLE 50 2T 09-13, NRG POWER PUREJET 50 2T-IE 04-11, NRG PUREJET 50 2T-IE 02-04, NRG PUREJET 50 2T-IE 10-10, VESPA ET4 50 4T 00-05, VESPA LX 4T 50 4T 05-09, VESPA LX 4T 4V 50 4T-4V 09-13, VESPA LX 4T 4V TOURING 50 4T-4V 10-13, VESPA S 4T 4V & COLLEGE 50 4T-4V 08-12, ZIP 4T 50 4T 00-13, ZIP RST 50 2T 96-99, DIESEL 100 2T 01-01



cod. MA00016

Motorino avviamento Piaggio 125/250/300 cc 12v/0,45kw 9 denti Ø 11,7 rotazione dx

RIFERIMENTO ORIGINALE

Piaggio	58142R
---------	--------

APPLICABILITÀ

APRILIA SR MAX 125 4T 11-14, ATLANTIC 250 4T 03-05, ATLANTIC EU3 250 4T 06-08, SCARABEO 250 4T 04-06, SCARABEO LIGHT 250 4T 06-08, SPORT CITY CUBE 250 4T 08-12, SPORT CITY EU3 250 4T 06-08, ATLANTIC 300 4T 10-11, SCARABEO LIGHT 300 4T 09-10, SPORT CITY STREET 300 4T-4V 12-12, SR MAX 300 4T 11-14

DERBI GP1 250 4T 06-07, GP1 LOW SEAT EU3 250 4T 07-08, RAMBLA 250 4T 08-09, RAMBLA EU3 2VER 250 4T 08-08, RAMBLA 300 4T 10-11

GILERA NEXUS IE EU3 125 4T 08-10, NEXUS EU3 250 4T 06-07, NEXUS SP EU3 250 4T 06-07, OREGON 250 4T 06-10, NEXUS EU3 300 4T 08-11

PIAGGIO VESPA GTS 4T IE SUPER 125 4T 09-16, X7 EVO IE EU3 125 4T 09-10, BEVERLY 250 4T 05-07, BEVERLY CRUISER 250 4T 07-09, BEVERLY IE EU3 250 4T 06-08, BEVERLY RST 250 4T 04-05, BEVERLY TOURER EU3 250 4T 07-09, CARNABY 250 4T 08-09, MP3 250 4T 06-08, MP3 LT 250 4T 08-09, MP3 MIC 250 4T 08-09, VESPA GT 60 EU3 250 4T 06-07, VESPA GTS 250 4T 05-16, VESPA GTS ABS 250 4T 05-12, VESPA GTV 250 4T 06-09, VESPA GTV 4T NAVY EU3 250 4T 07-07, X-EVO 250 4T 07-16, X7 EU3 250 4T 08-08, X8 EU3 250 4T 05-08, X9 EVOLUTION 250 4T 04-04, X9 EVOLUTION 250 4T 06-06, BEVERLY RST 4V IE EU3 300 4T 10-16, BEVERLY TOURER EU3 300 4T 09-10, CARNABY CRUISER 300 4T 09-12, VESPA GTS IE TOURING 300 4T 11-12, VESPA GTS SUPER 300 4T 08-16, VESPA GTS SUPER SPORT 300 4T 10-13, VESPA GTV 4T 4V IE 300 4T 10-13, VESPA GTV VIA MONTENAPOLEONE 300 4T 10-10, X7 EVO IE EU3 300 4T 09-10

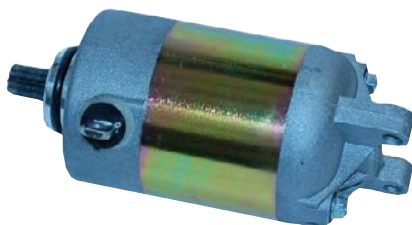

cod. MA00017

Motorino avviamento Minarelli 125/150/180 cc 12v 9 denti Ø 11,5 rotazione sx

RIFERIMENTO ORIGINALE

Benelli	R19010111A0
Malaguti	74800400
Yamaha	4CWH18000000
Yamaha	5MLH18000000

Yamaha	5DSH18000000
Yamaha	5DS818000000
Yamaha	5XLH18000000

APPLICABILITÀ

BENELLI VELVET 125 4T 99-01, VELVET TOURING 125 4T 02-03, VELVET 150 4T 99-01, VELVET TOURING 150 4T 02-03

ITALJET JUPITER 125 4T 01-02, MILLENNIUM 125 4T 00-02, JUPITER 150 4T 01-02, MILLENNIUM 150 4T 00-02

MALAGUTI MADISON 125 4T 99-01, MADISON R RESTYLING 125 4T 02-02, MADISON R RESTYLING EU2 125 4T 03-04, PHANTOM MAX 125 4T 03-03, MADISON T 150 4T 99-01

MBK DOODO 125 4T 00-00, SKYLINER 125 4T 98-02, SKYLINER E 125 4T 03-03, THUNDER 125 4T 01-02, DOODO 150 4T 01-02, SKYLINER 150 4T 00-02, THUNDER 150 4T 01-02, SKYLINER E 180 4T 03-03

YAMAHA CYGNUS R (XC K) 125 4T 97-98, CYGNUS R (XC) 125 4T 99-99, CYGNUS X (NXC) 125 4T 04-06, CYGNUS125 (XC T) 125 4T 95-98, MAJESTY 125 4T 98-00, MAJESTY (SNR1) 125 4T 01-01, MAJESTY (SNR8) 125 4T 02-02, MAJESTY E 125 4T 03-09, MAXSTER 125 4T 01-02, TEO'S 125 4T 00-00, MAJESTY 150 4T 00-00, MAJESTY (SN51) 150 4T 01-01, MAJESTY (SN56) 150 4T 02-02, MAXSTER 150 4T 01-02, TEO'S 150 4T 01-02, MAJESTY E 180 4T 03-06



cod. MA00018

Motorino avviamento Minarelli AM 345/6

RIFERIMENTO ORIGINALE

Aprilia	AP8212367
Piaggio	4800180

Piaggio	2402700
Yamaha	4YVH18002000

APPLICABILITÀ

APRILIA CLASSIC 50 2T 92-99, EUROPA 50 2T 91-92, PEGASO 50 2T 92-94, RS 50 2T 91-05, TUONO 50 2T 03-04

HM BAJA, DERAPAGE BASIC 50 2T 10-11, CRE BAJA RR, DERAPAGE RR 50 2T 07-11, CRE BAJA, DERAPAGE 50 2T 07-11, CRE SIX, BAIA, DERAPAGE 50 2T 95-00, CRE SIX, BAIA, DERAPAGE 50 2T 03-06, DERAPAGE COMPETITION 50 2T 10-11

MALAGUTI FIFTY EVOLUTION 50 2T 90-93

MINARELLI MOTORE AM 6° SERIE 50 2T 96-11, MOTORE AM 6° SERIE 50 2T 12-18

VENT BAJA 50 2T 18-20, BAJA RR 50 2T 18-20, DERAPAGE 50 2T 18-20, DERAPAGE RR 50 2T 18-20

YAMAHA TZR 50 2T 03-08, TZR 50 2T 10-11, TZR RR 50 2T 05-05



cod. MA00019

Motorino avviamento Peugeot 50 cc 12v/0,15kw 11 denti rotazione sx con cavi

RIFERIMENTO ORIGINALE

Peugeot	744049
---------	--------

APPLICABILITÀ

PEUGEOT BUXY 50 2T 90-02, ELYSEO 50 2T 90-02, KISBEE 50 2T 00-00, LOOXOR 50 2T 90-02, LUDIX 50 2T 90-02, METAL X 50 2T 90-02, SPEEDAKE 50 2T 90-02, SPEEDFIGHT 50 2T 97-04, SPEEDFIGHT 3 50 2T 09-14, SPEEDFIGHT LC 50 2T 97-04, SQUAB 50 2T 90-02, TREKKER 50 2T 90-02, VIVACITY 50 2T 90-02, X-FIGHT 50 2T 00-02, X-FIGHT LC 50 2T 00-02, ZENITH 50 2T 90-02



◀ cod. **MA00021**
Motorino avviamento Suzuki 125/150/250/400 cc

RIFERIMENTO ORIGINALE

Suzuki	31100-14F01-000
--------	-----------------

APPLICABILITÀ

SUZUKI EPICURO 125 4T 99-01, UH BURGMAN K2/K6 125 4T 02-06, EPICURO 150 4T 99-01, UH BURGMAN K2/K6 150 4T 02-06, AN BURGMAN K1/K2 250 4T 01-02, AN BURGMAN K3/K6 250 4T 03-06, AN BURGMAN W/X/Y 250 4T 98-00, AN BURGMAN K3/K6 400 4T 03-06, AN BURGMAN X/K2 400 4T 99-02



◀ cod. **MA00022**
Motorino avviamento Aprilia Leonardo/Scarabeo 125 cc (Rotax)

RIFERIMENTO ORIGINALE

Aprilia	AP0296390	Malaguti	65030700
---------	-----------	----------	----------

APPLICABILITÀ

APRILIA LEONARDO 125 4T 96-02, LEONARDO ST 125 4T 03-04, SCARABEO 125 4T 99-03, LEONARDO 150 4T 96-02, SCARABEO 150 4T 99-03, SCARABEO 200 4T 01-03
MALAGUTI BLOG 125 4T 11-11, BLOG IE 125 4T 09-10, CENTRO IE EU3 125 4T 08-09, CENTRO SL 125 4T 11-11, CENTRO SL IE EU3 125 4T 09-10, BLOG 160 4T 11-11, BLOG IE 160 4T 09-10, CENTRO IE EU3 160 4T 08-09, CENTRO SL 160 4T 11-11, CENTRO SL IE EU3 160 4T 09-10



◀ cod. **MA00023**
Motorino avviamento Piaggio Vespa/Ape 50 cc

RIFERIMENTO ORIGINALE

Piaggio	179116
---------	--------

APPLICABILITÀ

PIAGGIO APE 50 2T 09-17, APE EU4 50 2T 18-18, APE FL - FL2 50 2T 89-95, APE FL3 EUROPA 50 2T 96-99, APE MIX 2T 50 2T 98-08, APE RST MIX 50 2T 99-03, APE TM P 50 2T 85-89, VESPA FL 50 2T 90-90, VESPA FL2 AUTOMATICA 50 2T 90-91, VESPA FL2 HP 50 2T 91-97, VESPA N 50 2T 89-90, VESPA PK 50 2T 82-84, VESPA PK AUTOMATICA 50 2T 84-89, VESPA PK XL 50 2T 85-88, VESPA PK XL PLURIMATIC 50 2T 85-90, VESPA PK XL RUSH 50 2T 88-89, VESPA FL 125 2T 89-90



◀ cod. **MA00024**
Motorino Avviamento Peugeot Sym 50 cc 4T

RIFERIMENTO ORIGINALE

SYM	31200A1A000	SYM	31200AWA000
-----	-------------	-----	-------------

APPLICABILITÀ

SYM MIO 50 4T 06-09, SYMPHONY EURO 2 50 4T 09-09, SYMPHONY S 50 4T 10-10, SYMPHONY SR 50 4T 10-10



◀ cod. **MA00025**
Motorino Avviamento Kymco Agility/ People 50 cc 4T

RIFERIMENTO ORIGINALE

Kymco	107242
-------	--------

APPLICABILITÀ

KYMCO AGILITY 4T CARRY 50 4T 11-11, AGILITY 4T R10 50 4T 06-08, AGILITY 4T R12 50 4T 07-08, AGILITY PLUS 4T 50 4T 14-14, AGILITY R12 50 4T 05-05, AGILITY R12 ECS 50 4T 16-16, AGILITY R16 50 4T 08-09, AGILITY R16 50 4T 12-12, AGILITY RS 50 4T 09-09, DINK 50 4T 50 4T 07-07, FILLY 50 4T 98-00, FILLY LX 50 4T 01-02, LIKE 50 4T 09-09, PEOPLE S 4T 50 4T 06-08, SENTO 50 4T 08-08, SUPER 8 4T 50 4T 07-07, SUPER 8 4T 50 4T 09-09



◀ cod. **MA00026**
Motorino Avviamento Sym Symphony 125/150 cc

RIFERIMENTO ORIGINALE

Sym	31200-ARA-000	Sym	31200-M92-100
-----	---------------	-----	---------------

APPLICABILITÀ

SYM EURO MX 125 4T 02-02, EURO MX EU2 125 4T 03-04, SHARK 125 4T 99-02, SYMPHONY 125 4T 09-09, SYMPHONY S 125 4T 09-10, SYMPHONY SR 125 4T 10-10, EURO MX 150 4T 02-02, EURO MX EU2 150 4T 03-04, SHARK 150 4T 00-01, SYMPHONY 150 4T 09-09, SYMPHONY S 150 4T 10-10, SYMPHONY SR 150 4T 10-10



◀ cod. **MA00027**
Motorino Avviamento Kymco Dink 125/200 cc EU3

RIFERIMENTO ORIGINALE

Kymco	128751
-------	--------

APPLICABILITÀ

KYMCO DINK EU3 125 4T 06-07, G-DINK 125 4T 12-12, GRAND DINK 125 4T 01-02, GRAND DINK EU2 125 4T 03-04, GRAND DINK 150 4T 01-02, GRAND DINK EU2 150 4T 03-04



◀ cod. **MA00028**
Motorino Avviamento Yamaha X-MAX 125 cc

RIFERIMENTO ORIGINALE

Yamaha	1B9H18000100
--------	--------------

APPLICABILITÀ

MBK CITYLINER EU3 125 4T-4V 08-10, SKYCRUISER 125 4T-4V 07-07
YAMAHA X-CITY EU3 125 4T-4V 08-11, X-MAX R 125 4T-4V 06-16, X-MAX R ABS 125 4T-4V 11-11, X-MAX RA ABS 125 4T-4V 13-16



◀ cod. **MA00029**
Motorino Avviamento Piaggio Vespa PX 125 cc

RIFERIMENTO ORIGINALE

Piaggio	249235
---------	--------

APPLICABILITÀ

PIAGGIO VESPA PX 125 2T 98-01, VESPA PX 125 2T 11-16, VESPA PX 30 ANNI 125 2T 07-08, VESPA PX E ARCOBALENO 125 2T 81-97, VESPA PX EU2 125 2T 01-07, COSA CL, CLX 150 2T 88-91, VESPA PX 150 2T 98-01, VESPA PX 150 2T 11-16, VESPA PX E ARCOBALENO 150 2T 81-97, VESPA PX E ARCOBALENO 200 2T 81-97



◀ **cod. MA00030**
Motorino avviamento Piaggio 400/500 cc

RIFERIMENTO ORIGINALE

PIAGGIO	82699R
---------	--------

APPLICABILITÀ

APRILIA ATLANTIC SPRINT 400 4T 05-08, SCARABEO LIGHT 400 4T 06-08, ATLANTIC 500 4T 01-04, ATLANTIC SPRINT 500 4T 05-08, SCARABEO 500 4T 03-06, SCARABEO LIGHT 500 4T 06-08

GILERA FUOCO 4T-4V IE E3 LT 500 4T 13-14, FUOCO IE EU3 500 4T 07-13, NEXUS 500 4T 03-05, NEXUS EU3 500 4T 06-11, NEXUS SP EU3 500 4T 06-07

PIAGGIO BEVERLY EU3 400 4T 06-07, BEVERLY TOURER EU3 400 4T 08-10, MP3 400 4T 07-08, MP3 IE LT TOURING 400 4T 11-11, MP3 IE LT/SPORT 400 4T 08-10, MP3 MIC 400 4T 08-10, MP3 RL TOURING 400 4T 11-11, X-EVO 400 4T 07-11, X8 EU3 400 4T 06-08, BEVERLY 500 4T 02-06, BEVERLY CRUISER 500 4T 07-12, BEVERLY IE EU3 500 4T 06-08, MP3 LT BUSINESS ABS 500 4T 14-16, MP3 LT E4 SPORT/BUSINESS 500 4T 16-17, MP3 LT SPORT/BUSINESS 500 4T 11-13, MP3 RL SPORT-BUSINESS 500 4T 11-12, MP3 SPORT ABS 500 4T 14-16, X10 4T-4V IE EU3 500 4T 12-14, X9 500 4T 01-02, X9 EVOLUTION 500 4T 03-07, X9 EVOLUTION ABS 500 4T 06-07



◀ **cod. MA00031**
Motorino avviamento Kymco Xciting 300 cc / Sym Joymax 250 cc

RIFERIMENTO ORIGINALE

Kymco	00128750
Kymco	31210KHE790A

Sym	31200HMA000
-----	-------------

APPLICABILITÀ

KYMCO B&W 250 4T 00-00, B&W EU2 250 4T 03-03, GRAND DINK 250 4T 01-02, GRAND DINK EU2 250 4T 03-04, PEOPLE LC 250 4T 03-04, PEOPLE S 250 4T 06-06, PEOPLE S I 250 4T 07-07, X CITING 250 4T 05-05, X CITING I 250 4T 06-07, YUP 250 4T 03-03, G-DINK 300 4T-2V 12-12, PEOPLE S I 300 4T 08-08, X CITING I 300 4T 08-08, X CITING I R 300 4T 08-09

SYM GTS 250 4T-4V 07-08, JOYMAX 250 4T-4V 05-07, JOYMAX EU3 I 250 4T-4V 07-08, CITYCOM 300 4T-4V 08-09, CITYCOM EFI 300 4T-4V 10-11, CITYCOM I CBS 300 4T-4V 12-12, CITYCOM I S EURO4 300 4T-4V 17-17, CITYCOM S I CBS 300 4T-4V 15-15, JOYMAX EVO 300 4T-4V 09-09, JOYMAX EVO I 300 4T-4V 10-10, JOYMAX I 300 4T-4V 12-12, JOYMAX I 300 4T-4V 14-14, JOYMAX I ABS 300 4T-4V 13-14



◀ **cod. MA00032**
Motorino avviamento Honda SH 300 cc

RIFERIMENTO ORIGINALE

Honda	31200-KTW-901
-------	---------------

APPLICABILITÀ

HONDA SH IE SCOOPY 300 4T-4V 07-19



◀ **cod. MA00033**
Motorino avviamento Yamaha T-Max 500/530 cc

RIFERIMENTO ORIGINALE

Yamaha	4B5818900000
--------	--------------

Yamaha	BC3818900000
--------	--------------

APPLICABILITÀ

YAMAHA T-MAX 4B5 500 4T 09-11, T-MAX 4B5 ABS 500 4T 08-11, T-MAX 5VU 500 4T 08-08, T-MAX 5VU BLACK MAX 500 4T 06-06, T-MAX SV 500 4T 11-11, T-MAX SV ABS 500 4T 10-11, T-MAX WHITE MAX 500 4T 10-10, T-MAX 59C 530 4T 12-16, T-MAX 59C ABS 530 4T 12-16, T-MAX 59C SP 530 4T 15-15, T-MAX 59C SP ABS 530 4T 15-16, XP530-A-T-MAX SX 530 4T 17-19, XP530D-A T-MAX DX 530 4T 17-19, XP530E-A-T-MAX 530 4T 17-18



◀ **cod. 5780BN**

Prestolite

DD 12 Volt, CCW, 10-Tooth Pinion

MAKE / MODEL	YEAR
Harley Davidson FL	1941-1964
Harley Davidson FL Series (Pre 1977)	1965-1976
Harley Davidson FLF	1954-1964
Harley Davidson FLFB	1965-1969
Harley Davidson FLH Electra Glide	1955-1983
Harley Davidson FLHB	1965-1969
Harley Davidson FLHC Electra Glide Classic	1979-1981
Harley Davidson FLHF	1955-1972
Harley Davidson FLHFB	1965-1969
Harley Davidson FLHS Electra Glide Sport	1980-1981
Harley Davidson FLT Tour Glide	1980-1983
Harley Davidson FLTC Tour Glide Classic	1981
Harley Davidson FLTC/I Tour Glide Classic	1981
Harley Davidson FXR Super Glide II	1982-1983
Harley Davidson FXRS Low Glide	1982-1983
Harley Davidson XLC	1958
Harley Davidson XLCH	1958-1979
Harley Davidson XLCH Sportster	1975-1978
Harley Davidson XLCR Cafe Racer	1977-1978
Harley Davidson XLH Sportster	1975-1985
Harley Davidson XLH Sportster Anniv.	1978
Harley Davidson XLH Touring	1977
Harley Davidson XLH1000	1972-1980
Harley Davidson XLH900	1958-1971
Harley Davidson XLHA Sportster Annv.	1982
Harley Davidson XLR	1959-1960
Harley Davidson XLRTT	1958-1964
Harley Davidson XLS Roadster	1978-1985
Harley Davidson XLSA Roadster Anniv.	1982
Harley Davidson XLT	1977-1978
Harley Davidson XLX-61	1983-1985
Harley Davidson XR	1969-1975
Harley Davidson XR1000	1983-1985



◀ **cod. 5780CN**

Prestolite

DD 12 Volt, CCW, 10-Tooth Pinion

MAKE / MODEL	YEAR
Harley Davidson FL	1941-1964
Harley Davidson FL Series (Pre 1977)	1965-1976
Harley Davidson FLF	1953-1964
Harley Davidson FLFB	1965-1969
Harley Davidson FLH Electra Glide	1955-1983
Harley Davidson FLHB	1965-1969
Harley Davidson FLHC Electra Glide Classic	1979-1981
Harley Davidson FLHF	1955-1972
Harley Davidson FLHFB	1965-1969
Harley Davidson FLHS Electra Glide Sport	1980-1981
Harley Davidson FLT Tour Glide	1980-1983

◀ **cod. 5780CN** - continued

MAKE / MODEL	YEAR
Harley Davidson FLTC Tour Glide Classic	1981
Harley Davidson FLTC/I Tour Glide Classic	1981
Harley Davidson FXR Super Glide II	1982-1983
Harley Davidson FXRS Low Glide	1982-1983
Harley Davidson XLC	1958
Harley Davidson XLCH	1958-1979
Harley Davidson XLCH Sportster	1975-1978
Harley Davidson XLCR Cafe Racer	1977-1978
Harley Davidson XLH Sportster	1975-1985
Harley Davidson XLH Sportster Anniv.	1978
Harley Davidson XLH Touring	1977
Harley Davidson XLH1000	1972-1980
Harley Davidson XLH900	1958-1971
Harley Davidson XLHA Sportster Anniv.	1982
Harley Davidson XLR	1959-1960
Harley Davidson XLRTT	1958-1964
Harley Davidson XLS Roadster	1978-1985
Harley Davidson XLSA Roadster Anniv.	1982
Harley Davidson XLT	1977-1978
Harley Davidson XLX-61	1983-1985
Harley Davidson XR	1969-1975
Harley Davidson XR1000	1983-1985



◀ **cod. 11834N**

KTM PMDD
12 Volt, CW, 9-Tooth Pinion

MAKE / MODEL	YEAR
KTM 250 SX-F	2012-2014
KTM 350 EXC-F	2012-2014
KTM 350 Freeride	2012
KTM 350 SX-F	2011-2014
KTM 350 XC-F	2012-2014
KTM 350 XCF-W	2012-2014
KTM 450 SX-F	2014



◀ **cod. 11835N**

KTM PMDD
0.5kW/12 Volt, CCW, 9-Tooth Pinion

MAKE / MODEL	YEAR
KTM 450 SX-F	2013
KTM 450 SX-F Factory Edition	2013
KTM 450 XC-F	2011-2013
KTM 450 XC-W	2012-2014
KTM 500 EXC	2012-2014
KTM 500 EXC Six Days	2012
KTM 500 XC-W	2012-2014



◀ **cod. 15410BN**

Prestolite
10 Amp/12 Volt, CCW



MAKE / MODEL	YEAR
Harley Davidson FL Series (Pre 1977)	1965-1969
Harley Davidson FLFB	1965-1969
Harley Davidson FLHB	1965-1969
Harley Davidson XLC	1958
Harley Davidson XLCH	1958-1979
Harley Davidson XLCR Cafe Racer	1977-1978
Harley Davidson XLH Sportster	1979-1984
Harley Davidson XLH1000	1972-1981
Harley Davidson XLHA Sportster Annv.	1982
Harley Davidson XLS Roadster	1979-1984
Harley Davidson XLSA Roadster Anniv.	1982
Harley Davidson XLX-61	1983-1984
Harley Davidson XR1000	1983-1985



◀ **cod. 16071N**

Mitsuba PMDD
12 Volt



MAKE / MODEL	YEAR
Honda CBR250R	2011-2013
Honda CBR300R	2015-2016



◀ **cod. 16072N**

Mitsuba PMDD
12 Volt, 9-Tooth Pinion



MAKE / MODEL	YEAR
Honda SH300	2007-2013



◀ **cod. 16073N**

Mitsuba PMDD
12 Volt, CW



MAKE / MODEL	YEAR
Aprilia Atlantic 400 Sprint	2005-2008
Aprilia Atlantic 500	2001-2005
Aprilia Atlantic 500 Sprint	2005-2008
Aprilia Scarabeo 500	2003-2006
Aprilia Scarabeo 500 Light	2006-2013
Aprilia Scarabeo 500 Sprint	2006



◀ **cod. 16075N**
Mitsuba PMDD
12 Volt, CW, 9-Tooth Pinion

MAKE / MODEL	YEAR
Yamaha WR450F	2007-2015



◀ **cod. 16079N**
Mitsuba PMDD
12 Volt, CCW, 9-Tooth Pinion

MAKE / MODEL	YEAR
Yamaha TTR125E	2003-2007
Yamaha TTR125LE	2003-2007



◀ **cod. 16087N**
Mitsuba PMDD
12 Volt, CCW, 9-Tooth Pinion

MAKE / MODEL	YEAR
Suzuki GSF1250S Bandit	2007-2009
Suzuki GSF1250SA Bandit ABS	2007-2009
Suzuki GSX1250FA	2011

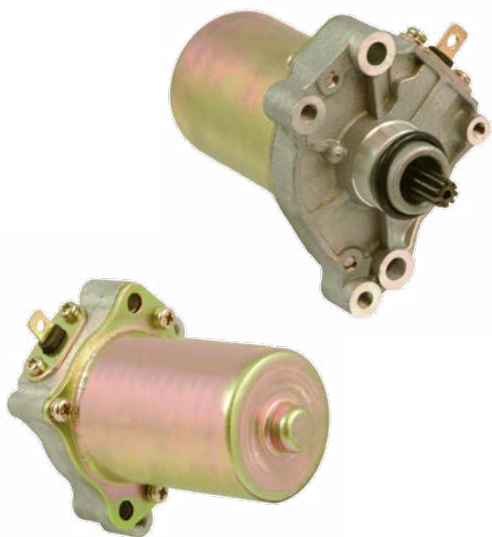

◀ **cod. 16088N**
Mitsuba PMDD
12 Volt, CCW, 12-Tooth Pinion

MAKE / MODEL	YEAR
Aprilia Scarabeo 100	2002-2008
Aprilia Scarabeo 100 4T	2006-2010
Aprilia SR 125	1999-2001
Aprilia SR 150	1999-2001
Piaggio Fly 100	All
Piaggio Free 100	All
Piaggio Hexagon 125	All
Piaggio Hexagon 150	All
Piaggio Hexagon 180	All
Piaggio Skipper 125	All
Piaggio Skipper 150	All
Piaggio Zip 100	All



◀ **cod. 16090N**
Mitsuba PMDD
12 Volt, CCW, 9-Tooth Pinion

MAKE / MODEL	YEAR
Yamaha YW125 Zuma 125	2009-2015

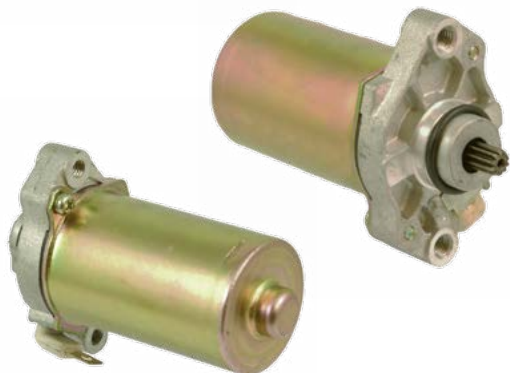

◀ **cod. 16091N**
Mitsuba PMDD
12 Volt, CCW, 10-Tooth Pinion

MAKE / MODEL	YEAR
Peugeot - Europe Elystar 50	All
Peugeot - Europe Jet Force 50	All
Peugeot - Europe Looxor 50 TDSI	All



◀ **cod. 17629BN**
Denso OSGR
1.4kW/12 Volt, CW, 18 Tooth Spline

MAKE / MODEL	YEAR
Harley Davidson FLHS Electra Glide Sport	1989-1993
Harley Davidson FLHTC Electra Glide Classic	1989-1993
Harley Davidson FLHTCI Electra Glide Classic	1989-1993
Harley Davidson FLHTCU Electra Glide Ultra Classic	1989-1993
Harley Davidson FLHTCUI Electra Glide Ultra Classic	1989-1993
Harley Davidson FLHTP Police	1989
Harley Davidson FLSTC Heritage Softail Classic	1989-1993
Harley Davidson FLSTCI Heritage Softail Classic	1988-1993
Harley Davidson FLSTF Fat Boy	1990-1993
Harley Davidson FLSTFI Fat Boy	1990-1993
Harley Davidson FLSTI Heritage Softail	1989-1990
Harley Davidson FLSTN Heritage Softail Nostalgia	1993
Harley Davidson FLSTNI Softail Deluxe	1993
Harley Davidson FLTC Tour Glide Classic	1989-1991
Harley Davidson FLTC/I Tour Glide Classic	1989-1991
Harley Davidson FLTCU Tour Glide Ultra Classic	1989-1993
Harley Davidson FLTCUI Tour Glide Ultra Classic	1989-1993
Harley Davidson FXDB-D Dyna Glide Daytona	1992
Harley Davidson FXDB-S Dyna Glide Sturgis	1991
Harley Davidson FXDC Super Glide Custom	1992
Harley Davidson FXDL Dyna Low Rider	1993
Harley Davidson FXDLI Dyna Low Rider	1993
Harley Davidson FXDWG Dyna Wide Glide	1993
Harley Davidson FXDWGI Dyna Wide Glide	1993
Harley Davidson FXLR Low Rider Custom	1989-1993
Harley Davidson FXR Super Glide II	1989-1993

◀ **cod. 17629BN** - continued

MAKE / MODEL	YEAR
Harley Davidson FXRP Police	1989
Harley Davidson FXRS Low Glide	1989-1992
Harley Davidson FXRS-Conv Low Rider Sport Convertible	1990-1993
Harley Davidson FXRS-SP Low Rider Sport	1986-1993
Harley Davidson FXRT Sport Glide	1989-1992
Harley Davidson FXST Softail Standard	1989-1990
Harley Davidson FXSTC Softail Custom	1989-1993
Harley Davidson FXSTI Softail Standard	1989-1990
Harley Davidson FXSTS Springer Softail	1989-1993
Harley Davidson FXSTSI Springer Softail	1989-1993



◀ **cod. 17629CN**

Denso OSGR
1.4kW/12 Volt, CW, Chrome

MAKE / MODEL	YEAR
Harley Davidson FLHS Electra Glide Sport	1989-1993
Harley Davidson FLHTC Electra Glide Classic	1989-1993
Harley Davidson FLHTCI Electra Glide Classic	1989-1993
Harley Davidson FLHTCU Electra Glide Ultra Classic	1989-1993
Harley Davidson FLHTCUI Electra Glide Ultra Classic	1989-1993
Harley Davidson FLHTP Police	1989
Harley Davidson FLSTC Heritage Softail Classic	1989-1993
Harley Davidson FLSTCI Heritage Softail Classic	1988-1993
Harley Davidson FLSTF Fat Boy	1990-1993
Harley Davidson FLSTFI Fat Boy	1990-1993
Harley Davidson FLSTI Heritage Softail	1989-1990
Harley Davidson FLSTN Heritage Softail Nostalgia	1993
Harley Davidson FLSTNI Softail Deluxe	1993
Harley Davidson FLTC Tour Glide Classic	1989-1991
Harley Davidson FLTC/I Tour Glide Classic	1989-1991
Harley Davidson FLTCU Tour Glide Ultra Classic	1989-1993
Harley Davidson FLTCUI Tour Glide Ultra Classic	1989-1993
Harley Davidson FXDB-D Dyna Glide Daytona	1992
Harley Davidson FXDB-S Dyna Glide Sturgis	1991
Harley Davidson FXDC Super Glide Custom	1992
Harley Davidson FXDL Dyna Low Rider	1993
Harley Davidson FXDLI Dyna Low Rider	1993
Harley Davidson FXDWG Dyna Wide Glide	1993
Harley Davidson FXDWGI Dyna Wide Glide	1993
Harley Davidson FXLR Low Rider Custom	1989-1993
Harley Davidson FXR Super Glide II	1989-1993
Harley Davidson FXRP Police	1989
Harley Davidson FXRS Low Glide	1989-1992
Harley Davidson FXRS-Conv Low Rider Sport Convertible	1990-1993
Harley Davidson FXRS-SP Low Rider Sport	1986-1993
Harley Davidson FXRT Sport Glide	1989-1992
Harley Davidson FXST Softail Standard	1989-1990
Harley Davidson FXSTC Softail Custom	1989-1993
Harley Davidson FXSTI Softail Standard	1989-1990
Harley Davidson FXSTS Springer Softail	1989-1993
Harley Davidson FXSTSI Springer Softail	1989-1993



◀ **cod. 17629CN-HT**

Denso OSGR
1.8kW/12 Volt, CW, Chrome

MAKE / MODEL	YEAR
Harley Davidson FLHS Electra Glide Sport	1991-1993
Harley Davidson FLHTC Electra Glide Classic	1991-1993
Harley Davidson FLHTCI Electra Glide Classic	1991-1993
Harley Davidson FLHTCU Electra Glide Ultra Classic	1991-1993
Harley Davidson FLHTCUI Electra Glide Ultra Classic	1991-1993
Harley Davidson FLSTC Heritage Softail Classic	1991-1993
Harley Davidson FLSTCI Heritage Softail Classic	1992-1993
Harley Davidson FLSTF Fat Boy	1991-1993
Harley Davidson FLSTFI Fat Boy	1991-1993
Harley Davidson FLSTN Heritage Softail Nostalgia	1993
Harley Davidson FLSTNI Softail Deluxe	1993
Harley Davidson FLTC Tour Glide Classic	1991
Harley Davidson FLTC/I Tour Glide Classic	1991
Harley Davidson FLTCU Tour Glide Ultra Classic	1991-1993
Harley Davidson FLTCUI Tour Glide Ultra Classic	1991-1993
Harley Davidson FXDB-D Dyna Glide Daytona	1992
Harley Davidson FXDB-S Dyna Glide Sturgis	1991
Harley Davidson FXDC Super Glide Custom	1992
Harley Davidson FXDL Dyna Low Rider	1993
Harley Davidson FXDLI Dyna Low Rider	1993
Harley Davidson FXDWG Dyna Wide Glide	1993
Harley Davidson FXDWGI Dyna Wide Glide	1993
Harley Davidson FXLR Low Rider Custom	1991-1993
Harley Davidson FXR Super Glide II	1991-1993
Harley Davidson FXRS Low Glide	1991-1992
Harley Davidson FXRS-Conv Low Rider Sport Convertible	1991-1993
Harley Davidson FXRS-SP Low Rider Sport	1991-1993
Harley Davidson FXRT Sport Glide	1991-1992
Harley Davidson FXSTC Softail Custom	1991-1993
Harley Davidson FXSTS Springer Softail	1991-1993
Harley Davidson FXSTSI Springer Softail	1991-1993



◀ **cod. 17629N**

Denso OSGR
1.4kW/12 Volt, CW

MAKE / MODEL	YEAR
Harley Davidson FLHS Electra Glide Sport	1991-1993
Harley Davidson FLHTC Electra Glide Classic	1991-1993
Harley Davidson FLHTCI Electra Glide Classic	1991-1993
Harley Davidson FLHTCU Electra Glide Ultra Classic	1991-1993
Harley Davidson FLHTCUI Electra Glide Ultra Classic	1991-1993
Harley Davidson FLSTC Heritage Softail Classic	1991-1993
Harley Davidson FLSTCI Heritage Softail Classic	1991-1993
Harley Davidson FLSTF Fat Boy	1991-1993
Harley Davidson FLSTFI Fat Boy	1991-1993
Harley Davidson FLSTN Heritage Softail Nostalgia	1993
Harley Davidson FLSTNI Softail Deluxe	1993
Harley Davidson FLTC Tour Glide Classic	1991

◀ **cod. 17629N** - continued

MAKE / MODEL	YEAR
Harley Davidson FLTC/I Tour Glide Classic	1991
Harley Davidson FLTCU Tour Glide Ultra Classic	1991-1993
Harley Davidson FLTCUI Tour Glide Ultra Classic	1991-1993
Harley Davidson FXDB-D Dyna Glide Daytona	1992
Harley Davidson FXDB-S Dyna Glide Sturgis	1991
Harley Davidson FXDC Super Glide Custom	1992
Harley Davidson FXDL Dyna Low Rider	1993
Harley Davidson FXDLI Dyna Low Rider	1993
Harley Davidson FXDWG Dyna Wide Glide	1993
Harley Davidson FXDWGI Dyna Wide Glide	1993
Harley Davidson FXLR Low Rider Custom	1991-1993
Harley Davidson FXR Super Glide II	1991-1993
Harley Davidson FXRS Low Glide	1991-1992
Harley Davidson FXRS-Conv Low Rider Sport Convertible	1991-1993
Harley Davidson FXRS-SP Low Rider Sport	1991-1993
Harley Davidson FXRT Sport Glide	1991-1992
Harley Davidson FXSTC Softail Custom	1991-1993
Harley Davidson FXSTS Springer Softail	1991-1993
Harley Davidson FXSTSI Springer Softail	1991-1993



◀ **cod. 18199BN**

Denso OSGR

1.4kW/12 Volt, CW, 18-Tooth Spline

MAKE / MODEL	YEAR
Harley Davidson FLHR Road King	1994-2006
Harley Davidson FLHRCI Road King Classic	1998-2006
Harley Davidson FLHRI Road King	1996-2006
Harley Davidson FLHRS Road King Custom	2004-2006
Harley Davidson FLHRSEI Screamin Eagle Road King	2002
Harley Davidson FLHRSI Road King Custom	2004-2006
Harley Davidson FLHT Electra Glide Standard	1995-2006
Harley Davidson FLHTC Electra Glide Classic	1994-2005
Harley Davidson FLHTCI Electra Glide Classic	1994-2006
Harley Davidson FLHTCU Electra Glide Ultra Classic	1994-1997
Harley Davidson FLHTCUI Electra Glide Ultra Classic	1995-2006
Harley Davidson FLHTI Electra Glide Standard	1995-2006
Harley Davidson FLHX Street Glide	2006
Harley Davidson FLHXI Street Glide	2006
Harley Davidson FLST Heritage Softail	2006
Harley Davidson FLSTC Heritage Softail Classic	1994-2006
Harley Davidson FLSTCI Heritage Softail Classic	1994-2006
Harley Davidson FLSTF Fat Boy	1994-2006
Harley Davidson FLSTFI Fat Boy	1994-2006
Harley Davidson FLSTI Heritage Softail	2006
Harley Davidson FLSTN Heritage Softail Special	1994-1996
Harley Davidson FLSTN Softail Deluxe	2005-2006
Harley Davidson FLSTNI Softail Deluxe	1993-2006
Harley Davidson FLSTS Heritage Springer	1997-2003
Harley Davidson FLSTSC Softail Springer Classic	2005-2006
Harley Davidson FLSTSCI Softail Springer Classic	2005-2006

◀ cod. **18199BN** - continued

MAKE / MODEL	YEAR
Harley Davidson FLSTSI Heritage Springer	1997-2003
Harley Davidson FLTCU Tour Glide Ultra Classic	1994-1995
Harley Davidson FLTCUI Tour Glide Ultra Classic	1994-1996
Harley Davidson FLTR Road Glide	1998-2002
Harley Davidson FLTRI Road Glide	1998-2006
Harley Davidson FLTRSEI Screamin Eagle Road Glide	2000
Harley Davidson FLTRSEI2 Screamin Eagle Road Glide 2	2001
Harley Davidson FXD Dyna Super Glide	1995-2005
Harley Davidson FXD35 Super Golden Anniversary	2006
Harley Davidson FXDBI Street Bob	2006
Harley Davidson FXDC Super Glide Custom	2005
Harley Davidson FXDCI Super Glide Custom	2005-2006
Harley Davidson FXDI Dyna Super Glide	1995-2006
Harley Davidson FXDL Dyna Low Rider	1994-2005
Harley Davidson FXDLI Dyna Low Rider	1994-2006
Harley Davidson FXDS-Conv Dyna Convertible	1994-2000
Harley Davidson FXDWG Dyna Wide Glide	1994-2005
Harley Davidson FXDWG2	2001
Harley Davidson FXDWG3	2002
Harley Davidson FXDWGI Dyna Wide Glide	1994-2006
Harley Davidson FXDX Dyna Super Glide Sport	1999-2005
Harley Davidson FXDXI Dyna Super Glide Sport	2004-2005
Harley Davidson FXDXT Dyna Super Glide T-Sport	2001-2003
Harley Davidson FXLR Low Rider Custom	1994
Harley Davidson FXR Super Glide II	1994
Harley Davidson FXR2	1999
Harley Davidson FXR3	1999
Harley Davidson FXR4	2000
Harley Davidson FXST Softail Standard	1999-2006
Harley Davidson FXSTB Night Train	1999-2006
Harley Davidson FXSTBI Night Train	1999-2006
Harley Davidson FXSTC Softail Custom	1994-1999
Harley Davidson FXSTD Softail Deuce	2000-2006
Harley Davidson FXSTDI Softail Deuce	2000-2006
Harley Davidson FXSTDSE Screamin Eagle Softail Deuce	2003
Harley Davidson FXSTDSE2 Screamin Eagle Softail Deuce 2	2004
Harley Davidson FXSTI Softail Standard	1999-2006
Harley Davidson FXSTS Springer Softail	1994-2006
Harley Davidson FXSTSB Bad Boy	1995-1997
Harley Davidson FXSTSI Springer Softail	1994-2006



◀ cod. **18199CN**

Denso OSGR

1.4kW/12 Volt, CW, Chrome, 18-Tooth Spline

MAKE / MODEL	YEAR
Harley Davidson FLHRCI Road King Classic	1998-2006
Harley Davidson FLHRI Road King	1996-2006
Harley Davidson FLHRSEI Screamin Eagle Road King	2002
Harley Davidson FLHRSI Road King Custom	2004-2006
Harley Davidson FLHT Electra Glide Standard	1995-2006

◀ cod. **18199CN** - continued

MAKE / MODEL	YEAR
Harley Davidson FLHTCI Electra Glide Classic	1994-2006
Harley Davidson FLHTCUI Electra Glide Ultra Classic	1995-2006
Harley Davidson FLHTI Electra Glide Standard	1995-2006
Harley Davidson FLHXI Street Glide	2006
Harley Davidson FLST Heritage Softail	2006
Harley Davidson FLSTC Heritage Softail Classic	1994-2006
Harley Davidson FLSTCI Heritage Softail Classic	1994-2006
Harley Davidson FLSTF Fat Boy	1994-2006
Harley Davidson FLSTFI Fat Boy	1994-2006
Harley Davidson FLSTI Heritage Softail	2006
Harley Davidson FLSTN Heritage Softail Special	1994-1996
Harley Davidson FLSTN Softail Deluxe	2005-2006
Harley Davidson FLSTNI Softail Deluxe	1993-2006
Harley Davidson FLSTS Heritage Springer	1997-2003
Harley Davidson FLSTSCI Softail Springer Classic	2005-2006
Harley Davidson FLSTSI Heritage Springer	1997-2003
Harley Davidson FLTCU Tour Glide Ultra Classic	1994-1995
Harley Davidson FLTCUI Tour Glide Ultra Classic	1994-1996
Harley Davidson FLTR Road Glide	1998-2002
Harley Davidson FLTRI Road Glide	1998-2006
Harley Davidson FLTRSEI Screamin Eagle Road Glide	2000
Harley Davidson FLTRSEI2 Screamin Eagle Road Glide 2	2001
Harley Davidson FXD Dyna Super Glide	1995-2005
Harley Davidson FXDBI Street Bob	2006
Harley Davidson FXDC Super Glide Custom	2005
Harley Davidson FXDCI Super Glide Custom	2005-2006
Harley Davidson FXDI Dyna Super Glide	1995-2006
Harley Davidson FXDL Dyna Low Rider	1994-2005
Harley Davidson FXDLI Dyna Low Rider	1994-2006
Harley Davidson FXDS-Conv Dyna Convertible	1994-2000
Harley Davidson FXDWG Dyna Wide Glide	1994-2005
Harley Davidson FXDWG2	2001
Harley Davidson FXDWG3	2002
Harley Davidson FXDWGI Dyna Wide Glide	1994-2003
Harley Davidson FXDX Dyna Super Glide Sport	1999-2005
Harley Davidson FXDXI Dyna Super Glide Sport	2004-2005
Harley Davidson FXDXT Dyna Super Glide T-Sport	2001-2003
Harley Davidson FXLR Low Rider Custom	1994
Harley Davidson FXR Super Glide II	1994
Harley Davidson FXR2	1999
Harley Davidson FXR3	1999
Harley Davidson FXR4	2000
Harley Davidson FXST Softail Standard	1999-2006
Harley Davidson FXSTB Night Train	1999-2006
Harley Davidson FXSTBI Night Train	1999-2006
Harley Davidson FXSTC Softail Custom	1994-1999
Harley Davidson FXSTD Softail Deuce	2000-2006
Harley Davidson FXSTDI Softail Deuce	2000-2006
Harley Davidson FXSTDSE Screamin Eagle Softail Deuce	2003
Harley Davidson FXSTDSE2 Screamin Eagle Softail Deuce 2	2004
Harley Davidson FXSTI Softail Standard	1999-2006
Harley Davidson FXSTS Springer Softail	1994-2006
Harley Davidson FXSTSB Bad Boy	1995-1997
Harley Davidson FXSTSI Springer Softail	1994-2006



◀ cod. **18199N**
Denso OSGR
1.4kW/12 Volt, CW, 18-Tooth Spline

MAKE / MODEL	YEAR
Harley Davidson FLHR Road King	1994-2006
Harley Davidson FLHRCI Road King Classic	1998-2006
Harley Davidson FLHRI Road King	1996-2006
Harley Davidson FLHRS Road King Custom	2004-2006
Harley Davidson FLHRSEI Screamin Eagle Road King	2002
Harley Davidson FLHRSI Road King Custom	2004-2006
Harley Davidson FLHT Electra Glide Standard	1995-2006
Harley Davidson FLHTC Electra Glide Classic	1994-2005
Harley Davidson FLHTCI Electra Glide Classic	1994-2006
Harley Davidson FLHTCU Electra Glide Ultra Classic	1994-1997
Harley Davidson FLHTCUI Electra Glide Ultra Classic	1995-2006
Harley Davidson FLHTI Electra Glide Standard	1995-2006
Harley Davidson FLHX Street Glide	2006
Harley Davidson FLHXI Street Glide	2006
Harley Davidson FLST Heritage Softail	2006
Harley Davidson FLSTC Heritage Softail Classic	1994-2006
Harley Davidson FLSTCI Heritage Softail Classic	1994-2006
Harley Davidson FLSTF Fat Boy	1994-2006
Harley Davidson FLSTFI Fat Boy	1994-2006
Harley Davidson FLSTI Heritage Softail	2006
Harley Davidson FLSTN Heritage Softail Special	1994-1996
Harley Davidson FLSTN Softail Deluxe	2005-2006
Harley Davidson FLSTNI Softail Deluxe	1993-2006
Harley Davidson FLSTS Heritage Springer	1997-2003
Harley Davidson FLSTSC Softail Springer Classic	2005-2006
Harley Davidson FLSTSCI Softail Springer Classic	2005-2006
Harley Davidson FLSTSI Heritage Springer	1997-2003
Harley Davidson FLTCU Tour Glide Ultra Classic	1994-1995
Harley Davidson FLTCUI Tour Glide Ultra Classic	1994-1996
Harley Davidson FLTR Road Glide	1998-2002
Harley Davidson FLTRI Road Glide	1998-2006
Harley Davidson FLTRSEI Screamin Eagle Road Glide	2000
Harley Davidson FLTRSEI2 Screamin Eagle Road Glide 2	2001
Harley Davidson FXD Dyna Super Glide	1995-2005
Harley Davidson FXD35 Super Golden Anniversary	2006
Harley Davidson FXDBI Street Bob	2006
Harley Davidson FXDC Super Glide Custom	2005
Harley Davidson FXDCI Super Glide Custom	2005-2006
Harley Davidson FXDI Dyna Super Glide	1995-2006
Harley Davidson FXDL Dyna Low Rider	1994-2005
Harley Davidson FXDLI Dyna Low Rider	1994-2006
Harley Davidson FXDS-Conv Dyna Convertible	1994-2000
Harley Davidson FXDWG Dyna Wide Glide	1994-2005
Harley Davidson FXDWG2	2001
Harley Davidson FXDWG3	2002
Harley Davidson FXDWGI Dyna Wide Glide	1994-2006
Harley Davidson FXDX Dyna Super Glide Sport	1999-2005
Harley Davidson FXDXI Dyna Super Glide Sport	2004-2005
Harley Davidson FXDXT Dyna Super Glide T-Sport	2001-2003
Harley Davidson FXLR Low Rider Custom	1994
Harley Davidson FXR Super Glide II	1994
Harley Davidson FXR2	1999

◀ **cod. 18199N** - continued

MAKE / MODEL	YEAR
Harley Davidson FXR3	1999
Harley Davidson FXR4	2000
Harley Davidson FXST Softail Standard	1999-2006
Harley Davidson FXSTB Night Train	1999-2006
Harley Davidson FXSTBI Night Train	1999-2006
Harley Davidson FXSTC Softail Custom	1994-1999
Harley Davidson FXSTD Softail Deuce	2000-2006
Harley Davidson FXSTDI Softail Deuce	2000-2006
Harley Davidson FXSTDSE Screamin Eagle Softail Deuce	2003
Harley Davidson FXSTDSE2 Screamin Eagle Softail Deuce 2	2004
Harley Davidson FXSTI Softail Standard	1999-2006
Harley Davidson FXSTS Springer Softail	1994-2006
Harley Davidson FXSTSB Bad Boy	1995-1997
Harley Davidson FXSTSI Springer Softail	1994-2006



◀ **cod. 18300BN**

Hitachi DD
12 Volt, CCW, 10-Tooth Pinion

MAKE / MODEL	YEAR
Harley Davidson FLH Electra Glide	1984-1985
Harley Davidson FLHC Electra Glide Classic	1980
Harley Davidson FLHS Electra Glide Sport	1984-1988
Harley Davidson FLHT Electra Glide Standard	1986-1987
Harley Davidson FLHTC Electra Glide Classic	1983-1988
Harley Davidson FLHTCI Electra Glide Classic	1983-1988
Harley Davidson FLHTI Electra Glide Standard	1986-1987
Harley Davidson FLHTP Police	1985-1988
Harley Davidson FLHX Electra Glide Special	1984-1985
Harley Davidson FLST Heritage Softail	1986-1990
Harley Davidson FLSTC Heritage Softail Classic	1988
Harley Davidson FLSTI Heritage Softail	1986-1988
Harley Davidson FLT Tour Glide	1983
Harley Davidson FLTC Tour Glide Classic	1982-1988
Harley Davidson FLTC/I Tour Glide Classic	1982-1988
Harley Davidson FX Super Glide	1971-1978
Harley Davidson FXB Sturgis	1980-1982
Harley Davidson FXDG Disc Glide	1983
Harley Davidson FXE Super Glide	1974-1984
Harley Davidson FXEF Fat Bob	1979-1985
Harley Davidson FXLR Low Rider Custom	1987-1988
Harley Davidson FXR Super Glide II	1983-1988
Harley Davidson FXRC Low Rider Chrome	1985-1987
Harley Davidson FXRD Sport Glide Grand Touring	1986
Harley Davidson FXRDG Disc Glide	1984
Harley Davidson FXRP Police	1985-1988
Harley Davidson FXRS Low Glide	1984-1988
Harley Davidson FXRS Low Rider Liberty	1986
Harley Davidson FXRT Sport Glide	1983-1988
Harley Davidson FXS Low Rider	1977-1982
Harley Davidson FXSB Low Rider - Belt	1983-1985

◀ cod. **18300BN** - continued

MAKE / MODEL	YEAR
Harley Davidson FXST Softail Standard	1984-1988
Harley Davidson FXSTC Softail Custom	1986-1988
Harley Davidson FXSTI Softail Standard	1984-1988
Harley Davidson FXSTS Springer Softail	1988
Harley Davidson FXSTSI Springer Softail	1988
Harley Davidson FXWG Wide Glide	1980-1986
Harley Davidson XLCH	1974-1976



◀ cod. **18300CN**

Hitachi DD
12 Volt, CCW, 10-Tooth Pinion

MAKE / MODEL	YEAR
Harley Davidson FLH Electra Glide	1984-1985
Harley Davidson FLHC Electra Glide Classic	1980
Harley Davidson FLHS Electra Glide Sport	1984-1988
Harley Davidson FLHT Electra Glide Standard	1986-1987
Harley Davidson FLHTC Electra Glide Classic	1983-1988
Harley Davidson FLHTCI Electra Glide Classic	1983-1988
Harley Davidson FLHTI Electra Glide Standard	1986-1987
Harley Davidson FLHTP Police	1985-1988
Harley Davidson FLHX Electra Glide Special	1984-1985
Harley Davidson FLST Heritage Softail	1986-1990
Harley Davidson FLSTC Heritage Softail Classic	1988
Harley Davidson FLSTI Heritage Softail	1986-1988
Harley Davidson FLT Tour Glide	1983
Harley Davidson FLTC Tour Glide Classic	1982-1988
Harley Davidson FLTC/I Tour Glide Classic	1982-1988
Harley Davidson FX Super Glide	1971-1978
Harley Davidson FXB Sturgis	1980-1982
Harley Davidson FXDG Disc Glide	1983
Harley Davidson FXE Super Glide	1974-1984
Harley Davidson FXEF Fat Bob	1979-1985
Harley Davidson FXLR Low Rider Custom	1987-1988
Harley Davidson FXR Super Glide II	1983-1988
Harley Davidson FXRC Low Rider Chrome	1985-1987
Harley Davidson FXRD Sport Glide Grand Touring	1986
Harley Davidson FXRDG Disc Glide	1984
Harley Davidson FXRP Police	1985-1988
Harley Davidson FXRS Low Glide	1984-1988
Harley Davidson FXRS Low Rider Liberty	1986
Harley Davidson FXRT Sport Glide	1983-1988
Harley Davidson FXS Low Rider	1977-1982
Harley Davidson FXSB Low Rider - Belt	1983-1985
Harley Davidson FXST Softail Standard	1984-1988
Harley Davidson FXSTC Softail Custom	1986-1988
Harley Davidson FXSTI Softail Standard	1984-1988
Harley Davidson FXSTS Springer Softail	1988
Harley Davidson FXSTSI Springer Softail	1988
Harley Davidson FXWG Wide Glide	1980-1986
Harley Davidson XLCH	1974-1976



◀ cod. **18446CN**

Denso OSGR

2.0kW/12 Volt, CW, Chrome, 18-Tooth Spline

MAKE / MODEL	YEAR
Harley Davidson FLHR Road King	1994-2006
Harley Davidson FLHRCI Road King Classic	1998-2006
Harley Davidson FLHRI Road King	1996-2006
Harley Davidson FLHRS Road King Custom	2004-2006
Harley Davidson FLHRSEI Screamin Eagle Road King	2002
Harley Davidson FLHRSI Road King Custom	2004-2006
Harley Davidson FLHT Electra Glide Standard	1995-2006
Harley Davidson FLHTC Electra Glide Classic	1994-2005
Harley Davidson FLHTCI Electra Glide Classic	1994-2006
Harley Davidson FLHTCU Electra Glide Ultra Classic	1994-1997
Harley Davidson FLHTCUI Electra Glide Ultra Classic	1994-2006
Harley Davidson FLHTI Electra Glide Standard	1995-2006
Harley Davidson FLHX Street Glide	2006
Harley Davidson FLSTC Heritage Softail Classic	1994-2006
Harley Davidson FLSTCI Heritage Softail Classic	1994-2006
Harley Davidson FLSTF Fat Boy	1994-2006
Harley Davidson FLSTFI Fat Boy	1994-2006
Harley Davidson FLSTI Heritage Softail	2006
Harley Davidson FLSTN Heritage Softail Special	1994-1996
Harley Davidson FLSTN Softail Deluxe	2005-2006
Harley Davidson FLSTNI Softail Deluxe	1993-2006
Harley Davidson FLSTS Heritage Springer	1997-2003
Harley Davidson FLSTSC Softail Springer Classic	2005-2006
Harley Davidson FLSTSCI Softail Springer Classic	2005-2006
Harley Davidson FLSTSI Heritage Springer	1997-2003
Harley Davidson FLTCU Tour Glide Ultra Classic	1994-1995
Harley Davidson FLTCUI Tour Glide Ultra Classic	1994-1996
Harley Davidson FLTR Road Glide	1998-2002
Harley Davidson FLTRI Road Glide	1998-2006
Harley Davidson FLTRSEI Screamin Eagle Road Glide	2000
Harley Davidson FLTRSEI2 Screamin Eagle Road Glide 2	2001
Harley Davidson FXD Dyna Super Glide	1995-2005
Harley Davidson FXD35 Super Golden Anniversary	2006
Harley Davidson FXDBI Street Bob	2006
Harley Davidson FXDC Super Glide Custom	2005
Harley Davidson FXDCI Super Glide Custom	2005-2006
Harley Davidson FXDI Dyna Super Glide	1995-2006
Harley Davidson FXDL Dyna Low Rider	1994-2005
Harley Davidson FXDLI Dyna Low Rider	1994-2006
Harley Davidson FXDS-Conv Dyna Convertible	1994-2000
Harley Davidson FXDWG Dyna Wide Glide	1994-2005
Harley Davidson FXDWG2	2001
Harley Davidson FXDWG3	2002
Harley Davidson FXDWGI Dyna Wide Glide	1994-2006
Harley Davidson FXDX Dyna Super Glide Sport	1999-2005
Harley Davidson FXDXI Dyna Super Glide Sport	2004-2005
Harley Davidson FXDXT Dyna Super Glide T-Sport	2001-2003
Harley Davidson FXLR Low Rider Custom	1994
Harley Davidson FXR Super Glide II	1994
Harley Davidson FXR2	1999
Harley Davidson FXR3	1999
Harley Davidson FXR4	2000

◀ cod. 18446CN - continued

MAKE / MODEL	YEAR
Harley Davidson FXST Softail Standard	1999-2006
Harley Davidson FXSTB Night Train	1999-2006
Harley Davidson FXSTBI Night Train	1999-2006
Harley Davidson FXSTC Softail Custom	1994-1999
Harley Davidson FXSTD Softail Deuce	2000-2006
Harley Davidson FXSTDI Softail Deuce	2000-2006
Harley Davidson FXSTDSE Screamin Eagle Softail Deuce	2003
Harley Davidson FXSTDSE2 Screamin Eagle Softail Deuce 2	2004
Harley Davidson FXSTI Softail Standard	2000-2006
Harley Davidson FXSTS Springer Softail	1994-2006
Harley Davidson FXSTSB Bad Boy	1995-1997
Harley Davidson FXSTSI Springer Softail	1994-2006



◀ cod. 18446N

Denso OSGR

2.0kW/12 Volt, CW, 18-Tooth Spline

MAKE / MODEL	YEAR
Harley Davidson FLHR Road King	1994-1999
Harley Davidson FLHRCI Road King Classic	1998-2006
Harley Davidson FLHRI Road King	1996-2006
Harley Davidson FLHRS Road King Custom	2004-2006
Harley Davidson FLHRSEI Screamin Eagle Road King	2002
Harley Davidson FLHRSI Road King Custom	2004-2006
Harley Davidson FLHT Electra Glide Standard	1995-2006
Harley Davidson FLHTC Electra Glide Classic	1994-2005
Harley Davidson FLHTCI Electra Glide Classic	1994-2006
Harley Davidson FLHTCU Electra Glide Ultra Classic	1994-1997
Harley Davidson FLHTCUI Electra Glide Ultra Classic	1994-2006
Harley Davidson FLHTI Electra Glide Standard	1995-2006
Harley Davidson FLHX Street Glide	2006
Harley Davidson FLSTC Heritage Softail Classic	1994-2006
Harley Davidson FLSTCI Heritage Softail Classic	1994-2006
Harley Davidson FLSTF Fat Boy	1994-2006
Harley Davidson FLSTFI Fat Boy	1994-2006
Harley Davidson FLSTI Heritage Softail	2006
Harley Davidson FLSTN Heritage Softail Special	1994-1996
Harley Davidson FLSTN Softail Deluxe	2005-2006
Harley Davidson FLSTNI Softail Deluxe	1993-2006
Harley Davidson FLSTS Heritage Springer	1997-2003
Harley Davidson FLSTSC Softail Springer Classic	2005-2006
Harley Davidson FLSTSCI Softail Springer Classic	2005-2006
Harley Davidson FLSTSI Heritage Springer	1997-2003
Harley Davidson FLTCU Tour Glide Ultra Classic	1994-1995
Harley Davidson FLTCUI Tour Glide Ultra Classic	1994-1996
Harley Davidson FLTR Road Glide	1998-2002
Harley Davidson FLTRI Road Glide	1998-2006
Harley Davidson FLTRSEI Screamin Eagle Road Glide	2000
Harley Davidson FLTRSEI2 Screamin Eagle Road Glide 2	2001
Harley Davidson FXD Dyna Super Glide	1995-2005
Harley Davidson FXD35 Super Golden Anniversary	2006
Harley Davidson FXDBI Street Bob	2006
Harley Davidson FXDC Super Glide Custom	2005

◀ **cod. 18446N** - continued

MAKE / MODEL	YEAR
Harley Davidson FXDCI Super Glide Custom	2005-2006
Harley Davidson FXDI Dyna Super Glide	1995-2006
Harley Davidson FXDL Dyna Low Rider	1994-2005
Harley Davidson FXDLI Dyna Low Rider	1994-2006
Harley Davidson FXDS-Conv Dyna Convertible	1994-2000
Harley Davidson FXDWG Dyna Wide Glide	1994-2005
Harley Davidson FXDWG2	2001
Harley Davidson FXDWG3	2002
Harley Davidson FXDWGI Dyna Wide Glide	1994-2006
Harley Davidson FXDX Dyna Super Glide Sport	1999-2005
Harley Davidson FXDXI Dyna Super Glide Sport	2004-2005
Harley Davidson FXDXT Dyna Super Glide T-Sport	2001-2003
Harley Davidson FXLR Low Rider Custom	1994
Harley Davidson FXR Super Glide II	1994
Harley Davidson FXR2	1999
Harley Davidson FXR3	1999
Harley Davidson FXR4	2000
Harley Davidson FXST Softail Standard	1999-2006
Harley Davidson FXSTB Night Train	1999-2006
Harley Davidson FXSTBI Night Train	1999-2006
Harley Davidson FXSTC Softail Custom	1994-1999
Harley Davidson FXSTD Softail Deuce	2000-2006
Harley Davidson FXSTDI Softail Deuce	2000-2006
Harley Davidson FXSTDSE Screamin Eagle Softail Deuce	2003
Harley Davidson FXSTDSE2 Screamin Eagle Softail Deuce 2	2004
Harley Davidson FXSTI Softail Standard	2000-2006
Harley Davidson FXSTS Springer Softail	1994-2006
Harley Davidson FXSTSB Bad Boy	1995-1997
Harley Davidson FXSTSI Springer Softail	1994-2006

◀ **cod. 18477N**

Denso OSGR

1.4kW/12 Volt, CW, 9-Tooth Pinion



MAKE / MODEL	YEAR
Harley Davidson XL1200C Sportster 1200 Custom	1996-2014
Harley Davidson XL1200V Seventy-Two	2012-2014
Harley Davidson XL1200X Forty-Eight	2010-2014
Harley Davidson XL883L SuperLow	2011-2014
Harley Davidson XL883N Iron 883	2009-2014
Harley Davidson XLH Sportster	1981-1990
Harley Davidson XLH Sportster Liberty	1986
Harley Davidson XLH1000	1981-1985
Harley Davidson XLH1100	1986-1987
Harley Davidson XLH1200	1988-1990
Harley Davidson XLH883	1986-1990
Harley Davidson XLH883DLX Sportster 883 Deluxe	1986-1990
Harley Davidson XLH883HUG Sportster 883 Hugger	1987-1990
Harley Davidson XLS Roadster	1981-1985
Harley Davidson XLSA Roadster Anniv.	1982
Harley Davidson XLX 1000	1983-1985
Harley Davidson XLX-61	1983-1985
Harley Davidson XR1000	1983-1985



◀ **cod. 18477NC**
Denso OSGR
1.4kW/12 Volt, CW, 9-Tooth Pinion

MAKE / MODEL	YEAR
Harley Davidson XL Sportster	1993-2003
Harley Davidson XL Sportster Anniv.	1993
Harley Davidson XL Sportster Deluxe	1993-1995
Harley Davidson XL Sportster Hugger	1993-2002
Harley Davidson XL1200C Sportster 1200 Custom	2014
Harley Davidson XL1200L Sportster 1200 Low	2006-2011
Harley Davidson XL1200N Sportster 1200 Nightster	2007-2012
Harley Davidson XL1200R Sportster 1200 Roadster	2004-2008
Harley Davidson XL1200S Sportster 1200 Sport	1996-2003
Harley Davidson XL1200V Seventy-Two	2014
Harley Davidson XL1200X Forty-Eight	2014
Harley Davidson XL50 50th Anniversary Sportster	2007
Harley Davidson XL883 Sportster	2004-2008
Harley Davidson XL883C Sportster 883 Custom	1998-2010
Harley Davidson XL883L Sportster 883 Low	2005-2011
Harley Davidson XL883L SuperLow	2011-2014
Harley Davidson XL883N Iron 883	2014
Harley Davidson XL883R Sportster 883 Roadster	2002-2013
Harley Davidson XLC Sportster Custom	2000-2007
Harley Davidson XLH Sportster	1981-1992
Harley Davidson XLH Sportster Liberty	1986
Harley Davidson XLH1000	1981-1985
Harley Davidson XLH1100	1986-1987
Harley Davidson XLH1200	1988-2003
Harley Davidson XLH883	1986-2003
Harley Davidson XLH883DLX Sportster 883 Deluxe	1986-1995
Harley Davidson XLH883HUG Sportster 883 Hugger	1987-2003
Harley Davidson XLL Sportster Low	2005-2007
Harley Davidson XLN Nightster	2007
Harley Davidson XLR Sportster Roadster	2002-2007
Harley Davidson XLS Roadster	1981-1985
Harley Davidson XLS Sportster Sport	2000-2003
Harley Davidson XLSA Roadster Anniv.	1982
Harley Davidson XLX 1000	1983-1985
Harley Davidson XLX-61	1983-1985
Harley Davidson XR1000	1983-1985
Harley Davidson XR1200	2009-2010
Harley Davidson XR1200X	2010-2013



◀ **cod. 18478N**
Denso PMDD
0.8kW/12 Volt, CCW, 9-Tooth Pinion

MAKE / MODEL	YEAR
Harley Davidson VRSCA V-Rod	2002-2006
Harley Davidson VRSCAW V-Rod	2007-2010
Harley Davidson VRSCB V-Rod	2004-2005
Harley Davidson VRSCD Night Rod	2006-2008
Harley Davidson VRSCDX ANN V-Rod Anniversary Edition	2012
Harley Davidson VRSCDX Night Rod Special	2007-2014

◀ **cod. 18478N** - continued

MAKE / MODEL	YEAR
Harley Davidson VRSCF V-Rod Muscle	2009-2014
Harley Davidson VRSCR Street Rod	2006-2007
Harley Davidson VRSCSE Screamin Eagle V-Rod	2005
Harley Davidson VRSCSE2 Screamin Eagle V-Rod 2	2006
Harley Davidson VRSCX V-Rod	2007
Harley Davidson VRXSE Screamin Eagle Destroyer	2006



◀ **cod. 18478NC**

Denso PMDD
0.8kW/12 Volt, CCW, 9-Tooth Pinion

MAKE / MODEL	YEAR
Harley Davidson VRSCA V-Rod	2002-2006
Harley Davidson VRSCAW V-Rod	2007-2010
Harley Davidson VRSCB V-Rod	2004-2005
Harley Davidson VRSCD Night Rod	2006-2008
Harley Davidson VRSCDX ANN V-Rod Anniversary Edition	2012
Harley Davidson VRSCDX Night Rod Special	2007-2014
Harley Davidson VRSCF V-Rod Muscle	2009-2014
Harley Davidson VRSCR Street Rod	2006-2007
Harley Davidson VRSCSE Screamin Eagle V-Rod	2005
Harley Davidson VRSCSE2 Screamin Eagle V-Rod 2	2006
Harley Davidson VRSCX V-Rod	2007
Harley Davidson VRXSE Screamin Eagle Destroyer	2006



◀ **cod. 18600N**

Mitsuba PMDD
0.6kW/12 Volt, CW, 13-Tooth Pinion

MAKE / MODEL	YEAR
Honda GL1100 Gold Wing	1980-1983
Honda GL1100A Gold Wing Aspencade	1982-1983
Honda GL1100I Gold Wing Interstate	1980-1983

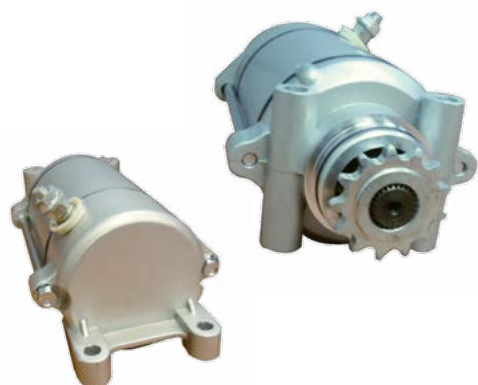

◀ **cod. 18611N**

Mitsuba PMDD
12 Volt, CCW, 13-Tooth Pinion

MAKE / MODEL	YEAR
Honda CB250 Nighthawk	1991-2008
Honda CMX250C Rebel	1996-2015



◀ **cod. 18656N**
Mitsuba PMDD
12 Volt, CW, 10-Spline Shaft

MAKE / MODEL	YEAR
Honda PC800 Pacific Coast	1989-1998
Honda VT1100C Shadow	1995-1996
Honda VT1100C Shadow Spirit	1997-2007
Honda VT1100C2 Shadow Sabre	2004-2007



◀ **cod. 18657N**
Mitsuba PMDD
12 Volt, CCW, 9-Tooth Pinion

MAKE / MODEL	YEAR
Honda ST1100	1991-2003
Honda ST1100 ABS	1992-2003



◀ **cod. 18660N**
Mitsuba PMDD
12 Volt, CCW, 10-Spline Shaft

MAKE / MODEL	YEAR
Honda VF700C Magna	1984-1987
Honda VF700S Sabre	1984-1985
Honda VF750C Magna	1988
Honda VF750C V45 Magna	1982-1983
Honda VF750S V45 Sabre	1982-1983



◀ **cod. 18661N**
Mitsuba PMDD
12 Volt, CW, 10-Tooth Spline

MAKE / MODEL	YEAR
Honda VF700F Interceptor	1984-1985
Honda VF750F V45 Interceptor	1983-1984



◀ **cod. 18671N**
Mitsuba PMDD
12 Volt, CCW, 10-Spline Shaft

MAKE / MODEL	YEAR
Honda NX650	1988-1989
Honda XR650L	1993-2015



◀ **cod. 18690N**
Mitsuba PMDD
12 Volt, CW, 9-Tooth Pinion

MAKE / MODEL	YEAR
Kawasaki KL650B Tengai	1990-1991
Kawasaki KLR650	1987-2015



◀ **cod. 18692N**
Mitsuba PMDD
12 Volt, CCW, 9-Tooth Pinion

MAKE / MODEL	YEAR
Kawasaki VN1500A Vulcan 1500	1996-1999
Kawasaki VN1500A Vulcan 88	1987-1995
Kawasaki VN1500B Vulcan 88 SE	1987-1990
Kawasaki VN1500C Vulcan L	1996-1997
Kawasaki VN1500E Vulcan 1500 Classic	1996-2008
Kawasaki VN1500G Vulcan 1500 Nomad	1999-2001
Kawasaki VN1500J/R Vulcan 1500 Drifter	1999-2005

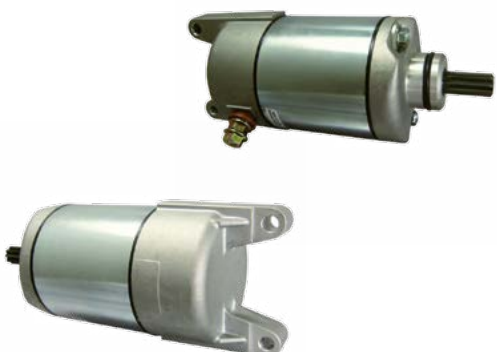

◀ **cod. 18702N**
Mitsuba PMDD
12 Volt, CCW, 9-Tooth Spline

MAKE / MODEL	YEAR
Kawasaki KLF400 Bayou 4x4	1993-1999
Kawasaki KVF400 Prairie 2x4	1998-2002
Kawasaki KVF400 Prairie 4x4	1997-2002



◀ **cod. 18704N**
Mitsuba PMDD
12 Volt, CW, 12-Tooth Pinion

MAKE / MODEL	YEAR
Kawasaki EN450A 454 LTD	1985-1990
Kawasaki EX500	1987-1993
Kawasaki EX500 Ninja 500	1994-1996
Kawasaki EX500 Ninja 500R	1997-2009



◀ **cod. 18715N**
Mitsuba PMDD
12 Volt, 9-Tooth Spline

MAKE / MODEL	YEAR
Kawasaki KL250 Super Sherpa	2000-2010
Kawasaki KLX250S	2006-2007



◀ **cod. 18716N**
Mitsuba PMDD
12 Volt, CCW, 9-Spline Shaft

MAKE / MODEL	YEAR
Kawasaki KLF220 Bayou	1988-2002
Kawasaki KLF250 Bayou	2003-2011



◀ **cod. 18718N**
Mitsuba PMDD
12 Volt, CW, 9-Spline Shaft

MAKE / MODEL	YEAR
Arctic Cat DVX 400	2004-2008
Arctic Cat DVX 400 TS	2006-2007
Kawasaki KFX400	2003-2006
Kawasaki KLX400R	2003
Kawasaki KLX400SR	2003
Suzuki DR-Z400	2000-2004
Suzuki DR-Z400E	2000-2007
Suzuki DR-Z400S	2000-2015
Suzuki DR-Z400SM	2005-2015
Suzuki LT-Z400 QuadSport Z	2003-2009



◀ **cod. 18727N**
Mitsuba PMDD
0.6kW/12 Volt, CW, 31-Spline Shaft

MAKE / MODEL	YEAR
Yamaha XV700 Virago	1984-1987
Yamaha XV750 Virago	1981-1997
Yamaha XV920 Virago	1982-1983
Yamaha XV920M Mid-Virago	1983
Yamaha XV920R Seca	1981-1982

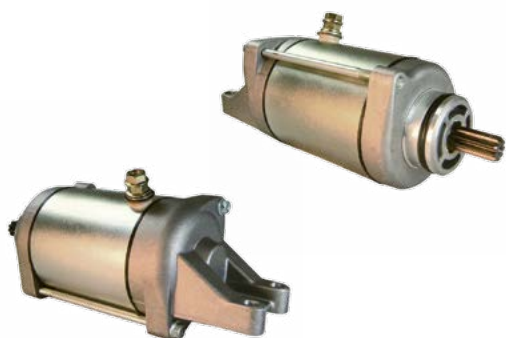

◀ **cod. 18733N**
Mitsuba PMDD
12 Volt, CCW, 9-Tooth Spline

MAKE / MODEL	YEAR
Suzuki GSF1200S Bandit	1997-2006
Suzuki GSX1100G	1991-1993
Suzuki GSX-R1100	1989-1992



◀ **cod. 18734N**
Mitsuba PMDD
12 Volt, CW, 9-Spline Shaft

MAKE / MODEL	YEAR
Yamaha FJ1100	1984-1985
Yamaha FJ1200	1986-1993



◀ **cod. 18737N**
Mitsuba PMDD
12 Volt, CW, 31-Spline Shaft

MAKE / MODEL	YEAR
Yamaha XV1000 Virago	1984-1985
Yamaha XV1100 Virago	1986-1998
Yamaha XV700 Virago	1986-1987
Yamaha XV750 Virago	1990-1997



◀ **cod. 18743N**
Suzuki PMDD
12 Volt, CCW, 9-Tooth Spline

MAKE / MODEL	YEAR
Suzuki GSF400 Bandit	1991-1993
Suzuki GSF600S Bandit	1996-2003
Suzuki GSX600F Katana	1998-2006
Suzuki GSX750F Katana	1998-2006



◀ **cod. 18746N**
Mitsuba PMDD
12 Volt, CW, 22/13-Spline Shaft/Pinion

MAKE / MODEL	YEAR
Yamaha XV1600A Road Star	1999-2003
Yamaha XV1600AS Road Star Midnight	2000
Yamaha XV1600AT Road Star Silverado	1999-2003
Yamaha XV1700AT Road Star Silverado	2006-2007



◀ **cod. 18747N**
Mitsuba PMDD
12 Volt, CCW, 9-Spline Shaft

MAKE / MODEL	YEAR
Suzuki DR250SE	1990-1995
Suzuki DR350S	1990-1993
Suzuki DR350SE	1994-1999
Yamaha TTR225	1999
Yamaha XT225	1992-1999



◀ **cod. 18748N**
Mitsuba PMDD
12 Volt, CW, 13-Tooth Pinion

MAKE / MODEL	YEAR
Yamaha XV1100 Virago	1999
Yamaha XVS1100 V Star 1100 Custom	1999-2009
Yamaha XVS1100A V Star 1100 Classic	2000-2009
Yamaha XVS1100AT V Star 1100 Silverado	2002-2009



◀ **cod. 18749N**
Mitsuba PMDD
12 Volt, CCW, 10-Spline Shaft

MAKE / MODEL	YEAR
Yamaha YJ50 Vino	2001-2004
Yamaha YJ50RA Vino Classic	2002-2005



◀ **cod. 18750N**
Mitsuba PMDD
12 Volt, CW, 9-Spline Shaft

MAKE / MODEL	YEAR
Yamaha VMX1200 V-Max	1985-2000



◀ **cod. 18760N**
Mitsuba PMDD
12 Volt, CW, 12-Tooth Pinion

MAKE / MODEL	YEAR
Aprilia Pegaso 650 Trail	2005-2009
Yamaha YFM660R Raptor	2001-2005



◀ **cod. 18761N**
Mitsuba PMDD
12 Volt, CW, 9-Spline Shaft

MAKE / MODEL	YEAR
Yamaha YFZ450	2004-2013
Yamaha YFZ450 Bill Balance Edition	2006-2007
Yamaha YFZ450 SE	2007-2008

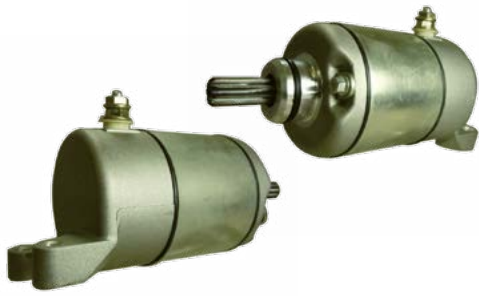

◀ **cod. 18762N**
Mitsuba PMDD
12 Volt, CW, 9-Tooth Pinion

MAKE / MODEL	YEAR
Yamaha TTR250	1999-2006



◀ **cod. 18763N**
Mitsuba PMDD
12 Volt, CCW, 9-SPL

MAKE / MODEL	YEAR
Yamaha FZS600 FZ6	2004-2009
Yamaha YZF-R6	1999-2005
Yamaha YZF-R6S	2006-2009



◀ **cod. 18764N**
Mitsuba PMDD
12 Volt, 9-Tooth Spline

MAKE / MODEL	YEAR
Yamaha FZS1000 FZ1	2001-2005



◀ **cod. 18767N**
Mitsuba PMDD
12 Volt, 12-Tooth Pinion

MAKE / MODEL	YEAR
Yamaha XV1600A Road Star	2003
Yamaha XV1600AS Road Star Midnight	2001-2003
Yamaha XV1700A Road Star	2004-2007
Yamaha XV1700AM Road Star Midnight	2004-2007
Yamaha XV1700AT Road Star Silverado	2004-2005
Yamaha XV1700ATM Road Star Midnight Silverado	2004-2007



◀ **cod. 18768N**
Mitsuba PMDD
12 Volt, CCW, 9-Tooth Spline

MAKE / MODEL	YEAR
Yamaha XV250 Route 66	1988-1990
Yamaha XV250 V Star 250	2008-2015
Yamaha XV250 Virago	1995-2007



◀ **cod. 18769N**
Mitsuba PMDD
12 Volt, CW, 9-Tooth Spline

MAKE / MODEL	YEAR
Yamaha XVZ1300A Royal Star	1996-1998
Yamaha XVZ1300AL Royal Star Boulevard	1999-2001
Yamaha XVZ1300AT Royal Star Tour Classic	1996-2000
Yamaha XVZ1300CT Royal Star Tour Deluxe	1997-2010
Yamaha XVZ1300CTM Royal Star Midnight Tour Deluxe	2006-2007
Yamaha XVZ1300CTS Royal Star Tour Deluxe S	2008-2009
Yamaha XVZ1300TF Royal Star Venture	1999-2009
Yamaha XVZ1300TFM Royal Star Midnight Venture	2002-2007
Yamaha XVZ1300TFS Royal Star Venture S	2009-2013



◀ **cod. 18784N**
Mitsuba PMDD
12 Volt, CW, 9-Spline Shaft

MAKE / MODEL	YEAR
Suzuki GSX-R1100	1993-1998
Suzuki GSX-R600	1992-1993
Suzuki GSX-R750	1993-1995
Suzuki RF600	1994-1996
Suzuki RF900	1994-1997



◀ **cod. 18787N**
Mitsuba PMDD
12 Volt, CW, 9-Tooth Pinion

MAKE / MODEL	YEAR
Suzuki C50 Boulevard	2005-2013
Suzuki C50 Boulevard B.O.S.S.	2014
Suzuki C50 Boulevard SE	2009-2013
Suzuki C50B Boulevard	2005-2008
Suzuki C50C Boulevard	2006-2008
Suzuki C50T Boulevard	2005-2013

◀ **cod. 18787N** - continued

MAKE / MODEL	YEAR
Suzuki CS0T Boulevard Classic	2012
Suzuki M50 Boulevard	2005-2013
Suzuki M50 Boulevard Limited	2007
Suzuki M50 Boulevard SE	2009
Suzuki M50B Boulevard	2005-2006
Suzuki S50 Boulevard	2005-2009
Suzuki VL800	2013-2015
Suzuki VL800 Intruder Volusia	2001-2004
Suzuki VS700 Intruder	1985-1987
Suzuki VS750GL Intruder	1988-1991
Suzuki VS800GL Intruder	1992-2008
Suzuki VX800	1990-1993
Suzuki VZ800	2013
Suzuki VZ800 Marauder	2005-2008



◀ **cod. 18788N**

Denso PMDD
0.6kW/12 Volt, CCW, 10-Tooth Spline

MAKE / MODEL	YEAR
Kawasaki ZX900 Ninja ZX-9R	1998-2003
Suzuki GS500	1989-2002
Suzuki GS500F	2004-2009
Suzuki GSX750F Katana	1989-1997
Suzuki GSX-R750	1988-1992



◀ **cod. 18791N**

Mitsuba PMDD
12 Volt, CCW, 9-Tooth Spline

MAKE / MODEL	YEAR
Suzuki GSX-R600	1997-2000



◀ **cod. 18792N**

Mitsuba PMDD
12 Volt, CCW, 9-Tooth Spline

MAKE / MODEL	YEAR
Suzuki GSX-R750	1996-1999



◀ **cod. 18798N**
Denso PMDD
12 Volt, CCW, 9-Spline Shaft

MAKE / MODEL	YEAR
Suzuki GSX1300R Hayabusa	1999-2003



◀ **cod. 18814N**
Denso PMDD
12 Volt, CCW, 9-Spline Shaft

MAKE / MODEL	YEAR
Suzuki GSX1300R Hayabusa	1999-2007
Suzuki GSX1300R Hayabusa Limited Edition	2006



◀ **cod. 18820N**
Denso PMDD
12 Volt, CCW, 9-Spline Shaft

MAKE / MODEL	YEAR
Aprilia Pegaso 650	1992-2004
BMW F650	1993-2000
BMW F650 Enduro	1998-2001
BMW F650 Funduro	1993-1997
BMW F650 SE	1999
BMW F650CS	2000-2006
BMW F650CS ABS	2003-2005
BMW F650GS	1999-2012
BMW F650GS ABS	2001-2005
BMW F650GS Dakar	2001-2007
BMW F650GS Dakar ABS	2002-2005
BMW F650GS Dakota	2000-2007
BMW F650ST	1997-1999
BMW F700GS	2011-2014
BMW F800GS	2008-2014
BMW F800GS Adventure	2012-2014
BMW F800GT	2011-2014
BMW F800R	2005-2014
BMW F800S	2006-2008
BMW F800ST	2006-2012
Bombardier DS650	2000-2007
Bombardier DS650 Baja	2001-2004
Bombardier DS650 X	2004-2007
Can-Am DS 650 X	2007



◀ **cod. 18825N**
Mitsuba PMDD
12 Volt, CW, 9-Tooth Spline

MAKE / MODEL	YEAR
Yamaha VMX1200 V-Max	2001-2007



◀ **cod. 18833N**
Mitsuba PMDD
12 Volt, CW, 9-Tooth Spline

MAKE / MODEL	YEAR
Kawasaki ZX600 Ninja ZX6-RR	2003-2006
Kawasaki ZX636 Ninja ZX-6R	2003-2006



◀ **cod. 18836N**
Mitsuba PMDD
12 Volt, 10-Tooth Spline

MAKE / MODEL	YEAR
Kawasaki ZX1000 Ninja ZX-10R	2004-2006



◀ **cod. 18837N**
Mitsuba PMDD
12 Volt, CCW, 9-Tooth Spline

MAKE / MODEL	YEAR
Kawasaki VN2000A Vulcan 2000	2004-2009
Kawasaki VN2000D Vulcan 2000 Limited	2005-2006
Kawasaki VN2000E Vulcan 2000 Classic	2006-2009
Kawasaki VN2000F Vulcan 2000 Classic LT	2006-2010



◀ **cod. 18843N**
Mitsuba PMDD
12 Volt, CW, 9-Tooth Spline

MAKE / MODEL	YEAR
Yamaha CP250 Morphous	2006-2008
Yamaha YP400 Majesty	2005-2012



◀ **cod. 18844N**
Mitsuba PMDD
12 Volt, CW, 9-Tooth Spline

MAKE / MODEL	YEAR
Yamaha WR450F	2003-2006



◀ **cod. 18845N**
Mitsuba PMDD
12 Volt, CCW, 9-Tooth Spline

MAKE / MODEL	YEAR
Yamaha TT225	1986-1987
Yamaha TTR225	1999-2004
Yamaha XT225	2000-2002



◀ **cod. 18850N**
Mitsuba PMDD
12 Volt, CW, 9-Tooth Pinion

MAKE / MODEL	YEAR
Honda CRF230F	2003-2009



◀ **cod. 18851N**
Mitsuba PMDD
12 Volt, CCW, 9-Spline Shaft

MAKE / MODEL	YEAR
Honda CRF250X	2004-2015



◀ **cod. 18852N**
Mitsuba PMDD
12 Volt, CW, 9-Tooth Spline

MAKE / MODEL	YEAR
Honda CRF450X	2005-2015



◀ **cod. 18859N**
Mitsuba PMDD
12 Volt, CCW, 9-Spline Shaft

MAKE / MODEL	YEAR
Honda FSC600 Silver Wing	2002-2010
Honda FSC600A Silver Wing ABS	2003-2013



◀ **cod. 18886N**
Denso PMDD
0.7kW/ 2 Volt, CW, 9-Tooth Pinion

MAKE / MODEL	YEAR
Suzuki AN400 Burgman	2003-2012
Suzuki AN400 Burgman ABS	2009-2013
Suzuki AN400S Burgman Type S	2003-2006
Suzuki AN650A Burgman ABS	2013



◀ **cod. 18905BN**
Mitsuba PMDD
1.4kW/12 Volt, 10-Tooth Pinion

MAKE / MODEL	YEAR
Harley Davidson FLHR Road King	2007
Harley Davidson FLHRC Road King Classic	2007
Harley Davidson FLHRCI Road King Classic	2007
Harley Davidson FLHRI Road King	2007
Harley Davidson FLHRS Road King Custom	2007
Harley Davidson FLHRSE3 Screamin Eagle Road King	2007
Harley Davidson FLHRSE4 Screamin Eagle Road King	2008
Harley Davidson FLHRSE5 CVO Road King	2013
Harley Davidson FLHT Electra Glide Standard	2007
Harley Davidson FLHTC Electra Glide Classic	2007

◀ **cod. 18905BN** - continued

MAKE / MODEL	YEAR
Harley Davidson FLHTCI Electra Glide Classic	2007
Harley Davidson FLHTCUSE2 Screamin Eagle Ultra Classic Electra Gli	2007
Harley Davidson FLHTCUSE3 Screamin Eagle Ultra Classic Electra Gli	2008
Harley Davidson FLHTCUSE4 CVO Ultra Classic Electra Glide	2009
Harley Davidson FLHTCUSE5 CVO Ultra Classic Electra Glide	2010
Harley Davidson FLHTCUSE6 CVO Ultra Classic Electra Glide	2011
Harley Davidson FLHTCUSE7 CVO Ultra Classic Electra Glide	2012
Harley Davidson FLHTCUSE8 CVO Ultra Classic Electra Glide	2013
Harley Davidson FLHTI Electra Glide Standard	2007
Harley Davidson FLHX Street Glide	2007
Harley Davidson FLHXSE CVO Street Glide	2010
Harley Davidson FLHXSE2 CVO Street Glide	2011-2012
Harley Davidson FLHXSE3 CVO Street Glide	2012
Harley Davidson FLSTC Heritage Softail Classic	2007
Harley Davidson FLSTCI Heritage Softail Classic	2007
Harley Davidson FLSTF Fat Boy	2007-2013
Harley Davidson FLSTN Softail Deluxe	2007-2013
Harley Davidson FLSTSC Softail Springer Classic	2007
Harley Davidson FLSTSE CVO Softail Convertible	2010
Harley Davidson FLSTSE2 CVO Softail Convertible	2011-2012
Harley Davidson FLSTSE3 CVO Softail Convertible	2012
Harley Davidson FLTR Road Glide	2007
Harley Davidson FLTRSE3 CVO Road Glide	2009
Harley Davidson FLTRUSE CVO Road Glide Ultra	2011
Harley Davidson FXD Dyna Super Glide	2007
Harley Davidson FXDFSE CVO Dyna Fat Bob	2009
Harley Davidson FXDFSE2 CVO Dyna Fat Bob	2010
Harley Davidson FXDL Dyna Low Rider	2007
Harley Davidson FXDSE Screamin Eagle Dyna	2007
Harley Davidson FXDSE2 Screamin Eagle Dyna	2008
Harley Davidson FXDWG Dyna Wide Glide	2007
Harley Davidson FXSBSE CVO Breakout	2013
Harley Davidson FXST Softail Standard	2007
Harley Davidson FXSTB Night Train	2007
Harley Davidson FXSTC Softail Custom	2007
Harley Davidson FXSTD Softail Deuce	2007
Harley Davidson FXSTSSE Screamin Eagle Softail Springer	2007
Harley Davidson FXSTSSE2 Screamin Eagle Softail Springer	2008
Harley Davidson FXSTSSE3 CVO Softail Springer	2009



◀ **cod. 18905CN**
Denso OSGR
1.4kW/12 Volt, 10-Tooth Pinion, Chrome

MAKE / MODEL	YEAR
Harley Davidson FLHR Road King	2007
Harley Davidson FLHRC Road King Classic	2007
Harley Davidson FLHRCI Road King Classic	2007
Harley Davidson FLHRI Road King	2007
Harley Davidson FLHRS Road King Custom	2007
Harley Davidson FLHRSE3 Screamin Eagle Road King	2007
Harley Davidson FLHRSE4 Screamin Eagle Road King	2008

◀ cod. **18905CN** - continued

MAKE / MODEL	YEAR
Harley Davidson FLHT Electra Glide Standard	2007
Harley Davidson FLHTC Electra Glide Classic	2007
Harley Davidson FLHTCI Electra Glide Classic	2007
Harley Davidson FLHTCUSE2 Screamin Eagle Ultra Classic Electra Gli	2007
Harley Davidson FLHTCUSE3 Screamin Eagle Ultra Classic Electra Gli	2008
Harley Davidson FLHTCUSE4 CVO Ultra Classic Electra Glide	2009
Harley Davidson FLHTCUSE5 CVO Ultra Classic Electra Glide	2010
Harley Davidson FLHTCUSE6 CVO Ultra Classic Electra Glide	2011
Harley Davidson FLHTCUSE7 CVO Ultra Classic Electra Glide	2012
Harley Davidson FLHTCUSE8 CVO Ultra Classic Electra Glide	2013
Harley Davidson FLHTI Electra Glide Standard	2007
Harley Davidson FLHX Street Glide	2007
Harley Davidson FLHXSE CVO Street Glide	2010
Harley Davidson FLHXSE2 CVO Street Glide	2011-2012
Harley Davidson FLHXSE3 CVO Street Glide	2012
Harley Davidson FLSTC Heritage Softail Classic	2007
Harley Davidson FLSTCI Heritage Softail Classic	2007
Harley Davidson FLSTF Fat Boy	2007-2013
Harley Davidson FLSTN Softail Deluxe	2007-2013
Harley Davidson FLSTSC Softail Springer Classic	2007
Harley Davidson FLTSE CVO Softail Convertible	2010
Harley Davidson FLTSE2 CVO Softail Convertible	2011-2012
Harley Davidson FLTSE3 CVO Softail Convertible	2012
Harley Davidson FLTR Road Glide	2007
Harley Davidson FLTRSE3 CVO Road Glide	2009
Harley Davidson FLTRUSE CVO Road Glide Ultra	2011
Harley Davidson FXD Dyna Super Glide	2007
Harley Davidson FXDFSE CVO Dyna Fat Bob	2009
Harley Davidson FXDFSE2 CVO Dyna Fat Bob	2010
Harley Davidson FXDL Dyna Low Rider	2007
Harley Davidson FXDSE Screamin Eagle Dyna	2007
Harley Davidson FXDSE2 Screamin Eagle Dyna	2008
Harley Davidson FXDWG Dyna Wide Glide	2007
Harley Davidson FXST Softail Standard	2007
Harley Davidson FXSTB Night Train	2007
Harley Davidson FXSTC Softail Custom	2007
Harley Davidson FXSTD Softail Deuce	2007
Harley Davidson FXSTSSE Screamin Eagle Softail Springer	2007
Harley Davidson FXSTSSE2 Screamin Eagle Softail Springer	2008
Harley Davidson FXSTSSE3 CVO Softail Springer	2009



◀ cod. **18915N**

Valeo PMGR
1.2kW/12 Volt, CW, 9-Tooth Pinion

MAKE / MODEL	YEAR
BMW R100	1976-1984
BMW R100/7	1976-1978
BMW R100CS	1980-1984
BMW R100GS	1987-1995
BMW R100GS Paris-Dakar	1987-1995
BMW R100R	1991-1995

◀ cod. **18915N** - continued

MAKE / MODEL	YEAR
BMW R100R Mystic	1994-1995
BMW R100RS	1976-1993
BMW R100RT	1978-1995
BMW R100RT Classic	1995-1996
BMW R100S	1976-1980
BMW R100T	1978-1984
BMW R45	1978-1985
BMW R45N	1978-1985
BMW R45T	1985-1980
BMW R45TN	1985-1980
BMW R50/5	1969-1973
BMW R60/6	1973-1976
BMW R60/7	1976-1980
BMW R65	1978-1987
BMW R65LS	1981-1985
BMW R65T	1981-1985
BMW R75/5	1969-1980
BMW R75/6	1974-1976
BMW R75/7	1976-1977
BMW R80	1984-1995
BMW R80/7	1976-1980
BMW R80G/S	1980-1996
BMW R80R	1991-1994
BMW R80RT	1982-1995
BMW R80ST	1982-1984
BMW R90/6	1973-1976
BMW R90S	1973-1976



◀ cod. **19091N**
Denso PMDD
12 Volt, CCW, 9-Tooth Pinion

MAKE / MODEL	YEAR
KTM 250 XC	2009-2014
KTM 250 XC-W	2008-2014
KTM 300 XC	2008-2014
KTM 300 XC-W	2008-2014



◀ cod. **19162N**
Mitsubishi PMGR
1.2kW/12 Volt, CW, 8-Tooth Pinion

MAKE / MODEL	YEAR
Bobcat 2200S (Diesel)	2004-2006
Husqvarna HUV-4421-DXP	2006-2010



◀ **cod. 19200N**
Mitsuba PMDD
12 Volt, CW, 9-Tooth Pinion

MAKE / MODEL	YEAR
Yamaha YFZ450R	2009-2015
Yamaha YFZ450R SE	2009-2015
Yamaha YFZ450X	2011-2010
Yamaha YFZ450X Bill Balance	2010
Yamaha YFZ450X SE	2011

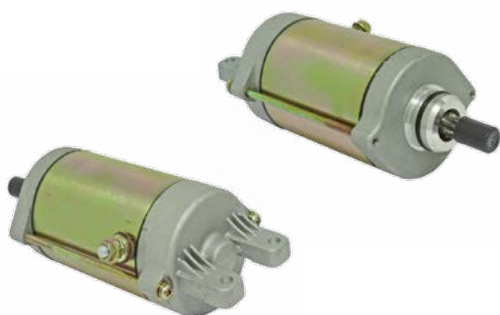

◀ **cod. 19228N**
China (Made) PMDD
12 Volt, CW, 9-Tooth Spline

MAKE / MODEL	YEAR
Kymco MXU500	2006-2009
Kymco MXU500 4x4 IRS	2012-2014
Kymco MXU500 IRS	2011-2010
Kymco MXU500i 4x4 IRS	2012-2014
Kymco MXU500i 4x4 IRS LE	2012-2014
Kymco UXV 500 4X4 SE	2011
Kymco UXV 500i 4X4	2012-2014
Kymco UXV 500i HE	2014
Kymco UXV 500i LE	2012-2014
Kymco UXV 500i SE	2012-2013
Kymco UXV 500i SP	2011-2013
Kymco UXV 500i TURF	2014
Kymco Xciting 500	2005-2008
Kymco Xciting 500Ri	2009-2012
Kymco Xciting 500Ri ABS	2009-2014



◀ **cod. 19571N**
China (Made) PMDD
12 Volt, CW, 9-Tooth Pinion

MAKE / MODEL	YEAR
Aprilia Scarabeo 125	1999-2005
Aprilia Scarabeo 150	1999-2004
BMW C1 125	1999-2003

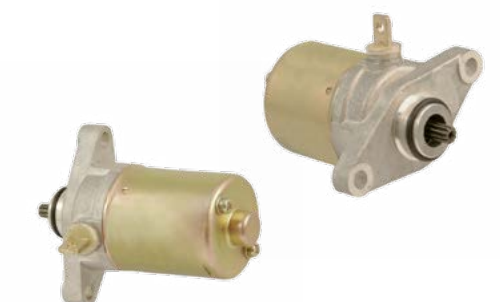

◀ **cod. 19587N**
China (Made) PMDD
12 Volt, CCW, 9-Tooth Pinion

MAKE / MODEL	YEAR
China Built ATV's & Scooters	All
Yamaha YBR125	All



◀ **cod. 19588N**
Mitsuba PMDD
12 Volt, CCW, 9-Tooth Pinion

MAKE / MODEL	YEAR
Aprilia Atlantic 125	2003-2013
Aprilia Atlantic 200	2003-2006
Aprilia Mojito 125	2003-2010
Aprilia Mojito 150	2003-2007
Aprilia Scarabeo 125 Euro	2003-2007
Aprilia Scarabeo 200GT	2003-2006
Aprilia Sportcity 125 Euro	2004-2009
Aprilia Sportcity Cube 200	2008-2010
Aprilia Sportcity Cube 200 Euro	2004-2009
Aprilia Sportcity One 125	2008-2010
Aprilia SR 125	2012-2013
Benelli Adiva 125	2001-2006
Benelli Adiva 150	2001-2006

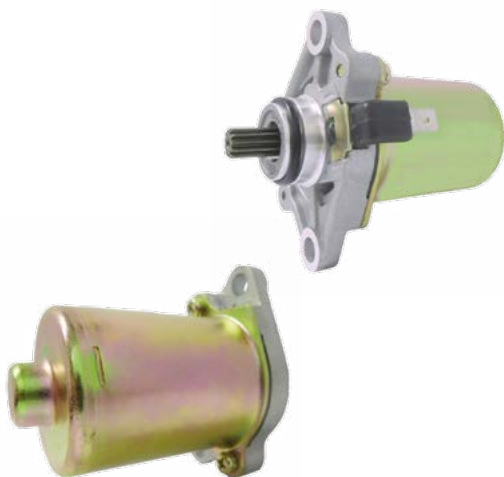

◀ **cod. 19595N**
Chinese PMDD
12 Volt, CCW, 11-Tooth Pinion

MAKE / MODEL	YEAR
Aprilia Mojito Custom 50	2004-2008
Aprilia Scarabeo 50 2T	2005-2013
Aprilia Scarabeo 50 2T E2	2006-2008
Aprilia Sportcity One 50	2008-2013
Aprilia SR 50	2003-2008
Aprilia SR 50 IE	2003-2008
Aprilia SR 50 R Factory	2005-2013
Aprilia SR50R Factory	2006-2013
Honda SA50 Elite LX	1988-1990
Honda SA50 Elite SR	1988-1993
Kymco CX50	1993-1997
Kymco DJ50	1993-2006
Kymco DJW 50 World	1995-1997
Kymco DJX50	1991-1992
Kymco K12 Sport 50	1995-2006
Kymco KB50	1995-2000



◀ **cod. 19597N**
Chinese PMDD
12 Volt, CCW, 10-Tooth Pinion

MAKE / MODEL	YEAR
GMI GMI 101	2004-2008
GMI GMI 102	2004-2008
GMI GMI 102P	2004-2008
GMI GMI 103	2004-2008
GMI GMI 104	2004-2008
GMI GMI 106	2004-2008
GMI GMI 106I	2004-2008

◀ **cod. 19597N** - continued

MAKE / MODEL	YEAR
GMI GMI 107	2004-2008
GMI GMI 107XP	2004-2008
GMI GMI 108	2004-2008
GMI GMI 109	2004-2008
GMI GMI 110	2005-2008
GMI GMI 111	2004-2008
GMI GMI 301	2004-2008
GMI GMI 304	2004-2008
Kymco Mongoose 50	2004-2009
Kymco Mongoose 70	2007-2010
Kymco Sting 50	2009-2011
Kymco Super 9	2002-2009
Kymco Vitality 50	2004-2007
Kymco Yup 50	2002-2003

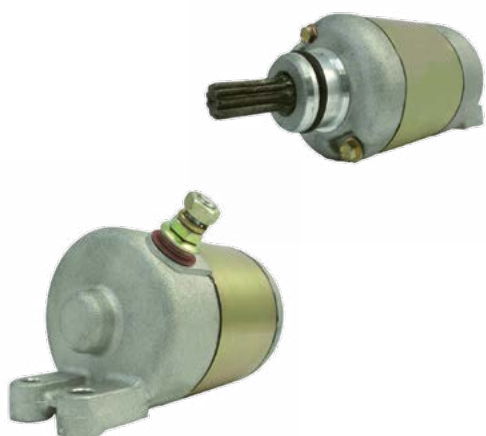

◀ **cod. 19620N**
Mitsuba PMDD
 12 Volt, CCW, 9-Tooth Pinion

MAKE / MODEL	YEAR
KTM 400 EXC	2000-2006
KTM 400 MXC	2001-2002
KTM 400 SX	2000-2002
KTM 400 XC-W	2007-2010
KTM 450 EXC	2003-2005
KTM 450 EXC-R	2008-2011
KTM 450 MXC	2003-2005
KTM 450 SMR	2005-2006
KTM 450 SMS	2004
KTM 450 SX-F	2003-2006
KTM 450 SXS	2003-2006
KTM 450 XC	2008-2010
KTM 450 XC-F	2006
KTM 450 XC-W	2006-2011
KTM 520 EXC	2000-2002
KTM 520 MXC	2000-2002
KTM 520 SX	2000-2002
KTM 525 EXC	2003-2006
KTM 525 EXC-G	2006-2007
KTM 525 MXC	2003-2005
KTM 525 SMR	2004-2006
KTM 525 SX	2003-2006
KTM 525 XC	2008-2010
KTM 525 XC-G	2006-2007
KTM 525 XC-W	2007
KTM 530 EXC-R	2008-2011
KTM 530 XC-W	2008-2011
KTM 540 SXC	2000-2006
Polaris Outlaw 450 MXR	2008-2010
Polaris Outlaw 525 IRS	2007-2011
Polaris Outlaw 525 S	2008-2010



◀ **cod. 19628N**
China (Made) PMGR
12 Volt, CW, 9-Tooth Pinion

MAKE / MODEL	YEAR
Aprilia Classic 125	2000-2005
Aprilia Extreme 125	2001-2005
Aprilia Replica 125	2001-2005
Aprilia RS 125	1996-2005
Aprilia Tuono 125	2003-2005



◀ **cod. 19633N**
Mitsuba PMDD
12 Volt, CCW, 9-Tooth Pinion

MAKE / MODEL	YEAR
KTM 400 LC4	1998-2001
KTM 400 LSE	1997-1998
KTM 400 RXC	1996-1998
KTM 400 TXC	1998
KTM 620 Comp Limited	1997
KTM 620 Duke	1996-1997
KTM 620 EGS	1994-1997
KTM 620 EGS-E	1997
KTM 620 EXC	1994-1997
KTM 620 LC4 EXC	1994-1997
KTM 620 LC4 SX	1997-1998
KTM 620 RXC	1995-1998
KTM 620 SC	1994-2001
KTM 620 Super Moto	1998-2001
KTM 620 SX	1996-1999
KTM 620 SXC	1997
KTM 620 TXC	1998
KTM 625 SMC	2004-2006
KTM 625 SXC	2003-2004
KTM 640 Adventure	1998-2008
KTM 640 Duke	1998
KTM 640 Duke II	1999-2006
KTM 640 Enduro	1999-2002
KTM 640 Supermoto	1999-2005
KTM 660 Rally	2000-2006
KTM 660 SMC	2002-2006
KTM 660 SMS	2004



◀ **cod. 19639N**
Mitsuba PMDD
12 Volt, CW, 9-Tooth Pinion

MAKE / MODEL	YEAR
Yamaha XT250	2008-2015
Yamaha YFM250 Raptor	2008-2013
Yamaha YFM250 Raptor SE	2008
Yamaha YFM250 Raptor SE Custom	2008
Yamaha YFM250R Raptor	2011



◀ **cod. 19643N**
Mitsuba PMDD
12 Volt, CW, 10-Tooth Pinion

MAKE / MODEL	YEAR
Honda NSA700 DN-01	2009
Honda NT700V	2011-2010
Honda NT700VA ABS	2011-2010
Honda VT750C Shadow Aero	2008-2015
Honda VT750C2 Shadow Spirit	2007-2015
Honda VT750C2 Shadow Spirit ABS	2011-2013
Honda VT750C2B Shadow Phantom	2012-2015
Honda VT750CA Shadow Aero ABS	2012-2014
Honda VT750RS Shadow RS	2013



◀ **cod. 19646N**
Denso PMDD
12 Volt, CW, 9-Tooth Pinion

MAKE / MODEL	YEAR
BMW K1200GT	2005-2008
BMW K1200R	2004-2008
BMW K1200R Sport	2005-2008
BMW K1200S	2003-2008
BMW K1300GT	2007-2010
BMW K1300R	2007-2012
BMW K1300S	2007-2015
BMW K1600GT	2010-2015
BMW K1600GTL	2010-2015
BMW K1600GTL EXCL	2011-2013



◀ **cod. 19876N**
Denso PMDD
0.7kW/12 Volt, CCW, 15-Tooth Pinion

MAKE / MODEL	YEAR
Ducati 748	2000-2003
Ducati 749	2003-2006
Ducati 750	1999-2002
Ducati 800	2003-2004
Ducati 900	1997-2002
Ducati 996	2002
Ducati 999	2003-2006
Ducati 1000	2003-2005
Ducati 1098	2007-2008
Ducati 1000DS	2005-2006
Ducati 1098 S	2007-2008
Ducati 1098 S Tricolore	2007

 **cod. 19876N** - continued

MAKE / MODEL	YEAR
Ducati 620 Sport	2003
Ducati 748 Monoposto	2001-2002
Ducati 748R	2000-2002
Ducati 748R Biposto	2002
Ducati 748S	2000-2002
Ducati 748S Monoposto	2001-2002
Ducati 749 Dark	2004-2006
Ducati 749R	2004-2006
Ducati 749S	2003-2006
Ducati 750 Sport	2001-2002
Ducati 800 Sport	2003
Ducati 900 Sport	2002
Ducati 916 SP	1995
Ducati 916 SPS	1997-1998
Ducati 996 Biposto	2001
Ducati 996 Monoposto	2001
Ducati 996 SPS	1999-2000
Ducati 996R	2001
Ducati 996S	2001-2003
Ducati 996S Monoposto	2001
Ducati 998 Biposto	2002-2003
Ducati 998 F Edition Biposto	2004
Ducati 998 F Edition Monoposto	2004
Ducati 998 Matrix	2004
Ducati 998 Monoposto	2002-2004
Ducati 998R	2002
Ducati 998S	2002
Ducati 998S Bayliss	2002
Ducati 998S Bostrom	2002
Ducati 998S Monoposto	2002
Ducati 999R	2003-2006
Ducati 999R FILA	2003-2004
Ducati 999R Xerox	2006
Ducati 999S	2003-2006
Ducati GT1000	2007-2010
Ducati GT1000 Touring	2009
Ducati MH900e	2001-2002
Ducati Monster 1000	2004-2005
Ducati Monster 1000 Dark	2003
Ducati Monster 1000s	2003-2005
Ducati Monster 400	2001-2005
Ducati Monster 400 Dark	2002-2004
Ducati Monster 400 Metallic	2001
Ducati Monster 400s	2003
Ducati Monster 600	2000-2001
Ducati Monster 600 Dark	2001
Ducati Monster 600 Metallic	2001
Ducati Monster 620	2002-2006
Ducati Monster 620 Capirex	2004
Ducati Monster 620 Dark	2005-2006
Ducati Monster 620 Matrix	2004
Ducati Monster 620s	2002-2003
Ducati Monster 695	2007-2008
Ducati Monster 696	2008-2009

◀ cod. **19876N** - continued

MAKE / MODEL	YEAR
Ducati Monster 750	2000-2002
Ducati Monster 750 Dark	2001-2002
Ducati Monster 750 Metallic	2001-2002
Ducati Monster 800	2004
Ducati Monster 800 Dark	2003
Ducati Monster 800s	2003
Ducati Monster 900	2000-2002
Ducati Monster 900 Cromo	2001
Ducati Monster 900 Dark	2001-2002
Ducati Monster 900 Metallic	2001
Ducati Monster 900s	2000-2001
Ducati Monster S2R	2005-2006
Ducati Monster S2R 1000	2006-2008
Ducati Monster S2R 800	2007
Ducati Monster S2R Dark	2005-2006
Ducati Monster S4	2001-2002
Ducati Monster S4 Fogarty	2002
Ducati Monster S4R	2003-2007
Ducati Monster S4R Testastretta	2007-2008
Ducati Monster S4Rs	2006
Ducati Monster S4Rs Testastretta	2006-2008
Ducati Monster S4Rs Tricolore	2008
Ducati Multistrada 1000	2003-2005
Ducati Multistrada 1000 DS	2005-2006
Ducati Multistrada 1000s DS	2005-2006
Ducati Multistrada 1100	2007-2008
Ducati Multistrada 1100 S	2007-2009
Ducati Multistrada 620	2005-2006
Ducati Multistrada 620 Dark	2005-2006
Ducati PaulSmart 1000 LE	2005-2006
Ducati Sport 1000	2006
Ducati Sport 1000 Biposto	2007-2008
Ducati Sport 1000 Monoposto	2007
Ducati Sport 1000s	2007-2008
Ducati ST2	2000-2003
Ducati ST3	2004-2007
Ducati ST3S ABS	2006-2007
Ducati ST4	2000-2004
Ducati ST4S	2001-2005
Ducati ST4S ABS	2005



◀ cod. **37009N**
China (Made) PMDD
12 Volt, CW



MAKE / MODEL	YEAR
Kymco Bet & Win 250	2002-2004
Kymco Grandvista 250	2004-2011
Kymco People 250	2004-2007
Kymco People S 250	2006-2011
Kymco Xciting 250	2006-2011

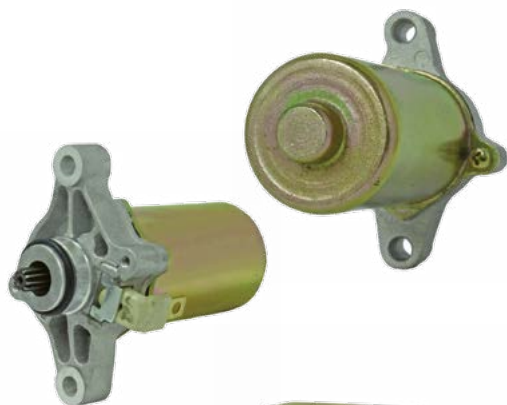

◀ **cod. 37010N**
China (Made) PMDD
12 Volt, CCW

MAKE / MODEL	YEAR
Kymco Cobra 50	2001-2003
Kymco Cobra Cross	2002-2003
Kymco Compagno 50i	2011-2013
Kymco People 50	2001-2012



◀ **cod. 37033N**
China (Made) PMDD
12 Volt, CCW, 9-Tooth Pinion

MAKE / MODEL	YEAR
Aprilia Habana 125	1999-2003
Aprilia Mojito 125	1993-2003
Piaggio Hexagon LX4 125	1999-2003
Piaggio Liberty 125	1999-2003
Piaggio Sfera 125	1999-2003
Piaggio Vespa ET4	1999-2003



◀ **cod. 37034N**
China (Made) PMDD
12 Volt, CCW, 11-Tooth Pinion

MAKE / MODEL	YEAR
Piaggio APE 50	All
Piaggio PK125	All
Piaggio PK50	All

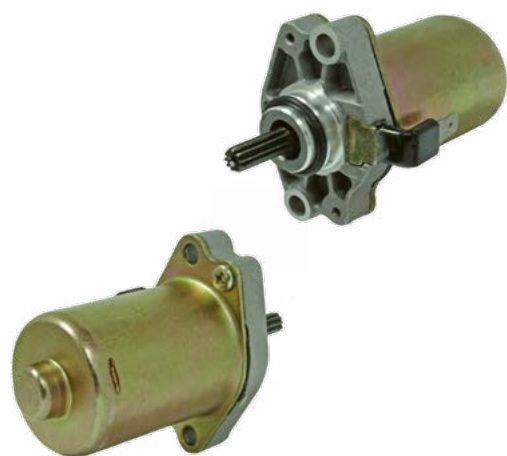

◀ **cod. 37036N**
China (Made) PMDD
12 Volt, CCW, 10-Tooth Pinion

MAKE / MODEL	YEAR
Aprilia Habana 50	1999-2003
Aprilia Mojito Custom 50	1999-2004
Aprilia Mojito Retro 50	1999-2003
Aprilia Scarabeo 50 Ditech	2001-2006
Aprilia SR 50 Ditech	2002-2004
Aprilia SR 50 R Factory	2005-2013
Atala Byte AT 1050	1997-1998
Atala Hacker AT12.50	1998-1999
Atala Hacker LC 50	1997-1998
Atala Hacker Racing 50	1997-1999
Atala Skeggia 50	1998-1999
Benelli 491 RR SBK	2003-2004
Benelli 491 Sport	2003-2004
Benelli 491 ST Rage	2003-2004
Benelli Naked Morini 50	2003
Suzuki AP50	1996-1997
Suzuki TR50 Street Magic	1998-1999



◀ **cod. 37039N**
Mitsuba PMDD
12 Volt

MAKE / MODEL	YEAR
Yamaha XP500 TMAX	2009-2015



◀ **cod. 37042N**
China (Made) PMDD
12 Volt

MAKE / MODEL	YEAR
Sym GTS 125	2006-2008
Sym Joy-Max 300	2006-2008
Sym Voyager 125	2007-2008

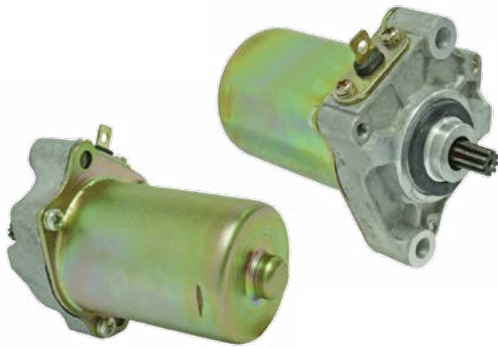

◀ **cod. 37044N**
China (Made) PMDD
12 Volt, CCW, 9-Tooth Pinion

MAKE / MODEL	YEAR
Honda SH 100	2000-2008
Honda Shadow 50	2010-2013
Honda Shadow 90	2010-2013

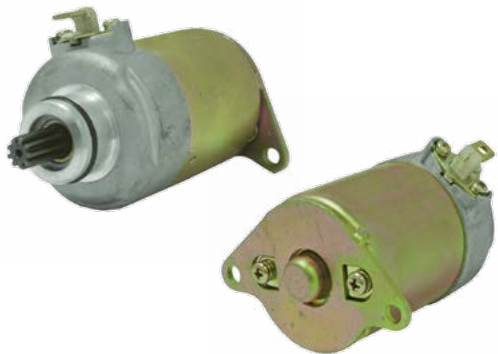

◀ **cod. 37045N**
China (Made) PMDD
12 Volt

MAKE / MODEL	YEAR
Kymco Eruo 2	2001-2009
Kymco Eruo 3	2001-2009
Kymco Gran Dink 125	2001-2009
Kymco Gran Dink 150	2001-2009



◀ **cod. 37046N**
Mitsuba PMDD
12 Volt, CW, 9-Tooth Pinion

MAKE / MODEL	YEAR
Honda SH 125	2001-2008
Honda SH 150	2001-2008



NOVITÀ

◀ **cod. DERSR0007**
Serie paraoli motore

APPLICABILITÀ

APRILIA RS 50 2T 06-10, RS4 50 2T 11-13, RS4 REPLICA 50 2T 14-16, RX 50 2T 06-10, RX 50 2T 14-16, SX 50 2T 06-16, SX LIMITED EDITION 50 2T 14-16

CAGIVA MITO 50 2T 98-99

DERBI GPR 2T 50 2T 13-13, GPR 2T EU2 50 2T 09-10, GPR NUDE 50 2T 04-05, GPR NUDE & GPR NUDE TUNING 50 2T 06-08, GPR NUDE SPORT 50 2T 06-06, GPR R 50 2T 97-00, GPR R EU2 - GPR REPLICA EU2 50 2T 08-08, GPR RACING 50 2T 04-05, GPR RACING EU2 50 2T 06-06, GPR REPLICA 50 2T 99-01, GPR REPLICA & GPR R EU2 50 2T 06-06, GPR REPLICA 2T MALOSSÌ 50 2T 07-07, GPR REPLICA PESEK EU2 50 2T 07-07, GPR REPLICA RACING 50 2T 02-03, GPR REPLICA RACING EU2 50 2T 05-05, SENDA BLACK EDITION 50 2T 03-03, SENDA HYP DRD EVO EU2 50 2T 08-09, SENDA HYP DRD EVO LIMITED EDITION EU2 50 2T 08-08, SENDA R 50 2T 99-01, SENDA R DRD BLACK DEVIL 2A EDIZIONE 50 2T 03-03, SENDA R DRD EU1 EU1R 50 2T 02-02, SENDA R DRD PRO EU2 50 2T 05-11, SENDA R DRD RACING 50 2T 04-05, SENDA R DRD RACING EU2 50 2T 05-08, SENDA R DRD RACING LTD 50 2T 05-05, SENDA R DRD X-TREME 2T EU2 50 2T 14-15, SENDA R DRD X-TREME 2T EURO2 50 2T 10-12, SENDA R RACER 50 2T 03-03, SENDA R X-RACE 50 2T 04-05, SENDA R X-RACE 2T EU2 50 2T 10-10, SENDA R X-RACE EU2 50 2T 06-09, SENDA R X-TREME 50 2T 03-03, SENDA R X-TREME 50 2T 05-05, SENDA R X-TREME 2T EU2 50 2T 10-10, SENDA R X-TREME EU2 50 2T 04-08, SENDA SM 50 2T 00-01, SENDA SM DRD EDITION BLACK 50 2T 05-05, SENDA SM DRD EU1 EU1R 50 2T 02-03, SENDA SM DRD PRO EU2 50 2T 05-11, SENDA SM DRD PRO EU2 2VER 50 2T 05-08, SENDA SM DRD RACING 50 2T 04-05, SENDA SM DRD RACING EU2 50 2T 05-08, SENDA SM DRD RACING EU2 50 2T 10-13, SENDA SM DRD RACING LTD 50 2T 05-05, SENDA SM DRD RACING LTD EU2 50 2T 07-07, SENDA SM DRD X-TREME 2T EU2 50 2T 14-15, SENDA SM DRD X-TREME 2T EU2 LIMITED ED 50 2T 14-15, SENDA SM X-RACE 50 2T 04-05, SENDA SM X-RACE 2T EU2 50 2T 10-10, SENDA SM X-RACE EU2 50 2T 06-09, SENDA SM X-RACE EU2 2VER 50 2T 07-09, SENDA SM X-TREME 50 2T 02-03, SENDA SM X-TREME 2T EU2 50 2T 10-10, SENDA SM X-TREME EU2 50 2T 04-08, SENDA SM X-TREME EU2 2A EDIZIONE 50 2T 05-05

GILERA GSM 50 2T 01-01, RCR 50 2T 03-03, RCR 50 2T 06-07, RCR 50 2T 11-13, RCR (CHE-SYC) 50 2T 13-15, SMT 50 2T 03-13, SMT RACING 50 2T 11-12

VALENTI RACING RME 50 2T 15-17, SM 50 2T 15-17



NOVITÀ

◀ **cod. MINSRA0022**
Serie paraoli motore

APPLICABILITÀ

APRILIA CLASSIC 50 2T 92-99, MX 50 2T 04-04, RS 50 2T 91-05, RX 50 2T 03-04, TUONO 50 2T 03-04

BETA RR 2T 50 EU4 50 2T 18-20, RR 50 RACING EU4 50 2T 18-20, RR ALU 50 2T 08-12, RR ENDURO 50 2T 06-17, RR MOTARD 50 2T 06-17

CH HUSQUARNA SM 50 2T 00-10, WR 50 2T 00-10, WSM 50 2T 00-10

CMC ENDURO 50 2T 11-11, MOTARD 50 2T 11-11

FANTIC CABALLERO MOTARD 50 2T 06-10, CABALLERO MOTARD COMPETITION 50 2T 06-10, CABALLERO REGOLARITÀ COMPETITION 50 2T 06-10, ENDURO COMPETITION EU4 50 2T 18-20, ENDURO PERFORMANCE EU4 50 2T 18-20, MOTARD COMPETITION EU4 50 2T 18-20, MOTARD PERFORMANCE EU4 50 2T 18-20

HM BAJA, DERAPAGE BASIC 50 2T 10-11, CMC 50 2T 10-11, CRE BAJA RR, DERAPAGE RR 50 2T 07-11, CRE BAJA, DERAPAGE 50 2T 07-11, CRE SIX COMPETITION 50 2T 10-11, CRE SIX, BAJA, DERAPAGE 50 2T 95-06, CRE SIX, DERAPAGE COMPETITION 50 2T 07-09, DERAPAGE COMPETITION 50 2T 10-11

MALAGUTI CNK DRAGON 50 2T 05-07, XSM 50 2T 03-06, XSM POWER-UP 50 2T 07-10, XTM 50 2T 03-03, XTM 50 2T 06-06, XTM POWER-UP 50 2T 07-10

MBK X LIMIT 50 2T 03-04, X POWER 50 2T 03-04

MINARELLI MOTORE AM 6 1° SERIE 50 2T 96-11, MOTORE AM 6 2° SERIE 50 2T 12-18

MOTORHISPANIA FURIA 50 2T 97-00, FURIA MAX 50 2T 10-12, RX 50 2T 09-12, RX R 50 2T 09-12

PEUGEOT SUPERMOTARD 50 2T 90-02, XP6 TRAIL S/AVV. ELETTRICO 50 2T 90-02, XR6 RACING CAT. C/AVV.ELETT. 50 2T 90-02

RIEJU MRT 50 2T 09-12, MRT 50 EU4 50 2T 18-20, MRT PRO 50 2T 09-12, MRT PRO EU4 50 2T 18-20, MRT PRO REPLICA EU4 50 2T 18-20, MRT PRO REPLICA SM EU4 50 2T 18-20, MRT PRO SM 50 2T 09-12, MRT PRO SM EU4 50 2T 18-20, MRT TROPHY EU4 50 2T 18-20, MRX 50 2T 01-04, MRX PRO 50 2T 01-04, RR 50 2T 05-06, RS1 50 2T 98-01, RS2 MATRIX 50 2T 05-06, RS2 MATRIX PRO 50 2T 05-06, RS2 NAKED 50 2T 04-05, RS3 EU4 50 2T 18-20, RS3 NKD EU4 50 2T 18-20, SMX E.S./K.S. 50 2T 01-01, SMX PRO E.S./K.S. 50 2T 03-03, SPIKE 50 2T 98-01

SHERCO FACTORY SE-R EU4 50 2T 18-20, FACTORY SE-RS EU4 50 2T 18-20, FACTORY SILVER SM-R EU4 50 2T 18-20, FACTORY SILVER SM-RS EU4 50 2T 18-20, FACTORY SM-R EU4 50 2T 18-20, FACTORY SM-RS EU4 50 2T 18-20, HRD ENDURO 50 2T 09-13, HRD MOTARD 50 2T 09-13

VENT BAJA 50 2T 18-20, BAJA RR 50 2T 18-20, DERAPAGE 50 2T 18-20, DERAPAGE RR 50 2T 18-20

YAMAHA DT R 50 2T 03-11, DT RSM 50 2T 03-05, DT X 50 2T 06-11, TZR 50 2T 03-08, TZR 50 2T 10-11, TZR RR 50 2T 05-05

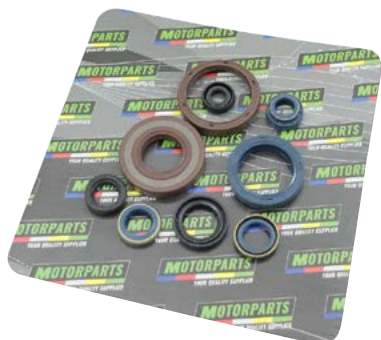

◀ cod. **HUSSR0128**
Serie paraoli motore

NOVITÀ

APPLICABILITÀ

HUSQVARNA CR (HUSQVARNA ENGINE) 125 2T 97-14, SM /S (HUSQVARNA ENGINE) 125 2T 98-14, WR (HUSQVARNA ENGINE) 125 2T 97-14, WRE 125 2T 98-12



◀ cod. **KTMSR0125**
Serie paraoli motore

NOVITÀ

APPLICABILITÀ

HUSABERG TE 125 2T 12-14

HUSQVARNA TC (KTM ENGINE) 125 2T 14-15, TE (KTM ENGINE) 125 2T 14-16

KTM EGS 125 2T 98-05, EXC 125 2T 98-16, EXC SIX DAYS 125 2T 06-14, MXC 125 2T 02-05, SX 125 2T 98-15, SX 144 2T 08-09, SX 150 2T 09-15, XC 150 2T 09-14, EGS 200 2T 98-05, EXC 200 2T 98-16, MXC 200 2T 02-05, SX 200 2T 98-12, XC 200 2T 08-08, XC-W 200 2T 06-15



◀ cod. **YAMSR0152**
Serie paraoli motore

NOVITÀ

APPLICABILITÀ

YAMAHA DT R 125 2T 99-00, DT RE 125 2T 04-06, DT X 125 2T 05-06



- ◀ cod. **K060040**
Serie paraoli Vespa 50-125 Primavera-125 ET3
- ◀ cod. **K06004A**
Serie paraoli originali Vespa 50-125 Primavera 125 ET3
- ◀ cod. **K060050**
Serie paraoli Piaggio Vespa 125PX-150 PX-T5
- ◀ cod. **K060070**
Serie paraoli Vespa 125 PX Arcobaleno
- ◀ cod. **K060100**
Serie paraoli banco Vespa 50 PK-XL Ape 50
- ◀ cod. **K070050**
Serie paraoli scooter 50 cc Minarelli/Yamaha (6 pezzi)
- ◀ cod. **K070060**
Serie paraoli (AM 345/6)
- ◀ cod. **K070070**
Serie paraoli banco scooter 50 cc Minarelli/Yamaha
- ◀ cod. **K070080**
Serie paraoli banco scooter 50 cc Piaggio/Gilera
- ◀ cod. **K070090**
Serie paraoli banco AM 345/6
- ◀ cod. **K070100**
Serie paraoli banco scooter Piaggio Skipper 125/150 cc 2T
- ◀ cod. **K070110**
Serie paraoli banco Piaggio Beverly 125/200 4T
- ◀ cod. **K070120**
Serie paraoli banco Aprilia Scarabeo 125/150
- ◀ cod. **K070130**
Serie paraoli banco Honda Forsight 250 cc



◀ cod. **H102670**
Aprilia: 125/150 cc (motori Rotax)
 misure: 10x26x7

◀ cod. **H202840**
Mbk: Booster 100 cc, Skyliner 125 cc
Yamaha: Majesty 125cc
 misure: 20x28x4

◀ cod. **H203050**
Kymco: People 125/150 cc
 misure: 19,8x30x5 in viton

◀ cod. **H203260**
Kymco: People 125/150 cc
 misure: 20x32x6

◀ cod. **H223270**
Mbk: Skyliner 125cc
Yamaha: Majesty 125cc
 misure: 22x32x7

◀ cod. **H254080**
Kymco: People 125/150 cc
 misure: 25x40x8

◀ cod. **H255270**
Aprilia: 125/150 cc (motori Rotax)
 misure: 25x52x7 in viton

◀ cod. **H274170**
Honda: 125/150 cc
 misure: 27,4x41x7

◀ cod. **H274270**
Kymco: People 125/150 cc
 misure: 27x42x7

◀ cod. **H284080**
Honda: 250 cc
 misure: 27,9x40x8

◀ cod. **H294370**
Honda: 125/150 cc
 misure: 29,4x43x7

◀ cod. **H305270**
Aprilia: 125/150 cc (motori Rotax)
 misure: 30x52x7

◀ cod. **H345260**
Suzuki: Burgman 250/400 cc
 Epicuro 125/150 cc
 misure: 34x52x5,8 in viton

◀ cod. **H372560**
Suzuki: Burgman 400 cc
 misure: 37x25x6

◀ cod. **H385270**
Suzuki: Burgman 250/400 cc
 misure: 38x52x7



◀ cod. **PB00900**
Pompa Benzina Yamaha T-Max 500/530 Suzuki Burgman 125/200 cc

APPLICABILITÀ

SUZUKI UH BURGMAN K7/LO 125 4T 07-10, UH BURGMAN L1 125 4T 11-11, UX SIXTEEN K8/LO 125 4T 08-10, UX SIXTEEN L1 125 4T 11-11, UX SIXTEEN K8/LO 150 4T 08-10, UX SIXTEEN L1 150 4T 11-11, UH BURGMAN K7/LO 200 4T 07-10, UH BURGMAN L1 200 4T 11-12

YAMAHA NEO'S 4 50 4T-3V 09-15, X-MAX R 125 4T-4V 06-14, X-MAX R ABS 125 4T-4V 11-11, X-MAX RA ABS 125 4T-4V 14-15, X-MAX 250 4T 07-16, X-MAX ABS 250 4T 11-12, X-MAX ABS 250 4T 14-15, X-MAX BLACK 250 4T 09-09, X-MAX SPORT 250 4T 11-12, MAJESTY 400 4T 04-11, MAJESTY ABS 400 4T 07-11, T-MAX 4BS 500 4T 09-11, T-MAX 4BS ABS 500 4T 08-11, T-MAX SVU 500 4T 04-08, T-MAX SVU ABS 500 4T 05-07, T-MAX SVU BLACK MAX 500 4T 06-06, T-MAX SVU BLACK MAX - NIGHT MAX 500 4T 07-07, T-MAX SV 500 4T 11-11, T-MAX SV ABS 500 4T 10-11, T-MAX WHITE MAX 500 4T 10-10, T-MAX 59C 530 4T 12-16, T-MAX 59C ABS 530 4T 12-16, T-MAX 59C SP ABS 530 4T 15-15, T-MAX 59C SP ABS 530 4T 15-16



◀ cod. **PB00901**
Pompa Benzina Honda SH 125/150/300 cc

APPLICABILITÀ

HONDA SH IE SCOOPY 125 4T-2V 05-12, SH IE SCOOPY 150 4T 05-12, SH IE SCOOPY 300 4T-4V 07-19



◀ cod. **PB00902**
Kit Pompa Benzina Scooter Piaggio 125/250/300 cc

APPLICABILITÀ

APRILIA SCARABEO LIGHT 250 4T 06-08, SPORT CITY CUBE 250 4T 08-12, SPORT CITY STREET 300 4T-4V 12-12

PIAGGIO VESPA GTS 4T IE SUPER 125 4T 09-16, BEVERLY IE EU3 250 4T 06-08, BEVERLY SPORT 250 4T 06-08, VESPA GTS IE TOURING 300 4T 11-12, VESPA GTS SUPER 300 4T 08-16, VESPA GTS SUPER SPORT 300 4T 10-13, VESPA GTV 4T 4V IE 300 4T 10-13, VESPA GTV VIA MONTENAPOLEONE 300 4T 10-10



◀ cod. **PB00903**
Kit Pompa Benzina Piaggio 500 cc

APPLICABILITÀ

APRILIA SCARABEO LIGHT 400 4T 06-08, SCARABEO LIGHT 500 4T 06-08

PIAGGIO BEVERLY 500 4T 02-06

MALAGUTI SPIDER MAX GT 500 4T 04-05, SPIDER MAX GT EU3 500 4T 06-06, SPIDER MAX RS 500 4T 08-08



◀ cod. **PB00904**
Pompa Benzina Suzuki Burgman 400 cc K7

APPLICABILITÀ

KAWASAKI NINJA ZX-6R 600 4T 07-16, NINJA ZX-6R 636 4T 13-16,
NINJA ZX-6R ABS 636 4T 13-16

SUZUKI AN BURGMAN K7/LO 400 4T 07-10, AN BURGMAN L1 400
4T 11-11, AN BURGMAN L2 400 4T 12-12, AN BURGMAN
L3 400 4T 13-13, AN BURGMAN L4 400 4T 14-14, AN
BURGMAN L5 400 4T 15-15, AN BURGMAN L6 400 4T
16-16



◀ cod. **PB00905**
Kit Pompa Benzina BMW R1200GS

APPLICABILITÀ

BMW R 1200 GS (K25) 1200 4T 02-09, R 1200 GS ADVENTURE
(K25) 1200 4T 05-13, R RT (K26) 1200 4T 03-14, K GT
(K44) 1300 4T 04-10



◀ cod. **PB00907**
Pompa Benzina Honda SH 125/150 cc ABS '13-'17

APPLICABILITÀ

HONDA SH I ABS 125 4T-2V 13-17, SH I ABS 150 4T-2V 13-17



◀ cod. **PB00908**
Pompa benzina Yamaha T-Max 530 cc dal'17

APPLICABILITÀ

YAMAHA XP530-A T-MAX SX 530 4T 17-19, XP530D-A T-MAX DX 530
4T 17-19, XP530E-A T-MAX 530 4T 17-18



◀ cod. **AA00850**
Tasselli traino Piaggio 125/150/180/200 cc

RIFERIMENTO ORIGINALE

PIAGGIO	4348555
---------	---------

◀ cod. **AA00852**
Tasselli traino Majesty 250 cc

◀ cod. **AA00853**
Serie Tasselli di Traino Suzuki Burgman 125/250/400 cc - Honda 300/400 cc

RIFERIMENTO ORIGINALE

Suzuki	21481-14F00-000
Honda	22011-KAB-000

Honda	22011-MCT-305
-------	---------------

◀ cod. **AA00854**
Serie tasselli di traino Honda SH 125/150 cc fino al 2012

RIFERIMENTO ORIGINALE

Honda	22011-KCW-851
-------	---------------

APPLICABILITÀ

HONDA @ [NES] 125 4T 00-06, DYLAN [SES] 125 4T 02-04, PANTHEON IE [FES] 125 4T-2V 03-05, PS I [PES] 125 4T 06-10, SH 125 4T-2V 01-04, SH IE SCOOPY 125 4T-2V 05-12, SILVER WING [FES] 125 4T-2V 07-12, @ [NES] 150 4T 00-06, DYLAN [SES] 150 4T 02-04, PANTHEON IE [FES] 150 4T-2V 03-05, PS I [PES] 150 4T 06-10, SH 150 4T-2V 01-04, SH IE SCOOPY 150 4T 05-12, SILVER WING [FES] 150 4T-2V 07-12

NOVITÀ

◀ cod. **AA00855**
Serie tasselli di traino Honda SH 125/150 cc dal 2013

RIFERIMENTO ORIGINALE

Honda	22011-KWN-900
-------	---------------

APPLICABILITÀ

HONDA SH I ABS 125 4T-2V 13-19, SH I ABS 150 4T-2V 13-19

◀ cod. **ML06232**
Molla contrasto variatore grezza carico tipo originale per motori scooter 50 cc Minarelli/Yamaha con campana frizione Ø interno 105 mm

◀ cod. **PL04055**
Puleggia fissa anteriore per motori scooter 50 cc Minarelli/Yamaha



◀ cod. **PL04056**

Puleggia fissa anteriore per motori per scooter 50 cc Minarelli/Yamaha completa di piastrina



◀ cod. **PL04058**

Puleggia fissa anteriore per motori scooter 50 cc Gilera/Piaggio

RIFERIMENTO ORIGINALE

Piaggio	479561
---------	--------



◀ cod. **PL04059**

Puleggia mobile anteriore per motori scooter 50 cc Piaggio/Gilera con masse Ø 19



◀ cod. **PL04060**

Puleggia fissa anteriore per motori scooter Gilera/Piaggio 125/150 cc Ø esterno 142 mm

RIFERIMENTO ORIGINALE

Piaggio	485118
---------	--------



◀ cod. **PL04061**

Puleggia fissa anteriore per motori scooter 180 cc 4T Piaggio

RIFERIMENTO ORIGINALE

Piaggio	832720
---------	--------



◀ cod. **PL04062**
Puleggia mobile per motori scooter 125/150/180 cc 4T Piaggio

RIFERIMENTO ORIGINALE

Piaggio	CM103901
---------	----------



◀ cod. **PL04063**
Puleggia fissa per motori scooter 50 cc Aprilia D.Tech

RIFERIMENTO ORIGINALE

APRILIA	AP3MEA000620
---------	--------------



◀ cod. **PL04064**
Puleggia mobile completa per motori scooter 50 cc Aprilia D.Tech



◀ cod. **PL04066**
Piattello porta tasselli Majesty 250 cc

RIFERIMENTO ORIGINALE

YAMAHA	1C0E76231000
--------	--------------

YAMAHA	4HC176230000
--------	--------------

RICAMBIO

AA00852	Tasselli traino
---------	-----------------



◀ cod. **PL04067**
Piattello porta tasselli Piaggio 125/150/180/200 cc

RIFERIMENTO ORIGINALE

Piaggio	842204
---------	--------

RICAMBIO

AA00850	Tasselli traino
---------	-----------------

AA00851	Distanziale
---------	-------------



◀ cod. **PL04072**
Puleggia fissa anteriore completa scooter Piaggio 125/150 cc

RIFERIMENTO ORIGINALE

Piaggio	8456075
---------	---------



◀ cod. **PL04073**
Puleggia fissa anteriore Honda SH 125/150 cc fino al 2012

RIFERIMENTO ORIGINALE

Honda	22102-KGF-910
-------	---------------



◀ cod. **PL04074**
Puleggia fissa anteriore Kymco Agility 125/150/200 cc

RIFERIMENTO ORIGINALE

KYMCO	00126115	KYMCO	22102KUDU220
-------	----------	-------	--------------



◀ cod. **PL04075**
Puleggia fissa anteriore Minarelli/Yamaha YP 250/270 cc



◀ cod. **PL04076**
Puleggia fissa anteriore Honda SH 300cc - Forza 300cc

RIFERIMENTO ORIGINALE

Honda	22102-KTW-900
Honda	22102KTW900

NOVITÀ



◀ cod. **PL04077**
Puleggia fissa anteriore Honda SH ABS 125/150cc 13-19

RIFERIMENTO ORIGINALE

Honda	22102-K01-900
-------	---------------

NOVITÀ

NOVITÀ



◀ Cod. **PI04078**

Piatello porta tasselli variatore Honda SH-Forza 300cc

RIFERIMENTO ORIGINALE

Honda	22131-KTW-900
-------	---------------

NOVITÀ



◀ cod. **PL04079**

Puleggia fissa anteriore Yamaha X-Max 300cc

RIFERIMENTO ORIGINALE

Yamaha	B74E76110000
--------	--------------

NOVITÀ



◀ cod. **PL04091**

Piatello porta tasselli variatore Yamaha X-Max 300cc

RIFERIMENTO ORIGINALE

Yamaha	B74E76230000
--------	--------------



◀ **cod. RD00001**
Regolatore **Ducati** per Enduro 50 cc Malaguti/Yamaha

RIFERIMENTO ORIGINALE

Malaguti	02602100	Yamaha	1D4H35980000
----------	----------	--------	--------------

APPLICABILITÀ

MALAGUTI	CNK DRAGON 50 2T 05-07, XSM 50 2T 03-03, XTM 50 2T 03-03	YAMAHA	DT R 50 2T 03-06, DT RSM 50 2T 03-05, DT X 50 2T 06-06
-----------------	--	---------------	--



◀ **cod. RE00004**
Regolatore per scooter 500 cc Piaggio

RIFERIMENTO ORIGINALE

Piaggio	639110	Gilera	639110
Aprilia	639110	Derbi	639110

APPLICABILITÀ

APRILIA	SR MAX 125 4T 11-14, ATLANTIC EU3 250 4T 06-08, SCARABEO LIGHT 250 4T 06-08, SPORT CITY CUBE 250 4T 08-12, SPORT CITY EU3 250 4T 06-08, SCARABEO LIGHT 300 4T 09-10, SPORT CITY STREET 300 4T-4V 12-12, SR MAX 300 4T 11-14, ATLANTIC SPRINT 400 4T 05-08, SCARABEO LIGHT 400 4T 06-08, ATLANTIC 500 4T 01-04, ATLANTIC SPRINT 500 4T 05-08, SCARABEO 500 4T 03-06, SCARABEO LIGHT 500 4T 06-08	PIAGGIO	MP3 IBRIDO 125 4T 09-10, MP3 IE 125 4T 08-09, BEVERLY CRUISER 250 4T 07-09, BEVERLY IE EU3 250 4T 06-08, BEVERLY SPORT 250 4T 06-08, BEVERLY TOURER EU3 250 4T 07-09, CARNABY 250 4T 08-09, MP3 250 4T 06-08, MP3 LT 250 4T 08-09, MP3 MIC 250 4T 08-09, VESPA GT 60 EU3 250 4T 06-07, VESPA GTS 250 4T 05-16, VESPA GTS ABS 250 4T 05-12, VESPA GTV 250 4T 06-09, VESPA GTV 4T NAVY EU3 250 4T 07-07, X-EVO 250 4T 07-16, X7 EU3 250 4T 08-08, X8 EU3 250 4T 05-08, BEVERLY TOURER EU3 300 4T 09-10, CARNABY CRUISER 300 4T 09-12, VESPA GTS SUPER 300 4T 08-16, BEVERLY EU3 400 4T 06-07, BEVERLY TOURER EU3 400 4T 08-10, MP3 400 4T 07-08, MP3 IE LT TOURING 400 4T 11-11, MP3 IE LT/SPORT 400 4T 08-10, MP3 MIC 400 4T 08-10, MP3 RL TOURING 400 4T 11-11, X-EVO 400 4T 07-11, X8 EU3 400 4T 06-08, BEVERLY 500 4T 02-06, BEVERLY CRUISER 500 4T 07-12, BEVERLY IE EU3 500 4T 06-08, MP3 LT SPORT/BUSINESS 500 4T 11-13, MP3 RL SPORT-BUSINESS 500 4T 11-12, X9 500 4T 01-02, X9 EVOLUTION 500 4T 03-07, X9 EVOLUTION ABS 500 4T 06-07
DERBI	GP1 LOW SEAT EU3 250 4T 07-08, RAMBLA 250 4T 08-09, RAMBLA EU3 2VER 250 4T 08-08, RAMBLA 300 4T 10-11		
GILERA	NEXUS IE EU3 125 4T 08-10, NEXUS EU3 250 4T 06-07, NEXUS SP EU3 250 4T 06-07, NEXUS EU3 300 4T 08-11, FUOCO IE EU3 500 4T 07-13, NEXUS 500 4T 03-05, NEXUS EU3 500 4T 06-11, NEXUS SP EU3 500 4T 06-07		



◀ **cod. RE00008**
Regolatore di tensione per Vespa PX 50-125 cc

RIFERIMENTO ORIGINALE

Piaggio	2308245
---------	---------

APPLICABILITÀ

PIAGGIO	APE TM P 50 2T 85-89, VESPA FL 50 2T 90-90, VESPA N 50 2T 89-90, VESPA PK XL 50 2T 85-88, VESPA PK XL RUSH 50 2T 88-89, COSA 2 125 2T 91-97, COSA CL, CLX 125 2T 88-91, VESPA FL 125 2T 89-90, VESPA PK XL 125 2T 86-89, VESPA PX 125 2T 98-01, VESPA PX 125 2T 11-16, VESPA PX 30 ANNI 125 2T 07-08, VESPA PX EU2 125 2T 01-07, COSA 2 150 2T 91-97, COSA CL, CLX 150 2T 88-91, VESPA PX 150 2T 98-01, VESPA PX 150 2T 11-16, COSA 2 200 2T 91-97, COSA CL, CLX 200 2T 88-91, VESPA PX 200 2T 98-01
----------------	--



◀ **cod. RE00009**
Regolatore di tensione per Vespa PK 50-125 cc

RIFERIMENTO ORIGINALE

Piaggio	2940165
---------	---------

APPLICABILITÀ

GILERA	EASY MOVING 50 2T 95-96, STORM 50 2T 94-95, TYPHOON 50 2T 94-97
PIAGGIO	APE FL - FL2 50 2T 89-95, APE FL3 EUROPA 50 2T 96-99, FREE 50 2T 92-94, FREE FL 50 2T 95-02, NRG 50 2T 94-96, NRG RST MC2 50 2T 96-98, NTT 50 2T 95-96, QUARTZ 50 2T 92-96, SFERA 50 2T 91-93, SFERA MAQUILLAGE 2 50 2T 94-94, SFERA RST 50 2T 95-97, VESPA ET2 50 2T 97-05, VESPA FL2 AUTOMATICA 50 2T 90-91, VESPA FL2 HP 50 2T 91-97, ZIP 50 2T 92-93, ZIP 50 2T 95-96, ZIP FAST RIDER 50 2T 93-94, ZIP FAST RIDER RST 50 2T 96-97, ZIP RST 50 2T 96-99, ZIP SP 50 2T 96-00, SFERA 125 4T 95-97



cod. RE00010

Regolatore di tensione per Vespa ET4 125 - PX Arcobaleno 125/150/200 cc

RIFERIMENTO ORIGINALE

Piaggio	1616395
---------	---------

APPLICABILITÀ

PIAGGIO VESPA PK XL PLURIMATIC 50 2T 85-90, VESPA PX E ARCOBALENO 125 2T 81-97, VESPA PXT5 125 2T 85-89, VESPA PX E ARCOBALENO 150 2T 81-97, VESPA PX E ARCOBALENO 200 2T 81-97



cod. RE00011

Regolatore di tensione per Majesty 125cc

RIFERIMENTO ORIGINALE

Piaggio	58090R
Yamaha	5NRW19600000

APPLICABILITÀ

APRILIA SR R FACTORY IE 50 2T 10-14, SR R FACTORY IE 50 2T-IE 10-12, ATLANTIC 125 4T 03-05, ATLANTIC EU3 125 4T 06-08, ATLANTIC EU3 125 4T 10-12, MOJITO 125 4T 03-08, RS4 125 4T 11-13, SCARABEO 125 4T 03-06, SCARABEO EU3 125 4T 06-07, SPORT CITY 125 4T 04-06, SPORT CITY CUBE 125 4T 08-10, SPORT CITY EU3 125 4T 06-08, SPORT CITY ONE 4T EU3 125 4T 08-11, SPORT CITY STREET 125 4T 12-12, MOJITO 150 4T 03-07, SCARABEO 150 4T 04-06

DERBI BOULEVARD 125 4T 02-04, BOULEVARD 4T EU3 125 4T 08-12, BOULEVARD EU2 125 4T 04-07, GP1 EU 2 125 4T 06-06, GP1 LOW SEAT EU3 125 4T 07-08, RAMBLA 125 4T 08-09, RAMBLA EU3 2VER 125 4T 08-08, SONAR 4T 125 4T 09-11, VARIANT SPORT 4T EU3 125 4T 12-12, BOULEVARD 150 4T 02-04, BOULEVARD 4T E3 150 4T 10-10, BOULEVARD EU3 150 4T 04-07, SONAR 4T 150 4T 09-09, BOULEVARD EU2 200 4T 05-06, GP1 250 4T 06-07

GILERA RUNNER PURE JET 50 2T-IE 02-07, RUNNER PURE JET 50 2T-IE 10-11, RUNNER PURE JET ST 50 2T-IE 08-08, DNA 125 4T 01-01, NEXUS EU3 125 4T 07-08, RUNNER 4T ST EU3 125 4T 08-16, RUNNER VX 125 4T 00-06, RUNNER VX 4T EU3 125 4T 06-07, RUNNER VX RACE 125 4T 06-06, RUNNER VX SC 125 4T 06-07, RUNNER VXR RACE 200 125 4T 06-06, DNA 180 4T 01-01, RUNNER VXR 200 4T 02-06, RUNNER VXR 4T ST EU3 200 4T 08-11, RUNNER VXR EU3 200 4T 07-07, OREGON 250 4T 06-10

PIAGGIO APE 50 2T 12-17, APE EU4 50 2T 18-18, NRG POWER PUREJET 50 2T-IE 04-11, NRG PUREJET 50 2T-IE 02-04, NRG PUREJET 50 2T-IE 10-10, BEVERLY 125 4T 01-03, BEVERLY EU3 125 4T 07-08, BEVERLY EURO 3 MIC 125 4T 07-07, BEVERLY EURO 3 SPORT 125 4T 07-08, BEVERLY RST 125 4T 04-07, BEVERLY TOURER EU3 125 4T 07-10, CARNABY 125 4T 07-10, FLY 125 4T 05-07, FLY EU3 125 4T 07-11, HEXAGON GTX 125 4T 00-00, LIBERTY 125 4T 01-02, LIBERTY 4T 125 4T 06-07, LIBERTY 4T EU3 125 4T 06-08, LIBERTY 4T EU3 DELIVERY - TNT 125 4T 08-15, LIBERTY 4T SPORT EU3 125 4T 06-08, LIBERTY RST 125 4T 04-05, LIBERTY SPORT 125 4T 06-06, MP3 125 4T 06-08, SKYPPER 4T 125 4T 00-02, SUPER HEXAGON GTX 12 125 4T 01-02, TYPHOON 4T 2V E3 125 4T 10-11, VESPA ET4 125 4T 99-02, VESPA GRANTURISMO 125 4T 03-07, VESPA GRANTURISMO EU3 125 4T 06-07, VESPA GTS EU3 125 4T 07-12, VESPA GTV 125 4T 06-08, VESPA GTV 4T NAVY EU3 125 4T 08-08, VESPA LX 125 4T 05-06, VESPA LX 4T FL 125 4T 09-09, VESPA LX EU3 125 4T 06-08, VESPA LXV 4T EU3 125 4T 06-09,

VESPA LXV NAVY EU3 125 4T 07-08, VESPA S 4T EU3 125 4T 07-08, X-EVO 125 4T 07-16, X7 EU3 125 4T 08-08, X8 125 4T 04-06, X8 PREMIUM EU2 125 4T 06-06, X8 PREMIUM EU3 125 4T 06-07, X8 STREET EU2 125 4T 06-07, X9 125 4T 01-02, X9 EVOLUTION 125 4T 03-03, X9 EVOLUTION 125 4T 05-06, X9 EVOLUTION EU3 125 4T 07-07, ZIP 125 4T 00-02, FLY 150 4T 05-07, FLY EU3 150 4T 08-11, LIBERTY 4T EU3 150 4T 08-08, LIBERTY 4T SPORT EU3 150 4T 08-08, LIBERTY MOC 4T 150 4T 09-13, VESPA LX 150 4T 05-06, VESPA LX 4T FL 150 4T 09-09, VESPA LX EU3 150 4T 06-08, VESPA S 4T 150 4T 08-09, X8 STREET EU2 150 4T 06-08, SUPER HEXAGON GTX 12 180 4T 01-02, X9 AMALFI 180 4T 00-03, CARNABY 200 4T 07-08, LIBERTY 200 4T 06-06, LIBERTY 4T EU3 200 4T 06-08, LIBERTY 4T SPORT EU3 200 4T 06-07, LIBERTY RST 200 4T 04-04, LIBERTY SPORT 200 4T 06-06, VESPA GRANTURISMO 200 4T 03-07, X8 200 4T 05-07, X9 200 4T 02-03, X9 EVOLUTION 200 4T 03-03, BEVERLY 250 4T 05-07, BEVERLY RST 250 4T 04-05, X9 EVOLUTION 250 4T 04-04, X9 EVOLUTION 250 4T 06-06

cod. RE00012

Regolatore di tensione per Aprilia Scarabeo 50 2T - Ape '03/'10

RIFERIMENTO ORIGINALE

Piaggio	58096R
---------	--------

APPLICABILITÀ

APRILIA SCARABEO 2T EU2 MOTORE PIAGGIO 50 2T 10-12, SCARABEO 2T NET 50 2T 09-10, SCARABEO STREET 50 2T 05-06, SCARABEO STREET 2T RESTYLING 50 2T 06-09, SPORT CITY ONE 2T 50 2T 08-11, SR MOTARD 50 2T 12-14, SR R 50 2T 04-09, SR R FACTORY CARBURATORE 50 2T 10-14, SR STEALTH 50 2T 97-00, SR STREET CARBURATORE 50 2T 03-12, MOJITO RETRO 'CUSTOM 125 4T 99-01, SR MOTARD 125 4T-2V 12-14

DERBI ATLANTIS 02 50 2T 02-02, BOULEVARD 2T 50 2T 09-14, GP1 50 2T 01-03, GP1 EU 2 50 2T 05-05, GP1 OPEN EU2 50 2T 06-09, GP1 RACE EU2 50 2T 05-07, SONAR 2T 50 2T 09-09

GILERA DNA 50 2T 00-02, DNA 50 2T 05-07, DNA GP EXPERIENCE 50 2T 03-04, ICE 50 2T 01-05, RUNNER 50 2T 97-00, RUNNER POGGIALI 50 2T 02-02, RUNNER SP 50 2T 02-07, RUNNER SP 50 2T 10-12, RUNNER SP SPECIAL EDITION 50 2T 07-07, RUNNER SP ST & SIMONCELLI 50 2T 08-09, STALKER 50 2T 97-11, STALKER NAKED 50 2T 08-08, STALKER SPECIAL EDITION 50 2T 07-08, STORM EURO 2 50 2T 07-07, TYPHOON X 50 2T 98-99, TYPHOON XR 50 2T 00-00

PIAGGIO APE 50 2T 09-11, APE MIX 2T 50 2T 98-08, APE RST MIX 50 2T 99-03, DIESIS 50 2T 01-01, FLY 2T 50 2T 05-07, FLY 2T 50 2T 10-11, FREE DELIVERY 50 2T 00-01, LIBERTY 50 2T 97-05, LIBERTY 2T 50 2T 06-08, LIBERTY 2T PTT EU2 50 2T 04-05, LIBERTY 2T RST 50 2T 04-04, LIBERTY 2T SPORT 50 2T 06-08, LIBERTY MOC 2T & ELLE 50 2T 09-13, NRG EXTREME LC 50 2T 99-00, NRG MC3 50 2T 01-04, NRG POWER DD 50 2T 05-17, NRG POWER DD SERIE SPECIALE 50 2T 07-12, NRG POWER DT 50 2T 06-15, NRG POWER DT SERIE SPECIALE 50 2T 07-08, TYPHOON 50 2T 01-11, TYPHOON 2T E2 50 2T 10-12, TYPHOON 2T E3 CH 50 2T 11-11, VESPA LX 2T 50 2T 05-13, VESPA LXV 2T 50 2T 06-09, VESPA LXV 2T NAVY 50 2T 08-08, VESPA S 2T & COLLEGE 50 2T 07-12, ZIP 2T 50 2T 08-13, ZIP LC 50 2T 00-04, ZIP SP 50 2T 01-04, ZIP SP EURO 2 50 2T 06-13, HEXAGON LX4 125 4T 98-99, LIBERTY 125 4T 98-00, VESPA ET4 125 4T 96-98





◀ **cod. RE00013**
Regolatore di tensione per Kymco - Sym

RIFERIMENTO ORIGINALE

Kymco	00169004
Malaguti	02601500

Sym	31600KBN920
-----	-------------

APPLICABILITÀ

KYMCO AGILITY 4T R10 50 4T 06-08, AGILITY 4T R12 50 4T 07-08, AGILITY R12 50 4T 05-05, B&W 50 2T 02-02, B&W EU2 50 2T 03-03, CX 50 2T 93-93, CX SUPER 50 2T 94-97, DINK LC 50 2T 98-02, DINK 50 4T 50 4T 07-07, DINK CLASSIC EU2 50 2T 03-03, DJ WORLD 50 2T 94-00, DJ X 50 2T 91-92, DJ Y 50 2T 93-93, FEVER ZX 50 2T 99-00, FEVER ZX EU2 50 2T 03-04, FILLY 50 4T 98-00, FILLY LX 50 4T 01-02, HEROISM 50 2T 95-97, K 12 50 2T 95-00, KB 50 2T 95-00, MXER 50 2T 02-03, MXER EU2 50 2T 04-04, PEOPLE 50 2T 99-04, PEOPLE EURO 2 50 2T 03-03, PEOPLE EURO 2 50 2T 08-08, PEOPLE S 4T 50 4T 06-08, SNIPER 50 2T 93-93, SNIPER DD 50 2T 94-96, SUPER 9 50 2T 00-00, SUPER 9 EU2 50 2T 03-04, TOP BOY 50 2T 97-00, VITALITY 2T 50 2T 04-04, VITALITY 4T 50 4T 04-04, YUP 50 2T 02-02, YUP EU2 50 2T 03-03, AGILITY 125 4T 06-06, AGILITY EU3 125 4T 06-08, MOVIE 125 4T 99-00, MOVIE EU3 125 4T 06-07, MOVIE XL 125 4T 01-01, MOVIE XL EU2 125 4T 03-04, PEOPLE 125 4T 99-00, PEOPLE EU2 125 4T 03-03, PEOPLE EU3 125 4T 07-08, VIVIO 125 4T 00-00, MOVIE EU3 150 4T 06-07, MOVIE XL 150 4T 01-01, MOVIE XL EU2 150 4T 03-04, PEOPLE 150 4T 99-00, PEOPLE EU2 150 4T 03-03, VIVIO 150 4T 00-00

MALAGUTI CIAK 125 4T 00-01, CIAK MASTER 125 4T 04-04, CIAK RESTYKING EU2 125 4T 03-03, CIAK 150 4T 00-02, CIAK MASTER 150 4T 04-04, CIAK RESTYKING EU2 150 4T 03-03
SYM JET 50 2T 99-01, JUNGLER 50 2T 99-00, MASK 50 2T 00-01, RED DEVIL 50 2T 99-99, SUPER FANCY 50 2T 98-00, JET 100 2T 99-00, SUPER DUKE 125 4T 99-02, SUPER DUKE 150 4T 99-02

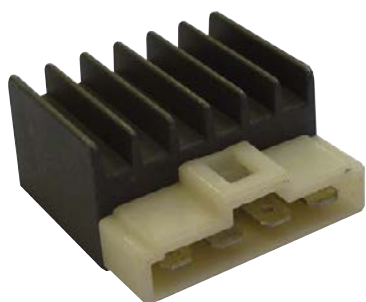

◀ **cod. RE00014**
Regolatore di tensione per F10-F12 - Booster - Nitro

RIFERIMENTO ORIGINALE

Aprilia	AP8212799
Malaguti	02601100

Yamaha	4VWH19600100
--------	--------------

APPLICABILITÀ

APRILIA AMICO 50 2T 94-94, AMICO 50 2T 96-98, AMICO GL/GLE 50 2T 93-95, AMICO LX/SPORT/CAT 50 2T 92-93, GULLIVER 50 2T 95-98, GULLIVER LC 50 2T 96-98, RALLY 50 2T 95-03, RALLY LIQUID COOLED 50 2T 96-99, SCARABEO 50 2T 93-05, SCARABEO 2T NET 50 2T 10-10, SONIC 50 2T 98-07, SONIC GP 50 2T 98-08, SR (ORIZZONTALE) 50 2T 94-96, SR (VERTICALE) 50 2T 93-93, SR LIQUID COOLED 50 2T 94-96, SR RACING 50 2T 97-99, SR STEALTH 50 2T 97-00, SR WWW 50 2T 97-01, SCARABEO (MINARELLI) 100 2T 00-00, SCARABEO (YAMAHA) 100 2T 00-00
MALAGUTI CENTRO SL 50 2T 94-98, CIAK 50 2T 99-01, CIAK EURO2 50 2T 01-03, CROSSER CR1 50 2T 95-98, F10 50 2T 92-00, F10 AC WAP 50 2T 08-08, F10 EURO 2 50 2T 02-06, F12 PHANTOM EURO 2 50 2T 02-02, F12 PHANTOM LC 50 2T 94-98, F12 R PHANTOM AC 50 2T 07-08, F12 RESTYLING EURO 1 50 2T 99-02, F15 FIRE FOX 50 2T 96-98, F15 FIRE FOX AIR COOLED 50 2T 05-06, F15 FIRE FOX EURO 2 50 2T 02-06, YESTERDAY 50 2T 97-00, CIAK 100 4T 99-00, F12 PHANTOM 100 4T 99-00

MBK BOOSTER 50 2T 90-04, BOOSTER 50 2T 90-94, BOOSTER NG 50 2T 95-03, BOOSTER ROCKET 50 2T 97-98, BOOSTER SPIRIT 50 2T 96-00, BOOSTER TRACK 50 2T 96-98, EVOLIS 50 2T 92-95, FIZZ 50 2T 94-95, FLIPPER 50 2T 98-04, FORTE 50 2T 94-96, NITRO 50 2T 97-04, OVETTO 50 2T 97-04, STUNT 50 2T 00-02, NITRO 100 2T 00-02
YAMAHA AEROX 50 2T 97-02, AEROX 50 2T 04-16, AEROX NAKED 50 2T 13-16, AEROX R 50 2T 99-00, AXIS 50 2T 95-96, BREEZE 50 2T 94-95, BW'S 50 2T 97-04, BW'S BUMP 50 2T 97-98, BW'S NAKED 50 2T 03-03, BW'S NEXT GENERATION 50 2T 97-02, BW'S ORIGINAL 50 2T 99-01, NEO'S 50 2T 97-02, NEO'S 50 2T 04-16, NEO'S EASY 50 2T 13-13, RS SPY 50 2T 95-98, SLIDER 50 2T 00-02, WHY 50 2T 98-05, AEROX 100 2T 00-02



◀ **cod. RE00015**
Regolatore di tensione per Yamaha - BW'S - Aerox - Neo's - Nitro

RIFERIMENTO ORIGINALE

Yamaha	5RNH19600000
--------	--------------

APPLICABILITÀ

MBK BOOSTER EURO 2 50 2T 04-04, BOOSTER NG 50 2T 03-03, BOOSTER SPIRIT 50 2T 03-03, BOOSTER SPIRIT EURO2 50 2T 03-03, FLIPPER EURO 2 50 2T 03-03, MACH G 50 2T 02-04, MACH G LC 50 2T 02-04, NITRO EURO 2 50 2T 03-03, OVETTO EURO 2 50 2T 02-02, OVETTO 100 2T 99-02

YAMAHA AEROX EURO 2 50 2T 03-03, BW'S 50 2T 04-16, BW'S EASY 50 2T 13-13, BW'S NAKED 50 2T 04-04, BW'S NAKED 50 2T 09-16, BW'S NEXT GENERATION 50 2T 03-06, BW'S ORIGINAL EURO 2 50 2T 03-03, DT R 50 2T 07-11, DT X 50 2T 07-11, JOG R 50 2T 02-02, JOG R EURO2 50 2T 02-02, JOG R EURO2 50 2T 06-15, JOG R LC 50 2T 02-15, NEO'S EURO 2 50 2T 02-02, TZR 50 2T 03-08, TZR 50 2T 10-11, TZR RR 50 2T 05-05, WHY EURO 2 50 2T 03-05, NEO'S 100 2T 99-02, XT-R 125 4T-2V 05-08, XT-X 125 4T-2V 05-08



◀ cod. **RE00018**
Regolatore di tensione per Scarabeo 50-100 cc 4T - Vespa LX 4T

RIFERIMENTO ORIGINALE

Piaggio	9693825	Malaguti	02602800
---------	---------	----------	----------

APPLICABILITÀ

APRILIA	SCARABEO 4T 50 4T 02-06, SCARABEO 4T RESTYLING EU3 50 4T 06-09, SCARABEO 4T 100 4T 01-05, SCARABEO 4T 100 4T 10-12, SCARABEO 4T NET 100 4T 09-09, SCARABEO 4T NET EU3 100 4T 10-10, SCARABEO 4T RESTYLING 100 4T 06-09	PIAGGIO	FLY 4T 50 4T 05-07, FLY 4T MOTORE CHN 50 4T 06-07, LIBERTY 4T 50 4T 00-02, LIBERTY 4T 50 4T 05-08, LIBERTY 4T DELIVERY - SINGLE 50 4T 10-14, LIBERTY 4T DELIVERY TNT 50 4T 09-09, LIBERTY 4T PTT - DOUBLE - NEXIVE 50 4T 09-17, LIBERTY 4T RST 50 4T 04-04, LIBERTY 4T SPORT 50 4T 06-08, LIBERTY MOC 4T & ELLE 50 4T 09-16, VESPA ET4 50 4T 00-05, VESPA LX 4T 50 4T 05-09, ZIP 4T 50 4T 00-13, FLY 100 4T 06-14, FREE 100 4T 02-03, ZIP 4T 100 4T 06-10
DERBI	ATLANTIS 4T 50 4T 04-06, BOULEVARD 4T EU2 25KM/H 50 4T 09-09, BOULEVARD 4T 100 4T 10-11		
MALAGUTI	CENTRO EURO 2 50 4T 08-08, CENTRO SL 4T 50 4T 10-10, CIAK MASTER EURO 2 50 4T 05-06		



◀ cod. **RE00019**
Regolatore di tensione per People S 250 cc '08/'10 - Agility 125/150 cc R16 '09/'10

RIFERIMENTO ORIGINALE

Kymco	00169587	Malaguti	02603000
-------	----------	----------	----------

APPLICABILITÀ

KYMCO	AGILITY PLUS 4T 50 4T 14-14, AGILITY R12 ECS 50 4T 16-16, AGILITY R16 50 4T 08-09, AGILITY R16 50 4T 12-12, AGILITY R16 2T 50 2T 10-10, AGILITY R16 2T 50 2T 12-12, AGILITY RS 50 4T 09-09, AGILITY RS NAKED 50 2T 10-10, LIKE 50 4T 09-09, SUPER 8 50 2T 09-09, SUPER 8 4T 50 4T 07-07, SUPER 8 4T 50 4T 09-09, AGILITY PLUS 125 4T 14-14, AGILITY R16 125 4T 08-09, AGILITY R16 125 4T 12-12, AGILITY RS 125 4T 09-09, LIKE 125 4T 09-09, PEOPLE S 125 4T 05-05, PEOPLE S DD EU3 125 4T 07-08, SUPER 8 125 4T 08-09, AGILITY R16 150 4T 08-09, LIKE LX 200 4T 12-12, PEOPLE S 200 4T 05-05	MALAGUTI	CIAK MASTER EU3 125 4T 06-06, CIAK MASTER EURO 2 200 4T 06-06
--------------	--	-----------------	---



◀ cod. **RE00020**
Regolatore di tensione per Majesty 125/150 cc '98/'00 - Skyliner 125/150 - Madison 125/150 cc

RIFERIMENTO ORIGINALE

Yamaha	5NRW19600000
--------	--------------

APPLICABILITÀ

MBK	SKYLINER 125 4T 98-02, DOODO 150 4T 01-02, SKYLINER 150 4T 00-02	YAMAHA	MAJESTY 125 4T 98-00, MAJESTY (5NR1) 125 4T 01-01, MAJESTY 150 4T 00-00, MAJESTY (5NS1) 150 4T 01-01, TEO'S 150 4T 01-02
------------	--	---------------	--

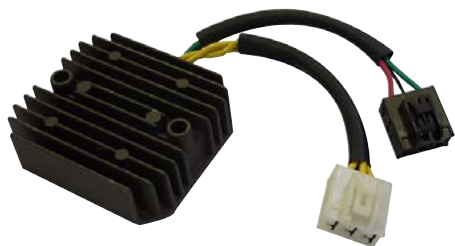

◀ cod. **RE00021**
Regolatore di tensione per Honda SH 125/150 cc IE '05/'10

RIFERIMENTO ORIGINALE

Honda	31600-KTF-641
-------	---------------

APPLICABILITÀ

HONDA SH IE SCOOPIY 125 4T-2V 05-12, SH IE SCOOPIY 150 4T 05-12



◀ cod. **RE00022**
Regolatore di Tensione Yamaha T-MAX 500 '08-'09

RIFERIMENTO ORIGINALE

Yamaha	4XY819600000
--------	--------------

APPLICABILITÀ

YAMAHA XVS DRAG STAR 125 4T 00-03, MAJESTY 250 4T 02-03, MAJESTY ABS 250 4T 03-03, WR250R 250 4T 08-08, WR250R 250 4T 13-13, WR250X 250 4T 08-08, X-MAX 250 4T 05-06, XVS DRAG STAR 250 4T 04-04, VERSITY 300 4T 03-06, MAJESTY 400 4T 04-11, MAJESTY ABS 400 4T 07-11, SR400 400 4T 14-14, T-MAX 4BS 500 4T 09-11, T-MAX 4BS ABS 500 4T 08-11, T-MAX SVU 500 4T 08-08, T-MAX SV 500 4T 11-11, T-MAX SV ABS 500 4T 10-11, T-MAX WHITE MAX 500 4T 10-10, YZF R6 600 4T 07-15, YZF R6 & LIMITED EDITION 07 600 4T 06-06, YZF R6 50TH 600 4T 12-12, MT-03 660 4T 06-11, XT Z TENERE 660 4T 08-13, DRAG STAR CLASSIC XVS A 1100 4T 03-03, DRAG STAR CLASSIC XVS A 1100 4T 06-06, XVS A DRAG STAR CLASSIC 1100 4T 05-05, XVZ TF ROYAL STAR VENTURE 1300 4T 00-00



◀ cod. **RE00023**
Regolatore di Tensione Yamaha X-MAX 250 cc '07-'09

RIFERIMENTO ORIGINALE

Yamaha	5BN819600000
--------	--------------

APPLICABILITÀ

SYM SYMPLY II 125 4T 09-10

YAMAHA X-CITY EU2 125 4T-4V 08-11, X-MAX R 125 4T-4V 06-09, X-MAX R 125 4T-4V 14-16, X-MAX RA ABS 125 4T-4V 14-16, XVS DRAG STAR 125 4T 04-04, X-CITY 250 4T 07-15, X-MAX 250 4T 07-09, X-MAX 250 4T 14-16, X-MAX ABS 250 4T 14-15, X-MAX BLACK 250 4T 09-09, XVS DRAG STAR 250 4T 01-03, YBR 250 4T 07-11, XVS A DRAG STAR CLASSIC 650 4T 98-01, XVS DRAG STAR 650 4T 97-02, BT BULLDOG 1100 4T 02-06, DRAG STAR CLASSIC XVS A 1100 4T 00-02, XVS DRAG STAR 1100 4T 99-02, XV A WILD STAR 1600 4T 99-02



◀ cod. **RE00024**
Regolatore di Tensione Derbi Senda X-Treme 50 cc

APPLICABILITÀ

APRILIA RS 50 2T 06-10, RS4 50 2T 11-13, RS4 REPLICA 50 2T 14-16, RX 50 2T 06-10, RX 50 2T 14-16, SX 50 2T 06-16, SX LIMITED EDITION 50 2T 14-16

DERBI GPR 2T 50 2T 13-13, GPR 2T EU2 50 2T 09-10, GPR NUDE 50 2T 04-05, GPR NUDE & GPR NUDE TUNING 50 2T 06-08, GPR NUDE SPORT 50 2T 06-06, GPR R EU2 - GPR REPLICA EU2 50 2T 08-08, GPR RACING 50 2T 04-05, GPR RACING EU2 50 2T 06-06, GPR REPLICA 50 2T 99-01, GPR REPLICA & GPR R EU2 50 2T 06-06, GPR REPLICA 2T MALOSSJ 50 2T 07-07, GPR REPLICA PESEK EU2 50 2T 07-07, GPR REPLICA RACING 50 2T 02-03, GPR REPLICA RACING EU2 50 2T 05-05, SENDA BLACK EDITION 50 2T 03-03, SENDA HYP DRD EVO EU2 50 2T 08-09, SENDA HYP DRD EVO LIMITED EDITION EU2 50 2T 08-08, SENDA R 50 2T 00-01, SENDA R DRD BLACK DEVIL 2A EDIZIONE 50 2T 03-03, SENDA R DRD EU1 EU1R 50 2T 02-02, SENDA R DRD PRO EU2 50 2T 05-11, SENDA R DRD RACING EU2 50 2T 05-08, SENDA R DRD X-TREME 2T EU2 50 2T 14-15, SENDA R DRD X-TREME 2T EURO2 50 2T 10-12, SENDA R RACER 50 2T 03-03, SENDA R X-RACE 50 2T 05-05, SENDA R X-RACE 2T EU2 50 2T 10-10, SENDA R X-RACE EU2 50 2T 06-09, SENDA R X-TREME 50 2T 03-03, SENDA R X-TREME 50 2T 05-05, SENDA R X-TREME 2T EU2 50 2T 10-10, SENDA R X-TREME EU2 50 2T 05-08, SENDA SM 50 2T 00-01, SENDA SM DRD EU1 EU1R 50 2T 02-03, SENDA SM DRD PRO EU2 50 2T 05-11, SENDA SM DRD PRO EU2 2VER 50 2T 05-08, SENDA SM DRD RACING EU2 50 2T 05-08, SENDA SM DRD RACING EU2 50 2T 10-13, SENDA SM DRD RACING LTD EU2 50 2T 07-07, SENDA SM DRD X-TREME 2T EU2 50 2T 14-15, SENDA SM DRD X-TREME 2T EU2 LIMITED ED 50 2T 14-15, SENDA SM X-RACE 50 2T 05-05, SENDA SM X-RACE 2T EU2 50 2T 10-10, SENDA SM X-RACE EU2 50 2T 06-09, SENDA SM X-RACE EU2 2VER 50 2T 07-09, SENDA SM X-TREME 50 2T 02-03, SENDA SM X-TREME 2T EU2 50 2T 10-10, SENDA SM X-TREME EU2 50 2T 07-08, SENDA SM X-TREME EU2 2A EDIZIONE 50 2T 05-05

GILERA RCR 50 2T 03-03, RCR 50 2T 06-07, RCR 50 2T 11-13, RCR (CHE-SYC) 50 2T 13-15, SMT 50 2T 03-03, SMT 50 2T 06-13, SMT RACING 50 2T 11-12



◀ cod. **RE00025**
Regolatore di Tensione Derbi Atlantis 50 cc

RIFERIMENTO ORIGINALE

Derbi	00G01001841
-------	-------------

APPLICABILITÀ

DERBI ATLANTIS 50 2T 99-01, ATLANTIS LC 50 2T 99-01, BULTACO LOBITO 50 2T 98-01, PREDATOR LC 50 2T 98-01, PREDATOR 02 50 2T 98-01, ATLANTIS 100 2T 00-01

PIAGGIO DIESIS 100 2T 01-01



◀ cod. **RE00026**
Regolatore di Tensione Kymco Dink 125/150 cc

RIFERIMENTO ORIGINALE

Kymco	00168780
-------	----------

APPLICABILITÀ

KYMCO B&W 125 4T 00-00, B&W EU2 125 4T 03-04, DINK 125 4T 97-98, DINK CLASSIC 125 4T 02-02, DINK CLASSIC EU2 125 4T 03-03, DINK LX 125 4T 98-00, GRAND DINK 125 4T 01-02, GRAND DINK EU2 125 4T 03-04, HEROISM 125 4T 95-97, B&W 150 4T 00-00, B&W EU2 150 4T 03-04, DINK 150 4T 97-98, DINK CLASSIC 150 4T 02-02, DINK CLASSIC EU2 150 4T 03-03, DINK LX 150 4T 98-00, GRAND DINK 150 4T 01-02, GRAND DINK EU2 150 4T 03-04, HEROISM 150 4T 95-97, DINK CLASSIC 200 4T 04-04, PEOPLE S I 200 4T 07-07, B&W 250 4T 00-00, B&W EU2 250 4T 03-03, GRAND DINK 250 4T 01-02, GRAND DINK EU2 250 4T 03-04, PEOPLE LC 250 4T 03-04, X CITING 250 4T 05-05, YUP 250 4T 03-03



◀ cod. **RE00028**
Regolatore di Tensione Kymco Dometown 300 cc



◀ cod. **RE00029**
Regolatore di Tensione Honda SH 300cc dal 2011



◀ cod. **RE00030**
Regolatore di Tensione Yamaha X-MAX 250 cc



◀ cod. **RE00031**
Regolatore di Tensione Honda SH 300 cc '07-'10



◀ cod. **RE00033**
Regolatore di tensione Yamaha T-Max 500/530 cc

APPLICABILITÀ

YAMAHA T-MAX 5VU 500 4T 04-07, T-MAX 5VU ABS 500 4T 05-07, T-MAX 5VU BLACK MAX 500 4T 06-06, T-MAX 5VU BLACK MAX - NIGHT MAX 500 4T 07-07, T-MAX 59C 530 4T 12-16, T-MAX 59C ABS 530 4T 12-16, T-MAX 59C SP 530 4T 15-15, T-MAX 59C SP ABS 530 4T 15-16, XP530-A T-MAX SX 530 4T 17-19, XP530D-A T-MAX DX 530 4T 17-19, XP530E-A T-MAX 530 4T 17-18, FZ6 600 4T 04-07, FZ6 FAZER 600 4T 04-07, FZ6 FAZER ABS 600 4T 06-07, FZ6 FAZER S2 600 4T 07-08, FZ6 FAZER S2 ABS 600 4T 08-08, FZ6 NS 600 4T 05-06, FZ6 S2 600 4T 07-08



◀ cod. **RE00034**
Regolatore Yamaha MT-09 '14-'17

APPLICABILITÀ

BMW F 750 GS (K80) 750 4T 16-18, F 850 GS (K81) 850 4T 16-18, R 1200 GS (K50) 1200 4T 11-18, R 1200 GS ADVENTURE (K51) 1200 4T 12-18, R 1200 R (K53) 1200 4T 13-18, R 1200 RS (K54) 1200 4T 14-18, R 1200 RT (K52) 1200 4T 13-18

HONDA TRX 420 FOURTRAX 420 4T 14-17, CB 500 F ABS 500 4T 13-17, CB 500 X ABS 500 4T 13-17, CBR 500 R ABS 500 4T 14-17, REBEL 500 4T 17-18, TRX 500 FOURTRAX 500 4T 14-17, CBR 600 RR ABS 600 4T 13-16, CB 650 F ABS 650 4T 14-17, CBR 650 F ABS 650 4T 14-17, CRF 1000 L AFRICA TWIN ABS 1000 4T 16-18, CB 1100 ABS 1100 4T 14-14, CB 1100 EX ABS 1100 4T 15-16

YAMAHA FZ8-N 800 4T 11-13, FZ8-N 800 4T 15-15, FZ8-NA 800 4T 11-13, FZ8-NA 800 4T 15-15, FZ8-S 800 4T 11-11, FZ8-S 800 4T 15-15, FZ8-SA 800 4T 11-15, MT-09 850 4T 14-15, MT-09 (MTN850-A) 850 4T 17-18, MT-09 SP (MTN850D) 850 4T 18-18, MT-09A ABS 850 4T 14-16, MT-09A TRACER 850 4T 15-17, XRS900 850 4T 16-18, SCR950 950 4T 17-17, XV950 950 4T 14-14, XV950 RACER 950 4T 15-16, XV950CU 950 4T 14-16, XV950R 950 4T 14-17, XVS950A MIDNIGHT STAR 950 4T 09-12, FZ1 1000 4T 06-09, FZ1 FAZER 1000 4T 06-12, FZ1 FAZER ABS 1000 4T 07-12, FZ1-N 1000 4T 11-11, FZ1-NA 1000 4T 10-11, YZF R1 1000 4T 07-14, XT1200Z SUPER TENERE 1200 4T 10-15, XT1200Z SUPER TENERE 1200 4T 17-17, XT1200ZE SUPER TENERE 1200 4T 14-15, XT1200ZE SUPER TENERE 1200 4T 17-17, FJR1300A 1300 4T 16-18, FJR1300A ABS 1300 4T 06-08, FJR1300A ABS 1300 4T 10-11, FJR1300A ABS 1300 4T 13-15, FJR1300AE 1300 4T 14-18, FJR1300AS 1300 4T 06-08, FJR1300AS 1300 4T 13-18, XVS1300A MIDNIGHT STAR 1300 4T 07-08, V-MAX 1700 4T 09-16, MT-01 1900 4T 09-09, MT-01S 1900 4T 09-09, XV1900A MIDNIGHT STAR 1900 4T 06-09, XV1900A MIDNIGHT STAR 1900 4T 13-13



◀ cod. **AC1003N**

Kymco Applications
12 Volt Regulator Rectifier Assembly

MAKE / MODEL	YEAR
Kymco Agility 125	2009-2013
Kymco Agility 50	2012-2014



◀ cod. **B1001N**

Aprilia / BMW Motorcycles
12 Volt Regulator Rectifier Assembly

MAKE / MODEL	YEAR
Aprilia Pegaso 650	1996-2000
BMW F650 Funduro	1993-2000



◀ cod. **H0502**

Harley-Davidson 38-48A Systems
12 Volt - Black finish

MAKE / MODEL	YEAR
Harley Davidson FLHRCI Road King Classic	2002
Harley Davidson FLHRI Road King	2002-2003
Harley Davidson FLTR Road Glide	2002
Harley Davidson FLTRI Road Glide	2002-2003



◀ cod. **H0502C**

Harley-Davidson 38-48A Systems
12 Volt - Chrome Finish

MAKE / MODEL	YEAR
Harley Davidson FLHRCI Road King Classic	2002
Harley Davidson FLHRI Road King	2002-2003
Harley Davidson FLTR Road Glide	2002
Harley Davidson FLTRI Road Glide	2002-2003



◀ **cod. H0505**
Harley-Davidson Systems
12 Volt Regulator Rectifier Assembly

MAKE / MODEL	YEAR
Harley Davidson FLHR Road King	2009-2014
Harley Davidson FLHRC Road King Classic	2009-2013
Harley Davidson FLHT Electra Glide Standard	2009
Harley Davidson FLHTC Electra Glide Classic	2009-2013
Harley Davidson FLHTCU Electra Glide Ultra Classic	2009-2013
Harley Davidson FLHTCUTG Tri Glide Ultra	2014
Harley Davidson FLHTCUTG Tri Glide Ultra Classic	2009-2013
Harley Davidson FLHTK Electra Glide Ultra Limited	2010-2013
Harley Davidson FLHTP Police	2012-2014
Harley Davidson FLHX Street Glide	2009-2013
Harley Davidson FLHXX Street Glide Trike	2010-2011
Harley Davidson FLTR Road Glide	2009
Harley Davidson FLTRU Road Glide Ultra	2011-2013
Harley Davidson FLTRX Road Glide Custom	2010-2013



◀ **cod. H0505C**
Harley-Davidson Systems
12 Volt Regulator Rectifier Assembly

MAKE / MODEL	YEAR
Harley Davidson FLHP Road King	2011-2014
Harley Davidson FLHR Road King	2009-2013
Harley Davidson FLHRC Road King Classic	2009-2013
Harley Davidson FLHT Electra Glide Standard	2009
Harley Davidson FLHTC Electra Glide Classic	2009-2013
Harley Davidson FLHTCU Electra Glide Ultra Classic	2009-2013
Harley Davidson FLHTCUTG Tri Glide Ultra	2014
Harley Davidson FLHTCUTG Tri Glide Ultra Classic	2009-2013
Harley Davidson FLHTK Electra Glide Ultra Limited	2010-2013
Harley Davidson FLHTP Police	2012-2014
Harley Davidson FLHX Street Glide	2009-2013
Harley Davidson FLHXX Street Glide Trike	2010-2011
Harley Davidson FLTR Road Glide	2009
Harley Davidson FLTRU Road Glide Ultra	2011-2013
Harley Davidson FLTRX Road Glide Custom	2010-2013



◀ **cod. H0506**
Harley-Davidson Systems
12 Volt - Black Finish

MAKE / MODEL	YEAR
Harley Davidson FLHP Road King	2007
Harley Davidson FLHR Road King	2006-2008
Harley Davidson FLHRC Road King Classic	2007-2008
Harley Davidson FLHRCI Road King Classic	2006-2008
Harley Davidson FLHRI Road King	2006-2008
Harley Davidson FLHRS Road King Custom	2006-2007
Harley Davidson FLHRSE4 Screamin Eagle Road King	2008
Harley Davidson FLHRSI Road King Custom	2006
Harley Davidson FLHT Electra Glide Standard	2006-2008

◀ **cod. H0506** - continued

MAKE / MODEL	YEAR
Harley Davidson FLHTC Electra Glide Classic	2007-2008
Harley Davidson FLHTCI Electra Glide Classic	2006-2008
Harley Davidson FLHTCU Electra Glide Ultra Classic	2007-2008
Harley Davidson FLHTCUI Electra Glide Ultra Classic	2006-2008
Harley Davidson FLHTI Electra Glide Standard	2007-2008
Harley Davidson FLHTP Police	2007
Harley Davidson FLHX Street Glide	2006-2008
Harley Davidson FLHXI Street Glide	2006
Harley Davidson FLTR Road Glide	2007-2008
Harley Davidson FLTRI Road Glide	2006-2008

◀ **cod. H0506C**
Harley-Davidson Systems
12 Volt - Chrome Finish



MAKE / MODEL	YEAR
Harley Davidson FLHP Road King	2007
Harley Davidson FLHR Road King	2006-2008
Harley Davidson FLHRC Road King Classic	2007-2008
Harley Davidson FLHRCI Road King Classic	2006-2008
Harley Davidson FLHRI Road King	2006-2008
Harley Davidson FLHRS Road King Custom	2006-2007
Harley Davidson FLHRSE4 Screamin Eagle Road King	2008
Harley Davidson FLHRSI Road King Custom	2006
Harley Davidson FLHT Electra Glide Standard	2006-2008
Harley Davidson FLHTC Electra Glide Classic	2007-2008
Harley Davidson FLHTCI Electra Glide Classic	2006-2008
Harley Davidson FLHTCU Electra Glide Ultra Classic	2007-2008
Harley Davidson FLHTCUI Electra Glide Ultra Classic	2006-2008
Harley Davidson FLHTI Electra Glide Standard	2007-2008
Harley Davidson FLHTP Police	2007
Harley Davidson FLHX Street Glide	2006-2008
Harley Davidson FLHXI Street Glide	2006
Harley Davidson FLTR Road Glide	2007-2008
Harley Davidson FLTRI Road Glide	2006-2008

◀ **cod. H0597**
Harley-Davidson Systems
12 Volt, Series-Type, 14.4 Vset



MAKE / MODEL	YEAR
Harley Davidson FLHRCI Road King Classic	1999-2001
Harley Davidson FLHRI Road King	2000-2001
Harley Davidson FLHTCI Electra Glide Classic	1997-2001
Harley Davidson FLHTCUI Electra Glide Ultra Classic	1997-2001
Harley Davidson FLHTI Electra Glide Standard	1997-2001
Harley Davidson FLTR Road Glide	1999-2001
Harley Davidson FLTRI Road Glide	1999-2001



◀ **cod. H0597C**
Harley-Davidson Systems
12 Volt, Series-Type, 14.4 Vset

MAKE / MODEL	YEAR
Harley Davidson FLHRCI Road King Classic	1999-2001
Harley Davidson FLHRI Road King	2000-2001
Harley Davidson FLHTCI Electra Glide Classic	1997-2001
Harley Davidson FLHTCUI Electra Glide Ultra Classic	1997-2001
Harley Davidson FLHTI Electra Glide Standard	1997-2001
Harley Davidson FLTR Road Glide	1999-2001
Harley Davidson FLTRI Road Glide	1999-2001



◀ **cod. H1001**
Harley-Davidson Systems
12 Volt, Series-Type, 14.4 Vset

MAKE / MODEL	YEAR
Harley Davidson FLSTCI Heritage Softail Classic	2001-2006
Harley Davidson FLSTFSE Screamin Eagle Fat Boy	2005
Harley Davidson FLSTFSE2 Screamin Eagle Fat Boy	2006
Harley Davidson FLSTI Heritage Softail	2006
Harley Davidson FLSTNI Softail Deluxe	2005-2006
Harley Davidson FLSTSCI Softail Springer Classic	2005-2006
Harley Davidson FXSTDI Softail Deuce	2001-2006
Harley Davidson FXSTI Softail Standard	2001-2006
Harley Davidson FXSTSI Springer Softail	2001-2006



◀ **cod. H1001C**
Harley-Davidson Systems
12 Volt, Series-Type, 14.4 Vset

MAKE / MODEL	YEAR
Harley Davidson FLSTCI Heritage Softail Classic	2001-2006
Harley Davidson FLSTFSE Screamin Eagle Fat Boy	2005
Harley Davidson FLSTFSE2 Screamin Eagle Fat Boy	2006
Harley Davidson FLSTI Heritage Softail	2006
Harley Davidson FLSTNI Softail Deluxe	2005-2006
Harley Davidson FLSTSCI Softail Springer Classic	2005-2006
Harley Davidson FXSTDI Softail Deuce	2001-2006
Harley Davidson FXSTI Softail Standard	2001-2006
Harley Davidson FXSTSI Springer Softail	2001-2006



◀ **cod. H1070**
Harley-Davidson 15A Systems
12 Volt, Shunt Type, 14.5 Vset

MAKE / MODEL	YEAR
Harley Davidson FLH Electra Glide	1970-1975
Harley Davidson FLHF	1970-1972
Harley Davidson FX Super Glide	1971-1975
Harley Davidson FXE Super Glide	1974-1975
Harley Davidson XLCH	1972-1975
Harley Davidson XLH1000	1972-1975
Harley Davidson XLH900	1971



◀ **cod. H1070C**
Harley-Davidson 15A Systems
12 Volt, Shunt Type, 14.5 Vset

MAKE / MODEL	YEAR
Harley Davidson FLH Electra Glide	1970-1975
Harley Davidson FLHF	1970-1972
Harley Davidson FX Super Glide	1971-1975
Harley Davidson FXE Super Glide	1974-1975
Harley Davidson XLCH	1972-1975
Harley Davidson XLH1000	1972-1975
Harley Davidson XLH900	1971



◀ **cod. H1075**
Harley-Davidson 17.8A Systems
12 Volt, Shunt-Type, 14.5 Vset

MAKE / MODEL	YEAR
Harley Davidson FLH Electra Glide	1976-1980
Harley Davidson FLT Tour Glide	1980



◀ **cod. H1075C**
Harley-Davidson 17.8A System
12 Volt, Shunt-Type, 14.5 Vset

MAKE / MODEL	YEAR
Harley Davidson FLH Electra Glide	1976-1980
Harley Davidson FLT Tour Glide	1980



◀ **cod. H1108**
Harley-Davidson 32A Systems
12 Volt Regulator Rectifier Assembly

MAKE / MODEL	YEAR
Harley Davidson XL1200C Sportster 1200 Custom	2009-2013
Harley Davidson XL1200CA 1200 Custom Limited A	2013
Harley Davidson XL1200CB 1200 Custom Limited B	2013
Harley Davidson XL1200CP 1200 Custom	2011-2013
Harley Davidson XL1200L Sportster 1200 Low	2009-2010
Harley Davidson XL1200N Sportster 1200 Nightster	2009-2012
Harley Davidson XL1200R Sportster 1200 Roadster	2009
Harley Davidson XL1200V Seventy-Two	2012-2013
Harley Davidson XL1200X Forty-Eight	2011-2013
Harley Davidson XL883 Sportster	2009
Harley Davidson XL883C Sportster 883 Custom	2009-2010
Harley Davidson XL883L Sportster 883 Low	2009-2010
Harley Davidson XL883L SuperLow	2011-2013
Harley Davidson XL883N Iron 883	2009-2013
Harley Davidson XL883R Sportster 883 Roadster	2009-2013
Harley Davidson XLR1200X 1200X	2011-2013
Harley Davidson XR1200	2009-2010
Harley Davidson XR1200X	2010



◀ **cod. H1108C**
Harley-Davidson 32A Systems
12 Volt Regulator Rectifier Assembly

MAKE / MODEL	YEAR
Harley Davidson XL1200C Sportster 1200 Custom	2009-2013
Harley Davidson XL1200CA 1200 Custom Limited A	2013
Harley Davidson XL1200CB 1200 Custom Limited B	2013
Harley Davidson XL1200CP 1200 Custom	2011-2013
Harley Davidson XL1200L Sportster 1200 Low	2009-2010
Harley Davidson XL1200N Sportster 1200 Nightster	2009-2012
Harley Davidson XL1200R Sportster 1200 Roadster	2009
Harley Davidson XL1200V Seventy-Two	2012-2013
Harley Davidson XL1200X Forty-Eight	2011-2013
Harley Davidson XL883 Sportster	2009
Harley Davidson XL883C Sportster 883 Custom	2009-2010
Harley Davidson XL883L Sportster 883 Low	2009-2010
Harley Davidson XL883L SuperLow	2011-2013
Harley Davidson XL883N Iron 883	2009-2013
Harley Davidson XL883R Sportster 883 Roadster	2009-2013
Harley Davidson XLR1200X 1200X	2011-2013
Harley Davidson XR1200	2009-2010
Harley Davidson XR1200X	2010



◀ **cod. H1200**
Harley-Davidson Systems
12 Volt, Shunt-Type, 14.5 Vset

MAKE / MODEL	YEAR
Harley Davidson FLSTCI Heritage Softail Classic	2000
Harley Davidson FLSTFI Fat Boy	2000
Harley Davidson FLSTSI Heritage Springer	2000
Harley Davidson FXSTBI Night Train	2000
Harley Davidson FXSTDI Softail Deuce	2000
Harley Davidson FXSTI Softail Standard	2000
Harley Davidson FXSTSI Springer Softail	2000



◀ **cod. H1200C**
Harley-Davidson Systems
12 Volt, Shunt-Type, 14.5 Vset

MAKE / MODEL	YEAR
Harley Davidson FLSTCI Heritage Softail Classic	2000
Harley Davidson FLSTFI Fat Boy	2000
Harley Davidson FLSTSI Heritage Springer	2000
Harley Davidson FXSTBI Night Train	2000
Harley Davidson FXSTDI Softail Deuce	2000
Harley Davidson FXSTI Softail Standard	2000
Harley Davidson FXSTSI Springer Softail	2000



◀ **cod. H1686**
Harley-Davidson 22A Systems
12 Volt, Shunt-Type, 14.5 Vset

MAKE / MODEL	YEAR
Harley Davidson FLH Electra Glide	1981-1985
Harley Davidson FLHC Electra Glide Classic	1981
Harley Davidson FLHS Electra Glide Sport	1981-1988
Harley Davidson FLHTCI Electra Glide Classic	1983-1988
Harley Davidson FLHTI Electra Glide Standard	1986-1987
Harley Davidson FLHX Electra Glide Special	1984-1985
Harley Davidson FXDG Disc Glide	1983
Harley Davidson FXR Super Glide II	1982-1988
Harley Davidson FXRC Low Rider Chrome	1985-1987
Harley Davidson FXRD Sport Glide Grand Touring	1986
Harley Davidson FXRDG Disc Glide	1984
Harley Davidson FXRS Low Glide	1982-1988
Harley Davidson FXRS-SP Low Rider Sport	1986-1988
Harley Davidson FXRT Sport Glide	1983-1988



◀ **cod. H1899**
Harley-Davidson Systems
12 Volt, Shunt-Type, 14.5 Vset

MAKE / MODEL	YEAR
Harley Davidson FXDI Dyna Super Glide	1999-2003
Harley Davidson FXDLI Dyna Low Rider	1999-2003
Harley Davidson FXDS-Conv Dyna Convertible	1999-2000
Harley Davidson FXDWGI Dyna Wide Glide	1999-2003
Harley Davidson FXDX Dyna Super Glide Sport	1999-2003
Harley Davidson FXDXT Dyna Super Glide T-Sport	2001-2003



◀ **cod. H1899C**
Harley-Davidson Systems
12 Volt, Shunt-Type, 14.5 Vset

MAKE / MODEL	YEAR
Harley Davidson FXDI Dyna Super Glide	1999-2003
Harley Davidson FXDLI Dyna Low Rider	1999-2003
Harley Davidson FXDS-Conv Dyna Convertible	1999-2000
Harley Davidson FXDWGI Dyna Wide Glide	1999-2003
Harley Davidson FXDX Dyna Super Glide Sport	1999-2003
Harley Davidson FXDXT Dyna Super Glide T-Sport	2001-2003



◀ **cod. H1988**
Harley-Davidson 32A Systems
12 Volt, Shunt-Type, 14.5 Vset

MAKE / MODEL	YEAR
Harley Davidson FLHRCI Road King Classic	1998
Harley Davidson FLHRI Road King	1996-1997
Harley Davidson FLHS Electra Glide Sport	1989-1993
Harley Davidson FLHTCI Electra Glide Classic	1989-1996
Harley Davidson FLHTCUI Electra Glide Ultra Classic	1989-1996

◀ **cod. H1988** - continued

MAKE / MODEL	YEAR
Harley Davidson FLHTI Electra Glide Standard	1995-1998
Harley Davidson FLSTCI Heritage Softail Classic	1989-1998
Harley Davidson FLSTI Heritage Softail	1989-1990
Harley Davidson FLSTNI Softail Deluxe	1993-1996
Harley Davidson FLSTSI Heritage Springer	1997-1998
Harley Davidson FLTC/I Tour Glide Classic	1989-1991
Harley Davidson FLTCUI Tour Glide Ultra Classic	1989-1996
Harley Davidson FLTRI Road Glide	1998
Harley Davidson FXDI Dyna Super Glide	1995-1998
Harley Davidson FXDLI Dyna Low Rider	1993-1998
Harley Davidson FXDWGI Dyna Wide Glide	1993-1998
Harley Davidson FXLR Low Rider Custom	1989-1994
Harley Davidson FXR Super Glide II	1989-1994
Harley Davidson FXR2	1999
Harley Davidson FXR3	1999
Harley Davidson FXRS Low Glide	1989-1992
Harley Davidson FXRS-Conv Low Rider Sport Convertible	1990-1993
Harley Davidson FXRS-SP Low Rider Sport	1989-1993
Harley Davidson FXRT Sport Glide	1989-1992
Harley Davidson FXSTBI Night Train	1999
Harley Davidson FXSTC Softail Custom	1989-1999
Harley Davidson FXSTI Softail Standard	1989-1991
Harley Davidson FXSTSB Bad Boy	1995-1997
Harley Davidson FXSTSI Springer Softail	1989-1999



◀ **cod. H1988C**
Harley-Davidson 32A Systems
 12 Volt, Shunt-Type, 14.5 Vset

MAKE / MODEL	YEAR
Harley Davidson FLHRCI Road King Classic	1998
Harley Davidson FLHRI Road King	1996-1997
Harley Davidson FLHS Electra Glide Sport	1989-1993
Harley Davidson FLHTCI Electra Glide Classic	1989-1996
Harley Davidson FLHTCUI Electra Glide Ultra Classic	1989-1996
Harley Davidson FLHTI Electra Glide Standard	1995-1998
Harley Davidson FLSTCI Heritage Softail Classic	1989-1998
Harley Davidson FLSTI Heritage Softail	1989-1990
Harley Davidson FLSTNI Softail Deluxe	1993-1996
Harley Davidson FLSTSI Heritage Springer	1997-1998
Harley Davidson FLTC/I Tour Glide Classic	1989-1991
Harley Davidson FLTCUI Tour Glide Ultra Classic	1989-1996
Harley Davidson FLTRI Road Glide	1998
Harley Davidson FXDI Dyna Super Glide	1995-1998
Harley Davidson FXDLI Dyna Low Rider	1993-1998
Harley Davidson FXDWGI Dyna Wide Glide	1993-1998
Harley Davidson FXLR Low Rider Custom	1989-1994
Harley Davidson FXR Super Glide II	1989-1994
Harley Davidson FXR2	1999
Harley Davidson FXR3	1999
Harley Davidson FXRS Low Glide	1989-1992
Harley Davidson FXRS-Conv Low Rider Sport Convertible	1990-1993

◀ cod. **H1988C** - continued

MAKE / MODEL	YEAR
Harley Davidson FXRS-SP Low Rider Sport	1989-1993
Harley Davidson FXRT Sport Glide	1989-1992
Harley Davidson FXSTBI Night Train	1999
Harley Davidson FXSTC Softail Custom	1989-1999
Harley Davidson FXSTI Softail Standard	1989-1991
Harley Davidson FXSTSB Bad Boy	1995-1997
Harley Davidson FXSTSI Springer Softail	1989-1999



◀ cod. **H2304**

Harley-Davidson 22A Systems
12 Volt Regulator Rectifier Assembly

MAKE / MODEL	YEAR
Harley Davidson XL1200C Sportster 1200 Custom	2004-2006
Harley Davidson XL1200L Sportster 1200 Low	2006
Harley Davidson XL1200R Sportster 1200 Roadster	2004-2006
Harley Davidson XL883 Sportster	2004-2006
Harley Davidson XL883C Sportster 883 Custom	2004-2006
Harley Davidson XL883L Sportster 883 Low	2005-2006
Harley Davidson XL883R Sportster 883 Roadster	2005-2006



◀ cod. **H2304C**

Harley-Davidson 22A Systems
12 Volt Regulator Rectifier Assembly

MAKE / MODEL	YEAR
Harley Davidson XL1200C Sportster 1200 Custom	2004-2006
Harley Davidson XL1200L Sportster 1200 Low	2006
Harley Davidson XL1200R Sportster 1200 Roadster	2004-2006
Harley Davidson XL883 Sportster	2004-2006
Harley Davidson XL883C Sportster 883 Custom	2004-2006
Harley Davidson XL883L Sportster 883 Low	2005-2006
Harley Davidson XL883R Sportster 883 Roadster	2005-2006



◀ cod. **H2384**

Harley-Davidson Systems
12 Volt, Shunt-Type, 14.5 Vset

MAKE / MODEL	YEAR
Harley Davidson XLH1000	1984-1985
Harley Davidson XLH1100	1986
Harley Davidson XLH883	1986
Harley Davidson XLH883DLX Sportster 883 Deluxe	1986
Harley Davidson XLX 1000	1984-1985
Harley Davidson XR1000	1984-1985



◀ **cod. H2386**
Harley-Davidson 19A Systems
12 Volt, Shunt-Type, 14.5 Vset

MAKE / MODEL	YEAR
Harley Davidson XLH1100	1986-1987
Harley Davidson XLH1200	1988-1990
Harley Davidson XLH883	1986-1990
Harley Davidson XLH883DLX Sportster 883 Deluxe	1986-1990
Harley Davidson XLH883HUG Sportster 883 Hugger	1987-1990



◀ **cod. H2386C**
Harley-Davidson 19A Systems
12 Volt, Shunt-Type, 14.5 Vset

MAKE / MODEL	YEAR
Harley Davidson XLH1100	1986-1987
Harley Davidson XLH1200	1988-1990
Harley Davidson XLH883	1986-1990
Harley Davidson XLH883DLX Sportster 883 Deluxe	1986-1990
Harley Davidson XLH883HUG Sportster 883 Hugger	1987-1990



◀ **cod. H2391**
Harley-Davidson 32A Systems
12 Volt, Shunt-Type, 14.5 Vset

MAKE / MODEL	YEAR
Harley Davidson XLH1200	1991
Harley Davidson XLH883	1991
Harley Davidson XLH883DLX Sportster 883 Deluxe	1991
Harley Davidson XLH883HUG Sportster 883 Hugger	1991



◀ **cod. H2391C**
Harley-Davidson 32A Systems
12 Volt, Shunt-Type, 14.5 Vset

MAKE / MODEL	YEAR
Harley Davidson XLH1200	1991
Harley Davidson XLH883	1991
Harley Davidson XLH883DLX Sportster 883 Deluxe	1991
Harley Davidson XLH883HUG Sportster 883 Hugger	1991



◀ **cod. H2392**
Harley-Davidson Systems
12 Volt, Shunt-Type, 14.5 Vset

MAKE / MODEL	YEAR
Harley Davidson XLH1200	1992-1993
Harley Davidson XLH883	1992-1993
Harley Davidson XLH883DLX Sportster 883 Deluxe	1992-1993
Harley Davidson XLH883HUG Sportster 883 Hugger	1992-1993



◀ **cod. H2392C**
Harley-Davidson Systems
12 Volt, Shunt-Type, 14.5 Vset

MAKE / MODEL	YEAR
Harley Davidson XLH1200	1992-1993
Harley Davidson XLH883	1992-1993
Harley Davidson XLH883DLX Sportster 883 Deluxe	1992-1993
Harley Davidson XLH883HUG Sportster 883 Hugger	1992-1993



◀ **cod. H2394**
Harley-Davidson Systems
12 Volt, Shunt-Type, 14.5 Vset

MAKE / MODEL	YEAR
Harley Davidson XL1200C Sportster 1200 Custom	1996-2003
Harley Davidson XL1200S Sportster 1200 Sport	1996-2003
Harley Davidson XL883C Sportster 883 Custom	1998-2003
Harley Davidson XL883R Sportster 883 Roadster	2002-2003
Harley Davidson XLH1200	1994-2003
Harley Davidson XLH883	1994-2003
Harley Davidson XLH883DLX Sportster 883 Deluxe	1994-1995
Harley Davidson XLH883HUG Sportster 883 Hugger	1994-2003



◀ **cod. H2394C**
Harley-Davidson Systems
12 Volt, Shunt-Type, 14.5 Vset

MAKE / MODEL	YEAR
Harley Davidson XL1200C Sportster 1200 Custom	1996-2003
Harley Davidson XL1200S Sportster 1200 Sport	1996-2003
Harley Davidson XL883C Sportster 883 Custom	1998-2003
Harley Davidson XL883R Sportster 883 Roadster	2002-2003
Harley Davidson XLH1200	1994-2003
Harley Davidson XLH883	1994-2003
Harley Davidson XLH883DLX Sportster 883 Deluxe	1994-1995
Harley Davidson XLH883HUG Sportster 883 Hugger	1994-2003



◀ **cod. H3104**
Harley-Davidson 32A, Three-Phase Systems
12 Volt Regulator Rectifier Assembly

MAKE / MODEL	YEAR
Harley Davidson FXD Dyna Super Glide	2005
Harley Davidson FXDC Super Glide Custom	2005
Harley Davidson FXDCI Super Glide Custom	2005
Harley Davidson FXDI Dyna Super Glide	2004-2005
Harley Davidson FXDL Dyna Low Rider	2005
Harley Davidson FXDLI Dyna Low Rider	2004-2005
Harley Davidson FXDWG Dyna Wide Glide	2005
Harley Davidson FXDWGI Dyna Wide Glide	2004-2005
Harley Davidson FXDX Dyna Super Glide Sport	2004-2005
Harley Davidson FXDXI Dyna Super Glide Sport	2004-2005





◀ **cod. H3104C**
Harley-Davidson 32A, Three-Phase Systems
12 Volt Regulator Rectifier Assembly

MAKE / MODEL	YEAR
Harley Davidson FXD Dyna Super Glide	2005
Harley Davidson FXDC Super Glide Custom	2005
Harley Davidson FXDCI Super Glide Custom	2005
Harley Davidson FXDI Dyna Super Glide	2004-2005
Harley Davidson FXDL Dyna Low Rider	2005
Harley Davidson FXDLI Dyna Low Rider	2004-2005
Harley Davidson FXDWG Dyna Wide Glide	2005
Harley Davidson FXDWGI Dyna Wide Glide	2004-2005
Harley Davidson FXDX Dyna Super Glide Sport	2004-2005
Harley Davidson FXDXI Dyna Super Glide Sport	2004-2005



◀ **cod. H3106**
Harley-Davidson 38A, Three-Phase Systems
12 Volt Regulator Rectifier Assembly

MAKE / MODEL	YEAR
Harley Davidson FXD Dyna Super Glide	2007
Harley Davidson FXD35 Super Golden Anniversary	2006
Harley Davidson FXDB Street Bob	2007
Harley Davidson FXDBA Street Bob	2006
Harley Davidson FXDBI Street Bob	2006
Harley Davidson FXDC Super Glide Custom	2007
Harley Davidson FXDCI Super Glide Custom	2006
Harley Davidson FXDI Dyna Super Glide	2006-2007
Harley Davidson FXDI35 Dyna 35th Anniversary Super Glide	2006
Harley Davidson FXDL Dyna Low Rider	2006-2007
Harley Davidson FXDLI Dyna Low Rider	2006-2007
Harley Davidson FXDSE Screamin Eagle Dyna	2007
Harley Davidson FXDWG Dyna Wide Glide	2007
Harley Davidson FXDWGI Dyna Wide Glide	2006-2007



◀ **cod. H3106C**
Harley-Davidson 38A, Three-Phase Systems
12 Volt Regulator Rectifier Assembly

MAKE / MODEL	YEAR
Harley Davidson FXD Dyna Super Glide	2007
Harley Davidson FXD35 Super Golden Anniversary	2006
Harley Davidson FXDB Street Bob	2007
Harley Davidson FXDBA Street Bob	2006
Harley Davidson FXDBI Street Bob	2006
Harley Davidson FXDC Super Glide Custom	2007
Harley Davidson FXDCI Super Glide Custom	2006
Harley Davidson FXDI Dyna Super Glide	2006-2007
Harley Davidson FXDI35 Dyna 35th Anniversary Super Glide	2006
Harley Davidson FXDL Dyna Low Rider	2006-2007
Harley Davidson FXDLI Dyna Low Rider	2006-2007
Harley Davidson FXDSE Screamin Eagle Dyna	2007
Harley Davidson FXDWG Dyna Wide Glide	2007
Harley Davidson FXDWGI Dyna Wide Glide	2006-2007



◀ **cod. H3108**
Harley-Davidson 40A, Three-Phase Systems
12 Volt Regulator Rectifier Assembly

MAKE / MODEL	YEAR
Harley Davidson FLD Switchback	2012-2014
Harley Davidson FXD Dyna Super Glide	2008-2010
Harley Davidson FXDB Street Bob	2009-2014
Harley Davidson FXDBA Street Bob	2013
Harley Davidson FXDBP Street Bob	2013-2014
Harley Davidson FXDC Super Glide Custom	2008-2014
Harley Davidson FXDF Fat Bob	2008-2014
Harley Davidson FXDFSE CVO Dyna Fat Bob	2009
Harley Davidson FXDI Dyna Super Glide	2008-2009
Harley Davidson FXDL Dyna Low Rider	2008-2011
Harley Davidson FXDLI Dyna Low Rider	2008-2009
Harley Davidson FXDSE2 Screamin Eagle Dyna	2008
Harley Davidson FXDWG Dyna Wide Glide	2008-2014
Harley Davidson FXDWGI Dyna Wide Glide	2008



◀ **cod. H3108C**
Harley-Davidson 40A, Three-Phase Systems
12 Volt Regulator Rectifier Assembly

MAKE / MODEL	YEAR
Harley Davidson FLD Switchback	2012-2014
Harley Davidson FXD Dyna Super Glide	2008-2010
Harley Davidson FXDB Street Bob	2008-2014
Harley Davidson FXDBA Street Bob	2013
Harley Davidson FXDBP Street Bob	2013-2014
Harley Davidson FXDC Super Glide Custom	2008-2014
Harley Davidson FXDF Fat Bob	2008-2014
Harley Davidson FXDFSE CVO Dyna Fat Bob	2009
Harley Davidson FXDI Dyna Super Glide	2008-2009
Harley Davidson FXDL Dyna Low Rider	2008-2011
Harley Davidson FXDLI Dyna Low Rider	2008-2009
Harley Davidson FXDSE2 Screamin Eagle Dyna	2008
Harley Davidson FXDWG Dyna Wide Glide	2008-2014
Harley Davidson FXDWGI Dyna Wide Glide	2008



◀ **cod. H4007**
Harley-Davidson 40A, Three-Phase Systems
12 Volt Regulator Rectifier Assembly

MAKE / MODEL	YEAR
Harley Davidson FLSTC Heritage Softail Classic	2007
Harley Davidson FLSTCI Heritage Softail Classic	2007
Harley Davidson FLSTF Fat Boy	2007
Harley Davidson FLSTFI Fat Boy	2007
Harley Davidson FLSTN Softail Deluxe	2007
Harley Davidson FLSTNI Softail Deluxe	2007
Harley Davidson FLSTSC Softail Springer Classic	2007
Harley Davidson FLSTSCI Softail Springer Classic	2007

◀ **cod. H4007** - continued

MAKE / MODEL	YEAR
Harley Davidson FXST Softail Standard	2007
Harley Davidson FXSTB Night Train	2007
Harley Davidson FXSTBI Night Train	2007
Harley Davidson FXSTC Softail Custom	2007
Harley Davidson FXSTD Softail Deuce	2007
Harley Davidson FXSTDI Softail Deuce	2007
Harley Davidson FXSTI Softail Standard	2007
Harley Davidson FXSTSSE Screamin Eagle Softail Springer	2007



◀ **cod. H4007C**
Harley-Davidson 40A, Three-Phase Systems
12 Volt Regulator Rectifier Assembly

MAKE / MODEL	YEAR
Harley Davidson FLSTC Heritage Softail Classic	2007
Harley Davidson FLSTCI Heritage Softail Classic	2007
Harley Davidson FLSTF Fat Boy	2007
Harley Davidson FLSTFI Fat Boy	2007
Harley Davidson FLSTN Softail Deluxe	2007
Harley Davidson FLSTNI Softail Deluxe	2007
Harley Davidson FLSTSC Softail Springer Classic	2007
Harley Davidson FLSTSCI Softail Springer Classic	2007
Harley Davidson FXST Softail Standard	2007
Harley Davidson FXSTB Night Train	2007
Harley Davidson FXSTBI Night Train	2007
Harley Davidson FXSTC Softail Custom	2007
Harley Davidson FXSTD Softail Deuce	2007
Harley Davidson FXSTDISoftail Deuce	2007
Harley Davidson FXSTI Softail Standard	2007
Harley Davidson FXSTSSE Screamin Eagle Softail Springer	2007

◀ **cod. H4008**
Harley-Davidson 40A, Three-Phase Systems
12 Volt Regulator Rectifier Assembly



MAKE / MODEL	YEAR
Harley Davidson FLSTB Softail Fat Boy Special	2010
Harley Davidson FLSTC Heritage Softail Classic	2008-2010
Harley Davidson FLSTCI Heritage Softail Classic	2008-2009
Harley Davidson FLSTF Fat Boy	2008-2010
Harley Davidson FLSTFI Fat Boy	2008-2009
Harley Davidson FLSTN Softail Deluxe	2008-2010
Harley Davidson FLSTNI Softail Deluxe	2008-2009
Harley Davidson FLSTSB Cross Bones	2008-2010
Harley Davidson FXCW Rocker	2008-2009
Harley Davidson FXCWC Rocker C	2008-2010
Harley Davidson FXST Softail Standard	2008
Harley Davidson FXSTB Night Train	2008
Harley Davidson FXSTBI Night Train	2008-2009
Harley Davidson FXSTC Softail Custom	2008-2010
Harley Davidson FXSTSSE2 Screamin Eagle Softail Springer	2008
Harley Davidson FXSTSSE3 CVO Softail Springer	2009



◀ **cod. H4008C**
 Harley-Davidson 40A, Three-Phase Systems
 12 Volt Regulator Rectifier Assembly

MAKE / MODEL	YEAR
Harley Davidson FLSTB Softail Fat Boy Special	2010
Harley Davidson FLSTC Heritage Softail Classic	2008-2010
Harley Davidson FLSTCI Heritage Softail Classic	2008-2009
Harley Davidson FLSTF Fat Boy	2008-2010
Harley Davidson FLSTFI Fat Boy	2008-2009
Harley Davidson FLSTN Softail Deluxe	2008-2010
Harley Davidson FLSTNI Softail Deluxe	2008-2009
Harley Davidson FLSTSB Cross Bones	2008-2010
Harley Davidson FXCW Rocker	2008-2009
Harley Davidson FXCWC Rocker C	2008-2010
Harley Davidson FXST Softail Standard	2008
Harley Davidson FXSTB Night Train	2008
Harley Davidson FXSTBI Night Train	2008-2009
Harley Davidson FXSTC Softail Custom	2008-2010
Harley Davidson FXSTSSE2 Screamin Eagle Softail Springer	2008
Harley Davidson FXSTSSE3 CVO Softail Springer	2009



◀ **cod. H4408**
 Harley Davidson Motorcycle
 12 Volt Regulator Rectifier Assembly

MAKE / MODEL	YEAR
Harley Davidson VRSCAW V-Rod	2008-2010
Harley Davidson VRSCD Night Rod	2008
Harley Davidson VRSCDX ANN V-Rod Anniversary Edition	2012
Harley Davidson VRSCDX Night Rod Special	2008-2014
Harley Davidson VRSCF V-Rod Muscle	2009-2014



◀ **cod. H4408C**
 Harley Davidson Motorcycle
 12 Volt Regulator Rectifier Assembly

MAKE / MODEL	YEAR
Harley Davidson VRSCAW V-Rod	2008-2010
Harley Davidson VRSCD Night Rod	2008
Harley Davidson VRSCDX ANN V-Rod Anniversary Edition	2012
Harley Davidson VRSCDX Night Rod Special	2008-2014
Harley Davidson VRSCF V-Rod Muscle	2009-2014



◀ **cod. H4607**
Harley-Davidson 32A Systems
12 Volt Regulator Rectifier Assembly

MAKE / MODEL	YEAR
Harley Davidson XL1200C Sportster 1200 Custom	2007-2008
Harley Davidson XL1200L Sportster 1200 Low	2007-2008
Harley Davidson XL1200N Sportster 1200 Nightster	2007-2008
Harley Davidson XL1200R Sportster 1200 Roadster	2007-2008
Harley Davidson XL50 50th Anniversary Sportster	2007
Harley Davidson XL883 Sportster	2007-2008
Harley Davidson XL883C Sportster 883 Custom	2007-2008
Harley Davidson XL883L Sportster 883 Low	2007-2008
Harley Davidson XL883R Sportster 883 Roadster	2007-2008



◀ **cod. H4607C**
Harley-Davidson 32A Systems
12 Volt Regulator Rectifier Assembly

MAKE / MODEL	YEAR
Harley Davidson XL1200C Sportster 1200 Custom	2007-2008
Harley Davidson XL1200L Sportster 1200 Low	2007-2008
Harley Davidson XL1200N Sportster 1200 Nightster	2007-2008
Harley Davidson XL1200R Sportster 1200 Roadster	2007-2008
Harley Davidson XL50 50th Anniversary Sportster	2007
Harley Davidson XL883 Sportster	2007-2008
Harley Davidson XL883C Sportster 883 Custom	2007-2008
Harley Davidson XL883L Sportster 883 Low	2007-2008
Harley Davidson XL883R Sportster 883 Roadster	2007-2008



◀ **cod. HN1004N**
Honda Applications
12 Volt Regulator Rectifier Assembly

MAKE / MODEL	YEAR
Honda CRF230F	2003-2004
Honda SA50 Elite SR	1994-2001
Honda SA50P Elite S	1994-2001



◀ **cod. HN1005N**
Honda Applications
12 Volt Regulator Rectifier Assembly

MAKE / MODEL	YEAR
Honda CBR900RR	2002-2003



◀ cod. **HN1006N**

Honda Applications

12 Volt Regulator Rectifier Assembly

MAKE / MODEL	YEAR
Honda CBR1000RR	2008-2013
Honda NC700X	2012



◀ cod. **HN1007N**

Honda Applications

12 Volt Regulator Rectifier Assembly

MAKE / MODEL	YEAR
Honda NTV650V	1998-2005
Honda VT125 Shadow	2001-2007
Husqvarna SMS 125	2011-2013
Husqvarna TE250	2008-2012
Husqvarna TE310	2011-2012
Husqvarna TXC 250	2008-2012
Husqvarna WRE 125	2011-2013

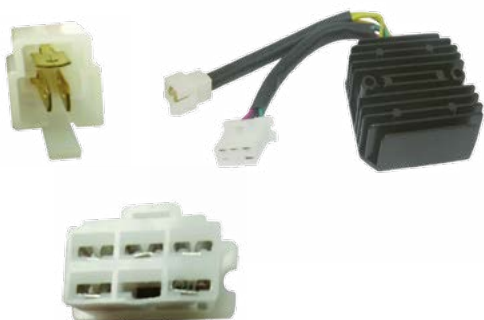
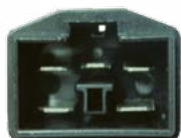

◀ cod. **HN1008N**

Honda Applications

12 Volt Regulator Rectifier Assembly

MAKE / MODEL	YEAR
Honda NX650	1988-1989



◀ cod. **HN1009N**

Honda Applications

12 Volt Regulator Rectifier Assembly

MAKE / MODEL	YEAR
Honda CBR1000RR	2004-2005



◀ **cod. HN1010N**
Honda Applications
12 Volt Regulator Rectifier Assembly

MAKE / MODEL	YEAR
Aprilia RXV 450	2006-2012
Aprilia RXV 550	2006-2012
Aprilia SXV 450	2006-2012
Aprilia SXV 550	2006-2012
Honda CB250 Nighthawk	1991-2001
Honda CB600F 599	2004-2006
Honda FES250 Foresight	1998-2005
Honda NSS250 Reflex	2001-2003
Honda NSS250A Reflex ABS	2001-2003
Honda VT750C Shadow Aero	2001
Honda VT750C/CD Shadow ACE	2002-2003



◀ **cod. HN1011N**
Honda Applications
12 Volt Regulator Rectifier Assembly

MAKE / MODEL	YEAR
Honda CBR600F	1990
Honda CBR600F Hurricane	1987-1989



◀ **cod. HN1012N**
Honda Applications
12 Volt Regulator Rectifier Assembly

MAKE / MODEL	YEAR
Honda SH300iA	2007-2010
Honda SH300iR	2008-2010



◀ **cod. HN1014N**
Honda Applications
12 Volt Regulator Rectifier Assembly

MAKE / MODEL	YEAR
Honda CB1000	1994-1995
Honda CB750 Nighthawk	1991-2003
Honda CBR1000F	1993-1996
Honda CBR1000F Hurricane	1990-1991
Honda ST1100	1991-1995
Honda ST1100 ABS	1992-1995



◀ **cod. HN1015N**
Honda Applications
12 Volt Regulator Rectifier Assembly

MAKE / MODEL	YEAR
Honda TRX350FE FourTrax Rancher 4x4 ES	2000-2003
Honda TRX350FM FourTrax Rancher 4X4	2000-2003
Honda TRX350TE FourTrax Rancher ES	2000-2003
Honda TRX350TM FourTrax Rancher	2000-2003
Honda TRX400FW Foreman 4x4	1995-2003
Honda TRX450ES	1998-2001
Honda TRX450R	2004-2005
Honda TRX450S	1998-2001
Honda VT750C Shadow Aero	2004-2009
Honda VT750C2 Shadow Spirit	2007-2009
Honda VT750C2F	2007-2008
Honda VT750CA	2004-2009



◀ **cod. HN1017**
Honda Applications
12 Volt Regulator Rectifier Assembly

MAKE / MODEL	YEAR
Honda CB400A Hondamatic	1978
Honda CB400T Hawk	1980-1981
Honda CB400TI Hawk I	1978-1979
Honda CB400TII Hawk II	1978-1979
Honda CB450SC Nighthawk	1982-1986
Honda CB450T Hawk	1982
Honda CH125 Elite	1984
Honda CH150 Elite	1987
Honda CM200T Twinstar	1981-1982
Honda CM400A Hondamatic	1979-1981
Honda CM400C Custom	1981
Honda CM400E	1980-1981
Honda CM400T	1979-1981
Honda CM450A Hondamatic	1982-1983
Honda CM450C Custom	1982
Honda CM450E	1982
Honda CMX450C Rebel	1986-1987
Honda CN250 Helix	2004-2007
Honda FT500 Ascot	1982-1983
Honda GB500	1989-1990



◀ **cod. HN1018**
Honda Applications
12 Volt Regulator Rectifier Assembly

MAKE / MODEL	YEAR
Honda CB400F Super Sport	1975-1977
Honda CB550F Super Sport	1975-1977
Honda CB550K	1975-1978
Honda CB750A Automatic	1976-1977
Honda CB750F Super Sport	1975-1978
Honda CB750K	1975-1978



◀ **cod. HN1020**
Honda Applications
12 Volt Regulator Rectifier Assembly

MAKE / MODEL	YEAR
Honda CB650	1979-1982
Honda CB650C Custom	1980-1981
Honda CB650SC Nighthawk	1982
Honda CBR1000F Hurricane	1987-1988



◀ **cod. HN1021**
Honda Applications
12 Volt Regulator Rectifier Assembly

MAKE / MODEL	YEAR
Honda CB1000C Custom	1983
Honda CB1100F	1983
Honda CB700SC Nighthawk S	1984-1986
Honda CB750C Custom	1980-1982
Honda CB750F Super Sport	1979-1982
Honda CB750K	1979-1982
Honda CB750L	1979
Honda CB750SC Nighthawk	1982-1983
Honda CB900C Custom	1980-1982
Honda CB900F Super Sport	1981-1982
Honda CBX	1979-1982

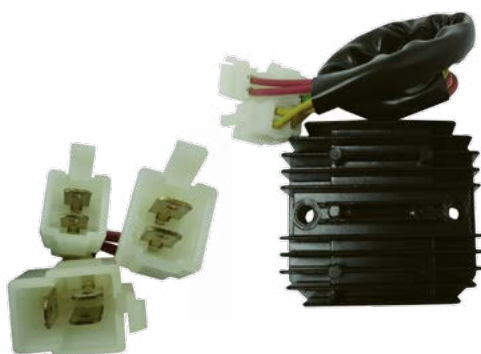

◀ **cod. HN1022**
Honda Applications
12 Volt Regulator Rectifier Assembly

MAKE / MODEL	YEAR
Honda VT1100C Shadow	1987-1996
Honda VT1100C Shadow Spirit	1987-2003
Honda VT1100C2 Shadow Sabre	2000-2003
Honda VT1100C3 Shadow Aero	1988-2002
Honda VT1100T Shadow ACE Tour	1998-2001



◀ **cod. HN1023**
Honda Applications
12 Volt Regulator Rectifier Assembly

MAKE / MODEL	YEAR
Honda MUV700 Big Red	2009-2013
Honda TRX420FA Rancher AT	2009-2013
Honda TRX420FA1 FourTrax Rancher 4x4 Auto DCT	2014
Honda TRX420FA2 FourTrax Rancher 4x4 Auto DCT with EPS	2014
Honda TRX420FE FourTrax Rancher 4X4 ES	2007-2013
Honda TRX420FM FourTrax Rancher 4X4	2007-2013
Honda TRX420FPA Rancher AT 4x4 w/ Power Steering	2009-2014
Honda TRX420FPE Rancher ES 4x4 w/ Power Steering	2009-2013
Honda TRX420FPM Rancher 4x4 w/ Power Steering	2009-2013
Honda TRX420TE FourTrax Rancher ES	2007-2013
Honda TRX420TM FourTrax Rancher	2007-2013



◀ **cod. KM1000**

KTM Applications

12 Volt Regulator Rectifier Assembly

MAKE / MODEL	YEAR
Beta 250 RR (2 Stroke)	2005-2007
Beta 400 RR	2005-2012
Beta 450 RR	2005-2012
Beta 498 RR	2013
KTM 125 EXC	2005-2013
KTM 200 EXC	2005-2014
KTM 200 XC-W	2008-2015
KTM 250 EXC	2005-2015
KTM 250 EXC-F	2007-2011
KTM 250 XC	2009-2015
KTM 250 XC-F	2007-2010
KTM 250 XCF-W	2006-2011
KTM 250 XC-W	2008-2015
KTM 300 EXC	2005-2015
KTM 300 EXC-E	2007-2010
KTM 300 XC	2009-2015
KTM 300 XC-W	2008-2015
KTM 350 EXC-F	2015
KTM 400 EXC	2005-2011
KTM 400 XC-W	2007-2010
KTM 450 EXC	2005-2011
KTM 450 EXC-R	2008
KTM 450 MXC	2005
KTM 450 XC	2006-2007
KTM 450 XC-W	2007-2011
KTM 525 EXC	2005-2007
KTM 525 MXC	2005
KTM 525 XC	2006-2007
KTM 530 EXC	2008-2011
KTM 530 EXC-R	2008
KTM 530 XCR-W	2008
KTM 530 XC-W	2009-2011
KTM 660 SMC	2004-2006



◀ **cod. KW1000N**

Kawasaki Applications

12 Volt Regulator Rectifier Assembly

MAKE / MODEL	YEAR
Kawasaki ZX600 Ninja ZX6-RR	2003-2004
Kawasaki ZX636 Ninja ZX-6R	2003-2004

◀ **cod. KW1002N**

Kawasaki Applications

12 Volt Regulator Rectifier Assembly

MAKE / MODEL	YEAR
Kawasaki ZX900 Ninja ZX-9R	1998-1999





◀ **cod. KW1006N**
Kawasaki Applications
12 Volt Regulator Rectifier Assembly

MAKE / MODEL	YEAR
Kawasaki ER5	1999-2002



◀ **cod. KW1009N**
Kymco Applications
12 Volt Regulator Rectifier Assembly

MAKE / MODEL	YEAR
Kymco Downtown 300i	2011-2015
Kymco People S 250	2007-2009
Kymco Venox 250	2003-2006
Kymco Xciting 500	2005



◀ **cod. KW1010N**
Kawasaki Applications
12 Volt Regulator Rectifier Assembly

MAKE / MODEL	YEAR
Kawasaki ER-6N	2009-2010
Kawasaki EX650 Ninja 650R	2006-2011
Kawasaki KAF620 Mule 3000	2001-2008
Kawasaki KAF620 Mule 3010 4x4	2001-2008
Kawasaki KAF620 Mule 3010 Trans 4x4	2005-2008
Kawasaki KLE650 Versys	2008-2010
Kawasaki KLF400 Bayou 4x4	1993-1999
Kawasaki KVF400 Prairie 4x4	1997-1998
Kawasaki KVF650 Brute Force 4x4i	2007-2008
Kawasaki KVF750 Brute Force 4x4i	2005-2007
Kawasaki VN900B Vulcan 900 Classic	2006-2014
Kawasaki VN900C Vulcan 900 Custom	2007-2014
Kawasaki VN900D Vulcan 900 Classic LT	2006-2014
Kawasaki Z1000	2003-2013
Kawasaki Z750S	2005-2006
Kawasaki ZX1000 Ninja 1000	2011-2013
Kawasaki ZX1000 Ninja 1000 ABS	2012-2013



◀ **cod. KW1019N**
Kawasaki Applications
12 Volt Regulator Rectifier Assembly

MAKE / MODEL	YEAR
Kawasaki ZX600 Ninja ZX-6R	2000-2002
Kawasaki ZZR 600	2005-2008



◀ **cod. KW1021N**
Kawasaki Applications
12 Volt Regulator Rectifier Assembly

MAKE / MODEL	YEAR
Kawasaki EX500 Ninja 500	1994-1996
Kawasaki KLR650	1987-2001
Kawasaki VN700A Vulcan	1985
Kawasaki VN750A Vulcan 750	1986-2001
Kawasaki VN800A Vulcan 800	1999-2002
Kawasaki ZX600 Ninja 600R	1985-1997
Kawasaki ZX600 Ninja ZX-6R	1995-2001

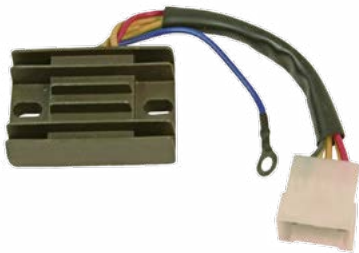

◀ **cod. PL1011N**
Aprilia Motorcycles
12 Volt Regulator Rectifier Assembly

MAKE / MODEL	YEAR
Aprilia Classic 125	1995-1999
Aprilia Leonardo 125	1996-2004
Aprilia Leonardo 150	1996-2004
Aprilia Pegaso 600	1990-1991
Aprilia Pegaso 650	1992-1995
Aprilia RS 125	1996-2009
Aprilia RS 250	1998-2001
Aprilia Scarabeo 125	1999-2003
Aprilia Scarabeo 150	1999-2003
Aprilia SX 125	2008



◀ **cod. S1002GL**
Honda Applications
12 Volt, Shunt-Type, 14.4 Vset

MAKE / MODEL	YEAR
Honda GL1100 Gold Wing	1980-1983
Honda GL1100A Gold Wing Aspencade	1982-1983
Honda GL1100I Gold Wing Interstate	1980-1983
Honda GL1200 Gold Wing	1984
Honda GL1200A Gold Wing Aspencade	1984-1987
Honda GL1200I Gold Wing Interstate	1984-1987
Honda GL1200L Gold Wing Limited	1985
Honda GL1200SEI Gold Wing Aspencade	1986



◀ **cod. S1002GL-135**
Honda Applications
12 Volt, Shunt-Type, 13.5 Vset

MAKE / MODEL	YEAR
Honda GL1100 Gold Wing	1980-1983
Honda GL1100A Gold Wing Aspencade	1982-1983
Honda GL1100I Gold Wing Interstate	1980-1983
Honda GL1200 Gold Wing	1984
Honda GL1200A Gold Wing Aspencade	1984-1987
Honda GL1200I Gold Wing Interstate	1984-1987
Honda GL1200L Gold Wing Limited	1985
Honda GL1200SEI Gold Wing Aspencade	1986



◀ **cod. S1002L**
Suzuki Applications
12 Volt, Shunt-Type, 14.6 Vset

MAKE / MODEL	YEAR
Suzuki GS1100E	1983
Suzuki GS1100ES	1983
Suzuki GS1100G	1983
Suzuki GS1100GK	1983
Suzuki GS1100GL	1983
Suzuki GS1100S Katana	1983
Suzuki GS550E	1983-1986
Suzuki GS650G	1983
Suzuki GS650GL	1983
Suzuki GS650M Katana	1983
Suzuki GS850G	1982
Suzuki GS850GL	1982



◀ **cod. S1002S**
Suzuki Applications
12 Volt, Shunt-Type, 14.6 Vset

MAKE / MODEL	YEAR
Suzuki GR650 Tempter	1983
Suzuki GS1150E	1984-1986
Suzuki GS1150ES	1985
Suzuki GS300L	1983-1985
Suzuki GS450E	1983
Suzuki GS450GA	1983-1985
Suzuki GS450L	1983-1986
Suzuki GS450TX	1983
Suzuki GS750E	1983
Suzuki GS750ES	1983
Suzuki GS750S Katana	1983
Suzuki GS750T	1983

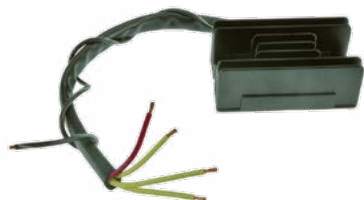

◀ **cod. S1002U**
Kawasaki, Suzuki, Yamaha
12 Volt, Shunt-Type, 14.6 Vset

MAKE / MODEL	YEAR
Suzuki GR650 Tempter	1983
Suzuki GS1100E	1983
Suzuki GS1100ES	1983
Suzuki GS1100G	1983
Suzuki GS1100GK	1983
Suzuki GS1100GL	1983
Suzuki GS1100S Katana	1983
Suzuki GS1150E	1984-1986
Suzuki GS1150ES	1985
Suzuki GS300L	1983-1985
Suzuki GS450E	1983
Suzuki GS450GA	1983-1985
Suzuki GS450L	1983-1986
Suzuki GS450TX	1983

◀ **cod. S1002U** - continued

MAKE / MODEL	YEAR
Suzuki GS550E	1983-1986
Suzuki GS650G	1983
Suzuki GS650GL	1983
Suzuki GS650M Katana	1983
Suzuki GS750E	1983
Suzuki GS750ES	1983
Suzuki GS750S Katana	1983
Suzuki GS750T	1983
Suzuki GS850G	1982
Suzuki GS850GL	1982

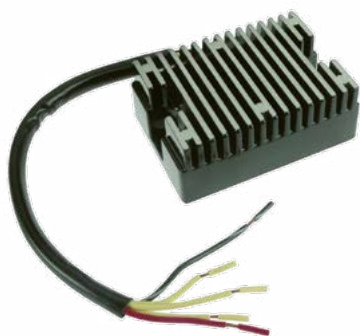

◀ **cod. S1002UH**
Honda, Kawasaki, Suzuki
12 Volt, Shunt-Type, 14.6 Vset

MAKE / MODEL	YEAR
Suzuki GR650 Tempter	1983
Suzuki GS1100E	1983
Suzuki GS1100ES	1983
Suzuki GS1100G	1983
Suzuki GS1100GK	1983
Suzuki GS1100GL	1983
Suzuki GS1100S Katana	1983
Suzuki GS1150E	1984-1986
Suzuki GS1150ES	1985
Suzuki GS300L	1983-1985
Suzuki GS450E	1983
Suzuki GS450GA	1983-1985
Suzuki GS450L	1983-1986
Suzuki GS450TX	1983
Suzuki GS550E	1983-1986
Suzuki GS650G	1983
Suzuki GS650GL	1983
Suzuki GS650M Katana	1983
Suzuki GS750E	1983
Suzuki GS750ES	1983
Suzuki GS750S Katana	1983
Suzuki GS750T	1983
Suzuki GS850G	1982
Suzuki GS850GL	1982



◀ **cod. S1003L**
Honda Applications
12 Volt, Shunt-Type, 14.7 Vset

MAKE / MODEL	YEAR
Honda CB750C Custom	1980-1982
Honda CB750F Super Sport	1979-1982
Honda CB750K	1979-1982
Honda CB750L	1979
Honda CB750SC Nighthawk	1982
Honda CB900C Custom	1980-1982
Honda CB900F Super Sport	1981-1982
Honda CBX	1981-1982



◀ **cod. S1003S**
Honda Applications
12 Volt, Shunt-Type, 14.7 Vset

MAKE / MODEL	YEAR
Honda CB650	1979-1982
Honda CB650C Custom	1980-1981
Honda CB650SC Nighthawk	1982



◀ **cod. S1003U**
Honda Applications
12 Volt, Shunt-Type, 14.7 Vset

MAKE / MODEL	YEAR
Honda CB650	1979-1982
Honda CB650C Custom	1980-1981
Honda CB650SC Nighthawk	1982
Honda CB750C Custom	1980-1982
Honda CB750F Super Sport	1979-1982
Honda CB750K	1979-1982
Honda CB750L	1979
Honda CB750SC Nighthawk	1982
Honda CB900C Custom	1980-1982
Honda CB900F Super Sport	1981-1982
Honda CBX	1981-1982
Yamaha XS650	1975-1981
Yamaha XS650-2 Special II	1979
Yamaha XS650S Special	1978-1983

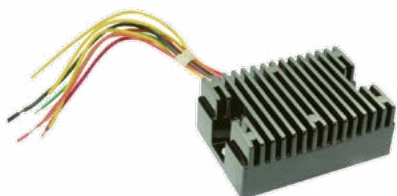

◀ **cod. S1003UH**
Honda, Kawasaki, Suzuki, Yamaha
12 Volt, Shunt-Type, 14.7 Vset

MAKE / MODEL	YEAR
Honda CB650	1979-1982
Honda CB650C Custom	1980-1981
Honda CB650SC Nighthawk	1982
Honda CB750C Custom	1980-1982
Honda CB750F Super Sport	1979-1982
Honda CB750K	1979-1982
Honda CB750L	1979
Honda CB750SC Nighthawk	1982
Honda CB900C Custom	1980-1982
Honda CB900F Super Sport	1981-1982
Honda CBX	1981-1982
Yamaha XS650	1975-1981
Yamaha XS650-2 Special II	1979
Yamaha XS650S Special	1978-1983



◀ **cod. S1004B**
Shindengen Applications
0.5k

MAKE / MODEL	YEAR
Yamaha TDM850	1992-1993
Yamaha XJ600S Seca II	1992-1998



◀ **cod. S1006N**
Suzuki Applications
12 Volt Regulator Rectifier Assembly

MAKE / MODEL	YEAR
Suzuki GSX1300BK B-King	2008
Suzuki GSX-R1000	2007-2008
Suzuki GSX-R600	2006-2007



◀ **cod. S1011N**
Suzuki Motorcycles
12 Volt Regulator Rectifier Assembly

MAKE / MODEL	YEAR
Suzuki GSX1300R Hayabusa	1999-2007
Suzuki GSX-R1000	2001-2004
Suzuki GSX-R600	2001-2005
Suzuki GSX-R750	1998-2005



◀ **cod. S1013N**
Suzuki Motorcycles
12 Volt Regulator Rectifier Assembly

MAKE / MODEL	YEAR
Suzuki DR650SES	1992-1995
Suzuki VS1400GL Intruder	1996-2004
Suzuki VS800GL Intruder	1992-2008



◀ **cod. S1014N**
Suzuki Applications
12 Volt Regulator Rectifier Assembly

MAKE / MODEL	YEAR
Suzuki VS1400GL Intruder	1987-1995



◀ cod. TRR6330

Honda Applications
12 Volt, Shunt-Type, 14.4 Vset

MAKE / MODEL	YEAR
Honda CBR600F F2	1991-1994
Honda CBR600F F3	1995-1998
Honda CBR600F F4	1999-2000
Honda CBR900RR	1992-1999
Honda PC800 Pacific Coast	1989-1998
Honda VTR1000 Super Hawk	1998-2000



◀ cod. YM1000N

Yamaha Applications
12 Volt Regulator Rectifier Assembly

MAKE / MODEL	YEAR
Yamaha FJ-09	2015-2016
Yamaha FJR1300	2006
Yamaha FJR1300A	2007-2015
Yamaha FJR1300A ABS	2006
Yamaha FJR1300AE	2007-2009
Yamaha FJR1300ES	2014-2015
Yamaha FZ-09	2014-2016
Yamaha FZ-1	2006-2015
Yamaha FZ8	2011-2013
Yamaha VMX1700 V-Max	2009-2014
Yamaha XTZ1200 Super Tenere	2012-2016
Yamaha XTZ1200 Super Tenere ES	2014-2016
Yamaha XV1700AS Road Star S	2008-2014
Yamaha XV1700AT Road Star Silverado	2008-2010
Yamaha XV1700ATS Road Star Silverado S	2008-2014
Yamaha XV1900 Roadliner	2006-2007
Yamaha XV1900CT Stratoliner	2006-2009
Yamaha XV1900CT Stratoliner Deluxe	2010-2014
Yamaha XV1900CTS Stratoliner S	2006-2014
Yamaha XV1900M Roadliner Midnight	2006-2009
Yamaha XV1900S Roadliner S	2006-2014
Yamaha XV19C Raider	2008-2015
Yamaha XV19C Raider Bullet Cowl	2015
Yamaha XV19CX Raider	2008-2015
Yamaha XV19SCL Raider SCL	2012-2014
Yamaha XVS1300 V Star 1300	2007-2010
Yamaha XVS1300A V Star 1300 Tourer	2007-2010
Yamaha XVS950 V Star 950	2009-2010
Yamaha XVS950CT V Star 950 Tourer	2009-2010
Yamaha XVS95C Bolt	2014-2016
Yamaha XVS95C Bolt C Spec	2015-2016
Yamaha XVS95C Bolt R Spec	2014-2016
Yamaha YFM550 Grizzly FI 4x4 Auto	2009-2014
Yamaha YFM550 Grizzly FI 4x4 Auto EPS	2009-2014
Yamaha YFM700FG Grizzly 700 4WD	2009-2015
Yamaha YFM700FGH Grizzly 700 4WD Hunter	2009-2014
Yamaha YFM700FGHP Grizzly 700 EPS 4WD Hunter	2009-2011
Yamaha YFM700FGP Grizzly 700 Ducks	2007-2008

◀ **cod. YM1000N** - continued

MAKE / MODEL	YEAR
Yamaha YFM700FGP Grizzly 700 EPS 4WD	2009-2014
Yamaha YFM700FGP Grizzly 700 Hunter	2007-2008
Yamaha YFM700R Grizzly	2006-2008
Yamaha YFM7FGPS Grizzly 700 SE	2008
Yamaha YXC700DF Viking VI	2015
Yamaha YXC700PF Viking VI 700 EPS	2015
Yamaha YXM700DF Viking	2015
Yamaha YXM700PH Viking EPS Hunter	2014-2015
Yamaha YXR700F Rhino 700 FI	2008-2012
Yamaha YZF-R1	2007-2014



◀ **cod. YM1001N**

Yamaha Applications
12 Volt Regulator Rectifier Assembly

MAKE / MODEL	YEAR
Yamaha XP500 TMAX	2009-2015

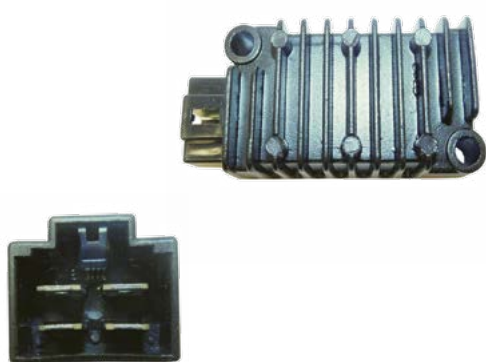

◀ **cod. YM1002N**

Yamaha Motorcycles
12 Volt Regulator Rectifier Assembly

MAKE / MODEL	YEAR
Yamaha FZR400	1988-1990
Yamaha FZR600	1989-1993
Yamaha FZR600R	1990-1994
Yamaha SRX600	1986
Yamaha TW200	1988-2000
Yamaha TZ125	1999-2000
Yamaha TZ250	1999-2001
Yamaha WR200	1992
Yamaha XT225	1992-1995
Yamaha XT600	1990-1995
Yamaha XV250 Route 66	1988-1990



◀ **cod. YM1003N**

Yamaha Applications
12 Volt Regulator Rectifier Assembly

MAKE / MODEL	YEAR
Yamaha FZR600R	1995-1999
Yamaha YZF600R	1995-2007
Yamaha YZF-R1	1998-2001
Yamaha YZF-R6	1999-2002



◀ **cod. YM1005N**
Yamaha Applications
12 Volt Regulator Rectifier Assembly

MAKE / MODEL	YEAR
Yamaha VMX1200 V-Max	1985-1995
Yamaha XV1100 Virago	1986-1995
Yamaha XV535 Virago	1987-1995
Yamaha XV700 Virago	1984-1987
Yamaha XV750 Virago	1989-1995



◀ **cod. YM1006N**
Kawasaki Applications
12 Volt Regulator Rectifier Assembly

MAKE / MODEL	YEAR
Kawasaki EX250F Ninja 250R	2008-2012
Kawasaki KEF300 Lakota Sport	2001-2003
Kawasaki KEF300 Lakota Utility	1995-2000
Kawasaki KLF300 Bayou 2x4	1992-2001
Kawasaki KLF300 Bayou 4x4	1989-2002
Kawasaki KLR650	2008-2014
Kawasaki KLX250S	2009-2014
Kawasaki KLX250SF	2009-2010
Kawasaki VN1500A Vulcan 1500	1996-1999
Kawasaki VN1500A Vulcan 88	1992-1995
Kawasaki VN1500C Vulcan L	1996-1997
Kawasaki VN750A Vulcan 750	1994-2006
Kawasaki ZL600 Eliminator	1996-1997
Kawasaki ZR-7	2000
Kawasaki ZR-7S	2001-2005
Kawasaki ZX600 Ninja 600R	1994-1997
Kawasaki ZX600 Ninja ZX-6	1993-2001
Kawasaki ZX600 Ninja ZX-6R	1995-1997
Kawasaki ZZR 600	2003-2004



◀ **cod. YM1009N**
Yamaha Applications
12 Volt Regulator Rectifier Assembly

MAKE / MODEL	YEAR
Yamaha YW125 Zuma 125	2009-2014



◀ cod. **YM1026N**

Yamaha Motorcycles
12 Volt Regulator Rectifier Assembly

MAKE / MODEL	YEAR
Yamaha FJ600	1984-1985
Yamaha FZ600	1986-1988
Yamaha XJ550 Maxim	1981-1983
Yamaha XJ550R Seca	1981-1983
Yamaha XJ650 Maxim	1980-1983
Yamaha XJ650L Turbo Seca	1981-1983
Yamaha XJ650R Seca	1982
Yamaha XJ700 Maxim	1985-1986
Yamaha XJ700X Maxim X	1985-1986
Yamaha XJ750M Mid-Max	1983
Yamaha XJ750R Seca	1981-1983
Yamaha XJ900 Seca	1983
Yamaha XS400	1982-1983
Yamaha XS400R Seca	1982-1983
Yamaha XS650	1978-1981
Yamaha XS650S Special	1978-1982
Yamaha YX600 Radian	1986-1988



◀ cod. **YM1034N**

Yamaha Applications
12 Volt Regulator Rectifier Assembly

MAKE / MODEL	YEAR
Yamaha XV1600A Road Star	2003
Yamaha XV1600AS Road Star Midnight	2001-2003
Yamaha XVS1100 V Star 1100 Custom	2000-2001
Yamaha XVS1100A V Star 1100 Classic	2000-2002
Yamaha XVS650 V Star Custom	1998-2000
Yamaha XVS650A V Star Classic	1999-2000
Yamaha YFM660F Grizzly 4x4	2001-2008
Yamaha YFM700R Raptor	2006-2014
Yamaha YFZ450R	2009-2014
Yamaha YFZ450R SE	2009-2015
Yamaha YFZ450X	2010-2011
Yamaha YXR45F Rhino 450	2006-2009
Yamaha YXR66F Rhino 660	2004-2007



◀ **cod. RL00001**
Ruota libera motore scooter 50 cc Minarelli/Yamaha

RIFERIMENTO ORIGINALE

Aprilia	AP8206147
Benelli	R16140181A0

Malaguti	74012500
Yamaha	3VL155700000



◀ **cod. RL00002**
Ruota libera scooter Minarelli/Yamaha 125/150 cc

RIFERIMENTO ORIGINALE

Yamaha	5NSE55700000
--------	--------------

Mbk	5NSE55700000
-----	--------------

APPLICABILITÀ

BENELLI VELVET 125 4T 99-01, VELVET 150 4T 99-01
ITALJET JUPITER 125 4T 01-02, MILLENIUM 125 4T 00-02, JUPITER 150 4T 01-02, MILLENIUM 150 4T 00-02
MALAGUTI MADISON 125 4T 99-01, MADISON R RESTYLING 125 4T 02-02, MADISON R RESTYLING EU2 125 4T 03-04, PHANTOM MAX 125 4T 03-03, MADISON T 150 4T 99-01

MBK DOODO 125 4T 00-00, FLAME T 125 4T 95-99, SKYLINER 125 4T 98-02, THUNDER 125 4T 01-02, DOODO 150 4T 01-02, SKYLINER 150 4T 00-02, THUNDER 150 4T 01-02
YAMAHA MAJESTY 125 4T 98-00, MAJESTY (SNR1) 125 4T 01-01, MAJESTY (SNR8) 125 4T 02-02, MAXSTER 125 4T 01-02, TEO'S 125 4T 00-00, MAJESTY 150 4T 00-00, MAJESTY (SNS1) 150 4T 01-01, MAJESTY (SNS6) 150 4T 02-02, MAXSTER 150 4T 01-02, TEO'S 150 4T 01-02



◀ **cod. RL00003**
Ruota libera Honda SH-Pantheon 125/150 cc 4T

RIFERIMENTO ORIGINALE

Honda	28125KGF911
-------	-------------

APPLICABILITÀ

HONDA @ [NES] 125 4T 00-06, DYLAN [SES] 125 4T 02-04, PANTHEON IE [FES] 125 4T-2V 03-05, PS I [PES] 125 4T 06-10, SH 125 4T-2V 01-04, SH IE SCOOPIY 125 4T-2V 05-12, SILVER WING [FES] 125 4T-2V 07-12, @ [NES] 150 4T 00-06, DYLAN [SES] 150 4T 02-04, PANTHEON IE [FES] 150 4T-2V 03-05, PS I [PES] 150 4T 06-10, SH 150 4T-2V 01-04, SH IE SCOOPIY 150 4T 05-12, SILVER WING [FES] 150 4T-2V 07-12



◀ **cod. RL00004**
Ruota libera Honda Foresight 250 cc 4T

RIFERIMENTO ORIGINALE

Honda	28120KM1013
-------	-------------

APPLICABILITÀ

HONDA CN SPAZIO/HELIX 250 4T 86-99, FORESIGHT [FES] 250 4T 98-99, FORESIGHT [FES] D.D. 250 4T 00-05, FORZA [NSS] 250 4T-2V 02-07, JAZZ ES REFLEX [NSS] 250 4T-2V 01-04, JAZZ REFLEX [NSS] 250 4T-2V 01-01



◀ **cod. RL00005**
Ruota libera Aprilia Scarabeo 150/200 cc 4T

RIFERIMENTO ORIGINALE

Aprilia	AP0259495
---------	-----------

APPLICABILITÀ

APRILIA LEONARDO 125 4T 96-02, LEONARDO ST 125 4T 03-04, SCARABEO 125 4T 99-03, LEONARDO 150 4T 96-02, SCARABEO 150 4T 99-03, SCARABEO 200 4T 01-03
BMW C1 125 4T 00-03, C1 200 4T 02-03

HONDA @ [NES] 125 4T 00-06, DYLAN [SES] 125 4T 02-04, PANTHEON IE [FES] 125 4T-2V 03-05, PS I [PES] 125 4T 06-10, SH 125 4T-2V 01-04, SH IE SCOOPIY 125 4T-2V 05-12, SILVER WING [FES] 125 4T-2V 07-12, @ [NES] 150 4T 00-06, DYLAN [SES] 150 4T 02-04, PANTHEON IE [FES] 150 4T-2V 03-05, PS I [PES] 150 4T 06-10, SH 150 4T-2V 01-04, SH IE SCOOPIY 150 4T 05-12, SILVER WING [FES] 150 4T-2V 07-12



◀ cod. **RL00013**
Ingranaggio ruota libera Aprilia Scarabeo
150/200 cc 4T

RIFERIMENTO ORIGINALE

Aprilia	AP0259480
---------	-----------

APPLICABILITÀ

APRILIA LEONARDO 125 4T 96-02, LEONARDO ST 125 4T 03-04, SCARABEO 125 4T 99-03, LEONARDO 150 4T 96-02, SCARABEO 150 4T 99-03, SCARABEO 200 4T 01-03

BMW C1 125 4T 00-03, C1 200 4T 02-03



◀ cod. **RL00014**
Flangia ruota libera Aprilia Scarabeo 150/200 cc 4T

RIFERIMENTO ORIGINALE

Aprilia	AP0635150
---------	-----------

APPLICABILITÀ

APRILIA LEONARDO 125 4T 96-02, LEONARDO ST 125 4T 03-04, SCARABEO 125 4T 99-03, LEONARDO 150 4T 96-02, SCARABEO 150 4T 99-03, SCARABEO 200 4T 01-03

BMW C1 125 4T 00-03, C1 200 4T 02-03



◀ cod. **RL00006**
Ruota libera Kymco Grand Dink 150 cc

RIFERIMENTO ORIGINALE

Kymco	00128934
-------	----------

APPLICABILITÀ

KYMCO B&W 125 4T 00-00, B&W EU2 125 4T 03-04, DINK 125 4T 97-98, DINK CLASSIC 125 4T 02-02, DINK CLASSIC EU2 125 4T 03-03, DINK EU3 125 4T 06-07, DINK LX 125 4T 98-00, DOWNTOWN E4 125 4T 16-16, DOWNTOWN I 125 4T 09-16, GRAND DINK 125 4T 01-02, GRAND DINK EU2 125 4T 03-04, K-XCT I 125 4T 12-14, PEOPLE GTI 125 4T 10-10, PEOPLE GTI 125 4T 14-14, X-TOWN CBS 125 4T 4V 16-16, B&W 150 4T 00-00, B&W EU2 150 4T 03-04, DINK 150 4T 97-98, DINK CLASSIC 150 4T 02-02, DINK CLASSIC EU2 150 4T 03-03, DINK LX 150 4T 98-00, GRAND DINK 150 4T 01-02, GRAND DINK EU2 150 4T 03-04



◀ cod. **RL00007**
Ingranaggio ruota libera Kymco Grand Dink 150 cc

RIFERIMENTO ORIGINALE

Kymco	00128929
-------	----------

APPLICABILITÀ

KYMCO B&W 125 4T 00-00, DINK 125 4T 97-98, DINK CLASSIC 125 4T 02-02, DINK CLASSIC EU2 125 4T 03-03, DINK LX 125 4T 98-00, GRAND DINK 125 4T 01-02, B&W 150 4T 00-00, DINK 150 4T 97-98, DINK CLASSIC 150 4T 02-02, DINK CLASSIC EU2 150 4T 03-03, DINK LX 150 4T 98-00, GRAND DINK 150 4T 01-02



◀ cod. **RL00008**
Ruota libera Kymco Grand Dink 250 cc

RIFERIMENTO ORIGINALE

Kymco	00128935
-------	----------

APPLICABILITÀ

KYMCO DINK CLASSIC 200 4T 04-04, DINK IE EU3 200 4T 06-07, B&W 250 4T 00-00, B&W EU2 250 4T 03-03, GRAND DINK 250 4T 01-02, GRAND DINK EU2 250 4T 03-04, KXR 250 4T 03-04, MXU 250 4T 05-05, PEOPLE LC 250 4T 03-04, YUP 250 4T 03-03, MAXXER 300 4T 05-06, MXU 300 4T 05-06



◀ **cod. RL00009**
Ingranaggio ruota libera Kymco Grand Dink 250 cc

RIFERIMENTO ORIGINALE

Kymco	00128933
-------	----------

APPLICABILITÀ

KYMCO B&W 250 4T 00-00, B&W EU2 250 4T 03-03, GRAND DINK 250 4T 01-02, GRAND DINK EU2 250 4T 03-04, KXR 250 4T 03-04, MXU 250 4T 05-05, PEOPLE LC 250 4T 03-04, YUP 250 4T 03-03, MAXXER 300 4T 05-06, MXU 300 4T 05-06



◀ **cod. RL00010**
Ruota libera per scooter Minarelli/Yamaha 250 cc

RIFERIMENTO ORIGINALE

Yamaha	4HC155900200
Mbk	4HC155900200
Benelli	R19040171A0

Malaguti	94000600
Aprilia	AP8122626

APPLICABILITÀ

APRILIA LEONARDO 250 4T 99-04, LEONARDO ST 250 4T 01-01, LEONARDO 300 4T 02-04
BENELLI VELVET 250 4T 99-03
ITALJET JUPITER 250 4T 00-02
MALAGUTI MADISON S 250 4T 99-01, PASSWORD 250 4T 05-06, PASSWORD EU3 250 4T 07-08
MBK SKYLINER 250 4T 00-03, SKYLINER ABS 250 4T 03-03, KILIBRE 300 4T 03-06
YAMAHA MAJESTY 250 4T 96-03, MAJESTY ABS 250 4T 03-03, MAJESTY DX 250 4T 98-99, X-CITY 250 4T 07-15, X-MAX 250 4T 05-16, X-MAX ABS 250 4T 14-15, VERSITY 300 4T 03-06



◀ **cod. RL00011**
Ingranaggio ruota libera Minarelli/Yamaha 250 cc

RIFERIMENTO ORIGINALE

Yamaha	1COE55170000
Benelli	R19040161A0

Malaguti	74018700
Aprilia	AP8122499

APPLICABILITÀ

APRILIA LEONARDO 250 4T 99-04, LEONARDO ST 250 4T 01-01, LEONARDO 300 4T 02-04
BENELLI VELVET 250 4T 99-03
ITALJET JUPITER 250 4T 00-02
MALAGUTI MADISON S 250 4T 99-01, PASSWORD 250 4T 05-06, PASSWORD EU3 250 4T 07-08
MBK SKYLINER 250 4T 00-03, SKYLINER ABS 250 4T 03-03, KILIBRE 300 4T 03-06
YAMAHA MAJESTY 250 4T 96-03, MAJESTY ABS 250 4T 03-03, MAJESTY DX 250 4T 98-99, X-CITY 250 4T 07-15, X-MAX 250 4T 05-16, X-MAX ABS 250 4T 14-15, VERSITY 300 4T 03-06



◀ **cod. RL00012**
Ruota libera con ingranaggio Suzuki Burgman 400 cc

RIFERIMENTO ORIGINALE

Suzuki	12600-15824-000
--------	-----------------

APPLICABILITÀ

SUZUKI AN BURGMAN K3/K6 400 4T 03-06, AN BURGMAN X/K2 400 4T 99-02



◀ **cod. RL00015**
Ruota libera Yamaha T-max 500 cc

RIFERIMENTO ORIGINALE

Yamaha	4NK155900000
--------	--------------

APPLICABILITÀ

YAMAHA T-MAX 4BS 500 4T 09-11, T-MAX 4BS ABS 500 4T 08-11, T-MAX 5GJ 500 4T 01-03, T-MAX 5VU 500 4T 04-08, T-MAX 5VU ABS 500 4T 05-07, T-MAX 5VU BLACK MAX 500 4T 06-06, T-MAX 5VU BLACK MAX - NIGHT MAX 500 4T 07-07, T-MAX 59C 530 4T 12-16, T-MAX 59C ABS 530 4T 12-16, T-MAX 59C SP 530 4T 15-15, T-MAX 59C SP ABS 530 4T 15-16, SCR950 950 4T 17-17, XV950 950 4T 14-14, XV950 RACER 950 4T 15-16, XV950CU 950 4T 14-16, XV950R 950 4T 14-17, XT1200Z SUPER TENERE 1200 4T 10-15, XT1200Z SUPER TENERE 1200 4T 17-17, XT1200ZE SUPER TENERE 1200 4T 14-15, XT1200ZE SUPER TENERE 1200 4T 17-17, FJR1300 1300 4T 01-04, FJR1300A 1300 4T 16-18, FJR1300A ABS 1300 4T 03-08, FJR1300A ABS 1300 4T 10-11, FJR1300A ABS 1300 4T 13-15, FJR1300AE 1300 4T 14-18, FJR1300AS 1300 4T 06-08, FJR1300AS 1300 4T 13-18, XVS1300A MIDNIGHT STAR 1300 4T 07-08, XVS1300A MIDNIGHT STAR 1300 4T 11-16, XVS1300CU CUSTOM 1300 4T 14-16, XVZ ROYAL STAR 1300 4T 96-00, XVZTF ROYAL STAR VENTURE 1300 4T 00-00, V-MAX 1700 4T 09-16



◀ **cod. RL00016**
Ingranaggio ruota libera Yamaha T-max 500 cc

RIFERIMENTO ORIGINALE

Yamaha	5GJ155170000
--------	--------------

APPLICABILITÀ

YAMAHA T-MAX 4BS 500 4T 09-11, T-MAX 4BS ABS 500 4T 08-11, T-MAX 5GJ 500 4T 01-03, T-MAX 5VU 500 4T 04-08, T-MAX 5VU ABS 500 4T 05-07, T-MAX 5VU BLACK MAX 500 4T 06-06, T-MAX 5VU BLACK MAX - NIGHT MAX 500 4T 07-07, T-MAX 59C 530 4T 12-16, T-MAX 59C ABS 530 4T 12-16, T-MAX 59C SP 530 4T 15-15, T-MAX 59C SP ABS 530 4T 15-16, XP530-A T-MAX SX 530 4T 17-19, XP530D-A T-MAX DX 530 4T 17-19, XP530E-A T-MAX 530 4T 17-18



◀ **cod. RL00017**
Ruota libera con Ingranaggio Suzuki Burgman 125/150 cc

RIFERIMENTO ORIGINALE

Suzuki	12600-21822-000
--------	-----------------

APPLICABILITÀ

SUZUKI EPICURO 125 4T 99-01, UH BURGMAN K2/K6 125 4T 02-06, EPICURO 150 4T 99-01, UH BURGMAN K2/K6 150 4T 02-06



◀ **cod. RL00018**
Ruota libera con Ingranaggio Suzuki Burgman 250 cc

RIFERIMENTO ORIGINALE

Suzuki	12600-14810-000
--------	-----------------

APPLICABILITÀ

SUZUKI AN BURGMAN K1/K2 250 4T 01-02, AN BURGMAN K3/K6 250 4T 03-06, AN BURGMAN W/X/Y 250 4T 98-00



◀ **cod. RL00019**
Ruota libera Yamaha Majesty 400 cc

RIFERIMENTO ORIGINALE

Yamaha	5RU155900000
--------	--------------

APPLICABILITÀ

YAMAHA MAJESTY 400 4T 04-11, MAJESTY ABS 400 4T 07-11, X-MAX 400 4T-4V 13-16, X-MAX ABS 400 4T-4V 14-17, X-MAX IRONMAX ABS 400 4T-4V 16-16, X-MAX MOMODESIGN 400 4T-4V 14-14, X-MAX MOMODESIGN ABS 400 4T-4V 14-14, X-MAX RA 400 4T-4V 18-18



◀ **cod. RL00020**
Ingranaggio ruota libera Yamaha Majesty 400 cc

RIFERIMENTO ORIGINALE

Yamaha	5RU155170000
--------	--------------

APPLICABILITÀ

YAMAHA MAJESTY 400 4T 04-11, MAJESTY ABS 400 4T 07-11, X-MAX 400 4T-4V 13-16, X-MAX ABS 400 4T-4V 14-17, X-MAX IRONMAX ABS 400 4T-4V 16-16, X-MAX MOMODESIGN 400 4T-4V 14-14, X-MAX MOMODESIGN ABS 400 4T-4V 14-14, X-MAX RA 400 4T-4V 18-18



◀ **cod. RL00021**
Ruota libera Piaggio 500 cc

RIFERIMENTO ORIGINALE

Piaggio	8494905
Aprilia	8494905
Gilera	8494905

Derbi	8494905
Malaguti	44003600
Peugeot	759737

APPLICABILITÀ

APRILIA ATLANTIC ARRECIFE 200 4T 03-05, ATLANTIC ARRECIFE 250 4T 03-05, ATLANTIC 300 4T 10-11, SCARABEO LIGHT 300 4T 09-10, SPORT CITY CUBE 300 4T 08-10, SPORT CITY STREET 300 4T-4V 12-12, SR MAX 300 4T 11-14, ATLANTIC ARRECIFE 400 4T 05-08, ATLANTIC SPRINT 400 4T 05-08, SCARABEO LIGHT 400 4T 06-08, ATLANTIC 500 4T 01-04, ATLANTIC ARRECIFE 500 4T 05-08, ATLANTIC SPRINT 500 4T 05-08, SCARABEO 500 4T 03-06, SCARABEO LIGHT 500 4T 06-08

DERBI GP1 250 4T 06-07, RAMBLA 300 4T 10-11

GILERA NEXUS EU3 300 4T 08-11, FUOCO IE EU3 500 4T 07-13, NEXUS 500 4T 03-05, NEXUS EU3 500 4T 06-11, NEXUS SP EU3 500 4T 06-07

MALAGUTI MADISON RS 250 4T 04-04, PHANTOM MAX 250 4T 04-04, SPIDER MAX GT 500 4T 04-05, SPIDER MAX GT EU3 500 4T 06-06, SPIDER MAX RS 500 4T 08-08

PEUGEOT GEOPOLIS IE EU3 400 4T-4V 90-02, SATELIS EU3 400 4T 07-12, GEOPOLIS IE EU3 500 4T-4V 90-02, SATELIS EU3 500 4T 90-02

PIAGGIO BEVERLY RST 250 4T 04-05, VESPA GTS ABS 250 4T 05-12, X9 EVOLUTION 250 4T 04-04, X9 EVOLUTION 250 4T 06-06, BEVERLY RST 4T 4V IE EU3 300 4T 10-16, BEVERLY TOURER EU3 300 4T 09-10, CARNABY CRUISER 300 4T 09-12, MP3 4T 4V IE LT IBRIDO 300 4T 10-11, MP3 IE LT 300 4T 10-11, MP3 IE LT TOURING 300 4T 11-13, MP3 IE LT/SPORT 300 4T 11-14, MP3 IE MIC 300 4T 10-11, MP3 IE TOURING 300 4T 11-12, VESPA GTS IE TOURING 300 4T 11-12, VESPA GTS SUPER 300 4T 08-16, VESPA GTS SUPER SPORT 300 4T 10-13, VESPA GTV 4T 4V IE 300 4T 10-13, VESPA GTV VIA MONTENAPOLEONE 300 4T 10-10, X7 EVO IE EU3 300 4T 09-10, BEVERLY 4T 4V IE EU3 350 4T 11-14, BEVERLY 4T ST IE ABS 350 4T 16-16, X10 4T 4V IE EURO3 350 4T 12-15, BEVERLY EU3 400 4T 06-07, BEVERLY TOURER EU3 400 4T 08-10, MP3 400 4T 07-08, MP3 IE LT TOURING 400 4T 11-11, MP3 IE LT/SPORT 400 4T 08-10, MP3 MIC 400 4T 08-10, MP3 RL TOURING 400 4T 11-11, X-EVO 400 4T 07-11, X8 EU3 400 4T 06-08, BEVERLY 500 4T 02-06, BEVERLY CRUISER 500 4T 07-12, BEVERLY IE EU3 500 4T 06-08, MP3 LT SPORT/BUSINESS 500 4T 11-13, MP3 RL SPORT-BUSINESS 500 4T 11-12, X9 500 4T 01-02, X9 EVOLUTION 500 4T 03-07



◀ cod. **RL00023**
Ingranaggio ruota libera Piaggio 500 cc

RIFERIMENTO ORIGINALE

Piaggio	82737R
Malaguti	44001900
Peugeot	758789

Aprilia	82737R
Gilera	82737R
Derbi	82737R

APPLICABILITÀ

APRILIA SR MAX 125 4T 11-14, ATLANTIC 250 4T 03-05, ATLANTIC EU3 250 4T 06-08, SCARABEO 250 4T 04-06, SCARABEO LIGHT 250 4T 06-08, SPORT CITY CUBE 250 4T 08-12, SPORT CITY EU3 250 4T 06-08, ATLANTIC 300 4T 10-11, SCARABEO LIGHT 300 4T 09-10, SPORT CITY CUBE 300 4T 08-10, SPORT CITY STREET 300 4T-4V 12-12, SR MAX 300 4T 11-14, ATLANTIC ARRECIFE 400 4T 05-08, ATLANTIC SPRINT 400 4T 05-08, SCARABEO LIGHT 400 4T 06-08, ATLANTIC 500 4T 01-04, ATLANTIC ARRECIFE 500 4T 05-08, ATLANTIC SPRINT 500 4T 05-08, SCARABEO 500 4T 03-06, SCARABEO LIGHT 500 4T 06-08

DERBI GP1 250 4T 06-07, GP1 LOW SEAT EU3 250 4T 07-08, RAMBLA EU3 2VER 250 4T 08-08, RAMBLA 300 4T 10-11

GILERA NEXUS IE EU3 125 4T 08-10, NEXUS EU3 250 4T 06-07, NEXUS SP EU3 250 4T 06-07, NEXUS EU3 300 4T 08-11, FUOCO IE EU3 500 4T 07-13, NEXUS 500 4T 03-05, NEXUS EU3 500 4T 06-11, NEXUS SP EU3 500 4T 06-07

MALAGUTI MADISON 3 250 4T 06-09, MADISON RS 250 4T 04-04, PHANTOM MAX 250 4T 04-04, SPIDER MAX GT 500 4T 04-05, SPIDER MAX GT EU3 500 4T 06-06, SPIDER MAX RS 500 4T 08-08

PEUGEOT GEOPOLIS IE EU3 400 4T-4V 90-02, SATELIS EU3 400 4T 07-12, GEOPOLIS IE EU3 500 4T-4V 90-02, SATELIS EU3 500 4T 90-02

PIAGGIO MP3 IBRIDO 125 4T 09-10, MP3 IE 125 4T 08-09, MP3 IE TOURING 125 4T 11-12, MP3 YOURBAN ERL 125 4T 11-13, VESPA GTS 4T IE SUPER 125 4T 09-16, X7 EVO IE EU3 125 4T 09-10, BEVERLY 250 4T 05-07, BEVERLY CRUISER 250 4T 07-09, BEVERLY EURO 3 MIC 250 4T 07-07, BEVERLY IE EU3 250 4T 06-08, BEVERLY RST 250 4T 04-05, BEVERLY SPORT 250 4T 06-08, BEVERLY TOURER EU3 250 4T 07-09, CARNABY 250 4T 08-09, MP3 250 4T 06-08, MP3 LT 250 4T 08-09, MP3 MIC 250 4T 08-09, VESPA GT 60 EU3 250 4T 06-07, VESPA GTS 250 4T 05-16, VESPA GTS ABS 250 4T 05-12, VESPA GTV 250 4T 06-09, VESPA GTV 4T NAVY EU3 250 4T 07-07, X-EVO 250 4T 07-16, X7 EU3 250 4T 08-08, X8 EU3 250 4T 05-08, X9 EVOLUTION 250 4T 04-04, X9 EVOLUTION 250 4T 06-06, BEVERLY RST 4T 4V IE EU3 300 4T 10-16, BEVERLY TOURER EU3 300 4T 09-10, MP3 4T 4V IE LT IBRIDO 300 4T 10-11, MP3 IE LT 300 4T 10-11, MP3 IE LT TOURING 300 4T 11-13, MP3 IE LT/SPORT 300 4T 11-14, MP3 IE MIC 300 4T 10-11, MP3 IE TOURING 300 4T 11-12, MP3 YOURBAN ERL 300 4T 11-15, MP3 YOURBAN LT ERL 300 4T 11-12, VESPA GTS IE TOURING 300 4T 11-12, VESPA GTS SUPER 300 4T 08-16, VESPA GTS SUPER SPORT 300 4T 10-13, VESPA GTV 4T 4V IE 300 4T 10-13, VESPA GTV VIA MONTENAPOLIONE 300 4T 10-10, X7 EVO IE EU3 300 4T 09-10, BEVERLY 4T 4V IE EU3 350 4T 11-14, BEVERLY 4T ST IE ABS 350 4T 16-16, X10 4T 4V IE EURO3 350 4T 12-15, BEVERLY EU3 400 4T 06-07, BEVERLY TOURER EU3 400 4T 08-10, MP3 400 4T 07-08, MP3 IE LT TOURING 400 4T 11-11, MP3 IE LT/SPORT 400 4T 08-10, MP3 MIC 400 4T 08-10, MP3 RL TOURING 400 4T 11-11, X-EVO 400 4T 07-11, X8 EU3 400 4T 06-08, BEVERLY 500 4T 02-06, BEVERLY CRUISER 500 4T 07-12, BEVERLY IE EU3 500 4T 06-08, MP3 LT SPORT/BUSINESS 500 4T 11-13, MP3 RL SPORT-BUSINESS 500 4T 11-12, X9 500 4T 01-02, X9 EVOLUTION 500 4T 03-07, X9 EVOLUTION ABS 500 4T 06-07



◀ cod. **RL00024**
Ingranaggio ruota libera Kymco Agility 125 cc

RIFERIMENTO ORIGINALE

Kymco	001228728
-------	-----------

Malaguti	54001200
----------	----------

APPLICABILITÀ

KYMCO AGILITY 125 4T 06-06, AGILITY EU3 125 4T 06-08, HEROISM 125 4T 95-97, MOVIE EU3 125 4T 06-07, PEOPLE 125 4T 99-00, PEOPLE EU3 125 4T 07-08, PEOPLE S 125 4T 05-05, SUPER 8 125 4T 08-09, VIVIO 125 4T 00-00, HEROISM 150 4T 95-97, MOVIE EU3 150 4T 06-07, PEOPLE 150 4T 99-00, VIVIO 150 4T 00-00, PEOPLE S 200 4T 05-05

MALAGUTI CIAK MASTER 125 4T 04-04, CIAK MASTER 150 4T 04-04, CIAK MASTER EURO 2 200 4T 06-06



◀ cod. **RL00025**
Ruota libera Kymco Agility 125 cc

RIFERIMENTO ORIGINALE

Kymco	001228742
-------	-----------

Malaguti	54001900
----------	----------

APPLICABILITÀ

KYMCO AGILITY 125 4T 06-06, AGILITY EU3 125 4T 06-08, MOVIE EU3 125 4T 06-07, PEOPLE 125 4T 99-00, PEOPLE EU3 125 4T 07-08, PEOPLE S 125 4T 05-05, SUPER 8 125 4T 08-09, VIVIO 125 4T 00-00, MOVIE EU3 150 4T 06-07, PEOPLE 150 4T 99-00, VIVIO 150 4T 00-00, PEOPLE S 200 4T 05-05

MALAGUTI CIAK MASTER 125 4T 04-04, CIAK MASTER 150 4T 04-04, CIAK MASTER EURO 2 200 4T 06-06





◀ **cod. RL00026**
Ingranaggio ruota libera Kymco Xciting 500 cc

RIFERIMENTO ORIGINALE

Kymco	00128059
-------	----------

APPLICABILITÀ

KYMCO X CITING 500 4T 05-05, X CITING I 500 4T 06-08, X CITING I R 500 4T 07-08, X CITING R 500 4T 09-09



◀ **cod. RL00027**
Ruota libera Kymco Xciting 500 cc

RIFERIMENTO ORIGINALE

Kymco	00128060
-------	----------

APPLICABILITÀ

KYMCO X CITING 500 4T 05-05, X CITING I 500 4T 06-08, X CITING I R 500 4T 07-08, X CITING R 500 4T 09-09



◀ **cod. RL00028**
Ruota libera Kymco Xciting 250 cc

RIFERIMENTO ORIGINALE

Kymco	00126013
-------	----------

APPLICABILITÀ

HONDA @ [NES] 125 4T 00-06, DYLAN [SES] 125 4T 02-04, PANTHEON IE [FES] 125 4T-2V 03-05, PS I [PES] 125 4T 06-10, SH 125 4T-2V 01-04, SH IE SCOOPY 125 4T-2V 05-12, SILVER WING [FES] 125 4T-2V 07-12, @ [NES] 150 4T 00-06, DYLAN [SES] 150 4T 02-04, PANTHEON IE [FES] 150 4T-2V 03-05, PS I [PES] 150 4T 06-10, SH 150 4T-2V 01-04, SH IE SCOOPY 150 4T 05-12, SILVER WING [FES] 150 4T-2V 07-12

KYMCO G-DINK 125 4T 12-12, DINK IE EU3 200 4T 06-07, DOWNTOWN I 200 4T 10-10, PEOPLE GTI 200 4T 10-10, PEOPLE GTI 200 4T 14-14, PEOPLE S 250 4T 06-06, PEOPLE S I 250 4T 07-07, X CITING 250 4T 05-05, X CITING I 250 4T 06-07, DOWNTOWN ABS 300 4T 10-10, DOWNTOWN I 300 4T 09-09, DOWNTOWN I 300 4T 11-11, DOWNTOWN I ABS 300 4T 11-16, G-DINK 300 4T-2V 12-12, K-XCT I 300 4T 12-12, K-XCT I ABS 300 4T 14-14, MAXXER 300 4T 05-06, MXU 300 4T 05-06, MXU R 300 4T 10-10, PEOPLE GTI 300 4T 10-11, PEOPLE GTI 300 4T 14-14, PEOPLE GTI ABS 300 4T 12-12, PEOPLE GTI ABS 300 4T 14-14, PEOPLE GTI ABS E4 300 4T 16-16, PEOPLE S I 300 4T 08-08, X CITING I 300 4T 08-08, X CITING I R 300 4T 08-09, DOWNTOWN ABS E4 350 4T 16-16, DOWNTOWN I ABS 350 4T 15-15



◀ **cod. RL00031**
Ingranaggio ruota libera Kymco Xciting 250 cc

RIFERIMENTO ORIGINALE

Kymco	00126012
-------	----------

APPLICABILITÀ

KYMCO PEOPLE S 250 4T 06-06, PEOPLE S I 250 4T 07-07, X CITING 250 4T 05-05, X CITING I 250 4T 06-07, MXU R 300 4T 10-10, PEOPLE S I 300 4T 08-08, X CITING I 300 4T 08-08, X CITING I R 300 4T 08-09



◀ **cod. RL00029**
Ingranaggio ruota libera Honda SH 300 cc

RIFERIMENTO ORIGINALE

Honda	28110KTW900
-------	-------------

APPLICABILITÀ

HONDA FORZA [NSS A] 250 4T-4V 08-11, FORZA [NSS S] 250 4T-4V 08-11, SH IE SCOOPY 300 4T-4V 07-19



◀ cod. **RL00030**
Ruota libera Honda SH 300 cc

RIFERIMENTO ORIGINALE

Honda	28125HN5671
-------	-------------

APPLICABILITÀ

HONDA FORZA EX [NSS] 250 4T-2V 05-07, FORZA X [NSS] 250 4T-2V 05-07, FORZA [NSS A] 250 4T-4V 08-11, FORZA [NSS S] 250 4T-4V 08-11, SH IE SCOOPY 300 4T-4V 07-19



◀ cod. **RL00032**
Ruota libera completa Yamaha Majesty 125/180 cc (YP) dal '03

RIFERIMENTO ORIGINALE

Yamaha	5XME55700000	Mbk	5XME55700000
--------	--------------	-----	--------------

APPLICABILITÀ

MBK SKYLINER E 125 4T 03-03, SKYLINER E 180 4T 03-03 **YAMAHA** MAJESTY E 125 4T 03-09, MAJESTY E 180 4T 03-06



◀ cod. **RL00033**
Ruota libera Kymco Agility 50 cc

RIFERIMENTO ORIGINALE

Kymco	00107245
-------	----------

APPLICABILITÀ

KYMCO AGILITY 4T CARRY 50 4T 11-11, AGILITY 4T R10 50 4T 06-08, AGILITY 4T R12 50 4T 07-08, AGILITY PLUS 4T 50 4T 14-14, AGILITY R12 50 4T 05-05, AGILITY R12 ECS 50 4T 16-16, AGILITY R16 50 4T 08-09, AGILITY R16 50 4T 12-12, AGILITY R16 2T 50 2T 10-10, AGILITY R16 2T 50 2T 12-12, AGILITY RS 50 4T 09-09, AGILITY RS NAKED 50 2T 10-10, B&W 50 2T 02-02, B&W EU2 50 2T 03-03, DINK AC 50 2T 98-02, DINK LC 50 2T 98-02, DINK 50 4T 50 4T 07-07, DINK CLASSIC EU2 50 2T 03-03, FILLY 50 4T 98-00, FILLY LX 50 4T 01-02, HEROISM 50 2T 95-97, LIKE 50 4T 09-09, PEOPLE 50 2T 99-04, PEOPLE EURO 2 50 2T 03-03, PEOPLE EURO 2 50 2T 08-08, PEOPLE EURO 2 50 2T 11-11, PEOPLE S 50 2T 05-08, PEOPLE S 4T 50 4T 06-08, SENTO 50 4T 08-08, SNIPER 50 2T 93-93, SNIPER DD 50 2T 94-96, SUPER 8 50 2T 09-09, SUPER 8 4T 50 4T 07-07, SUPER 8 4T 50 4T 09-09, SUPER 9 50 2T 00-00, SUPER 9 EU2 50 2T 03-04, TOP BOY 50 2T 97-00, VITALITY 2T 50 2T 04-04, VITALITY 4T 50 4T 04-04, YUP 50 2T 02-02, YUP EU2 50 2T 03-03

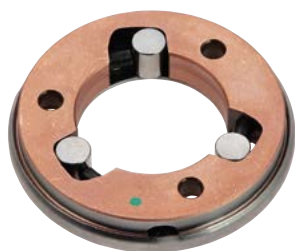

◀ cod. **RL00034**
Ruota libera Yamaha X-Max 125 cc

RIFERIMENTO ORIGINALE

Yamaha	1B9E55800000	Mbk	1B9E55800000
--------	--------------	-----	--------------

APPLICABILITÀ

MBK CITYLINER EU3 125 4T-4V 08-10, SKYCRUISER 125 4T-4V 07-07 **YAMAHA** X-CITY EU3 125 4T-4V 08-11, X-MAX R 125 4T-4V 06-16, X-MAX R ABS 125 4T-4V 11-11, X-MAX RA ABS 125 4T-4V 13-16



◀ cod. **RL00035**
Ingranaggio ruota libera Yamaha X-Max 125 cc

RIFERIMENTO ORIGINALE

Yamaha	5YPE55240000	Mbk	5YPE55240000
--------	--------------	-----	--------------

APPLICABILITÀ

MBK CITYLINER EU3 125 4T-4V 08-10, SKYCRUISER 125 4T-4V 07-07 **YAMAHA** X-CITY EU3 125 4T-4V 08-11, X-MAX R 125 4T-4V 06-16, X-MAX R ABS 125 4T-4V 11-11, X-MAX RA ABS 125 4T-4V 13-16

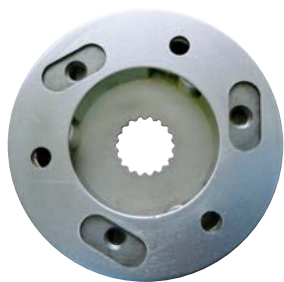

◀ **cod. RL00038**
Ruota libera Yamaha Xenter 125 cc

RIFERIMENTO ORIGINALE

Yamaha	52SE55700000
--------	--------------

APPLICABILITÀ

YAMAHA XC125R MAJESTY S 125 4T 14-14, XENTER 125 4T 12-17, XENTER 150 4T 12-16



◀ **cod. RL00022**
Ruota Libera Piaggio Liberty 125 cc

RIFERIMENTO ORIGINALE

Piaggio	82612R
---------	--------

APPLICABILITÀ

APRILIA ATLANTIC 125 4T 03-05, ATLANTIC EU3 125 4T 06-08, ATLANTIC EU3 125 4T 10-12, MOJITO 125 4T 03-08, SCARABEO 125 4T 03-06, SCARABEO EU3 125 4T 06-07, SPORT CITY 125 4T 04-06, SPORT CITY CUBE 125 4T 08-10, SPORT CITY EU3 125 4T 06-08, SPORT CITY ONE 4T EU3 125 4T 08-11, SPORT CITY STREET 125 4T 12-12, SR MOTARD 125 4T-2V 12-14, MOJITO 150 4T 03-07, SCARABEO 150 4T 04-06, ATLANTIC 200 4T 03-05, SCARABEO 200 4T 03-03, SCARABEO EU3 200 4T 06-06, SPORT CITY 200 4T 04-06, SPORT CITY CUBE 200 4T 08-10, SPORT CITY EU3 200 4T 06-08

DERBI BOULEVARD 125 4T 02-04, BOULEVARD 4T EU3 125 4T 08-12, BOULEVARD EU2 125 4T 04-07, GP1 EU 2 125 4T 06-06, GP1 LOW SEAT EU3 125 4T 07-08, RAMBLA 125 4T 08-09, RAMBLA EU3 2VER 125 4T 08-08, SONAR 4T 125 4T 09-11, VARIANT SPORT 4T EU3 125 4T 12-12, BOULEVARD 150 4T 02-04, BOULEVARD 4T E3 150 4T 10-10, BOULEVARD EU3 150 4T 04-07, SONAR 4T 150 4T 09-09, BOULEVARD EU2 200 4T 05-06

GILERA DNA 125 4T 01-01, NEXUS EU3 125 4T 07-08, RUNNER 4T ST EU3 125 4T 08-16, RUNNER VX 125 4T 00-06, RUNNER VX 4T EU3 125 4T 06-07, RUNNER VX RACE 125 4T 06-06, RUNNER VX SC 125 4T 06-07, RUNNER VXR RACE 200 125 4T 06-06, DNA 180 4T 01-01, RUNNER VXR 180 4T 00-01, RUNNER VXR 200 4T 02-06, RUNNER VXR 4T ST EU3 200 4T 08-11, RUNNER VXR EU3 200 4T 07-07

PIAGGIO BEVERLY 125 4T 01-03, BEVERLY EU3 125 4T 07-08, BEVERLY EURO 3 MIC 125 4T 07-07, BEVERLY EURO 3 SPORT 125 4T 07-08, BEVERLY RST 125 4T 04-07, BEVERLY TOURER EU3 125 4T 07-10, CARNABY 125 4T 07-10, FLY 125 4T 05-07, FLY EU3 125 4T 07-11, HEXAGON GTX 125 4T 00-00, LIBERTY 125 4T 98-02, LIBERTY 4T 125 4T 06-07, LIBERTY 4T 2V EURO3 125 4T 09-12, LIBERTY 4T EU3 125 4T 06-08, LIBERTY 4T EU3 DELIVERY - TNT 125 4T 08-15, LIBERTY 4T SPORT EU3 125 4T 06-08, LIBERTY RST 125 4T 04-05, LIBERTY RST PTT 125 4T 05-11, LIBERTY SPORT 125 4T 06-06, MP3 125 4T 06-08, SKYPPER 4T 125 4T 00-02, SUPER HEXAGON GTX 12 125 4T 01-02, TYPHOON 4T 2V E3 125 4T 10-11, VESPA ET4 125 4T 96-02, VESPA GRANTURISMO 125 4T 03-07, VESPA GRANTURISMO EU3 125 4T 06-07, VESPA GTS EU3 125 4T 07-12, VESPA GTV 125 4T 06-08, VESPA GTV 4T NAVY EU3 125 4T 08-08, VESPA LX 125 4T 05-06, VESPA LX 4T EU3 TOURING 125 4T 10-11, VESPA LX 4T FL 125 4T 09-09, VESPA LX EU3 125 4T 06-08, VESPA LX EU3 IE 125 4T 09-11, VESPA LXV 4T EU3 125 4T 06-09, VESPA LXV IE 4T 125 4T 10-13, VESPA LXV NAVY EU3 125 4T 07-08, VESPA S 4T EU3 125 4T 07-08, VESPA S 4T IE & COLLEGE 125 4T 09-11, X-EVO 125 4T 07-16, X7 EU3 125 4T 08-08, X8 125 4T 04-06, X8 PREMIUM EU2 125 4T 06-06, X8 PREMIUM EU3 125 4T 06-07, X8 STREET EU2 125 4T 06-07, X9 125 4T 01-02, X9 EVOLUTION 125 4T 03-03, X9 EVOLUTION 125 4T 05-06, X9 EVOLUTION EU3 125 4T 07-07, ZIP 125 4T 00-02, FLY 150 4T 05-07, FLY EU3 150 4T 08-11, LIBERTY 150 4T 01-02, LIBERTY 4T EU3 150 4T 08-08, LIBERTY 4T SPORT EU3 150 4T 08-08, LIBERTY MOC 4T 150 4T 09-13, SKYPPER 4T 150 4T 00-02, VESPA ET4 150 4T 99-02, VESPA LX 150 4T 05-06, VESPA LX 4T FL 150 4T 09-09, VESPA LX EU3 150 4T 06-08, VESPA LX EU3 IE 150 4T 09-11, VESPA LX TOURING 150 4T 10-12, VESPA S 4T 150 4T 08-09, VESPA S 4T IE & COLLEGE 150 4T 09-12, X8 STREET EU2 150 4T 06-08, HEXAGON GTX 180 4T 00-00, SUPER HEXAGON GTX 12 180 4T 01-02, X9 AMALFI 180 4T 00-03, BEVERLY 200 4T 01-03, CARNABY 200 4T 07-08, LIBERTY 200 4T 06-06, LIBERTY 4T EU3 200 4T 06-08, LIBERTY 4T SPORT EU3 200 4T 06-07, LIBERTY RST 200 4T 04-04, LIBERTY SPORT 200 4T 06-06, VESPA GRANTURISMO 200 4T 03-07, X8 200 4T 04-07, X9 200 4T 02-03, X9 EVOLUTION 200 4T 03-03



◀ **cod. RL00039**
Ruota Libera Piaggio Liberty 50 cc 4T

RIFERIMENTO ORIGINALE

Piaggio	289202
---------	--------

APPLICABILITÀ

APRILIA RS 50 2T 06-10, RS4 50 2T 11-13, SCARABEO 4T 50 4T 02-06, SCARABEO 4T 4V 50 4T-4V 10-12, SCARABEO 4T 4V NET 50 4T-4V 09-10, SCARABEO 4T RESTYLING EU3 50 4T 06-09, SCARABEO QUATTRO 50 4T-4V 09-09, SPORT CITY ONE 4T 50 4T 08-10, SR R 50 2T 04-09, SR R FACTORY IE 50 2T 10-14

DERBI ATLANTIS 4T 50 4T 04-06, ATLANTIS 4T EU2 50 4T 07-07, BOULEVARD 4T EU2 25KM/H 50 4T 09-09, GPR 2T EU2 50 2T 09-10, GPR NUDE & GPR NUDE TUNING 50 2T 06-08, GPR NUDE SPORT 50 2T 06-06, GPR RACING EU2 50 2T 06-06, GPR REPLICCA & GPR R EU2 50 2T 06-06, GPR REPLICCA PESEK EU2 50 2T 07-07, SENDA R DRD PRO EU2 50 2T 05-11, SENDA SM DRD PRO EU2 50 2T 05-11

GILERA RUNNER PURE JET 50 2T-IE 02-07, RUNNER PURE JET 50 2T-IE 10-11

MALAGUTI CENTRO EURO 2 50 4T 08-08, CENTRO SL 4T 50 4T 10-10, CIAK MASTER 4T 50 4T 05-06

PIAGGIO FLY 4T 50 4T 05-07, FLY 4T & 25-30 KM/H 50 4T 08-11, FLY 4T MOTORE CHN 50 4T 06-07, LIBERTY 4T 50 4T 00-02, LIBERTY 4T 50 4T 05-08, LIBERTY 4T 3V IE 50 4T-3V 15-17, LIBERTY 4T 3V IE E4 50 4T-3V 17-18, LIBERTY 4T DELIVERY - SINGLE 50 4T 10-14, LIBERTY 4T DELIVERY TNT 50 4T 09-09, LIBERTY 4T PTT - DOUBLE - NEXIVE 50 4T 09-17, LIBERTY 4T RST 50 4T 04-04, LIBERTY 4T SPORT 50 4T 06-08, LIBERTY MOC 2T & ELLE 50 2T 09-13, NRG POWER PUREJET 50 2T-IE 04-11, NRG PUREJET 50 2T-IE 02-04, NRG PUREJET 50 2T-IE 10-10, VESPA ET4 50 4T 00-05, VESPA LX 4T 50 4T 05-09, VESPA LX 4T 4V 50 4T-4V 09-13, VESPA LX 4T 4V TOURING 50 4T-4V 10-13, VESPA S 4T 4V & COLLEGE 50 4T-4V 08-12, ZIP 4T 50 4T 00-13, ZIP RST 50 2T 96-99



◀ **cod. RL00040**
Ruota Libera Piaggio Liberty 50 cc 2T

RIFERIMENTO ORIGINALE

Piaggio	286174
---------	--------

APPLICABILITÀ

APRILIA SCARABEO 2T EU2 MOTORE PIAGGIO 50 2T 10-12, SCARABEO 2T NET 50 2T 09-10, SCARABEO STREET 50 2T 05-06, SCARABEO STREET 2T RESTYLING 50 2T 06-09, SPORT CITY ONE 2T 50 2T 08-11, SR MOTARD 50 2T 12-14, SR R FACTORY CARBURATORE 50 2T 10-14, SR STEALTH 50 2T 97-00, SR STREET CARBURATORE 50 2T 03-12

DERBI ATLANTIS 2T 50 2T 10-10, ATLANTIS 2T EU2 50 2T 07-09, ATLANTIS O2 50 2T 02-02, ATLANTIS O2 BULLET 50 2T 03-05, ATLANTIS O2 CITY 50 2T 04-06, ATLANTIS O2 RED BULLET 50 2T 03-03, ATLANTIS O2 TWO CHIC 50 2T 05-05, BOULEVARD 2T 50 2T 09-14, GP1 50 2T 01-03, GP1 EU 2 50 2T 05-05, GP1 OPEN EU2 50 2T 06-09, GP1 RACE EU2 50 2T 05-07, SONAR 2T 50 2T 09-09

GILERA DNA 50 2T 00-02, DNA 50 2T 05-07, DNA GP EXPERIENCE 50 2T 03-04, EASY MOVING 50 2T 95-96, ICE 50 2T 01-05, RUNNER 50 2T 97-00, RUNNER POGGIALI 50 2T 02-02, RUNNER SP 50 2T 02-07, RUNNER SP 50 2T 10-12, RUNNER SP SPECIAL EDITION 50 2T 07-07, RUNNER SP ST & SIMONCELLI 50 2T 08-09, STALKER 50 2T 97-11, STALKER NAKED 50 2T 08-08, STALKER SPECIAL EDITION 50 2T 07-08, STORM 50 2T 94-95, STORM EURO 2 50 2T 07-07, TYPHOON 50 2T 94-97, TYPHOON X 50 2T 98-99, TYPHOON XR 50 2T 00-00

KYMCO AGILITY 4T CARRY 50 4T 11-11, AGILITY 4T R10 50 4T 06-08, AGILITY 4T R12 50 4T 07-08, AGILITY R12 50 4T 05-05, AGILITY R16 50 4T 08-09, AGILITY R16 50 4T 12-12, AGILITY R16 2T 50 2T 10-10, AGILITY R16 2T 50 2T 12-12, AGILITY RS 50 4T 09-09, AGILITY RS NAKED 50 2T 10-10, B&W 50 2T 02-02, B&W EU2 50 2T 03-03, DINK AC 50 2T 98-02, DINK LC 50 2T 98-02, DINK 50 4T 50 4T 07-07, DINK CLASSIC EU2 50 2T 03-03, FILLY 50 4T 98-00, FILLY LX 50 4T 01-02, HEROISM 50 2T 95-97, LIKE 50 4T 09-09, PEOPLE 50 2T 99-04, PEOPLE EURO 2 50 2T 03-03, PEOPLE EURO 2 50 2T 08-08, PEOPLE EURO 2 50 2T 11-11, PEOPLE S 50 2T 05-08, PEOPLE S 4T 50 4T 06-08, SENTO 50 4T 08-08, SNIPER 50 2T 93-93, SNIPER DD 50 2T 94-96, SUPER 8 50 2T 09-09, SUPER 8 4T 50 4T 07-07, SUPER 8 4T 50 4T 09-09, SUPER 9 50 2T 00-00, SUPER 9 EU2 50 2T 03-04, TOP BOY 50 2T 97-00, VITALITY 2T 50 2T 04-04, VITALITY 4T 50 4T 04-04, YUP 50 2T 02-02, YUP EU2 50 2T 03-03

PIAGGIO DIESIS 50 2T 01-01, FLY 2T 50 2T 05-07, FLY 2T 50 2T 10-11, FREE 50 2T 92-94, FREE DELIVERY 50 2T 00-01, FREE FL 50 2T 95-02, LIBERTY 50 2T 97-05, LIBERTY 2T 50 2T 06-08, LIBERTY 2T PTT EU2 50 2T 04-05, LIBERTY 2T RST 50 2T 04-04, LIBERTY 2T SPORT 50 2T 06-08, NRG 50 2T 94-96, NRG EXTREME LC 50 2T 99-00, NRG MC3 50 2T 01-04, NRG POWER DD 50 2T 05-17, NRG POWER DD SERIE SPECIALE 50 2T 07-12, NRG POWER DT 50 2T 06-15, NRG POWER DT SERIE SPECIALE 50 2T 07-08, NRG RST MC2 50 2T 96-98, NTT 50 2T 95-96, QUARTZ 50 2T 92-96, SFERA 50 2T 91-93, SFERA MAQUILLAGE 2 50 2T 94-94, SFERA RST 50 2T 95-97, TYPHOON 50 2T 01-11, TYPHOON 2T E2 50 2T 10-12, TYPHOON 2T E3 CH 50 2T 11-11, VESPA ET2 50 2T 97-05, VESPA ET2 INIEZIONE 50 2T 97-00, VESPA LX 2T 50 2T 05-08, VESPA LX 2T TOURING & 30KM 50 2T 10-13, VESPA LXV 2T 50 2T 06-09, VESPA LXV 2T NAVY 50 2T 08-08, VESPA S 2T & COLLEGE 50 2T 07-12, ZIP 50 2T 92-93, ZIP 50 2T 95-96, ZIP 2T 50 2T 08-13, ZIP BIMODALE 50 2T 94-97, ZIP FAST RIDER 50 2T 93-94, ZIP FAST RIDER RST 50 2T 96-97, ZIP LC 50 2T 00-04, ZIP SP 50 2T 96-04, ZIP SP EURO 2 50 2T 06-13



◀ **cod. RL00041**
Ruota Libera Piaggio Beverly 125/250 cc

RIFERIMENTO ORIGINALE

Piaggio	8477975T
---------	----------

APPLICABILITÀ

APRILIA ATLANTIC EU3 125 4T 06-08, SPORT CITY EU3 125 4T 06-08, SR MAX 125 4T 11-14, ATLANTIC EU3 250 4T 06-08, SCARABEO LIGHT 250 4T 06-08, SPORT CITY CUBE 250 4T 08-12

DERBI RAMBLA 125 4T 08-09, RAMBLA EU3 2VER 125 4T 08-08, GP1 LOW SEAT EU3 250 4T 07-08, RAMBLA 250 4T 08-09, RAMBLA EU3 2VER 250 4T 08-08

GILERA NEXUS IE EU3 125 4T 08-10, NEXUS EU3 250 4T 06-07, NEXUS SP EU3 250 4T 06-07

PIAGGIO BEVERLY RST 4T 4V IE EU3 125 4T 10-15, MP3 IBRIDO 125 4T 09-10, MP3 IE 125 4T 08-09, MP3 IE TOURING 125 4T 11-12, VESPA GTS 4T IE SUPER 125 4T 09-16, X7 EVO IE EU3 125 4T 09-10, BEVERLY CRUISER 250 4T 07-09, BEVERLY EURO 3 MIC 250 4T 07-07, BEVERLY IE EU3 250 4T 06-08, BEVERLY SPORT 250 4T 06-08, BEVERLY TOURER EU3 250 4T 07-09, CARNABY 250 4T 08-09, MP3 250 4T 06-08, MP3 LT 250 4T 08-09, MP3 MIC 250 4T 08-09, VESPA GT 60 EU3 250 4T 06-07, VESPA GTS 250 4T 05-16, VESPA GTV 250 4T 06-09, VESPA GTV 4T NAVY EU3 250 4T 07-07, X-EVO 250 4T 07-16, X7 EU3 250 4T 08-08, X8 EU3 250 4T 05-08



◀ **cod. RL00043**
Ruota libera Yamaha T-MAX 530/560 cc dal 2015

RIFERIMENTO ORIGINALE

Yamaha	1WS155900000
--------	--------------

APPLICABILITÀ

YAMAHA T-MAX 59C 530 4T 15-16, T-MAX 59C ABS 530 4T 15-16, T-MAX 59C SP 530 4T 15-15, T-MAX 59C SP ABS 530 4T 15-16, XPS30-A T-MAX SX 530 4T 17-19, XPS30D-A T-MAX DX 530 4T 17-19, XPS30E-A T-MAX 530 4T 17-18, MT-07 700 4T 14-16, MT-07 MC MOTO CAGE 700 4T 14-14, MT-07A 700 4T 17-17, MT-07A ABS 700 4T 14-16, MT-07A MC MOTO CAGE 700 4T 14-14, MTT690-A TRACER 700 4T 16-16, XSR 700 4T 16-18

ALBERI ENTRATA MOTO



- ◀ cod. **C107488**
Ingranaggio doppio intermedio Z=12/48 motore scooter 50 cc Minarelli/Yamaha orizzontale corto
- ◀ cod. **C107489**
Ingranaggio doppio intermedio Z=13/52 motore scooter 50 cc Minarelli/Yamaha verticale e orizzontale lungo

ALBERI USCITA MOTO



- ◀ cod. **C107480**
Albero uscita moto Z=44 motore scooter 50 cc Minarelli/Yamaha verticale e orizzontale lungo
- ◀ cod. **C107481**
Albero uscita moto Z=43 motore scooter 50 cc Minarelli/Yamaha verticale e orizzontale lungo



- ◀ cod. **C107491**
Albero uscita moto per motore scooter 50 cc Piaggio/Gilera

RIFERIMENTO ORIGINALE

Piaggio	478155
---------	--------



- ◀ cod. **C107492**
Albero uscita moto per motore scooter Piaggio/Gilera 125/150 cc

RIFERIMENTO ORIGINALE

Piaggio	478156
---------	--------

ALBERI MESSA IN MOTO



- ◀ cod. **CI07487**
Albero messa in moto motore scooter 50 cc Minarelli/Yamaha verticale e orizzontale lungo



- ◀ cod. **CI07494**
Albero messa in moto per motore scooter 50 cc Piaggio/Gilera

- ◀ cod. **CI07495**
Albero messa in moto per motore scooter 50 cc Peugeot



- ◀ cod. **CI07497**
Albero messa in moto Vespa PX 125-150-200 cc

RIFERIMENTO ORIGINALE

Piaggio	148570
---------	--------



- ◀ cod. **CI07498**
Albero messa in moto Vespa ET3-50PK-Primavera

RIFERIMENTO ORIGINALE

Piaggio	0789766
---------	---------



- ◀ cod. **CI07499**
Ingranaggio doppio intermedio avviamento scooter Minarelli 50 cc

INGRANAGGI AVVIAMENTO



◀ cod. **C107490**
Ingranaggio scorrevole messa in moto per motore scooter 50 cc Minarelli/Yamaha



◀ cod. **C107493**
Ingranaggio scorrevole messa in moto per motore scooter Piaggio 50 cc



◀ cod. **C107496**
Ingranaggio avviamento Vespa PX 125-150-200 cc

RIFERIMENTO ORIGINALE

Piaggio	1135264
---------	---------

GABBIA / MOLLE / SCODELLINO



◀ cod. **AA00767**
Gabbia a rulli per ruota libera 57x61x10 per motore scooter 50 cc Minarelli/Yamaha



◀ cod. **AA00768**
Molla per scorrevole messa in moto per motore scooter 50 cc Minarelli/Yamaha



◀ cod. **AA00800**
Scodellino dentato per motore scooter 50 cc Gilera/Piaggio

GRUPPI INGRANAGGI SECONDARI



◀ cod. **CI07450**
Coppia ingranaggi secondari
Scarabeo '96 - Carosello
Numero denti: 12/44 - Rapporto: 1:3,66

◀ cod. **CI07451**
Coppia ingranaggi secondari Minarelli/Yamaha
Flipper - Why
Numero denti: 13/43 - Rapporto: 1:3,30

◀ cod. **CI07452**
Coppia ingranaggi secondari Minarelli/Yamaha
Booster
Numero denti: 13/42 - Rapporto: 1:3,23

INTERMITTENZE



◀ cod. **ME00001**
Intermittenza frecce Vespa PX125-150-200

RIFERIMENTO ORIGINALE

Piaggio	195703
---------	--------

MAXI SCOOTER



◀ cod. **SG15709**
Serie segmenti tipo originale per Kymco 125 cc

RIFERIMENTO ORIGINALE

Kymco	00123728
-------	----------

APPLICABILITÀ

KYMCO AGILITY R16 125 4T 08-09, B&W 125 4T 00-00, DINK 125 4T 97-98, DINK CLASSIC 125 4T 02-02, DINK CLASSIC EU2 125 4T 03-03, DINK LX 125 4T 98-00, GRAND DINK 125 4T 01-02, HEROISM 125 4T 95-97, LIKE 125 4T 09-09, MOVIE 125 4T 99-00, MOVIE EU3 125 4T 06-07, MOVIE XL 125 4T 01-01, PEOPLE 125 4T 99-00, PEOPLE EU3 125 4T 07-08, SUPER 8 125 4T 08-09, VIVIO 125 4T 00-00

◀ cod. **SG15710**
Serie segmenti tipo originale per Kymco 150 cc

RIFERIMENTO ORIGINALE

Kymco	00123740
-------	----------

APPLICABILITÀ

KYMCO AGILITY R16 150 4T 08-09, B&W 150 4T 00-00, DINK 150 4T 97-98, DINK CLASSIC 150 4T 02-02, DINK CLASSIC EU2 150 4T 03-03, DINK LX 150 4T 98-00, GRAND DINK 150 4T 01-02, HEROISM 150 4T 95-97, MOVIE EU3 150 4T 06-07, PEOPLE 150 4T 99-00, VIVIO 150 4T 00-00

◀ cod. **SG15711**
Serie segmenti tipo originale per Honda Pantheon 150

APPLICABILITÀ

HONDA PANTHEON [FES] 150 2T 98-02

◀ cod. **SG15712**
Serie segmenti tipo originale per Suzuki Burgman 400

RIFERIMENTO ORIGINALE

Suzuki	12140-15F00-000
--------	-----------------

APPLICABILITÀ

SUZUKI AN BURGMAN K3/K6 400 4T 03-06, AN BURGMAN X/K2 400 4T 99-02



◀ cod. **SD00002**
Statore per 50 cc Minarelli/Yamaha volano **Ducati**



◀ cod. **SD00010**
Statore per Minarelli AM6 volano **Ducati** (cavo lungo)

◀ cod. **SD00011**
Statore per Minarelli AM6 volano **Ducati** (cavo corto)



◀ cod. **ST00002**
Statore completo per motore Minarelli/Yamaha 125 cc

RIFERIMENTO ORIGINALE

Yamaha	5DSH55100000
--------	--------------

Mbk	5DSH55100000
-----	--------------

APPLICABILITÀ

MBK DOODO 125 4T 00-00, SKYLINER 125 4T 98-02, SKYLINER E 125 4T 03-03, THUNDER 125 4T 01-02, DOODO 150 4T 01-02, SKYLINER 150 4T 00-02, THUNDER 150 4T 01-02, SKYLINER E 180 4T 03-03

YAMAHA MAJESTY 125 4T 98-00, MAJESTY (SNR1) 125 4T 01-01, MAJESTY (SNR8) 125 4T 02-02, MAJESTY E 125 4T 03-09, MAXSTER 125 4T 01-02, TEO'S 125 4T 00-00, MAJESTY 150 4T 00-00, MAJESTY (SNS1) 150 4T 01-01, MAJESTY (SNS6) 150 4T 02-02, MAXSTER 150 4T 01-02, TEO'S 150 4T 01-02, MAJESTY E 180 4T 03-06



◀ cod. **ST00004**
Statore per scooter 50 cc 4T Piaggio/Gilera

RIFERIMENTO ORIGINALE

Piaggio	969228
Aprilia	969228

Derbi	969228
-------	--------

APPLICABILITÀ

APRILIA SCARABEO 4T 50 4T 02-06, SCARABEO 4T RESTYLING EU3 50 4T 06-09, SPORT CITY ONE 4T 50 4T 08-10, SCARABEO 4T 100 4T 01-05, SCARABEO 4T 100 4T 10-12, SCARABEO 4T NET 100 4T 09-09, SCARABEO 4T NET EU3 100 4T 10-10, SCARABEO 4T RESTYLING 100 4T 06-09

DERBI ATLANTIS 4T 50 4T 04-06, ATLANTIS 4T EU2 50 4T 07-07, BOULEVARD 4T EU2 25KM/H 50 4T 09-09, BOULEVARD 4T 100 4T 10-11

PIAGGIO FLY 4T 50 4T 05-07, FLY 4T & 25-30 KM/H 50 4T 08-11, FLY 4T MOTORE CHN 50 4T 06-07, LIBERTY 4T 50 4T 00-02, LIBERTY 4T 50 4T 05-08, LIBERTY 4T 3V IE 50 4T 3V 15-17, LIBERTY 4T 3V IE E4 50 4T 3V 17-18, LIBERTY 4T DELIVERY - SINGLE 50 4T 10-14, LIBERTY 4T DELIVERY TNT 50 4T 09-09, LIBERTY 4T PTT - DOUBLE - NEXIVE 50 4T 09-17, LIBERTY 4T RST 50 4T 04-04, LIBERTY 4T SPORT 50 4T 06-08, LIBERTY MOC 4T & ELLE 50 4T 09-16, VESPA ET4 50 4T 00-05, VESPA LX 4T 50 4T 05-09, ZIP 4T 50 4T 00-13, FLY 100 4T 06-14, FREE 100 4T 02-03, ZIP 4T 100 4T 06-10



◀ cod. **ST00005**
Statore per scooter 500 cc Piaggio

RIFERIMENTO ORIGINALE

Piaggio	58080R
---------	--------

Gilera	58080R
--------	--------

APPLICABILITÀ

APRILIA ATLANTIC SPRINT 400 4T 05-08, SCARABEO LIGHT 400 4T 06-08, ATLANTIC 500 4T 01-04, ATLANTIC SPRINT 500 4T 05-08, SCARABEO 500 4T 03-06, SCARABEO LIGHT 500 4T 06-08
GILERA NEXUS 500 4T 03-05, NEXUS EU3 500 4T 06-11, NEXUS SP EU3 500 4T 06-07

PIAGGIO BEVERLY EU3 400 4T 06-07, X-EVO 400 4T 07-11, X8 EU3 400 4T 06-08, BEVERLY 500 4T 02-06, BEVERLY IE EU3 500 4T 06-08, X9 500 4T 01-02, X9 EVOLUTION 500 4T 03-07, X9 EVOLUTION ABS 500 4T 06-07



◀ cod. **ST00007**
Statore per Derbi Senda 85w (nuovo modello)

RIFERIMENTO ORIGINALE

Derbi	00H03300701
-------	-------------

APPLICABILITÀ

APRILIA RX 50 2T 06-10, SX 50 2T 06-13
DERBI BULTACO LOBITO 50 2T 98-01, SENDA BLACK EDITION 50 2T 03-03, SENDA HYP DRD EVO EU2 50 2T 08-09, SENDA R 50 2T 99-99, SENDA R DRD BLACK DEVIL 2A EDIZIONE 50 2T 03-03, SENDA R DRD EU1 EU1R 50 2T 02-02, SENDA R DRD RACING 50 2T 04-05, SENDA R DRD RACING EU2 50 2T 05-08, SENDA R DRD RACING LTD 50 2T 05-05, SENDA R DRD X-TREME 2T EU2 50 2T 14-15, SENDA R DRD X-TREME 2T EURO2 50 2T 10-12, SENDA R RACER 50 2T 03-03, SENDA R X-RACE 50 2T 04-05, SENDA R X-RACE 2T EU2 50 2T 10-10, SENDA R X-RACE EU2 50 2T 06-09, SENDA R X-TREME 50 2T 05-05, SENDA R X-TREME 2T EU2 50 2T 10-10, SENDA R X-TREME EU2 50 2T 05-08, SENDA SM 50 2T 00-01, SENDA SM DRD EDITION BLACK 50 2T 05-05, SENDA SM DRD EU1 EU1R 50 2T 02-03, SENDA SM DRD RACING 50 2T 04-05, SENDA SM DRD RACING EU2 50 2T 05-08, SENDA SM DRD RACING EU2 50 2T 10-13, SENDA SM DRD RACING LTD 50 2T 05-05, SENDA SM DRD RACING LTD EU2 50 2T 07-07, SENDA SM DRD X-TREME 2T EU2 50 2T 14-15, SENDA SM DRD X-TREME 2T EU2 LIMITED ED 50 2T 14-15, SENDA SM X-RACE 50 2T 04-05, SENDA SM X-RACE 2T EU2 50 2T 10-10, SENDA SM X-RACE EU2 50 2T 06-09, SENDA SM X-RACE EU2 2VER 50 2T 07-09, SENDA SM X-TREME 50 2T 02-03, SENDA SM X-TREME 2T EU2 50 2T 10-10, SENDA SM X-TREME EU2 50 2T 04-08, SENDA SM X-TREME EU2 2A EDIZIONE 50 2T 05-05

GILERA RCR 50 2T 06-07, RCR 50 2T 11-12, RCR (CHE-SYC) 50 2T 13-15, SMT 50 2T 03-03, SMT 50 2T 06-17, SMT RACING 50 2T 11-12



◀ cod. **ST00008**
Statore per Derbi Senda GPR

RIFERIMENTO ORIGINALE

Derbi	00H03360011
-------	-------------

APPLICABILITÀ

APRILIA RS 50 2T 06-10, RS4 50 2T 11-13, RS4 REPLICA 50 2T 14-16, RX 50 2T 14-16, SX 50 2T 14-16, SX LIMITED EDITION 50 2T 14-16

DERBI GPR 2T EU2 50 2T 09-10, GPR NUDE & GPR NUDE TUNING 50 2T 06-08, GPR NUDE SPORT 50 2T 06-06, GPR R EU2 - GPR REPLICA EU2 50 2T 08-08, GPR RACING EU2 50 2T 06-06, GPR REPLICA & GPR R EU2 50 2T 06-06, GPR REPLICA 2T MALOSSÌ 50 2T 07-07, GPR REPLICA PESEK EU2 50 2T 07-07, SENDA HYP DRD EVO LIMITED EDITION EU2 50 2T 08-08, SENDA R DRD PRO EU2 50 2T 05-11, SENDA SM DRD PRO EU2 50 2T 05-11, SENDA SM DRD PRO EU2 2VER 50 2T 05-08

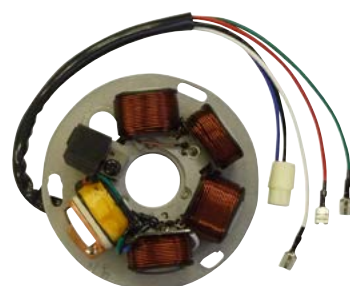

◀ cod. **ST00012**
Statore per Piaggio Vespa PX 125

RIFERIMENTO ORIGINALE

Piaggio	217866
---------	--------

APPLICABILITÀ

PIAGGIO VESPA PX 125 2T 98-01, VESPA PX 125 2T 11-16, VESPA PX 30 ANNI 125 2T 07-08, VESPA PX E ARCOBALENO 125 2T 81-97, VESPA PX EU2 125 2T 01-07, VESPA PX 150 2T 98-01, VESPA PX 150 2T 11-16, VESPA PX E ARCOBALENO 150 2T 81-97, VESPA PX 200 2T 98-01, VESPA PX E ARCOBALENO 200 2T 81-97

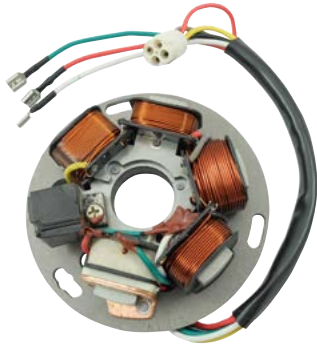

◀ cod. **ST00015**
Statore per Piaggio Vespa 125 Pxe arcobaleno

APPLICABILITÀ

PIAGGIO VESPA PX E ARCOBALENO 125 2T 81-97, VESPA PX E ARCOBALENO 150 2T 81-97, VESPA PX E ARCOBALENO 200 2T 81-97



◀ cod. **ST00019**
Statore Per Yamaha T-Max 500 cc 2004-2007

RIFERIMENTO ORIGINALE

Yamaha	5VU814100000
--------	--------------

APPLICABILITÀ

YAMAHA T-MAX 5VU 500 4T 04-07, T-MAX 5VU ABS 500 4T 05-07, T-MAX 5VU BLACK MAX 500 4T 06-06, T-MAX 5VU BLACK MAX - NIGHT MAX 500 4T 07-07



◀ cod. **ST00020**
Statore Per Yamaha T-Max 530/560 cc

RIFERIMENTO ORIGINALE

Yamaha	59C814100000
--------	--------------

APPLICABILITÀ

YAMAHA T-MAX 59C 530 4T 12-16, T-MAX 59C ABS 530 4T 12-16, T-MAX 59C SP 530 4T 15-15, T-MAX 59C SP ABS 530 4T 15-16, XP530-A T-MAX SX 530 4T 17-19, XP530D-A T-MAX DX 530 4T 17-19, XP530E-A T-MAX 530 4T 17-18



◀ cod. **ST00021**
Statore Per Yamaha T-Max 500 cc 2008-2011

RIFERIMENTO ORIGINALE

Yamaha	4B5814100000
--------	--------------

APPLICABILITÀ

YAMAHA T-MAX 4B5 500 4T 09-11, T-MAX 4B5 ABS 500 4T 08-11, T-MAX 5VU 500 4T 08-08, T-MAX SV 500 4T 11-11, T-MAX SV ABS 500 4T 10-11, T-MAX WHITE MAX 500 4T 10-10



◀ cod. **ST00022**
Statore per Yamaha Majesty 400 cc

APPLICABILITÀ

YAMAHA MAJESTY 400 4T 04-11, MAJESTY ABS 400 4T 07-11, X-MAX 400 4T-4V 13-14, X-MAX ABS 400 4T-4V 14-17, X-MAX IRONMAX ABS 400 4T-4V 16-16, X-MAX MOMO-DESIGN 400 4T-4V 14-14, X-MAX MOMODESIGN ABS 400 4T-4V 14-14, X-MAX RA 400 4T-4V 18-18



◀ cod. **ST00023**
Statore Per Piaggio Beverly 250/300 cc

RIFERIMENTO ORIGINALE

Piaggio	58070R
---------	--------

APPLICABILITÀ

APRILIA ATLANTIC EU3 125 4T 06-08, SPORT CITY EU3 125 4T 06-08, SR MAX 125 4T-4V 11-14, ATLANTIC EU3 250 4T 06-08, SCARABEO LIGHT 250 4T 06-08, SPORT CITY CUBE 250 4T 08-12, SCARABEO LIGHT 300 4T 09-10

DERBI RAMBLA 125 4T 08-09, RAMBLA EU3 2VER 125 4T 08-08, GP1 LOW SEAT EU3 250 4T 07-08, RAMBLA 250 4T 08-09, RAMBLA 300 4T 10-11

GILERA NEXUS IE EU3 125 4T 08-10, NEXUS EU3 250 4T 06-07, NEXUS SP EU3 250 4T 06-07, NEXUS EU3 300 4T 08-11

PIAGGIO MP3 IBRIDO 125 4T 09-10, MP3 IE 125 4T 08-09, BEVERLY CRUISER 250 4T 07-09, BEVERLY EURO 3 MIC 250 4T 07-07, BEVERLY IE EU3 250 4T 06-08, BEVERLY SPORT 250 4T 06-08, BEVERLY TOURER EU3 250 4T 07-09, CARNABY 250 4T 08-09, MP3 250 4T 06-08, MP3 LT 250 4T 08-09, MP3 MIC 250 4T 08-09, VESPA GT 60 EU3 250 4T 06-07, VESPA GTS 250 4T 05-16, VESPA GTS ABS 250 4T 05-12, VESPA GTV 250 4T 06-09, VESPA GTV 4T NAVY EU3 250 4T 07-07, X-EVO 250 4T 07-16, X7 EU3 250 4T 08-08, X8 EU3 250 4T 05-08, BEVERLY TOURER EU3 300 4T 09-10, CARNABY CRUISER 300 4T 09-12, VESPA GTV VIA MONTENAPOLEONE 300 4T 10-10



◀ cod. **ST00024**
Statore Per Honda SH 300 cc 2007-2010

RIFERIMENTO ORIGINALE

Honda	31120-KTW-901
-------	---------------

APPLICABILITÀ

HONDA SH IE SCOOPY 300 4T-4V 07-10



◀ cod. **ST00025**
Statore Kymco Agility 125/150 cc '08-'12

APPLICABILITÀ

KYMCO AGILITY R16 125 4T 08-09, AGILITY R16 125 4T 12-12, AGILITY RS 125 4T 09-09, LIKE 125 4T 09-09, LIKE LX 125 4T 09-09, LIKE LX 125 4T 12-12, AGILITY R16 150 4T 08-09



◀ cod. **ST00026**
Statore Per Honda SH 125 cc le 2005-2012

RIFERIMENTO ORIGINALE

Honda	31120-KTF-640
-------	---------------

APPLICABILITÀ

HONDA SH IE SCOOPY 125 4T-2V 05-12, SH IE SCOOPY 150 4T 05-12



◀ cod. **ST00027**
Statore per Kymco People 125/150 cc

APPLICABILITÀ

KYMCO PEOPLE 125 4T 99-00, PEOPLE EU2 125 4T 03-03, PEOPLE EU3 125 4T 07-08, PEOPLE EU3 125 4T 11-11, PEOPLE 150 4T 99-00, PEOPLE EU2 150 4T 03-03

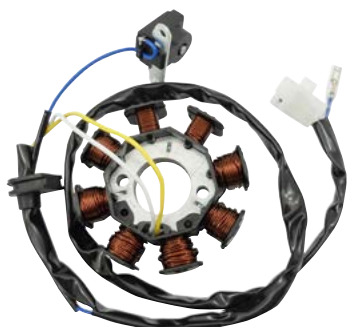

◀ cod. **ST00028**
Statore per Kymco Agility 50 cc 4T '05-'08

APPLICABILITÀ

KYMCO AGILITY 4T R10 50 4T 06-08, AGILITY 4T R12 50 4T 07-08, AGILITY R12 50 4T 05-05, DINK 50 4T 50 4T 07-07, FILLY 50 4T 98-00, FILLY LX 50 4T 01-02, PEOPLE S 4T 50 4T 06-08, SENTO 50 4T 08-08, VITALITY 4T 50 4T 04-04



◀ cod. **ST00029**
Statore per Sym Joyride 125/150/200 cc

APPLICABILITÀ

SYM HD EU2 125 4T-4V 03-04, HD EU3 125 4T-4V 07-08, HD EVO 125 4T-4V 05-06, HD EVO EU3 125 4T-4V 07-08, HD EVO EU3 125 4T-4V 10-11, HD EVO TAMBURO EU3 125 4T-4V 08-09, HD2 125 4T-4V 11-11, HD2 125 4T-4V 14-14, JOYRIDE 125 4T-4V 01-02, JOYRIDE EU2 125 4T-4V 03-06, JOYRIDE EU3 125 4T-4V 07-07, JOYRIDE EVO 125 4T-4V 09-10, JOYRIDE EVO 125 4T-4V 13-14, JOYRIDE 150 4T-4V 01-02, HD EU2 200 4T-4V 03-04, HD EVO EU2 200 4T-4V 05-06, JOYRIDE 200 4T-4V 03-03, JOYRIDE EU2 200 4T-4V 03-06



◀ cod. **ST00032**
Statore 12 poli per motori Minarelli/Yamaha AM6

RIFERIMENTO ORIGINALE

Yamaha	5WXH14100000
--------	--------------

APPLICABILITÀ

BETA RR 2T 50 EU4 502T 18-20, RR 50 RACING EU4 502T 18-20
CMC ENDURO 502T 11-11, MOTARD COMPETITION EU4 502T 11-11
FANTIC CABALLERO MOTARD 502T 10-10, CABALLERO MOTARD COMPETITION 502T 10-10, CABALLERO REGOLARITÀ COMPETITION 502T 10-10, ENDURO COMPETITION EU4 502T 18-20, ENDURO PERFORMANCE EU4 502T 18-20, MOTARD COMPETITION EU4 502T 18-20, MOTARD PERFORMANCE EU4 502T 18-20
HM BAJA, DERAPAGE BASIC 502T 10-11, CMC 502T 10-11, CRE BAJA RR, DERAPAGE RR 502T 10-11, CRE BAJA, DERAPAGE 502T 10-11, CRE SIX COMPETITION 502T 10-11, DERAPAGE COMPETITION 502T 10-11

MINARELLI MOTORE AM 6 2° SERIE 502T 12-18

NOVITÀ

MOTORHISPANIA FURIA MAX 502T 10-12
RIEJU MRT 50 EU4 502T 18-20, MRT PRO EU4 502T 18-20, MRT PRO REPLICAS SM EU4 502T 18-20, MRT PRO SM EU4 502T 18-20, MRT SM EU4 502T 18-20, MRT TROPHY EU4 502T 18-20, RS3 EU4 11-11, RS3 EU4 502T 18-20, RS3 NKD EU4 502T 18-20
SHERCO FACTORY SE-R EU4 502T 18-20, FACTORY SE-RS EU4 502T 18-20, FACTORY SILVER SM-R EU4 502T 18-20, FACTORY SILVER SM-RS EU4 502T 18-20, FACTORY SM-R EU4 502T 18-20, FACTORY SM-RS EU4 502T 18-20
VENT BAJA 50 2T 18-20, BAJA RR 502T 18-20, DERAPAGE 502T 18-20, DERAPAGE RR 502T 18-20



◀ **cod. 27-7015**

Suzuki Stator Coil
0.5k

MAKE / MODEL	YEAR
Suzuki GSX-R600	2001-2003
Suzuki GSX-R750	2000-2003



◀ **cod. 27-7016**

Yamaha Stator Coil
12 Volt

MAKE / MODEL	YEAR
Yamaha YZF-R6	1999-2002



◀ **cod. 27-7017**

Honda Stator Coil
12 Volt

MAKE / MODEL	YEAR
Honda CBR1000RR	2006-2007
Honda CBR1000RR Repsol Edition	2006-2007



◀ **cod. 27-7033**

Suzuki Stator Coil
12 Volt

MAKE / MODEL	YEAR
Suzuki GSX-R600	2011-2015
Suzuki GSX-R750	2011-2015

Poliuretano

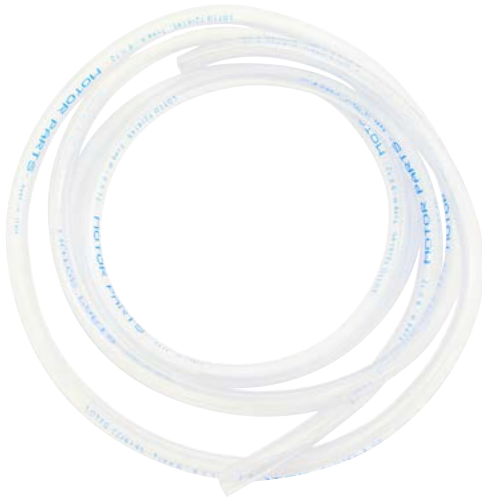

NBR



PVC



CODICE	DESCRIZIONE	Ø	LUNGHEZZA	ASPETTO	MATERIALE	PRESSIONE	INDICE DI DILATAZIONE ΔL%		TEMP. °C	
							BENZINA	OLIO	Min	Max
TB04A01	Tubo benzina Poliuretano	4x7	m 5	Trasparente	PUR	Max 3,5 bar	Minimo	Minimo	-70	110
TB05A01	Tubo benzina Poliuretano	5x10	m 5							
TB06A01	Tubo benzina Poliuretano	6x10	m 5							
TB08A01	Tubo benzina Poliuretano	8x12	m 5							
TB04B01	Tubo benzina NBR	4x7	m 5	Nero	NBR	Low Press	Moderato	Moderato	-20	130
TB05B01	Tubo benzina NBR	5x10	m 5							
TB06B01	Tubo benzina NBR	6x10	m 5							
TB08B01	Tubo benzina NBR	8x12	m 5							
TB04C01	Tubo benzina PVC	4x7	m 5	Trasparente	PVC	Low Press	Medio	Medio	-15	80
TB05C01	Tubo benzina PVC	5x10	m 5							
TB06C01	Tubo benzina PVC	6x10	m 5							
TB08C01	Tubo benzina PVC	8x12	m 5							



◀ **cod. XX01021**
Valvola lamellare per motori scooter 50 cc Minarelli/Yamaha tipo verticale.
Lamella acciaio spess. 0,15 mm

APPLICABILITÀ

APRILIA AMICO 50 2T 94-94, AMICO 50 2T 96-98, AMICO GL/GLE 50 2T 93-95, AMICO LX/SPORT/CAT 50 2T 92-93, SR (VERTICALE) 50 2T 93-93

MBK BOOSTER 50 2T 90-04, BOOSTER 50 2T 90-94, BOOSTER EURO 2 50 2T 04-04, BOOSTER NG 50 2T 95-03, BOOSTER ROCKET 50 2T 97-98, BOOSTER SPIRIT 50 2T 96-00, BOOSTER SPIRIT 50 2T 03-03, BOOSTER SPIRIT EURO2 50 2T 03-03, BOOSTER TRACK 50 2T 96-98, STUNT 50 2T 00-02

YAMAHA BW'S 50 2T 97-16, BW'S BUMP 50 2T 97-98, BW'S EASY 50 2T 13-13, BW'S NAKED 50 2T 03-04, BW'S NAKED 50 2T 09-16, BW'S NEXT GENERATION 50 2T 97-06, BW'S ORIGINAL 50 2T 99-01, BW'S ORIGINAL EURO 2 50 2T 03-03, RS SPY 50 2T 95-98, SLIDER 50 2T 00-02, ZUMA 50 2T 97-10



◀ **cod. XX01022**
Valvola lamellare per motore scooter 50 cc Minarelli/Yamaha tipo orizzontale.
Lamella acciaio spess. 0,15 mm

APPLICABILITÀ

APRILIA AREA 51 50 2T 98-00, GULLIVER 50 2T 95-98, GULLIVER LC 50 2T 96-98, RALLY 50 2T 95-03, RALLY LIQUID COOLED 50 2T 96-99, SCARABEO 50 2T 93-05, SONIC 50 2T 98-07, SONIC GP 50 2T 98-08, SR (ORIZZONTALE) 50 2T 94-96, SR LIQUID COOLED 50 2T 94-96, SR RACING 50 2T 97-99, SR STEALTH 50 2T 97-00, SR WWW 50 2T 97-01

ATALA CAROSELLO 50 2T 99-01

BENELLI 491 GT 50 2T 98-99, 491 NAKED 50 2T 02-02, 491 RACING 50 2T 98-99, 491 RR 50 2T 99-01, 491 SP 50 2T 99-99, 491 SPORT 50 2T 98-99, 491 ST 50 2T 99-01, K2 50 2T 98-01, K2 LIQUID COOLED 50 2T 98-01, PEPE 50 2T 99-01, PEPE LX 50 2T 03-04

BETA ARK 50 2T 96-08, ARK LC 50 2T 96-08, CHRONO 50 2T 95-96, EIKON 50 2T 99-03, QUADRA 50 2T 95-95, QUADRA 50 2T 99-01, TEMPO 50 2T 93-02, TEMPO 50 2T 95-95

ITALJET DRAGSTER 50 2T 98-02

KTM K50 50 2T 96-01

MACAL THUNDER 50 2T 95-96

MALAGUTI CENTRO SL 50 2T 94-98, CIAK 50 2T 99-01, CIAK EURO 2 2,3 50 2T 03-03, CIAK EURO2 50 2T 01-03, CIAK MASTER EURO 2 50 2T 06-06, F10 50 2T 92-00, F10 EURO 2 50 2T 02-06, F10 EURO 2 2,3 50 2T 03-04, F10 RESTYLING EURO 2 50 2T 06-06, F12 PHANTOM 50 2T 94-98, F12 PHANTOM EURO 2 50 2T 02-02, F12 PHANTOM EURO 2 2,3 50 2T 03-04, F12 PHANTOM LC 50 2T 94-98, F12 PHANTOM LC EURO 2 2,3 50 2T 03-04, F12 R PHANTOM LC 50 2T 07-10, F12 RESTYLING EURO 1 50 2T 99-02, F12 RESTYLING EURO 2 50 2T 06-06, F12 RESTYLING LC EURO 2 50 2T 06-06, F15 FIRE FOX 50 2T 96-98, F15 FIRE FOX AIR COOLED 50 2T 05-06, F15 FIRE FOX EURO 2 50 2T 02-06, F15 FIRE FOX EURO 2 2,3 50 2T 03-04, YESTERDAY 50 2T 97-00

MBK EVOLIS 50 2T 92-95, FIZZ 50 2T 94-95, FLIPPER 50 2T 98-04, FLIPPER EURO 2 50 2T 03-03, FORTE 50 2T 94-96, MACH 6 50 2T 02-04, MACH G LC 50 2T 02-04, NITRO 50 2T 97-04, NITRO EURO 2 50 2T 03-03, OVETTO 50 2T 97-04, OVETTO EURO 2 50 2T 02-02

MOTRON SYNCRO 50 2T 98-00, THUNDER 50 2T 95-98

RIEJU FIRST 50 2T 95-98, WINDY 50 2T 95-98

YAMAHA AEROX 50 2T 97-02, AEROX 50 2T 04-16, AEROX EURO 2 50 2T 03-03, AEROX NAKED 50 2T 13-16, AEROX R 50 2T 99-00, AXIS 50 2T 95-96, BREEZE 50 2T 94-95, JOG 50 2T 92-01, JOG R 50 2T 02-02, JOG R EURO2 50 2T 02-02, JOG R EURO2 50 2T 06-15, JOG R LC 50 2T 02-15, NEO'S 50 2T 97-02, NEO'S 50 2T 04-16, NEO'S EASY 50 2T 13-13, NEO'S EURO 2 50 2T 02-02, WHY 50 2T 98-05, WHY EURO 2 50 2T 03-05, ZEST 50 2T 95-92

NOVITÀ



◀ **cod. AM00045**
Valvola lamellare standard per motori Minarelli AM

APPLICABILITÀ

APRILIA CLASSIC 50 2T 92-99, EUROPA 50 2T 91-92, MX 50 2T 04-04, MX MOTARD 50 2T 95-03, PEGASO 50 2T 92-94, RS 50 2T 91-05, RX 50 2T 03-04, RX 3-5 MARCE 50 2T 91-94, RX ENDURO 50 2T 95-03, RX RACING 50 2T 03-06, TUONO 50 2T 03-04

BETA RR 2T 50 EU4 50 2T 18-20, RR 50 RACING EU4 50 2T 18-20, RR ALU 50 2T 08-12, RR ENDURO 50 2T 06-17, RR MOTARD 50 2T 06-17

CH HUSQVARNA SM 50 2T 00-10, WR 50 2T 00-10, WSM 50 2T 00-10

CMC ENDURO 50 2T 11-11, MOTARD 50 2T 11-11

FANTIC CABALLERO MOTARD 50 2T 06-10, CABALLERO MOTARD COMPETITION 50 2T 06-10, CABALLERO REGOLARITÀ 50 2T 06-10, CABALLERO REGOLARITÀ COMPETITION 50 2T 06-10, ENDURO COMPETITION EU4 50 2T 18-20, ENDURO PERFORMANCE EU4 50 2T 18-20, MOTARD COMPETITION EU4 50 2T 18-20, MOTARD PERFORMANCE EU4 50 2T 18-20

HM BAJA, DERAPAGE BASIC 50 2T 10-11, CMC 50 2T 10-11, CRE BAJA RR, DERAPAGE RR 50 2T 07-11, CRE BAJA, DERAPAGE 50 2T 07-11, CRE SIX COMPETITION 50 2T 10-11, CRE SIX, BAJA, DERAPAGE 50 2T 95-06, CRE SIX, DERAPAGE COMPETITION 50 2T 07-09, DERAPAGE COMPETITION 50 2T 10-11

MALAGUTI CNK DRAGON 50 2T 05-07, FIFTY EVOLUTION 50 2T 90-93, XSM 50 2T 03-06, XSM POWER-UP 50 2T 07-10, XTM 50 2T 03-03, XTM 50 2T 06-06, XTM POWER-UP 50 2T 07-10

MBK X LIMIT 50 2T 03-04, X POWER 50 2T 03-04

MINARELLI MOTORE AM 3-4-5 50 2T 91-95, MOTORE AM 6° 1° SERIE 50 2T 96-11, MOTORE AM 6° 2° SERIE 50 2T 12-18

MOTORHISPANIA FURIA 50 2T 97-00, FURIA MAX 50 2T 10-12, RX 50 2T 09-12, RX R 50 2T 09-12

PEUGEOT SUPERMOTARD 50 2T 90-02, XP6 TRAIL S/AVV. ELETTRICO 50 2T 90-02, XR6 RACING CAT. C/AVV.ELETT. 50 2T 90-02

RIEJU MRT 50 2T 09-12, MRT 50 EU4 50 2T 18-20, MRT PRO 50 2T 09-12, MRT PRO EU4 50 2T 18-20, MRT PRO REPLICCA EU4 50 2T 18-20, MRT PRO REPLICCA SM EU4 50 2T 18-20, MRT PRO SM 50 2T 09-12, MRT PRO SM EU4 50 2T 18-20, MRT SM 50 2T 09-12, MRT SM EU4 50 2T 18-20, MRT TROPHY EU4 50 2T 18-20, MRX 50 2T 01-04, MRX PRO 50 2T 01-04, RR 50 2T 05-06, RS1 50 2T 98-01, RS2 MATRIX 50 2T 05-06, RS2 MATRIX PRO 50 2T 05-06, RS2 NAKED 50 2T 04-05, RS3 EU4 50 2T 18-20, RS3 NKD EU4 50 2T 18-20, SMX E.S./K.S. 50 2T 01-01, SMX PRO E.S./K.S. 50 2T 03-03, SPIKE 50 2T 98-01

SHERCO FACTORY SE-R EU4 50 2T 18-20, FACTORY SE-RS EU4 50 2T 18-20, FACTORY SILVER SM-R EU4 50 2T 18-20, FACTORY SILVER SM-RS EU4 50 2T 18-20, FACTORY SM-R EU4 50 2T 18-20, FACTORY SM-RS EU4 50 2T 18-20, HRD ENDURO 50 2T 09-13, HRD MOTARD 50 2T 09-13

YAMAHA DTR 50 2T 03-11, DTR SM 50 2T 03-05, DT X 50 2T 06-11, TZR 50 2T 03-08, TZR 50 2T 10-11, TZR RR 50 2T 05-05









- ◀ cod. **CF12750**
Cilindretto freno Piaggio Ape posteriore

RIFERIMENTO ORIGINALE

Piaggio	127908
---------	--------

APPLICABILITÀ

PIAGGIO APE CAR P2 (1° SERIE) 220 2T 78-82, APE P 501 220 2T 78-85, APE P 601 220 2T 78-83

- ◀ cod. **CF12754**
Cilindretto freno Piaggio Ape posteriore

RIFERIMENTO ORIGINALE

Piaggio	245193
---------	--------

APPLICABILITÀ

PIAGGIO APE TM 220 2T 09-16, APETM P 602 220 2T 82-83, APETM P 703 - P 703 V, FL2 220 2T 84-05

- ◀ cod. **CF12755**
Cilindretto freno Piaggio Ape TM anteriore

RIFERIMENTO ORIGINALE

Piaggio	245194
---------	--------

APPLICABILITÀ

PIAGGIO APETM 220 2T 09-16, APETM P 602 220 2T 82-83, APETM P 703 - P 703 V, FL2 220 2T 84-05

- ◀ cod. **CF12757**
Cilindretto freno Piaggio Ape posteriore

RIFERIMENTO ORIGINALE

Piaggio	245765
---------	--------

APPLICABILITÀ

PIAGGIO APE 50 2T 09-17, APE FL - FL2 50 2T 89-95, APE FL3 EUROPA 50 2T 96-99, APE MIX 2T 50 2T 98-08, APE RST MIX 50 2T 99-03

FILTRI BENZINA



- ◀ cod. **FT07500**
Filtro benzina codulo piccolo Ø 6
(24 pezzi)

- ◀ cod. **FT07501**
Filtro benzina codulo grosso Ø 8
(24 pezzi)



◀ cod. **FZ00301**
Serie dischi frizione vespa 50-90-125 pk
(3 pezzi)

◀ cod. **FZ00302**
Disco frizione singolo vespa 50-90-125 pk
(Conf. da 50 pezzi)



◀ cod. **FZ00303**
Serie dischi frizione
Vespa 125-150 px (3 pezzi)



◀ cod. **FZ00313**
Serie dischi frizione
Vespa px 125 - 150 dal '98

RICAMBI
ML06181 SERIE 8 MOLLE RINFORZATE



◀ cod. **FZ00318**
Serie speciale dischi frizione
Vespa p 200e

RICAMBI
ML00821 SERIE 6 MOLLE RINFORZATE PX 125 -150



◀ cod. **FZ00305**
Serie dischi frizione
Vespa p 200 e (3 pezzi)



◀ cod. **FZ00320**
Massette di trascinamento con molla
per Piaggio - Ciao - Bravo - Si
senza variatore

RIFERIMENTO ORIGINALE
Piaggio 104480



◀ cod. **FZ00306**
Serie speciale dischi frizione
Vespa 50-90-125, 50-125 pk (7 pezzi)

RICAMBI
ML00820 MOLLA RINFORZATA PER VESPA 50



◀ cod. **FZ00329**
Serie dischi frizione
Vespa 50 - 125 fl-hp con 6 molle



◀ cod. **FZ00307**
Serie speciale dischi frizione
Vespa px 125 - 150 (7 pezzi)

RICAMBI
ML00821 SERIE 6 MOLLE RINFORZATE PX 125 -150

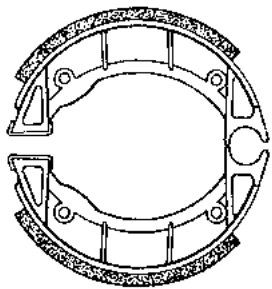

◀ cod. **CP00200**
Coppia ceppi Ø 90 x 18
con molle

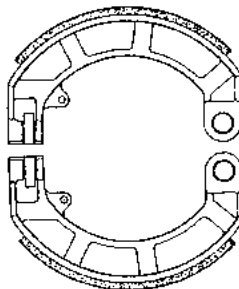

◀ cod. **CP00210**
Coppia ceppi Ø 150x24
Piaggio Vespa

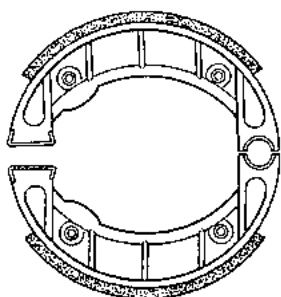

◀ cod. **CP00201**
Coppia ceppi Ø 105 x 20
con molle

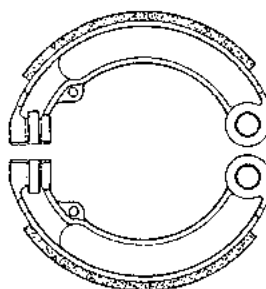

◀ cod. **CP00211**
Coppia ceppi Ø 125x19
Piaggio Vespa

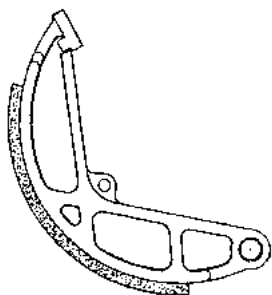

◀ cod. **CP00208**
Ceppo Ciao
Ø 136x17 (serie da 2 pezzi)
posteriore

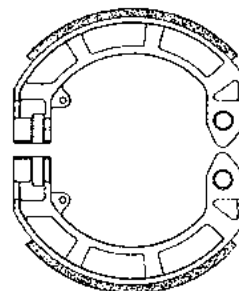

◀ cod. **CP00212**
Coppia ceppi Ø 150 x 24
Piaggio Vespa PX - PK
anteriore e posteriore

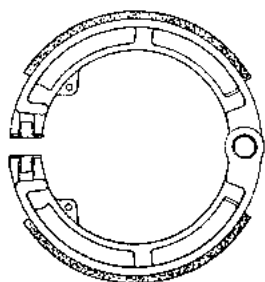

◀ cod. **CP00209**
Coppia ceppi Ø 125x17
Piaggio Vespa

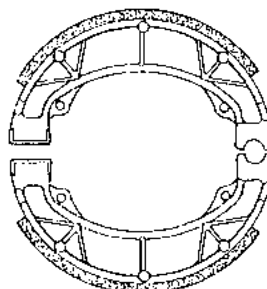

◀ cod. **CP00219**
Coppia ceppi Ø 110 x 25

APPLICABILITÀ

APRILIA Amico, Gulliver, SR post.

MALAGUTI F10, F12, F15 post.

PEUGEOT Geo, Zenith, Buxy, Speedake post.

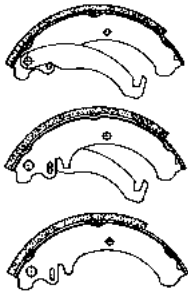

x 2 pezzi

◀ cod. **CP00223**
Serie ceppi Ø 160 x 32
(serie da 4 pezzi)
Piaggio Ape 50
posteriore

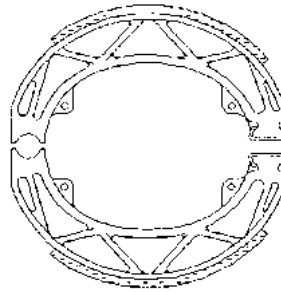

◀ cod. **CP00243**
Coppia ceppi Ø 140 x 25
Piaggio Liberty 50 cc

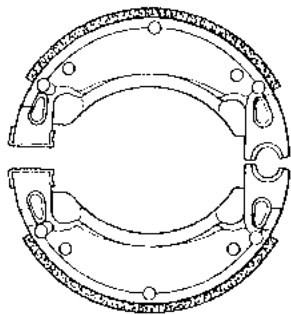

◀ cod. **CP00239**
Coppia ceppi Ø 110 x 25
MBK Booster 50 cc
anteriore e posteriore

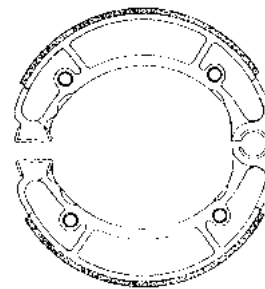

◀ cod. **CP00244**
Coppia ceppi Ø 160 x 30
Yamaha Majesty 250 cc

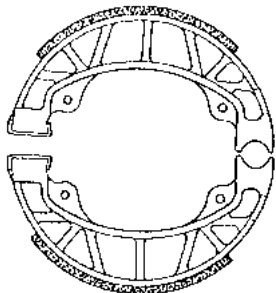

◀ cod. **CP00240**
Coppia ceppi Ø 110 x 25
Piaggio Skipper 50 cc
posteriore

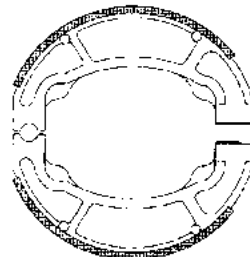

◀ cod. **CP00248**
Coppia ceppi Ø 125 x 25
Honda @ 125/150 cc

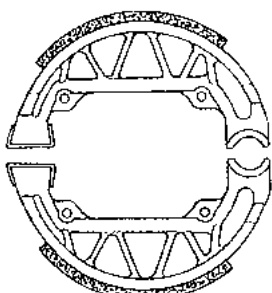

◀ cod. **CP00242**
Coppia ceppi Ø 100 x 20
Sfera 95 (post.)
Quartz-Zip-Typhoon

APPLICABILITÀ

GILERA Typhoon 50 cc (modelli dopo il '95)
PIAGGIO Sfera, Zip, Quartz

CILINDRO IN ALLUMINIO



cod. **KT00135**

Gruppo termico High Performance Ø 57 **Cilindro in alluminio** Piaggio Vespa 125 cc ET3

APPLICABILITÀ

PIAGGIO VESPA ET3 125 2T 76-83, VESPA PRIMAVERA 125 2T 67-83

RICAMBI

GR00748	Serie Guarnizioni
PTA0160	Pistone completo Ø 57 Sel.A
PTB0160	Pistone completo Ø 57 Sel.B

PTC0160	Pistone completo Ø 57 Sel.C
TS00187	Testa
SG15872	Serie segmenti Ø 57 spessore 1,5mm

NOVITÀ

CILINDRO IN ALLUMINIO

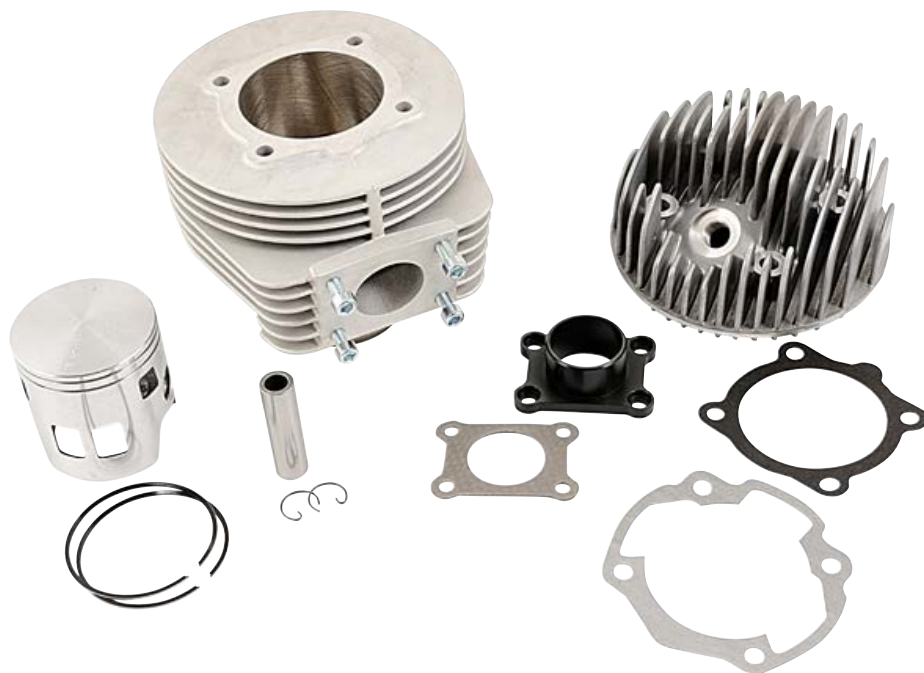

cod. **KT00136**

Gruppo termico High Performance Ø 63 **Cilindro in alluminio** Vespa Px

APPLICABILITÀ

LML STAR DELUXE EU1 125 2T 01-03, STAR DELUXE EU3 125 2T 08-09, STAR DELUXE EU1 150 2T 01-03, STAR DELUXE EU3 150 2T 08-09
PIAGGIO VESPA PX 125 2T 98-01, VESPA PX 125 2T 11-16, VESPA PX 30 ANNI 125 2T 07-08, VESPA PX E ARCOBALENO 125 2T 81-97, VESPA PX EU2 125 2T 01-07, VESPA PX 150 2T 98-01, VESPA PX E ARCOBALENO 150 2T 81-97

RICAMBI

PTA0161	Pistone completo Ø 63 sel. A
PTB0161	Pistone completo Ø 63 sel. B
PTC0161	Pistone completo Ø 63 sel. C
SG15874	Serie Segmenti

GR00752	Serie Guarnizioni
TS00188	Testa
AA00900	Flangia di scarico

ATTENZIONE: QUESTI PRODOTTI SONO DESTINATI ESCLUSIVAMENTE AD USO AGONISTICO. NE È QUINDI VIETATO L'UTILIZZO SU STRADA PUBBLICA.



◀ cod. **KT00004**
Gruppo termico Ø 38,4 Ciao spinotto 12

APPLICABILITÀ

PIAGGIO PIAGGIO: BOSS 50 2T 88-89, BOXER 50 2T 70-83, BRAVO 3 50 2T 87-90, BRAVO ERRE 2 50 2T 75-81, CIAO 50 2T 80-88, CIAO EU1 50 2T 99-01, CIAO EU2 50 2T 02-04, CIAO MIX TEEN 50 2T 96-01, CIAO TRE 50 2T 71-99, GRILLO 50 2T 89-93, SI 50 2T 79-88, SI FL2 50 2T 91-97, SI MIX 50 2T 96-99

RICAMBI

GR06336	Guarnizione Base Ciao
----------------	-----------------------

PT00053	Pistone Ø 38,4 Ciao Sp.12
----------------	---------------------------

◀ cod. **KT00005**
Gruppo termico Ø 38,4 Ciao spinotto 10

APPLICABILITÀ

PIAGGIO BOSS 50 2T 88-89, BOXER 50 2T 70-83, BRAVO 3 50 2T 87-90, BRAVO ERRE 2 50 2T 75-81, CIAO 50 2T 80-88, CIAO EU1 50 2T 99-01, CIAO EU2 50 2T 02-04, CIAO MIX TEEN 50 2T 96-01, CIAO TRE 50 2T 71-99, GRILLO 50 2T 89-93, SI 50 2T 79-88, SI FL2 50 2T 91-97, SI MIX 50 2T 96-99

RICAMBI

GR06336	Guarnizione Base Ciao
----------------	-----------------------

PT00054	Pistone Ø 38,4 Ciao Sp.10
----------------	---------------------------



◀ cod. **KT00010**
Gruppo termico Ø 38,4 per Vespa 50

APPLICABILITÀ

PIAGGIO APE 50 2T 09-17, APE FL - FL2 50 2T 89-95, APE FL3 EUROPA 50 2T 96-99, APE MIX 2T 50 2T 98-08, APE P 50 2T 80-85, APE RST MIX 50 2T 99-03, APE TM P 50 2T 85-89, VESPA FL 50 2T 90-90, VESPA FL2 HP 50 2T 91-97, VESPA N 50 2T 89-90, VESPA PK 50 2T 82-84, VESPA PK XL 50 2T 85-88, VESPA PK XL RUSH 50 2T 88-89, VESPA SPECIAL-L-R 50 2T 67-82

RICAMBI

GR00727	Serie Guarnizioni
PT00057	Pistone completo Ø 38,4

SG15002	Serie Segmenti Ø 38,4
----------------	-----------------------



◀ cod. **KT00113**
Gruppo termico Ø 39 Honda SH-SFX-Bali senza testa

APPLICABILITÀ

HONDA BALI 50 2T 93-99, SFX / SXR 50 2T 95-01, SGX SKY 50 2T 97-04, SH NEW 50 2T 96-01, X8R S 50 2T 98-01, X8R X 50 2T 98-01

RICAMBI

GR00724	Serie Guarnizioni
PT00105	Pistone completo Ø 39

SG15868	Serie Segmenti Ø 39
----------------	---------------------

ATTENZIONE: QUESTI PRODOTTI SONO DESTINATI ESCLUSIVAMENTE AD USO AGONISTICO. NE È QUINDI VIETATO L'UTILIZZO SU STRADA PUBBLICA.

cod. **KT00080** Gruppo termico Ø 40 scooter Piaggio senza testa



APPLICABILITÀ

APRILIA MOJITO CUSTOM 2T MOTORE PIAGGIO 50 2T 04-10, SCARABEO 2T EU2 MOTORE PIAGGIO 50 2T 10-12, SCARABEO 2T NET 50 2T 09-10, SCARABEO STREET 50 2T 05-06, SCARABEO STREET 2T RESTYLING 50 2T 06-09, SPORT CITY ONE 2T 50 2T 08-11

DERBI ATLANTIS 2T 50 2T 10-10, ATLANTIS 2T EU2 50 2T 07-09, ATLANTIS O2 50 2T 02-02, ATLANTIS O2 BULLET 50 2T 03-05, ATLANTIS O2 CITY 50 2T 04-06, ATLANTIS O2 RED BULLET 50 2T 03-03, ATLANTIS O2 TWO CHIC 50 2T 05-05, BOULEVARD 2T 50 2T 09-14, SONAR 2T 50 2T 09-09

GILERA EASY MOVING 50 2T 95-96, ICE 50 2T 01-05, STALKER 50 2T 97-11, STALKER NAKED 50 2T 08-08, STALKER SPECIAL EDITION 50 2T 07-08, STORM 50 2T 94-95, STORM EURO 2 50 2T 07-07, TYPHOON 50 2T 94-97, TYPHOON X 50 2T 98-99, TYPHOON XR 50 2T 00-00

ITALJET JET SET 50 2T 02-02, TORPEDO NEW 50 2T 00-01

PIAGGIO

DIESIS 50 2T 01-01, FLY 2T 50 2T 05-07, FLY 2T 50 2T 10-11, FREE 50 2T 92-94, FREE DELIVERY 50 2T 00-01, FREE FL 50 2T 95-02, LIBERTY 50 2T 97-05, LIBERTY 2T 50 2T 06-08, LIBERTY 2T PTT EU2 50 2T 04-05, LIBERTY 2T RST 50 2T 04-04, LIBERTY 2T SPORT 50 2T 06-08, LIBERTY MOC 2T & ELLE 50 2T 09-13, NRG POWER DT 50 2T 06-15, NRG POWER DT SERIE SPECIALE 50 2T 07-08, SFERA 50 2T 91-93, SFERA MAQUILLAGE 2 50 2T 94-94, SFERA RST 50 2T 95-97, TYPHOON 50 2T 01-11, TYPHOON 2T E2 50 2T 10-12, TYPHOON 2T E3 CH 50 2T 11-11, VESPA ET2 50 2T 97-05, VESPA ET2 INIEZIONE 50 2T 97-00, VESPA LX 2T 50 2T 05-13, VESPA LX 2T TOURING & 30KM 50 2T 10-13, VESPA LXV 2T 50 2T 06-09, VESPA LXV 2T NAVY 50 2T 08-08, VESPA S 2T & COLLEGE 50 2T 07-12, ZIP 50 2T 92-93, ZIP 50 2T 95-96, ZIP BIMODALE 50 2T 94-97, ZIP FAST RIDER 50 2T 93-94, ZIP FAST RIDER RST 50 2T 96-97, ZIP RST 50 2T 96-99

RICAMBI

PT00098	Pistone completo Ø 40
PT98	Pistone completo Ø 40,5
PT0098	Pistone completo Ø 41
SG15682	Serie segmenti Ø 40

SG15683	Serie segmenti Ø 40,5
SG15684	Serie segmenti Ø 41
GR00703	Guarnizione base

cod. **KT00094** Gruppo termico Ø 40 per motore scooter 50 cc Minarelli/Yamaha Liquid Cooled senza testa



APPLICABILITÀ

APRILIA AREA 51 50 2T 98-00, GULLIVER LC 50 2T 96-98, RALLY LIQUID COOLED 50 2T 96-99, SONIC GP 50 2T 98-08, SR LIQUID COOLED 50 2T 94-96, SR RACING 50 2T 97-99, SR STEALTH 50 2T 97-00

BENELLI 491 RACING 50 2T 98-99, 491 RR 50 2T 99-01, 491 SP 50 2T 99-99, 491 SPORT 50 2T 98-99, K2 LIQUID COOLED 50 2T 98-01

BETA ARK LC 50 2T 96-08, EIKON 50 2T 99-03

ITALJET DRAGSTER 50 2T 98-02

MALAGUTI

F12 PHANTOM EURO 2 50 2T 02-02, F12 PHANTOM LC 50 2T 94-98, F12 PHANTOM LC EURO 2,3 50 2T 03-04, F12 R PHANTOM LC 50 2T 07-10, F12 RESTYLING EURO 1 50 2T 99-02, F12 RESTYLING LC EURO 2 50 2T 06-06, F15 FIRE FOX 50 2T 96-98, F15 FIRE FOX EURO 2 50 2T 02-06, F15 FIRE FOX EURO 2,3 50 2T 03-04

MBK

MACH G LC 50 2T 02-04, NITRO 50 2T 97-04, NITRO EURO 2 50 2T 03-03

YAMAHA

AEROX 50 2T 97-02, AEROX 50 2T 04-16, AEROX EURO 2 50 2T 03-03, AEROX NAKED 50 2T 13-16, AEROX R 50 2T 99-00, AEROX R 50 2T 99-99, JOG R LC 50 2T 02-15

RICAMBI

PT00097	Pistone completo Ø 40
PT97	Pistone completo Ø 40,5
PT0097	Pistone completo Ø 41
SG15682	Serie segmenti Ø 40

SG15683	Serie segmenti Ø 40,5
SG15684	Serie segmenti Ø 41
GR00716	Serie guarnizioni

cod. **KT00095** Gruppo termico Ø 40 per motore scooter 50 cc orizzontale aria Minarelli/Yamaha senza testa



APPLICABILITÀ

APRILIA GULLIVER 50 2T 95-98, RALLY 50 2T 95-03, SCARABEO 50 2T 93-05, SONIC 50 2T 98-07, SR (ORIZZONTALE) 50 2T 94-96, SR WWW 50 2T 97-01

ATALA CAROSELLO 50 2T 99-01

BENELLI 491 GT 50 2T 98-99, 491 NAKED 50 2T 02-02, 491 ST 50 2T 99-01, K2 50 2T 98-01, PEPE 50 2T 99-01, PEPE LX 50 2T 03-04

BETA ARK 50 2T 96-08, CHRONO 50 2T 95-96, QUADRA 50 2T 95-95, QUADRA 50 2T 99-01, TEMPO 50 2T 93-02, TEMPO 50 2T 95-95

KTM K50 50 2T 96-01

MACAL THUNDER 50 2T 95-96

MALAGUTI CENTRO SL 50 2T 94-98, CIAK 50 2T 99-01, CIAK EURO 2,3 50 2T 03-03, CIAK EURO2 50 2T 01-03, CIAK MASTER EURO 2 50 2T 06-06, F10 50 2T 92-00, F10 EURO 2 50 2T 02-06, F10 EURO 2,3 50 2T 03-04, F10 RESTYLING EURO 2 50 2T 06-06, F12 PHANTOM 50 2T 94-98, F12 PHANTOM EURO 2,3 50 2T 03-04, F12 RESTYLING EURO 2 50 2T 06-06, F15 FIRE FOX AIR COOLED 50 2T 05-06, YESTERDAY 50 2T 97-00

MBK

EVOLIS 50 2T 92-95, FIZZ 50 2T 94-95, FLIPPER 50 2T 98-04, FLIPPER EURO 2 50 2T 03-03, FORTE 50 2T 94-96, MACH G 50 2T 02-04, OVETTO 50 2T 97-04, OVETTO EURO 2 50 2T 02-02

MOTRON

SYNCR0 50 2T 98-00, THUNDER 50 2T 95-98

PGO

BIG MAX 50 2T 95-97

RIEJU

FIRST 50 2T 95-98, WINDY 50 2T 95-98

YAMAHA

AXIS 50 2T 95-96, BREEZE 50 2T 94-95, JOG 50 2T 92-01, JOG ER 50 2T 00-02, JOG R 50 2T 02-02, JOG R EURO2 50 2T 02-02, JOG R EURO2 50 2T 06-15, JOG Z 50 2T 95-95, NEO'S 50 2T 97-02, NEO'S 50 2T 04-16, NEO'S EASY 50 2T 13-13, NEO'S EURO 2 50 2T 02-02, WHY 50 2T 98-05, WHY EURO 2 50 2T 03-05, ZEST 50 2T 95-92

RICAMBI

PT00097	Pistone completo Ø 40
PT97	Pistone completo Ø 40,5
PT0097	Pistone completo Ø 41
SG15682	Serie segmenti Ø 40

SG15683	Serie segmenti Ø 40,5
SG15684	Serie segmenti Ø 41
GR00704	Serie guarnizioni

ATTENZIONE: QUESTI PRODOTTI SONO DESTINATI ESCLUSIVAMENTE AD USO AGONISTICO. NE È QUINDI VIETATO L'UTILIZZO SU STRADA PUBBLICA.

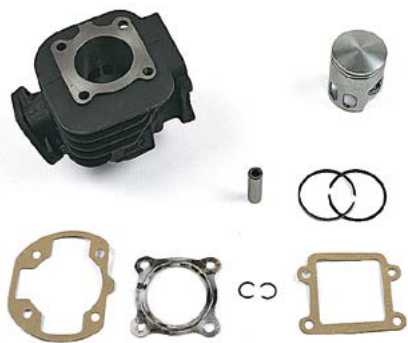

cod. **KT00096**

Gruppo termico Ø 40 per motore scooter 50 cc Minarelli/Yamaha verticale aria senza testa

APPLICABILITÀ

APRILIA AMICO 50 2T 94-94, AMICO 50 2T 96-98, AMICO GL/ GLE 50 2T 93-95, AMICO LX/SPORT/CAT 50 2T 92-93, SR (VERTICALE) 50 2T 93-93

MBK BOOSTER 50 2T 90-04, BOOSTER 50 2T 90-94, BOOSTER EURO 2 50 2T 04-04, BOOSTER NG 50 2T 95-03, BOOSTER ROCKET 50 2T 97-98, BOOSTER SPIRIT 50 2T 96-00, BOOSTER SPIRIT 50 2T 03-03, BOOSTER SPIRIT EURO2 50 2T 03-03, BOOSTER TRACK 50 2T 96-98, STUNT 50 2T 00-02

YAMAHA BW'S 50 2T 97-16, BW'S BUMP 50 2T 97-98, BW'S EASY 50 2T 13-13, BW'S NAKED 50 2T 03-04, BW'S NAKED 50 2T 09-16, BW'S NEXT GENERATION 50 2T 97-06, BW'S ORIGINAL 50 2T 99-01, BW'S ORIGINAL EURO 2 50 2T 03-03, RS SPY 50 2T 95-98, SLIDER 50 2T 00-02, ZUMA 50 2T 97-01

PT00097	Pistone completo Ø 40
PT97	Pistone completo Ø 40,5
PT0097	Pistone completo Ø 41
SG15682	Serie segmenti Ø 40

SG15683	Serie segmenti Ø 40,5
SG15684	Serie segmenti Ø 41
GR00705	Serie guarnizioni



cod. **KT00112**

Gruppo termico Ø 40 Piaggio H2O con testa

APPLICABILITÀ

APRILIA SR R 50 2T 04-09, SR R FACTORY 50 2T 04-09, SR R FACTORY Carburatore 50 2T 10-12, SR Street 50 2T 03-12

DERBI GP1 50 2T 01-03, GP1 EU2 50 2T 05-05, GP1 Open EU2 50 2T 06-09, GP1 Race EU2 50 2T 05-07

GILERA DNA 50 2T 00-02, DNA 50 2T 05-07, DNA GP Experience 50 2T 03-04, Runner 50 2T 97-00, Runner Poggiali 50 2T 02-02, Runner SP 50 2T 02-07, Runner SP 50 2T 10-12, Runner SP ST & Simoncelli 50 2T 08-09, Runner SP Special Edition 50 2T 07-07

PIAGGIO NRG 50 2T 94-96, NRG Extreme 50 2T 99-00, NRG MC3 50 2T 01-04, NRG Power DD 50 2T 05-11, NRG Power DD Serie Speciale 50 2T 07-11, NRG Power Pure Jet 50 2T-IE 04-05, NRG Power PureJet 50 2T-IE 06-11, NRG PureJet 50 2T-IE 02-04, NRG PureJet 50 2T-IE 10-10, NRG RST MC2 50 2T 96-98, NTT 50 2T 95-96, Quartz 50 2T 92-96, Zip 2T 50 2T 08-12, Zip LC 50 2T 00-04, Zip Sp 50 2T 96-04, Zip Sp Euro 2 50 2T 06-12

RICAMBI

PT00098	Pistone Ø 40
PT98	Pistone Ø 40,5
PT0098	Pistone Ø 41
SG15682	Serie segmenti Ø 40
SG15683	Serie segmenti Ø 40,5

SG15684	Serie segmenti Ø 41
GR00734	Serie guarnizioni
TS00180	Testa Ø 40
AA00769	Raccordo in alluminio per testa



cod. **KT00115**

Gruppo termico Ø 40 per Derbi Senda con testa

APPLICABILITÀ

DERBI BULTACO LOBITO 50 2T 98-01, GPR NUDE 50 2T 04-05, GPR R 50 2T 97-00, GPR RACING 50 2T 04-05, GPR REPLICCA 50 2T 99-01, GPR REPLICCA RACING 50 2T 02-03, GPR REPLICCA RACING EU2 50 2T 05-05, SENDA BLACK EDITION 50 2T 03-03, SENDA R 50 2T 99-01, SENDA R DRD BLACK DEVIL 2A EDIZIONE 50 2T 03-03, SENDA R DRD EU1 EU1R 50 2T 02-02, SENDA R DRD RACING 50 2T 04-05, SENDA R DRD RACING LTD 50 2T 05-05, SENDA R RACER 50 2T 03-03, SENDA R X-RACE 50 2T 04-05, SENDA R X-TREME 50 2T 03-03, SENDA R X-TREME 50 2T 05-05, SENDA R X-TREME EU2 50 2T 04-04, SENDA SM 50 2T 00-01, SENDA SM DRD EDITION BLACK 50 2T 05-05, SENDA SM DRD EU1 EU1R 50 2T 02-03, SENDA SM DRD RACING 50 2T 04-05, SENDA SM DRD RACING LTD 50 2T 05-05, SENDA SM X-RACE 50 2T 04-05, SENDA SM X-TREME 50 2T 02-03, SENDA SM X-TREME EU2 50 2T 04-04, SENDA SM X-TREME EU2 2A EDIZIONE 50 2T 05-05

GILERA GSM 50 2T 01-01, RCR 50 2T 03-03, SMT 50 2T 03-03

RICAMBI

PT00154	Pistone completo Ø 40
PT154	Pistone completo Ø 40,28
SG15852	Serie segmenti Ø 40
SG15854	Serie segmenti Ø 40,28

GR00725	Nuova serie guarnizioni
GR00720	Serie guarnizioni
TS00181	Testa

ATTENZIONE: QUESTI PRODOTTI SONO DESTINATI ESCLUSIVAMENTE AD USO AGONISTICO. NE È QUINDI VIETATO L'UTILIZZO SU STRADA PUBBLICA.



◀ cod. **KT00119**
Gruppo termico Ø 40 per Peugeot H20 con testa

APPLICABILITÀ

PEUGEOT SPEEDFIGHT 50 2T 97-04, SPEEDFIGHT LC 50 2T 97-04, X-FIGHT LC 50 2T 00-02

RICAMBI

PT00155	Pistone Ø 39,88
PT155	Pistone Ø 40,28
SG15853	Serie segmenti Ø 39,88
SG15856	Serie segmenti Ø 40,28

GR00714	Serie guarnizioni
GR00721	Serie guarnizioni Ø 39,88
TS00185	Testa Ø 40



◀ cod. **KT00123**
Gruppo termico Ø 40 Peugeot Buxy EU-2 senza testa

APPLICABILITÀ

PEUGEOT BUXY 50 2T 90-02, BUXY RS 50 2T 90-02, ELYSEO 50 2T 90-02, LOOXOR 50 2T 90-02, METAL X 50 2T 90-02, SPEEDAKE 50 2T 90-02, SPEEDFIGHT 50 2T 97-04, SQUAB 50 2T 90-02, SV GEO 50 2T 90-02, TREKKER 50 2T 90-02, VIVACITY 50 2T 90-02, X-FIGHT 50 2T 00-02, X-FIGHT LC 50 2T 00-02, ZENITH 50 2T 90-02

RICAMBI

PT00099	Pistone Ø 40
PT99	Pistone Ø 40,5
SG15682	Serie segmenti Ø 40

SG15683	Serie segmenti Ø 40,5
SG15684	Serie segmenti Ø 41
GR00718	Serie guarnizioni



◀ cod. **KT00129**
Gruppo termico Ø 40 Keeway Focus senza testa

APPLICABILITÀ

BENELLI PEPE 50 2T 10-10, PEPE LX 50 2T 07-09, PEPE OLD 50 2T 07-09, PEPE OLD 50 2T 11-11, QUATTRONEX 50 2T 08-11

CPI ARAGON 50 2T 03-03, HUSSAR 50 2T 03-03, OLIVER 50 2T 03-03, POP CORN 50 2T 03-03

EXPLORER CRACKER 50 2T 03-03

KEEWAY F-ACT 50 2T 07-08, FLASH 50 2T 07-08, FOCUS 50 2T 06-06, GOCCIA 50 2T 09-09, HURRICANE 50 2T 06-08, MATRIX 50 2T 06-08, PIXEL EURO 2 50 2T 09-12, RY8 50 2T 08-08

MALAGUTI F10 AC WAP 50 2T 08-08, F12 R PHANTOM AC 50 2T 07-08

RICAMBI

PT00107	Pistone Ø 40
PT107	Pistone Ø 40,5
SG15682	Serie segmenti Ø 40

SG15683	Serie segmenti Ø 40,5
GR00733	Serie guarnizioni

ATTENZIONE: QUESTI PRODOTTI SONO DESTINATI ESCLUSIVAMENTE AD USO AGONISTICO. NE È QUINDI VIETATO L'UTILIZZO SU STRADA PUBBLICA.



◀ cod. **KT00098**
Gruppo termico Ø 40,3 (AM 345/6) E EU1 con testa

APPLICABILITÀ

APRILIA	CLASSIC 50 2T 92-99, EUROPA 50 2T 91-92, MX 50 2T 04-04, MX MOTARD 50 2T 95-03, PEGASO 50 2T 92-94, RS 50 2T 91-05, RX 50 2T 03-04, RX 3-5 MARCE 50 2T 91-94, RX ENDURO 50 2T 95-03, RX RACING 50 2T 03-06, TUONO 50 2T 03-04
BETA	RR 2T 50 EU4 50 2T 18-20, RR 50 RACING EU4 50 2T 18-20, RR ALU 50 2T 08-12, RR ENDURO 50 2T 06-17, RR MOTARD 50 2T 06-17
CH HUSQUARNA	SM 50 2T 00-10, WR 50 2T 00-10, WSM 50 2T 00-10
CMC	ENDURO 50 2T 11-11, MOTARD 50 2T 11-11
FANTIC	CABALLERO MOTARD 50 2T 06-10, CABALLERO REGOLARITÀ 50 2T 06-10, ENDURO COMPETITION EU4 50 2T 18-20, ENDURO PERFORMANCE EU4 50 2T 18-20, MOTARD COMPETITION EU4 50 2T 18-20, MOTARD PERFORMANCE EU4 50 2T 18-20
HM	BAJA, DERAPAGE BASIC 50 2T 10-11, CMC 50 2T 10-11, CRE BAJA RR, DERAPAGE RR 50 2T 07-11, CRE BAJA, DERAPAGE 50 2T 07-11, CRE SIX COMPETITION 50 2T 10-11, CRE SIX, BAJA, DERAPAGE 50 2T 95-06, CRE SIX, DERAPAGE COMPETITION 50 2T 07-09, DERAPAGE COMPETITION 50 2T 10-11
MBK	X LIMIT 50 2T 03-04, X POWER 50 2T 03-04
MALAGUTI	CNK DRAGON 50 2T 05-07, FIFTY EVOLUTION 50 2T 90-93, XSM 50 2T 03-03, XTM 50 2T 03-03

MINARELLI	MOTORE AM 3-4-5 50 2T 91-95, MOTORE AM 6 1° SERIE 50 2T 96-11, MOTORE AM 6 2° SERIE 50 2T 12-18
MOTORHISPANIA	FURIA 50 2T 97-00, FURIA MAX 50 2T 10-12, RX 50 2T 09-12, RX R 50 2T 09-12
PEUGEOT	SUPERMOTARD 50 2T 90-02, XP6 TRAIL S/AVV. ELETTRICO 50 2T 90-02, XR6 RACING CAT. C/AVV.ELETT. 50 2T 90-02
RIEJU	MRT 50 2T 09-12, MRT 50 EU4 50 2T 18-20, MRT PRO 50 2T 09-12, MRT PRO EU4 50 2T 18-20, MRT PRO REPLICA EU4 50 2T 18-20, MRT PRO REPLICA SM EU4 50 2T 18-20, MRT PRO SM 50 2T 09-12, MRT PRO SM EU4 50 2T 18-20, MRT SM 50 2T 09-12, MRT SM EU4 50 2T 18-20, MRT TROPHY EU4 50 2T 18-20, MRX 50 2T 01-04, MRX PRO 50 2T 01-04, RR 50 2T 05-06, RS1 50 2T 98-01, RS2 MATRIX 50 2T 05-06, RS2 MATRIX PRO 50 2T 05-06, RS2 NAKED 50 2T 04-05, RS3 EU4 50 2T 18-20, RS3 NKD EU4 50 2T 18-20, SMX E.S./K.S. 50 2T 01-01, SMX PRO E.S./K.S. 50 2T 03-03, SPIKE 50 2T 98-01
SHERCO	FACTORY SE-R EU4 50 2T 18-20, FACTORY SE-RS EU4 50 2T 18-20, FACTORY SILVER SM-R EU4 50 2T 18-20, FACTORY SILVER SM-RS EU4 50 2T 18-20, FACTORY SM-R EU4 50 2T 18-20, FACTORY SM-RS EU4 50 2T 18-20, HRD ENDURO 50 2T 09-13, HRD MOTARD 50 2T 09-13
VENT	BAJA 50 2T 18-20, BAJA RR 50 2T 18-20, DERAPAGE 50 2T 18-20, DERAPAGE RR 50 2T 18-20
YAMAHA	DT R 50 2T 03-11, DT RSM 50 2T 03-05, DT X 50 2T 06-11, TZR 50 2T 03-08, TZR 50 2T 10-11, TZR RR 50 2T 05-05

RICAMBI

PT00104	Pistone completo Ø 40,3
PT104	Pistone completo Ø 40,6
PT0104	Pistone completo Ø 40,8
SG15706	Serie segmenti Ø 40,3

SG15707	Serie segmenti Ø 40,6
SG15708	Serie segmenti Ø 40,8
GR00715	Serie guarnizioni
TS00179	Testa



◀ cod. **KT00066**
Gruppo termico Ø 43 spinotto 12 Ciao-Si serie Evolution

APPLICABILITÀ

PIAGGIO	BOSS 50 2T 88-89, BOXER 50 2T 70-83, BRAVO 3 50 2T 87-90, BRAVO ERRE 2 50 2T 75-81, CIAO 50 2T 80-88, CIAO EU1 50 2T 99-01, CIAO EU2 50 2T 02-04, CIAO MIX TEEN 50 2T 96-01, CIAO TRE 50 2T 71-99, ECO 50 2T 79-89, GRILLO 50 2T 89-93, SI 50 2T 79-88, SI FL2 50 2T 91-97, SI MIX 50 2T 96-99
----------------	--

RICAMBI

PT00092	Pistone completo Ø 43
SG15585	Serie segmenti Ø 43

GR00698	Guarnizione base
----------------	------------------



◀ cod. **KT00067**
Gruppo termico Ø 43 spinotto 10 Ciao-Si

APPLICABILITÀ

PIAGGIO	BOSS 50 2T 88-89, BOXER 50 2T 70-83, BRAVO 3 50 2T 87-90, BRAVO ERRE 2 50 2T 75-81, CIAO 50 2T 80-88, CIAO EU1 50 2T 99-01, CIAO EU2 50 2T 02-04, CIAO MIX TEEN 50 2T 96-01, CIAO TRE 50 2T 71-99, ECO 50 2T 79-89, GRILLO 50 2T 89-93, SI 50 2T 79-88, SI FL2 50 2T 91-97, SI MIX 50 2T 96-99
----------------	--

RICAMBI

PT00094	Pistone completo Ø 43
SG15585	Serie segmenti Ø 43

GR00698	Guarnizione base
----------------	------------------

ATTENZIONE: QUESTI PRODOTTI SONO DESTINATI ESCLUSIVAMENTE AD USO AGONISTICO. NE È QUINDI VIETATO L'UTILIZZO SU STRADA PUBBLICA.



◀ cod. **KT00048**
Gruppo termico Ø 46 Honda Camino PX

APPLICABILITÀ

HONDA CAMINO PX 50 2T 70-80

RICAMBI

PT00079	Pistone completo Ø 46
SG15031	Serie segmenti Ø 46

GR00683	Serie guarnizioni
---------	-------------------



◀ cod. **KT00057**
Gruppo termico Ø 46 Suzuki Address senza testa

APPLICABILITÀ

APRILIA HABANA-MOJITO CUSTOM 50 2T 99-03, HABANA-MOJITO RETRO' 50 2T 99-03
ATALA HACKER 50 2T 95-00, VAMOS 50 2T 93-95
BENELLI 491 ST MORINI 50 2T 03-03, NAKED MORINI 50 2T 03-04
HYOSUNG SD SENSE EU1 50 2T 00-01, SD SENSE EU2 50 2T 05-05, SF B RALLY 50 2T 04-08, SF FAST 50 2T 00-00, SF FAST EU2 50 2T 01-03, SF R RALLY 50 2T 04-08

ITALJET FORMULA 50 2T 94-97, VELOCIFERO 50 2T 98-02

MALAGUTI CROSSER CR1 50 2T 95-98

SUZUKI AH Address 50 2T 92-95, AJ ZZ 50 2T 95-97, AP 50 2T 94-97, Street Magic 50 2T 98-98

RICAMBI

PT00089	Pistone completo Ø 46
PT89	Pistone completo Ø 46,5
SG15282	Serie segmenti Ø 46

SG15283	Serie segmenti Ø 46,5
GR00731	Serie guarnizioni



◀ cod. **KT00073**
Gruppo termico Ø 46 Wallaroo

APPLICABILITÀ

HONDA WALLAROO 50 2T 90-01

RICAMBI

PT00072	Pistone completo Ø 46
SG15168	Serie segmenti Ø 46

GR06347	Guarnizione base
---------	------------------

ATTENZIONE: QUESTI PRODOTTI SONO DESTINATI ESCLUSIVAMENTE AD USO AGONISTICO. NE È QUINDI VIETATO L'UTILIZZO SU STRADA PUBBLICA.



cod. **KT00011**

Gruppo termico Vespa Ø 47 3 travasi

Cilindro in ghisa Minacrom con 3 travasi | Cilindrata 74,60 cc - Corsa mm 43 - Rapp. Comp. 1:10,7 | Completo di testa

APPLICABILITÀ

PIAGGIO Vespa 50 2T 67-82, Vespa FL 50 2T 90-90, Vespa FL2 AUTOMATICA 50 2T 90-91, Vespa FL2 HP 50 2T 91-97, Vespa N 50 2T 89-90, Vespa PK 50 2T 82-84, Vespa PK AUTOMATICA 50 2T 84-89, Vespa PK XL 50 2T 85-88, Vespa PK XL PLURIMATIC 50 2T 85-90, Vespa PK XL RUSH 50 2T 88-89

RICAMBI

PT00058	Pistone completo Ø 47
PT58	Pistone completo Ø 47,4
SG15036	Serie segmenti Ø 47
SG15038	Serie segmenti Ø 47,4

SG15040	Serie segmenti Ø 47,8
GR00727	Serie guarnizioni
TS00151	Testa



cod. **KT00013**

Gruppo termico Vespa Ø 47 6 travasi

Cilindro in ghisa Minacrom con 6 travasi | Cilindrata 74,60 cc - Corsa mm 43 - Rapp. Comp. 1:10,7 | Completo di testa

APPLICABILITÀ

PIAGGIO APE 50 2T 09-17, APE FL - FL2 50 2T 89-95, APE FL3 EUROPA 50 2T 96-99, APE MIX 2T 50 2T 98-08, APE P 50 2T 80-85, APE RST MIX 50 2T 99-03, APE TM P 50 2T 85-89, VESPA FL 50 2T 90-90, VESPA FL2 HP 50 2T 91-97, VESPA N 50 2T 89-90, VESPA PK 50 2T 82-84, VESPA PK XL 50 2T 85-88, VESPA PK XL RUSH 50 2T 88-89, VESPA SPECIAL-L-R 50 2T 67-82

RICAMBI

PT00061	Pistone completo Ø 47
PT61	Pistone Ø 47,4
SG15036	Serie segmenti Ø 47
SG15038	Serie segmenti Ø 47,4

SG15040	Serie segmenti Ø 47,8
GR00727	Serie guarnizioni
TS00151	Testa



cod. **KT00049**

Gruppo termico Ø 47 10 luci

Cilindro in ghisa Minacrom con 10 travasi | Cilindrata 74,60 cc - Corsa mm 43 - Rapp. Comp. 1:10,7 | Completo di testa

APPLICABILITÀ

PIAGGIO APE 50 2T 09-17, APE FL - FL2 50 2T 89-95, APE FL3 EUROPA 50 2T 96-99, APE MIX 2T 50 2T 98-08, APE P 50 2T 80-85, APE RST MIX 50 2T 99-03, APE TM P 50 2T 85-89, VESPA FL 50 2T 90-90, VESPA FL2 HP 50 2T 91-97, VESPA N 50 2T 89-90, VESPA PK 50 2T 82-84, VESPA PK XL 50 2T 85-88, VESPA PK XL RUSH 50 2T 88-89, VESPA SPECIAL-L-R 50 2T 67-82

RICAMBI

PT00080	Pistone completo Ø 47
PT80	Pistone completo Ø 47,4
PT0080	Pistone completo Ø 47,8
SG15036	Serie segmenti Ø 47

SG15038	Serie segmenti Ø 47,4
SG15040	Serie segmenti Ø 47,8
GR00727	Serie guarnizioni
TS00151	Testa

ATTENZIONE: QUESTI PRODOTTI SONO DESTINATI ESCLUSIVAMENTE AD USO AGONISTICO. NE È QUINDI VIETATO L'UTILIZZO SU STRADA PUBBLICA.



◀ **cod. KT00058**
Gruppo termico Ø 47 Peugeot SV-Geo

APPLICABILITÀ

PEUGEOT BUXY 50 2T 90-02, BUXY RS 50 2T 90-02, ELYSEO 50 2T 90-02, LOOKOR 50 2T 90-02, METAL X 50 2T 90-02, SPEEDAKE 50 2T 90-02, SPEEDFIGHT 50 2T 97-04, SQUAB 50 2T 90-02, SV GEO 50 2T 90-02, TREKKER 50 2T 90-02, VIVACITY 50 2T 90-02, X-FIGHT 50 2T 00-02, X-FIGHT LC 50 2T 00-02, ZENITH 50 2T 90-02

RICAMBI

PT00090	Pistone completo Ø 47
PT90	Pistone completo Ø 47,4
PT0090	Pistone completo Ø 47,8
SG15036	Serie segmenti Ø 47

SG15038	Serie segmenti Ø 47,4
SG15040	Serie segmenti Ø 47,8
GR00717	Serie guarnizioni



◀ **cod. KT00087**
Gruppo termico Ø 47 per motore scooter 50 cc Minarelli/Yamaha orizzontale Evolution

APPLICABILITÀ

APRILIA GULLIVER 50 2T 95-98, RALLY 50 2T 95-03, SCARABEO 50 2T 93-05, SONIC 50 2T 98-07, SR (ORIZZONTALE) 50 2T 94-96, SR WWW 50 2T 97-01

ATALA CAROSELLO 50 2T 99-01

BENELLI 491 GT 50 2T 98-99, 491 NAKED 50 2T 02-02, 491 ST 50 2T 99-01, K2 50 2T 98-01, PEPE 50 2T 99-01, PEPE LX 50 2T 03-04

BETA ARK 50 2T 96-08, CHRONO 50 2T 95-96, QUADRA 50 2T 95-95, QUADRA 50 2T 99-01, TEMPO 50 2T 93-02, TEMPO 50 2T 95-95

KTM K50 50 2T 96-01

MACAL THUNDER 50 2T 95-96

MALAGUTI CENTRO SL 50 2T 94-98, CIAK 50 2T 99-01, CIAK EURO 2 2,3 50 2T 03-03, CIAK EURO2 50 2T 01-03, CIAK MASTER EURO 2 50 2T 06-06, F10 50 2T 92-00, F10 EURO 2 50 2T 02-06, F10 EURO 2 2,3 50 2T 03-04, F10 RESTYLING EURO 2 50 2T 06-06, F12 PHANTOM 50 2T 94-98, F12 PHANTOM EURO 2 2,3 50 2T 03-04, F12 RESTYLING EURO 2 50 2T 06-06, F15 FIRE FOX AIR COOLED 50 2T 05-06, YESTERDAY 50 2T 97-00

MBK EVOLIS 50 2T 92-95, FIZZ 50 2T 94-95, FLIPPER 50 2T 98-04, FLIPPER EURO 2 50 2T 03-03, FORTE 50 2T 94-96, MACH G 50 2T 02-04, OVETTO 50 2T 97-04, OVETTO EURO 2 50 2T 02-02

MOTRON SYNCRO 50 2T 98-00, THUNDER 50 2T 95-98

PGO BIG MAX 50 2T 95-97

RIEJU FIRST 50 2T 95-98, WINDY 50 2T 95-98

YAMAHA AXIS 50 2T 95-96, BREEZE 50 2T 94-95, JOG 50 2T 92-01, JOG ER 50 2T 00-02, JOG R 50 2T 02-02, JOG R EURO2 50 2T 02-02, JOG R EURO2 50 2T 06-15, JOG Z 50 2T 95-95, NEO'S 50 2T 97-02, NEO'S 50 2T 04-16, NEO'S EASY 50 2T 13-13, NEO'S EURO 2 50 2T 02-02, WHY 50 2T 98-05, WHY EURO 2 50 2T 03-05, ZEST 50 2T 95-92

RICAMBI

PT00102	Pistone completo Ø 47
PT102	Pistone completo Ø 47,4
SG15284	Serie segmenti Ø 47

SG15691	Serie segmenti Ø 47,4
GR00702	Serie guarnizioni
TS00170	Testa

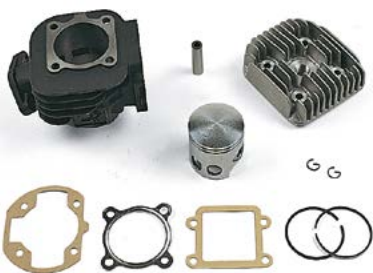

◀ **cod. KT00088**
Gruppo termico Ø 47 per motore scooter 50 cc Minarelli/Yamaha tipo verticale

APPLICABILITÀ

APRILIA AMICO 50 2T 94-94, AMICO 50 2T 96-98, AMICO GL/ GLE 50 2T 93-95, AMICO LX/SPORT/CAT 50 2T 92-93, SR (VERTICALE) 50 2T 93-93

MBK BOOSTER 50 2T 90-04, BOOSTER 50 2T 90-94, BOOSTER EURO 2 50 2T 04-04, BOOSTER NG 50 2T 95-03, BOOSTER ROCKET 50 2T 97-98, BOOSTER SPIRIT 50 2T 96-00, BOOSTER SPIRIT 50 2T 03-03, BOOSTER SPIRIT EURO2 50 2T 03-03, BOOSTER TRACK 50 2T 96-98, STUNT 50 2T 00-02

YAMAHA BW'S 50 2T 97-16, BW'S BUMP 50 2T 97-98, BW'S EASY 50 2T 13-13, BW'S NAKED 50 2T 03-04, BW'S NAKED 50 2T 09-16, BW'S NEXT GENERATION 50 2T 97-00, BW'S NEXT GENERATION 50 2T 99-06, BW'S ORIGINAL 50 2T 99-00, BW'S ORIGINAL 50 2T 99-02, BW'S ORIGINAL EURO 2 50 2T 03-03, RS SPY 50 2T 95-98, SLIDER 50 2T 00-02, ZUMA 50 2T 97-01

RICAMBI

PT00102	Pistone completo Ø 47
PT102	Pistone completo Ø 47,4
SG15284	Serie segmenti Ø 47

SG15691	Serie segmenti Ø 47,4
GR00701	Serie guarnizioni
TS00165	Testa

ATTENZIONE: QUESTI PRODOTTI SONO DESTINATI ESCLUSIVAMENTE AD USO AGONISTICO. NE È QUINDI VIETATO L'UTILIZZO SU STRADA PUBBLICA.



◀ cod. **KT00090**
Gruppo termico Ø 47 per Honda Bali

APPLICABILITÀ

HONDA BALI 50 2T 93-99, SFX / SXR 50 2T 95-01, SGX SKY 50 2T 97-04, SH NEW 50 2T 96-01, X8R S 50 2T 98-01, X8R X 50 2T 98-01

RICAMBI

PT00103	Pistone completo Ø 47
PT103	Pistone completo Ø 47,4
SG15695	Serie segmenti Ø 47

SG15696	Serie segmenti Ø 47,4
GR00709	Serie guarnizioni



◀ cod. **KT00109**
Gruppo termico Ø 47 per motore scooter 50 cc Minarelli/Yamaha Liquid Cooled

APPLICABILITÀ

APRILIA AREA 51 50 2T 98-00, GULLIVER LC 50 2T 96-98, RALLY LIQUID COOLED 50 2T 96-99, SONIC GP 50 2T 98-08, SR LIQUID COOLED 50 2T 94-96, SR RACING 50 2T 97-99, SR STEALTH 50 2T 97-00

BENELLI 491 RACING 50 2T 98-99, 491 RR 50 2T 99-01, 491 SP 50 2T 99-99, 491 SPORT 50 2T 98-99, K2 LIQUID COOLED 50 2T 98-01

BETA ARK LC 50 2T 96-08, EIKON 50 2T 99-03

ITALJET DRAGSTER 50 2T 98-02

MALAGUTI F12 PHANTOM LC 50 2T 94-98, F12 R PHANTOM LC 50 2T 07-10, F15 FIRE FOX 50 2T 96-98, F15 FIRE FOX EURO 2 50 2T 02-06, F15 FIRE FOX EURO 2 2,3 50 2T 03-04

MBK MACH G LC 50 2T 02-04, NITRO 50 2T 97-04, NITRO EURO 2 50 2T 03-03

YAMAHA AEROX 50 2T 97-02, AEROX 50 2T 04-16, AEROX EURO 2 50 2T 03-03, AEROX NAKED 50 2T 13-16, AEROX R 50 2T 99-00, AEROX R 50 2T 99-99, JOG R LC 50 2T 02-15

RICAMBI

PT00102	Pistone Ø 47
PT102	Pistone Ø 47,4
SG15284	Serie segmenti Ø 47
SG15691	Serie segmenti Ø 47,4

GR00711	Rid. ermetica con guarnizione
GR00713	Serie guarnizioni
TS00175	Testa Ø 47



◀ cod. **KT00116**
Gruppo termico Ø 47 Peugeot Liquid Cooled con testa

APPLICABILITÀ

PEUGEOT SPEEDFIGHT 50 2T 97-04, SPEEDFIGHT LC 50 2T 97-04, X-FIGHT LC 50 2T 00-02

RICAMBI

PT00090	Pistone Ø 47
PT90	Pistone Ø 47,4
PT0090	Pistone Ø 47,8
SG15036	Serie segmenti Ø 47
SG15038	Serie segmenti Ø 47,4

SG15040	Serie segmenti Ø 47,8
GR00714	Serie guarnizioni
GR00721	Serie guarnizioni
TS00184	Testa



◀ **cod. KT00128**
Gruppo termico Ø 47 Keeway Focus

APPLICABILITÀ

BENELLI PEPE 50 2T 10-10, PEPE LX 50 2T 07-09, PEPE OLD 50 2T 07-09, PEPE OLD 50 2T 11-11, QUATTRONEX 50 2T 08-11

CPI ARAGON 50 2T 03-03, HUSSAR 50 2T 03-03, OLIVER 50 2T 03-03, POP CORN 50 2T 03-03

EXPLORER CRACKER 50 2T 03-03

KEEWAY F-ACT 50 2T 07-08, FLASH 50 2T 07-08, FOCUS 50 2T 06-06, GOCCIA 50 2T 09-09, HURRICANE 50 2T 06-08, MATRIX 50 2T 06-08, PIXEL EURO 2 50 2T 09-12, RY8 50 2T 08-08

MALAGUTI F10 AC WAP 50 2T 08-08, F12 R PHANTOM AC 50 2T 07-08

RICAMBI

PT00106	Pistone Ø 47
PT106	Pistone Ø 47,4
SG15284	Serie segmenti Ø 47
SG15691	Serie segmenti Ø 47,4

GR00732	Serie guarnizioni
TS00170	Testa
SP00726	Spinotto



◀ **cod. KT00086**
Gruppo termico Ø 48 Sfera - Zip Evolution

APPLICABILITÀ

APRILIA MOJITO CUSTOM 2T MOTORE PIAGGIO 50 2T 04-10, SCARABEO 2T EU2 MOTORE PIAGGIO 50 2T 10-12, SCARABEO 2T NET 50 2T 09-10, SCARABEO STREET 50 2T 05-06, SCARABEO STREET 2T RESTYLING 50 2T 06-09, SPORT CITY ONE 2T 50 2T 08-11

DERBI ATLANTIS 2T 50 2T 10-10, ATLANTIS 2T EU2 50 2T 07-09, ATLANTIS O2 50 2T 02-02, ATLANTIS O2 BULLET 50 2T 03-05, ATLANTIS O2 CITY 50 2T 04-06, ATLANTIS O2 RED BULLET 50 2T 03-03, ATLANTIS O2 TWO CHIC 50 2T 05-05, BOULEVARD 2T 50 2T 09-14, SONAR 2T 50 2T 09-09

GILERA EASY MOVING 50 2T 95-96, ICE 50 2T 01-05, STALKER 50 2T 97-11, STALKER NAKED 50 2T 08-08, STALKER SPECIAL EDITION 50 2T 07-08, STORM 50 2T 94-95, STORM EURO 2 50 2T 07-07, TYPHOON 50 2T 94-97, TYPHOON X 50 2T 98-99, TYPHOON XR 50 2T 00-00

ITALJET JET SET 50 2T 02-02, TORPEDO NEW 50 2T 00-01

PIAGGIO DIESIS 50 2T 01-01, FLY 2T 50 2T 05-07, FLY 2T 50 2T 10-11, FREE 50 2T 92-94, FREE DELIVERY 50 2T 00-01, FREE FL 50 2T 95-02, LIBERTY 50 2T 97-05, LIBERTY 2T 50 2T 06-08, LIBERTY 2T PTT EU2 50 2T 04-05, LIBERTY 2T RST 50 2T 04-04, LIBERTY 2T SPORT 50 2T 06-08, LIBERTY MOC 2T & ELLE 50 2T 09-13, NRG POWER DT 50 2T 06-15, NRG POWER DT SERIE SPECIALE 50 2T 07-08, SFERA 50 2T 91-93, SFERA MAQUILLAGE 2 50 2T 94-94, SFERA RST 50 2T 95-97, TYPHOON 50 2T 01-11, TYPHOON 2T E2 50 2T 10-12, TYPHOON 2T E3 CH 50 2T 11-11, VESPA ET2 50 2T 97-05, VESPA ET2 INIEZIONE 50 2T 97-00, VESPA LX 2T 50 2T 05-13, VESPA LX 2T TOURING & 30KM 50 2T 10-13, VESPA LXV 2T 50 2T 06-09, VESPA LXV 2T NAVY 50 2T 08-08, VESPA S 2T & COLLEGE 50 2T 07-12, ZIP 50 2T 92-93, ZIP 50 2T 95-96, ZIP BIMODALE 50 2T 94-97, ZIP FAST RIDER 50 2T 93-94, ZIP FAST RIDER RST 50 2T 96-97, ZIP RST 50 2T 96-99

RICAMBI

PT00100	Pistone completo Ø 48
PT100	Pistone completo Ø 48,5
PT0100	Pistone completo Ø 49
SG15688	Serie segmenti Ø 48

SG15689	Serie segmenti Ø 48,5
GR06411	Serie guarnizioni
TS00166	Testa



◀ **cod. KT00091**
Gruppo termico Ø 48 Piaggio Liquid Cooled Evolution

APPLICABILITÀ

APRILIA SR (motore Piaggio) '03 - '05, SR R Factory '04 - '07

GILERA Runner, Runner SP

PIAGGIO NRG mc2, NTT, Zip SP

RICAMBI

PT00100	Pistone Ø 48
PT100	Pistone Ø 48,5
PT0100	Pistone Ø 49
SG15688	Serie segmenti Ø 48

SG15689	Serie segmenti Ø 48,5
SG15690	Serie segmenti Ø 49
GR00708	Serie guarnizioni
TS00178	Testa

ATTENZIONE: QUESTI PRODOTTI SONO DESTINATI ESCLUSIVAMENTE AD USO AGONISTICO. NE È QUINDI VIETATO L'UTILIZZO SU STRADA PUBBLICA.



cod. **KT00097**

Gruppo termico Ø 48 per Piaggio Liquid Cooled con raccordo

APPLICABILITÀ

APRILIA	SR MOTARD 50 2T 12-14, SR R 50 2T 04-09, SR R FACTORY CARBURATORE 50 2T 10-14, SR R FACTORY IE 50 2T 10-14, SR STREET CARBURATORE 50 2T 03-12
DERBI	GP1 50 2T 01-03, GP1 EU 2 50 2T 05-05, GP1 OPEN EU2 50 2T 06-09, GP1 RACE EU2 50 2T 05-07
GILERA	DNA 50 2T 00-02, DNA 50 2T 05-07, DNA GP EXPERIENCE 50 2T 03-04, RUNNER 50 2T 97-00, RUNNER POGGIALLI 50 2T 02-02, RUNNER SP 50 2T 02-07, RUNNER SP 50 2T 10-12, RUNNER SP SPECIAL EDITION 50 2T 07-07, RUNNER SP ST & SIMONCELLI 50 2T 08-09

PIAGGIO	NRG 50 2T 94-96, NRG EXTREME LC 50 2T 99-00, NRG MC3 50 2T 01-04, NRG POWER DD 50 2T 05-17, NRG POWER DD SERIE SPECIALE 50 2T 07-12, NRG POWER PUREJET 50 2T-IE 04-11, NRG PUREJET 50 2T-IE 02-04, NRG PUREJET 50 2T-IE 10-10, NRG RST MC2 50 2T 96-98, NTT 50 2T 95-96, QUARTZ 50 2T 92-96, ZIP 2T 50 2T 08-13, ZIP LC 50 2T 00-04, ZIP SP 50 2T 96-04, ZIP SP EURO 2 50 2T 06-13
----------------	--

RICAMBI

PT00100	Pistone Ø 48
PT100	Pistone Ø 48,5
PT0100	Pistone Ø 49
SG15688	Serie segmenti Ø 48

SG15689	Serie segmenti Ø 48,5
GR00708	Serie guarnizioni
TS00178	Testa
AA00769	Raccordo per testa

cod. **KT00114**

Gruppo termico Ø 49 per motore Minarelli AM con testa



APPLICABILITÀ

APRILIA	CLASSIC 50 2T 92-99, EUROPA 50 2T 91-92, MX 50 2T 04-04, MX MOTARD 50 2T 95-03, PEGASO 50 2T 92-94, RS 50 2T 91-05, RX 50 2T 03-04, RX 3-5 MARCE 50 2T 91-94, RX ENDURO 50 2T 95-03, RX RACING 50 2T 03-06, TUONO 50 2T 03-04
BETA	RR 2T 50 EU4 50 2T 18-20, RR 50 RACING EU4 50 2T 18-20, RR ALU 50 2T 08-12, RR ENDURO 50 2T 06-17, RR MOTARD 50 2T 06-17
CH	SM 50 2T 00-10, WR 50 2T 00-10, WSM 50 2T 00-10
HUSQUARNA	ENDURO 50 2T 11-11, MOTARD 50 2T 11-11
CMC	CABALLERO MOTARD 50 2T 06-10, CABALLERO REGOLARITÀ 50 2T 06-10, ENDURO COMPETITION EU4 50 2T 18-20, ENDURO PERFORMANCE EU4 50 2T 18-20, MOTARD COMPETITION EU4 50 2T 18-20, MOTARD PERFORMANCE EU4 50 2T 18-20
FANTIC	BAJA, DERAPAGE BASIC 50 2T 10-11, CMC 50 2T 10-11, CRE BAJA RR, DERAPAGE RR 50 2T 07-11, CRE BAJA, DERAPAGE 50 2T 07-11, CRE SIX COMPETITION 50 2T 10-11, CRE SIX, BAJA, DERAPAGE 50 2T 95-06, CRE SIX, DERAPAGE COMPETITION 50 2T 07-09, DERAPAGE COMPETITION 50 2T 10-11
HM	BAJA, DERAPAGE BASIC 50 2T 10-11, CMC 50 2T 10-11, CRE BAJA RR, DERAPAGE RR 50 2T 07-11, CRE BAJA, DERAPAGE 50 2T 07-11, CRE SIX COMPETITION 50 2T 10-11, CRE SIX, BAJA, DERAPAGE 50 2T 95-06, CRE SIX, DERAPAGE COMPETITION 50 2T 07-09, DERAPAGE COMPETITION 50 2T 10-11
MBK	X LIMIT 50 2T 03-04, X POWER 50 2T 03-04
MALAGUTI	CNK DRAGON 50 2T 05-07, FIFTY EVOLUTION 50 2T 90-93, XSM 50 2T 03-03, XTM 50 2T 03-03

MINARELLI	MOTORE AM 3-4-5 50 2T 91-95, MOTORE AM 6 1° SERIE 50 2T 96-11, MOTORE AM 6 2° SERIE 50 2T 12-18
MOTORHISPANIA	FURIA 50 2T 97-00, FURIA MAX 50 2T 10-12, RX 50 2T 09-12, RX R 50 2T 09-12
PEUGEOT	SUPERMOTARD 50 2T 90-02, XP6 TRAIL S/AVV. ELETTRICO 50 2T 90-02, XR6 RACING CAT. C/AVV.ELETT. 50 2T 90-02
RIEJU	MRT 50 2T 09-12, MRT 50 EU4 50 2T 18-20, MRT PRO 50 2T 09-12, MRT PRO EU4 50 2T 18-20, MRT PRO REPLICIA EU4 50 2T 18-20, MRT PRO REPLICIA SM EU4 50 2T 18-20, MRT PRO SM 50 2T 09-12, MRT PRO SM EU4 50 2T 18-20, MRT SM 50 2T 09-12, MRT SM EU4 50 2T 18-20, MRT TROPHY EU4 50 2T 18-20, MRX 50 2T 01-04, MRX PRO 50 2T 01-04, RR 50 2T 05-06, RS1 50 2T 98-01, RS2 MATRIX 50 2T 05-06, RS2 MATRIX PRO 50 2T 05-06, RS2 NAKED 50 2T 04-05, RS3 EU4 50 2T 18-20, RS3 NKD EU4 50 2T 18-20, SMX E.S./K.S. 50 2T 01-01, SMX PRO E.S./K.S. 50 2T 03-03, SPIKE 50 2T 98-01
SHERCO	FACTORY SE-R EU4 50 2T 18-20, FACTORY SE-RS EU4 50 2T 18-20, FACTORY SILVER SM-R EU4 50 2T 18-20, FACTORY SILVER SM-RS EU4 50 2T 18-20, FACTORY SM-R EU4 50 2T 18-20, FACTORY SM-RS EU4 50 2T 18-20, HRD ENDURO 50 2T 09-13, HRD MOTARD 50 2T 09-13
VENT	BAJA 50 2T 18-20, BAJA RR 50 2T 18-20, DERAPAGE 50 2T 18-20, DERAPAGE RR 50 2T 18-20
YAMAHA	DT R 50 2T 03-11, DT RSM 50 2T 03-05, DT X 50 2T 06-11, TZR 50 2T 03-08, TZR 50 2T 10-11, TZR RR 50 2T 05-05

RICAMBI

PT00150	Pistone completo Ø 49
PT150	Pistone completo Ø 49,5
SG15679	Serie segmenti Ø 49

SG15698	Serie segmenti Ø 49,5
GR00712	Serie guarnizioni
TS00174	Testa

cod. **KT00133**

Gruppo termico Ø 49 Piaggio 4T



APPLICABILITÀ

APRILIA	SCARABEO 4T 50 4T 02-06, SCARABEO 4T RESTYLING EU3 50 4T 06-09, SPORT CITY ONE 4T 50 4T 08-10
DERBI	ATLANTIS 4T 50 4T 04-06, ATLANTIS 4T EU2 50 4T 07-07, BOULEVARD 4T EU2 25KM/H 50 4T 09-09
ITALJET	TORPEDO 50 4T 97-00
MALAGUTI	CENTRO EURO 2 50 4T 08-08, CENTRO SL 4T 50 4T 10-10, CIAK MASTER 4T 50 4T 05-06, CIAK MASTER EURO 2 50 4T 05-06

PIAGGIO	FLY 4T 50 4T 05-07, FLY 4T & 25-30 KM/H 50 4T 08-11, FLY 4T MOTORE CHN 50 4T 06-07, LIBERTY 4T 50 4T 00-02, LIBERTY 4T 50 4T 05-08, LIBERTY 4T DELIVERY - SINGLE 50 4T 10-14, LIBERTY 4T DELIVERY TNT 50 4T 09-09, LIBERTY 4T PTT - DOUBLE - NEXIVE 50 4T 09-17, LIBERTY 4T RST 50 4T 04-04, LIBERTY 4T SPORT 50 4T 06-08, LIBERTY MOC 4T & ELLE 50 4T 09-16, VESPA ET4 50 4T 00-05, VESPA LX 4T 50 4T 05-09, ZIP 4T 50 4T 00-13
----------------	--

RICAMBI

PT00159	Pistone Ø 49
PT159	Pistone Ø 49,5
SG15715	Serie segmenti Ø 49

SG15716	Serie segmenti Ø 49,5
SP00746	Spinotto + anellini Kymco Ø 50 4T
GR00737	Serie guarnizioni

ATTENZIONE: QUESTI PRODOTTI SONO DESTINATI ESCLUSIVAMENTE AD USO AGONISTICO. NE È QUINDI VIETATO L'UTILIZZO SU STRADA PUBBLICA.



◀ cod. **KT00012**
Gruppo termico Vespa Ø 53 3 travasi

APPLICABILITÀ

PIAGGIO APE 50 2T 09-17, APE FL - FL2 50 2T 89-95, APE FL3 EUROPA 50 2T 96-99, APE MIX 2T 50 2T 98-08, APE P 50 2T 80-85, APE RST MIX 50 2T 99-03, APE TM P 50 2T 85-89, VESPA FL 50 2T 90-90, VESPA FL2 HP 50 2T 91-97, VESPA N 50 2T 89-90, VESPA PK 50 2T 82-84, VESPA PK XL 50 2T 85-88, VESPA PK XL RUSH 50 2T 88-89, VESPA SPECIAL-L-R 50 2T 67-82

RICAMBI

PT00060	Pistone Ø 50
PT60	Pistone Ø 50,4
SG15173	Serie segmenti Ø 50
SG15175	Serie segmenti Ø 50,4

SG15177	Serie segmenti Ø 50,8
GR00727	Serie guarnizioni
TS00151	Testa



◀ cod. **KT00132**
Gruppo termico Ø 50 Kymco 4T

APPLICABILITÀ

BAOTIAN ECO BIKE 50 4T 00-04, REBEL 50 4T 03-06, ROCHY 50 4T 03-06, TANCO 50 4T 03-06
GARELLI CAPRI LX 50 4T 06-08, CICLONE 50 4T 06-08, FLEXI 50 4T 08-11, NEW VIP 50 4T 06-07, TIESSE 4T 50 4T 08-10, VIP 50 4T 06-06
HUPPER MONTECARLO 30 50 4T 11-11
KYMCO AGILITY 4T CARRY 50 4T 11-11, AGILITY 4T R10 50 4T 06-08, AGILITY 4T R12 50 4T 07-08, AGILITY PLUS 4T 50 4T 14-14, AGILITY R12 50 4T 05-05, AGILITY R12 ECS 50 4T 16-16, AGILITY R16 50 4T 08-09, AGILITY R16 50 4T 12-12, AGILITY RS 50 4T 09-09, DINK 50 4T 50 4T 07-07, FILLY 50 4T 98-00, FILLY LX 50 4T 01-02, LIKE 50 4T 09-09, PEOPLE S 4T 50 4T 06-08, SENTO 50 4T 08-08, SUPER 8 4T 50 4T 07-07, SUPER 8 4T 50 4T 09-09, VITALITY 4T 50 4T 04-04

MALAGUTI DVD 50 4T 10-10
PEUGEOT V-CLIC 50 4T 90-02
RIEJU PACIFIC 50 4T 07-08, PASEO 50 4T 07-08, TOREO 50 4T 07-08
SYM SYMPLY EURO 2 50 4T 07-08
WT MOTORS BILBAO 50 4T 11-15

RICAMBI

PT00158	Pistone Ø 50
PT158	Pistone Ø 50,5
SG15713	Serie segmenti Ø 50

SG15714	Serie segmenti Ø 50,5
SP00746	Spinotto + anellini Kymco Ø 50 4T
GR00736	Serie guarnizioni



◀ cod. **KT00014**
Gruppo termico Vespa Ø 55 6 travasi

APPLICABILITÀ

PIAGGIO APE 50 2T 09-17, APE FL - FL2 50 2T 89-95, APE FL3 EUROPA 50 2T 96-99, APE MIX 2T 50 2T 98-08, APE P 50 2T 80-85, APE RST MIX 50 2T 99-03, APE TM P 50 2T 85-89, VESPA FL 50 2T 90-90, VESPA FL2 HP 50 2T 91-97, VESPA N 50 2T 89-90, VESPA PK 50 2T 82-84, VESPA PK XL 50 2T 85-88, VESPA PK XL RUSH 50 2T 88-89, VESPA SPECIAL-L-R 50 2T 67-82

RICAMBI

PT00062	Pistone Ø 55
PT62	Pistone Ø 55,4
SG15178	Serie Segmenti Ø 55

SG15180	Serie Segmenti Ø 55,4
GR00727	Serie guarnizioni
TS00153	Testa



◀ cod. **KT00015**
Gruppo termico Vespa Ø 57 ET3 con testa

APPLICABILITÀ

PIAGGIO VESPA ET3 125 2T 76-83, VESPA PRIMAVERA 125 2T 67-83

RICAMBI

PT00063	Pistone completo Ø 57
PT63	Pistone completo Ø 57,4
SG15186	Serie segmenti Ø 57

SG15187	Serie segmenti Ø 57,4
GR00728	Serie guarnizioni
TS00158	Testa

ATTENZIONE: QUESTI PRODOTTI SONO DESTINATI ESCLUSIVAMENTE AD USO AGONISTICO. NE È QUINDI VIETATO L'UTILIZZO SU STRADA PUBBLICA.



◀ cod. **KT00018**
Gruppo termico Ø 60 PX 80

APPLICABILITÀ
PIAGGIO VESPA PX E (DEU) 80 2T 81-97

RICAMBI

PT00065	Pistone completo Ø 60
PT65	Pistone completo Ø 60,4
SG15582	Serie segmenti Ø 60

SG15583	Serie segmenti Ø 60,4
GR00729	Serie guarnizioni
TS00157	Testa



◀ cod. **KT00017**
Gruppo termico Vespa Ø 63 PX

APPLICABILITÀ
LML STAR DELUXE EU1 125 2T 01-03, STAR DELUXE EU3 125 2T 08-09, STAR DELUXE EU1 150 2T 01-03, STAR DELUXE EU3 150 2T 08-09
PIAGGIO VESPA PX 125 2T 98-01, VESPA PX 125 2T 11-16, VESPA PX 30 ANNI 125 2T 07-08, VESPA PX E ARCOBALENO 125 2T 81-97, VESPA PX EU2 125 2T 01-07, VESPA PX 150 2T 98-01, VESPA PX E ARCOBALENO 150 2T 81-97

RICAMBI

PT00064	Pistone completo Ø 63
PT64	Pistone completo Ø 63,4
SG15194	Serie segmenti Ø 63
SG15196	Serie segmenti Ø 63,4

SG15198	Serie segmenti Ø 63,8
GR00729	Serie guarnizioni
TS00156	Testa



◀ cod. **KT00019**
Gruppo termico Ø 69 per Piaggio Ape P 601 Car spinotto 18

APPLICABILITÀ
PIAGGIO APE CAR P2 (1° SERIE) 220 2T 78-82, APE P 501 220 2T 78-85, APE P 601 220 2T 78-83, APE P 601V 220 2T 78-83

RICAMBI

PT00067	Pistone Ø 69 spinotto 18
PT67	Pistone Ø 69,4 spinotto 18
SG15146	Serie segmenti Ø 69

SG15147	Serie segmenti Ø 69,4
SG15149	Serie segmenti Ø 69,8
GR00730	Serie guarnizioni

◀ cod. **KT00020**
Gruppo termico Ø 69 per Piaggio Ape MP MPV spinotto 16

APPLICABILITÀ
PIAGGIO APE MP 220 2T 78-96, APE MPM 600 220 2T 78-83, APE MPR 500 220 2T 78-83, APE MPV 600 220 2T 78-83

RICAMBI

PT00066	Pistone Ø 69 spinotto 16
SG15147	Serie segmenti Ø 69,4

SG15149	Serie segmenti Ø 69,8
SG15146	Serie segmenti Ø 69

SERIE GUARNIZIONI MOTORE

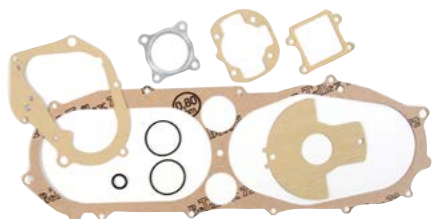

◀ cod. **GR06412**
Serie guarnizioni per motore scooter 50 cc Minarelli/Yamaha tipo verticale

◀ cod. **GR06413**
Serie guarnizioni per motore scooter 50 cc Minarelli/Yamaha orizzontale corto

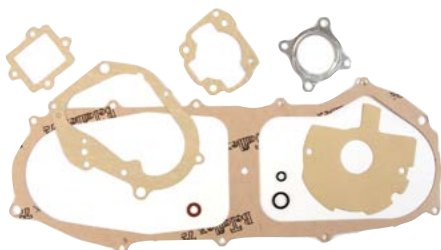

◀ cod. **GR06414**
Serie guarnizioni motore scooter 50 cc Minarelli/Yamaha orizzontale lungo

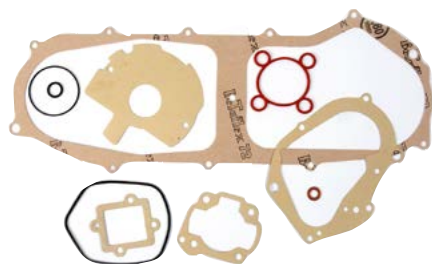

◀ cod. **GR06415**
Serie guarnizioni motore scooter 50 cc Minarelli/Yamaha Liquid Cooled

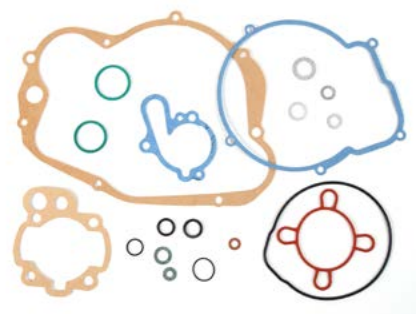

◀ cod. **GR06416**
Serie guarnizioni completa per AM6 EU-1

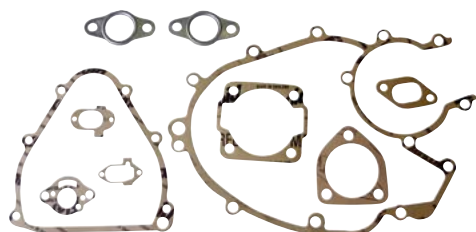

◀ cod. **GR00740**
Serie guarnizioni motore Piaggio Vespa 50 - 50 Special - 90

RIFERIMENTO ORIGINALE

Piaggio	091925
---------	--------

SERIE GUARNIZIONI MOTORE

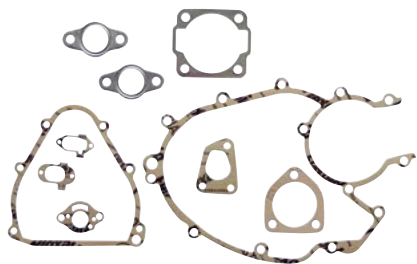

◀ cod. **GR00741**
Serie guarnizioni motore Vespa PK50-XL-FL

RIFERIMENTO ORIGINALE

Piaggio	154616
---------	--------

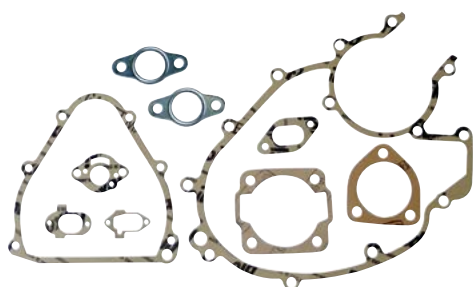

◀ cod. **GR00742**
Serie guarnizioni motore Vespa 125 Primavera

RIFERIMENTO ORIGINALE

Piaggio	153509
---------	--------

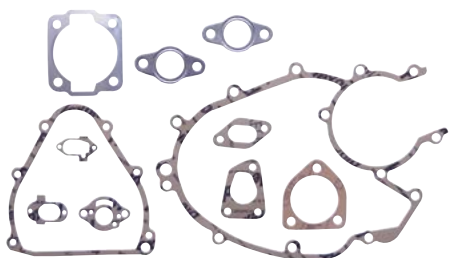

◀ cod. **GR00743**
Serie guarnizioni motore Vespa PK125-XL

RIFERIMENTO ORIGINALE

Piaggio	154630
---------	--------



◀ cod. **GR00744**
Serie guarnizioni motore Vespa PX125-150

RIFERIMENTO ORIGINALE

Piaggio	497603
---------	--------



◀ cod. **GR00745**
Serie guarnizioni motore Piaggio Vespa PX 98-01 - PX200

RIFERIMENTO ORIGINALE

Piaggio	155446
---------	--------

GUARNIZIONI BASE CILINDRO

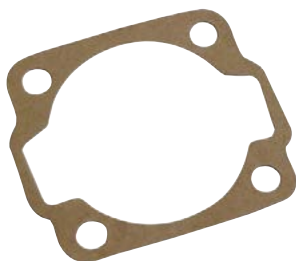

◀ cod. **GR06337**
Guarnizione base cilindro
Vespa 50/90 125 Primavera - ET3

GUARNIZIONI ASPIRAZIONE



◀ cod. **GR00739**
Guarnizione per raccordo aspirazione con flangia a tre fori Vespa PK50-PK125

RIFERIMENTO ORIGINALE

Piaggio	196931
---------	--------

GUARNIZIONI SCARICO



◀ cod. **GR00671**
Guarnizione scarico klingerite fori Ø 6 mm
Vespa PK 50



◀ cod. **GR00673**
Guarnizione raccordo scarico klingerite
Vespa PK 125



◀ cod. **GR00675**
Guarnizione scarico klingerite fori Ø 8 mm
Vespa 125 PK - ET3 - PX

SCARICHI PROMA



◀ cod. **MT00001**
Marmitta Proma per Vespa 50

APPLICABILITÀ

PIAGGIO VESPA SPECIAL-L-R 50 2T 67-82

RICAMBI

CT00801	Collettore marmitta proma per Vespa 50 cc
ML00830	Molla scarico proma

◀ cod. **MT00002**
Marmitta Proma per Vespa 125

APPLICABILITÀ

PIAGGIO VESPA ET3 125 2T 76-83, VESPA PRIMAVERA 125 2T 67-83

RICAMBI

CT00802	Collettore marmitta proma per Vespa 125 cc
ML00830	Molla scarico proma

◀ cod. **MT00024**
Marmitta Proma per Vespa PK 50

APPLICABILITÀ

PIAGGIO VESPA PK 50 S / XL / XL2 / HP

RICAMBI

CT00804	Collettore marmitta proma per Vespa PK 50 cc
ML00830	Molla scarico proma

◀ cod. **MT00027**
Marmitta Proma per Vespa PK 125

APPLICABILITÀ

PIAGGIO VESPA PK 125 / XL

RICAMBI

CT00807	Collettore marmitta proma per Vespa PK125 cc
ML00830	Molla scarico proma



SCARICHI PROMA



◀ cod. **MT00025**
Marmitta Proma Circuit Pro-AS

APPLICABILITÀ
PIAGGIO CIAO BRAVO



◀ cod. **MT00026**
Marmitta Proma City Power Piaggio Ciao '88

APPLICABILITÀ
PIAGGIO CIAO '88

SERIE SEGMENTI

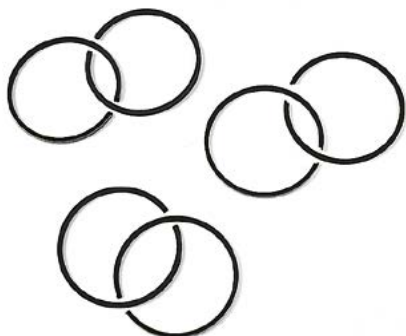

- ◀ cod. **SG15699**
2 segmenti AC 2 x mm 1,5 semitrapezoidali (1 in cromo)
Ø 40 Minarelli/Yamaha
- ◀ cod. **SG15701**
2 segmenti AC 2 x mm 1,5 semitrapezoidali (1 in cromo)
Ø 40,5 Minarelli/Yamaha
- ◀ cod. **SG15702**
2 segmenti AC 2 x mm 1,5 semitrapezoidali (1 in cromo)
Ø 41 Minarelli/Yamaha
- ◀ cod. **SG15703**
2 segmenti AC 4 x mm 1,2 semitrapezoidali (1 in cromo)
Ø 40 Minarelli/Yamaha
- ◀ cod. **SG15704**
2 segmenti AC 4 x mm 1,2 semitrapezoidali (1 in cromo)
Ø 40,5 Minarelli/Yamaha
- ◀ cod. **SG15705**
2 segmenti AC 4 x mm 1,2 semitrapezoidali (1 in cromo)
Ø 41 Minarelli/Yamaha
- ◀ cod. **SG15682**
2 segmenti AC 4 x mm 1,2 (grano interno) Ø 40
- ◀ cod. **SG15683**
2 segmenti AC 4 x mm 1,2 (grano interno) Ø 40,5
- ◀ cod. **SG15684**
2 segmenti AC 4 x mm 1,2 (grano interno) Ø 41







◀ cod. **SCS000004**
Coperchio della scatola frizione

APPLICABILITÀ

BMW K LT 1200 4T 97-09

RIFERIMENTO ORIGINALE

BMW	21212333449
BMW	2333449

SACHS	3072000004
-------	------------



◀ cod. **SCS092230**
Coperchio della scatola frizione

APPLICABILITÀ

BMW R 45 450 4T 81-81, R 65 650 4T 81-92, R 65 G/S 650 4T 81-92, R 65 RT 650 4T 82-86, R 80 800 4T 80-80, R 80 /7 800 4T 77-80, R 80 GS 800 4T 80-94, R 80 GS PARIS DAKAR 800 4T 90-93, R 80 GS/2 800 4T 90-98, R 80 RT 800 4T 82-84, R 80 RT/2 800 4T 85-95, R 80 ST 800 4T 82-87, R 100 1000 4T 81-84, R 100 CS 1000 4T 80-85, R 100 GS 1000 4T 86-96, R 100 GS PARIS DAKAR 1000 4T 89-96, R 100 RS 1000 4T 81-92, R 100 RT 1000 4T 81-96

RIFERIMENTO ORIGINALE

BMW	1242355
BMW	1457280
BMW	21211242355

BMW	21211457280
SACHS	3072092230



◀ cod. **SCS130330**
Coperchio della scatola frizione

APPLICABILITÀ

BMW R GS 850 4T 94-00, R R 850 4T 95-01, R RT 850 4T 95-01, R GS 1100 4T 93-99, R R 1100 4T 95-01, R RS 1100 4T 92-01, R RT 1100 4T 96-01

RIFERIMENTO ORIGINALE

BMW	1341322
BMW	1341585
BMW	21211341322
BMW	21211341585

BMW	21212330024
BMW	2330024
SACHS	3072130330



◀ cod. **SCS135132**
Coperchio della scatola frizione

APPLICABILITÀ

BMW R C 850 4T 97-01, R R 850 4T 00-07, R RT 850 4T 01-06, R S 1100 4T 98-05, R GS 1150 4T 99-04, R GS ADVENTURE 1150 4T 02-05, R R 1150 4T 01-06, R RS 1150 4T 01-05, R RT 1150 4T 01-05

RIFERIMENTO ORIGINALE

BMW	21212333023
BMW	2333023

SACHS	3072135132
-------	------------



◀ cod. **SCS135530**
Coperchio della scatola frizione

APPLICABILITÀ

BMW R C AVANTGARDE 1200 4T 98-02, R C INDEPENDENT 1200 4T 00-05, R C MONTAUK 1200 4T 04-05, R CL 1200 4T 03-05

RIFERIMENTO ORIGINALE

BMW	21212332467
BMW	21212333322
BMW	2332467

BMW	2333322
SACHS	3072135530



◀ cod. **SCS136030**
Coperchio della scatola frizione

APPLICABILITÀ

BMW K 1 1000 4T 89-93, K 100 LT 1000 4T 83-92, K 100 RS 1000 4T 83-89, K 100 RS 16V 1000 4T 89-82, K 100 RT 1000 4T 83-89, K 1100 LT 1100 4T 90-98, K 1100 RS 1100 4T 92-96, K GT 1200 4T 01-05, K RS 1200 4T 97-05

RIFERIMENTO ORIGINALE

BMW	1451273
BMW	21211451273
BMW	21212333472

BMW	2333472
SACHS	3072136030



◀ cod. **SDF000122**
Disco frizione

APPLICABILITÀ

BMW K GT 1200 4T 01-05, K LT 1200 4T 97-09, K RS 1200 4T 97-05

RIFERIMENTO ORIGINALE

BMW	21212332090
BMW	21212332973
BMW	21217670455
BMW	2332090

BMW	2332973
BMW	7670455
SACHS	1864000122



◀ cod. **SDF000124**
Disco frizione

APPLICABILITÀ

BMW R C 850 4T 97-01, R R 850 4T 00-07, R RT 850 4T 01-06, R S 1100 4T 98-05, R GS 1150 4T 99-04, R GS ADVENTURE 1150 4T 02-05, R R 1150 4T 01-06, R RS 1150 4T 01-05, R RT 1150 4T 01-05, R C AVANTGARDE 1200 4T 98-02, R C INDEPENDENT 1200 4T 00-05, R C MONTAUK 1200 4T 04-05, R CL 1200 4T 03-05

RIFERIMENTO ORIGINALE

BMW	21212333262
BMW	21217670454
BMW	2333262

BMW	7670454
SACHS	1864000124



◀ cod. **SDF001744**
Disco frizione

APPLICABILITÀ

BMW R 50 /5 500 4T 69-73, R 60 /5 600 4T 69-73, R 60 /6 600 4T 74-76, R 60 /7 600 4T 76-80, R 60 T 600 4T 76-80, R 75 /5 750 4T 69-73, R 75 /6 750 4T 73-76, R 75 /7 750 4T 76-79, R 90 /6 900 4T 73-76, R 90 S 900 4T 73-76, R 100 /7 1000 4T 76-80, R 100 /T, RT 1000 4T 78-80, R 100 RS 1000 4T 76-80, R 100 S 1000 4T 76-80

RIFERIMENTO ORIGINALE

SACHS	1864001744
-------	------------



◀ cod. **SDF373033**
Disco frizione

APPLICABILITÀ

BMW R 45 450 4T 78-80, R 65 650 4T 78-80

RIFERIMENTO ORIGINALE

BMW	1237571
BMW	21211237571

SACHS	1864373033
-------	------------



◀ cod. **SDF378132**

Disco frizione

APPLICABILITÀ

BMW R 45 450 4T 81-81, R 65 650 4T 81-92, R 65 G/S 650 4T 81-92, R 65 RT 650 4T 82-86, R 80 800 4T 80-80, R 80 /7 800 4T 77-80, R 80 GS 800 4T 80-94, R 80 GS PARIS DAKAR 800 4T 90-93, R 80 GS/2 800 4T 90-98, R 80 RT 800 4T 82-84, R 80 RT/2 800 4T 85-95, R 80 ST 800 4T 82-87, R 100 1000 4T 81-84, R 100 CS 1000 4T 80-85, R 100 GS 1000 4T 86-96, R 100 GS PARIS DAKAR 1000 4T 89-96, R 100 RS 1000 4T 81-92, R 100 RT 1000 4T 81-96

RIFERIMENTO ORIGINALE

BMW	1242370
BMW	1451512
BMW	21211242370

BMW	21211451512
SACHS	1864378132



◀ cod. **SDF400031**

Disco frizione

APPLICABILITÀ

BMW K 1 1000 4T 89-93, K 100 LT 1000 4T 83-92, K 100 RS 1000 4T 83-89, K 100 RS 16V 1000 4T 89-82, K 100 RT 1000 4T 83-89, K 1100 LT 1100 4T 90-98, K 1100 RS 1100 4T 92-96

RIFERIMENTO ORIGINALE

BMW	1451271
BMW	1451721
BMW	1464795
BMW	21211451271

BMW	21211451721
BMW	21211464795
SACHS	1864400031



◀ cod. **SDF419032**

Disco frizione

APPLICABILITÀ

BMW R 75 /2 750 4T 89-96, R 75 C 750 4T 85-88, R 75 RT 750 4T 89-95, R 75 S 750 4T 85-94

RIFERIMENTO ORIGINALE

BMW	1450831
BMW	1454607
BMW	1464796
BMW	21211450831

BMW	2121145460
BMW	21211464796
SACHS	1864419032



◀ cod. **SDF523632**

Disco frizione

APPLICABILITÀ

BMW R GS 850 4T 94-00, R R 850 4T 95-01, R RT 850 4T 95-01, R GS 1100 4T 93-99, R R 1100 4T 95-01, R RS 1100 4T 92-01, R RT 1100 4T 96-01

RIFERIMENTO ORIGINALE

BMW	21212325862
BMW	21212325864
BMW	21217670452
BMW	21217670453
BMW	2325862

BMW	2325864
BMW	7670452
BMW	7670453
SACHS	1864523632

KIT FRIZIONE



◀ cod. **SSD951031**
Kit frizione

APPLICABILITÀ

BMW R GS 850 4T 94-00, R R 850 4T 95-01, R RT 850 4T 95-01, R GS 1100 4T 93-99, R R 1100 4T 95-01, R RS 1100 4T 92-01, R RT 1100 4T 96-01

CONTIENE

Molla a diaframma	SMD001031
Spingidisco frizione	SSD098930
Coperchio della scatola	SC5130330
Disco frizione	SDF523632
Grasso	

RIFERIMENTO ORIGINALE

SACHS	3000951031
-------	------------

MOLLE A DIAFRAMMA



◀ cod. **SMD000001**
Molla a diaframma

APPLICABILITÀ

BMW K GT 1200 4T 01-05, K LT 1200 4T 97-09, K RS 1200 4T 97-05

RIFERIMENTO ORIGINALE

BMW	21212332925
BMW	2332925

SACHS	3054000001
-------	------------



◀ cod. **SMD001031**
Molla a diaframma

APPLICABILITÀ

BMW R 45 450 4T 81-81, R 65 650 4T 81-92, R 65 G/5 650 4T 81-92, R 65 RT 650 4T 82-86, R 80 800 4T 80-80, R 80 /7 800 4T 77-80, R 80 GS 800 4T 80-94, R 80 GS PARIS DAKAR 800 4T 90-93, R 80 GS/2 800 4T 90-98, R 80 RT 800 4T 82-84, R 80 RT/2 800 4T 85-95, R 80 ST 800 4T 82-87, R GS 850 4T 94-00, R R 850 4T 95-01, R RT 850 4T 95-01, R 100 1000 4T 81-84, R 100 CS 1000 4T 80-85, R 100 GS 1000 4T 86-96, R 100 GS PARIS DAKAR 1000 4T 89-96, R 100 RS 1000 4T 81-92, R 100 RT 1000 4T 81-96, R GS 1100 4T 93-99, R R 1100 4T 95-01, R RS 1100 4T 92-01, R RT 1100 4T 96-01

RIFERIMENTO ORIGINALE

BMW	1338508
BMW	21211338508

SACHS	3054001031
-------	------------



◀ cod. **SMD003130**
Molla a diaframma

APPLICABILITÀ

BMW R 75 /2 750 4T 89-96, R 75 C 750 4T 85-88, R 75 RT 750 4T 89-95, R 75 S 750 4T 85-94

RIFERIMENTO ORIGINALE

BMW	1454784
BMW	21211454784

SACHS	3054003130
-------	------------



◀ cod. **SMD004030**
Molla a diaframma

APPLICABILITÀ

BMW K 1 1000 4T 89-93, K 100 LT 1000 4T 83-92, K 100 RS 1000 4T 83-89, K 100 RS 16V 1000 4T 89-82, K 100 RT 1000 4T 83-89, K 1100 LT 1100 4T 90-98, K 1100 RS 1100 4T 92-96

RIFERIMENTO ORIGINALE

BMW	1464092
BMW	21211464092

SACHS	3054004030
-------	------------



◀ cod. **SMD005031**
Molla a diaframma

APPLICABILITÀ

BMW R C 850 4T 97-01, R R 850 4T 00-07, R RT 850 4T 01-06, R S 1100 4T 98-05, R GS 1150 4T 99-04, R GS ADVENTURE 1150 4T 02-05, R R 1150 4T 01-06, R RS 1150 4T 01-05, R RT 1150 4T 01-05, R C AVANTGARDE 1200 4T 98-02, R C INDEPENDENT 1200 4T 00-05, R C MONTAUK 1200 4T 04-05, R CL 1200 4T 03-05

RIFERIMENTO ORIGINALE

BMW	21212345597
BMW	2345597

SACHS	3054005031
-------	------------

SCATOLE FRIZIONE



◀ cod. **SSF133030**
Scatola frizione

APPLICABILITÀ

BMW R C AVANTGARDE 1200 4T 98-02, R C INDEPENDENT 1200 4T 00-05, R C MONTAUK 1200 4T 04-05, R CL 1200 4T 03-05

RIFERIMENTO ORIGINALE

BMW	21212331000
BMW	2331000

SACHS	3072133030
-------	------------



◀ cod. **SSF135031**
Scatola frizione

APPLICABILITÀ

BMW CH26 505 10-19, CH26 EVO 505 16-19

BMW ROXSY 440 08-19, XHEOS 442 08-19, ROXSY 523 08-19

RIFERIMENTO ORIGINALE

BMW	21217666246
BMW	7666246

SACHS	3072135031
-------	------------



◀ cod. **SSD000006**

Spingidisco

APPLICABILITÀ

BMW K GT 1200 4T 01-05, K LT 1200 4T 97-09, K RS 1200 4T 97-05

RIFERIMENTO ORIGINALE

BMW	21212332974
BMW	2332974

SACHS	3071000006
-------	------------



◀ cod. **SSD072030**

Spingidisco

APPLICABILITÀ

BMW R 45 450 4T 81-81, R 65 650 4T 81-92, R 65 G/S 650 4T 81-92, R 65 RT 650 4T 82-86, R 80 800 4T 80-80, R 80 /7 800 4T 77-80, R 80 GS 800 4T 80-94, R 80 GS PARIS DAKAR 800 4T 90-93, R 80 GS/2 800 4T 90-98, R 80 RT 800 4T 82-84, R 80 RT/2 800 4T 85-95, R 80 ST 800 4T 82-87, R 100 1000 4T 81-84, R 100 CS 1000 4T 80-85, R 100 GS 1000 4T 86-96, R 100 GS PARIS DAKAR 1000 4T 89-96, R 100 RS 1000 4T 81-92, R 100 RT 1000 4T 81-96

RIFERIMENTO ORIGINALE

BMW	1242354
BMW	21211242354
BMW	21212302200

BMW	2302200
SACHS	3071072030



◀ cod. **SSD086331**

Spingidisco

APPLICABILITÀ

BMW K 1 1000 4T 89-93, K 100 LT 1000 4T 83-92, K 100 RS 1000 4T 83-89, K 100 RS 16V 1000 4T 89-82, K 100 RT 1000 4T 83-89, K 1100 LT 1100 4T 90-98, K 1100 RS 1100 4T 92-96

RIFERIMENTO ORIGINALE

BMW	1451270
BMW	1464320
BMW	1464570
BMW	21211451270

BMW	21211464320
BMW	21211464570
SACHS	3071086331



◀ cod. **SSD088031**
Spingidisco

APPLICABILITÀ

BMW R 75 /2 750 4T 89-96, R 75 C 750 4T 85-88, R 75 RT 750 4T 89-95, R 75 S 750 4T 85-94

RIFERIMENTO ORIGINALE

BMW	1454408
BMW	1457458
BMW	21211454408

BMW	21211457458
SACHS	3071088031



◀ cod. **SSD098930**
Spingidisco

APPLICABILITÀ

BMW R GS 850 4T 94-00, R R 850 4T 95-01, R RT 850 4T 95-01, R GS 1100 4T 93-99, R R 1100 4T 95-01, R RS 1100 4T 92-01, R RT 1100 4T 96-01

RIFERIMENTO ORIGINALE

BMW	21212325863
BMW	21212330023
BMW	2325863

BMW	2330023
SACHS	3071098930



◀ cod. **SSD099531**
Spingidisco

APPLICABILITÀ

BMW R C 850 4T 97-01, R R 850 4T 00-07, R RT 850 4T 01-06, R S 1100 4T 98-05, R GS 1150 4T 99-04, R GS ADVENTURE 1150 4T 02-05, R R 1150 4T 01-06, R RS 1150 4T 01-05, R RT 1150 4T 01-05, R C AVANTGARDE 1200 4T 98-02, R C INDEPENDENT 1200 4T 00-05, R C MONTAUK 1200 4T 04-05, R CL 1200 4T 03-05

RIFERIMENTO ORIGINALE

BMW	21212333022
BMW	2333022

SACHS	3071099531
-------	------------







◀ cod. **Y02CT01XB**

Coppia contrappesi manubrio blu

Contrappesi in alluminio lavorato dal pieno con inserto anodizzato disponibile in vari colori. Disegnati e progettati per migliorare lo stile del tuo Tmax, proteggono il manubrio in caso di urti o cadute.

- LEGGERI ED ELEGANTI
- PROTEGGONO IL MANUBRIO IN CASO DI CADUTA
- MINIMO INGOMBRO LATERALE
- ALLUMINIO 6082 LAVORATO DAL PIENO
- INSERTI ANODIZZATI DISPONIBILE IN VARI COLORI

APPLICABILITÀ

Yamaha MAJESTY 250 4T 96-03, MAJESTY ABS 250 4T 03-03, MAJESTY DX 250 4T 98-99, MAJESTY 400 4T 04-11, MAJESTY ABS 400 4T 07-11, XP530-A-T-MAX SX 530 4T 17-19, XP530D-A-T-MAX DX 530 4T 17-19, XP530E-A-T-MAX 530 4T 17-18, MT-07 700 4T 14-16, MT-07 MC MOTO CAGE 700 4T 14-14, MT-07A 700 4T 17-18, MT-07A ABS 700 4T 14-16, MT-07A MC MOTO CAGE 700 4T 14-14, MT690 XSR700 700 4T 18-18, MT690-U XSR700 700 4T 18-18, MT690-U XSR700 35KW 700 4T 18-18, XSR 700 4T 16-18



◀ cod. **Y02CT01XO**

Coppia contrappesi manubrio oro



◀ cod. **Y02CT01XR**

Coppia contrappesi manubrio rosso



◀ cod. **Y02CT01XT**

Coppia contrappesi manubrio titanio

COVER FORO SPECCHI



◀ cod. **Y02TS01XB**

Coppia cover attacco specchio blu

Con un design semplice ed elegante si integrano con la carenatura originale del Tmax. Queste cover sono studiate per chiudere il foro di fissaggio degli specchi retrovisori, se questi vengono montati sul manubrio.

- LEGGERI ED ELEGANTI
- IN ALLUMINIO 6082 RICAVATO DAL PIENO
- ANODIZZAZIONE IN PIÙ COLORI
- SI MONTANO SULLA GUARNIZIONE ORIGINALE

APPLICABILITÀ

Yamaha XP530-A-T-MAX SX 530 4T 17-19, XP530D-A-T-MAX DX 530 4T 17-19, XP530E-A-T-MAX 530 4T 17-18



◀ cod. **Y02TS01XO**

Coppia cover attacco specchio oro



◀ cod. **Y02TS01XR**

Coppia cover attacco specchio rosso



◀ cod. **Y02TS01XT**

Coppia cover attacco specchio titanio

LEVA FRENO A MANO

◀ cod. **Y02FS01XB**

Leva freno stazionamento blu



Leva freno di stazionamento esclusiva per Yamaha TMAX, leggera e dal design elegante. L'inserto frontale che incornicia il logo Reckless è disponibile in più colori.

L'inserto posteriore è di colore rosso e indica che il freno di stazionamento è azionato.

- LEGGERA ED ELEGANTE
- IN ALLUMINIO 6082 LAVORATO DAL PIENO
- INSERTO FRONTALE DISPONIBILE IN PIÙ COLORI
- INSERTO POSTERIORE ROSSO

APPLICABILITÀ

Yamaha MAJESTY 400 4T 04-11, MAJESTY ABS 400 4T 07-11, X-MAX RA 400 4T-4V 18-18, T-MAX 4B5 500 4T 09-11, T-MAX 4B5 ABS 500 4T 08-11, T-MAX 5VU 500 4T 04-08, T-MAX SVU ABS 500 4T 05-07, T-MAX SVU BLACK MAX 500 4T 06-06, T-MAX 5VU BLACK MAX - NIGHT MAX 500 4T 07-07, T-MAX SV 500 4T 11-11, T-MAX SV ABS 500 4T 10-11, T-MAX WHITE MAX 500 4T 10-10, T-MAX 59C 530 4T 12-16, T-MAX 59C ABS 530 4T 12-16, T-MAX 59C SP 530 4T 15-15, T-MAX 59C SP ABS 530 4T 15-16, XP530-AT-T-MAX SX 530 4T 17-19, XP530D-A T-MAX DX 530 4T 17-19, XP530E-A T-MAX 530 4T 17-18



◀ cod. **Y02FS01XA** Leva freno stazionamento alluminio



◀ cod. **Y02FS01XO** Leva freno stazionamento oro



◀ cod. **Y02FS01XT** Leva freno stazionamento titanio

PEDALINE PASSEGGERO

◀ cod. **Y02PD01XB**

Coppia pedane passeggero blu



La pedalina Reckless è il frutto di un lungo lavoro di design e tecnologia volto a sviluppare un prodotto che offre elevate caratteristiche meccaniche ed un look esclusivo.

- IN ALLUMINIO 6082 LAVORATO DAL PIENO
- INSERTO DISPONIBILE IN VARI COLORI
- VITERIA PER IL MONTAGGIO INCLUSA

APPLICABILITÀ

Yamaha T-MAX 59C 530 4T 12-16, T-MAX 59C ABS 530 4T 12-16, T-MAX 59C SP 530 4T 15-15, T-MAX 59C SP ABS 530 4T 15-16, XP530-A T-MAX SX 530 4T 17-19, XP530D-A T-MAX DX 530 4T 17-19, XP530E-AT-T-MAX 530 4T 17-18, FZ6 600 4T 04-07, FZ6 FAZER 600 4T 04-07, FZ6 FAZER ABS 600 4T 06-07, FZ6 NS 600 4T 05-06, MT-07 700 4T 14-16, MT-07 MC MOTO CAGE 700 4T 14-14, MT-07A 700 4T 17-18, MT-07A ABS 700 4T 14-16, MT-07A MC MOTO CAGE 700 4T 14-14, FZ8-N 800 4T 11-13, FZ8-N 800 4T 15-15, FZ8-NA 800 4T 11-13, FZ8-NA 800 4T 15-15, FZ8-S 800 4T 11-11, FZ8-S 800 4T 15-15, FZ8-SA 800 4T 11-15, MT-09 850 4T 14-15, MT-09 (MTN850-A) 850 4T 17-18, MT-09 SP (MTN850D) 850 4T 18-18, MT-09A ABS 850 4T 14-16, MT-09A TRACER 850 4T 15-17, XRS900 850 4T 16-18, FZ1 1000 4T 06-09, FZ1 FAZER 1000 4T 06-12, FZ1 FAZER ABS 1000 4T 07-12, FZ1-N 1000 4T 11-11, FZ1-NA 1000 4T 10-11, MT-10 1000 4T 16-18, MT-10D 1000 4T 17-17



◀ cod. **Y02PD01XO** Coppia pedane passeggero oro



◀ cod. **Y02PD01XR** Coppia pedane passeggero rosso



◀ cod. **Y02PD01XT** Coppia pedane passeggero titanio



◀ cod. **Y02PL01RB**

Protezione leva freno dx blu

Per offrire il massimo al tuo TMax, Reckless ha creato un componente dall'animo racing e dal design unico. Progettato e testato per le competizioni, protegge la leva freno da urti che possono causarne l'azionamento accidentale. Il paraleva Reckless è regolabile e ripara leva freno e mani in caso di caduta.

- DESIGN SPORTIVO ED ELEGANTE
- PROTEGGE LA LEVA FRENO E LE MANI DA URTI ACCIDENTALI O CADUTE
- IN ALLUMINIO 6082 RICAVATO DAL PIENO
- INSERTI DISPONIBILI IN PIÙ COLORI
- REGOLABILE

APPLICABILITÀ

Yamaha MAJESTY 250 4T 96-03, MAJESTY ABS 250 4T 03-03, MAJESTY DX 250 4T 98-99, MAJESTY 400 4T 04-11, MAJESTY ABS 400 4T 07-11, XP530-A-T-MAX SX 530 4T 18-19, XP530D-A-T-MAX DX 530 4T 18-19, XP530E-A-T-MAX 530 4T 18-18, MT-07 700 4T 14-16, MT-07 MC MOTO CAGE 700 4T 14-14, MT-07A 700 4T 17-18, MT-07A ABS 700 4T 14-16, MT-07A MC MOTO CAGE 700 4T 14-14, MT690 XSR700 700 4T 18-18, MT690-U XSR700 700 4T 18-18, MT690-U XSR700 35KW 700 4T 18-18, XSR 700 4T 16-18



◀ cod. **Y02PL01RO**
Protezione leva freno dx oro



◀ cod. **Y02PL01RR**
Protezione leva freno dx rosso



◀ cod. **Y02PL01RT**
Protezione leva freno dx titanio

TAPPO FLUIDO FRENI

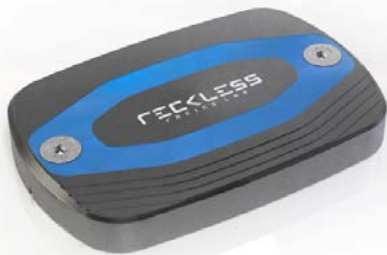

◀ cod. **Y02TF01XB**

Coppia coperchi fluido freni blu

Coperchio serbatoio fluido freni in alluminio lavorato dal pieno con inserto colorato personalizzabile. Design elegante e lavorazioni di qualità. Consente l'utilizzo della guarnizione originale, riportando le indicazioni relative al cambio olio.

- INSERTO ANODIZZATO DISPONIBILE IN VARI COLORI
- COMPATIBILE CON LA GUARNIZIONE ORIGINALE
- INDICAZIONE FLUIDO FRENI DOT4

APPLICABILITÀ

Yamaha MAJESTY 400 4T 09-11, MAJESTY ABS 400 4T 09-11, T-MAX 4B5 500 4T 09-11, T-MAX 4B5 ABS 500 4T 08-11, T-MAX 5VU 500 4T 08-08, T-MAX SV 500 4T 11-11, T-MAX SV ABS 500 4T 10-11, T-MAX WHITE MAX 500 4T 10-10, T-MAX 59C 530 4T 12-16, T-MAX 59C ABS 530 4T 12-16, T-MAX 59C SP 530 4T 15-15, T-MAX 59C SP ABS 530 4T 15-16, XP530-A-T-MAX SX 530 4T 17-19, XP530D-A-T-MAX DX 530 4T 17-19, XP530E-A-T-MAX 530 4T 17-18, XV950 950 4T 14-14, XV950CU 950 4T 14-16, XV950R 950 4T 14-17, XVS1300A MIDNIGHT STAR 1300 4T 11-16, XVS1300CU CUSTOM 1300 4T 14-16

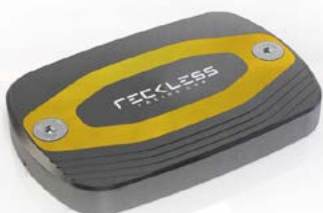

◀ cod. **Y02TF01XO**
Coppia coperchi fluido freni oro



◀ cod. **Y02TF01XR**
Coppia coperchi fluido freni rosso



◀ cod. **Y02TF01XT**
Coppia coperchi fluido freni titanio

TAPPO OLIO MOTORE



◀ cod. **Y02TM01XB**

Tappo carico olio motore blu

Il tappo carico olio motore Reckless è realizzato in alluminio lavorato dal pieno ed è stato progettato per aggiungere stile e colore al Tmax Yamaha.

- LEGGERO ED ELEGANTE
- ALLUMINIO 6082 LAVORATO DAL PIENO
- INSERTO DISPONIBILE IN VARI COLORI
- GUARNIZIONE O-RING INCLUSA

APPLICABILITÀ

Yamaha

T-MAX 4B5 500 4T 09-11, T-MAX 4B5 ABS 500 4T 08-11, T-MAX 5GJ 500 4T 01-03, T-MAX 5VU 500 4T 04-08, T-MAX 5VU ABS 500 4T 05-07, T-MAX 5VU BLACK MAX 500 4T 06-06, T-MAX 5VU BLACK MAX - NIGHT MAX 500 4T 07-07, T-MAX SV 500 4T 11-11, T-MAX SV ABS 500 4T 10-11, T-MAX WHITE MAX 500 4T 10-10, T-MAX 59C 530 4T 12-16, T-MAX 59C ABS 530 4T 12-16, T-MAX 59C SP 530 4T 15-15, T-MAX 59C SP ABS 530 4T 15-16, XP530-A T-MAX SX 530 4T 17-19, XP530D-A T-MAX DX 530 4T 17-19, XP530E-A T-MAX 530 4T 17-18, MT-09 850 4T 14-15, MT-09 (MTN850-A) 850 4T 17-18, MT-09 SP (MTN850D) 850 4T 18-18, MT-09A ABS 850 4T 14-16, MT-09A TRACER 850 4T 15-18, MT-09A TRACER GT (MTT850D) 850 4T 18-18, MXT850 NIKEN 850 4T 18-18, XRS900 850 4T 16-18



◀ cod. **Y02TM01XO** Tappo carico olio motore oro



◀ cod. **Y02TM01XR** Tappo carico olio motore rosso



◀ cod. **Y02TM01XT** Leva freno stazionamento titanio







◀ **cod. XPP1**
OXZT CHAIN LUBE

400 ml

- Lubrificante sintetico trasparente alte prestazioni per trasmissione O-Ring
- Additivi EXTREME PRESSURE e ANTIGOCIA per forti velocità di rotazione
- Forte resistenza del film lubrificante, resiste all'azione dilavante dell'acqua
- Riduce le temperature d'esercizio

Lubrifica uniformemente, non sporca, alta scorrevolezza, protegge la trasmissione dalla corrosione anche in ambienti salini, garantisce elevata resistenza del film lubrificante e limita la generazione del calore allungando i tempi di manutenzione.

OXZT CHAIN LUBE consente l'applicazione in condizioni umide, asciutte, strada, pista, fuoristrada, è composto da

molecole che si ancorano alla superficie e si distribuiscono in modo ordinato per una lubrificazione omogenea. OXZT CHAIN LUBE non necessita di essere utilizzato in grandi quantità per aderire perfettamente alla catena, un eccesso di prodotto andrebbe a sovrapporsi inutilmente creando uno strato non ancorato alla trasmissione.

Modalità d'uso:

- Pulire la trasmissione con OXZT CLEANER (senza acqua) oppure con LINFA BIO MOTO WASH concentrato.
- Agitare OXZT CHAIN LUBE e applicare una moderata quantità sulla trasmissione
- Rimuovere con un panno pulito l'eccesso di lubrificante
- Attendere 2 ore dall'applicazione solo per forti velocità di rotazione (race)



◀ **cod. XPP2**
OXZT CLEANER

500 ml

- Sgrassante parti meccaniche e trasmissione **o-ring**
- Rapida evaporazione senza residui
- Compatibile con parti in gomma
- Erogazione ad alta pressione
- Senza risciacquo

Formulato per sgrassare a fondo senza acqua parti di motore e trasmissione O-RING da unto, grasso, morchia, incrostazioni e catrame, OXZT CLEANER ha un erogatore ad alta pressione sgrassante decontaminante che prepara ad una corretta lubrificazione la trasmissione O-RING e parti meccaniche.

La corretta decontaminazione della trasmissione è indispensabile per garantire un rendimento efficiente del lubrificante catena.

Compatibile con le parti in gomma e plastica, pulisce a fondo anche pompe freno, carburatori, frizioni, parti di motore, ingranaggi, l'esterno motore, steli forcella, sospensioni.

Modalità d'uso:

- Attendere il raffreddamento del motore.
- Agitare prima dell'uso.
- Spruzzare ad una distanza di 15 cm consecutivamente per almeno 4 secondi.
- Se necessario, aiutarsi con un panno F-CLEAN EVO imbevuto con OXZT CLEANER.
- Applicare OXZT CHAIN LUBE per lubrificare la trasmissione.



◀ **cod. XPP3**
LUXE

400 ml

- Protettivo lucidante con silicone
- Resiste alle alte temperature
- Protegge e rinnova parti in gomma e plastiche
- Film protettivo idrorepellente con azione **distaccante**

Resistendo alle alte temperature, protegge e rende brillante tutto il blocco motore, carbonio, scarico completo in titanio e con finiture in carbonio, telaio, gomma, manicotti motore, fodero forcella e plastiche.

Ripristina le parti in gomma deteriorate formando un film trasparente lucido che protegge da corrosione, umidità, sporco, sole e condizioni saline.

Nelle situazioni estreme del fuoristrada crea un film distaccante che riduce l'attaccamento di fango e sporco su cerchi, raggi, carro, telaio, parafanghi, plastiche, scarico, motore, proteggendo anche le parti elettriche dall'acqua

anche durante l'attraversamento di guadi. Contiene silicone, non utilizzare sui freni.

Modalità d'uso:

- Applicare LUXE dopo la pulizia, agitare prima dell'uso.
- Per ottenere massima protezione e creare il potente film distaccante, spruzzare LUXE in modo uniforme da una distanza di 15 cm.
- Per ottenere media brillantezza e creare il potente film protettivo, spruzzare LUXE in modo uniforme da una distanza di 15 cm e distribuire il prodotto con il panno morbido F-CLEAN.
- Spruzzare LUXE su un panno morbido F-CLEAN, distribuire in modo uniforme per ottenere media brillantezza e un potente film protettivo sottile.
- Non utilizzare i panni imbevuti di LUXE con altri prodotti.



◀ cod. **XPP4**
ACTIVE FOAM

400 ml

- Schiuma attiva igienizzante
- Deterge casco e moto con verniciatura opaca e lucida
- Elimina sporco, incrostazioni, olio, moscerini, aloni, sudore.
- Senza acqua e senza risciacquo

Pulisce a fondo carene e casco con verniciatura opaca e lucida, telaio, parti cromate, steli forcella, scarico, strumentazione TFT e touch, manopole, alluminio, acciaio, carbonio, titanio, plastica non verniciata, specchi, plexiglass, rivestimenti ceramici, parti anodizzate, calotta del casco, visiera anche specchiata e rivestimento interno, pelle naturale e sintetica, stivali, tute in pelle. Non rovina adesivi e grafiche. Non contiene silicone. Non utilizzare su pelle scamosciata e nabuk. Teme il gelo.

Modalità d'uso pulizia moto:

- Attendere il raffreddamento del motore e dello scarico.
- Agitare prima dell'uso.
- Per sporchi pesanti, distribuire ACTIVE FOAM sulla parte da pulire, quando la schiuma inizia a dissolversi, rimuovere con il panno F-CLEAN EVO.
- Per sporchi medi, spruzzare ACTIVE FOAM su un panno morbido F-CLEAN EVO e rimuovere lo sporco.
- Procedi a piccole zone, evitando così che il prodotto si dissolva prima di aver completato la rifinitura con il panno.

Modalità d'uso pulizia rivestimento del casco e pelle:

- Agitare e distribuire direttamente sulla parte da trattare.
- Rimuovere con il panno F-CLEAN (oppure con panno ANTIBATTERICO).



◀ cod. **XPP6**
RF54 WHEEL CLEANER

400 ml

- Pulitore e protettivo per cerchi in lega moto
- Elimina con estrema facilità lo sporco più ostinato
- Formulazione con additivi antiruggine, idrorepellenti, anticorrosione
- Senza acqua e senza risciacquo

Elimina lo sporco più ostinato come morchia, incrostazioni, colla, grasso, sporco stradale, catrame, residui di gomma fusa su moto da corsa.

I suoi additivi antiruggine e idrorepellenti formano un film anticorrosione che proteggono i cerchi in lega degli agenti

atmosferici e salini.

Rimuove macchie e sporco ostinato dalle parti verniciate. Non contiene silicone. Non utilizzare sui freni.

Modalità d'uso:

- Applicare **RF54 WHEEL CLEANER** a zone e rimuovere con il panno morbido F-CLEAN, oppure sullo sporco ostinato, lasciare agire un minuto prima di rimuovere.
- Procedi con la pulizia a piccole zone.
- Non utilizzare su dischi, pastiglie freno, in caso di contatto pulire con **STOP BRAKE CLEANER**.



◀ cod. **XPP7**
STOP BRAKE CLEANER

500 ml

- Pulitore freni alte prestazioni
- Evaporazione rapida senza residui
- Erogatore alta pressione

Per qualsiasi impianto frenante ad alte prestazioni, la combinazione di pinza, dischi e pastiglie perfettamente puliti, è fondamentale per assicurarne il corretto funzionamento ed un'usura controllata.

Sgrassa a fondo ed evapora rapidamente, eliminando qualsiasi tipo di sporco e residui di pastiglie organiche, sinterizzate, fino alle carbon-ceramiche. STOP BRAKE CLEANER non lascia residui oleosi e non intacca le parti in

gomma e plastica.

Offre il massimo delle prestazioni anche nelle competizioni più estreme, soddisfacendo le specifiche esigenze di tutti i tipi di moto: maggior controllo, stabilità dell'impianto, aumento della potenza frenante, modulazione della frenata costante.

Modalità d'uso pulizia moto:

- Attendere il raffreddamento dei freni.
- Agitare prima dell'uso.
- Spruzzare direttamente sulla parte, oppure sul panno F-CLEAN EVO e procedere con la pulizia.



◀ **cod. XPP8**
HYDRO –XMULTY erogatore smart
400 ml

- Sbloccante
- Lubrificante
- Protettivo
- Detergente
- Idrorepellente
- Disossidante
- Anticongelante
- Antiruggine
- Anticorrosione anche per uso marino
- Tasto smart con canola doppia erogazione
- Valvola 360° all-position

Sbloccante per dadi, viti, bulloni e meccanismi inceppati a causa di ruggine o incrostazioni. Disossidante per contatti elettrici ed elettronici. Anticongelante per parti motore e meccanismi di precisione. Deterge, lubrifica, protegge leveraggi, perni ruota, molle, pedane e meccanismi di precisione, elimina l'umidità e lo sporco.

Modalità d'uso:

- Agitare prima dell'uso.
- Spruzzare sulla parte.
- Se necessario aiutarsi con un panno.



◀ **cod. XPP11**
CERAFAST
300 ml

- Per parti verniciate e trasparenti di moto e casco
- Naturale e Idrofobizzante
- Vernice brillante e setosa al tatto
- Protegge dalla penetrazione dello sporco, insetti

Già a bassi dosaggi, ha elevate proprietà di scorrimento che garantiscono la rottura immediata del velo d'acqua con effetto seta sulle parti verniciate.

La sua speciale composizione forma un film protettivo persistente, senza stratificare con l'uso, che protegge le superfici trattate dalla penetrazione di sostanze contaminanti (ad esempio insetti).

Previene l'invecchiamento delle superfici, è performante come rifinitura dopo ogni lavaggio ed impedisce

l'aggrapparsi di sporco e agenti atmosferici sulle parti trattate.

Ridona piena lucentezza, lasciando la carrozzeria setosa al tatto.

Non macchia le parti in plastica e gomma, non contiene solventi e abrasivi.

Modalità d'uso:

- Dopo il lavaggio, nebulizzare in modo uniforme sulle parti verniciate e trasparenti.
- Stendere il prodotto con il panno pulito F-CLEAN, senza asciugare completamente.
- Attendere un minuto e rifinire con il panno F-CLEAN asciutto.



◀ **cod. XPP12**
LINFA BIO MOTO WASH trigger
750 ml

- Shampoo concentrato per sporco aderente, con risciacquo
- Rapido e potente, senza solventi petroliferi
- Ideale per la pulizia di moto con cerchi a raggi
- Biodegradabile
- Elimina fango, olio, morchia e grasso
- Concentrato e con risciacquo per la pulizia della trasmissione o-ring e motore

Biodegradabile con additivi, detersivi e sgrassanti specifici per la pulizia delle moto fuoristrada, stradali e da turismo. Può essere utilizzato sia concentrato che diluito per donare protezione e brillantezza a tutte le superfici della moto ed eliminare fango, olio, unto, morchia e grasso. Ideale per pulire componentistica pregiata come carbonio, alluminio, titanio, parti anodizzate e delicate, non compromette l'azione di freno e sospensioni. LINFA BIO MOTO WASH deterge non solo le superfici verniciate ma anche le parti meccaniche, compresa la trasmissione. Non intacca guarnizioni, plastiche, parti in gomma, o-ring, pneumatici e manicotti motore.

Non corrode, non graffia e non macchia.

Pulizia della trasmissione:

- Attendere il raffreddamento del motore.
- Applicare LINFA BIO MOTO WASH concentrato, aiutandosi con pennello o spazzola.
- Sciacquare, asciugare e lubrificare con OXZT CHAIN LUBE.

Pulizia con risciacquo:

- Attendere il raffreddamento del motore, rimuovere con getto d'acqua polvere, fango, sabbia o sporco pesante. Diluire LINFA BIO MOTO WASH fino a 1:10 in un secchio d'acqua a seconda del grado di sporco e procedere con la pulizia aiutandosi con una spugna. Sciacquare con acqua e asciugare.
- Oppure, bagnare con acqua le superfici, spruzzare in modo omogeneo LINFA BIO MOTO WASH concentrato, attendere 2 minuti e rimuovere con getto d'acqua. Se necessario, aggiungere prodotto e aiutarsi con pennello o spugna. Risciacquare con acqua e asciugare.



◀ cod. XPP10

LIFE4X

200 ml

- Crema protettiva per superfici in pelle
- Ristruttura da secchezza e invecchiamento
- Nutre in profondità.

Crema nutriente microtecnologica che rende la pelle morbida e protetta subito senza ungere. Dalla tuta di pelle racing alla giacca, dagli stivali ai guanti, dona protezione waterproof, migliora l'intensità del colore, esalta la finitura naturale e la sensazione al tatto.

Non usare su pelle scamosciata oppure nabuk.

Modalità d'uso:

- Detergere a fondo con ACTIVE FOAM.
- Applicare 0,5 ml di QUESTIONE DI PELLE sul panno F-CLEAN e distribuire uniformemente.
- Attendere l'assorbimento del prodotto all'interno delle superfici trattate.



◀ cod. XPP30

BUBBLE WASH – TRIGGER

750 ml

- Shampoo concentrato vernici lucide e opache
- Necessita risciacquo
- Formulazione con additivi per la pulizia e protezione di parti delicate e cromate
- Compatibile con la trasmissione a cinghia
- Biodegradabile

Shampoo biodegradabile utilizzabile sia concentrato che diluito, elevato potere pulente. Performante su parti opache, lucide, cromate, diamantate, condizioni miste come cerchi a raggi e moto con componentistica pregiata. Elimina olio, grasso, unto, sporco stradale, non contiene solventi petroliferi, non intacca guarnizioni, cinghie,

plastiche, gomma, pneumatici.

Modalità d'uso:

- Attendere il raffreddamento del motore.
- Diluire BUBBLE WASH fino a 1:10 in un secchio d'acqua a seconda del grado di sporco, procedere con la pulizia delle superfici aiutandosi con una spugna, sciacquare con acqua e passare all'asciugatura.
- In alternativa, bagnare con acqua le parti da pulire, spruzzare BUBBLE WASH concentrato in modo omogeneo, attendere 2 minuti e rimuovere con getto d'acqua. Se necessario, aggiungere prodotto e aiutarsi con pennello o spugna. Risciacquare con acqua e asciugare.



◀ cod. XPP31

DEFENCE

300 ml

- Protettivo naturale per vernice opaca
- Impedisce l'aggrapparsi di sporco e insetti
- Barriera antimacchia
- Protegge la vernice opaca dallo sfregamento

DEFENCE ha elevate proprietà protettive di superfici opache, non stratifica con l'uso e la sua barriera antimacchia mantiene inalterata la finitura, difendendola

dallo sfregamento, dalla penetrazione di sporco, macchie, aloni, insetti e dagli agenti atmosferici.

Modalità d'uso:

- Dopo il lavaggio, nebulizzare in modo uniforme sulle parti opache.
- Stendere con il panno pulito F-CLEAN EVO fino alla completa asciugatura.



◀ cod. XPP32

BUBBLE FIZZ

400 ml

- Schiumogeno detergente
- Per verniciature opaca e lucida
- Parti pregiate anodizzate e cromate
- Elimina lo sporco, incrostazioni, olio, moscerini, aloni
- Non contiene siliconi, oli, cera.
- Senza acqua e senza risciacquo

Priva di silicone, cere, polimeri e solventi, BUBBLE FIZZ pulisce in profondità tutte le parti anodizzate e cromate, le verniciature opache e lucide di moto e casco.

BUBBLE FIZZ è una soluzione schiumogena che si deposita sulle superfici e agisce visibilmente sulle parti sollevando lo sporco che può essere immediatamente asportato dal

panno F-CLEAN EVO, senza abrasioni e sfregamenti.

Modalità d'uso:

- Attendere il raffreddamento del motore e dello scarico.
- Agitare prima dell'uso.
- Per sporchi pesanti, distribuire BUBBLE FIZZ sulla parte, quando la schiuma inizia a dissolversi, rimuovere con il panno F-CLEAN EVO.
- Per sporchi medi, spruzzare BUBBLE FIZZ su un panno morbido F-CLEAN EVO e rimuovere lo sporco.
- Procedi a piccole zone, evitando così che il prodotto si dissolva prima di aver completato la rifinitura con il panno.



◀ **cod. XPP21**
DRYPLUS 5 CHAIN SMART

400 ml

- Lubrificante sintetico con azione detergente e protettiva
- Elimina i rumori
- Mantiene a lungo il corretto accoppiamento della trasmissione

Lubrificante con additivi idrospellenti ultima generazione che mantiene a lungo il corretto accoppiamento della trasmissione, aumenta la scorrevolezza, elimina i rumori, proteggendo le superfici dalla corrosione degli agenti

atmosferici e del sale. Contiene additivi detergenti che agevolano anche la pulizia e la lubrificazione di leveraggi, leva freno, guaine e cavi.

Modalità d'uso:

- Per ripristinare la lubrificazione, applicare DRYPLUS5 su pacco pignoni, catena, cambio deragliatore.
- Non utilizzare su piste freno, dischi freno, pattini, pastiglie freno.



◀ **cod. XPP22**
RESET PRO

500 ml

- Pulitore e sgrassatore per meccanismi di precisione
- Manutenzione impianto frenante
- Senza acqua e senza risciacquo

Sgrassa a fondo i componenti di precisione, cambio, deragliatore, pignoni, corone, catena, dischi e pastiglie freno, pattini, pista frenante (sia in carbonio, che in alluminio).

L'erogazione ad alta pressione toglie istantaneamente grasso, sporczia e residui di sporco, agevolando tutte le

operazioni di revisione del meccanismo centrale, mozzi, forcelle, impianto frenante idraulico e tutte le parti che necessitano di una pulizia altamente performante. Rimuove macchie di catrame dalle parti delicate e verniciate, è compatibile con parti in gomma e plastica.

Modalità d'uso:

- Dirigere il getto sulla parte da pulire e vaporizzare per qualche secondo.
- Pulire aiutandosi con il panno F-CLEAN EVO



◀ **cod. XPP23**
FILM FRAME

400 ml

- Barriera protettiva ad effetto brillante
- Per telai in carbonio, titanio, alluminio e acciaio
- Protegge dalla corrosione

Crea un film protettivo lucido che mantiene a lungo brillantezza, elimina la penetrazione delle macchie e agevola la pulizia del telaio. Particolarmente indicato per le bici fuoristrada, FILM FRAME impedisce al fango di aderire, assicurando notevoli benefici in termini di peso. Protegge le superfici prevenendo la penetrazione di sporco stradale, macchie di fango, smog, catrame, corrosione, sale e umidità.

Modalità d'uso:

- Pulire il telaio con MTB PERFECT WASH 750 oppure con E-FOAM
- Applicare direttamente sul telaio.
- Stendere con un panno F-CLEAN e rimuovere il prodotto in eccesso.
- Non utilizzare FILM FRAME su dischi, pastiglie freno, pattini, pista frenante, in caso di contatto pulire con RESET PRO oppure con E-FOAM



◀ cod. XPP24

E-FOAM

400 ml

- Schiumogeno per parti pregiate lucide e opache
- Elimina le incrostazioni, rimuove le macchie di fango
- Sgrassa da olio e aloni non penetra fra gli accoppiamenti.
- Senza acqua e senza risciacquo

Priva di solventi, E-FOAM è la schiuma attiva per il lavaggio senza acqua e senza risciacquo di tutta la bici. Non penetra fra gli accoppiamenti dilavando il lubrificante e deterge senza rovinare guaine, forcelle, pneumatici, parti in gomma, grafiche, adesivi, parti cromate e anodizzate, pedali, sella, manubrio e ruote.

La sua innovativa formulazione non lascia residui oleosi

ed è il detergente ideale per superfici pregiate come telai in carbonio, alluminio e titanio, con verniciatura lucida oppure opaca.

Modalità d'uso:

- Agitare E-FOAM prima dell'uso.
- Spruzzare direttamente su piccole superfici, attendere che il prodotto agisca e quando la schiuma inizia a dissolversi, pulire con il panno F-CLEAN EVO.
- Procedi a piccole zone, per evitare che il prodotto si dissolva prima di aver completato la rifinitura con il panno.



◀ cod. XPP25

MTB X-WASH trigger

750 ml

- Shampoo concentrato sporco aderente finiture lucide e opache
- Necessita risciacquo
- Rapido e potente, senza solventi petroliferi
- Biodegradabile
- Elimina fango, olio, morchie e grasso
- Concentrato e con risciacquo per la pulizia della trasmissione

Shampoo biodegradabile con formulazione selettiva specifico per il lavaggio con acqua e risciacquo.

Si utilizza sia concentrato che diluito per la pulizia e la protezione di carbonio, anodizzazioni, titanio, alluminio, verniciature opache e lucide, senza rovinare pneumatici, parti in gomma, sospensioni.

Elimina fango, olio, grasso, unto, sporco, morchia.

Non compromette l'azione del freno.

Non contiene solventi petroliferi.

Pulizia del gruppo trasmissione:

- Rimuovere polvere, fango, sabbia e sporco pesante con getto d'acqua.
- Applicare MTB PERFECT WASH concentrato sul gruppo trasmissione e attendere 3 minuti.
- Sciacquare con un getto d'acqua diretto sulle superfici, asciugare e lubrificare con DRYPLUS5

Pulizia con risciacquo:

- Rimuovere polvere, fango, sabbia e sporco pesante con getto d'acqua, diluire MTB PERFECT WASH 1:5 in un secchio d'acqua, a seconda del grado di sporco e procedere alla pulizia delle superfici aiutandosi con una spugna. Sciacquare con acqua e asciugare.
- In alternativa, bagnare con acqua le parti da pulire, spruzzare MTB PERFECT WASH concentrato in modo omogeneo e sulla trasmissione, attendere 3 minuti e rimuovere con getto d'acqua. Se necessario, aggiungere prodotto e aiutarsi con spazzola o spugna. Risciacquare e asciugare.



◀ Prodotto disponibile a richiesta

La quantità dei prodotti esposti dipende dalla selezione

altezza 1730 mm

larghezza 480 mm

profondità 350 mm



microcar

MICROCAR AMMORTIZZATORI



◀ cod. **SAM0001**
Coppia ammortizzatori anteriori

APPLICABILITÀ

AIXAM 300 276 96-04, 400 400 96-04, 500,4 400 97-05, A721 400 05-08, A741 400 05-08

RIFERIMENTO ORIGINALE

Aixam	4K009
-------	-------



◀ cod. **SAM0002**
Coppia ammortizzatori posteriori

APPLICABILITÀ

AIXAM 400 400 96-04

RIFERIMENTO ORIGINALE

Aixam	5K003
-------	-------



◀ cod. **SAM0003**
Coppia ammortizzatori anteriori

APPLICABILITÀ

LIGIER NOVA 505 99-04, X-T00 505 02-05

RIFERIMENTO ORIGINALE

Ligier	0200072
--------	---------

Ligier	120.0.070
--------	-----------



◀ cod. **SAM0004**
Coppia ammortizzatori anteriori

APPLICABILITÀ

CHATENET BAROODER 505 08-19

RIFERIMENTO ORIGINALE

Chatenet	10.18.015
----------	-----------



◀ cod. **SAM0005**
Coppia ammortizzatori anteriori

APPLICABILITÀ

CHATENET MEDIA 505 98-01

RIFERIMENTO ORIGINALE

Chatenet	107325
----------	--------



◀ cod. **SAM0006**
Coppia ammortizzatori anteriori

APPLICABILITÀ

JDM ABACA MOUNTAIN 523 07-10

RIFERIMENTO ORIGINALE

JDM	603101
-----	--------

MICROCAR AMMORTIZZATORI



◀ cod. **SAM0007**
Coppia ammortizzatori anteriori

APPLICABILITÀ

JDM ABACA 505 05-19

RIFERIMENTO ORIGINALE

JDM	813101
-----	--------



◀ cod. **SAM0008**
Coppia ammortizzatori anteriori

APPLICABILITÀ

CASALINI YDEA 500 00-00

RIFERIMENTO ORIGINALE

Casalini	F2107000027
----------	-------------



◀ cod. **SAM0009**
Coppia ammortizzatori posteriori

APPLICABILITÀ

CASALINI YDEA 500 00-00

RIFERIMENTO ORIGINALE

Casalini	F2107000025
----------	-------------



◀ cod. **SAM0010**
Coppia ammortizzatori anteriori

APPLICABILITÀ

JDM TITANE 523 99-02

RIFERIMENTO ORIGINALE

JDM	901002
-----	--------



◀ cod. **SAM0011**
Coppia ammortizzatori anteriori

APPLICABILITÀ

GREKAV EKE 505 00-10

RIFERIMENTO ORIGINALE

GrecaV	BAF080007837
--------	--------------



◀ cod. **SAM0012**
Coppia ammortizzatori posteriori

APPLICABILITÀ

LIGIER NOVA 505 99-04

RIFERIMENTO ORIGINALE

Ligier	0200063
--------	---------

MICROCAR AMMORTIZZATORI



◀ cod. **SAM0013**
Coppia ammortizzatori anteriori

APPLICABILITÀ

LIGIER X-T00 R 505 00-19

RIFERIMENTO ORIGINALE

Ligier	0200078
--------	---------



◀ cod. **SAM0014**
Coppia ammortizzatori posteriori

APPLICABILITÀ

LIGIER X-T00 MAX 505 02-05, X-T00 R 505 00-19

RIFERIMENTO ORIGINALE

Ligier	0200076
--------	---------



◀ cod. **SAM0015**
Coppia ammortizzatori anteriori

APPLICABILITÀ

LIGIER JS 50 F1 505 09-12

RIFERIMENTO ORIGINALE

Ligier	1403276
--------	---------



◀ cod. **SAM0016**
Coppia ammortizzatori posteriori

APPLICABILITÀ

LIGIER JS 50 F1 505 09-12

RIFERIMENTO ORIGINALE

Ligier	1403277
--------	---------



◀ cod. **SAM0017**
Coppia ammortizzatori anteriori

APPLICABILITÀ

MICROCAR VIRGO II 505 02-04

RIFERIMENTO ORIGINALE

Microcar	0660145
----------	---------



◀ cod. **SAM0018**
Coppia ammortizzatori posteriori

APPLICABILITÀ

MICROCAR VIRGO II 505 02-04

RIFERIMENTO ORIGINALE

Microcar	0660154
----------	---------

MICROCAR AMMORTIZZATORI



◀ cod. **SAM0019**
Coppia ammortizzatori anteriori

APPLICABILITÀ

ITALCAR T2 505 06-07, T3 505 06-07, DOMINO 06-07

RIFERIMENTO ORIGINALE

Italcar	MY019
---------	-------



◀ cod. **SAM0020**
Coppia ammortizzatori anteriori

APPLICABILITÀ

CHATENET CH26 505 10-19

RIFERIMENTO ORIGINALE

Chatenet	01.26.167
----------	-----------



◀ cod. **SAM0021**
Coppia ammortizzatori anteriori

APPLICABILITÀ

LIGIER JS 50 C 505 00-05

RIFERIMENTO ORIGINALE

Ligier	1403276
--------	---------



◀ cod. **SAM0022**
Coppia ammortizzatori anteriori

APPLICABILITÀ

MICROCAR DUÈ 505 14-14

RIFERIMENTO ORIGINALE

Microcar	1404984
----------	---------



◀ cod. **SAM0023**
Coppia ammortizzatori posteriori

APPLICABILITÀ

MICROCAR DUÈ 505 14-14

RIFERIMENTO ORIGINALE

Microcar	1405146
----------	---------



◀ cod. **SAM0024**
Coppia ammortizzatori anteriori

APPLICABILITÀ

AIXAM CITY ELETTRICA 10-12

RIFERIMENTO ORIGINALE

Aixam	4AT009
-------	--------

MICROCAR AMMORTIZZATORI



◀ cod. **SAM0025**
Coppia ammortizzatori posteriori

APPLICABILITÀ

AIXAM CITY ELETTRICA 10-12

RIFERIMENTO ORIGINALE

Aixam	5K003A
-------	--------



◀ cod. **SAM0026**
Coppia ammortizzatori anteriori

APPLICABILITÀ

LIGIER X-T00 MAX 505 02-05

RIFERIMENTO ORIGINALE

Ligier	0200072
--------	---------



◀ cod. **SAM0027**
Coppia ammortizzatori anteriori

APPLICABILITÀ

AIXAM D-TRUCK 478 12-19

RIFERIMENTO ORIGINALE

Aixam	4L009
-------	-------



◀ cod. **SAM0028**
Coppia ammortizzatori posteriori

APPLICABILITÀ

AIXAM D-TRUCK 478 12-19

RIFERIMENTO ORIGINALE

Aixam	5MB003
-------	--------



◀ cod. **SAM0029**
Coppia ammortizzatori anteriori

APPLICABILITÀ

AIXAM MULTI TRUCK 478 12-19

RIFERIMENTO ORIGINALE

Aixam	4L009
-------	-------



◀ cod. **SAM0030**
Coppia ammortizzatori posteriori

APPLICABILITÀ

AIXAM MULTI TRUCK 478 12-19

RIFERIMENTO ORIGINALE

Aixam	5MB003
-------	--------

MICROCAR AMMORTIZZATORI



◀ cod. **SAM0032**
Coppia ammortizzatori anteriori

APPLICABILITÀ

LIGIER S 20 505 10-10

RIFERIMENTO ORIGINALE

Ligier	0200071
--------	---------



◀ cod. **SAM0035**
Coppia ammortizzatori posteriori

APPLICABILITÀ

CHATENET BAROODER 505 08-19

RIFERIMENTO ORIGINALE

Chatenet	01.18.014
----------	-----------



◀ cod. **SAM0038**
Coppia ammortizzatori posteriori

APPLICABILITÀ

CHATENET CH26 505 10-19

RIFERIMENTO ORIGINALE

Chatenet	01.26.168
----------	-----------



◀ cod. **SAM0039**
Coppia ammortizzatori posteriori

APPLICABILITÀ

CHATENET CH26 MEDIA 505 10-10

RIFERIMENTO ORIGINALE

Chatenet	01.16.005
----------	-----------



◀ cod. **SAM0040**
Coppia ammortizzatori posteriori

APPLICABILITÀ

CHATENET CH26 I 505 10-10

RIFERIMENTO ORIGINALE

Chatenet	01.38.018
----------	-----------

MICROCAR CANDELETTE



◀ cod. **CAMC001**
Candeletta per Yanmar - UTMBY13



◀ cod. **CAMC002**
Candeletta pre-riscaldamento per Lombardini LDW502 – ED0021000890-S - 002100890 0701014 / 0701014



◀ cod. **CAMC003**
Candeletta per motore Kubota 400 cc bicilindrico - K168516551



◀ cod. **CAMC004**
Candeletta per Lombardini LDW422 – ED0021000940-S - 1010539 / 1010539



◀ cod. **CAMC005**
Candeletta per Mitsubishi - F0098000017



◀ cod. **CAMC006**
Candeletta per Lombardini – ED0021001090-S - 0701014 / 0701014

CILINDRETTI FRENO



- ◀ cod. **CAMC006**
Cilindretto freno posteriore Porter 16V VAN - 4755087Z01000

APPLICABILITÀ

PIAGGIO PORTER 1000 4T 92-98, PORTER 1000 PICK-VAN 1000 4T 92-09, PORTER DIESEL 1200 1200 DIESEL 95-00, PORTER 1300 PICK-VAN 1300 4T 92-09, PORTER 16V PICK UP-MAXXI-GPL-4X4 1300 4T 4V 98-09, PORTER 16V VAN 1300 4T 4V 98-07, PORTER UP-DATE 1300 4T 4V 09-10, PORTER DIESEL 1400 1400 DIESEL 95-00, PORTER PICK DIESEL 1400 DIESEL 98-05, PORTER VAN DIESEL 1400 DIESEL 98-05

CINGHIE



- ◀ cod. **CIMC001**
Cinghia V-Belt dentata per Lombardini LDW502 – ED0024403430-S - 0701055 / 0701055



- ◀ cod. **CIMC002**
Cinghia distribuzione per Lombardini LDW422 – ED0024404110-S - 1010470 / 1010470

CUSCINETTI



- ◀ cod. **KCRM001**
Kit cuscinetti ruota anteriore Porter 1.2

APPLICABILITÀ

PIAGGIO QUARGO 500 DIESEL 05-17, PORTER 1000 4T 92-98, PORTER 1000 PICK-VAN 1000 4T 92-09, PORTER D120 ES 1200 DIESEL 11-15, PORTER DIESEL 1200 1200 DIESEL 95-00, PORTER MULTITECH EURO4 - EURO5 - EURO5+ 1300 4T 4V 10-15, PORTER 1300 PICK-VAN 1300 4T 92-09, PORTER 16V PICK UP-MAXXI-GPL-4X4 1300 4T 4V 98-09, PORTER 16V VAN 1300 4T 4V 98-07, PORTER UP-DATE 1300 4T 4V 09-10, PORTER DIESEL 1400 1400 DIESEL 95-00, PORTER PICK DIESEL 1400 DIESEL 98-05, PORTER VAN DIESEL 1400 DIESEL 98-05



- ◀ cod. **KCRM002**
Kit cuscinetti ruota anteriore Microcar - Aixam

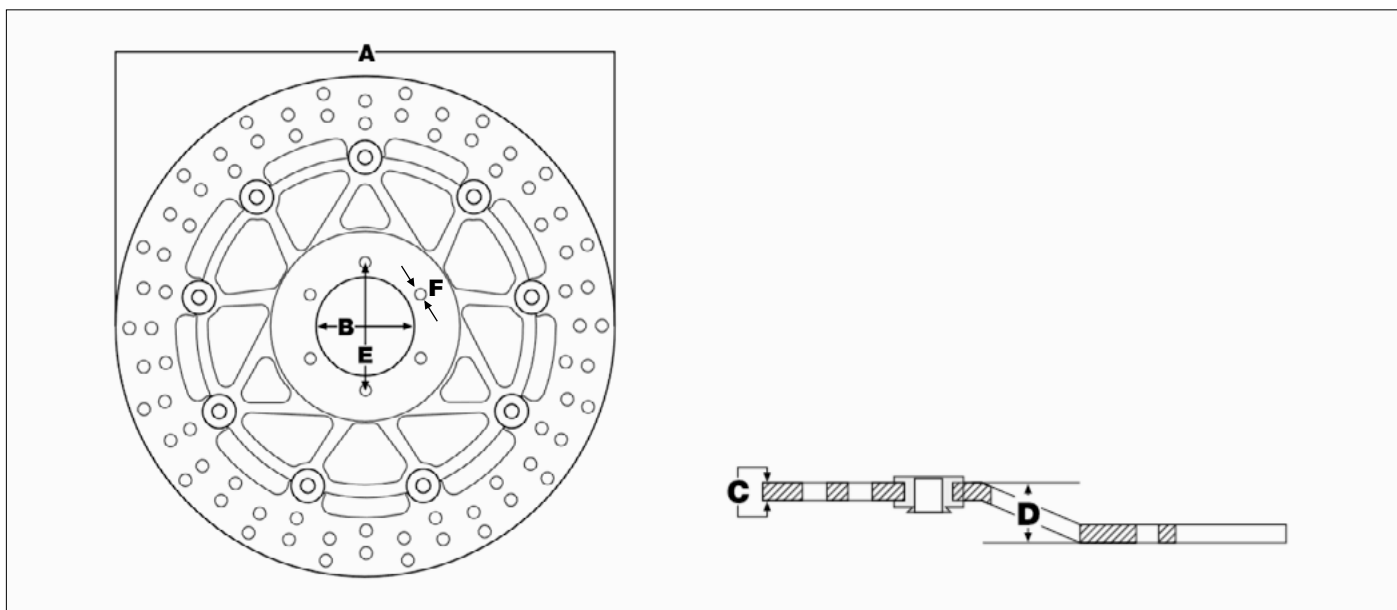

DISCHI FRENO ANTERIORI



◀ cod. **BDM0001**

Disco freno anteriore

APPLICABILITÀ

LIGIER IXO 505 11-19, JS 36 505 14-19, JS 40 505 11-19, JS RC 505 08-19, OPTIMAX 505 00-19

MICROCAR M8 480 16-19, M8 500 16-19, CARGO 505 07-19, DUÉ F1RST 505 11-19, F8 505 11-19, MGO 2 505 08-13

MISURE

A	220	B	58	C	4	D	24,5	E	86	F	10,5
----------	-----	----------	----	----------	---	----------	------	----------	----	----------	------

RIFERIMENTO ORIGINALE

Ligier	1008471	Microcar	1008471
--------	---------	----------	---------



◀ cod. **BDM0005**

Disco freno anteriore

APPLICABILITÀ

CHATENET CH26 505 10-19, CH26 EVO 505 16-19

JDM ROXSY 440 08-19, XHEOS 442 08-19, ROXSY 523 08-19

MISURE

A	225	B	76	C	6	D	18,5	E	96	F	10,5
----------	-----	----------	----	----------	---	----------	------	----------	----	----------	------

RIFERIMENTO ORIGINALE

Chatenet	01.17.367
----------	-----------



◀ cod. **BDM0008**

Disco freno anteriore Piaggio Porter 16V Van - 4351287Z02000

APPLICABILITÀ

PIAGGIO QUARGO 500 DIESEL 05-17, PORTER 1000 PICK-VAN 1000 4T 92-09, PORTER D120 ES 1200 DIESEL 11-15, PORTER DIESEL 1200 1200 DIESEL 95-00, PORETR MULTITECH EURO4 - EURO5 - EURO5+ 1300 4T 4V 10-15, PORETR MULTITECH EURO6 - EURO6-C 1300 4T 4V 15-20, PORETR MULTITECH EURO6 ENTRY LEVEL 1300 4T 4V 17-20, PORTER 1300 PICK-VAN 1300 4T 92-09, PORTER 16V PICK UP-MAXXI-GPL-4X4 1300 4T 4V 98-09, PORTER 16V VAN 1300 4T 4V 98-07, PORTER UP-DATE 1300 4T 4V 09-10, PORTER DIESEL 1400 1400 DIESEL 95-00, PORTER PICK DIESEL 1400 DIESEL 98-05, PORTER VAN DIESEL 1400 DIESEL 98-05

MISURE

A	210	B	70	C	16	D	37	E	97	F	M10x1.25
----------	-----	----------	----	----------	----	----------	----	----------	----	----------	----------

DISCHI FRENO POSTERIORI



cod. **BDM0004**

Disco freno posteriore

APPLICABILITÀ

LIGIER IXO 505 11-19, JS 36 505 14-19, JS 40 505 11-19, JS RC 505 08-19, OPTIMAX 505 00-19

MICROCAR M8 480 16-19, M8 500 16-19, CARGO 505 07-19, DUÈ F1RST 505 11-19, F8 505 11-19, MGO 2 505 08-13

MISURE

A	180	B	64	C	5	E	80	F	6,4
----------	-----	----------	----	----------	---	----------	----	----------	-----

RIFERIMENTO ORIGINALE

Ligier	1412733
Microcar	1412733

Ligier	1412722
Microcar	1412722



cod. **BDM0006**

Disco freno posteriore

APPLICABILITÀ

CHATENET CH26 505 10-19, CH26 EVO 505 16-19

JDM ROXSY 440 08-19, XHEOS 442 08-19, ROXSY 523 08-19

MISURE

A	220	B	64	C	4	E	80	F	6,4
----------	-----	----------	----	----------	---	----------	----	----------	-----

RIFERIMENTO ORIGINALE

Chatenet	01.17.427
----------	-----------



cod. **BDM0007**

Disco freno posteriore

APPLICABILITÀ

CHATENET CH26 505 10-19, CH26 EVO 505 16-19

JDM ROXSY 440 08-19, XHEOS 442 08-19, ROXSY 523 08-19

MISURE

A	200	B	64	C	4	E	80	F	6,4
----------	-----	----------	----	----------	---	----------	----	----------	-----

RIFERIMENTO ORIGINALE

Chatenet	01.17.452
----------	-----------

DISCHI FRENO POSTERIORI VENTILATI



cod. **BDM0002**

Disco freno posteriore ventilato

APPLICABILITÀ

LIGIER IXO 505 11-19, JS 36 505 14-19, JS 40 505 11-19, JS RC 505 08-19, OPTIMAX 505 00-19

MICROCAR M8 480 16-19, M8 500 16-19, CARGO 505 07-19, DUÈ F1RST 505 11-19, F8 505 11-19, MGO 2 505 08-13

MISURE

A	180	B	64	C	4	E	80	F	6,4
----------	-----	----------	----	----------	---	----------	----	----------	-----

RIFERIMENTO ORIGINALE

Ligier	1400353
--------	---------

Microcar	1400353
----------	---------



cod. **BDM0003**

Disco freno posteriore ventilato

APPLICABILITÀ

LIGIER IXO 505 11-19, JS 36 505 14-19, JS 40 505 11-19, JS RC 505 08-19, OPTIMAX 505 00-19

MICROCAR M8 480 16-19, M8 500 16-19, CARGO 505 07-19, DUÈ F1RST 505 11-19, F8 505 11-19, MGO 2 505 08-13

MISURE

A	180	B	64	C	4	E	80	F	6,4
----------	-----	----------	----	----------	---	----------	----	----------	-----

RIFERIMENTO ORIGINALE

Ligier	1400352
--------	---------

Microcar	1400352
----------	---------

DISTRIBUZIONE MOTORE



◀ cod. **KDM0001**
Kit Distribuzione Porter 1.2

APPLICABILITÀ

PIAGGIO QUARGO 500 DIESEL 05-17, QUARGO DIESEL 750 DIESEL 04-06, PORTER DIESEL 1200 1200 DIESEL 95-00, PORTER DIESEL 1400 1400 DIESEL 95-00, PORTER PICK DIESEL 1400 DIESEL 98-05, PORTER VAN DIESEL 1400 DIESEL 98-05

TENDICINGHIA



◀ cod. **TDM0001**
Tendicinghia Distribuzione Porter 1.2

APPLICABILITÀ

LIGIER AMBRA 162 500 DIESEL 98-00, NOVA 500 DIESEL 00-00

PIAGGIO AL DIESEL 500 DIESEL 04-07, M 500 500 DIESEL 03-10, PK 500 500 DIESEL 03-10, QUARGO 500 DIESEL 05-17, QUARGO DIESEL 750 DIESEL 04-06, PORTER DIESEL 1200 1200 DIESEL 95-00, PORTER DIESEL 1400 1400 DIESEL 95-00, PORTER PICK DIESEL 1400 DIESEL 98-05, PORTER VAN DIESEL 1400 DIESEL 98-05

◀ cod. **TDM0002**
Galoppino/jockey per Lombardini – ED0041100090-S - 0640171 / 0640171



◀ cod. **TDM0003**
Galoppino per Lombardini LDW422 – ED0041100500-S - 1010469 / 1010469

KIT DISTRIBUZIONE



◀ cod. **KDM0002**

Kit distribuzione (cinghia galoppino pompa) per motore Idw442 Idw 492 Lombardini - common rail / dci
ED0041100500-S + ED0024404110-S + ED0065845110-S - 1406127 / 1406127



◀ cod. **KDM0003**

Kit distribuzione (con pompa acqua, cinghia con guarnizioni e galoppino) per motore Focs Lombardini LDW 502 – ED0048980750-S - 1402423 / 1402423



◀ cod. **KDM0004**

Kit distribuzione economy (con pompa acqua, cinghia con guarnizioni e galoppino) per motore Focs Lombardini LDW 502 – ED0048980750-S - 1402423 / 1402423

MICROCAR **FILTRI ARIA**



- ◀ cod. **FAMC001**
Filtro aria cilindrico - Lombardini ED0021751660-S - 1003173 / 1003173



- ◀ cod. **FAMC002**
Filtro aria - Aixam (MOTORE KUBOTA) - 1666711081



- ◀ cod. **FAMC003**
Filtro aria - Aixam (MOTORE KUBOTA) - 6C06099410 + 3272158242



- ◀ cod. **FAMC004**
Filtro aria - Casalini Per Motori Mitsubishi - F0098000007



- ◀ cod. **FAMC005**
Filtro aria - Casalini Per Motori Mitsubishi - F0098000173 mitsubishi 63



- ◀ cod. **FAMC006**
Filtro aria - Yanmar



◀ cod. **FAMC007**
Filtro aria - Yanmar - 820001/A - JDM



◀ cod. **FAMC008**
Filtro Aria A Pannello - Lombardini ED0021751640-S - 0640005 / 0640005



◀ cod. **FAMC009**
Filtro Aria Piaggio Porter 16V VAN - 1780187Z08000

RIFERIMENTO ORIGINALE

PIAGGIO	1780187Z08000
---------	---------------

APPLICABILITÀ

PIAGGIO PORTER 1000 PICK-VAN 1000 4T 92-09, PORTER 1300 PICK-VAN 1300 4T 92-09, PORTER 16V VAN 1300 4T 4V 98-07, PORTER MAXXI UP-DATE 1300 4T 4V 09-10, PORTER UP-DATE 1300 4T 4V 09-10



◀ cod. **FAMC010**
Filtro Aria Piaggio Porter Diesel 1200-1400 - 263703

RIFERIMENTO ORIGINALE

PIAGGIO	263703
---------	--------

APPLICABILITÀ

PIAGGIO PORTER D120 ES 1200 DIESEL 11-15, PORTER DIESEL 1200 1200 DIESEL 95-00, PORTER MAXXI D120 EUROS 1200 4T 4V 11-15, PORTER DIESEL 1400 1400 DIESEL 95-00, PORTER PICK DIESEL 1400 DIESEL 98-05, PORTER VAN DIESEL 1400 DIESEL 98-05



◀ cod. **FAMC011**
Filtro aria Piaggio M 500 112165L - 850314

RIFERIMENTO ORIGINALE

PIAGGIO	850314
---------	--------

APPLICABILITÀ

PIAGGIO M 500 500 DIESEL 03-10

MICROCAR *FILTRI CARBURANTE*



◀ cod. **FCMC001**
Filtro carburante Piaggio Porter 16V VAN - 2330087507

APPLICABILITÀ

PIAGGIO PORTER 1000 4T 92-98, PORTER 1000 PICK-VAN 1000 4T 92-09, PORETR MULTITECH EURO4 - EURO5 - EURO5+ 1300 4T 4V 10-15, PORETR MULTITECH EURO6 - EURO6-C 1300 4T 4V 15-20, PORETR MULTITECH EURO6 ENTRY LEVEL 1300 4T 4V 17-20, PORETR MULTITECH MAXXI EURO4 - EURO5 1300 4T 4V 10-15, PORETR MULTITECH MAXXI EURO6 1300 4T 4V 15-19, PORTER 1300 PICK-VAN 1300 4T 92-09, PORTER 16V VAN 1300 4T 4V 98-07, PORTER UP-DATE 1300 4T 4V 09-10



◀ cod. **FCMC002**
Filtro carburante Piaggio M 500 - 850482

APPLICABILITÀ

PIAGGIO M 500 500 DIESEL 03-10

FILTRI GASOLIO



◀ cod. **FGMC001**
Filtro gasolio 1 Serie – Lombardini ED0041100090-S - 1000389



◀ cod. **FGMC002**
Filtro gasolio 2 Serie Fispino Ed0037301210-S - LOMBARDINI - 1000863 /



◀ cod. **FGMC003**
Filtro carburante - Lombardini LDW422 – ED0021752410-S - 1010487 / 1010487



◀ cod. **FGMC004**
Filtro gasolio 2 Serie - Kubota - 6A32059930



◀ cod. **FGMC005**
Filtro gasolio - Casalini



◀ cod. **FGMC006**
Filtro gasolio - Casalini - F0098000162 Mitsubishi 635 cc



◀ cod. **FGMC007**
Filtro gasolio - Yanmar - 1004954



◀ cod. **FGMC008**
FILTRO GASOLIO PIAGGIO PORTER DIESEL 1200-1400 - 493290

RIFERIMENTO ORIGINALE

PIAGGIO	493290
---------	--------

APPLICABILITÀ

PIAGGIO APE CLASSIC 400 4T 14-17, APE CALESSINO - VME 420 4T 07-12, APE MP601 CLASSIC 420 4T 06-13, APETM DIESEL LCS 420 4T 05-12, APE TM P703-P703V DIESEL 420 4T 87-04, PORTER DIESEL 1200 1200 DIESEL 95-00, PORTER DIESEL 1400 1400 DIESEL 95-00, PORTER PICK DIESEL 1400 DIESEL 98-05, PORTER VAN DIESEL 1400 DIESEL 98-05



◀ cod. **FOMC001**
Filtro olio Piaggio Porter 16V VAN - 438038



◀ cod. **FOMC002**
Filtro olio - Lombardini LDW422 - ED0021752180-S - 1010476 / 1010476



◀ cod. **FOMC003**
Filtro olio - Kubota - K158413243



◀ cod. **FOMC004**
Filtro olio - Yanmar / Mitsubishi - F0098000163 - 1004884



◀ cod. **FOMC005**
Filtro olio Piaggio Porter 16V VAN - 438038

RIFERIMENTO ORIGINALE

PIAGGIO	438038
---------	--------

APPLICABILITÀ

PIAGGIO PORTER 1000 4T 92-98



◀ cod. **FOMC006**
Filtro olio Piaggio Porter Diesel 1200-1400 - 493063

RIFERIMENTO ORIGINALE

PIAGGIO	493063
---------	--------

APPLICABILITÀ

PIAGGIO PORTER 1000 PICK-VAN 1000 4T 92-09, PORTER DIESEL 1200 1200 DIESEL 95-00, PORETR MULTITECH EURO4 - EURO5 - EURO5+ 1300 4T 4V 10-15, PORETR MULTITECH EURO6 - EURO6-C 1300 4T 4V 15-20, PORETR MULTITECH EURO6 ENTRY LEVEL 1300 4T 4V 17-20, PORETR MULTITECH MAXXI EURO4 - EURO5 1300 4T 4V 10-15, PORETR MULTITECH MAXXI EURO6 1300 4T 4V 15-19, PORTER 1300 PICK-VAN 1300 4T 92-09, PORTER 16V PICK UP-MAXXI-GPL-4X4 1300 4T 4V 98-09, PORTER 16V VAN 1300 4T 4V 98-07, PORTER MAXXI UP-DATE 1300 4T 4V 09-10, PORTER UP-DATE 1300 4T 4V 09-10, PORTER DIESEL 1400 1400 DIESEL 95-00, PORTER PICK DIESEL 1400 DIESEL 98-05, PORTER VAN DIESEL 1400 DIESEL 98-05

MICROCAR KIT GIUNTI

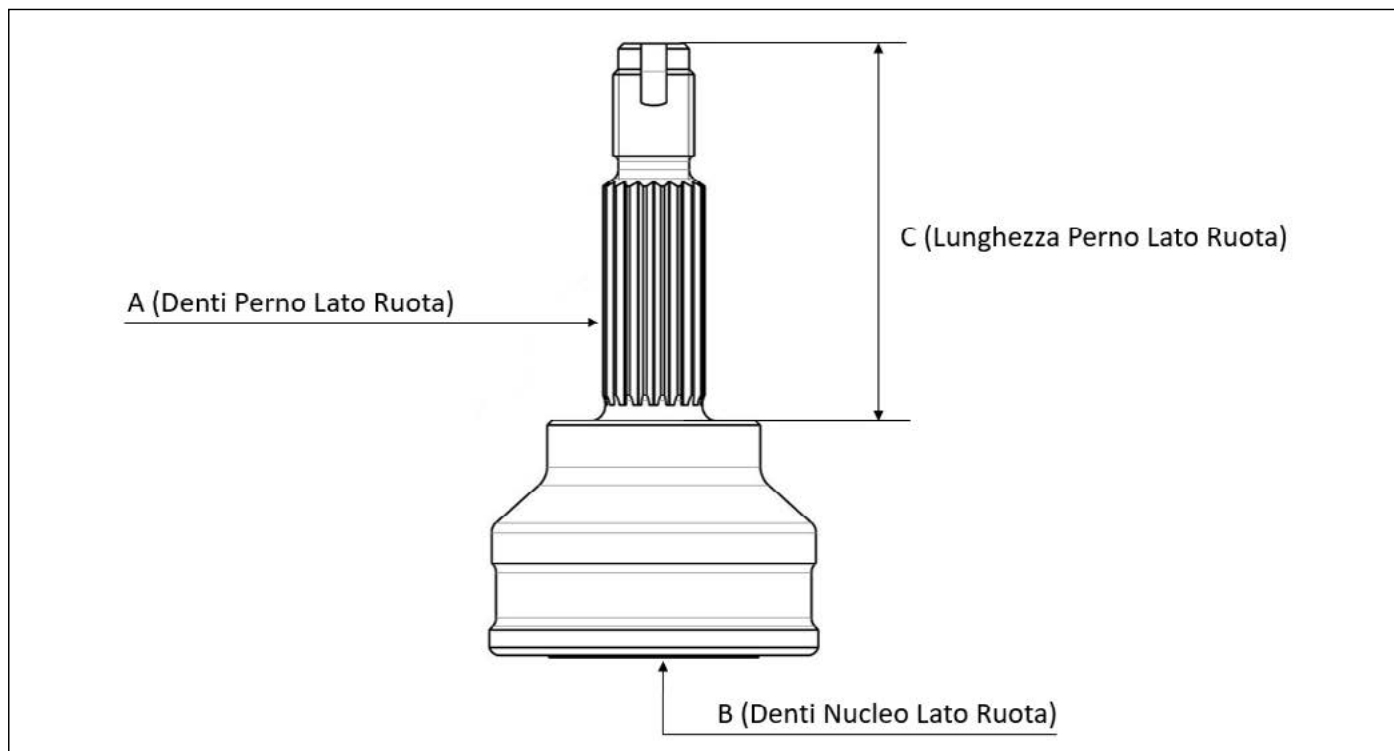

CODICE	APPLICABILITÀ	A (Denti Perno Lato Ruota)	B (Denti Nucleo Lato Cambio)	C (Lunghezza Per- no Lato Ruota)	ABS (Ruota Fonica Z.)
HJM1005K	MICROCAR MGO 1 505 13-15, MGO 2 505 13-15, MGO 3 505 15-19	18	18	74	-
HJM1014K	BELLIER B8 440 15-19, DOCKER 480 16-19, B8 523 15-19, JADE 523 16-19	18	18	80,5	-
	CASALINI M20 480 17-19, KERRY 538 15-19, M14 538 08-14, KERRY 635 15-19, M12 PICKUP 635 15-19				
	CHATENET BAROODER 505 08-19, CH26 EVO 505 16-19, CJF 214 505 95-01, MEDIA 505 98-01, STELLA 505 00-04				
	JDM ROXSY 440 08-19, SIMPA 440 02-19, XHEOS 442 08-19, ABACA 505 05-19, ALBIZIA 505 02-07, ABACA 523 05-19, ALBIZIA 523 02-07, ALOES 523 08-19, ROXSY 523 08-19, TITANE 1/2/3 523 99-02				
	LIGIER JS RC 505 08-19, OPTIMAX 505 00-19, PRIMA 505 00-19, X-TOO 505 02-19, X-TOO MAX 505 02-05, X-TOO R 505 00-19				
MICROCAR MGO 4 498 16-19, CARGO 505 07-19, MGO 1 505 08-13, MGO 2 505 08-13, MGO 3 505 15-19, MGO 4 505 16-19					
HJM1015K	AIXAM 300 276 99-05, 400 400 99-05, 500 400 99-05, 500,4 400 99-05, A721 400 05-08, A741 400 05-08, EVOLUTION 400 400 02-19, A751 500 05-08	18	18	74	-
	LIGIER IXO 505 11-19, JS 36 505 14-19, JS 40 505 11-19, JS 48 (P70) 505 09-19, JS 50 F1 505 09-12, JS 50 F2/F3 505 12-19, JS 50 F4 505 19-19, JS 48 ELETTRICA 11-19, JS58 ELETTRICA 15-19				
	MICROCAR MC1 505 03-07, MC2 505 03-07, MC1 523 03-07				
HJM1017K	CASALINI M14 ABS 635 14-19	18	18	80,5	45
HJM1018K	AIXAM CITY ABS 400 10-12, CROSSLINE ABS 400 10-19, GTO ABS 400 10-19, CITY ABS 500 12-19, CROSSLINE ABS 500 10-19	18	18	69	42
HJM1019K	AIXAM CITY 400 10-12, CROSSLINE 400 10-19, GTO 400 10-19, CITY 500 12-19, COUPE 500 12-19, CROSSLINE 500 10-19	18	18	69	-
HJM1020K	CHATENET CH26 EVO 505 16-19	18	18	80,5	-

PASTIGLIE FRENO ANTERIORI



◀ cod. **BPM0001**

Pastiglie freno anteriori

APPLICABILITÀ

LIGIER IXO 505 11-19, JS 36 505 14-19, JS 40 505 11-19, JS RC 505 08-19, OPTIMAX 505 00-19

MICROCAR M8 480 16-19, M8 500 16-19, CARGO 505 07-19, DUÈ FIRST 505 11-19, F8 505 11-19, MGO 2 505 08-13

RIFERIMENTO ORIGINALE

Ligier	1008464
Microcar	1008464



◀ cod. **BPM0003**

Pastiglie freno anteriori

APPLICABILITÀ

CHATENET CH26 505 10-19, CH26 EVO 505 16-19

JDM ROXSY 440 08-19, XHEOS 442 08-19, ROXSY 523 08-19

RIFERIMENTO ORIGINALE

Chatenet	01.17.376
Chatenet	01.17.377

PASTIGLIE FRENO ANTERIORI



◀ cod. **BPM0005**

Pastiglie freno anteriori Piaggio Porter 16V Van - 0449187503000 - 83714

APPLICABILITÀ

PIAGGIO QUARGO 500 DIESEL 05-17, PORTER 1000 4T 92-98, PORTER 1000 PICK-VAN 1000 4T 92-09, PORTER D120 E5 1200 DIESEL 11-15, PORTER DIESEL 1200 1200 DIESEL 95-00, PORTER MAXXI D120 EURO5 1200 4T 4V 11-15, PORETR MULTITECH EURO4 - EURO5 - EURO5+ 1300 4T 4V 10-15, PORETR MULTITECH EURO6 - EURO6-C 1300 4T 4V 15-20, PORETR MULTITECH EURO6 ENTRY LEVEL 1300 4T 4V 17-20, PORETR MULTITECH MAXXI EURO4 - EURO5 1300 4T 4V 10-15, PORETR MULTITECH MAXXI EURO6 1300 4T 4V 15-19, PORTER 1300 PICK-VAN 1300 4T 92-09, PORTER 16V PICK UP-MAXXI-GPL-4X4 1300 4T 4V 98-09, PORTER 16V VAN 1300 4T 4V 98-07, PORTER MAXXI 1300 4T 4V 08-08, PORTER MAXXI UP-DATE 1300 4T 4V 09-10, PORTER UP-DATE 1300 4T 4V 09-10, PORTER DIESEL 1400 1400 DIESEL 95-00, PORTER PICK DIESEL 1400 DIESEL 98-05, PORTER VAN DIESEL 1400 DIESEL 98-05



◀ cod. **BPM0006**

Pastiglie freno anteriori Piaggio M 500 - 838667

APPLICABILITÀ

PIAGGIO M 500 500 DIESEL 03-10

PASTIGLIE FRENO POSTERIORI



◀ cod. **BPM0002**
Pastiglie freno posteriori

APPLICABILITÀ

LIGIER IXO 505 11-19, JS 36 505 14-19, JS 40 505 11-19, JS RC 505 08-19, OPTIMAX 505 00-19

MICROCAR M8 480 16-19, M8 500 16-19, CARGO 505 07-19, DUÈ F1RST 505 11-19, F8 505 11-19, MGO 2 505 08-13

RIFERIMENTO ORIGINALE

Ligier	1008465
Microcar	1008465



◀ cod. **BPM0004**
Pastiglie freno posteriori

APPLICABILITÀ

CHATENET CH26 505 10-19, CH26 EVO 505 16-19

JDM ROXSY 440 08-19, XHEOS 442 08-19, ROXSY 523 08-19

RIFERIMENTO ORIGINALE

Chatenet	01.17.390
Chatenet	01.17.391
Chatenet	01.17.392



◀ cod. **BPM0007**
Pastiglie freno posteriori Piaggio M 500 - 838661

APPLICABILITÀ

PIAGGIO M 500 500 DIESEL 03-10

PINZE FRENO ANTERIORI



◀ cod.
Pinze freno anteriori

APPLICABILITÀ

LIGIER IXO 505 11-19, JS 36 505 14-19, JS 40 505 11-19, JS RC 505 08-19, OPTIMAX 505 00-19
MICROCAR M8 480 16-19, M8 500 16-19, CARGO 505 07-19, DUÈ FIRST 505 11-19, F8 505 11-19, MGO 2 505 08-13

RIFERIMENTO ORIGINALE

Ligier	1008512
Microcar	1008512



◀ cod. **BCM6002**
Pinze freno anteriori

APPLICABILITÀ

LIGIER IXO 505 11-19, JS 36 505 14-19, JS 40 505 11-19, JS RC 505 08-19, OPTIMAX 505 00-19
MICROCAR M8 480 16-19, M8 500 16-19, CARGO 505 07-19, DUÈ FIRST 505 11-19, F8 505 11-19, MGO 2 505 08-13

RIFERIMENTO ORIGINALE

Ligier	1008469
Microcar	1008469



◀ cod. **BCM6009**
Pinze freno anteriori

APPLICABILITÀ

CHATENET CH26 505 10-19, CH26 EVO 505 16-19
JDM ROXSY 440 08-19, XHEOS 442 08-19, ROXSY 523 08-19

RIFERIMENTO ORIGINALE

Chatenet	01.17.449
Chatenet	01.17.318
Chatenet	0203034



◀ cod. **BCM6010**
Pinze freno anteriori

APPLICABILITÀ

CHATENET CH26 505 10-19, CH26 EVO 505 16-19
JDM ROXSY 440 08-19, XHEOS 442 08-19, ROXSY 523 08-19

RIFERIMENTO ORIGINALE

Chatenet	01.17.448
Chatenet	01.17.317

PINZE FRENO POSTERIORI



◀ cod. **BCM6003**

Pinze freno posteriori

APPLICABILITÀ

LIGIER IXO 505 11-19, JS 36 505 14-19, JS 40 505 11-19, JS RC 505 08-19, OPTIMAX 505 00-19

MICROCAR M8 480 16-19, M8 500 16-19, CARGO 505 07-19, DUE FIRST 505 11-19, F8 505 11-19, MGO 2 505 08-13

RIFERIMENTO ORIGINALE

Microcar	1009188
Ligier	1403881



◀ cod. **BCM6004**

Pinze freno posteriori

APPLICABILITÀ

LIGIER IXO 505 11-19, JS 36 505 14-19, JS 40 505 11-19, JS RC 505 08-19, OPTIMAX 505 00-19

MICROCAR M8 480 16-19, M8 500 16-19, CARGO 505 07-19, DUE FIRST 505 11-19, F8 505 11-19, MGO 2 505 08-13

RIFERIMENTO ORIGINALE

Microcar	1009189
Ligier	1403880
Ligier	1408751



◀ cod. **BCM6011**

Pinze freno posteriori

APPLICABILITÀ

CHATENET CH26 505 10-19, CH26 EVO 505 16-19

JDM ROXSY 440 08-19, XHEOS 442 08-19, ROXSY 523 08-19

RIFERIMENTO ORIGINALE

Chatenet	01.17.451
----------	-----------



◀ cod. **BCM6012**

Pinze freno posteriori

APPLICABILITÀ

CHATENET CH26 505 10-19, CH26 EVO 505 16-19

JDM ROXSY 440 08-19, XHEOS 442 08-19, ROXSY 523 08-19

RIFERIMENTO ORIGINALE

Chatenet	01.17.450
----------	-----------

MICROCAR *POMPE ACQUA*



◀ cod. **PAMC001**

Pompa acqua con guarnizioni economy per Lombardini – ED0065844380-S - 1003198 / 1003198



◀ Cod. **PAMC002**

Pompa acqua con guarnizioni per Lombardini – ED0065844380-S - 1003198 / 1003198 - (versione originale)



◀ cod. **PAMC003**

Pompa acqua per Lombardini – ED0065845110-S - LDW492 /422



◀ cod. **PAMC004**
Pompa acqua per Kubota 400cc - K1585273030 - ventolina 9 mm



◀ cod. **PAMC005**
Pompa acqua per Kubota 400cc - K1906973030 - ventolina 12 mm



◀ cod. **PAMC006**
Pompa acqua per Yanmar 2TNE68 - Y1119520 - 1005048

MICROCAR *POMPE GASOLIO*



◀ cod. **PGMC001**
Pompa elettrica gasolio per Lombardini ED0065851110-S - 1409022 / 1409022



◀ cod. **PGMC002**
Pompa elettrica gasolio con elettrostop per Lombardini ED0065851110-S
1409022 / 1409022



◀ cod. **PGMC003**
Pompa gasolio per Kubota Z402 / Z482 - 1582152030

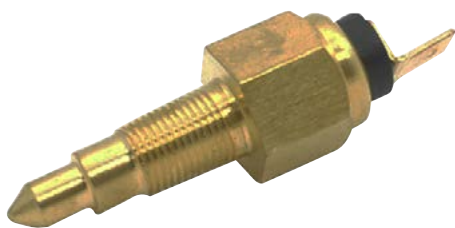

◀ cod. **SEMC001**
Termistore per Kubota - K162228304 - AIXAM



◀ Cod. **SEMC003**
Sensore olio temperatura / pressostato olio per Kubota - K158413901
non originale

ELETTROSTOP



◀ cod. **SEMC002**
Elettrostop per Kubota - Solenoide - K168516001



◀ cod. **SEMC004**
Elettrostop - Solenoide per motore Yanmar - UTMBY32 - Y119653-77950 - 1004992
non originale



◀ cod. **SEMC005**
Elettrostop 2 fili per Mitsubishi - M30L870061

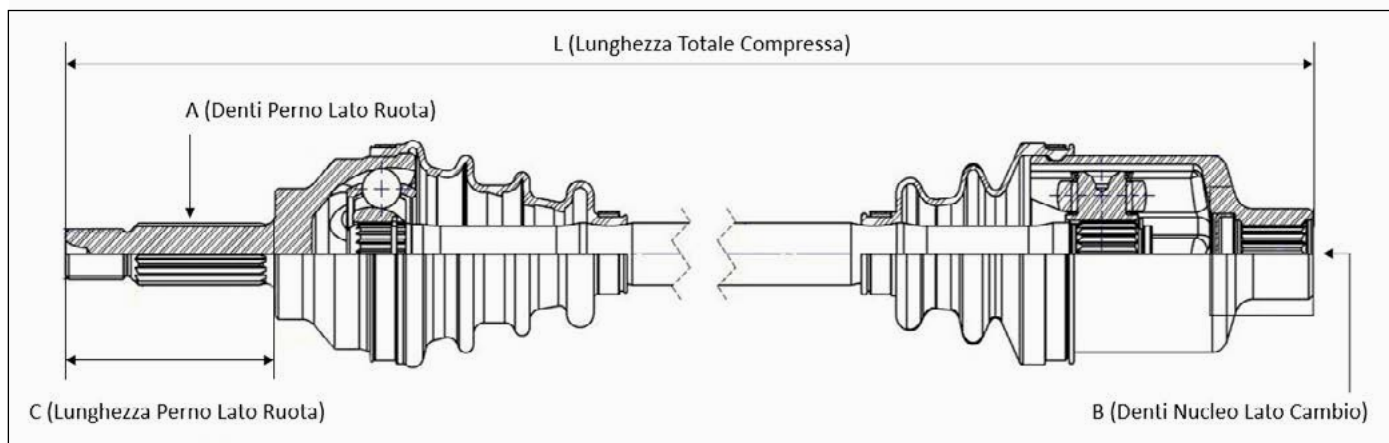

CODICE	MARCA	APPLICABILITÀ	RIFERIMENTO ORIGINALE	A (Denti Perno Lato Ruota)	B (Denti Nucleo Lato Cambio)	C (Lunghezza Perno Lato Ruota)	L (Lunghezza Compresa)	ABS (Ruota Fonica Z.)
DSM03002	BELLIER	B8 440 16-17, B8 523 16-17		18	18	80,5	511,5	-
DSM03003	BELLIER	B8 440 16-17, B8 523 16-17	202800	18	18	80,5	604,5	-
DSM03026	JDM	SIMPA 440 02-19		18	18	80,5	568,5	-
DSM03027	JDM	SIMPA 440 02-19		18	18	80,5	638	-
DSM03048	JDM	ABACA 505 05-19, ALBIZIA 505 02-07, ABACA 523 05-19, ALBIZIA 523 02-07		18	18	80,5	636	-
DSM03066	LIGIER	X-T00 505 05-07	01200005	18	18	80,5	604,5	-
DSM03075	BELLIER	JADE 523 16-19	00202804	18	18	80,5	587,5	-
DSM03086	MICROCAR	MGO 3 505 15-19	1008558	18	18	74	562	-
DSM03091	LIGIER	X-T00 505 07-19	141069	18	18	80,5	658	-
DSM03092	LIGIER	X-T00 505 07-19	141070	18	18	80,5	555	-
DSM03097	MICROCAR	MGO 1 505 13-15, MGO 2 505 13-15	1006226	18	18	74	598	-
DSM03129	LIGIER	JS 50 F1 505 09-10	141074	18	18	74	534	-
DSM03130	LIGIER	JS 50 F1 505 09-10	141073	18	18	74	626	-
DSM03134	CHATENET	CH26 EVO 505 16-19	0126144	18	18	80,5	653	-
DSM03142	LIGIER	JS50F1 10-12	141076 - 1411610/A	18	18	74	565	-
DSM03150	LIGIER	JS 48 (P70) 505 09-19	1401488	18	18	74	613	-
DSM03151	AIXAM	CITY ABS 400 10-12	3AP518A	18	18	69	610,5	42
DSM03153	CASALINI	M14 538 12-14	7857	18	18	80,5	563	-
DSM03154	CASALINI	M14 538 12-14	7858	18	18	80,5	617	-
DSM03156	CASALINI	M14 538 12-14	7856	18	18	80,5	573	-
DSM03157	LIGIER	JS 50 F2/F3 505 12-19	1403279	18	18	74	677,5	-
DSM03158	LIGIER	JS 50 F2/F3 505 12-19	1403278	18	18	74	581	-
DSM03161	AIXAM	CITY 500 12-19, COUPÉ 500 12-19	3AP518	18	18	69	610,5	-
DSM03162	AIXAM	CITY ABS 500 12-19	3MH519A	18	18	69	563	42
DSM03163	AIXAM	CITY ABS 500 12-19	3MH518A	18	18	69	653,5	42
DSM03165	AIXAM	A721 400 05-08, A741 400 05-08, A751 500 05-08						
	LIGIER	IXO 505 11-19		18	18	74	598	-
	MICROCAR	MC1 505 03-07, MC2 505 03-07, MC1 523 03-07	1006226					
DSM03166	AIXAM	400 400 99-05, 500,4 400 99-05, EVOLUTION 400 400 02-19						
	LIGIER	IXO 505 11-19		18	18	74	562	-
	MICROCAR	MC1 505 03-07, MC2 505 03-07, MC1 523 03-07	1008558					
DSM03176	BELLIER	JADE 523 16-19						
	JDM	TITANE 1/2/3 523 99-02		18	18	80,5	598,5	-
	LIGIER	X-T00 505 02-05, X-T00 MAX 505 02-05						



CODICE	MARCA	APPLICABILITÀ	RIFERIMENTO ORIGINALE	A (Denti Perno Lato Ruota)	B (Denti Nucleo Lato Cambio)	C (Lunghezza Perno Lato Ruota)	L (Lunghezza Compresa)	ABS (Ruota Fonica Z.)
DSM03180	CHATENET	BAROODER 505 08-19						
	LIGIER	OPTIMAX 505 00-19, PRIMA 505 00-19, X-T00 R 505 00-19		18	18	80,5	665	-
	MICROCAR	MGO 4 498 16-19, CARGO 505 07-19, MGO 3 505 15-19, MGO 4 505 16-19						
DSM03184	CASALINI	M14 538 08-12	F0040000773					
	CHATENET	BAROODER 505 08-19	0118007					
	JDM	ROXSY 440 08-19, XHEOS 442 08-19, ALOES 523 08-19, ROXSY 523 08-19		18	18	80,5	612	-
	LIGIER	JS RC 505 08-19						
	MICROCAR	MGO 1 505 08-13, MGO 2 505 08-13						
DSM03185	CASALINI	M14 538 08-12	F0040000774	18	18	80,5	653	-
DSM03219	LIGIER	JS 48 ELETTRICA 11-19	1400468	18	18	74	657	-
DSM03220	LIGIER	JS 40 505 11-19	1401231	18	18	74	651,5	-
DSM03233	LIGIER	JS 48 ELETTRICA 11-19	1400469	18	18	74	521	-
DSM03234	LIGIER	JS 40 505 11-19	1401230	18	18	74	548,5	-
DSM03235	CASALINI	KERRY 538 15-19, KERRY 635 15-19, M12 PICKUP 635 15-19						
	CHATENET	CJF 214 505 95-01, MEDIA 505 98-01, STELLA 505 00-04		18	18	80,5	579,5	-
	JDM	ABACA 505 05-19, ALBIZIA 505 02-07, ABACA 523 05-19, ALBIZIA 523 02-07						
DSM03236	CASALINI	KERRY 538 15-19, KERRY 635 15-19, M12 PICKUP 635 15-19	F0040000708 F0040000788 F0040000610	18	18	80,5	619,5	-
DSM03263	LIGIER	JS 36 505 14-19	1405360 - 3AA018	18	18	74	592	-
DSM03264	AIXAM	400 400 99-05	3G018	18	18	74	556,5	-
DSM03265	AIXAM	300 276 99-05, 400 400 99-05, 500 400 99-05	3L018	18	18	74	586	-
DSM03266	AIXAM	400 400 99-05	3MB018	18	18	74	610,5	-
DSM03268	CASALINI	M14 ABS 635 14-19	F0040000773A	18	18	80,5	612	45
DSM03269	CASALINI	M14 ABS 635 14-19	F0040000774A	18	18	80,5	658	45
DSM03271	CHATENET	CH26 EVO 505 16-19	01110095	18	18	80,5	604,5	-
DSM03272	LIGIER	JS 50 F1 505 10-12	1411609-A	18	18	74	665	-
DSM03275	CASALINI	M20 480 17-19	F0040000802	18	18	80,5	592,5	-
DSM03276	CASALINI	M20 480 17-19	F0040000801	18	18	80,5	637	-
DSM03279	BELLIER	DOCKER 480 16-19	00202826	18	18	80,5	511,5	-
DSM03280	BELLIER	B8 440 17-19, B8 523 17-19	00202825	18	18	80,5	569	-
DSM03292	LIGIER	JS58 ELETTRICA 15-19	1414957	18	18	74	667	-
DSM03293	LIGIER	JS58 ELETTRICA 15-19	1414958	18	18	74	567,5	-
DSM03295	BELLIER	B8 440 15-16, B8 523 15-16		18	18	80,5	640,5	-
DSM03296	LIGIER	JS 50 F4 505 19-19	1416343	18	18	74	621,5	-
DSM03298	AIXAM	CITY 400 10-12, CROSSLINE 400 10-19, GTO 400 10-19, CROSSLINE 500 10-19	3AP518	18	18	69	610,5	-



◀ cod. **TSMC001**
Testa di Sterzo Piaggio Porter 16V Van - 4504787Z02000

APPLICABILITÀ

PIAGGIO PORTER 1000 4T 92-98, PORTER 1000 PICK-VAN 1000 4T 92-09, PORTER DIESEL 1200 1200 DIESEL 95-00, PORTER 1300 PICK-VAN 1300 4T 92-09, PORTER 16V PICK UP-MAXXI-GPL-4X4 1300 4T 4V 98-09, PORTER 16V VAN 1300 4T 4V 98-07, PORTER MAXXI UP-DATE 1300 4T 4V 09-10, PORTER UP-DATE 1300 4T 4V 09-10, PORTER DIESEL 1400 1400 DIESEL 95-00



◀ cod. **TSMC001**
Testa di Sterzo Piaggio Porter 16V Van - 4504687Z02000

APPLICABILITÀ

PIAGGIO PORTER 1000 4T 92-98, PORTER 1000 PICK-VAN 1000 4T 92-09, PORTER DIESEL 1200 1200 DIESEL 95-00, PORTER 1300 PICK-VAN 1300 4T 92-09, PORTER 16V PICK UP-MAXXI-GPL-4X4 1300 4T 4V 98-09, PORTER 16V VAN 1300 4T 4V 98-07, PORTER MAXXI UP-DATE 1300 4T 4V 09-10, PORTER UP-DATE 1300 4T 4V 09-10, PORTER DIESEL 1400 1400 DIESEL 95-00



A series of horizontal dotted lines for writing notes, starting from the top of the page and extending down to the bottom.



A series of horizontal dotted lines spanning the width of the page, intended for writing notes. The lines are evenly spaced and extend from the left margin to the right margin.

A series of 12 horizontal dotted lines for writing notes.



A series of horizontal dotted lines spanning the width of the page, intended for writing notes. The lines are evenly spaced and extend from the left margin to the right margin.





motorparts.it

Seguici su  



Motorparts S.r.l.
Motorparts a LKQ company
Via Aldina, 26
40012 Lippo di Calderara di Reno (BO)
Tel. +39 051 725442 - fax +39 051 725449
info@motor-parts.it